

Document downloaded from:

<http://hdl.handle.net/10251/116746>

This paper must be cited as:

Catalá-Icardo, M.; Torres-Cartas, S.; Meseguer-Lloret, S.; Simó-Alfonso, E.; Herrero Martínez, J. (2018). Photografted fluoropolymers as novel chromatographic supports for polymeric monolithic stationary phases. *Talanta*. 187:216-222.  
doi:10.1016/j.talanta.2018.05.026



The final publication is available at

<http://doi.org/10.1016/j.talanta.2018.05.026>

Copyright Elsevier

Additional Information

**Photografted fluoropolymers as novel chromatographic supports for polymeric  
monolithic stationary phases**

M. Catalá-Icardo<sup>1</sup>, S. Torres-Cartas<sup>1</sup>, S. Meseguer-Lloret<sup>1</sup>, E.F. Simó-Alfonso<sup>2</sup>,  
J.M. Herrero-Martínez<sup>2</sup>

<sup>1</sup> *Instituto de Investigación para la Gestión Integrada de Zonas Costeras, Campus de Gandía, Universitat Politècnica de València, C/ Paranimf 1, 46730 Grao de Gandía, Valencia, Spain*

<sup>2</sup> *Department of Analytical Chemistry, Universitat de València, Dr. Moliner 50, 46100 Burjassot, Valencia, Spain*

\*Corresponding authors: Dr. José Manuel Herrero-Martínez  
Tel.: +34963544062  
Fax: +34963544436  
e-mail: [jmherrer@uv.es](mailto:jmherrer@uv.es)

Dr. Mónica Catalá-Icardo  
Tel.: +34 96 284 93 33  
Fax: +34 96 284 93 09  
e-mail: [mocaic@qim.upv.es](mailto:mocaic@qim.upv.es)

## **Abstract**

In this study, porous polymer monoliths were *in situ* synthesized in fluoropolymers tubing to prepare microbore HPLC columns. To ensure the formation of robust homogeneous polymer monoliths in these housing supports, the inner surface of fluoropolymer tubing was modified in a two-step photografting process. Raman spectroscopy and scanning electron microscopy (SEM) confirmed the successful modification of the inner ethylene-tetrafluoroethylene (ETFE) wall and the subsequent attachment of a monolith onto the wall. Poly(glycidyl methacrylate-co-divinylbenzene), poly(butyl methacrylate-co-ethyleneglycol dimethacrylate) and poly(styrene-co-divinylbenzene) monoliths were *in situ* synthesized by thermal polymerization within the confines of surface vinylized ETFE tubes. The resulting monoliths exhibited good permeability and mechanical stability (pressure resistance up to 9 MPa). The chromatographic performance of these different monolithic columns was evaluated via the separation of alkyl benzenes and proteins in a conventional HPLC system.

**Keywords:** Photografting; fluoropolymer; ethylene-tetrafluoroethylene; monolithic column; reversed-phase liquid chromatography

## **1. Introduction**

Porous polymer-based monoliths have attracted substantial interest in the last years and have been satisfactorily applied as chromatographic supports in the field of bio-separation [1-2]. It is worth noting that most of these works reported until now have used fused-silica capillaries (75-200  $\mu\text{m}$ ) as common supports for the preparation of these monolithic columns due to the simplicity of the covalent bonding of the monolith onto the modified inner wall via previous vinylization of the silica surface. However, capillaries are hardly adaptable to conventional HPLC systems, since they require working at very low flow rates, small injection volumes, minimal extra-column and detector cell volumes, which increased the cost of the analytical instrumentation (capillary/nano-LC).

In the last years, few efforts have been made to fabricate microbore monolithic columns (0.5-1.0 mm i.d.) using different housing materials such as glass [3], silicosteel [4], titanium [5], polyether ether ketone (PEEK) [6-7], or polypropylene (PP) tubing [8]. Although these approaches have obtained varying degrees of success, the columns may

suffer from the shrinkage of the monolith due to the upscaling process. For instance, the monolith shrinkage during polymerization, albeit negligible in capillaries, it is strong enough to breakdown the monolith-tube anchorage when larger diameter tubes are employed. In this sense, certain strategies have been proposed, such as the use of an external mold together with a proper selection of monomers providing a highly flexible polymer [9], a titanium scaffold [10], solvents that keep the stationary phase in the swollen-state [11], and polymerization under high pressures [12].

Fluoropolymers represent a rather specialized group of polymeric materials with large number of new types being continuously developed. Some are derivatives of the original polytetrafluoroethylene (PTFE), such as fluorinated ethylene propylene, perfluoroalkoxy and ethylene-tetrafluoroethylene (ETFE) [13]. These materials are known to have excellent chemical resistance, good mechanical properties, high thermal stability, low dielectric constant and transparency to UV radiation [13]. These compounds have been used in numerous industrial applications, such as in aerospace, automotive, petrochemicals, medical, microelectronics and electrical industries. Also, they have been used as suitable materials in analytical field including sample preparation and optical devices, automation methods, trace metal analysis, etc. Their favorable properties, together with the fact that they can be easily and cheaply purchased in different formats and sizes, make fluoropolymers a good choice as housing material in the preparation of monolithic polymer columns, either with preparative or analytical purposes. However, the hydrophobicity and low reactivity of fluoropolymers have hindered the onset of stationary phases covalently attach to fluoropolymer surfaces until very recently.

Surface modification of fluoropolymers has been reported by means of several wet chemical treatments [9,14-16], as well as by some physical procedures such as plasma [17], ion beam [18],  $\gamma$ -radiation [19], extreme UV light [20] or vacuum UV light [21]. However, the physical treatments cannot be easily used to modify the inner surface of narrow tubes, since they are not routinely available in most laboratories, and moreover they can produce the degradation of the fluoropolymers [16]. Among the chemical treatments, the use of etchant reagents such as sodium naphthalene solution (Fluoroetch<sup>®</sup>) [22-23], peroxide/sulfuric acid [24] or permanganate/nitric acid mixtures [25] have been proposed to introduce polar groups such as hydroxyls or carboxylates onto fluoropolymer surfaces.

Recently, we have described the preparation of methacrylate-based monoliths in PTFE tubing using a surface modification method similar to those described in ref. [9,

24-23]; however environmental and safety concerns as well as the difficulties in controlling the depth profiles of the treatments make these methods unsuitable from a green and sustainable perspective.

An alternative strategy for polymer surface modification and functionalization involves the use of UV photografting technology, which represents simple and clean technique [26]. In addition, this technology is characterized by low electrical power input and energy requirements, low temperature operation and no volatile compounds release. It has been used to modify the surface of different polymers (polyolefins, polyesters, polyamides and polyethers) [27-28] and, particularly, polypropylene (PP) in several formats, such as pipette tip [29-30] or tubes [8,31] for anchoring polymer monoliths. This process is based on the capacity of UV light to abstract hydrogen atoms. Firstly, radicals are formed onto the polymeric surface through a photo-reduction reaction between a photoinitiator (commonly benzophenone) and the C-H bonds. Then, the new generated radical initiates the polymerization of the monomers (added together with the photoinitiator or in a following step), resulting in graft polymer chains chemically bonded onto the substrates [27]. Due to the higher difficulty that defluorination entails, BP in combination with strong reducing agents (*e.g.* sodium hydride) has been described for surface modification of PTFE or other fluoropolymers [23]. Also, other photosensitizers such as xanthone have been described for the surface modification of PTFE or ETFE materials [16].

The goal of this study was to develop a monolithic column for its use in microbore HPLC using a photografted fluoropolymer tubing as housing material. For this purpose, several fluoropolymer tubes (0.75-0.8 mm i.d.) were treated with a two-step UV photografting process to make possible the anchorage of monolith to fluoropolymer wall. Using ETFE as probe material, the grafting conditions were optimized in order to provide a robust covalent anchorage of the monolith to the fluoropolymer surface. To our knowledge, this modification technique has not been explored yet in fluoropolymer materials to host polymer monoliths as stationary phases. Three different polymers based on glycidyl methacrylate, butyl methacrylate and styrene monomers, were prepared in ETFE tubing using the optimized photografting treatment, and they were applied to the separation of alkylbenzenes and proteins in a conventional HPLC system. As far as we know, this is the first time that photografted ETFE tubes were used as housing material for polymer monoliths and its use in reversed-phase LC separation.

## 2. Materials and methods

### 2.1. Chemicals and reagents

Glycidyl methacrylate (GMA), butyl methacrylate (BMA), ethyleneglycol dimethacrylate (EDMA), tetrahydrofuran (THF), 1,4-butanediol, 1-propanol and trifluoroacetic acid (TFA) were from Sigma-Aldrich (Steinheim, Germany). Styrene (STY), divinylbenzene (DVB) (technical grade, 80% mixture of isomers, 20% mainly ethylstyrene), 1-decanol, 1-dodecanol, benzophenone (BP) and lauroyl peroxide (LPO) were supplied by Alfa Aesar (Karlsruhe, Germany). Azobisisobutyronitrile (AIBN) was from Fluka (Buchs, Switzerland). HPLC-grade acetonitrile (ACN) and methanol (MeOH) were from Merck (Darmstadt, Germany). Uracil, alkyl benzenes from Riedel de Haën (Seelze, Germany) and proteins such as ribonuclease A (bovine heart), cytochrome C (bovine pancreas) from Alfa Aesar, and myoglobin (horse skeletal muscle) from Sigma were used as probes. Acetone was supplied by Panreac (Barcelona, Spain). Ultra-pure water was obtained with a Puranity TU6 water purification system from VWR (Bedford, MA, USA) provided with a 0.2  $\mu\text{m}$  filter. Unless otherwise stated, any other chemicals used were of analytical grade. PTFE tubing of 1/16'' (1.6 mm) o.d.  $\times$  0.8 mm i.d. from Omnifit (Fisher Scientific, Loughborough, UK), fluorinated ethylene propylene (FEP), perfluoroalkoxy (PFA) and ETFE tubing of 1/16'' (1.6 mm) o.d.  $\times$  0.75 mm i.d. from Vici Jour (Schenkon, Switzerland) were also used. ETFE tubing of 1/8'' (3.2 mm) o.d.  $\times$  1.57 mm i.d. from IDEX Health & Science LLC (Washington, USA). The chemical structures of the fluoropolymers investigated are given in Fig. 1.

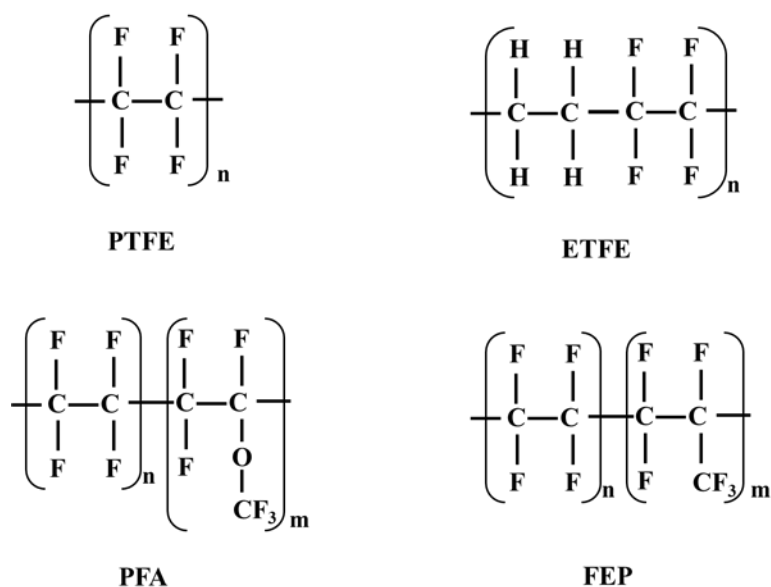

**Fig. 1.** Structures of fluoropolymers investigated in this study.

Stock solutions of alkyl benzenes were prepared in ACN at 1.0 mg mL<sup>-1</sup> each and kept at 4°C until their use. Working standard solutions were freshly prepared by dilution to the desired concentration with the mobile phase. Proteins were dissolved in water at concentration of 1.0 mg mL<sup>-1</sup> each and kept at -18°C.

## 2.2. Instrumentation

An UV crosslinker (model CL1000) from UVP (Upland, CA, USA) equipped with UV lamps (5 x 8W, 254 nm) was used for photografting of fluoropolymer tubings. A syringe pump (Model 100, KD Scientific, New Hope, PA, USA) was employed to introduce the reagents into the supports. SEM photographs of fluoropolymer surfaces and monolithic materials were performed with a scanning electron microscope (S-4800, Hitachi, Ibaraki, Japan) provided with a field emission gun, and an EMIP 3.0 image data acquisition system. Previous to the SEM measurements, the polymeric sorbents were sputter-coated with Au/Pd for 2 min to avoid charging problems. Raman spectra of fluoropolymer surfaces were recorded with an XploRA One Raman microscope (Horiba Scientific, Villeneuve d'Ascq, France) from 150 to 3500 cm<sup>-1</sup> using 532 nm as excitation wavelength with a laser power of 90 μW.

Chromatographic analysis was carried out in an HPLC equipment from Jasco Analytica (Madrid, Spain), composed of a PU-2089 quaternary gradient pump, an AS-2055 autosampler with a 100 μL injection loop and MD-2018 photodiode array detector. The system was controlled using the LC-NETII/AFC interface also supplied by Jasco. Acquisition and data treatment was performed using the ChromNAV software (version 1.17.01).

## 2.3. Photografting of inner wall surface of ETFE tubing

To modify the inner wall surface of fluoropolymer tubing, a two-step procedure was adapted from literature [28,31-32]. Each tube (15-17 cm long) was firstly washed with ethanol and acetone, and dried with nitrogen. Then, the ETFE tube was filled with a deoxygenated solution of 5 wt% of BP in methanol, sealed its ends with caps and irradiated in a UV chamber for 20 min at 0.9 J cm<sup>-2</sup>. The distance between the lamps and tube was set at 2.5 cm. Next, the BP-modified tube (see Fig. 2, step 1) was washed with methanol and subsequently, dried with nitrogen. Afterwards, the BP-modified tube was flushed with a deoxygenated solution of 15 wt% of EDMA in methanol and irradiated

with UV light under the same conditions as above. After UV grafting (see Fig. 2, step2), the washing and drying steps were again carried out.

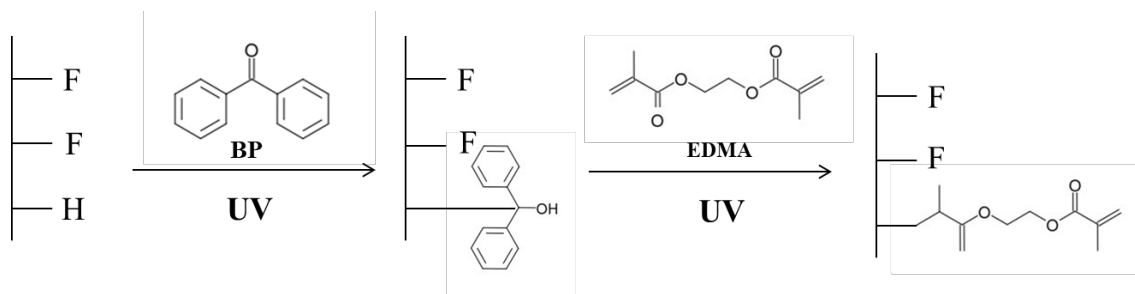

**Fig. 2.** Two-step photografting scheme for chemical modification of ETFE tubing.

#### 2.4. Preparation of polymer monoliths

The EDMA-modified ETFE tubing was filled with polymerization mixture. Three reaction mixtures with different composition (see Table 1 and refs. [6, 9, 32]) were prepared. Each vial with polymerization mixture was sonicated for 3 min to obtain a clear solution, followed by purging with nitrogen for 10 more min. In order to avoid the shrinking and the breaking of the monolith-tube anchorage, the whole tube was submerged into an external polypropylene mold, which has been previously reported [9]. The mold with the tube inside was then vertically placed in an oven for polymerization. The system was heated at the suitable temperature and time (see Table 1). After polymerization, the column was removed from the oven and allowed to cool to room temperature. A 10 cm long column was cut from the tubing, and then the column was fitted with end fittings, connected to an HPLC pump and flushed for 40 min with methanol to remove the pore-forming solvents and possible unreacted monomers.

**Table 1** Composition of polymerization mixtures (wt.%), experimental conditions tested for the polymerization and permeability of the resulting columns

Polymer	Functional monomer	Crosslinker	Porogenic solvents	Temperature/time	Permeability ( $K_0$ ) <sup>a</sup> /10 <sup>-14</sup> m <sup>2</sup>	Reference
STY-co-DVB <sup>b</sup>	24% STY	16% DVB	42% 1-dodecanol 18% toluene	70°C/ 180 min	11.3	[6]
BMA-co-EDMA <sup>b</sup>	24% BMA	16% EDMA	26% 1,4-butanediol 29% 1-propanol 5% water	60°C/ 90 min	3.2	[32]
GMA-co-DVB <sup>c</sup>	10% GMA	23.3% DVB	60.7% 1-decanol 6% THF	70°C/ 240 min	24.9	[9]

<sup>a</sup> Evaluated as  $K_0 = \frac{L\eta\mu_s}{\Delta P}$ , where L is the length of the column,  $\eta$  is the viscosity of the mobile phase (40:60, v/v ACN:H<sub>2</sub>O),  $\mu_s$  is the linear flow velocity, and  $\Delta P$  is the backpressure of the column.

<sup>b</sup> AIBN as initiator (1wt% with respect to the monomers)

<sup>c</sup> LPO as initiator (3wt% with respect to the monomers)



### 3. Results and discussion

#### 3.1. Modification of fluoropolymer inner wall surface and characterization

As we already mentioned in Introduction, (photo)graft hydrophilic monomers directly onto chemically stable fluoropolymers is a challenge. Indeed, the PTFE polymer or other derivatives such as FEP or PFA are materials in whose no hydrogen abstraction can apparently be induced from its structure (see Fig. 1); however, several studies have reported the surface defluorination of PTFE films under UV irradiation [14-15]. For instance, Noh *et al.* [15] have described the use of BP as photoinitiator in combination with sodium hydride in dry dimethylformamide to achieve defluorination, oxygen incorporation and surface insaturation in PTFE surfaces. The surface modification occurs by photoexcitation of either the diphenyl ketyl radical anion intermediate or its final reaction product benzhydrol anion [15]. These photografting studies used higher grafting temperatures ( $>40^{\circ}\text{C}$ ) and, more importantly, high power UV lamps ( $>100\text{ W}$ ), which can lead to a degradation of fluoropolymers. In this sense, the use of ETFE, a partial fluorinated polymer, as substrate could alleviate these grafting conditions due to the presence of abstractable H-atoms in its backbone. Thus, this fluoropolymer was selected as probe material to conduct photografting studies using relatively mild and sustainable conditions, absence of reducing agents, use of low-power UV lamps and room temperature.

To modify this material, a sequential two-step UV photografting process for surface modification of PP materials [8,27,29] was adopted. Figure 2 shows the preparation scheme of the ETFE tubing. In the first step, BP abstracts hydrogen from the polymer surface to generate a surface free radical and semipinacol radicals, which combine to form surface photoinitiators. In the second step, a solution of EDMA (monomer) was photografted to generate vinyl functionalities to assure the posterior binding of monolith to the ETFE inner wall. The contents of BP and EDMA used for the first and second step, respectively, were taken from literature [8, 29] (see Section 2.3), whereas other factors (distance of application of the source of UV light and irradiation time) that influence on the (photo)grafting yield of polymer surfaces were examined. Thus, UV intensity was modified by varying the distance from the UV lamp to the sample by keeping constant the lamp power and time ( $0.9\text{ J cm}^{-2}$  for 15 min) in both grafting steps.

When the irradiation distance was fixed at 13 cm, any change in the physical appearance of the transparent ETFE tubing was evidenced. However, for the irradiation distance of 2.5 cm, a visible white layer was observed on the inner surface of ETFE. SEM micrographs of these tubes corroborated the presence of this layer onto the inner surface (data not shown). This white layer corresponds to a grafted clusters of EDMA, which were anchored to the inner surface of the ETFE tubing [8]. The behavior observed over irradiation distance could be explained by the higher UV power intensity when shorter distance is applied, which tends to promote the grafting process (BP and EDMA), and consequently its bonding to the ETFE wall. Based on these results, the photografting process was conducted at 2.5 cm distance for further studies.

Then, the optimization range of irradiation time (in both photografting steps, up to 25 min) was considered. To monitor the influence of this variable on the surface modification, Raman measurements were done. For this purpose, for each step, after the surface treatment and subsequent washing/drying at room temperature with nitrogen, the ETFE tubing was properly cut into 2 cm long pieces and longitudinally cut open, and its inner surface (directly exposed to the BP/EDMA solutions) was examined using Raman spectroscopy.

Thus, Raman spectra of pristine ETFE material exhibited three intense bands located at 836, 1442 and 2968  $\text{cm}^{-1}$ , which were attributed to  $\text{CF}_2$ ,  $\text{CH}_2$  scissoring and  $\text{CH}_2$  stretching vibrations, respectively [33-34] (see Fig. S1). Figure 3 shows comparative plots of the Raman spectra for several ETFE surfaces subjected to different irradiation times to BP and EDMA photografting. As shown in Fig. 3A, after the treatment with BP, a new band at 1590  $\text{cm}^{-1}$ , attributed to aromatic C=C stretch vibration (corresponding to the immobilized BP radical) was observed. This band increased in intensity as irradiation time increased; however, no significant differences were observed at exposure times above 20 min. Therefore, this time was selected for further experiments. Fig. 3B shows the Raman spectra collected for BP-modified ETFE after grafting EDMA at several irradiation times. As it can be seen, treated samples show the presence of peaks at 1723  $\text{cm}^{-1}$  and 1635  $\text{cm}^{-1}$ , which were assigned to C=O stretching and C=C stretching vibrations, respectively [35-37], due to the grafted EDMA chains. As observed, these new bands progressively increased in intensity as irradiation time until 20 min, and then remained almost constant, selecting this irradiation time for the studies that followed.

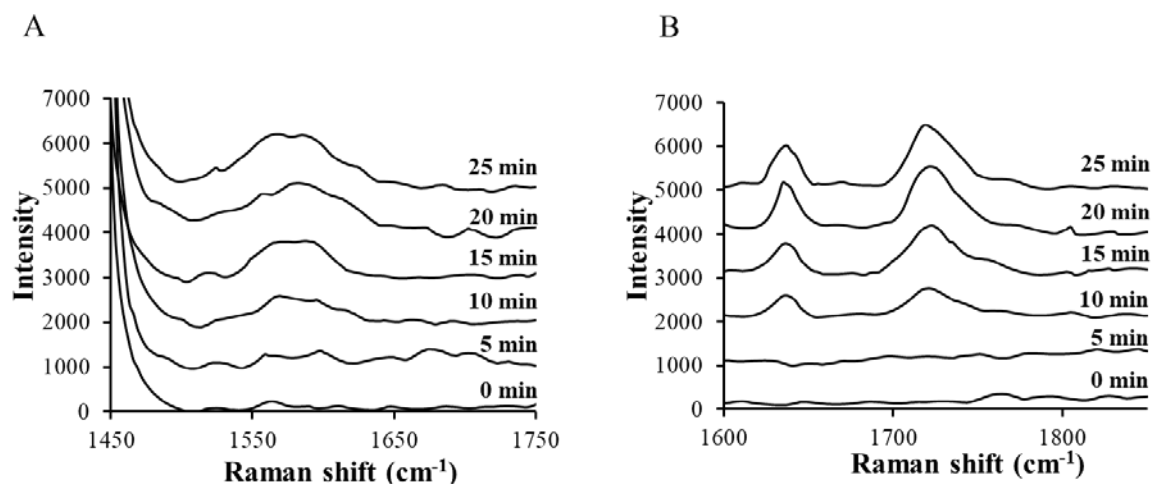

**Fig. 3.** Raman spectra of the inner ETFE tubing treated with: (A) BP and (B) EDMA at several UV irradiation times. The grafting EDMA experiments were conducted using each time as starting material a 20 min BP-treated ETFE material.

The changes of ETFE surfaces treated with UV photografting process were also confirmed by SEM (Fig. 4). Thus, the BP treatment (first step) did not modify the physical appearance of the transparent ETFE tubing, whereas the EDMA grafting (second step) gave an observable white layer bonded to the inner surface.

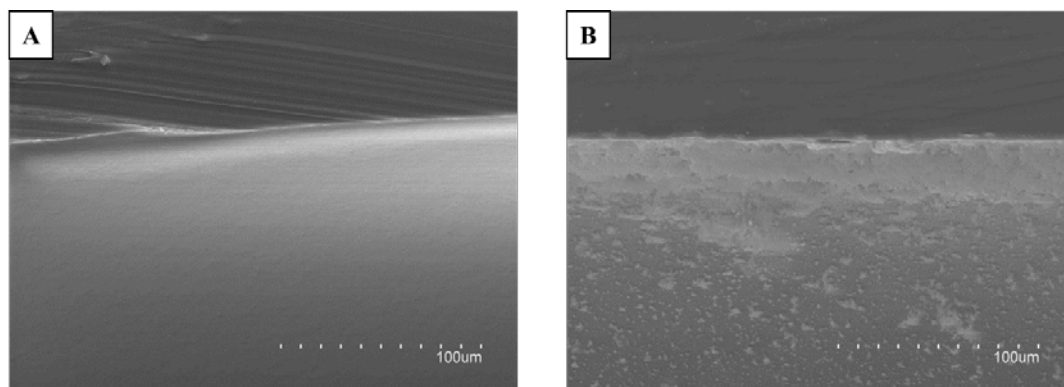

**Fig. 4.** Photographs and SEM micrographs of ETFE tubing untreated (A) and grafted with EDMA layer (B).

To further explore the effectiveness of this photografting process, other fluoropolymers (PTFE, FEP and PFA) were surface-modified using the treatment developed for the ETFE tubing. However, the modified materials did not show the “grafted” characteristic peaks found in Raman spectra neither the presence of EDMA layer in SEM micrographs. This can be ascribed to the fact that the fluorine abstraction in these fluoropolymers is difficult for the excited photosensitizer (BP) to extract, in

contrast to the easy abstraction of hydrogen in the ETFE material. Several authors [16,38] have reported that long irradiation times and high temperatures can increase the extent of the modification. In order to promote the abstraction, longer irradiation times (up to 15 h) were tried; although, similar results were found. At sight of these findings, ETFE was selected as housing support to prepare polymer monoliths.

Prior to evaluate the chromatographic performance of different polymer monoliths (see Table 1) as stationary phases inside 0.75 mm ETFE tubing, the successful covalent attachment of these monoliths onto the fluoropolymer tubing wall was demonstrated. Fig. S2 shows a SEM micrograph of cross-section of a polymeric material (*e.g.* GMA-co-DVB monolith) within the EDMA-grafted tubing. Clearly, the monolith was tightly attached to the tubing surface. The effective anchoring of polymeric monoliths onto the ETFE surface was also confirmed by evaluating the mechanical stability of the resulting monoliths. In this sense, the relationship between flow rate and backpressure drop of the monolith can be used to evaluate its adhesion to the wall. For the three polymer monoliths investigated, good linear relationships ( $r > 0.9994$ ) between backpressure (up to 9 MPa) and flow rate were obtained.

Additionally, to investigate the feasibility of immobilizing polymeric monoliths in wider ETFE tubing, a 1.57 mm i.d. of this material was surface-photografted using a similar surface treatment process. A homogenous monolith (*e.g.* a poly(GMA-co-DVB)) was successfully formed within the tube, without gaps between the inner wall of tube and the monolith (see Fig. S3).

### *3.2. Preparation and characterization of polymer monolithic columns in ETFE supports*

Then, three different monolithic columns thermally initiated (see Table 1 for details) were prepared within ETFE tubing. These columns were morphologically characterized (Fig. 5). The SEM micrographs of the cross-sections of the different polymeric beds revealed the typical interconnected microglobular structure of organic monoliths. As it can be seen, the sizes of globules and flow-through pores of poly(BMA-EDMA) monoliths (Fig. 5B) were smaller than those of the STY- and GMA-based polymers (Fig. 5A and C, respectively), leading to lower permeability values (see Table 1).

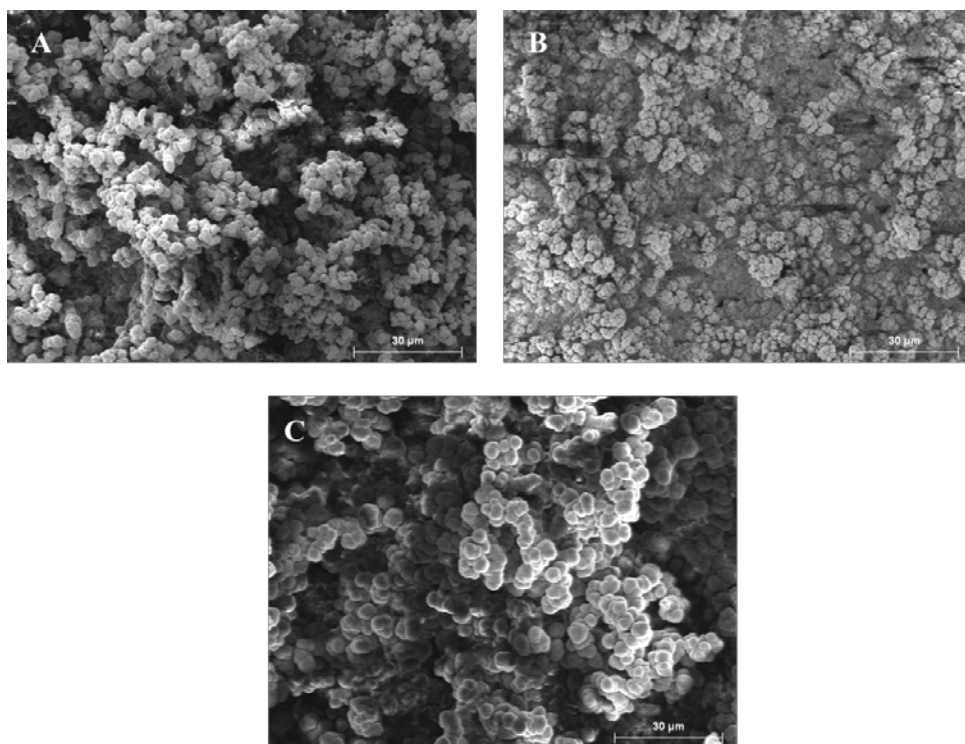

**Fig. 5.** SEM micrographs of cross sections of polymeric monoliths synthesized in modified(grafted)-ETFE tubing: (A) poly(STY-*co*-DVB), (B) poly(BMA-*co*-EDMA) and (C) poly(GMA-*co*-DVB).

Next, the performance of all three monolithic columns was evaluated via the isocratic separation of alkylbenzenes as probe solutes. Thus, the poly(GMA-*co*-DVB) column provided an acceptable separation of these analytes (Fig. 6C) with plate heights between 52 and 74  $\mu\text{m}$  at linear flow rate of  $0.0027 \text{ mm s}^{-1}$  ( $0.3 \text{ mL min}^{-1}$ ). Under these conditions, the poly(STY-*co*-DVB) (Fig. 6A) and poly(BMA-*co*-EDMA) (Fig. 6B) monoliths exhibited plate heights ranged from 61-96 and 64-100  $\mu\text{m}$ , respectively. The lower efficiency of these two latter monoliths may be a consequence of their reduced permeability compared with other columns studied in the present work as deduced from SEM images (see Fig. 5). These plate heights were satisfactory or even better compared to those reported in literature for polymeric monolithic columns made in several housing supports. Thus, the efficiencies found were slightly better than those obtained in our previous study (70-80  $\mu\text{m}$ ) using PTFE tubing [9]. In addition, our plate height values were slower than 100-125  $\mu\text{m}$  reported by Shu *et al.* [7] obtained with poly(LMA-*co*-EDMA) monoliths in PEEK tubing using similar column dimensions (10 cm x 1.0 mm i.d.). Our plate heights were also comparable to poly(STY-*co*-DVB) monolithic columns prepared in this PEEK material (32-38  $\mu\text{m}$ ) [6] or in fused-silica line stainless-steel tubes (30-60  $\mu\text{m}$ ) [32].

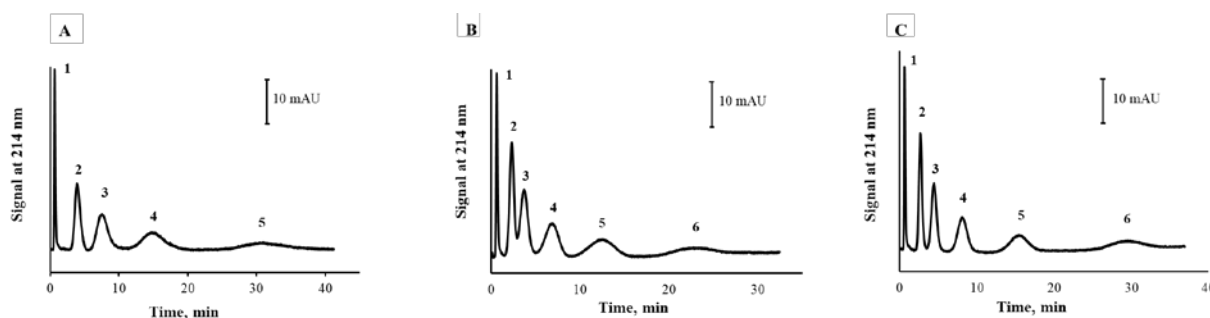
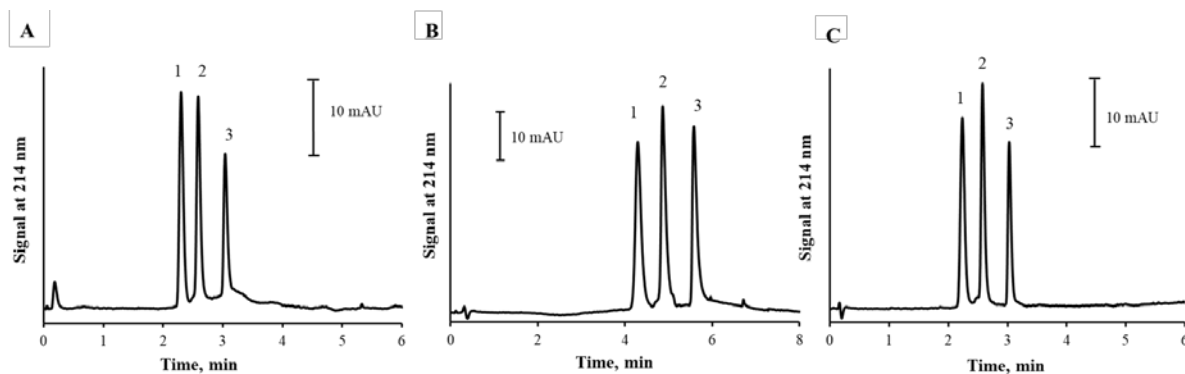

**Fig. 6.** Separation of alkyl benzenes on several polymer monoliths in an ETFE tubing: (A) poly(STY-co-DVB), (B) poly(BMA-co-EDMA) and (C) poly(GMA-co-DVB). Experimental conditions: 100 mm  $\times$  0.75 mm i.d.; mobile phase, 33%(v/v) ACN in water; flow rate, 0.3 mL min<sup>-1</sup>; injection volume, 1  $\mu$ L; UV at 214 nm. Peak identification: (1) uracil, (2) toluene, (3) ethylbenzene, (4) propylbenzene, (5) butylbenzene, (6) pentylbenzene.

The mixture of alkylbenzenes was also separated under gradient elution (Fig. S4). The performance of each column was measured in terms of peak widths at half peak height. The best values (21.0 s) were found for the poly(GMA-co-DVB) column, followed by poly(BMA-co-EDMA) and poly(STY-co-DVB) monoliths (23.4 and 25.2 s, respectively).

The polymeric monolithic columns in ETFE tubing were also applied to the separation of a mixture of three proteins (Fig. 7). Under gradient elution conditions, the STY-co-DVB and GMA-co-DVB columns showed better separation performance (peak width at half peak height values of *ca.* 4.0 s) than that obtained with BMA-co-EDMA column (6.8 s). The higher performance of both monoliths can be attributed to an optimal combination of its porosity and surface chemistry.

Additionally, these polymer monoliths were synthesized in 1.57 mm i.d. ETFE tubing and tested as chromatographic supports. As shown in Fig. S5, satisfactory separations both for small molecules and proteins in RP mode were achieved.



**Fig. 7.** Separation of proteins on several polymer monoliths in an ETFE tubing: (A) poly(STY-co-DVB), (B) poly(BMA-co-EDMA) and (C) poly(GMA-co-DVB). Experimental conditions: mobile phase, A = 0.1% aqueous TFA, B = 0.1% TFA in ACN; linear gradient from 17 to 100% B in A in 5 min at 1 mL min<sup>-1</sup> (trace A); linear gradient from 17 to 60% B in A in 5 min at 0.5 mL min<sup>-1</sup> (trace B); linear gradient from 17 to 100% B in A in 5 min at 1 mL min<sup>-1</sup> (trace C); other experimental conditions as in Fig. 6. Peak identification: (1) ribonuclease A, (2) cytochrome C and (3) myoglobin.

In order to test the reproducibility of the preparation process of polymeric monoliths in ETFE tubing, several chromatographic parameters were evaluated by injecting the alkylbenzene test mixture under conditions given in Fig. 6. Table 2 shows satisfactory run-to-run and day-to-day reproducibilities for all parameters investigated, with RSD values below 4.4%. Also, the column-to-column reproducibility, calculated with three columns in ETFE supports (previously treated with the optimal photografted protocol), gave acceptable RSD values (< 10.8%).

**Table 2.** Repeatability and reproducibility of several chromatographic properties (expressed as RSD%) for the three polymeric monoliths synthesized in ETFE tubing<sup>a</sup>.

Polymeric monolith	Parameter	Repeatability		Reproducibility
		Run-to-run column (n = 3)	Day-to-day column (n = 5, 3 days)	Column-to- column (n = 3)
poly(STY-co-DVB)	t <sub>0</sub> (min)	0.1	0.1	1.3
	k <sub>butylbenzene</sub>	0.4	0.5	2.4
	H <sub>butylbenzene</sub> (μm)	3.2	4.4	4.9
poly(BMA-co-EDMA)	t <sub>0</sub> (min)	0.2	0.1	0.3
	k <sub>butylbenzene</sub>	0.4	0.6	2.3
	H <sub>butylbenzene</sub> (μm)	3.7	8.0	9.8
poly(GMA-co-DVB)	t <sub>0</sub> (min)	0.4	0.2	1.5
	k <sub>butylbenzene</sub>	0.3	0.2	1.0
	H <sub>butylbenzene</sub> (μm)	1.1	2.4	10.8

<sup>a</sup>Working LC conditions as in Fig. 6.

#### 4. Conclusions

In this study, a cost-effective, easy and green modification method of the inner wall surface of fluoropolymers tubing (up to 1.57 mm i.d.) to assure a covalent attachment of polymeric monoliths has been developed. For this purpose, several fluoropolymer materials were treated with a two-step UV photografting process taking advantage of its UV transparency. As a result of this study, ETFE tubing was selected since it showed a successful anchorage of monolith to fluoropolymer wall, which was due to the presence of hydrogen in its structure and the challenging fluorine abstraction in the rest of fluoropolymers considered. The optimization of both steps was monitored by Raman measurements of ETFE tubing. In addition, SEM measurements and adhesion tests corroborated the effective binding of polymer monolith to the inner wall. Then, different polymers poly(STY-co-DVB), poly(BMA-co-EDMA) and poly(GMA-co-DVB) were synthesized in ETFE tubing, and they were chromatographically tested using alkylbenzenes and proteins as test solutes in a conventional HPLC system. The resulting monolithic columns showed a satisfactory pressure resistance and acceptable column efficiency and reproducibility. The developed microbore columns could be employed in different analytical methodologies such as purification, preconcentration, separation or other flow-based applications.



## Acknowledgements

This work was supported by project PROMETEO/2016/145 (Conselleria d'Educació, Investigació, Cultura i Esport, Generalitat Valenciana, Spain). The authors also thank Dr. S. Laredo-Ortíz from the Atomic Spectroscopy section of the SCSIE (University of Valencia), for her help in Raman measurements.

## References

- [1] X. Chen, H.D. Tolley, M.L. Lee, Monolithic capillary columns synthesized from a single phosphate-containing dimethacrylate monomer for cation-exchange chromatography of peptides and proteins, *J. Chromatogr. A* 1218 (2011) 4322–4331.
- [2] A.N. Tasfiyati, E.D. Iftitah, S.P. Sakti, A. Sabarudin, Evaluation of glycidyl methacrylate-based monolith functionalized with weak anion exchange moiety inside 0.5 mm i.d. column for liquid chromatographic separation of DNA, *Anal. Chem. Res.* 7 (2016) 9–16.
- [3] K.N. Smirnov, I.A. Dyatchkov, M.V. Telnov, A.V. Pirogov, O.A. Shpigun, Effect of monomer mixture composition on structure and chromatographic properties of poly(divinylbenzene-co-ethylvinylbenzene-co-2-hydroxyethyl methacrylate) monolithic rod columns for separation of small molecules, *J. Chromatogr. A*, 1218 (2011) 5010–5019.
- [4] T. Umemura, Y. Ueki, K. Tsunoda, A. Katakai, M. Tamada, H. Haraguchi, Preparation and characterization of methacrylate-based semi-micro monoliths for high-throughput bioanalysis, *Anal. Bioanal. Chem.* 386 (2006) 566–571.
- [5] E.P. Nesterenko, P.N. Nesterenko, D. Connolly, F. Lacroix, B. Paull, Micro-bore titanium housed polymer monoliths for reversed-phase liquid chromatography of small molecules, *J. Chromatogr. A* 1217 (2010) 2138-2146.
- [6] C. Lv, J. Heiter, T. Haljasorg, I. Leito, Covalent attachment of polymeric monolith to polyether ether ketone (PEEK) tubing, *Anal. Chim. Acta* 932 (2016) 114-123.
- [7] S. Shu, H. Kobayashi, M. Okubo, A. Sabarudin, M. Butsugan, T. Umemura, Chemical anchoring of lauryl methacrylate-based reversed phase monolith to 1/16'' o.d. polyetheretherketone tubing, *J. Chromatogr. A*, 1242 (2012) 59– 66.
- [8] M. Iacono, D. Connolly, A. Heise, Fabrication of a GMA-co-EDMA monolith in a 2.0 mm i.d. polypropylene housing. *Materials*, 9 (2016) 263-273.

- [9] M. Catalá-Icardo, S. Torres-Cartas, S. Meseguer-Lloret, C. Gómez-Benito, E. Carrasco-Correa, E.F. Simó-Alfonso, G. Ramis-Ramos, J.M. Herrero-Martínez, Preparation of organic monolithic columns in polytetrafluoroethylene tubes for reversed-phase liquid chromatography, *Anal. Chim. Acta* 960 (2017) 160-167.
- [10] R.J. Vonk, A. Vaast, S. Eeltink, P.J. Schoenmakers, Titanium-scaffolded organic-monolithic stationary phases for ultra-high-pressure liquid chromatography, *J. Chromatogr. A* 1359 (2014) 162-169.
- [11] R. Edam, S. Eeltink, D.J.D. Vanhoutte, W.T. Kok, P.J. Schoenmakers, Hydrodynamic chromatography of macromolecules using polymer monolithic columns, *J. Chromatogr. A* 1218 (2011) 8638-8645.
- [12] A.I. Cooper, A.B. Holmes, Synthesis of molded monolithic porous polymers using supercritical carbon dioxide as the porogenic solvent, *Adv. Mater.* 11 (1999) 1270-1274.
- [13] J.G. Drobny, *Technology of Fluoropolymers*; CRC Press: Boca Raton, FL, 2009; pp 1-5.
- [14] I. Noh, J.A. Hubbell, Photograft polymerization of acrylate monomers and macromonomers on photochemically reduced PTFE films, *J. Polym. Sci.: Polym. Chem.* 35 (1997) 3467-3482.
- [15] I. Noh, K. Chittur, S.L. Goodman, J.A. Hubbell, Surface modification of poly(tetrafluoroethylene) with benzophenone and sodium hydride by ultraviolet irradiation, *J. Polym. Sci.: Polym. Chem.* 35 (1997) 1499-514.
- [16] M. Asano, J. Chen, Y. Maekawa, T. Sakamura, H. Kubota, M. Yoshida, Novel UV-induced photografting process for preparing poly(tetrafluoroethylene)-based proton-conducting membranes, *J. Polym. Sci.: Polym. Chem.* 45 (2007) 2624-2637.
- [17] N.S. Kasálková, K. Váchová, P. Slepíčka, V. Švorčík, Surface plasma modification and characterization of poly(Ethylene-alt-tetrafluoroethylene), *110* (2016) 279-283.
- [18] M.M. Nasef, H. Saidi, K.Z.M. Dahlan, Electron beam irradiation effects on ethylene-tetrafluoroethylene copolymer films, *Radiat. Phys. Chem.* 68 (2003) 875-883.
- [19] F. Takrori, Grafting of nitrogen containing monomers onto poly(ethylene-alt-tetrafluoroethylene) films by bulk polymerization for proton exchange membranes, *J. Radioanal. Nucl. Chem.* 308 (2016) 1089-1094.
- [20] S. Neuhaus, C. Padeste, N.D. Spencer, Versatile wettability gradients prepared by chemical modification of polymer brushes on polymer foils, *Langmuir* 27 (2011) 6855-6861.

- [21] C. Baudin, J.P. Renault, S. Esnouf, S. Palacin, T. Berthelot, VUV grafting: an efficient method for 3D bulk patterning of polymer sheets, *Polym. Chem.* 5 (2014) 2990-2996.
- [22] M. Gabriel, M. Dahm, C.F. Vahl, Wet-chemical approach for the cell-adhesive modification of polytetrafluoroethylene, *Biomed. Mater.* 6 (2011) 035007 (5pp).
- [23] Technical bulletin of Fluoroetch®; <http://www.actontech.com/pdf/fss-tech-bull-rev-2003-0731.pdf> (Accessed 26 January 2018).
- [24] C. Löhbach, U. Bakowsky, C. Kneuer, D. Jahn, T. Graeter, H.J. Schäfers, C.M. Lehr, Wet chemical modification of PTFE implant surfaces with a specific cell adhesion molecule, *Chem. Comm.* 21 (2002) 2568-2569.
- [25] S. Wang, J. Li, J. Suo, T. Luo, Surface modification of porous poly(tetrafluoroethylene) film by a simple chemical oxidation treatment, *Appl. Surf. Sci.* 256 (2010) 2293–2298.
- [26] P. Castell, M. Wouters, G. de With, H. Fischer, F. Huijs, Surface Modification of Poly(propylene) by Photoinitiators: Improvement of Adhesion and Wettability, *J. Appl. Polym. Sci.* 92 (2004) 2341-2350.
- [27] B. Rånby, W.T. Yang, O. Tretinnikov, Surface photografting of polymer fibers, films and sheets, *Nucl. Instr. Meth. Phys. Res. B.* 151 (1999) 301-305.
- [28] T. Rohr, D.F. Ogletree, F. Svec, J.M.J. Fréchet, Surface functionalization of thermoplastic polymers for the fabrication of microfluidic devices by photoinitiated grafting, *Adv. Funct. Mater.* 13 (2003) 264-270.
- [29] H. Alwael, D. Connolly, P. Clarke, R. Thompson, B. Twamley, B. O'Connor, B. Paull, Pipette-tip selective extraction of glycoproteins with lectin modified gold nanoparticles on a polymer monolithic phase, *Analyst* 136 (2011) 2619-2628.
- [30] J. Krenkova, F. Foret, Nanoparticle-modified monolithic pipette tips for phosphopeptide enrichment, *Anal. Bioanal. Chem.* 405 (2013) 2175-2183.
- [31] H. Wang, H. Zhang, Y. Lv, F. Svec, T. Tan, Polymer monoliths with chelating functionalities for solid phase extraction of metal ions from water, *J. Chromatogr. A* 1343 (2014) 128-134.
- [32] T.B. Stachowiak, F. Svec, J.M.J. Fréchet, Patternable protein resistant surfaces for multifunctional microfluidic devices via surface hydrophilization of porous polymer monoliths using photografting, *Chem. Mater.* 18 (2006) 5950-5957.
- [31] R.J. Vonk, S. Wouters, A. Barcaru, G. Vivó-Truyols, S. Eeltink, L.J. de Koning, P.J. Schoenmakers, Post-polymerization photografting on methacrylate-based monoliths for

separation of intact proteins and protein digests with comprehensive two-dimensional liquid chromatography hyphenated with high-resolution mass spectrometry, *Anal. Bioanal. Chem.* 407 (2015) 3817-3829.

[32] J.C. Masini, Semi-micro reversed-phase liquid chromatography for the separation of alkyl benzenes and proteins exploiting methacrylate- and polystyrene-based monolithic columns, *Sep. Sci.* 39 (2016) 1648-1655.

[33] G. Çelik, M. Barsbay, O. Güven, Towards new proton exchange membrane materials with enhanced performance via RAFT polymerization, *Polym. Chem.* 7 (2016) 701-714.

[34] S.D. Poynton, R.C.T. Slade, T.J. Omasta, W.E. Mustain, R. Escudero-Cid, P. Ocón, J.R. Varcoe, Preparation of radiation-grafted powders for use as anion exchange ionomers in alkaline polymer electrolyte fuel cells, *J. Mater. Chem. A* 2 (2014) 5124-5130.

[35] P.J. Larkin, *Infrared and Raman Spectroscopy*, Elsevier, Oxford, 2011.

[36] T.T.H Dao, M. Guerrouache, B. Carbonnier, Thiol-yne click adamantane monolithic stationary phase for capillary electrochromatography, *Chin. J. Chem.* 30 (2012) 2281-2284.

[37] D. Horák, J. Straka, B. Schneider, F. Lednický, J. Pilar, Poly(ethylene dimethacrylate) particles with poly(glycidyl methacrylate) functionalities, *Polymer*. 35 (1994) 1195-1202.

[38] J. Chen, M. Asano, Y. Maekawa, T. Sakamura, H. Kubota, M. Yoshida, Preparation of ETFE-based fuel cell membranes using UV-induced photografting and electron beam-induced crosslinking techniques, *J. Membr. Sci.* 283 (2006) 373-379.