

Document downloaded from:

<http://hdl.handle.net/10251/194431>

This paper must be cited as:

Galindo, J.; Dolz, V.; Monsalve-Serrano, J.; Bernal-Maldonado, MA.; Odillard, L. (2022). EGR cylinder deactivation strategy to accelerate the warm-up and restart processes in a Diesel engine operating at cold conditions. *International Journal of Engine Research*. 23(4):614-623. <https://doi.org/10.1177/14680874211039587>



The final publication is available at

<https://doi.org/10.1177/14680874211039587>

Copyright SAGE Publications

Additional Information

This is the author's version of a work that was accepted for publication in *International Journal of Engine Research*. Changes resulting from the publishing process, such as peer review, editing, corrections, structural formatting, and other quality control mechanisms may not be reflected in this document. Changes may have been made to this work since it was submitted for publication. A definitive version was subsequently published as <https://doi.org/10.1177/14680874211039587>

EGR cylinder deactivation strategy to accelerate the warm-up and restart processes in a Diesel engine operating at cold conditions

J. Galindo, V. Dolz¹, J. Monsalve-Serrano, M.A. Bernal

CMT – Motores Térmicos, Universitat Politècnica de València, Spain

L. Odillard

VALEO – Thermal System, LE MESNIL SAINT DENIS CEDEX, France

Abstract

The aftertreatment systems used in internal combustion engines need high temperatures for reaching its maximum efficiency. By this reason, during the engine cold start period or engine restart operation, excessive pollutant emissions levels are emitted to the atmosphere. This paper evaluates the impact of using a new cylinder deactivation strategy on a Euro 6 turbocharged diesel engine running under cold conditions (-7°C) with the aim of improving the engine warm-up process. This strategy is evaluated in two parts. First, an experimental study is performed at 20°C to analyze the effect of the cylinder deactivation strategy at steady-state and during an engine cold start at 1500 rpm and constant load. In particular, the pumping losses, pollutant emissions levels and engine thermal efficiency are analyzed. In the second part, the engine behavior is analyzed at steady-state and transient conditions under very low ambient temperatures (-7°C). In these conditions, the results show an increase of the

¹ V. Dolz. CMT-Motores Térmicos, Universitat Politècnica de Valencia, Camino de Vera s/n, 46022 Valencia, Spain. Phone: +34 963877650 Fax: +34 963877659 e-mail: vidolrui@mot.upv.es

exhaust temperatures of around 100°C, which allows to reduce the diesel oxidation catalyst light-off by 250 seconds besides of reducing the engine warm-up process in approximately 120 seconds. This allows to reduce the CO and HC emissions by 70% and 50%, respectively, at the end of the test.

Keywords

EGR, Cylinder deactivation, Cold conditions, IC engine, Warm up, Exhaust Catalyst Activation

NOMENCLATURE

Acronyms

CDA	Cylinder Deactivation
VVT	Variable Valve Timing
EGR	Exhaust Gas Recirculation
HP	High Pressure
LP	Low Pressure
ICE	Internal Combustion Engine
HEV	Hybrid Electric Vehicle
WLTP	Worldwide harmonized Light vehicle Test Procedure
NO _x	Nitrogen Oxides
CO	Carbon Monoxides
HC	Hydrocarbons
PM	Particulate Matter
ECU	Electronic Control Unit
DPF	Diesel Particulate Filter
GPF	Gasoline Particulate Filter
DOC	Diesel Oxidation Catalyst
SCR	Selective Catalyst Reduction
ET	Exhaust Throttle
BDC	Bottom Dead Center
BSFC	Brake Specific Fuel Consumption
IMEP	Indicated Mean Effective Pressure
PID	Proportional Integral Derivative
WCAC	Water Charge Air Cooler
VGT	Variable Geometry Turbine

Notation

Latin

W	Work	J
P	Pressure	bar
V	Volume	cm ³

Subscripts

exh	Exhaust gases side
int	Intake air
amb	Ambient conditions
i	Indicated

1. Introduction

People and goods transport is a fundamental activity for the development of modern societies. To achieve this goal, it is necessary to develop efficient light vehicles with low fuel consumption and low pollutant emissions. Among the different powertrains that can be used in these vehicles, the internal combustion engine (ICE) remains the most used powertrain for this application. Considering future predictions [1], global average car ownership will increase from 129 cars per thousand people in 2014 to 238 cars per thousand people in 2050. The more developed countries generally maintain their ownership levels at around 350–450 cars per thousand people. But other countries as China and India will experience an important growth, from 89 and 16 cars per thousand people respectively in 2014, to 286 and 222 cars per thousand people in 2050. With the aim of reducing the environmental impact of the vehicles use, stringent regulations are being continuously introduced around the world [2] [3].

The operation conditions of the test drive for these newer regulations will consider the effect of running at lower ambient temperature [4]. For example, the recent

Euro 6d regulation includes the engine operation at -7°C . Considering this context, the fuel consumption and pollutant emissions during the engine warm-up become as critical parameters. According to the literature [5] [6] [7], unburned hydrocarbons (HC) and carbon monoxide (CO) are mainly emitted when the engine temperatures remain low due to the strong temperature dependence of the aftertreatment systems to reach its maximum efficiency. This is particularly important in the hybrid electric vehicles (HEV), in which the shut-off and engine restart occur more often, introducing a key challenge to keep the aftertreatment temperature at the pertinent levels. Another consequence of operating at low ambient temperature is the exhaust gas recirculation (EGR) limitations and its dependency with the nitrogen oxides (NO_x) concentration and the particulate matter (PM) and condensation generated at these conditions [8] [9]. In this sense, it is proved that accelerating the warm-up process and increasing the engine temperatures can provide benefits such as HC and CO emissions reduction, combustion noise control and engine stability improvement after the cold start, besides of the possibility of implement different and enhanced warm-up and EGR calibration strategies [10] [11] [12].

In the recent years, different strategies have been developed to improve the thermal efficiency of the ICE and accelerate its thermal transient. Some of these strategies are the cylinder cutout [13] or the variable valve timing (VVT) [14] [15], which can be combined with novel strategies as the cylinder ventilation [16]. Another strategy that offers good results is the cylinder deactivation (CDA) [17] [18]. This strategy helps to reduce the fuel consumption and increase the exhaust temperature up to 100°C , thus activating the aftertreatment systems in shorter times. The oxidation catalyst and selective catalytic reduction (SCR) systems

have strong temperature dependencies, even, the diesel and gasoline particulate filter (DPF, GPF) must be periodically regenerated with high exhaust gases temperatures [19] [20]. By this reason, CDA strategy could be presented as a reasonable operating condition for modern ICEs working at very low ambient temperatures (-7°C).

Several authors have considered this strategy with different objectives. Zammit et al. [21] studied this strategy on a 2.2 l diesel engine by deactivating two of the four cylinders at steady-state conditions at 1500, 2000, and 2500 rpm. The authors concluded that the CDA strategy has no effect or improvement on the brake specific fuel consumption (BSFC) and NO_x emissions levels, but it can reduce the HC and CO emissions and increase the exhaust temperature by up to 120°C. Another group of authors, Gritzenko et al [22], performed a theoretical and experimental study on a 2 l diesel engine by using three different cylinder deactivation strategies. The objective of these strategies was to evaluate the engine efficiency at different stationary regimes from 1200 to 2350 rpm. The results of this work reported benefits in fuel consumption due to improvements in combustion efficiency.

According to the previous paragraphs, the study of the cylinder deactivation strategy becomes especially interesting as a solution to reduce the warm-up process and decrease the after-treatment systems activation when ICEs operate at cold conditions (-7°C). In this paper, a new method of deactivating cylinders, called EGR DEACT (Fig.1), is proposed. Meaning that the cylinders are not deactivated by the valves closure, but with the 100% of exhaust gas recirculation dedicated to the deactivated cylinders. This strategy allows to keep positive in-cylinder pressure (no blow-by risk) and could be presented as a cheaper solution

compared to the intake and exhaust valve closing solution. Taking this into account, the main findings of this work are presented in two sections. First, an analysis of the pumping losses presented when a cylinder works only under compression and expansion processes. Moreover, an experimental study of the EGR DEACT strategy performed at 20°C ambient temperature in order to know the engine response at steady-state and transient conditions working with this configuration and set a reference to compare the engine performance under cold operating conditions (-7°C). Finally, the main results and effects of using the EGR DEACT strategy at steady-state conditions and during the engine cold start on the regulated diesel emissions and the engine thermal efficiency are presented and compared.

2. Experimental setup and methodology

2.1. Test bench description and configuration

In order to perform this experimental work, an in-line 4 cylinders, 1.6 l, turbocharged, diesel engine was used. Table 1 summarizes the technical features of the engine used. To carry out the experiments, the engine was installed in a climatic test bench, where the temperatures of the test bench air, fuel and coolant are under control. The test bench is instrumented to measure the torque, speed, temperatures and pressures at different engine points. The injected fuel mass and the air mass flow through the intake line are also measured.

Table 1. Engine Specifications

Number of Cylinders	4
Number of Valves	16
Bore x Stroke (mm)	80 x 79.5
Total Displacement (cc)	1598
Maximum Power (kW/rpm)	96/4000
Maximum Torque (Nm/rpm)	320/1750
Compression Ratio	15.4 : 1
Turbocharger	Variable Geometry Turbine (VGT)
Fuel Injection System	Common Rail Direct Injection
EGR System	HP and LP Cooled EGR
Intake Cooling System	Water Charge Air Cooler (WCAC)

Fig. 1 a) shows the standard engine configuration and its instrumentation. The engine has two EGR circuits. The first one is the high pressure (HP) EGR circuit, in which the exhaust gas is directly cooled in the cylinder head and mixed up with the fresh air coming from the intake line. However, for this particular study, this circuit will be modified. The second circuit is the low pressure (LP) EGR. In this case, the exhaust gas passes through the catalyzer and the particulate filter, and then is driven and distributed to the engine intake line and mixed up with the air at the compressor inlet. This gas mixture is compressed and directed to the engine intake manifold, where it is introduced into the four cylinders. The water charge air cooler (WCAC) is not activated (0 flow inside) during the cold start operation.

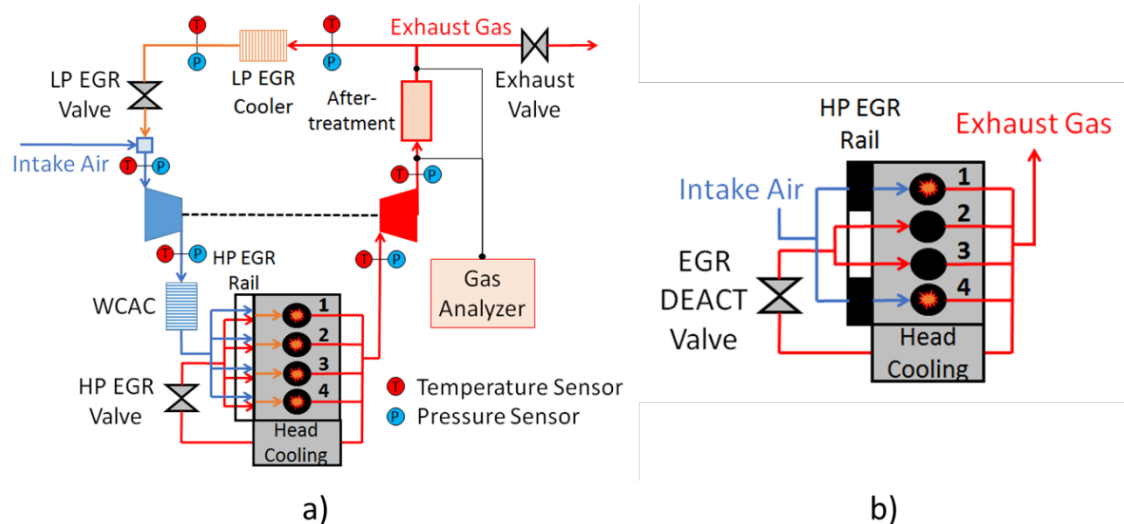

Fig. 1. a) Standard Engine Configuration b) EGR DEACT Configuration

Fig. 1 b) shows the EGR DEACT configuration, fired cylinders (1 and 4) and deactivated cylinders (2 and 3). In order to deactivate the cylinders 2 and 3, the injectors has been unplugged and two external injectors has been plugged to the electronic control unit (ECU) connector. In addition, the engine intake manifold and the HP EGR rail have been modified, closing the air inlet of the cylinders 2 and 3 and closing the HP EGR inlet of the cylinders 1 and 4 with the aim of reducing pumping losses in the circuit. The HP EGR valve (renamed as EGR DEACT valve) is now controlled manually through a proportional integral derivative (PID) controller and an external valve has been fitted to the ECU connector in order to avoid mistakes in the engine calibration due to the valve position measurement. In the fired cylinders 1 and 4, only the LP EGR is enabled and the whole intake air is distributed to the cylinders inlet.

Several engine parameters were measured to assess the engine performance and analyze the impact of the proposed configuration. The measured parameters together with the sensors features are presented in Table 2.

Table 2. Instrumentation Accuracy

Sensor	Variable	Accuracy [%]	Range
Thermocouples type K	Temperature	1	-200-1250°C
Pressure sensor	Pressure	0.3	0-10bar
Gravimetric fuel balance	Fuel mass flow	0.2	0-150kg/h
Hot wire meter	Air mass flow	1	0-720kg/h
Dynamometer brake	Torque	0.1	0-480Nm

In-cylinder pressure data was acquired using a Kistler 6537A4Q59 piezoelectric pressure sensor fitted with a standard water-cooled Kistler 7061B precision pressure transducer and coupled to a Kistler 4603 piezoresistive amplifier. The pressure signal from these transducers is normally converted to an absolute value by referencing the signal at the inlet bottom dead center (BDC) to the intake manifold pressure. The pressure data was sampled every 0.5 °crank angle by the shaft encoder and ensemble averaged over 50 cycles. This data was recorded using the NI LabVIEW software, and post-processed to determine the Indicated mean effective pressure (IMEP) and the pumping losses.

A Horiba Mexa 7100 DEGR was used to measure O₂, CO₂, CO, using a non-dispersive infrared analyzer, and unburned hydrocarbons with a chemiluminescent detector. The error of the gas analyzer is in the range of 2%. The measurement point is located downstream the turbine and upstream after-treatment systems.

The LP EGR rate has been obtained experimentally from the CO₂ measurement in exhaust and intake manifolds using the following expression:

$$LP\ EGR_{rate} = \frac{[CO_2]_{Int} - [CO_2]_{Amb}}{[CO_2]_{Exh} - [CO_2]_{Amb}} \quad (1)$$

2.2. Methodology and Strategies

In order to compare the pollutant emissions and exhaust gas temperatures for the EGR DEACT engine (2 cylinders firing) and standard engine (4 cylinders firing), steady and transient points were measured at an engine speed of 1500 rpm and a constant load of approximately 30 Nm at 20°C. For transient conditions, an engine cold start is performed until the warm-up process finishes, that is when the engine coolant strategy changes at an engine coolant temperature of 72°C. Then, the same methodology was replied to perform the study at cold conditions (-7°C). This engine operating point is a representative working point during the diesel engines homologation in the Worldwide harmonized Light vehicle Test Procedure (WLTP). Moreover, it is a representative working point studied in previous research works [23].

For the EGR DEACT configuration, it was necessary to modify the engine calibration in order to follow the fuel injection strategy and the EGR strategy of the standard engine from the beginning of the warm up process in a cold starting of the engine at 20°C and -7°C. The standard engine calibration is not configured for working with deactivated cylinders at cold conditions and presented some constraints in the fuel delivery and boost pressure [21]. These modifications were done with the purpose of keeping isobaric conditions (constant load) for both configurations, offering to the customer the same engine performance when the EGR DEACT strategy is activated.

Fig. 2 shows the standard and the EGR DEACT fuel injection strategy. Working with the standard engine (4 cylinders), two pre-injections of fixed quantity (1.5 mg/stroke) followed by a main injection, with a fixed separation of 650 μ s are performed. Working with the EGR DEACT engine (2 cylinders), two pre injections of fixed quantity (1.5 mg/stroke) followed by a main injection, with a fixed separation of 650 μ s and a post injection of fixed quantity (10 mg/stroke) without separation are performed. This additional fuel was added due to the engine calibration limitations and with the aim of reaching a similar torque and working with similar air fuel ratio (A/F) values than the standard engine configuration (4 cylinders).

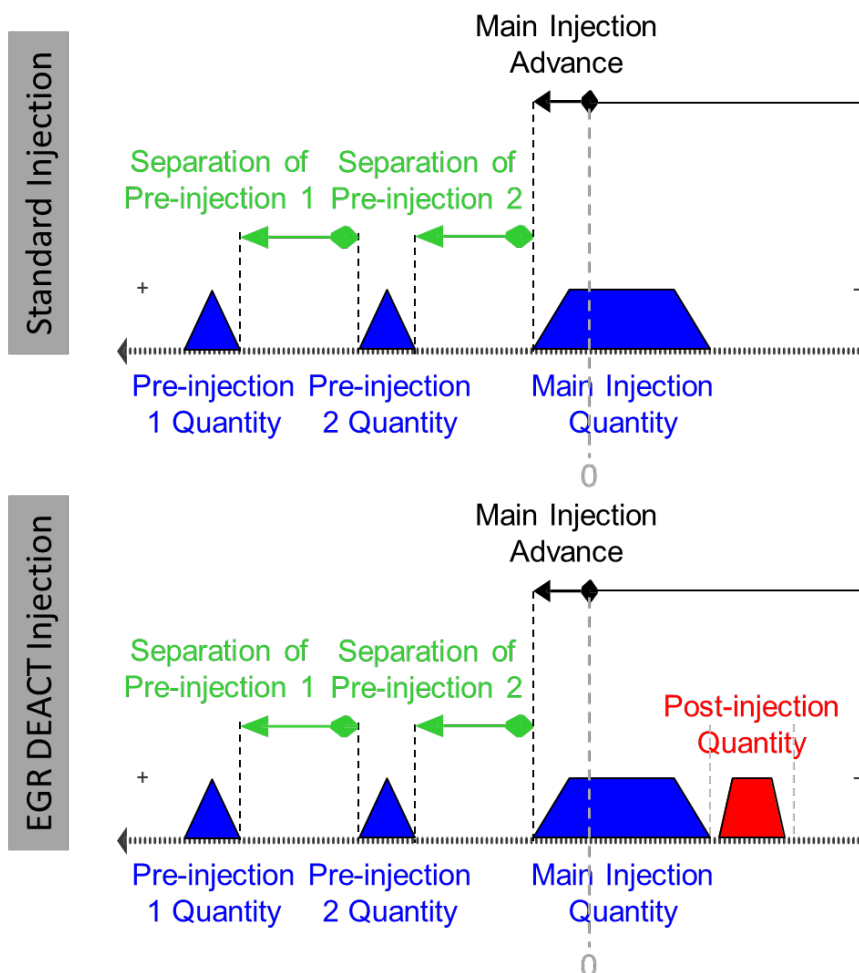

Fig. 2. Standard and EGR DEACT Fuel Injection Strategy

Regarding the boost constraints, the exhaust gas flow rate through the deactivated cylinders (2 and 3) was controlled by the position of the EGR DEACT valve, while the turbine vanes were actuated manually trying to follow the requested boost pressure. The increased exhaust mass flow resulting from the displacement of intake air in the fired cylinders (1 and 4) and the exhaust mass flow regulation in the deactivated cylinders (2 and 3), could contribute directly to modify the engine pumping losses and the pressure before turbine. The torque limitations as a function of the variable geometry turbine (VGT) position and the engine pumping losses are presented in Fig. 3. This figure illustrates the trade-off between the boost setting and the pumping loss when running on EGR DEACT engine (2 cylinders). It can be observed how the measured points in the central part of the map, closing the turbine vanes from 40% onwards and EGR DEACT valve positions between 30 and 70%, present the higher torque values for this engine configuration. These values have been taken as reference parameters in order to perform this experimental work.

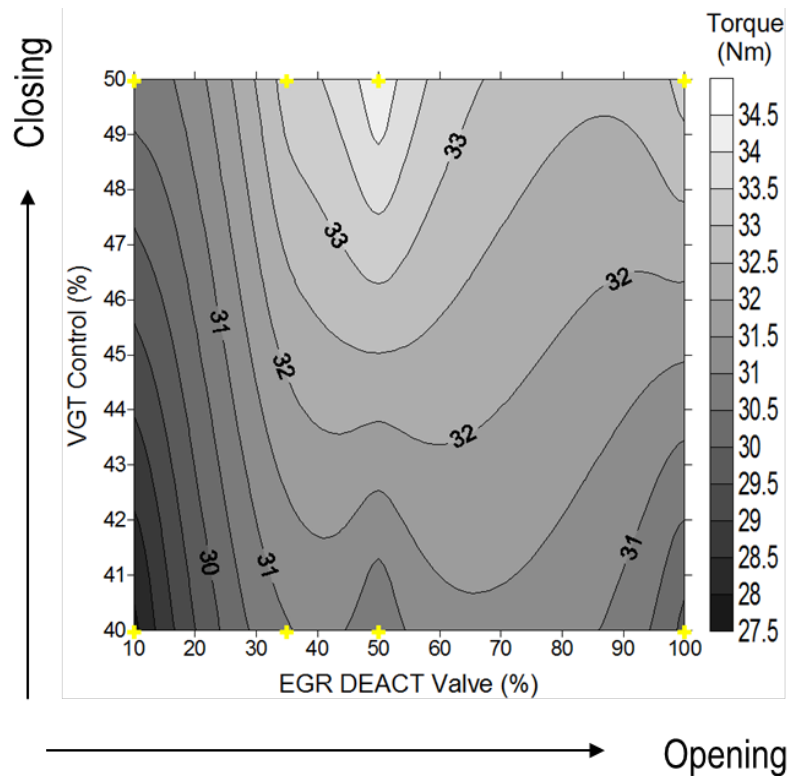

Fig. 3. Torque limitations in function of VGT and EGR DEACT Valve position – 1500rpm

Besides of controlling the fuel injection settings and VGT position, variables like the LP EGR valve position and exhaust throttle (ET) valve position have been controlled in order to look for an optimal engine calibration in terms of pollutant emissions and thermal management.

3. Experimental study at ambient temperature (20°C)

Steady and transient points have been measured at ambient temperature (20°C) with the aim of identifying the engine response when it works with the EGR DEACT configuration. The purpose of this is to compare the standard engine operation with the modified strategy, analyzing the in-cylinder pressures, the pollutant emissions and the engine thermal efficiency to subsequently replicate these results working at cold conditions (-7°C).

3.1 Pumping Losses Analysis

First, in order to analyze the pumping losses induced by the deactivation of cylinders 2 and 3, an estimation of the indicated work per cycle as a function of EGR DEACT valve position is presented. Then, the pollutant emissions trends and the thermal analysis at steady and transient conditions is discussed.

It is important to highlight the fact that this analysis was done to assess the pumping losses consequently introduced by the EGR DEACT routing, having an unrepresentative EGR routing permeability layout (mass production EGR valve, recirculation across to small HP EGR holes, etc.)

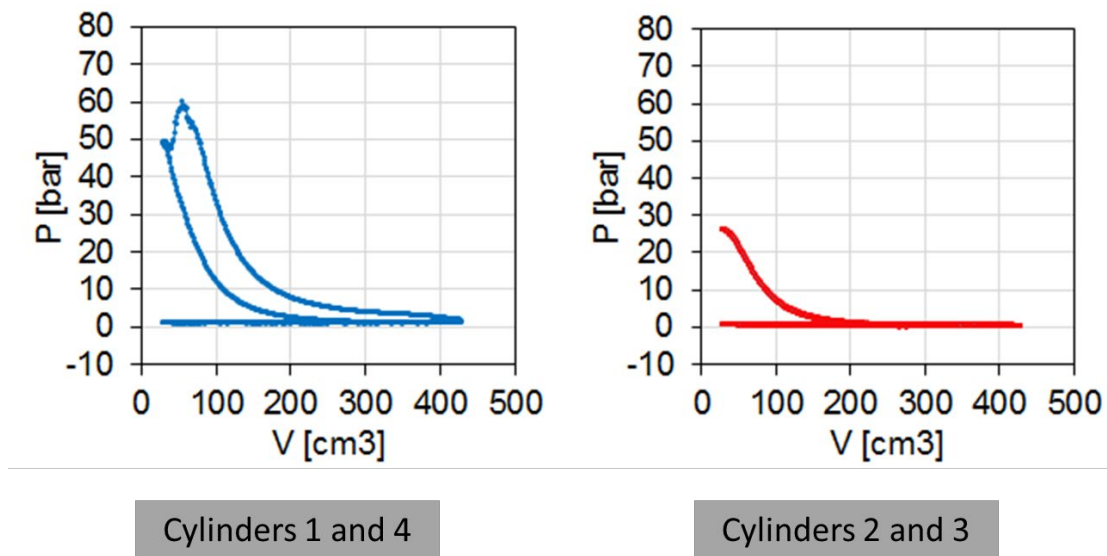

Fig. 4. Indicated Diagram Profile ($P - V$) for the EGR DEACT Configuration

Fig. 4 shows an example of the indicated diagram profile measured when the cylinder presents a combustion and under the EGR DEACT configuration. This diagram is used to estimate the indicated work per cycle and the pumping work considered also as mechanical losses. In fired cylinders (1 and 4), it could be assumed the compression and power strokes as the positive work obtained from

the cycle while the exhaust and intake strokes as the negative work. In deactivated cylinders (2 and 3), due to the fuel cut, there is not a power stroke in the cylinders and by this reason the complete cycle could be considered as a negative work that should be countered and minimized.

Taking this into account, using the indicated diagram, the in-cylinder pressures measured in the four cylinders and the engine cylinder capacity, the indicated work per cycle and the pumping work are estimated as is shown in the following equation.

$$W_i = \int_0^\alpha P \cdot dV \quad (2)$$

Working with the standard engine (4 cylinders firing) a total indicated work per cycle of approximately 700 J is estimated. This value is the sum of the indicated work estimated by each cylinder. On the other hand, Table 3 shows that working with the EGR DEACT strategy (2 cylinders firing) and regulating the EGR DEACT valve position between 35% and 50%, allows to reach a maximum indicated work of approximately 655 J and a considerable reduction of the pumping losses by 50%. However, the exhaust gas temperature is reduced due to a higher mass of gas recirculating in the deactivated cylinders (2 and 3). Moreover, a reduction in the effective work (engine torque) delivered by the engine using this configuration is noted. Taking this into account, some discrepancies are observed between the evolution of the indicated work and pumping work, which are estimated from the instantaneous pressures in the cylinder, and the torque, which is measured directly on the shaft. If the 35% and 50% EGR points are compared, when the indicated work increases and the pump work decreases, the torque decreases slightly, which does not make sense. Although the estimations of indicated work

and pumping work were made by averaging the value of different cycles to avoid dispersion errors, these small discrepancies could not be avoided. Due to these discrepancies, it was preferred to use torque, which is a direct measure, as a parameter to optimize. Consequently, 35% EGR was chosen as the optimum operating point as it presented the point with the maximum torque and showed high values of temperature in the exhaust.

Table 3. Indicated work and pumping losses estimation

EGR DEACT Valve Position (%)	Turbine Outlet Temperature (°C)	Indicated Work (J)	Pumping Work (J)	Torque (Nm)
10	298	637.4	74	27.8
35	275	654.4	48.6	30.9
50	247	656.4	37.7	30.4
100	245	653	32.1	29.8

3.2 Results at steady-state conditions

Steady state points measured at 1500 rpm and constant load using the EGR DEACT engine configuration (2 cylinders firing) are compared with the standard engine configuration (4 cylinders firing). These tests are performed with the engine in hot conditions (85°C coolant temperature) and ambient temperature (20°C), measuring raw pollutant emissions and using the EGR DEACT injection strategy mentioned in the section 2.2. In addition, parameters like post injected

fuel of 10 mg/stroke, VGT opening at 50%, EGR DEACT valve position at 35% and LP EGR valve opening at 60% are fixed.

Table 4 shows the torque, exhaust gas temperature and pollutant emissions for the tests in both configurations. Keeping a constant torque value of approximately 30 Nm for both configurations, an increase of 70°C in the turbine outlet temperature (after-treatment inlet) was achieved using the EGR DEACT strategy. In addition, a reduction of 50% and 40% of the HC and CO emissions, respectively, was achieved. However, a noticeable NO_x emissions increase and a fuel mass increase of 15% were found using this engine configuration.

The NO_x emissions increase could be related with the boost limitations and the lower EGR rate performed in the firing cylinders. Under standard engine configuration, EGR rates of approximately 50% are reached. Besides, according with the literature the new exhaust gas recirculation distribution and its dispersion could contribute to increase the NO_x and PM emissions depending of the mixing behavior [24] [25].

Table 4. Engine performance at 20°C

Parameter	Standard Engine (4 Cylinders)	EGR DEACT Engine (2 Cylinders)
Torque (Nm)	30.5	31
Turbine Outlet T. (°C)	229	299
NO _x (g/kWh)	0.6	4.8

HC (g/kWh)	1.8	0.95
CO (g/kWh)	6.5	3.9
Fuel Mass (kg/h)	1.36	1.61

3.3 Results in transient conditions

Once the engine response at steady-state conditions and working under EGR DEACT configuration is known, the engine warm-up process at transient conditions is evaluated.

Figure 5 presents the engine torque response along the first minutes of an engine cold start at 20°C. First, a reference test (Ref_Test) working with the standard engine at 1500 rpm was carried out. Then, two tests working with the EGR DEACT engine (Test 1 and Test 2) were performed trying to follow the reference test. The net pollutant emissions were measured during the Test 1 and the raw pollutant emissions were measured during the Test 2. In order to follow this operating condition, the parameters established at steady-state conditions in the methodology section are replied working under this transient condition.

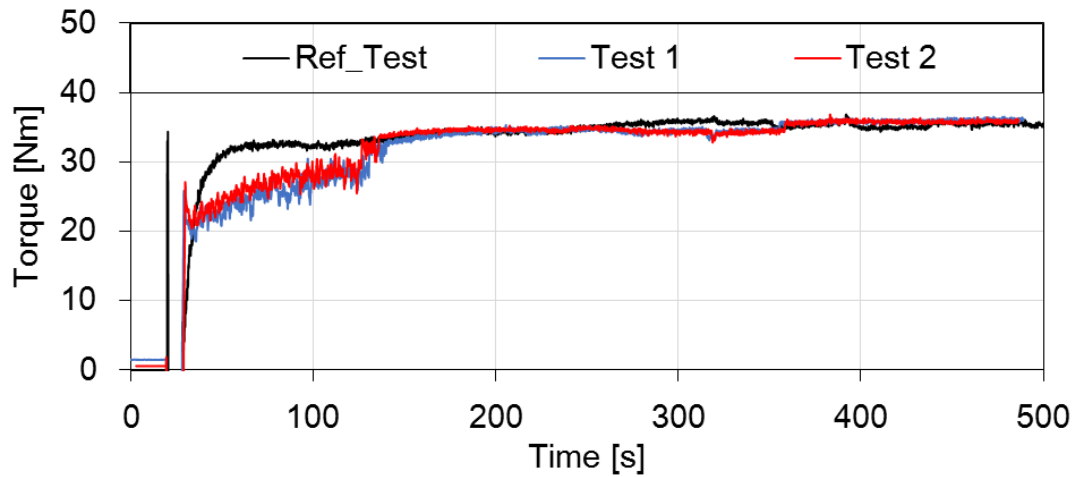

Fig. 5. Torque at 20°C

The engine thermal efficiency and the short activation of the after-treatment system depends on the engine warm-up and the outlet temperatures reached in the exhaust line. Figure 6 shows the engine coolant temperature and the exhaust temperature measured at the turbine outlet (DOC inlet) in order to check the after-treatment activation period and its efficiency. A temperature increase of approximately 60°C can be observed in the exhaust gases after the engine cold start (second 120) due to the EGR DEACT method implementation. This advantage could reduce the engine warm-up process up to 60 seconds and the after-treatment activation up to 100 seconds, improving the thermal efficiency of the DOC and its functioning. Oxidation catalyst and lean NO_x trap (LNT) devices deliver its maximum efficiency when the exhaust gas temperature is beyond 200°C [26][27].

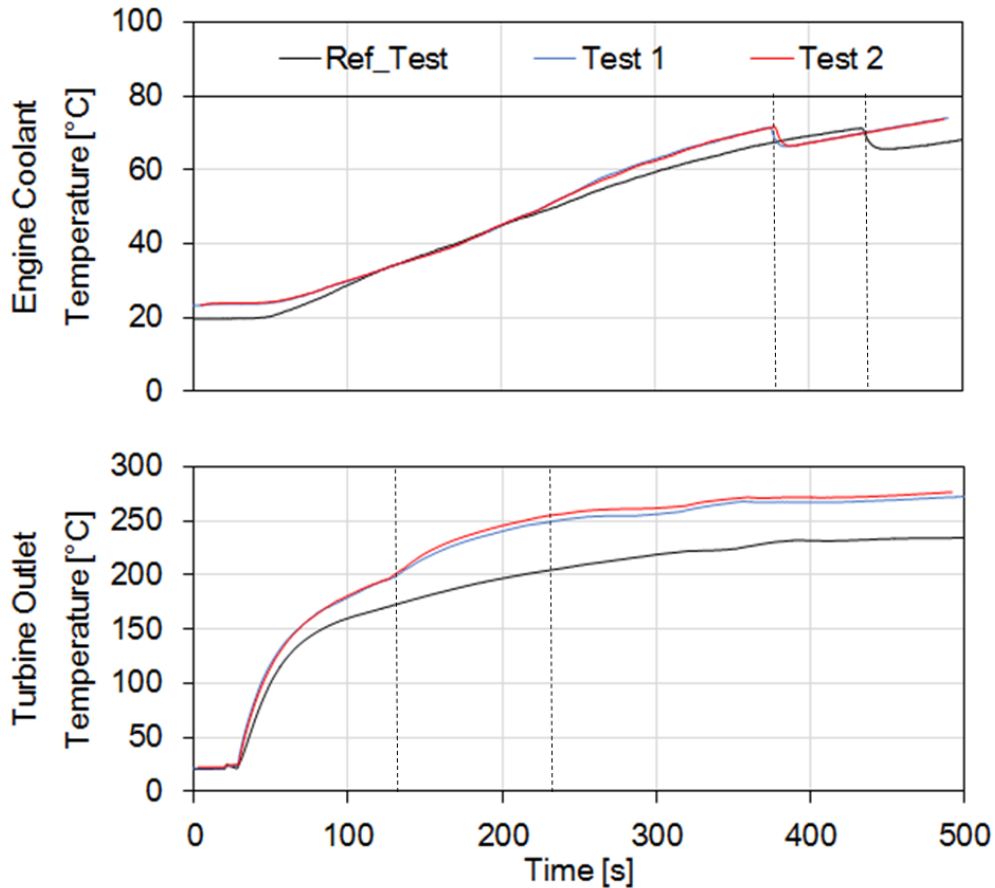

Fig. 6. Engine coolant and turbine outlet temperature at 20°C

Due to the higher exhaust temperatures, a reduction in HC and CO emissions should be expected. Figure 7 presents the pollutant emissions measurements upstream and downstream of the after-treatment system. On the top of the graph it can be observed a considerable NO_x emissions increase due to the EGR limitations. Fixing the LP EGR valve position at 60% and activating the exhaust throttle (ET) valve also at 60%, a maximum EGR rate of 15% was performed. This limitation could be related to a low pressure difference between the intake and exhaust manifolds due to the boost limitations evidenced before. Table 5 presents how closing the ET valve is an alternative to increase the EGR rate performed.

Table 5. EGR rate limitations

LP EGR Valve Position (%)	Exhaust Throttle Valve Position (%)	EGR Rate (%)
60	50	11.4
60	60	14.2
60	70	20.3

On the other hand, CO and HC emissions present a significant reduction during the engine cold start of 60% and 50% respectively. This benefit could be directly related with the higher exhaust temperatures evidenced before. In addition, comparing net and raw CO emissions, a reduction in the DOC light-off period (instant when the working temperature is reached) of approximately 250 seconds can be observed.

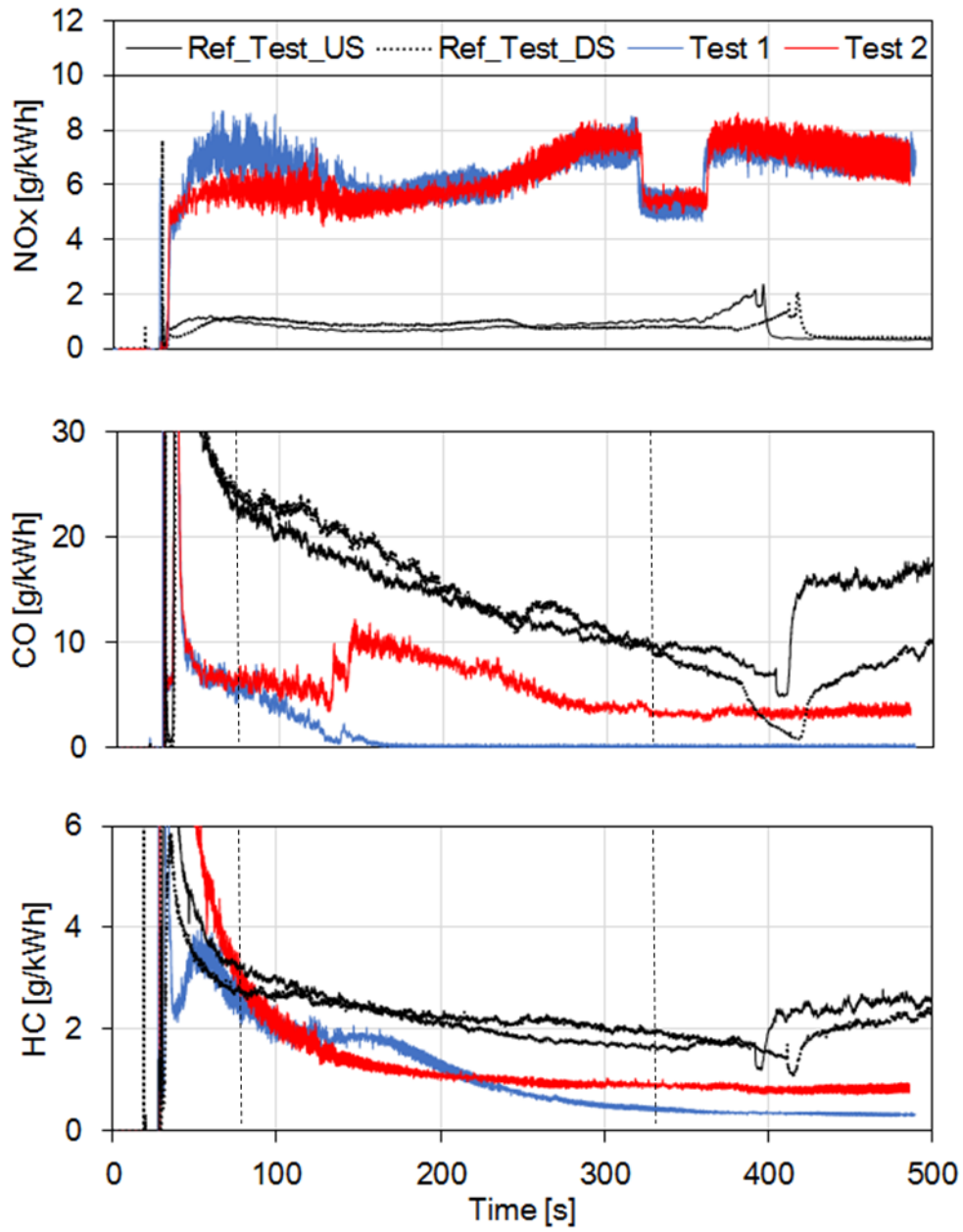

Fig. 7. Engine pollutant emissions at 20°C

4. Experimental study at cold conditions (-7°C)

A significant contribution of this experimental work is to evaluate the EGR DEACT strategy under low ambient temperature (-7°C). Taking this into account, and using the study performed at ambient temperature (20°C) as a reference, the engine is tested at steady-state and transient conditions under these particular conditions, trying to follow a similar performance than the observed before.

4.1 Results at steady-state conditions

Steady points measured at 1500 rpm and constant load using the EGR DEACT engine configuration are compared to the standard engine configuration. These tests are performed with hot engine (85°C coolant temperature) and low ambient temperature (-7°C).

The main results of this experiment are presented in Table 6. Keeping a constant value of approximately 38 Nm of torque for both configurations, a noticeable increase of 120°C in the turbine outlet temperature (after-treatment inlet) was achieved. In addition, a reduction of 70% and 40% in HC and CO emissions, respectively, was found. A NO_x emissions reduction of 16% and an acceptable fuel mass increase of 15% was achieved working at -7°C. This reduction in NO_x is achieved taking as a reference that the engine is not prepared to perform exhaust gas recirculation at this particular temperature. In the 20°C case the engine performed exhaust gas recirculation from the engine start. However, these results shows the potential of the EGR DEACT strategy in order to increase the exhaust gases temperature and its benefits when the ICE is working at low ambient temperatures.

Table 6. Engine performance at -7°C

Parameter	Standard Engine (4 Cylinders)	EGR DEACT Engine (2 Cylinders)
Torque (Nm)	38.1	37.2
Turbine Outlet T. (°C)	214	336.5
NOx (g/kWh)	3.2	2.7
HC (g/kWh)	1.9	0.6
CO (g/kWh)	10	6.3
Fuel Mass (kg/h)	1.59	1.91

4.2 Results in transient conditions

Working in transient conditions and starting the engine at a very low ambient temperature (-7°C) with exhaust gas recirculation from the beginning of the test causes instabilities and degradations of the combustion process. Figure 8 shows a reference test of an engine cold start performed with the standard engine (4 cylinders firing) and a single test performed with the EGR DEACT strategy (2 cylinders firing). Tests are performed using the same engine parameters fixed in the experimental study at 20°C. Following the torque evolution, it can be observed that working with the EGR DEACT configuration the warm up process of the engine is critical even decreasing the total work delivered by the engine, especially during the initial seconds of the test. This behavior is due to the soon EGR activation and the lower capacity of the engine when it works with only two

cylinders. Nevertheless, once the engine temperature increases and the warm up process finishes around the 200 seconds, the engine behavior begin to be stable.

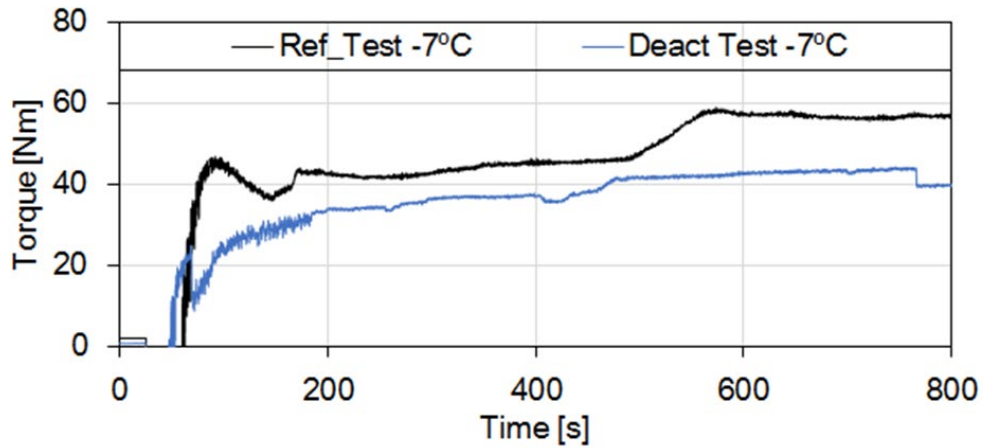

Fig. 8. Torque at -7°C

One improvement of this strategy is the reduction of the warm up process under these particular conditions. Figure 9 shows how the exhaust gas temperature is increased around 100°C reducing the engine warm up period in approximately 180 seconds (3 minutes) with respect to the reference case, a noticeable time reduction that allows to improve the engine behavior and to reduce the activation time of the after-treatment systems with the consequently benefits in pollutant emissions.

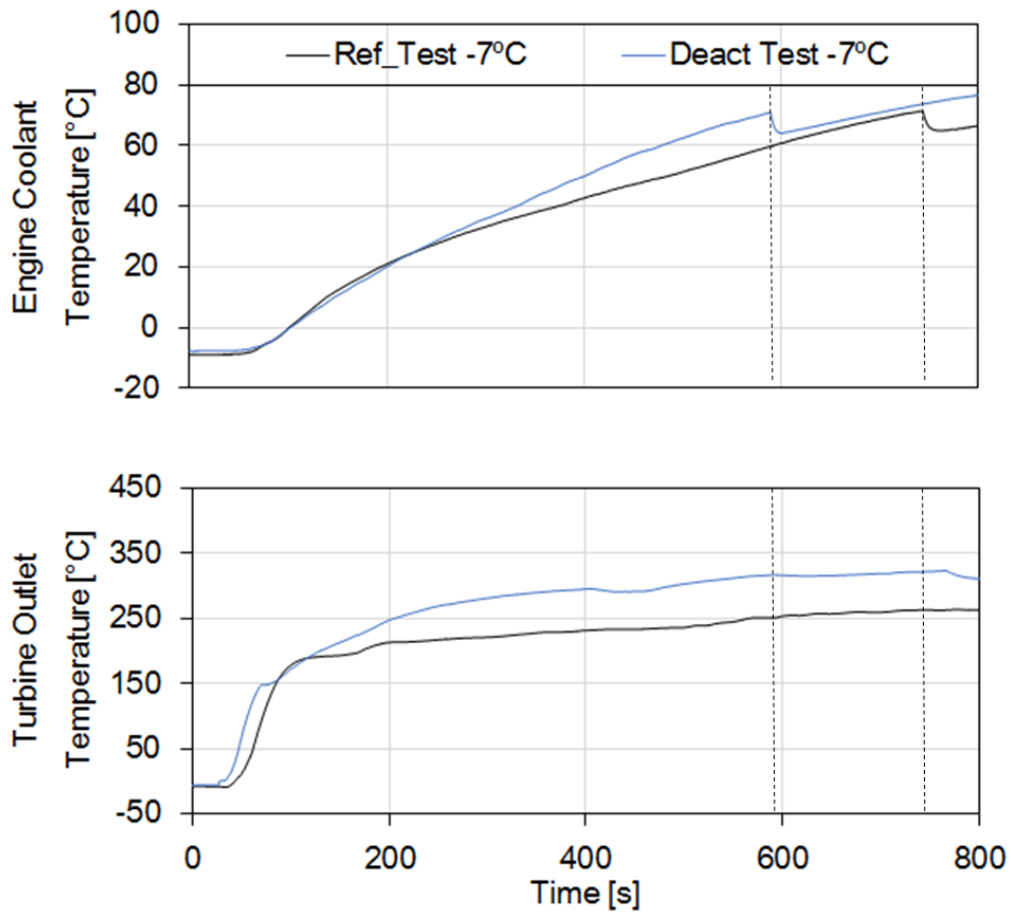

Fig. 9. Engine coolant and turbine outlet temperature at -7°C

Figure 10 presents the raw pollutant emissions measurements of these tests. Higher values of NO_x are evidenced during the first minutes of the cold start engine for the EGR DEACT strategy. However, when temperatures begin to increase, these levels decrease compared to the reference test. As it was founded at transient conditions and working at ambient temperature (20°C), CO and HC emissions are reduced in approximately 50% due to the higher temperatures reached in the exhaust gases.

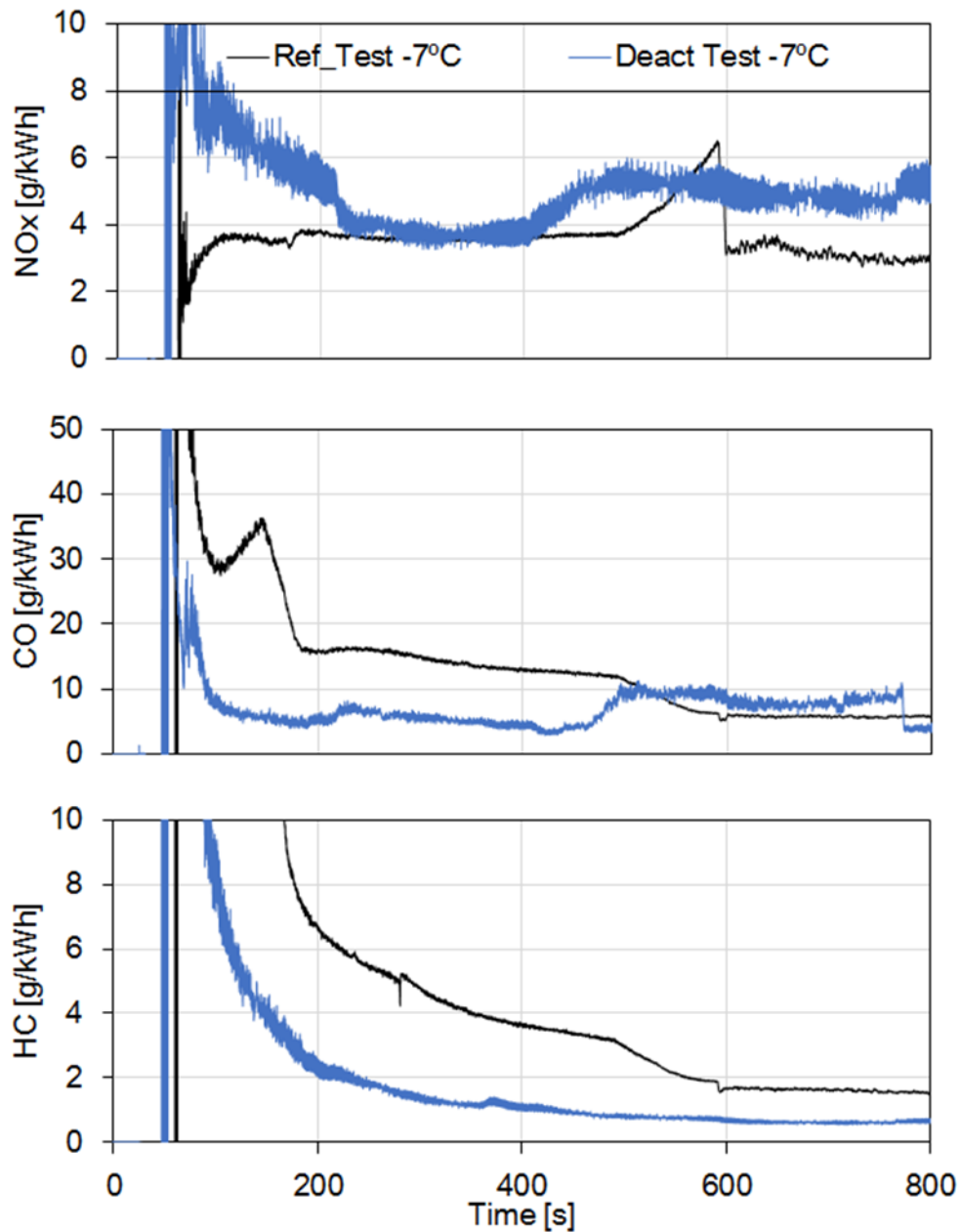

Fig. 10. Engine pollutant emissions at -7°C

5. Conclusions

In the present paper, the main advantages and disadvantages of implementing a new method of the cylinder deactivation strategy, called EGR DEACT, in a diesel engine working at very low ambient temperature (20°C and -7°C) have been studied and analyzed. The impacts in pollutant emissions, pumping losses and engine warm-up process were presented.

From the experimental study performed at 20°C, the main conclusions are related with the engine performance:

- The EGR DEACT engine behavior (2 cylinders) could be improved by optimizing the injection settings in the ECU (e.g. total injected fuel, injection time, etc.), in order to reproduce same conditions than the standard engine (4 cylinders).
- In order to reproduce the same turbocharger conditions, the VGT can be closed between 30% and 50%, increasing the turbocharger speed to the turbocharger standard conditions, but also increasing the A/F ratio.
- In order to reduce A/F ratio and reproduce similar EGR rates, the LP EGR valve can be opened to higher values, but it does not increase the EGR ratios in the cylinders 1 and 4 (there is not enough delta pressure between exhaust and intake lines to increase EGR rate). Maximum values of LP EGR rates in cylinders 1 and 4 are close to 10%, which is lower than with the standard engine case (50%). However, closing the exhaust throttle valve it can be possible to obtain an additional delta pressure and increase the EGR rate ratio to 20% reducing at the same time the NO_x emissions levels.
- The pumping losses is another important parameter to take into account when the EGR DEACT strategy is activated. Using this particular engine configuration (not “tailor made” EGR routing), it is necessary to find a trade-off between the mass flow recirculated in the deactivated cylinders and the maximum torque delivered by the engine in order to reduce the negative impact produced by the pumping work. A fully adapted EGR

routing layout combined with a simpler ON/OFF actuator should solve this issue.

- The EGR DEACT engine configuration (2 cylinders) in transient conditions (engine start) allow to advance the DOC light-off period in 250 seconds approximately compared with the standard engine configuration (4 cylinders).

The main findings of this work, taking the previous study as a reference and evaluating the engine performance working at cold conditions (-7°C), are the noticeable increment in the exhaust gas temperature at the after-treatment inlet in approximately 100°C , reducing the activation period of the device and reducing the engine warm-up process significantly. The CO and HC emissions reduction of 70% and 50% respectively is another important benefit using this engine configuration. Regarding the NO_x emissions, they remain more or less constant in comparison with the reference test at -7°C , nevertheless, a NO_x after-treatment device could reduce these emissions levels.

6. Acknowledgements

The authors thank to Juan Antonio López for his contribution in the testing process. Authors want to acknowledge the support of “Programa de Ayudas de Investigación y Desarrollo (PAID-01-17) de la Universitat Politècnica de València”.

REFERENCES

- [1] H. Hao, Y. Geng, and J. Sarkis, "Carbon footprint of global passenger cars: Scenarios through 2050," *Energy*, vol. 101, pp. 121–131, 2016.
- [2] N. Hooftman, M. Messagie, J. Van Mierlo, and T. Coosemans, "A review of the European passenger car regulations – Real driving emissions vs local air quality," *Renew. Sustain. Energy Rev.*, vol. 86, no. January, pp. 1–21, 2018.
- [3] G. Fontaras and P. Dilara, "The evolution of European passenger car characteristics 2000-2010 and its effects on real-world CO₂ emissions and CO₂ reduction policy," *Energy Policy*, vol. 49, no. 2012, pp. 719–730, 2012.
- [4] E. C.-O. J. E. Union and undefined 2008, "Commission Regulation (EC) No 692/2008 of 18 July 2008 implementing and amending Regulation (EC) No 715/2007 of the European Parliament and of the."
- [5] J. M. Luján, H. Climent, S. Ruiz, and A. Moratal, "Influence of ambient temperature on diesel engine raw pollutants and fuel consumption in different driving cycles," *Int. J. Engine Res.*, 2018.
- [6] J. M. Luján, H. Climent, L. M. García-Cuevas, and A. Moratal, "Pollutant emissions and diesel oxidation catalyst performance at low ambient temperatures in transient load conditions," *Appl. Therm. Eng.*, vol. 129, no. 2, pp. 1527–1537, 2018.
- [7] F. J. Arnau, J. Martín, P. Piqueras, and Á. Auñón, "Effect of the exhaust

- thermal insulation on the engine efficiency and the exhaust temperature under transient conditions,” *Int. J. Engine Res.*, 2020.
- [8] J. M. Luján, V. Dolz, J. Monsalve-Serrano, and M. A. Bernal Maldonado, “High-pressure exhaust gas recirculation line condensation model of an internal combustion diesel engine operating at cold conditions,” *Int. J. Engine Res.*, 2019.
- [9] J. Galindo, R. Navarro, D. Tarí, and F. Moya, “Development of an experimental test bench and a psychrometric model for assessing condensation on a low-pressure exhaust gas recirculation cooler,” *Int. J. Engine Res.*, 2020.
- [10] J. Galindo, V. Dolz, J. Monsalve-Serrano, M. A. Bernal Maldonado, and L. Odillard, “Advantages of using a cooler bypass in the low-pressure exhaust gas recirculation line of a compression ignition diesel engine operating at cold conditions,” *Int. J. Engine Res.*, p. 1468087420914725, Apr. 2020.
- [11] A. J. Torregrosa, A. Broatch, P. and Olmeda, and C. Romero, “Assessment of the Influence of Different Cooling System Configurations on Engine Warm-up, Emissions and Fuel Consumption,” *Int. J. Automot. Technol.*, vol. 9, no. 2, pp. 447–458, 2008.
- [12] J. Manuel Luján, B. Pla, P. Bares, and V. Pandey, “Adaptive calibration of Diesel engine injection for minimising fuel consumption with constrained NOx emissions in actual driving missions,” *Int. J. Engine Res.*, 2020.
- [13] K. R. Vos, G. M. Shaver, A. K. Ramesh, and J. McCarthy, “Impact of Cylinder Deactivation and Cylinder Cutout via Flexible Valve Actuation on

- Fuel Efficient Aftertreatment Thermal Management at Curb Idle,” *Front. Mech. Eng.*, vol. 5, no. August, pp. 1–16, 2019.
- [14] F. J. Arnau, J. Martín, B. Pla, and Á. Auñón, “Diesel engine optimization and exhaust thermal management by means of variable valve train strategies,” *Int. J. Engine Res.*, 2020.
- [15] K. R. Vos, G. M. Shaver, M. C. Joshi, A. K. Ramesh, and J. McCarthy, “Strategies for using valvetrain flexibility instead of exhaust manifold pressure modulation for diesel engine gas exchange and thermal management control,” *Int. J. Engine Res.*, 2019.
- [16] D. B. Gosala, G. M. Shaver, J. E. McCarthy, and T. P. Lutz, “Fuel-efficient thermal management in diesel engines via valvetrain-enabled cylinder ventilation strategies,” *Int. J. Engine Res.*, 2019.
- [17] D. B. Gosala *et al.*, “Cylinder deactivation during dynamic diesel engine operation,” *Int. J. Engine Res.*, vol. 18, no. 10, pp. 991–1004, 2017.
- [18] A. K. Ramesh *et al.*, “Cylinder Deactivation for Increased Engine Efficiency and Aftertreatment Thermal Management in Diesel Engines,” *SAE Tech. Pap.*, vol. 2018-April, pp. 1–10, 2018.
- [19] J. McCarthy, “Cylinder deactivation improves Diesel aftertreatment and fuel economy for commercial vehicles,” *Bargende M., Reuss HC., Wiedemann J. 17. Int. Stuttgarter Symp. Proceedings.*, pp. 9–10, 2017.
- [20] C. M. Allen, M. C. Joshi, D. B. Gosala, G. M. Shaver, L. Farrell, and J. McCarthy, “Experimental assessment of diesel engine cylinder deactivation performance during low-load transient operations,” *Int. J. Engine Res.*,

2019.

- [21] J. P. Zammit, M. J. McGhee, P. J. Shayler, and I. Pegg, *Benefits of cylinder deactivation on a diesel engine and restrictions due to low boost*. Woodhead Publishing Limited, 2013.
- [22] A. V. Gritsenko, K. V. Glemba, and A. A. Petelin, "A study of the environmental qualities of diesel engines and their efficiency when a portion of their cylinders are deactivated in small-load modes," *J. King Saud Univ. - Eng. Sci.*, no. xxxx, pp. 1–10, 2019.
- [23] P. Mock, J. Kühlwein, U. Tietge, V. Franco, A. Bandivadekar, and J. German, "The WLTP: How a new test procedure for cars will affect fuel consumption values in the EU," *ICCT White Pap.*, vol. 2014, no. 9, pp. 1–20, 2014.
- [24] V. Macián, J. M. Luján, H. Climent, J. Miguel-García, S. Guilain, and R. Boubennec, "Cylinder-to-cylinder high-pressure exhaust gas recirculation dispersion effect on opacity and NO_x emissions in a diesel automotive engine," *Int. J. Engine Res.*, 2020.
- [25] J. Galindo, H. Climent, R. Navarro, and G. García-Olivas, "Assessment of the numerical and experimental methodology to predict EGR cylinder-to-cylinder dispersion and pollutant emissions," *Int. J. Engine Res.*, p. 1468087420972544, Dec. 2020.
- [26] P. Piqueras, A. García, J. Monsalve-Serrano, and M. J. Ruiz, "Performance of a diesel oxidation catalyst under diesel-gasoline reactivity controlled compression ignition combustion conditions," *Energy Convers. Manag.*,

vol. 196, no. May, pp. 18–31, 2019.

- [27] J. R. Serrano, P. Piqueras, E. J. Sanchis, and B. Diesel, “A modelling tool for engine and exhaust aftertreatment performance analysis in altitude operation,” *Results Eng.*, vol. 4, no. August, p. 100054, 2019.