

Document downloaded from:

<http://hdl.handle.net/10251/50771>

This paper must be cited as:

Camba, J.; Contero González, MR.; Johnson, M.; Company, P. (2014). Extended 3D annotations as a new mechanism to explicitly communicate geometric design intent and increase CAD model reusability. *Computer-Aided Design*. 57:61-72.  
doi:10.1016/j.cad.2014.07.001.



The final publication is available at

<http://dx.doi.org/10.1016/j.cad.2014.07.001>

Copyright Elsevier

**Contribution:**

Camba, J., Contero, M., Johnson, M., & Company, P. (2014). Extended 3D annotations as a new mechanism to explicitly communicate geometric design intent and increase CAD model reusability. *Computer-Aided Design*, 57, 61-73.

Elsevier has the exclusive, sole, permanent, world-wide, transferable, sub-licensable and unlimited right to reproduce, publish, distribute, transmit, make available or otherwise communicate to the public, translate, publicly perform, archive, store, lease or lend and sell the Contribution or parts thereof individually or together with other works in any language, in all revisions and versions (including soft cover, book club and collected editions, anthologies, advance printing, reprints or print to order, microfilm editions, audiograms and videograms), in all forms and media of expression including in electronic form (including offline and online use, push or pull technologies, use in databases and networks for display, print and storing on any and all stationary or portable end-user devices, e.g. text readers, audio, video or interactive devices, and for use in multimedia or interactive versions as well as for the display or transmission of the Contribution or parts thereof in data networks or search engines), in whole, in part or in abridged form, in each case as now known or developed in the future, including the right to grant further time-limited or permanent rights.

The final publication is available at Elsevier via:

[doi:10.1016/j.cad.2014.07.001](https://doi.org/10.1016/j.cad.2014.07.001)

# Extended 3D Annotations as a New Mechanism to Explicitly Communicate Geometric Design Intent and Increase CAD Model Reusability

Jorge Camba<sup>a</sup>, Manuel Contero<sup>b</sup>, Michael Johnson<sup>a</sup>, Pedro Company<sup>c</sup>

<sup>a</sup>Texas A&M University, College Station, TX

<sup>b</sup>Universitat Politècnica de València, Valencia, Spain

<sup>c</sup>Universitat Jaume I, Castellón, Spain

## Abstract

A successful implementation of the Model-Based Enterprise concept (MBE) requires maximizing the potential benefits of annotated 3D models. The foundations of the MBE model are established by digital product definition data practices, which are currently regulated by standards such as ASME Y14.41-2003 and ISO 16792:2006. At the center of the MBE concept is the notion of CAD model reusability, which relies on the idea that 3D CAD models can be reused both throughout the entire product lifecycle and as a starting point for future development of new products. In this context, a critical aspect of CAD model reuse is the proper identification and understanding of the geometric design intent that is usually expressed implicitly within the CAD model.

In this work, we present a method to communicate geometric design intent explicitly by overloading and extending the scope of the current annotation instruments available in the MBE approach. We propose a new broader type of model annotation that we call “extended annotation,” where design information is represented both internally within the 3D model and externally, on a separate repository. This structure naturally demands additional mechanisms to support the interaction of users with the information. In order to manage the information stored in these extended annotations effectively, we implemented an annotation manager that automatically synchronizes the dual representation of the annotations. To reduce the visual clutter in the 3D model, the software provides powerful filtering, editing, and visualization capabilities, giving users complete control of the information stored in the model. Finally, a study was conducted with 60 participants to evaluate the performance of the proposed model and the usability of the annotation manager. Results show a statistically significant benefit of using the extended annotation system, suggesting the use of this model as a valuable approach to improve design intent communication.

*Keywords:* 3D annotations, design intent, CAD model reusability, model-based enterprise.

## 1. Introduction

In the context of a highly competitive globalized market, the move towards a Model-Based Enterprise (MBE) presents a significant opportunity for increased efficiency in product development, as stated by Frechette [1]. In the MBE, a Computer-Aided Design (CAD) model is created and reused by various product commercialization functions throughout the organization. Historically, CAD models have been associated with improved quality, reduced development time, and improved communication [2]. When these CAD models are used in concert with Product Data Management (PDM) systems, they allow for greater benefits [3] and facilitate the distributed development that is possible in the MBE [4]. All these benefits are predicated on the assumption that the CAD model is reusable; i.e., it is readily understood and easily altered by others. This is often not the case.

For a CAD model to be easily altered, the person altering the model has to understand its “design intent” [5, 6]. “Design intent” is the reasoning behind decisions related to particular design objects [7, 8]. If the “design intent” is not appropriately captured in the model, it may become difficult to alter [9]. Given that one of the initial “promises” of CAD was the ability to store and easily alter existing models [10], the fact that models are often remodeled from scratch is somewhat of a “paradox” [11]. This is often due to the lack of explicit information about “design intent” in models created by others [12]. One way to provide information related to “design intent” is through the use of 3D annotations. Annotations added to 3D CAD models have been shown to reduce the amount of time required to make alterations to these models [13, 14]. However, as model complexity increases, a way to manage and interrogate these annotations is needed. This work presents a new annotation structure and assesses a novel 3D annotation manager software tool. Promising initial evaluation results support the feasibility of this system as a method to improve CAD model reuse.

Two important characteristics of any system aimed at improving CAD model reuse and alteration are usability and efficacy. In terms of usability, authors Drury et al., [15] listed some of the more cited usability rules (e.g., be consistent) according to Shneiderman and Plaisant [16]; heuristics (e.g., make system status visible) based on Nielsen and Mack’s work [17]; and principles (e.g., provide feedback) according to Norman [18], for human and computer interaction. In our work, usability is assessed by using an adapted version of the questionnaire developed by Chin et al. [19]. The efficacy of our system is assessed in a similar manner to the work by Lenne et al. [20] by determining the time required for participants to find the correct answer to design questions both with and without the annotation manager system.



Both ASME Y14.41 and ISO 16792 set guidelines for the logical association of product information to geometric elements, as seen in Fig. 1. In an attempt to mitigate the transition from 2D drawings to 3D models, the standards support two methods of product definition: model-only, and model and drawing in digital format, distinguishing between annotations defined as “dimension, tolerance, note, text, or symbol visible without any manual or external manipulation” and attributes defined as “dimension, tolerance, note, text, or symbol required to complete the product definition or model feature of the product that is not visible but available upon querying the model.” In this paper, we focus exclusively on product information linked to models. It has been suggested that properly annotated 3D models can eliminate a significant part of the cost of creating traditional 2D drawings.

The goal of both ASME Y14.41 and ISO 16792 is to make annotated models comprehensive and reusable by providing specific guidelines to distribute dimensions and tolerances on orthogonal planes. This mechanism mimics the dimensioning rules for 2D drawings in a 3D environment. However, 3D models can easily become cluttered, even with a small number of annotations and a carefully arranged layout. The example shown in Fig. 1 illustrates this concept (in spite of being a static black and white image with no user interaction). It becomes evident that practical management of annotations is a critical issue to provide an effective and efficient implementation of the model based definition approach. Although neither ASME nor ISO standards provide explicit information about using and managing free textual annotations (which we intend to use to express design intent), SASIG standard recommends the use of groups, layers, or links to views or sections of the geometry to make the model readable. As this standard states, “turning on all annotations in a complex model may make viewing the annotation and/or model very difficult” [29]. Because we anticipate a large volume of information included in the annotations when used to deliver design intent, especially when working with complex models, we propose a non-structured mechanism (where a manual arrangement of annotation planes is not required) based on standard annotations and an integrated annotation interface to enhance their functionality and suitability to carry this type of information. From a usability point of view, the previous considerations are essential aspects for a successful implementation of our proposed annotation model.

### *2.3. Product data quality context*

One of the most important contributions of modern CAD to accelerate the product development process is the ability to reuse and make alterations to existing models in an efficient and relatively easy manner. According to the linguistic model proposed by Contero et al. [30], three levels of CAD quality can be distinguished, the third of which, the semantic/pragmatic level, considers the capability of the CAD model for reuse and modification. Making changes or reusing a particular CAD model may be simple, difficult, or impossible, depending on the semantics associated to the modeling procedure chosen by the original creator.

To achieve the full benefit provided by 3D CAD models, users that interact with them should understand how and why the component was created and designed in a specific way; namely, they must understand its design intent. In this work, “design intent” or “geometric modeling intent” will be used distinctly to express the reasons that motivate a designer to perform some specific CAD modeling actions. It also expresses the manner in which the designer expects the geometric model to behave when it is modified [14]. Design intent becomes critical in situations where the user altering a model is not the original creator, such as in collaborative design scenarios. Explicit communication of design intent is especially valuable for the reutilization of complex 3D CAD models, in which important amounts of modeling time are invested.

Annotations can play an important role in identifying best modeling practices, which can be of great importance for avoiding modeling errors. According to the classification of CAD modeling errors proposed by Yan & Han [31], three primary types can be identified. The first type is related to topological and geometric inaccuracies, such as discontinuities, small and void faces, and self-intersection problems. Currently, these problems are well covered by standards such as VDA 4955/4.1 [32] and SASIG PDQ 2.1 [33]. These problems can be termed as intrinsic problems (associated to morphological quality, according to [30]). The second type of problems is related to the product data exchange process, i.e. when models are converted to and from different formats. These errors are usually due to mismatches in the numerical inaccuracies of the geometric kernels upon which CAD systems are built. We hypothesize that this second type of problems may also be linked to the syntactical quality suggested by Contero et al. [30]. These two types of problems can be termed extrinsic which, along with intrinsic problems, are out of the scope of our study.

However, there is a third group of problems that are caused by users as a result of poor or incorrect practices with the CAD system (i.e. semantic quality [30]). According to Yan & Han [31], a third to a half of all quality problems arise either from poor design skills or from the inexperience of designers. In this case, two complimentary strategies can be applied. First, according to Mandorli and Otto [11], current education should provide more strategic knowledge and understanding to enable students to use CAD systems as knowledge-intensive design and communication tools to properly develop and convey design intent. Second, 3D annotations carrying hints, warnings, and indications to specific modeling questions can be useful to help users understand the reasons behind complex modeling decisions. Additionally, making this information available outside the model easily allows the use of external information systems to manage and analyze the design knowledge contained within the extended annotations. A new contribution to the second strategy is studied next.

#### 2.4. Design intent communication and model reuse

As indicated by Iyer et al. [59], citing Ullman [60], many design problems require the application of previous knowledge and the redesign of existing products. According to an industry research report by the Aberdeen Group [4], significant time and cost savings were achieved when companies reused design elements. Furthermore, all firms participating in the study report the reuse of existing designs at some level, but the top performers intentionally dedicate resources and deploy methods and technologies to capitalize on reusability. However, to guarantee effective CAD reusability it is necessary that users working with a CAD model understand the reasons and rationale behind the modeling decisions. They need to know how and why the model was created in a specific manner, i.e., they need to understand its design intent.

It is hard to find a precise definition of design intent, since the term can be interpreted in slightly different ways [34-36]. After an exhaustive literature review to identify common elements, authors Iyer and Mills [7] proposed their own definition, which is generally widely accepted: "Design intent contained in legacy CAD is the insight into the design variables (design objectives, constraints, alternatives, evolution, guidelines, manufacturing instructions and standards) implicit in the structural, semantic and practical relationships between the geometric, material, dimensional and textual entities present in the CAD representation." [7]. The importance of design intent and the advantages of an explicit representation were summarized by Pena-Mora et al. [37]:

- Changes in complex projects require certain design decisions to be modified during the development process. When the justifications defined during the initial stages are lost, they need to be recreated, which has a negative impact on project costs and development times. The ability to store, process, and retrieve this information can significantly improve productivity.
- When design intent information is represented explicitly and is easily available for review, the overall quality of the product increases.
- Explicit representation of design intent leads to a more intelligent use of resources and knowledge.
- Efficient communication of design intent is essential for integrating solutions and transferring design knowledge.

To benefit from the functionality provided by modern CAD systems, to quickly and efficiently modify existing designs, users interacting with the model must understand the reasons behind the modeling process. In other words, the design intent of the model must be appropriately captured and understood by the person making the changes. [5, 6]. Despite major advances in CAD technology, models are difficult, or impossible, to alter when design intent information is lost or not communicated properly [12].

Some considerations to communicate design intent effectively include how this type of information can be captured, represented, managed, processed, and stored. These are active areas of research [7] and still poorly addressed by current industrial tools [38]. Although some success has been reported using semi-automated tools [38-41], the task of capturing design intent cannot be completely automated [42], and thus requires designers to be actively involved throughout the entire process. Unfortunately, it has been shown that designers are often reluctant to spend time adding additional information to their models [43]. Therefore, any tools to support interaction with design intent information must be easy to use, intuitive, and integrated with existing solutions [44].

Design knowledge is a broad term that can be understood at different abstraction levels throughout the design process. The diversity and complexity of knowledge involved in engineering design makes it difficult to capture and represent this information. The complex and highly dynamic nature of knowledge management has led to the development of various types of tools for various applications: knowledge sharing, expert systems, knowledge retrieval and query, etc. On an abstract level, for example, representation and manipulation of the model's function is a crucial issue during conceptual design, as indicated by Umeda et al. [45]. Because current CAD systems do not support functional design, the authors implemented a software tool called Function-Behavior-State (FBS) Modeler, which supports functional design during both the analytical and synthetic phases of conceptual design [45]. According to Gero [46], a representation framework with sufficient expressive power to capture the nature of the concepts is required for design. He proposed a knowledge representation schema based on design prototypes to separate knowledge from computational processes. The use of this representation provides a translation between design syntax and semantics [46]. Other examples of knowledge capture systems include the Market Driven Design System [47], used to capture and collect market information within a product model using fuzzy inference.

How to represent design knowledge effectively is a fundamental issue in knowledge management, and representation models and formats can vary greatly as they support different design activities. Despite the variety of methodologies and systems available, there are still barriers in terms of practical implementations in industrial environments that need to be overcome: information confidentiality, lack of adequate training in the use of knowledge management, language, affordability, cost, technology levels, etc. [48]. The most sophisticated approaches often involve the use of complex external systems, such as Compendium [42] and DR editor (DRed) [38] (both based on the concept of Issue based Information System or IBIS [49]), and rely heavily on human intervention, especially for interpreting and entering

information into the system. Other approaches include argumentation-based models such as Decision Representation Language (DRL) [50], which was further extended by Software Engineering Using Design RATIONale (SEURAT) [51], and the Question, Option and Criteria (QOC) technique which emphasizes discussions of alternatives regarding artifact features [50]. Most representation models are related to specific domains. For example, functional representations focus on describing how the device works [52]. A Rationale Construction Framework (RCF) was also suggested to capture rationale information by monitoring designers' interaction with a CAD system [41]. Although progress has been made, the most advanced techniques and algorithms for data mining and design document processing rely heavily on textual representation of design knowledge [53].

In this paper, we specifically focus on geometric design intent information, i.e. the type of knowledge directly related to the CAD model's geometry information (explanations of why a CAD model is modeled the way it is or why certain modeling steps have been performed). In this context, our goal is to provide a simple yet efficient mechanism that can be fully integrated within the CAD environment and allows designers to add relevant geometric information to a 3D model efficiently while maintaining a repository of design intent information to help designers understand design modeling know-how, and also facilitate the reuse of models.

In the area of software development, engineers use comments in source code to support software maintenance, modifications, and reusability. Similar benefits are likely in product design scenarios. To accomplish this, we have enhanced the functionality of standard 3D annotations and made them carriers of geometric design knowledge. Although in engineering design annotations have traditionally been used to complement engineering drawings, they can play a fundamental role in the cognitive synchronization between designers and as interface elements to mediate interactions, as stated by authors Boujut and Dugdale [54]. However, as CAD models become more complex and comprehensive, it becomes necessary to redefine the traditional structure of model-based annotations and transform them into model-based design annotations. Although our approach relies heavily on the textual representation of information, we have incorporated support for other types of design knowledge such as hyperlinks, sketches, graphical information, external documents, etc). All these elements can be connected to the CAD model and presented to the user within the CAD environment.

### 3. Extended annotations for expressing geometric modeling design intent

The annotation system developed for this study involves the addition of new structures and connections to the 3D annotated model defined by the SASIG standard [29] (see Fig. 2).

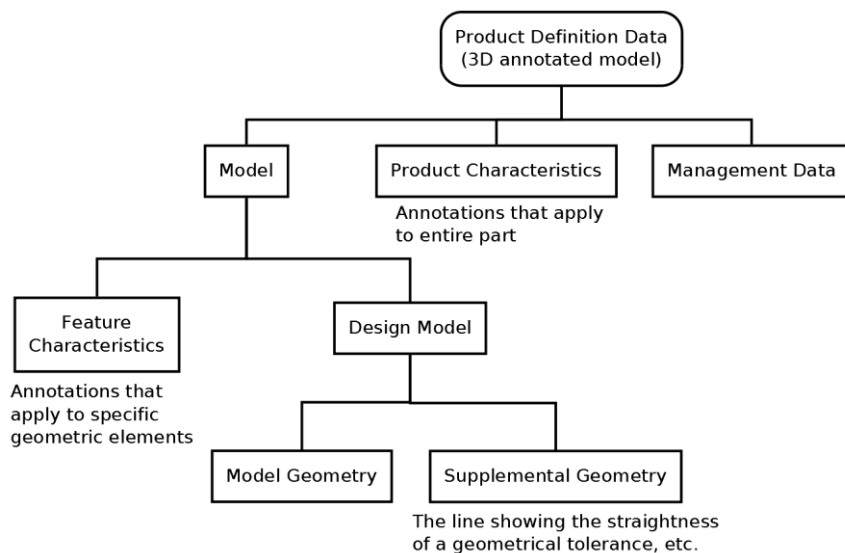

Fig. 2. Information configuration of a 3D annotated model [29].

One of the main contributions of this paper is the introduction of extended annotations as bidirectional structures capable of carrying geometric design intent information both within 3D models and in an external repository. These structures are natural extensions to the annotation mechanisms defined by current standards and implemented by modern CAD packages. Because of the limitations of the existing annotations structures available in PMI modules (visualization and interaction mechanisms such as filtering and searching are non-existent) we provide a more flexible mechanism based on a dual representation. An additional contribution is an annotation manager that works as an automatic agent in charge of managing and synchronizing the dual representation of the annotations. Our proposed model is illustrated in Fig. 3. The nodes shown in gray represent information stored outside the 3D model.

Using the classification defined by Ding et al. [55] (based on how data is stored), we can explain that our extended annotations are designed to combine the strengths of both “in-line” (annotations inserted in the CAD model) and “stand-off” (annotations stored separately in an external repository) representations. The advantages and disadvantages of both methods are listed in Table 1, which is a modified version of the table prepared by [55].

**Table 1.** Mark-up strategies (\*new items added to the original list created by [55])

STRATEGY	ADVANTAGES	DISADVANTAGES
<i>In-line</i> (internal)	Easy implementation. Wide applications. * Full integration with the model (low maintenance). * Efficiency in terms of processing and manipulation. * Already supported by most CAD systems.	Original document changed. Difficulty for multiple independent sets of markup. * Difficult to share information in collaborative environments.
Stand-off (external)	Non-change of representation method used for the original object. Support of multiple independent sets of markup. Support of progressively information update (scalability). Capability of re-organization of information for different purposes and applications. * Easy distribution of information in collaborative environments and over the web. * Information can be processed and analyzed separately.	Difficulty of implementation. Problem of persistent references. Lack of robust maintenance method of references. * File maintenance.

By allowing “in-line” techniques, we ensure a simple integration of the extended annotation model within existing CAD packages. Designers can thus annotate 3D models using already familiar tools, instead of spending valuable time learning new separate systems. This strategy minimizes the annotation workload and benefits from the familiarity of the users with existing software, which is a crucial factor for a practical implementation of the model and the avoidance of the knowledge-acquisition bottleneck [44]. In our model, the “in-line” aspects of the annotation are accomplished by overloading the functionality of the Product and Manufacturing Information (PMI) modules available in modern CAD systems.

**EXTENDED ANNOTATION COMPONENTS**

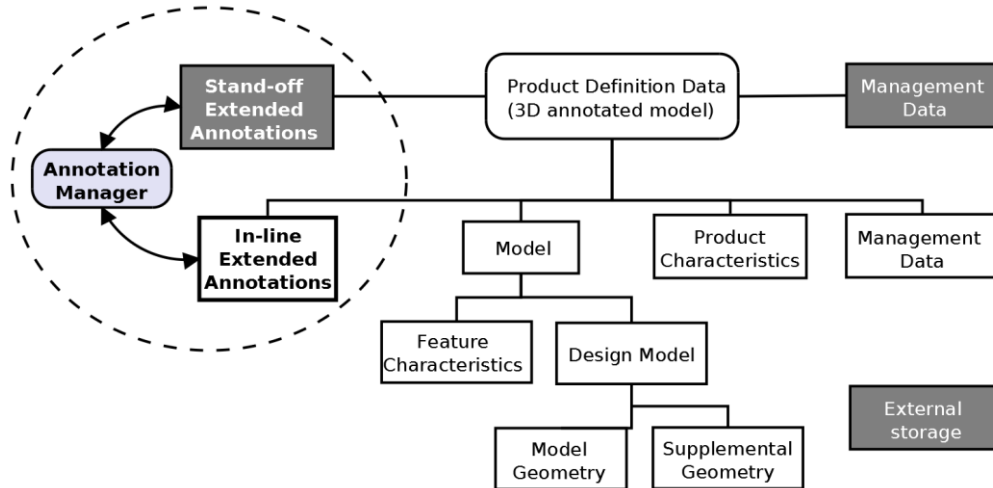

**Fig. 3.** Extended Annotation Model (Adapted From [29])

The “stand-off” characteristics of extended annotations facilitate and optimize the visualization, search, and filtering of information. The visualization and display of 3D annotations are essential factors to ensure the effectiveness of an annotated model in terms of communication of information. In fact, the use of groups, layers, and annotation views to improve the readability of the annotations is specifically encouraged by the SASIG standard [29], although no precise guidelines are provided regarding how this functionality should be implemented. At this point, basic perception principles and its application to visual representations must be reviewed. The visual management of the annotations



becomes especially relevant when the volume of the annotations in the 3D model grows to the point where it creates clutter and confusion (such as the model shown in Fig. 7), making the use of the annotated model impractical. The external representation of the extended annotation model along with the management capabilities offered by the annotation manager provides an automatic visualization framework for 3D annotations that frees the user from time-consuming tasks such as creating annotation views and organizing the information manually. It is based on visual search principles. Additionally, when the information is available outside the model, effective strategies can be developed to analyze the knowledge contained within the extended annotations.

### 3.1 Representation of extended annotations

In our model, 3D annotations are stored both internally within the CAD model, and externally. The internal representation of the annotation is managed directly by the PMI tools of the CAD system. The information includes the content of the annotation, the point of connection between the annotation and the aspect of the CAD model that is being annotated (typically, a face or a feature), and the identifier of the annotation element within the CAD file, used to uniquely identify the annotation and associate it with the corresponding external data.

An extended annotation is defined externally as a set of textual elements, such as:

$Extended\_annotation = \{ Internal\_ID, Type, Feature, Text, Creator, Date, [Additional\_Items] \}$  where:

- *Internal\_ID* is the unique identifier of the annotation element within the CAD model.
- *Type* is used to classify annotations into different categories, i.e. modeling annotations, manufacturing annotations, etc. It is intended for semantic searches.
- *Feature* is the specific geometric element or “form feature” of the CAD model that is being annotated.
- *Text* is the content of the annotation.
- *Creator and Date* represent the author of the annotation and the date of last modification.
- *Additional\_Items* is an optional field that can be used to include other type of information such as hyperlinks or references to external documents that may be relevant to a specific part of the 3D model.

```
<?xml version="1.0" encoding="utf-8"?>
<Annotations>
  <Part name="Model_1" path="C:\models\assembly\">
    <Annotation type="modeling" id="id1">
      <Feature>Revolve1</Feature>
      <Text>Modify fillet radius if angle changes</Text>
      <Creator>camba</Creator>
      <Date>7/20/2013</Date>
    </Annotation>
  </Part>
  <Part name="Bracket" path="C:\models\assembly\">
    <Annotation type="modeling" id="id1">
      <Feature>Fillet1</Feature>
      <Text>Modify fillet radius if body angle changes</Text>
      <Creator>contero</Creator>
      <Date>7/15/2013</Date>
    </Annotation>
    <Annotation type="design" id="id2">
      <Feature>Extrude2</Feature>
      <Text>Ensure a minimum angle of 20 degrees</Text>
      <Creator>camba</Creator>
      <Date>7/25/2013</Date>
    </Annotation>
  </Part>
</Annotations>
```

Fig. 4. Structure of XML file

In terms of implementation, different types of external storage can be used to manage the external representation of the annotations, such as relational databases or XML files. For our prototype, we originally selected the latter, where every annotation corresponds to a node in an XML tree, as shown in Fig. 4. The textual data format and structured syntax of XML makes this language a suitable option for representing and accessing the specific elements of the extended annotations in an effective manner.

A single XML file is used to store extended annotations of multiple 3D models that are related functionally, such as components of the same assembly, or models of the same family, such as different versions or variations of a particular CAD model. The name of the 3D model and its file location are stored as attributes of the model node. To facilitate filtering and searching tasks, the child nodes “ID” and “type” can be converted to attributes of the corresponding parent node. The structure of the XML file is shown in Fig. 5.

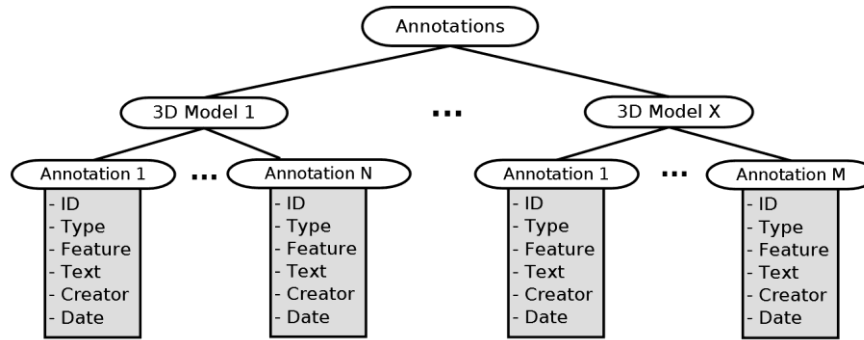

Fig. 5. External XML representation of extended annotations

#### 4. Annotation Manager

The annotation manager is a software component that keeps the internal and external representations of the model annotations synchronized, and provides a graphical user interface to interact with the information included in the extended annotations. In our model, the annotation manager is envisioned as a fully integrated module of a traditional CAD system, possibly as part of the Product and Manufacturing Information (PMI) toolset.

3D annotations have been supported by CAD packages for years and the adoption of 3D annotation practices (specifically Geometric Dimensioning and Tolerancing, abbreviated “GD&T”) has increased since the appearance of Model-Based Definition standards, such as ASME Y14.41-2003 and ISO 16792:2006. The creation and direct manipulation of the annotations (move, edit, delete, etc) within the 3D model, as well as the definition and selection of annotation planes, and visibility control are tasks that can be handled directly by standard PMI modules. Therefore, there is no need to duplicate this functionality in the annotation manager. Instead, the focus of the tool will be on the synchronization, filtering, grouping, searching, and efficient visualization of information.

For this study, our team developed a software prototype of the proposed annotation manager. The application was implemented as a SolidWorks® module, a popular CAD package. We selected this particular tool because it was easily available to the authors and because of the previous experience the authors had with its Application Programming Interface (API).

The synchronization of the internal annotations with the external XML file is handled by a background process that is triggered every time a new model annotation is created, modified, or deleted within the CAD package, or when the model is saved. No action is required from the user to maintain the information updated and synchronized. Likewise, internal annotations in the CAD model are automatically updated when changes are made to the external representations using the annotation manager, ensuring the bi-directionality of the extended annotation model automatically. This background process also handles annotation change propagation to ensure consistency of changes by maintaining the most updated version of the annotations in both annotation structures. In case of inconsistencies, the process evaluates the information from the model with the information stored externally and prompts the user on how to proceed. Changes can be synchronized from the model to the external repository, from the external repository to the model, or they can be combined (updating both the external repository and the model) by comparing the annotations and maintaining only the most recent version in both places.

Due to the evolving nature of product development, models undergo constant change, which often causes the associated information not to be properly updated. As geometry changes, poor or incomplete documentation of particular design operations are common occurrences. Although the extended annotation structures we propose are not tightly connected with design features, we do provide a mechanism to manage design changes and track annotation information. We address this issue by incorporating the functionality of the annotation manager into a Product Lifecycle Management (PLM) system, where we developed an annotation history module that maintains a record of changes in the annotations and justifications related to design intent. The details of this module and the integration scheme have been published in a separate study [56].

The annotation history module provides an automatic mechanism to manage information changes about particular design decisions. It is comprised of an additional repository in the PLM database that stores obsolete versions of the annotations, and a new event handler that records the old annotation and the specific action that was triggered (e.g. the content was altered, the annotation was reattached to a new feature, the annotation was deleted, etc.) every time a modification is detected and before the new annotation record is updated in the original file. Dates and user information are also recorded, providing an audit trail that can be used to understand the evolution of a model, process historical data, analyze actions of the users involved in particular design decisions, and identify design problems [56]. Access to the annotation history is provided by the annotation manager available from the CAD system, so users can track all changes performed and have the information readily available. In addition, historical annotation data could also be made available via a web-based interface. This would allow,



are ultimately the user's responsibility, many designers often choose not to benefit from annotation tools because of the additional effort involved in this task. Alternatively, our study shows better acceptance of the unstructured nature of our approach as long as filtering and searching mechanisms are available. In our experiment, we showed that users that interact with 3D models with no visualization or filtering tools perform significantly worse than users with access to annotation management mechanisms, such as the proposed annotation manager [57].

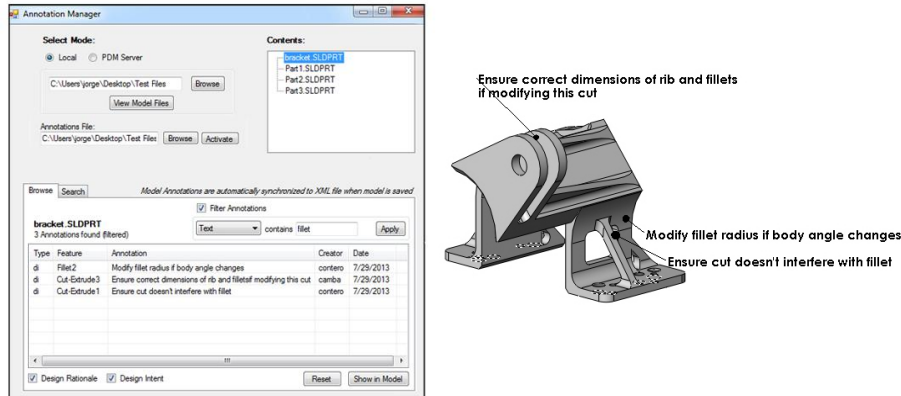

Fig. 8. Annotations filtered by keyword

## 5. Integration with Product Lifecycle Management Systems

As an alternative to the original XML representation, we describe the architecture of a second implementation using an external database, and how this architecture is integrated within a Product Lifecycle Management (PLM) system, so our system can be used more reliably in collaborative environments. The details of this implementation have been presented in our recent work [56]. The availability of annotation information in a database facilitates the use of more powerful management, filtering, and searching mechanisms. This database implementation also facilitates support for other types of design knowledge such as hyperlinks, sketches, graphical information, external documents, etc). The document management aspect of this functionality can be directly handled by the database system, whereas the links between external elements and annotations within the CAD model are managed by the annotation manager. We have implemented a browser-style document viewer that is fully integrated with our annotation manager, so documents and images related to the CAD model can be examined without leaving the CAD environment. In addition, searches and data mining techniques can be performed on external documents and immediately relate results to annotations and CAD models.

For our database implementation, we defined an annotation table where every child node of the original annotation node described in the XML file becomes a field in the table. An additional field (model identifier) keeps a reference to the specific version of the 3D model the annotation is linked to. The annotation database can now be included as a new component of a Product Data Management (PDM) module in a PLM system. The PDM is the system that manages shared 3D CAD models (with the corresponding internal annotations, in our case) and the associated documentation, acting both as a version control system and file vault. The synchronization component of our annotation manager is connected the PDM module and accessible from the CAD application. The synchronization mechanisms are transparent to the user, as they are automatically launched in the background when an alteration is detected in the model. When users work locally, (disconnected from the annotations database) and connect to the PLM system after a series of changes have been made to the model, the annotation manager compares the information from the model with the information from the PLM database and prompts the user on how to proceed regarding the propagation of changes. The architecture of this version of our system is illustrated in Fig. 9.

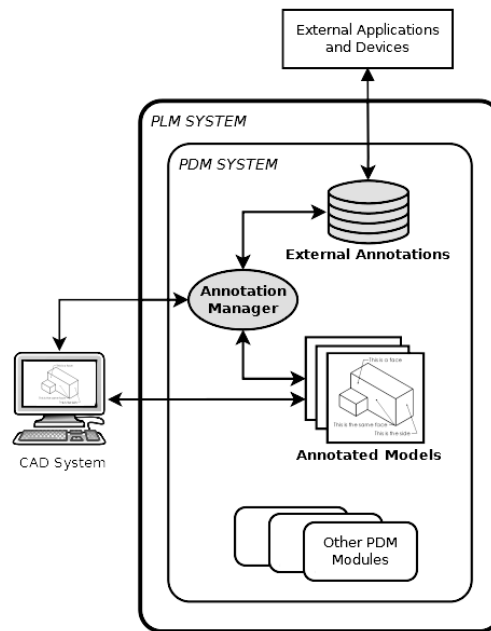

Fig. 9. System architecture (arrows represent information flow). Standard PLM modules have been omitted for clarity.

The availability of the annotations in the PLM database provides a method to feed and share information with external applications, which can be valuable in a variety of situations. For example, both content and quality of the annotations can be studied as well as the interactions between users, with the purpose of determining what makes annotations effective in design environments. Knowledge derived from annotations can ultimately be used to define sets of best modeling practices or as indicators of quality. In addition, the integration of our system with a PLM solution opens new opportunities for collaborative design. In this context, our team added video conferencing functionality to the annotation manager. The video conferencing module connects users in a collaborative scenario via the extended annotation structures [58]. This functionality is especially important in situations where multiple designers annotate the same model extensively. In these cases, certain annotations may not be clear, requiring further clarification by the annotators. We propose a direct link between model annotations and communication tool, so the annotator information is available “per annotation.” Therefore, users that interact with an annotated model can select an annotation, retrieve the contact information of the annotator from the PLM system, and make a video call or share the screen with that particular user to ask questions or request additional information. The complete workflow happens within the CAD environment.

From the perspective of the communication module, the scope of the PLM system is extended to manage contact information of the participants (model creators, users of models created by others, and annotators), which is linked to the CAD files of a particular project. This information includes the workstations’ IP addresses and ports, which allows the module to identify users when establishing a call. The system architecture with the communications module is shown in Fig. 10. Dashed lines indicate traffic between the CAD application and the PDM system (to synchronize CAD files, update files, etc). Solid lines represent data flow between the annotation manager and the communications module. When a CAD model is loaded in a workstation, the module automatically connects to the PLM system and requests the contact information of other users involved. The information is stored as a new table in a database managed by the PLM system and displayed in the user’s screen, directly within the CAD interface. Commands are available to establish video calls and shared screen sessions with the selected participants. The technical details of the implementation of the video conferencing module are discussed in [58].

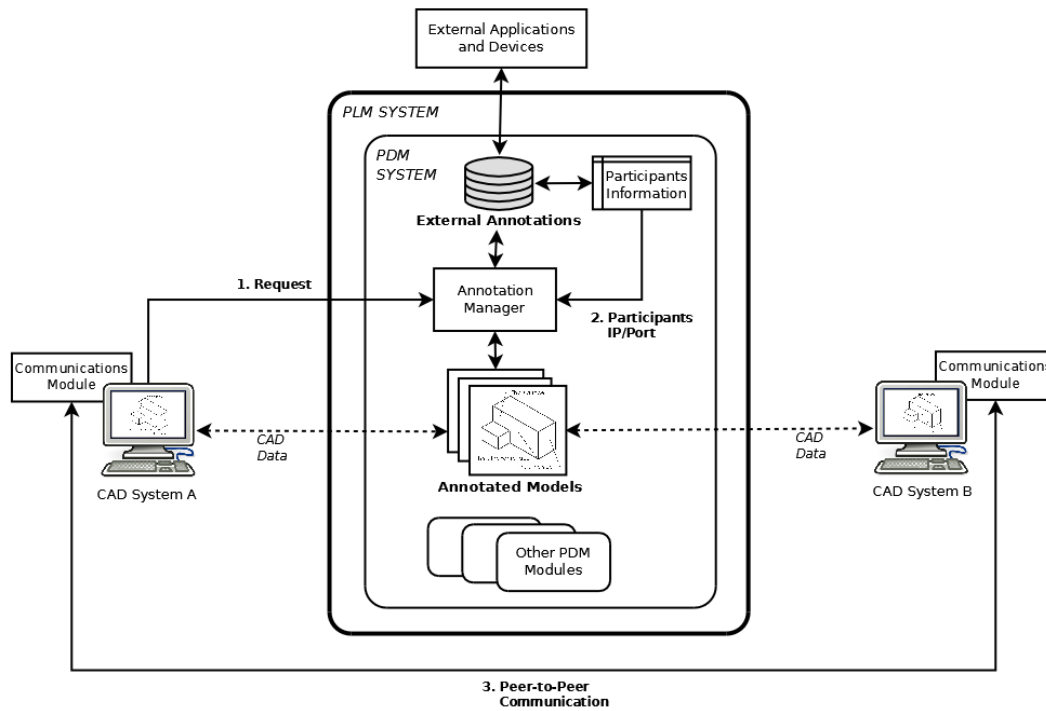

Fig. 10. System architecture with communications module

## 6. Evaluation

A study was conducted to determine the impact of the annotation manager in performing tasks that require finding information in an annotated 3D model. In addition, a pilot usability test was also performed to assess the application's user interface. Because of the difficulty of evaluating an experimental tool in a real industrial environment (personnel availability, daily workload and deadlines of designers, integration risks, and time involved in familiarize users with the new system, etc), we decided to test our system in an academic setting. A total of 60 volunteers (students and faculty) participated in annotation manager information study and evaluated the tool's usability. All participants had previous technical training in engineering design graphics and with SolidWorks® and/or other CAD packages.

The experiments were conducted in a computer laboratory environment where participants were called one at a time to complete the exercises. This procedure helped prevent involuntary peer pressure on participants that took longer times to finish. Participants were equipped with a computer with two monitors: the first one showing the CAD package (SolidWorks®) with the annotated 3D model required for the exercises, and the second showing the annotation manager prototype. A total of 30 annotations were included in the model. All dimensions were made visible as well.

Proper feature naming conventions were not considered in the model used for this study. As shown in Fig. 6 and Fig. 7, features show default names with sequential number indicating the order of creation. Although proper naming practices can add a certain level of expressive value to the model, its relevance in this study is limited. Due to the nature of the design intent information used in our annotations (e.g. "Ensure a minimum angle of 20 degrees" or "Thickness increased after FEA results", etc.), the use of representative feature names is not practical as they cannot efficiently communicate the message. Therefore, their effect in our experiment is negligible.

Two sets of two exercises were defined by our team. The objective of the exercises in the first set is to find a specific model annotation with the answer to a question. The exercises in the second set are design problems where certain modifications need to be performed to the 3D model. These alterations intentionally cause rebuild errors or unwanted effects in other parts of the model, which can be resolved by taking different approaches. Five possible answers (in multiple-choice format) were presented to the participants, who were asked to select the correct answer based on the annotations defined in the model.

All participants answered all four questions, but were only asked to use the annotation manager for one question from the first group and one question from the second group. As a result, all participants contributed to both the control and experimental groups. All the questions used in the study are available in the Appendix. Initially, participants were given a brief presentation with a demonstration of the software prototype, and were allowed a few minutes to familiarize themselves with the 3D model and the software. Questions were given one at a time, and participants' activities were timed (starting from the time they received the question) to determine how long they required to find the correct answer.

A t-test was used to examine the difference in the time required to complete the four design questions with and without the annotation manager. For each question, the mean time required to answer the question was significantly less with the aid of the extended annotation system than without. These results (see Table 2) show a statistically significant benefit of using the extended annotation system for all four questions.

Question	With ann. manager		Without ann. manager		<i>t</i>	<i>p</i>
	<i>n</i>	<i>M</i>	<i>n</i>	<i>M</i>		
#1	30	65.5	30	212.6	11.10	< 0.001
#2	30	72.5	30	131.3	12.91	< 0.001
#3	30	169.4	30	310.2	14.83	< 0.001
#4	30	370.9	30	663.1	15.16	< 0.001

**Table 2.** T-test comparison of time (s) required to answer questions (*n*: sample size, *M*: time in seconds)

As a second study, a psychometrically validated usability questionnaire adapted from [19] was distributed to the participants at the end of the session. A set of questions were presented using a numerical ten-point Likert scale. The questions were intended to evaluate the usability of the annotation manager and the user satisfaction levels with the tool. These levels are measured using the mean and standard deviation of the data obtained from the participants’ responses. The questions given to the participants as well as the statistical measures used to analyze the results are shown in Table 3. No responses were ranked below 5.

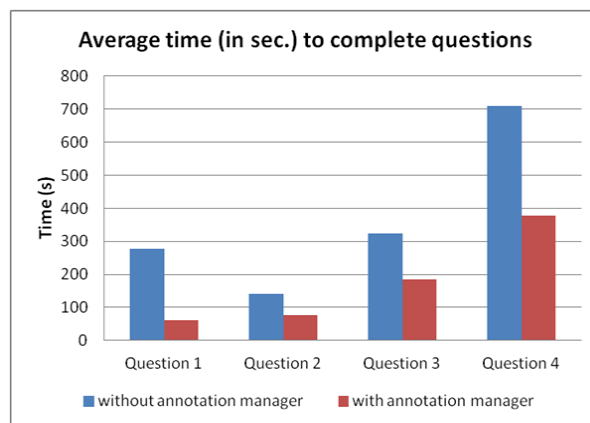

**Fig. 11.** Average time improvements with annotation manager

In general, the functionality of the annotation manager was well received, with most participants expressing positive reactions, acknowledging its value, and ranking the application highly in most areas. It is important to note the particularly high scores given to questions A2: “Usefulness and value of the application” and B3: “Highlighting of annotations on the 3D model simplifies tasks.” The positive evaluation results shown in Table 2 are especially relevant when viewed in combination with the significant improvement in terms of the time required to find information for completing a task, as reported above and illustrated in Fig. 11.

Observation of the participants’ behavior and their approaches to the problems presented confirms our initial assumption: visual clutter is an important problem when the user has to interact with an extensively annotated model. While organizing annotations in views is critical for regular 3D annotations (as suggested by the SASIG document [32]), implementing the extended annotation model is not practical without a tool like the annotation manager, as visual clutter would prevent exploiting all the benefits that the explicit communication of design intent represents for model alteration and reuse.

Question	Scale	Mean	Std. Dev.	
<i>Overall Reactions to the Software</i>				
A1	Overall experience with the software	0 (terrible) - 9 (wonderful)	7.03	0.99
A2	Usefulness and value of the application	0 (not useful or valuable) - 9 (very useful and valuable)	7.72	0.83
A3	Ease of Use	0 (difficult) - 9 (easy)	7.95	0.79
A4	Level of satisfaction with the software	0 (frustrating) - 9 (satisfying)	7.63	1.02
A5	Level of interest and motivation to use the software	0 (dull) - 9 (stimulating)	7.22	1.04
<i>Screen</i>				
B1	Organization of information on screen	0 (confusing) - 9 (very clear)	7.88	0.80
B2	Visualization of annotations in the application	0 (unclear & hard to read) - 9 (clear and easy to read)	8.15	0.82
B3	Highlighting of annotations on 3D simplifies tasks	0 (not at all) - 9 (very much)	8.52	0.57
<i>Terminology and System Information</i>				
C1	Use of terms throughout system	0 (inconsistent) - 9 (consistent)	8.12	0.67
C2	Messages on screen which prompt user for input	0 (confusing) - 9 (clear)	7.45	1.02
C3	Computer keeps you informed about what it is doing	0 (never) - 9 (always)	6.85	0.92
<i>Learning</i>				
D1	Learning to operate the system	0 (difficult) - 9 (easy)	8.43	0.59
D2	Exploring new features by trial and error	0 (difficult) - 9 (easy)	7.17	0.99
D3	Remembering names and use of commands	0 (difficult) - 9 (easy)	8.20	0.78
D4	Tasks can be performed in a straight-forward manner	0 (never) - 9 (always)	7.95	0.79
<i>System Capabilities</i>				
E1	System speed	0 (too slow) - 9 (fast)	8.18	0.83
E2	System reliability	0 (unreliable) - 9 (reliable)	7.83	0.98
E3	Correcting your mistakes	0 (difficult) - 9 (easy)	7.75	1.02

**Table 3.** User Satisfaction Questionnaire and Results

## 7. Conclusions and future work

As the Model-Based Engineering paradigm becomes more popular and 3D models continue to carry increasing amounts of design data, the need for methods and tools to support, manage, and present this information also increases. In addition, as models become more complex, there is also a need to capture and communicate geometric design intent in an explicit manner, so models can be reused easily. Although the appearance of standards for digital definition data practices such as ASME Y14.41-2003 and ISO 16792:2006 has formalized the way product information is presented in a 3D model, the use of annotation tools to communicate design knowledge remains relatively unexplored.

In our study, we have exposed the limitations of current annotation models; specifically, highlighting the limitations placed on users in light of numerous annotations. We have introduced a broader and more interactive structure and demonstrated the feasibility of this new model in terms of design intent communication. The preliminary studies conducted with our prototype reveal the value of the annotations as carriers of design information when proper managing, filtering, and visualization mechanisms are in place. This study showed a statistically significant benefit of using the extended annotation manager when answering questions related to CAD model design intent.

Our current prototype allows users to manually select the annotations to display, but only differentiates between two groups of information: selected annotations (highlighted) and unselected annotations. More sophisticated grouping strategies will be explored in the next version of the tool. First, we plan to further benefit from the capabilities of color to differentiate more than two groups by graying out visible annotations that are unrelated to the selected ones, thus creating three groups: selected, related, and nonrelated. This strategy is intended to support the user during visual searches. In heavily annotated models, other perceptual grouping strategies, such as size and patterns, can also be explored to assist users in browsing the related annotations.

The use of the proposed extended annotations encourages the definition of more comprehensive CAD models, where annotation information can be used as a resource for data analysis techniques. For example, different characteristics of the annotations can be analyzed, potentially inspiring techniques and quality metrics for improving CAD model reuse, or as a basis to collaboratively define sets of best design and modeling practices.

Further evaluation with larger samples is still pending. In addition, a more comprehensive analysis with a wider range of 3D models representing diverse design scenarios could provide new insights in terms of areas of application. We are interested in determining the effects of the extended annotation model in the overall product development process and estimating the impact of design intent annotations in CAD model quality.



## References

- [1] Frechette SP. Model Based Enterprise for Manufacturing. In: Proceedings of the 44th CIRP International Conference on Manufacturing Systems; 2011.
- [2] Baba Y, Nobeoka K. Towards Knowledge-Based Product Development: The 3D CAD Model of Knowledge Creation. *Research Policy* 1998;26(6):643-659.
- [3] Liu DT, Xu XW. A Review of Web-Based Product Data Management Systems. *Computers in Industry* 2001;44(3):251-262.
- [4] Caldwell B, Mocko GM. Product Data Management in Undergraduate Education. In: Proceeding of the ASME International Conference on Computers and Information in Engineering; 2008. p. 433-441.
- [5] Regli WC, Hu X, Atwood M, Sun W. A Survey of Design Rationale Systems: Approaches, Representation, Capture and Retrieval. *Engineering with Computers* 2000;16:209-235.
- [6] Karsenty L. An Empirical Evaluation of Design Rationale Documents. In: Proceedings of the SIGCHI Conference on Human Factors in Computing Systems; 1996. p. 150-156.
- [7] Iyer GR, Mills JJ. Design Intent in 2D CAD: Definition and Survey. *Computer-Aided Design and Applications* 2006;3(1-4):259-267
- [8] Henderson MR. Representing Functionality and Design Intent in Product Models. In: Proceedings on the second ACM Symposium on Solid modeling and Applications; 1993. p. 387-396.
- [9] Rodriguez J, Ridge J, Dickinson A, Whitwam R. CAD Training Using Interactive Computer Sessions. In: Proceedings of the ASEE Annual Conference and Exposition; 1998.
- [10] Liker JK, Fleischer M, Arnsdorf D. Fulfilling the Promises of CAD. *Sloan Management Review* 1992;33(3):74-86.
- [11] Mandorli F, Otto HE. Negative Knowledge and a Novel Approach to Support MCAD Education. *Computer-Aided Design and Applications* 2013;10(6):1007-1020.
- [12] Salehi V, McMahon C. Action Research into the Use of Parametric Associative CAD Systems in an Industrial Context. In: Proceedings of the 17th International Conference on Engineering Design (ICED'09), Vol. 5, M. Norell Bergendahl, et al., eds. p. 133-144.
- [13] Alducin-Quintero G, Contero M, Martín-Gutiérrez J, Guerra-Zubiaga DA, Johnson MD. Productivity Improvement by Using Social-Annotations about Design Intent in CAD Modeling Process. *Online Communities and Social Computing* 2011:153-161
- [14] Alducin-Quintero G, Rojo A, Plata F, Hernández A, Contero M. 3D Model Annotation as a Tool for Improving Design Intent Communication: A Case Study on Its Impact in the Engineering Change Process. In: Proceeding of the ASME International Design Engineering Technical Conferences and Computers and Information in Engineering Conference; 2012. p. 349-356.
- [15] Drury JL, Pfaff MS, Klein GL, Liu Y. Decision Space Visualization: Lessons Learned and Design Principles. *Human-Computer Interaction. Interaction Modalities and Techniques* 2013:658-667.
- [16] Shneiderman B, Plaisant C. *Designing the User Interface: Strategies for Effective Human-Computer Interaction*. 5th ed. Addison Wesley; 2009.
- [17] Nielsen J, Mack RL. *Usability inspection methods*. Wiley; 1994.
- [18] Norman DA. *The design of everyday things*. Reprint ed. Basic Books; 2002.
- [19] Chin JP, Diehl VA, Norman KL. Development of an Instrument Measuring User Satisfaction of the Human-Computer Interface. In: Proceedings of the SIGCHI Conference on Human factors in Computing Systems; 1988. p. 213-218
- [20] Lenne D, Thouvenin I, Aubry S. Supporting Design with 3D-Annotations in a Collaborative Virtual Environment. *Research in Engineering Design* 2009;20(3):149-155.
- [21] Whittenburg M. Model-based enterprise: an innovative technology-enabled contract management approach. *Journal of Contract Management* 2012;10:103-112
- [22] Quintana V, Rivest L, Pellerin R, Venne F, Kheddouci F. Will model-based definition replace engineering drawings throughout the product lifecycle? A global perspective from aerospace industry. *Computers in Industry* 2010;61(5):497-508.

- [23] Aberdeen Group. The Transition from 2D Drafting to 3D Modeling Benchmark Report – Improving Engineering Efficiency. Aberdeen Group, 2006, Boston.
- [24] Boehm B, Bayuk J, Desmukh A, Graybill R, Lane JA, Levin A, et al. Systems 2020 Strategic Initiative. DoD Systems Engineering Research Center, Technical Report SERC-2010-TR-009, August 29, 2010.
- [25] Quintana V, Rivest L, Pellerin R. Measuring and improving the process of engineering change orders in a model-based definition context”. *International Journal of Product Lifecycle Management* 2012;6(2):138-160.
- [26] Lubell J, Chen K, Horst J, Frechette S, Huang P. Model Based Enterprise/Technical Data Package Summit Report. NIST Technical Note 1753 (2012).
- [27] ASME Y14.41-2012 Digital Product Definition Data Practices. The American Society of Mechanical Engineers, 2012, New York.
- [28] ISO 16792:2006 Technical Product Documentation – Digital Product Definition Data Practices. Organisation Internationale de Normalisation, 2006, Genève, Suisse.
- [29] SASIG, Strategic Automotive Product Data Standards Industry Group, 3D Annotated Model Standard, in JAMAEIC0422008: Japan, 2008.
- [30] Contero M, Company P, Vila C, Aleixos N. Product data quality and collaborative engineering. *IEEE Computer Graphics and Applications* 2002;22(3):32-42.
- [31] Yang J, Han S. Repairing CAD model errors based on the design history. *Computer Aided Design* 2006;38(6):627-640.
- [32] VDA Recommendation 4955/4.1: Scope and Quality of CAD/CAM Data. German Association of the Automotive Industry (VDA), Frankfurt, Germany, 2006.
- [33] SASIG (Strategic Automotive Product Data Standards Industry Group) Product Data Quality Guidelines for the Global Automotive Industry recommendation version 2.1 [internet]. 2005 [cited 2013 Aug 2]. Available from: <http://www.odette.se/>
- [34] Conklin EJ, Yakemovic KC. A Process Oriented Approach to Design Rationale. *Human-Computer Interaction* 1991;6:357-391.
- [35] Horvath L, Rudas IJ. Modeling Behavior of Engineering Objects Using Design Intent Model. In: *Industrial Electronics Society, IECON'03. 29th Annual Conference of the IEEE*; 2003(1). p. 872-876.
- [36] Brissaud D, Garro O, Poveda O. Design Process Rationale Capture and Support by Abstraction of Criteria. *Research in Engineering Design* 2003;14:162-172.
- [37] Pena-Mora F, Sriram D, Logcher R. SHARED-DRIMS: SHARED Design Recommendation-Intent Management System. In: *Enabling Technologies: Infrastructure for Collaborative Enterprises, Proceedings, Second Workshop*; 1993. p. 213-221.
- [38] Bracewell R, Wallace K, Moss M, Knott D. Capturing design rationale. *Computer-Aided Design* 2009;41:173–186
- [39] Ganeshan R, Garrett J, Finger S. A Framework for Representing Design Intent. *Design Studies* 1994;15(1):59-84.
- [40] Quereshi S, Shah J, Urban SD, Harter E, Parazzoli C. et al. Integration model to support archival of design history in databases. In: *Proceedings of the 1997 ASME design engineering technical conferences and computers in engineering conference*; 1997.
- [41] Myers K, Zumel N, Garcia P. Acquiring Design Rationale Automatically. *Artificial Intelligence for Engineering Design, Analysis and Manufacturing* 2000;14(2):115-135.
- [42] Shum SJB, Selvin AM, Sierhuis M, Conklin J, Haley CB, Nuseibeh B. Hypermedia Support for Argumentation-Based Rationale: 15 Years on from Gibis and Qoc. *Rationale Management in Software Engineering* 2006:111–132
- [43] Szykman S, Sriram R, Regli W. The Role of Knowledge in Next-Generation Product Development Systems. *J. of Computing and Inf. Science in Engineering* 2001;1(1):3–11.
- [44] Chandrasegaran SK, Ramani K, Sriram RD, Horváth I, Bernard A, R.F. Harik, W. Gao. The evolution, challenges, and future of knowledge representation in product design systems. *Computer-Aided Design* 2013;45(2):204-228.
- [45] Umeda Y, Ishii M, Yoshioka M, Tomiyama T. Supporting conceptual design based on the function-behavior-state modeler, *Artificial Intelligence for Engineering Design, Analysis and Manufacturing* 1996;10(4):275-288.
- [46] Gero J, Design prototypes: a knowledge representation schema for design, *AI Magazine* 1990;11(4):26-36.
- [47] Harding JA, Popplewell K, Fung RYK, Omar RA. An intelligent information framework relating customer requirements and product characteristics, *Computers in Industry* 2001;44:51-65

- [48] Du Plessis M, What bars organisations from managing knowledge successfully? *International Journal of Information Management* 2008;28:285-292.
- [49] Kunz W, Rittel HWJ. *Issues as elements of information systems*. Center for Planning and Development Research. University of California at Berkeley. 1970.
- [50] Moran TP, Carroll JM. *Design rationale: concepts, techniques, and use*. Mahwah (New Jersey): Lawrence Erlbaum Associates, Inc.; 1996.
- [51] Burge JE, Brown DC. Software engineering using rationale. *Journal of Systems and Software* 2008;81:395-413.
- [52] Chandrasekaran B, Goel A, Iwasaki Y. Functional representation as design rationale. *Computer* 1993;26:48-56.
- [53] Liang Y, Liu Y, Kwong CK, Lee WB. Learning the “Whys”: Discovering design rationale using text mining-An algorithm perspective. *Computer-Aided Design* 2012;44(10):916-930.
- [54] Boujut JF, Dugdale J. Design of a 3D Annotation Tool for Supporting Evaluation Activities in Engineering Design. *Cooperative Systems Design, COOP* 2006;6:1-8.
- [55] Ding L, Liu S. Markup in Engineering Design: A Discourse. *Future Internet* 2010;2:74-95.
- [56] Camba J, Contero M. Integration of Model-Based Design Annotations in Product Lifecycle Management Systems to Facilitate Design Intent Communication, In: *Proceedings of the 10th International Symposium on Tools and Methods of Competitive Engineering*; 2014.
- [57] Camba J, Contero M, Johnson M, Management of Visual Clutter in Annotated 3D CAD Models: A Comparative Study. *Lecture Notes in Computer Science* 2014;8518:405–416.
- [58] Camba J, Contero M, Salvador-Herranz G, Speak with the Annotator: Promoting Interaction in a Knowledge-Based CAD Environment Built on the Extended Annotation Concept. In: *18th IEEE International Conference on Computer Supported Cooperative Work in Design*; 2014
- [59] Iyer N, Jayanti S, Lou K, Kalyanaraman Y, Ramani K. Shape-based Searching for Product Lifecycle Applications. *Computer-Aided Design* 2005; 37:13; 1435-1446.
- [60] Ullman DG. *The Mechanical Design Process*, 4th ed. Mc Graw Hill, Boston. 2010

## Appendix: Questions given to participants

### Instructions

You have been given the task to make a number of modifications to an existing 3D model (“*bracket.SLDPRT*”) and find certain information. This 3D model has been annotated to provide design and modeling information within the geometry. During the annotation process, multiple designers have collaborated to provide a variety of data based on design requirements, test results, revisions, previous experience, etc.

As in many other cases in parametric modeling, each modification that needs to be performed can be accomplished in different ways. However, previous knowledge and experience from the team of designers and engineers have helped determine the most effective approaches. This information has been captured and included within the model in the form of 3D annotations.

**Question 1: According to the annotations, if you want to modify the size of the M4 machine holes located on the base of the model, you must first:**

- a) Your answer: \_\_\_\_\_
- b) I wasn’t able to find enough information in the annotations to answer confidently.

*Correct answer: Contact Design Center*

*Answer is provided by the following model annotation(s):*

- “*Contact Design Center if modifying M4 holes*” connected to Feature “*M4x0.7 Tapped Hole 1*”

**Question 2: According to the annotations, what is the range of acceptable angles for the feature shown in Fig. A.1?**

- a) Min angle = \_\_\_\_\_ Max angle = \_\_\_\_\_
- b) I wasn’t able to find enough information in the annotations to answer confidently.

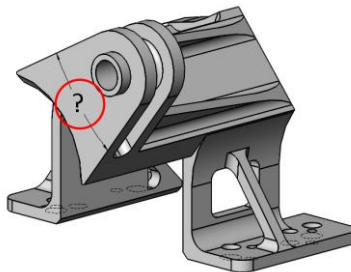

Fig. A.1

*Correct answer: Min angle = 20° and Max angle = 27°*

*Answer is provided by the following model annotation(s):*

- “*Ensure a minimum angle of 20 degrees*” connected to Feature “*Boss-Extrude3*”  
- “*Ensure a maximum angle of 27 degrees*” connected to Feature “*Boss-Extrude3*”

**Question 3: According to the annotations, the most effective procedure to create the second rib on the back of the model (on the available side) as shown in Fig. A.2 is:**

- a) Use Mirror about a center vertical plane to create a symmetrical image of the first rib.
- b) Create a new sketch on the inner flat surface and extrude.
- c) Use linear pattern using the original rib as seed to create the second rib.
- d) Use the existing sketch of the existing rib to create a new extrusion with an offset distance.
- e) I wasn’t able to find enough information in the annotations to answer confidently.

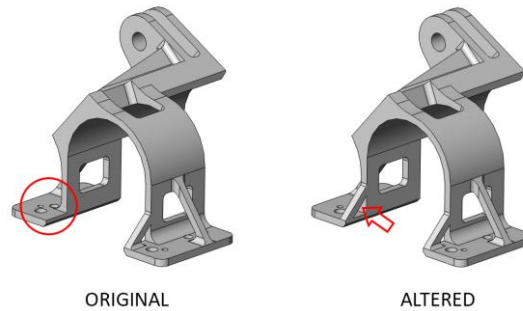

Fig. A.2.

Correct answer: B

Answer is provided by the following model annotation(s):

- "Do not use symmetry or pattern for ribs. Angles may vary" connected to Feature "Boss-Extrude9"

**Question 4: When modifying the dimensions of the side ribs to 5mm x 5mm (Fig. A.3), some errors and unwanted effects occur in the model, such as the one shown in Fig. A.4. According to the annotations, the most effective procedure to resolve these effects is:**

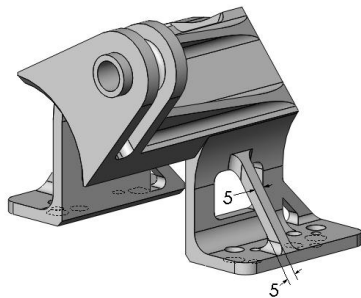

Fig. A.3

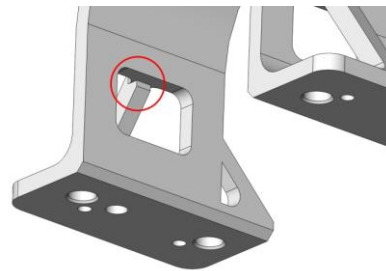

Fig. A.4

- Reduce the height of the rectangular cut (Cut-Extrude1) to 12mm or less so it doesn't interfere with the modified rib.
- Move the rectangular cut down, so that the new distance from the bottom of the cut to the bottom of the part is 8mm. Then, reduce the radius of Fillet7 to 3mm. Delete Fillet11.
- Increase the angle of the ribs.
- Because of preliminary FEA results, the new dimensions of the side ribs (5mm x 5mm) are not allowed.
- I wasn't able to find enough information in the annotations to answer confidently.

Correct answer: B

Answer is provided by the following model annotation(s):

- "Optimum rib angle. Maintain in future versions" connected to Feature "Boss-Extrude8"
- "3.00 x 3.00 Minimum cross section defined by FEA analysis" connected to Feature "Boss-Extrude8"
- "Keep dimensions of the cut constant. Modify position if necessary" connected to Feature "Cut-Extrude1"