

DENSITY

PARQUE ALCOSA

Density. Parque Alcosa, Alfafar. Valencia
Alejandro Espallargas Omedas
PFC taller H 2012/2013

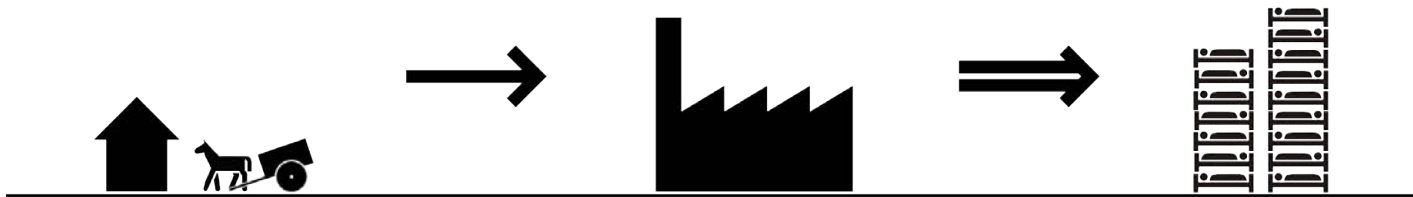





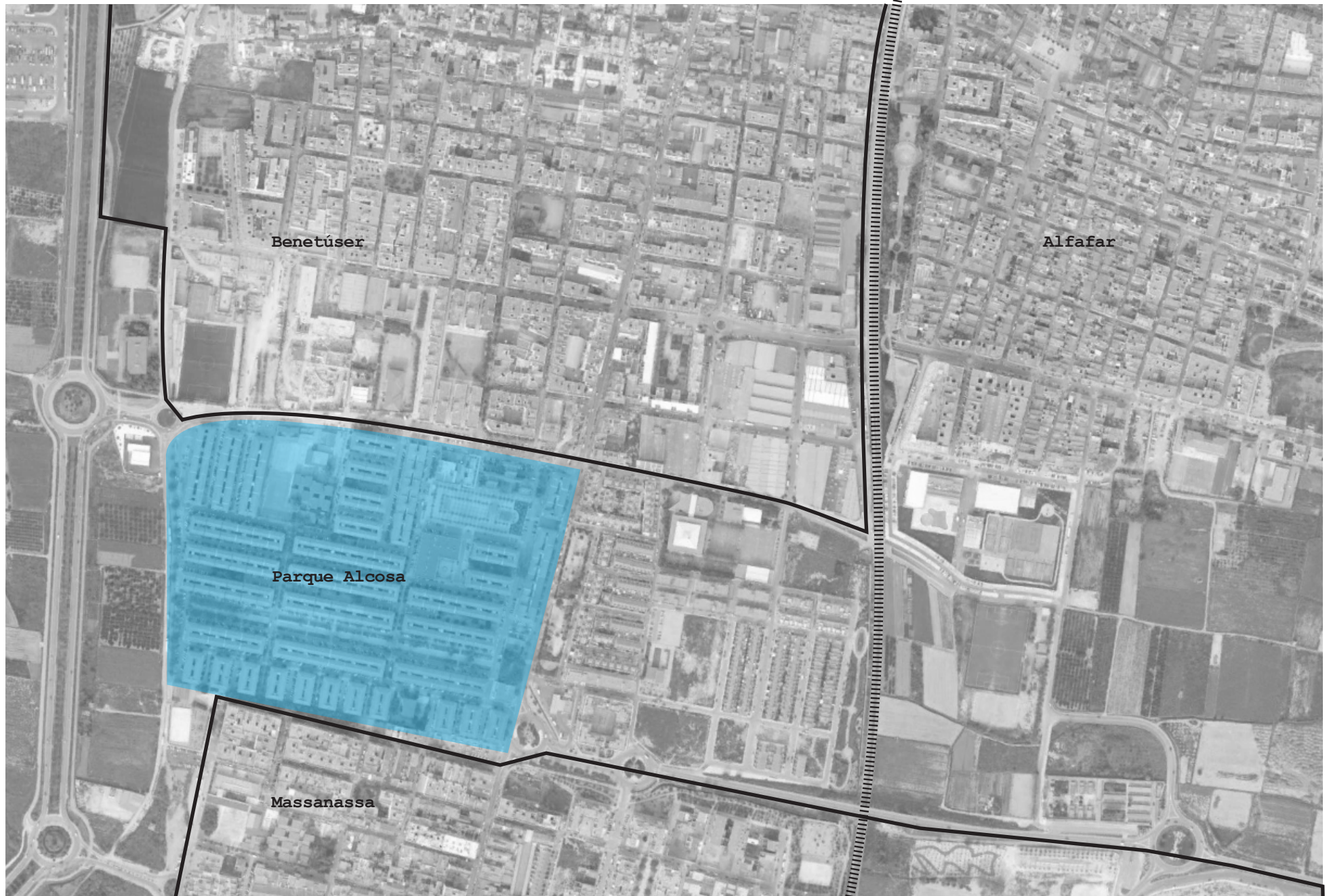

Benetúser

Alfafar

Parque Alcosa

Massanassa

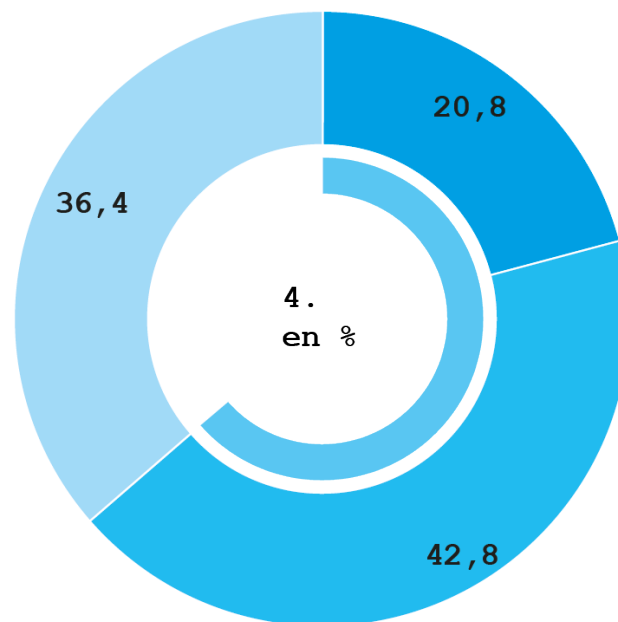

_Demografía estructural:
inmigración no nacional_20,8%
inmigración nacional_42,8%
comunidad valenciana_36,4%



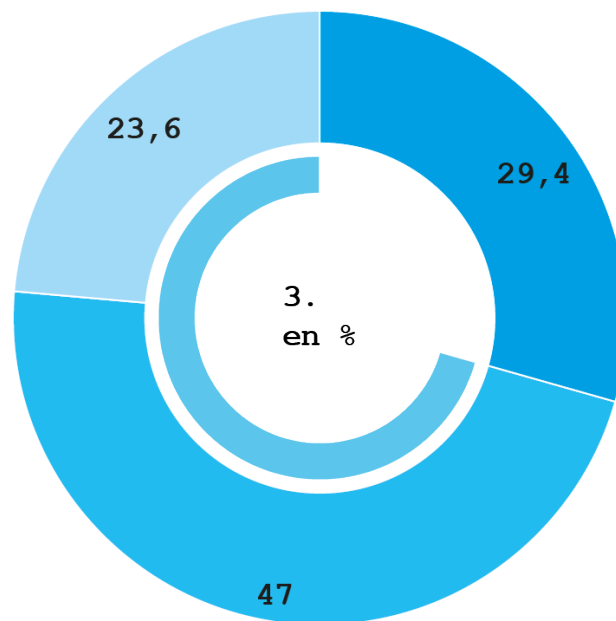

_Rangos de edad:
menos de 29 años_29,4%
entre 30 y 64 años_47%
más de 65 años_23,6%



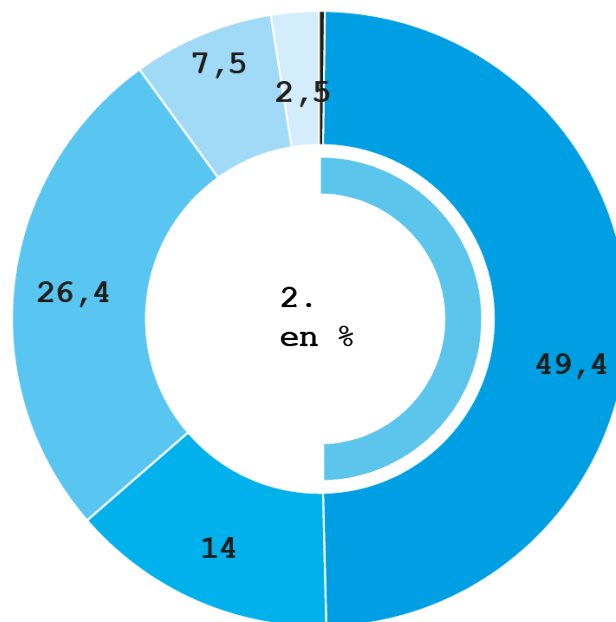

_Formación académica:

analfabetos_0,2%
sin estudios_49,4%
estudios menores_14%
nivel básico_26,4%
nivel medio_7,5%
nivel alto_2,5%





1_Talleres infantiles



2_Teatro para Niños



3_Comida de la 3ª Edad



4_Misas Rocieras



5_Los indispensables Barracones



6_Orba Rock



1_Koordinadora de Kolectivos



2_Asoc. Cultural Andaluza



3_Asoc. de Jubilados del Barrio Orba



4_Asoc. de Vecinos Los Alfafres



5_Asoc. Deportiva Barrio Orba



6_Asoc. Mujeres en Marcha

1. Rehabilitar el Espacio Público.

2. Reactivar el Tejido Socio-Económico

3. Infección Positiva



LIFE

**THE YOUTH
COMMUNES**
New Way of Living
Confronts the U.S.

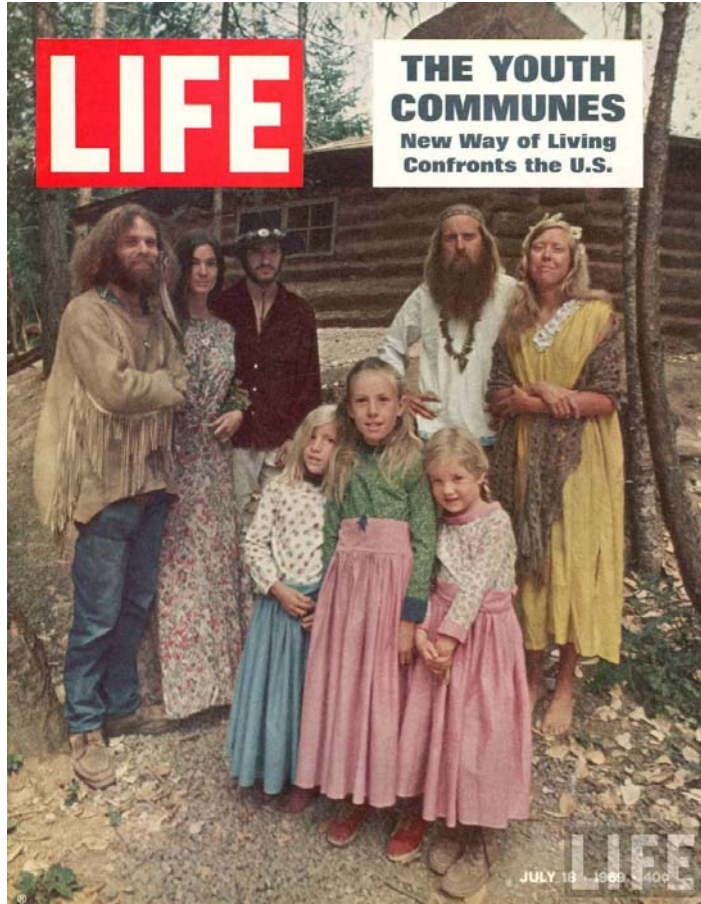

JULY 18, 1969 400

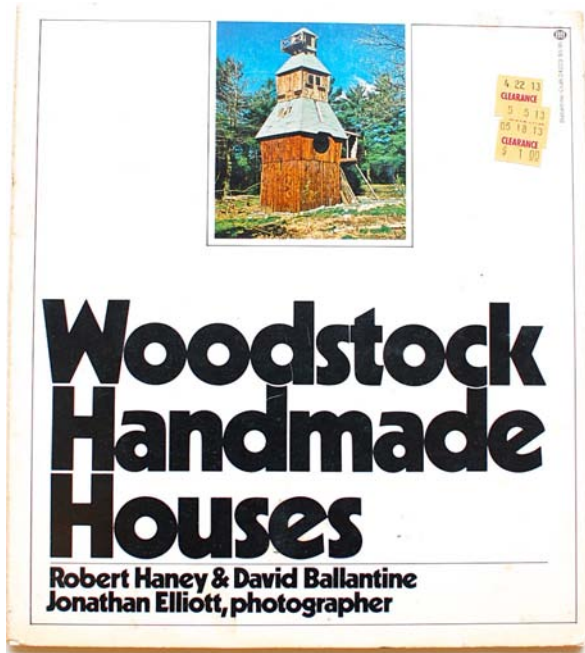



hand
made
urbanismo
El Campode Cebada

Escalas de intervención:

Escala de barrio.
Una ciudad dentro de otra.

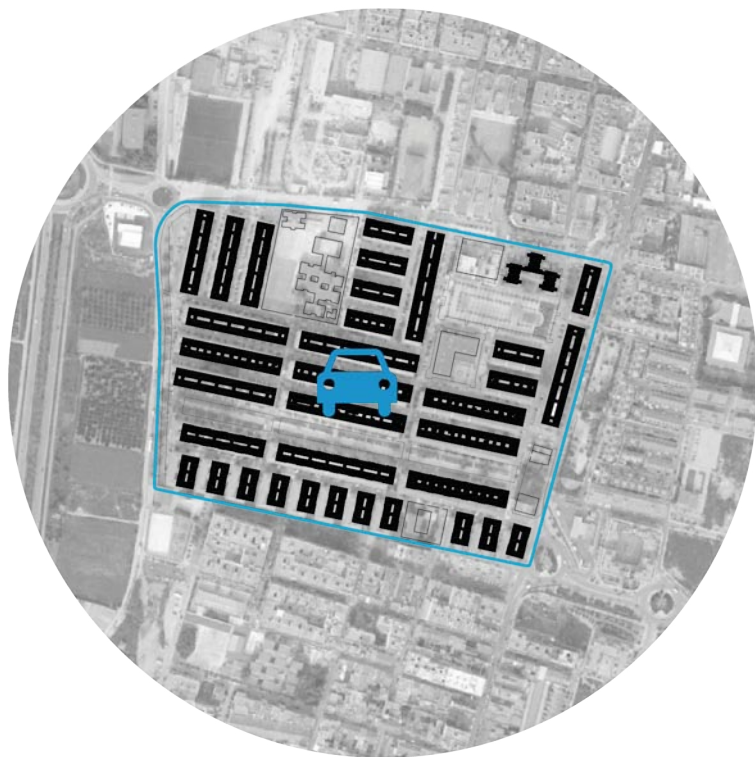

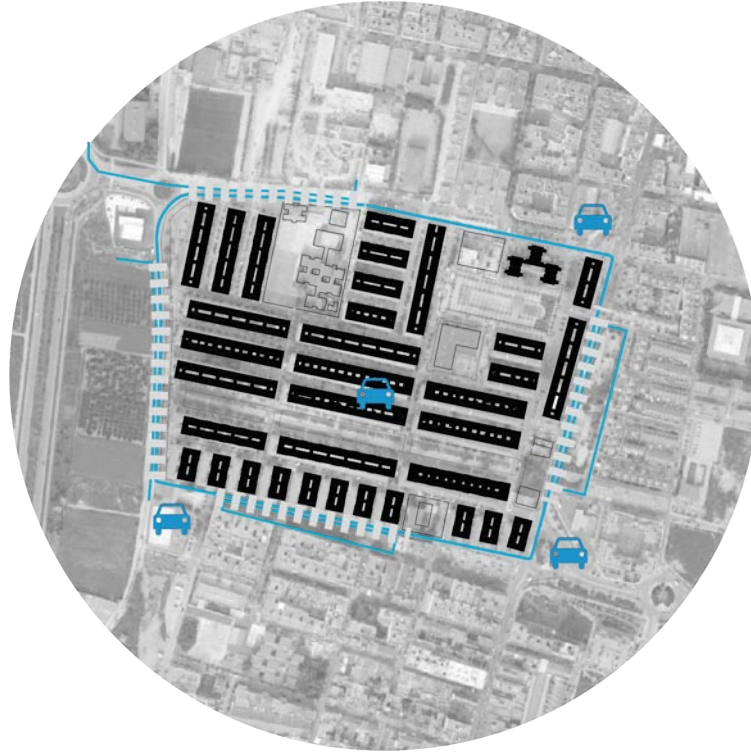

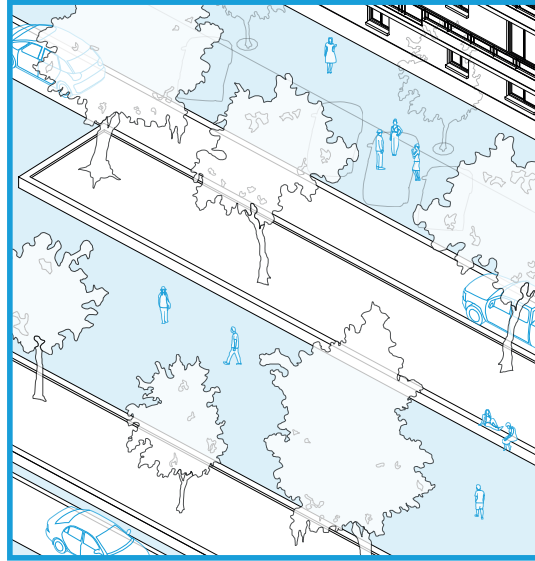
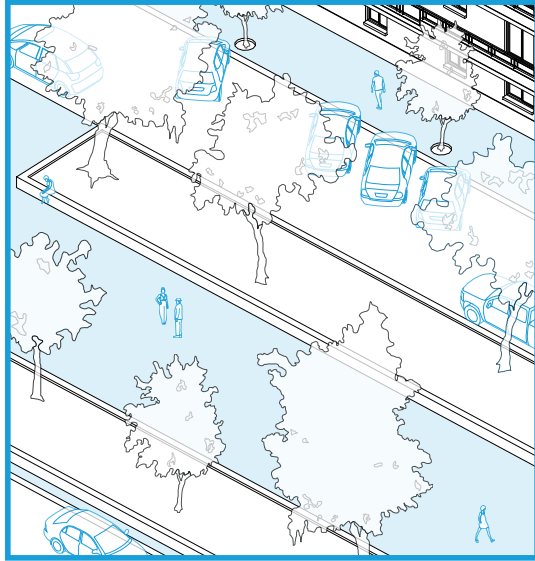

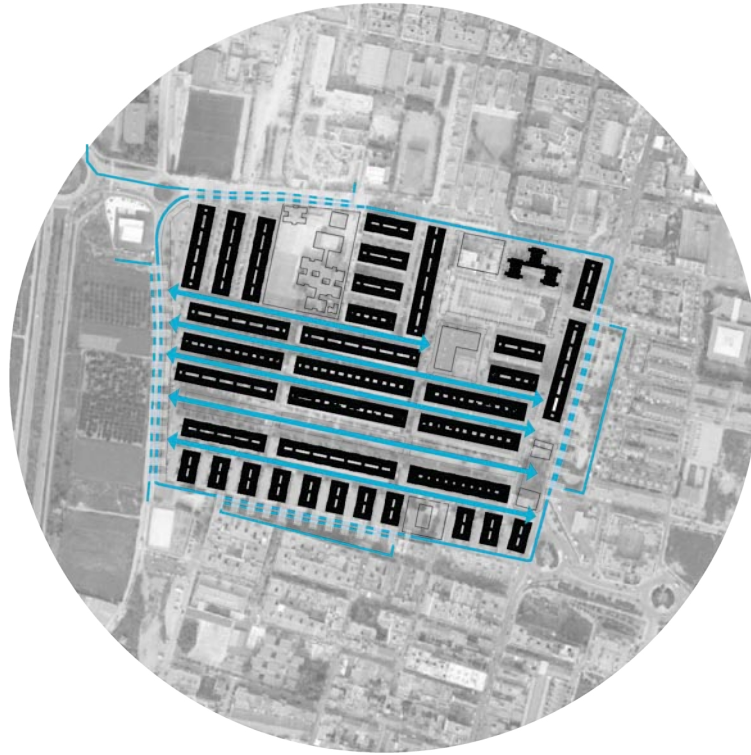





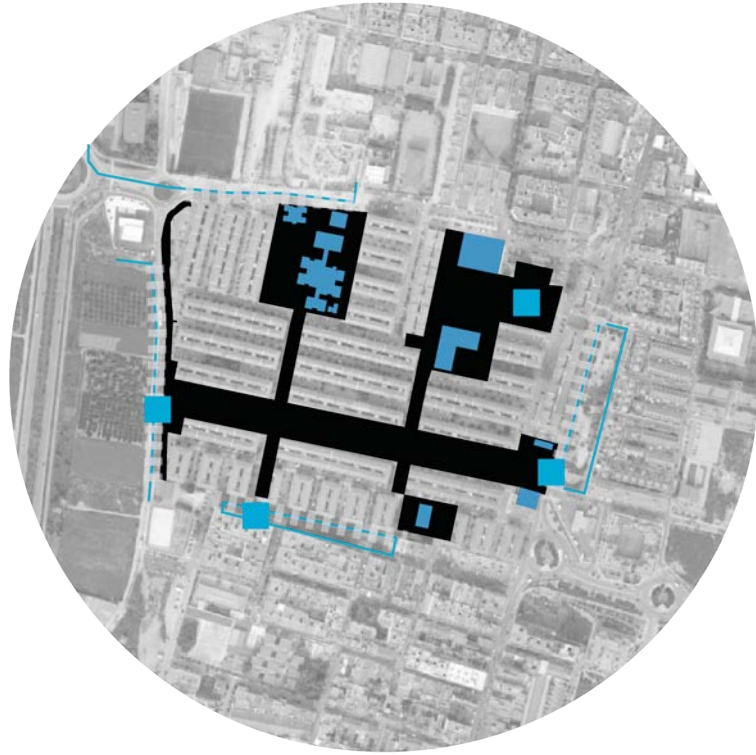

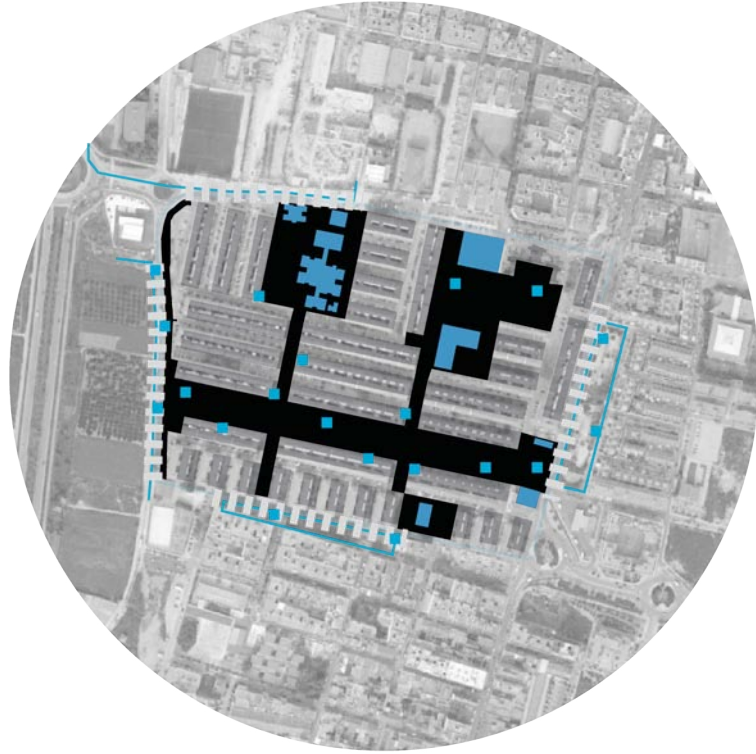



*célula ventanosa, j. l. chaneac / red bull music academy, langarita y navarro / tiny travelling theatre, abern / architecture
/ cherry blossom pavilion, amid cerog*

1. Rehabilitar el Espacio Público.

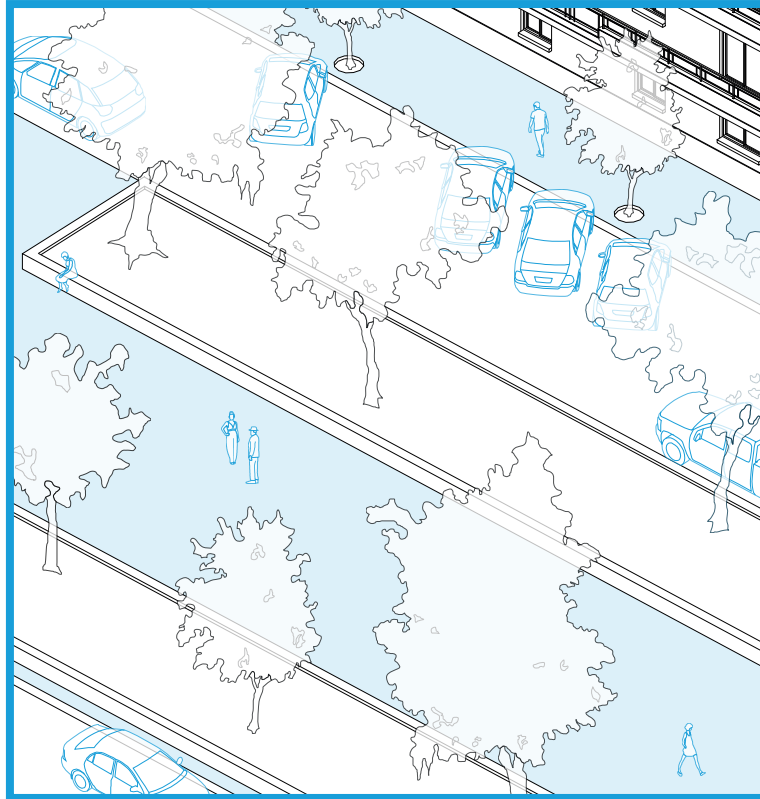

Estado actual.

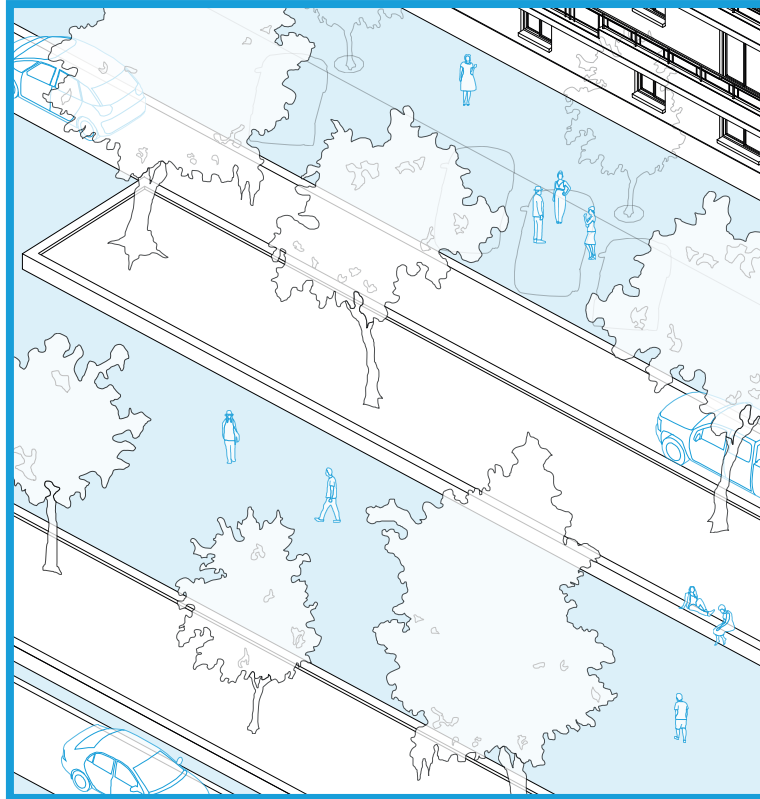

Peatonalización Gradual 1.

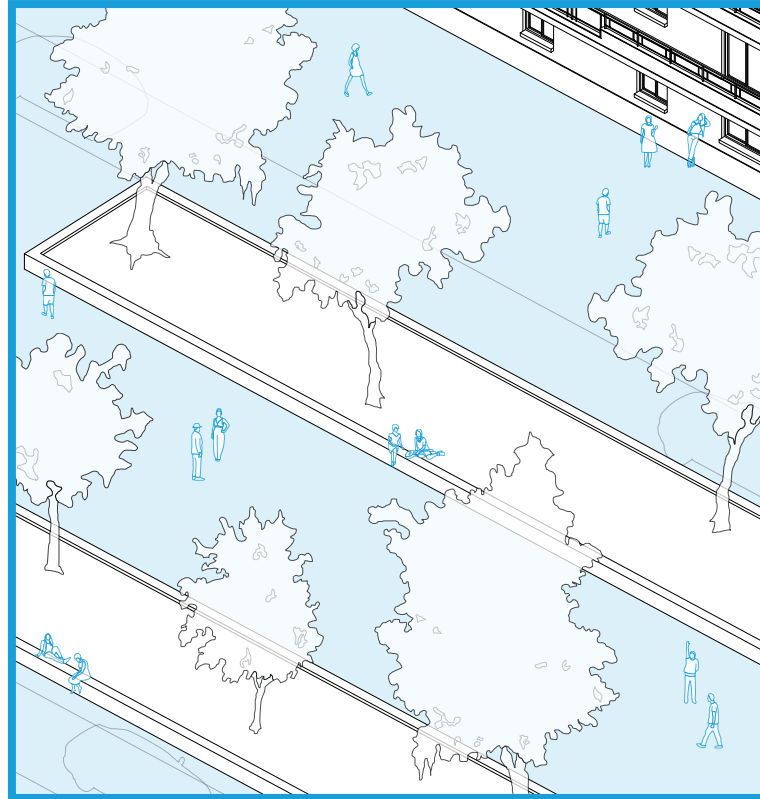

Peatonalización Gradual II.

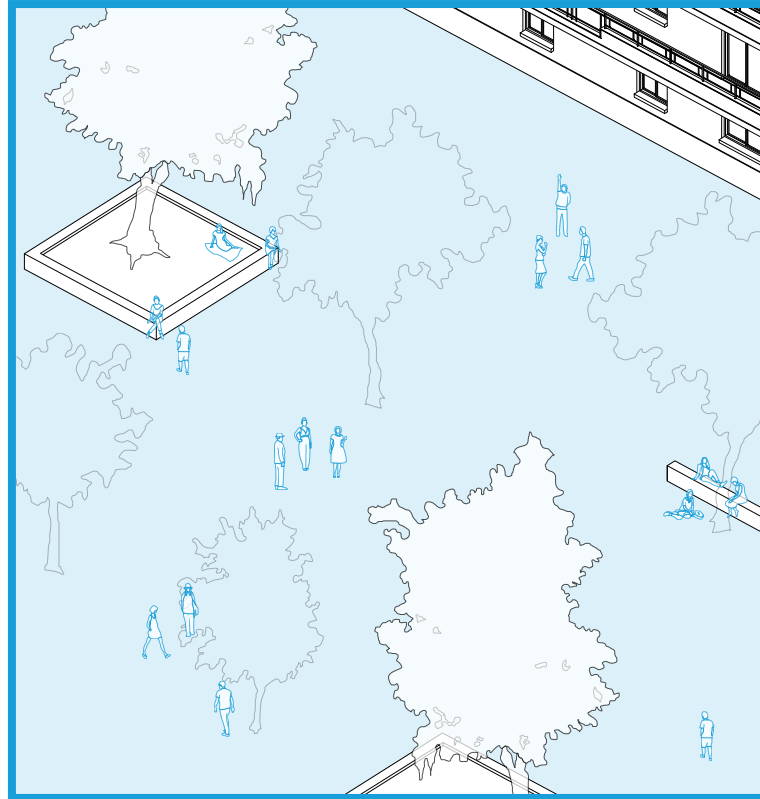

Supresión de Jardineras.

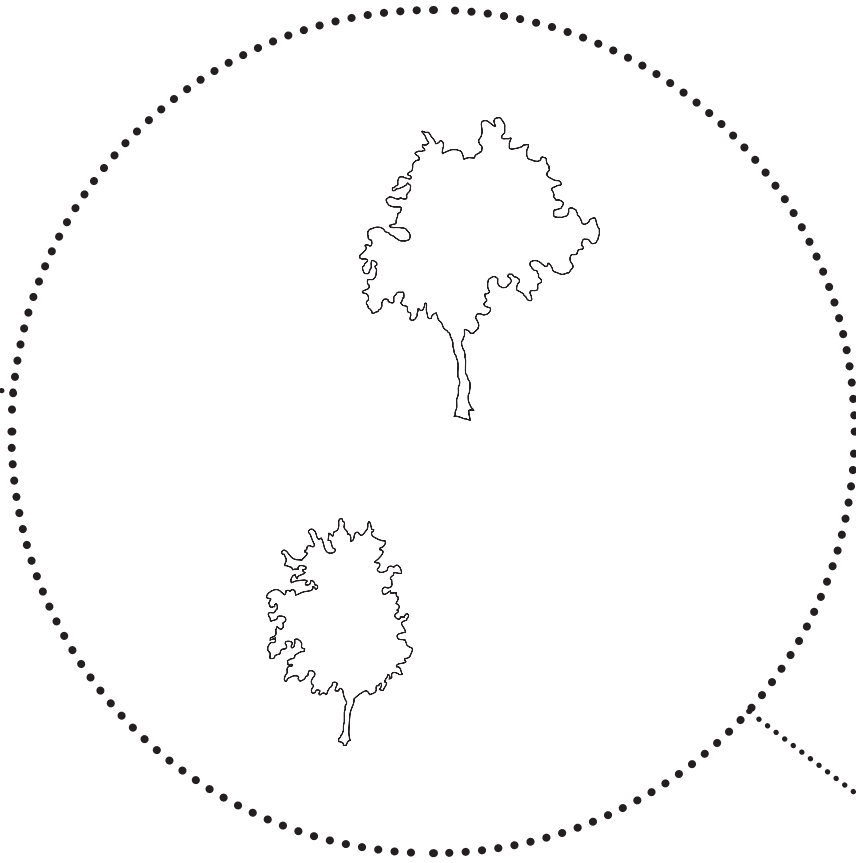
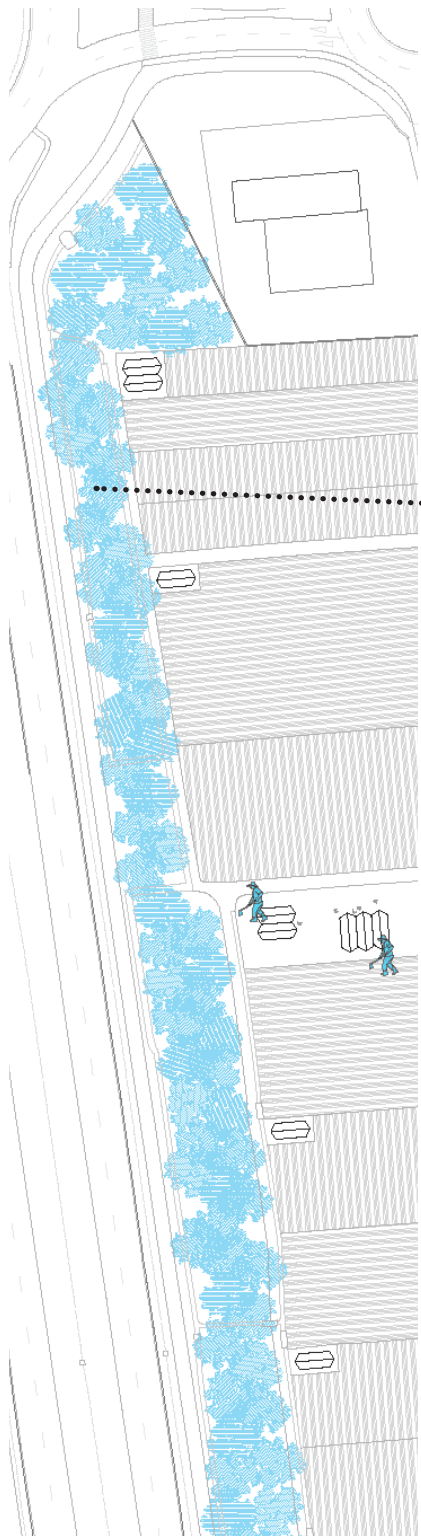

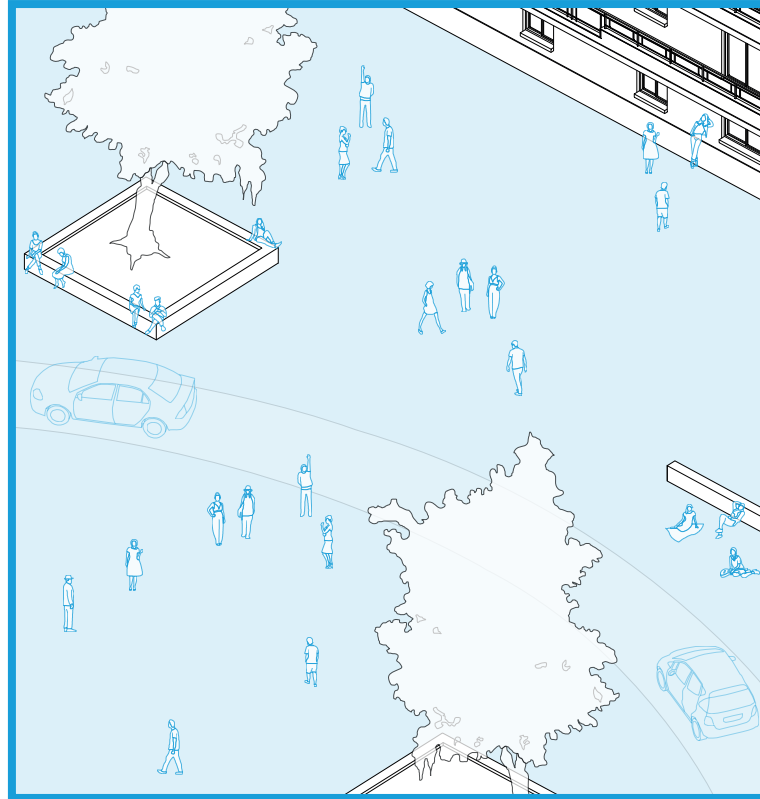

La Calle Meandro.

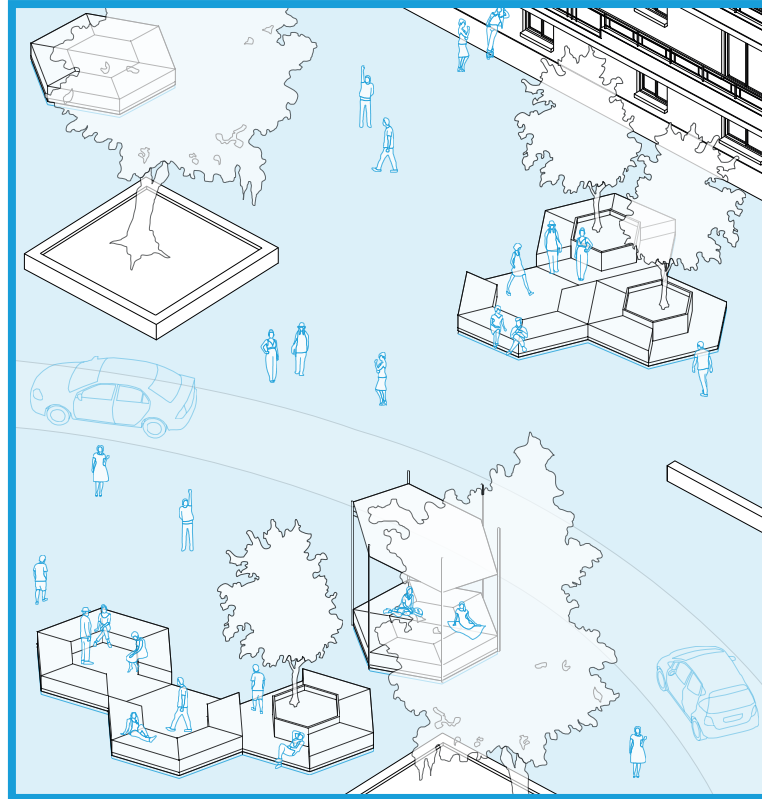

Las Partes Sueltas.



Archipiélago. Jerónimo Hagerman



RUS Niamey . Basurama



El Campo de Cebada, Madrid.

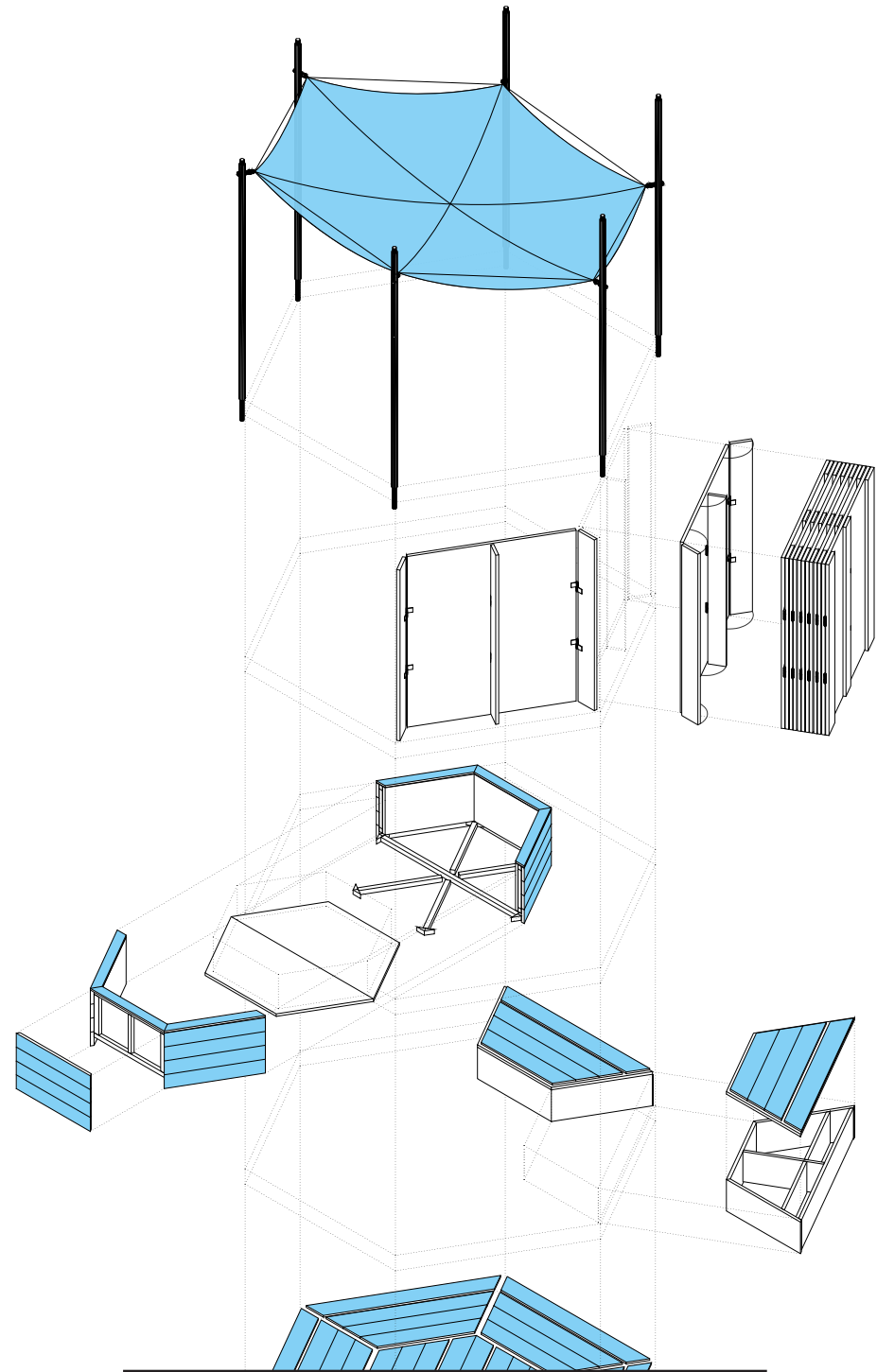
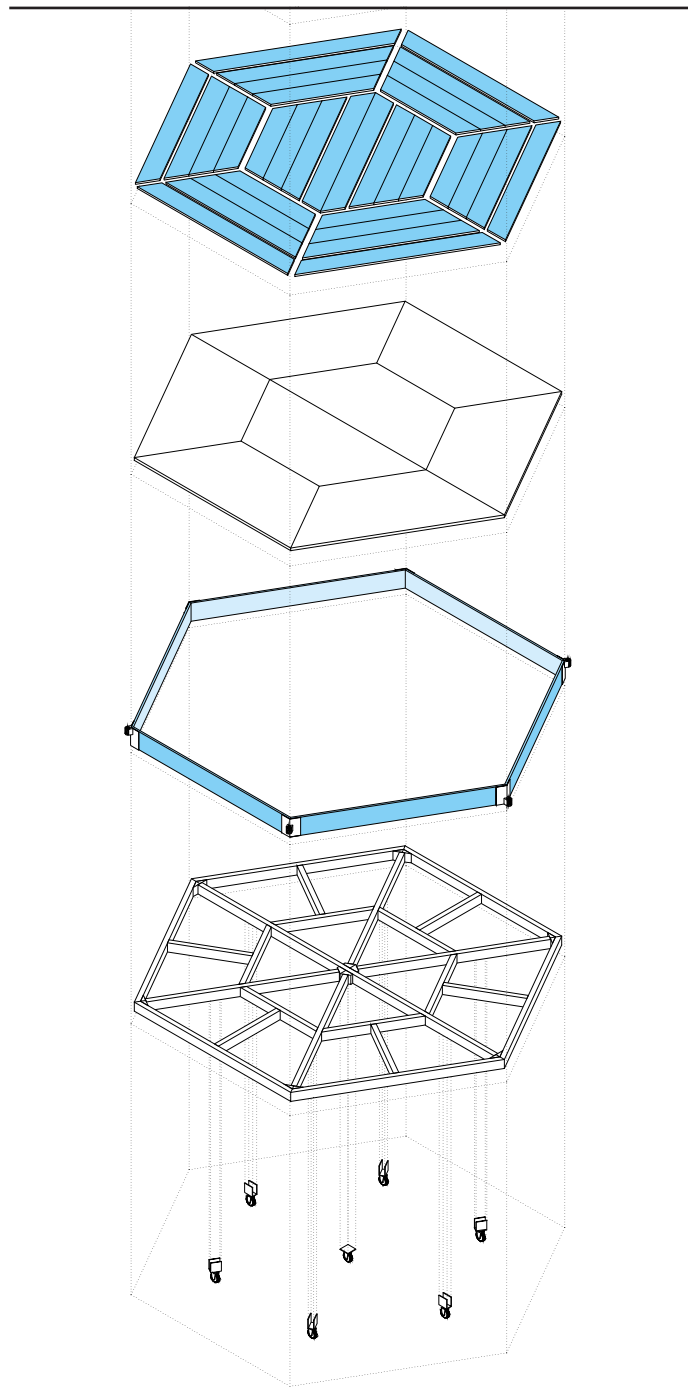

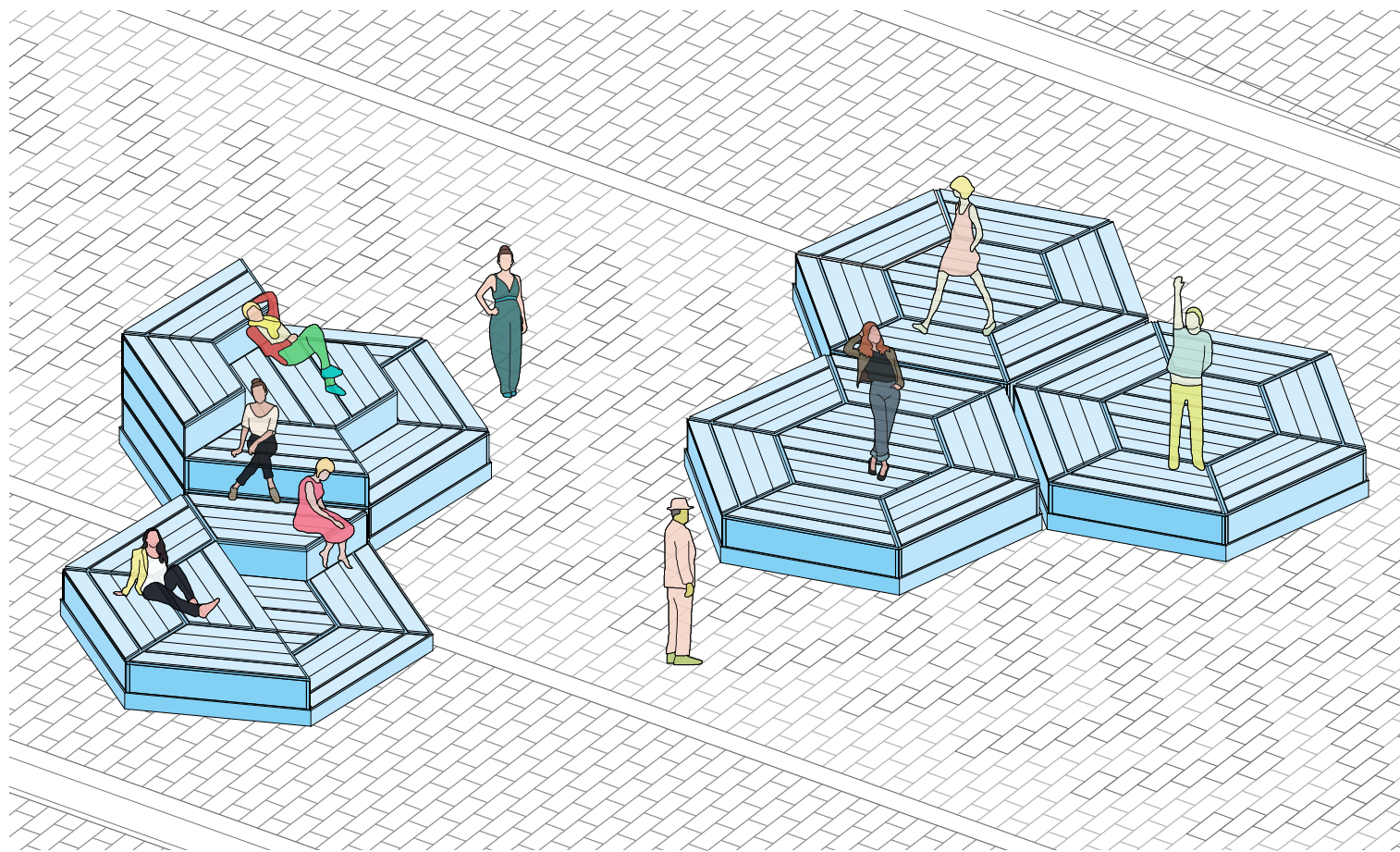

Gradas y Escenario.

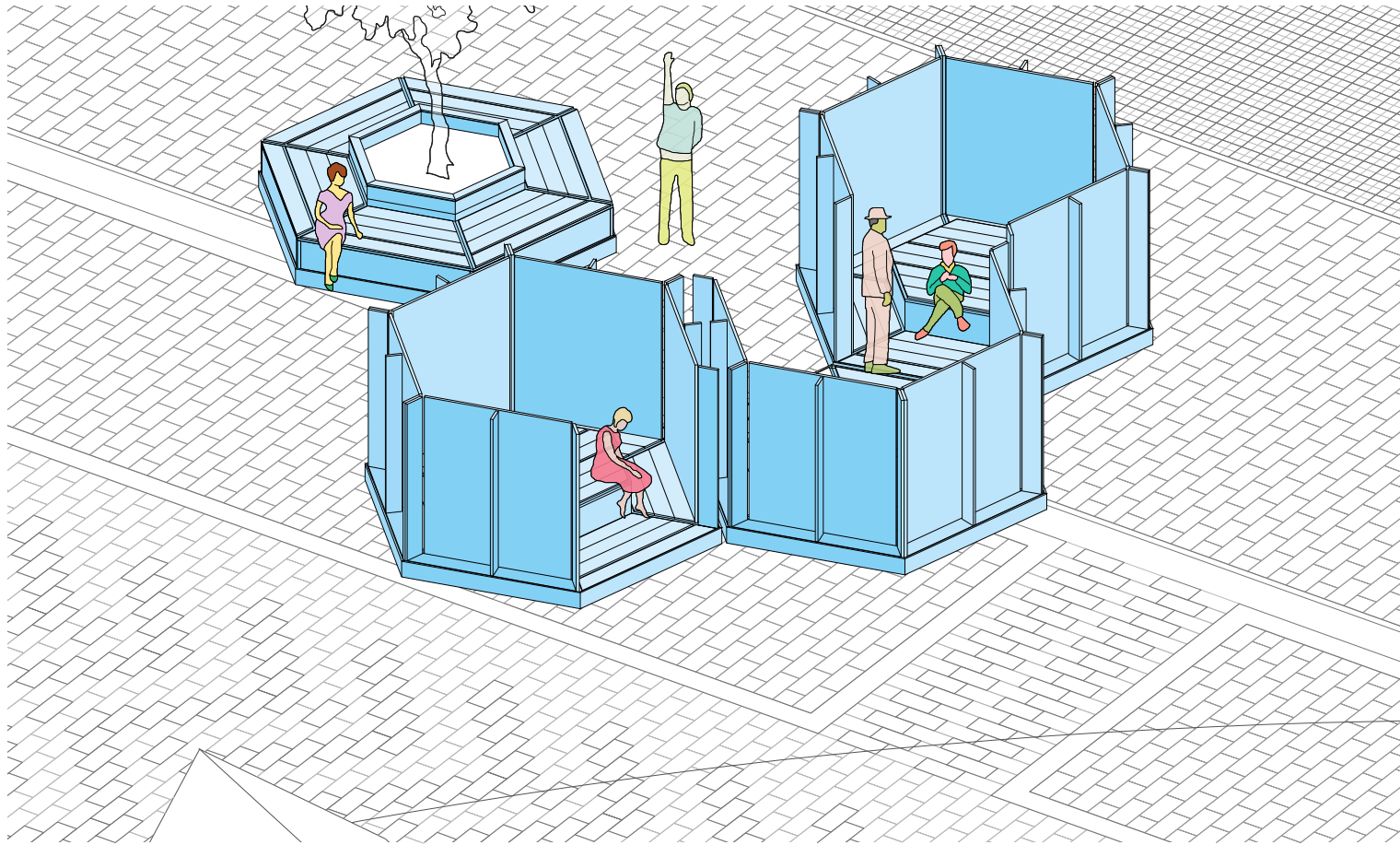

Espacios de intimidad.

2. Reactivar el Tejido Socio-Económico.



Miembros de la Koordinadora, entre los que se encuentran algunos de sus fundadores, en sus inicios.



Espacio cedido por el Ayuntamiento en el anfiteatro de la plaza Poeta Miguel Hernández, finales años 80.



Dois miembros de la Koordinadora cuidan las plantas de la plaza, finales años 80.



Niños haciendo manualidades, años 90.



Una de las reuniones del grupo, años 90.



Uno de los fundadores de la Koordinadora, Antonio Valero, junto a miembros de otras entidades. Finales años 80.



Taller de pintura para los más pequeños, años 90.



Grupo de limpieza pintando en anfiteatro.



Grupo las Cuatro Rosas. Degustación tras el taller de cocina, 2010.



Grupo las Cuatro Rosas. Grupo de inversores, 2010.



Ceramistas Barrio Orba.



Almacén de Productos de Segunda Mano.

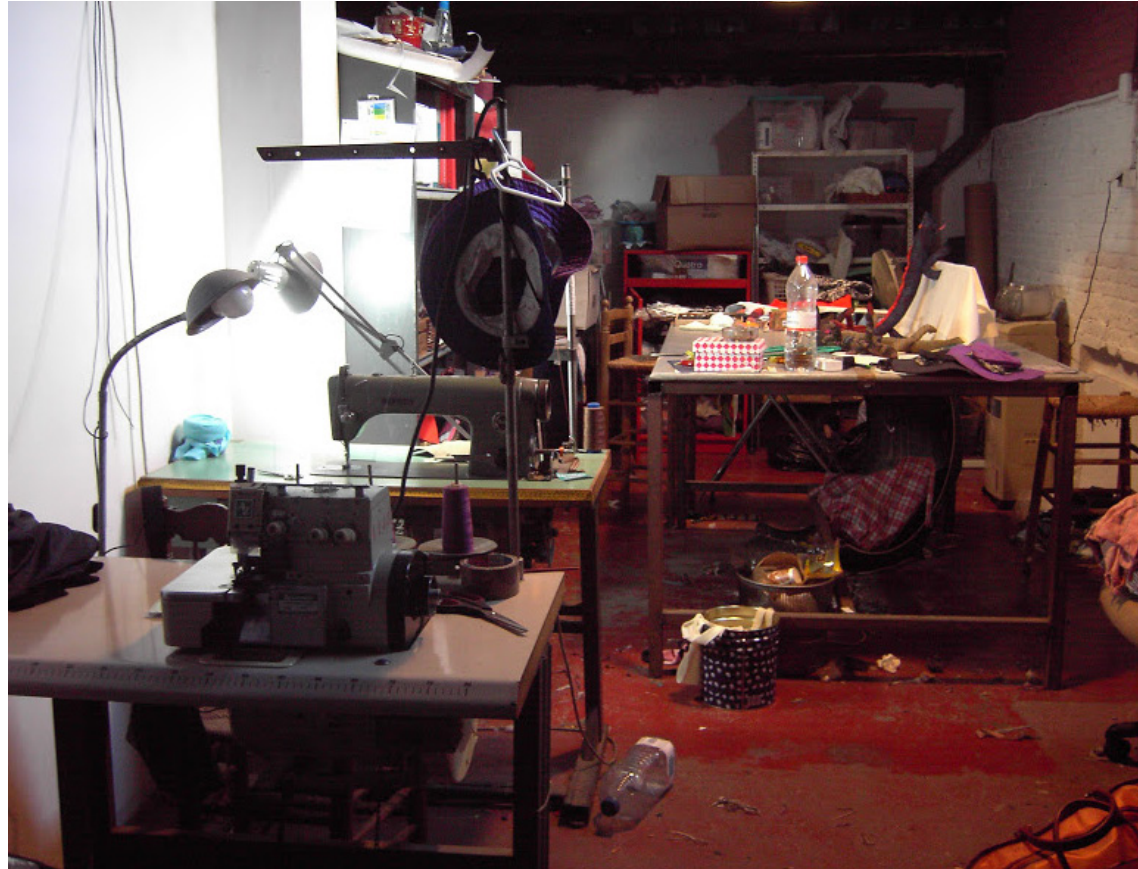

Espacios de Trabajo.



Espacio de Trabajo.

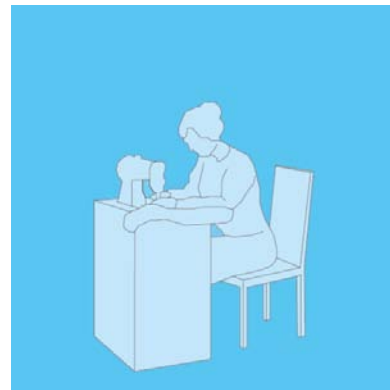

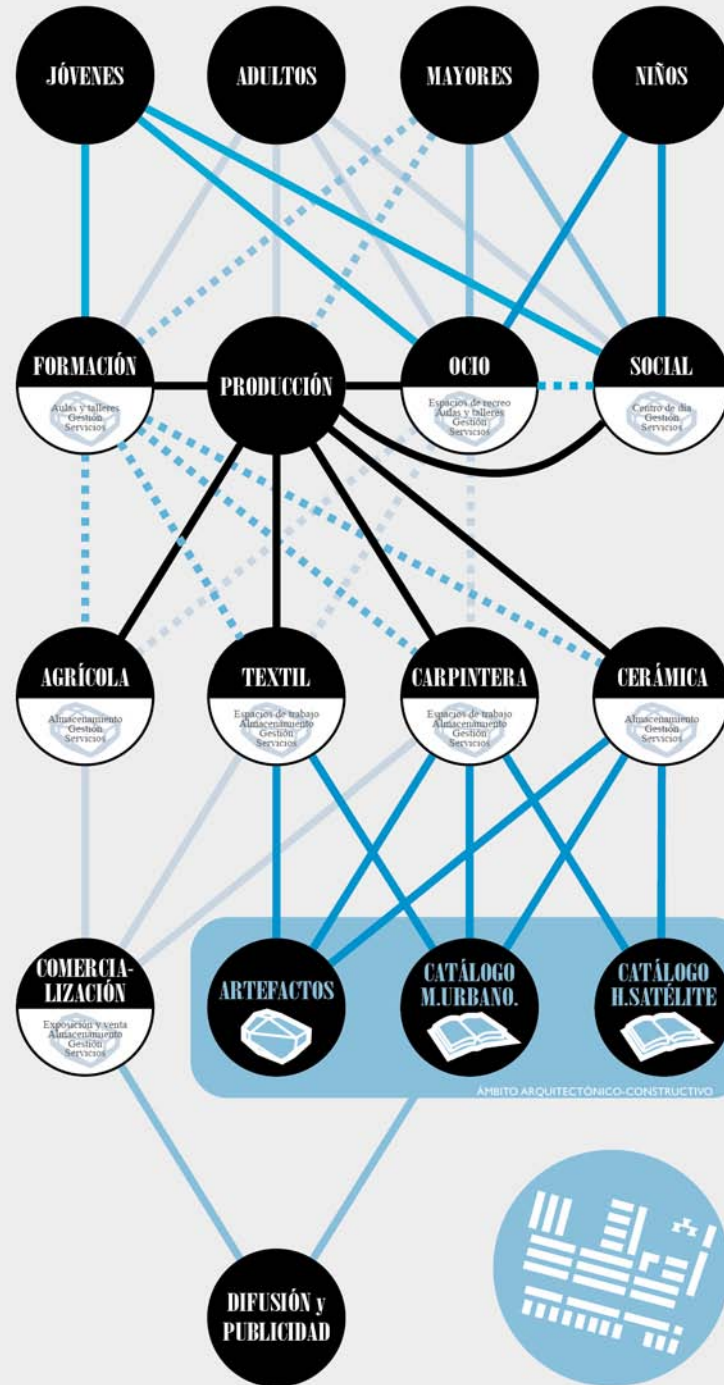

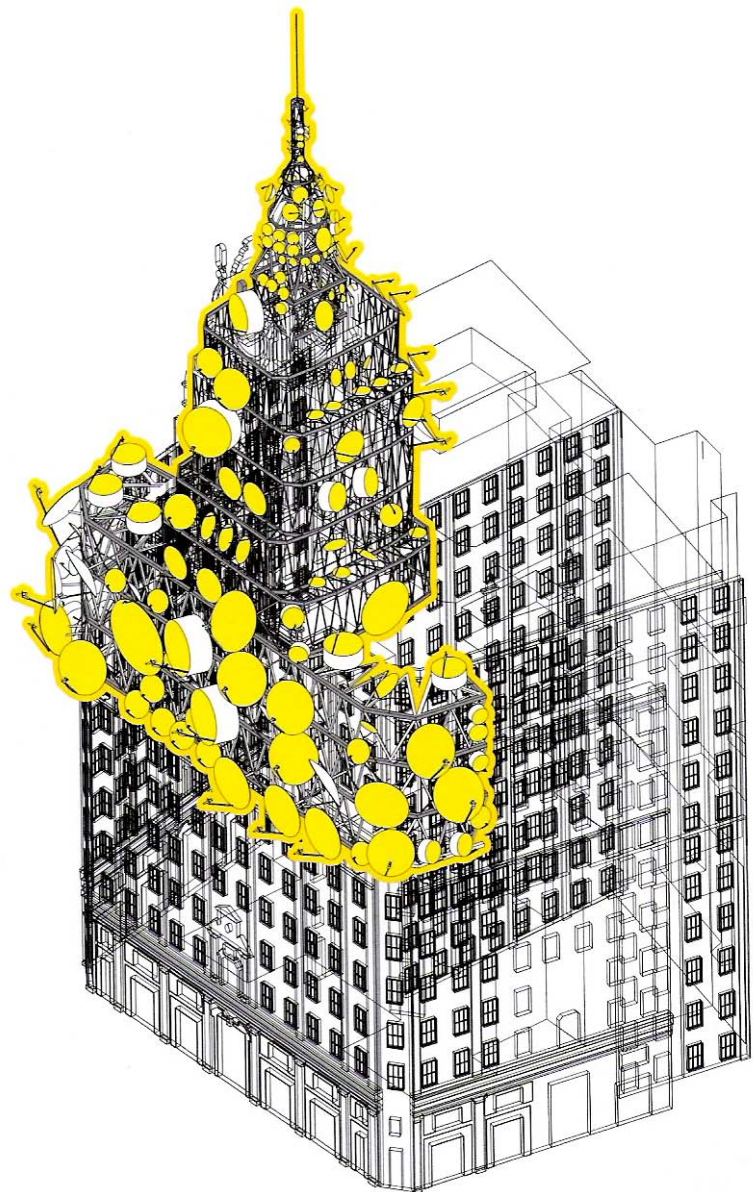

Gran Via Zona Franca. Acebox.Alonso

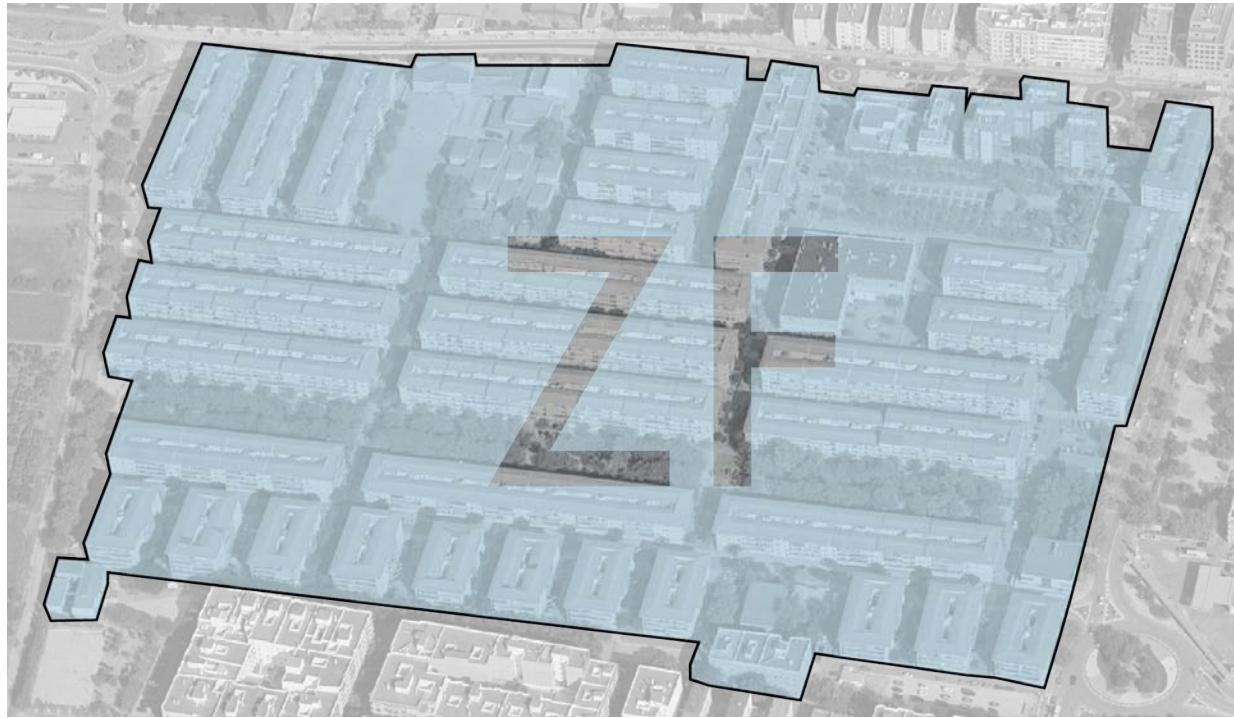

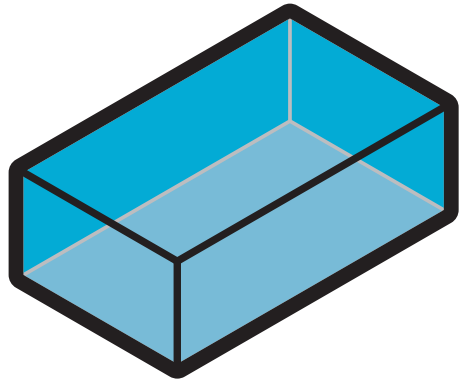

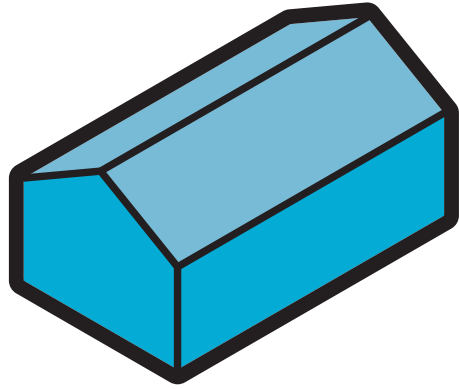





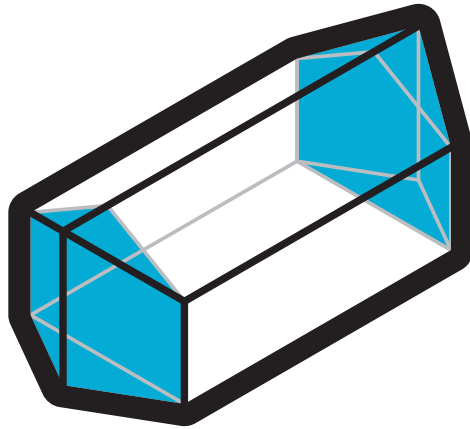

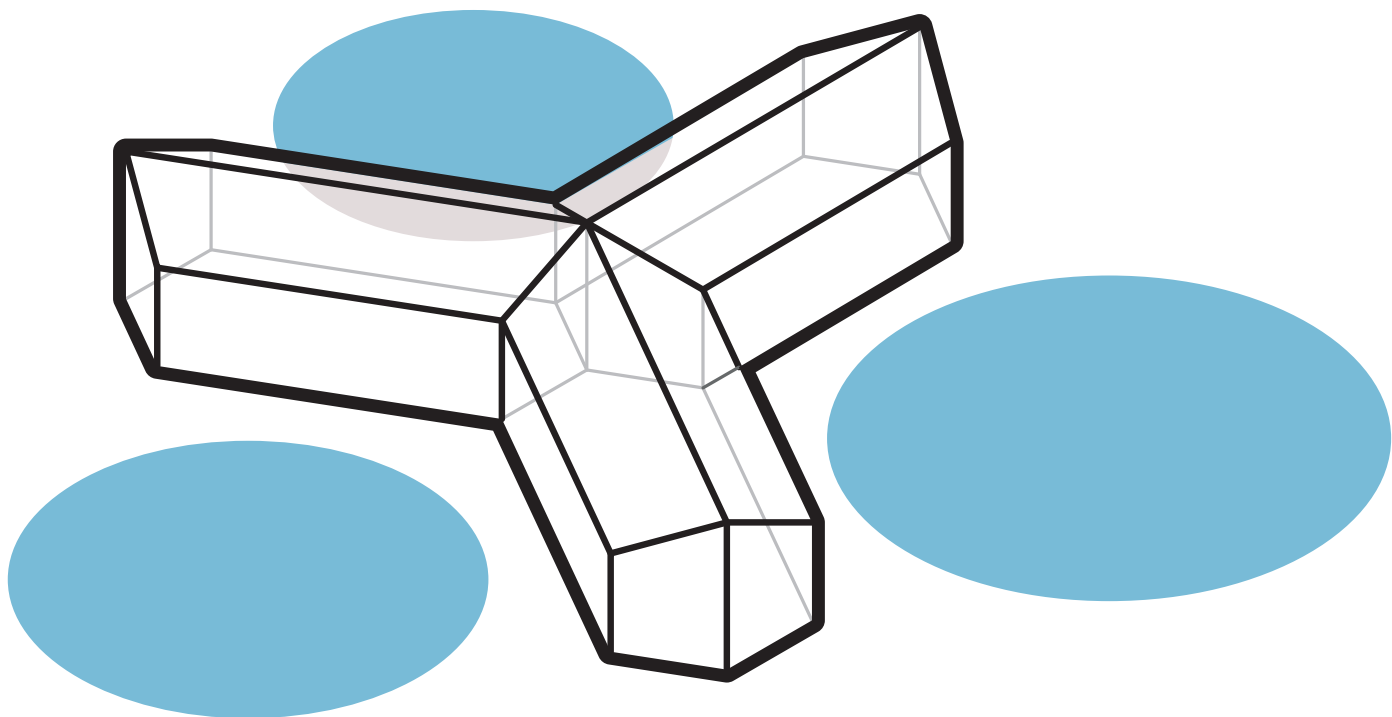

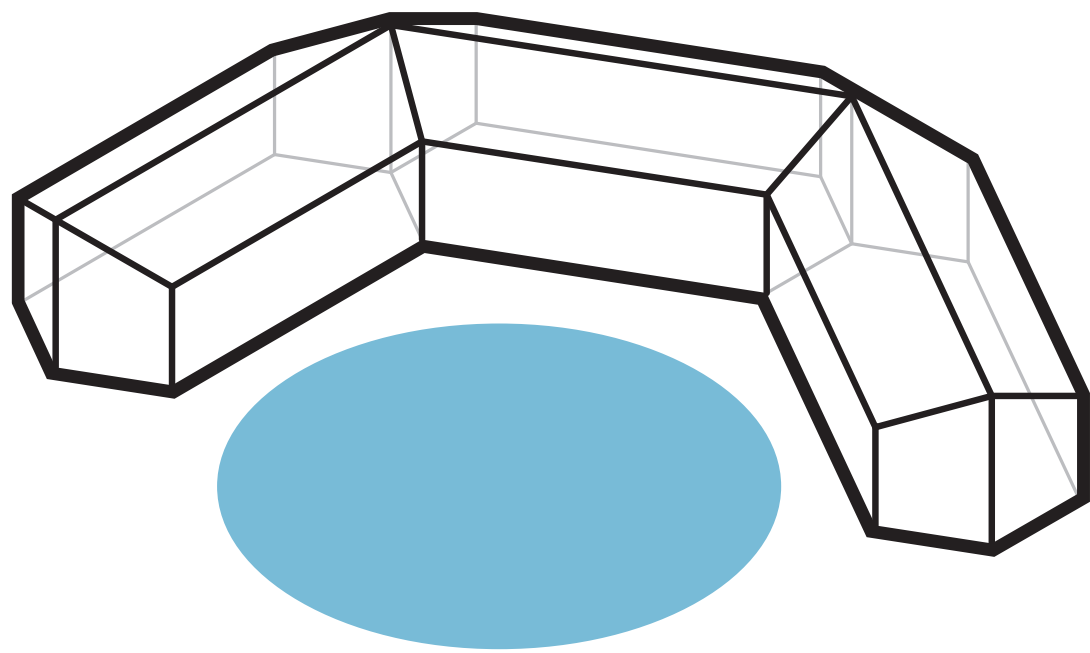

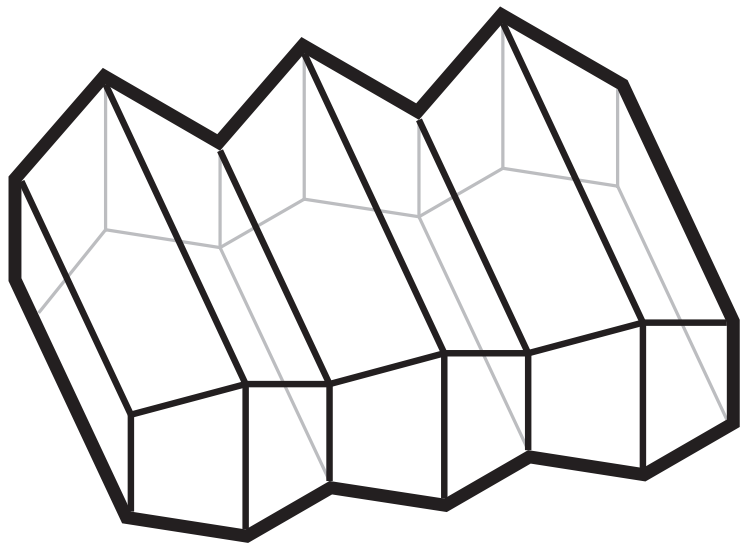
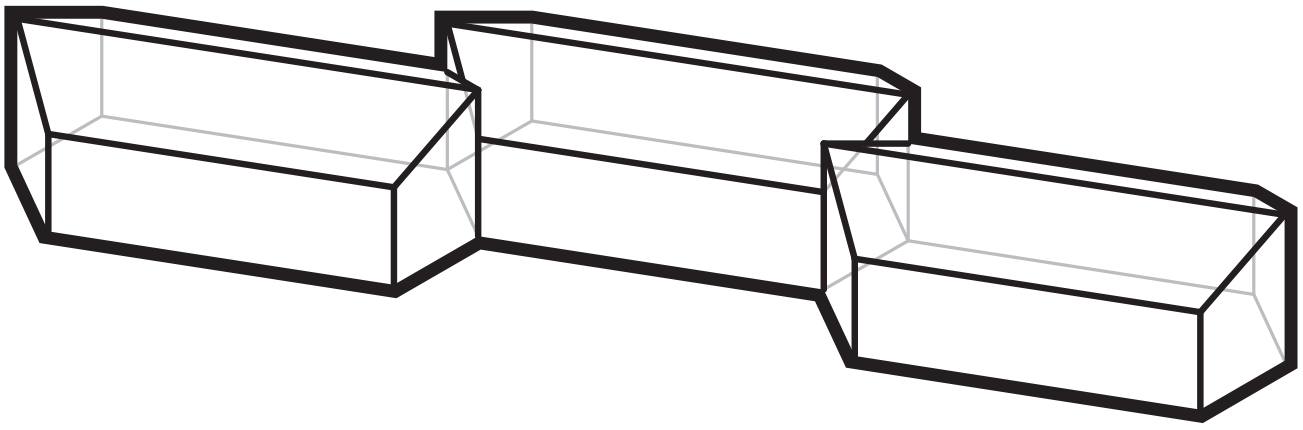

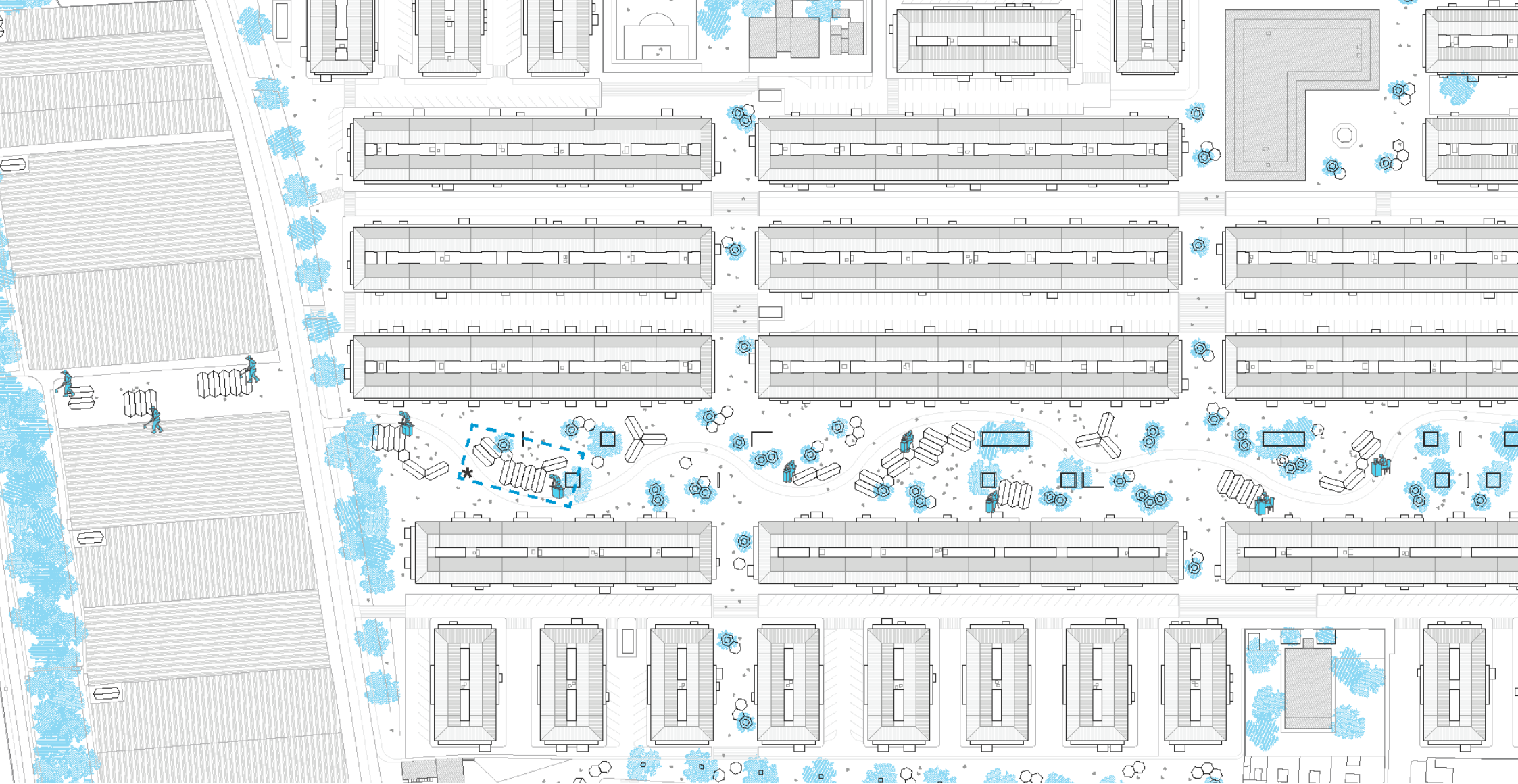

agricultura

ALMACEN
DESCANSO

AULA

TALLER

carpintería

AULA

DESCANSO

TALLER

PINTURA
Y BARNIZ

DUCHAS

BAÑOS

alfarería

DESCANSO

EXPOSICIÓN

COCCIÓN

TALLER

ALMACEN

AULA

costura

ALMACEN

TALLER

EXPOSICIÓN

DESCANSO

AULA

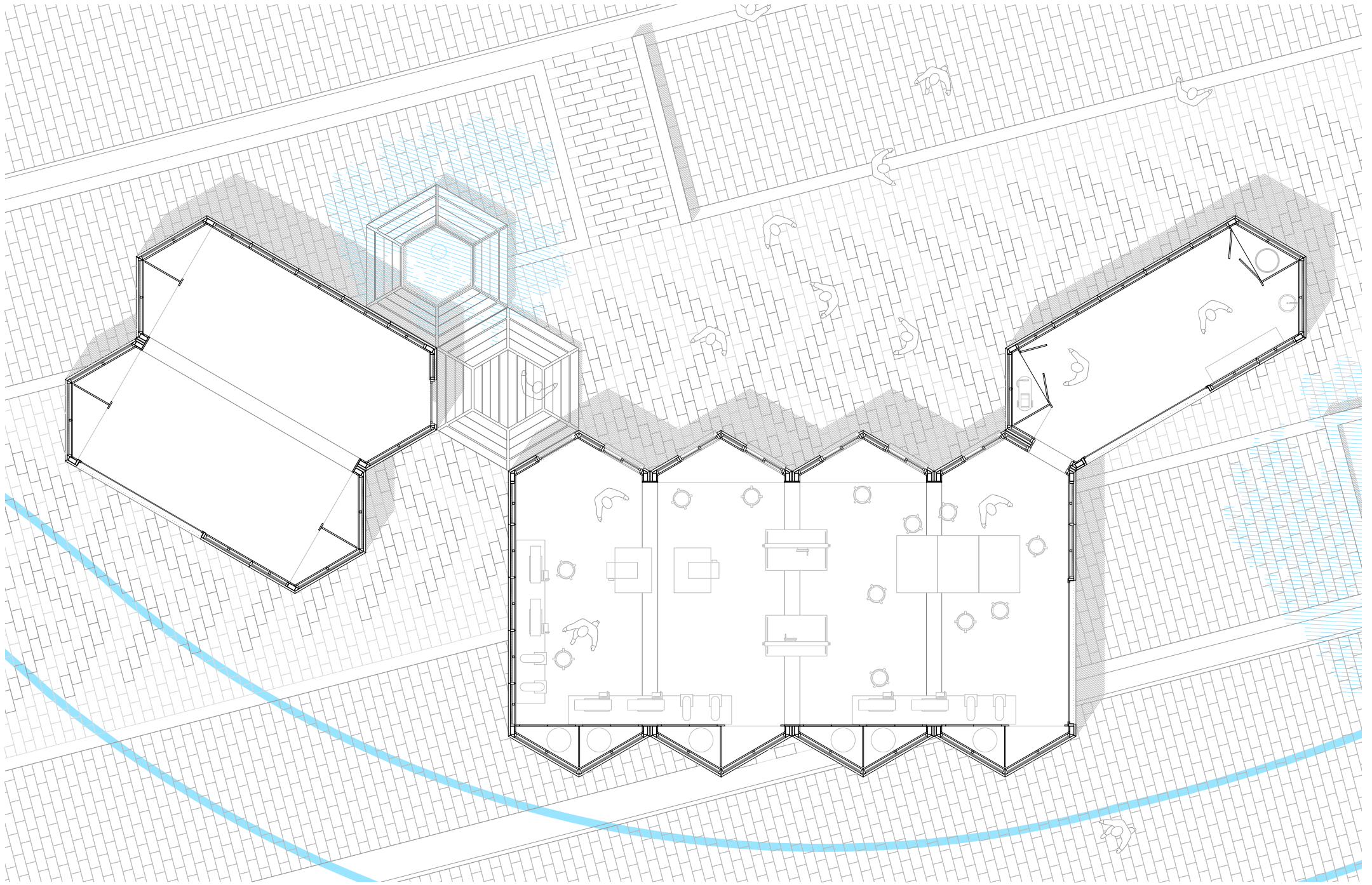





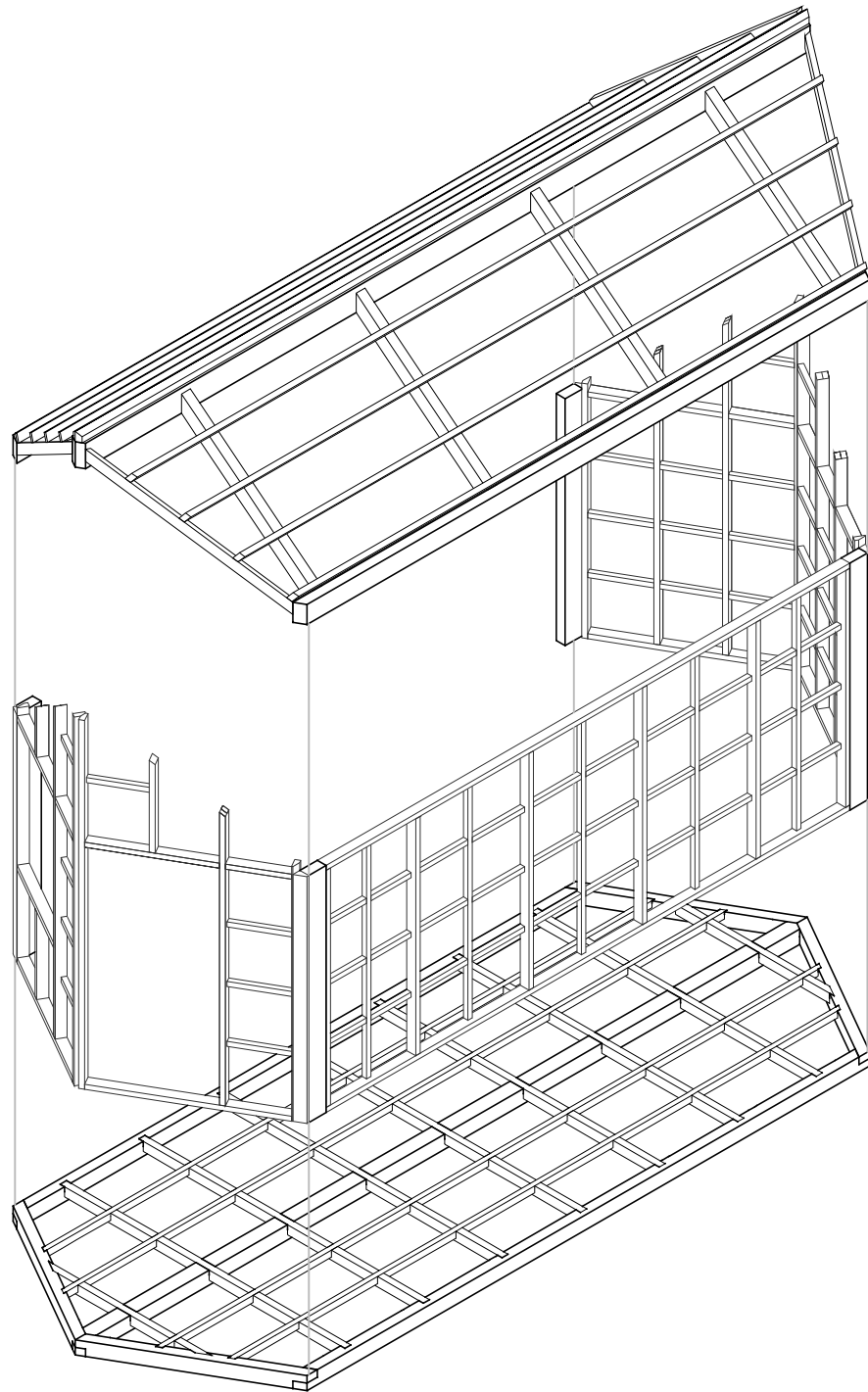

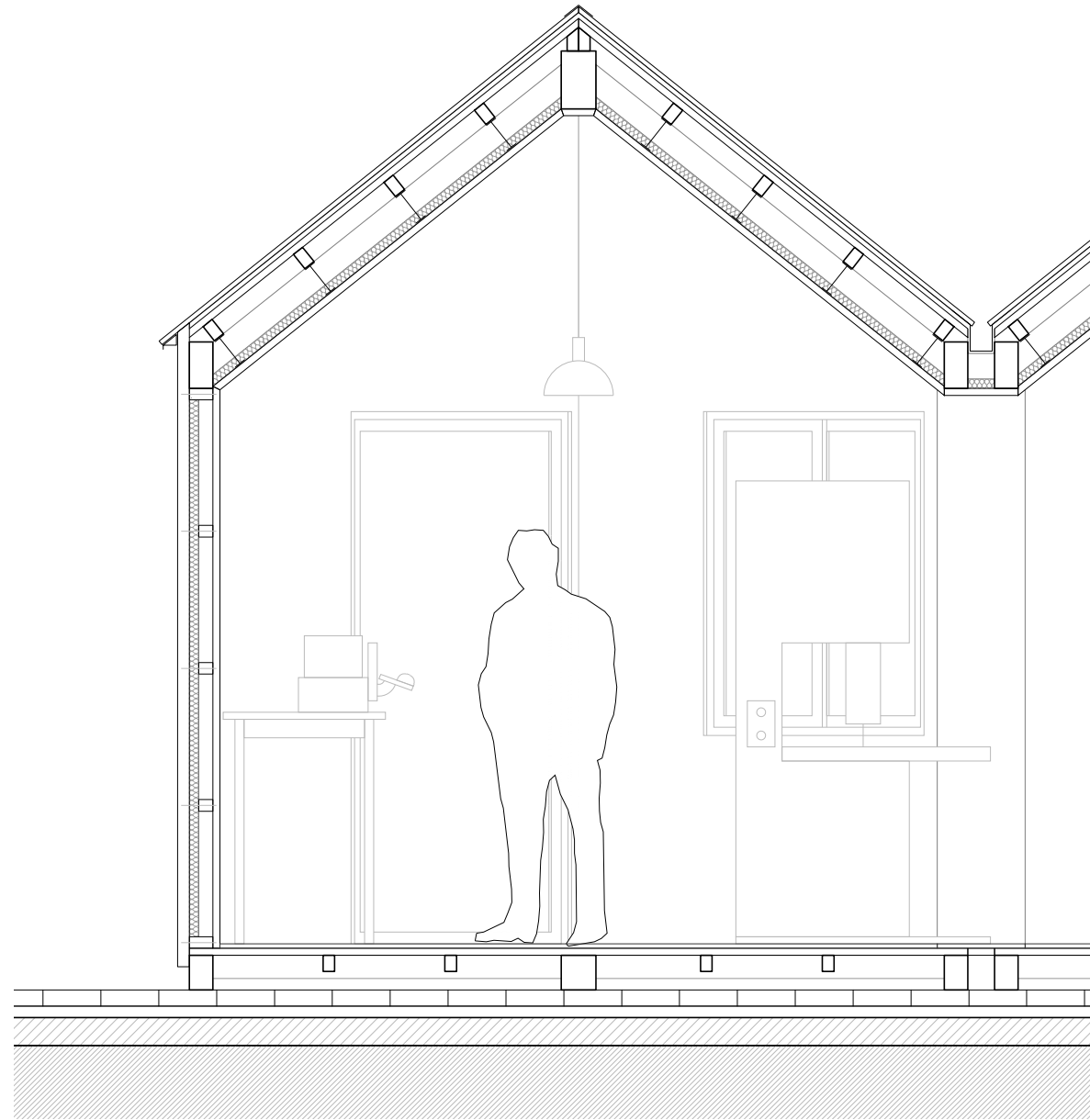



Casa Garoza. Herreros Arquitectos.

3. Infección Positiva.

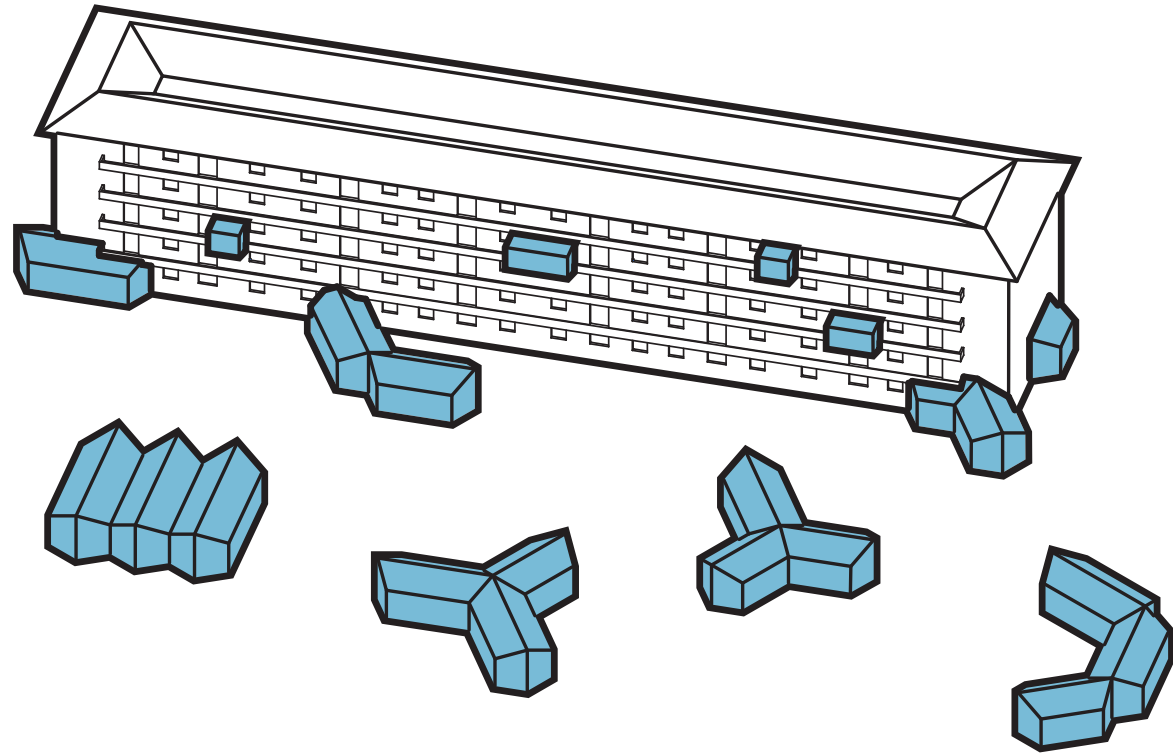



“Si probamos a caminar a lo largo de una playa justo por donde las olas se deslizan entre la tierra y el océano, nos sentimos complacidos de un modo imposible de lograr con el contacto de uno sólo de estos dos grandes elementos. Allí entre los dos, en ese territorio intermedio, no hay nostalgia de ninguna alternativa. La arquitectura, si quiere cuidar a sus habitantes, debería extender esa estricta frontera, ocuparse de suministrar ese lugar intermedio necesario para el hombre y las cosas reales a través de la construcción, desde la escala de la casa hasta la de la ciudad.”

Aldo Van Eyck.

Paseando por la Orilla. Alicia Grau.

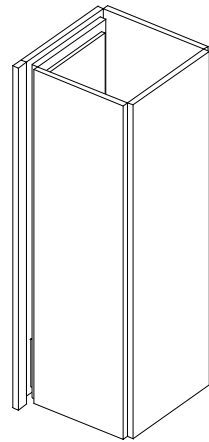

Comedor de Verano.

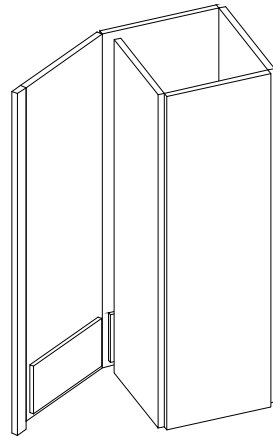

Comedor de Verano.

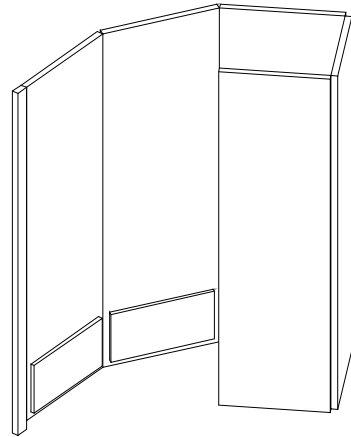

Comedor de Verano.

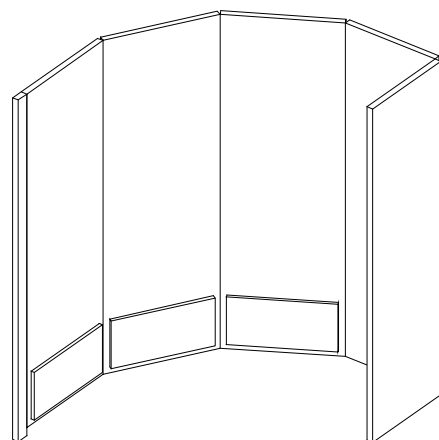

Comedor de Verano.

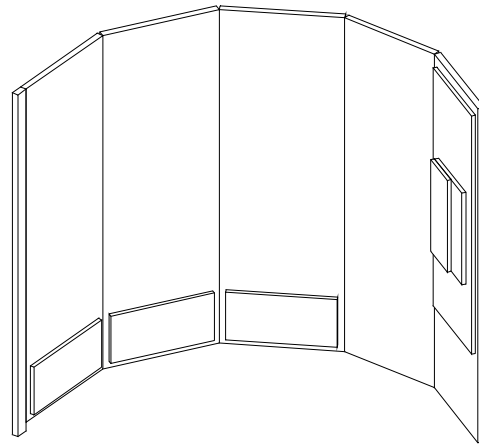

Comedor de Verano.

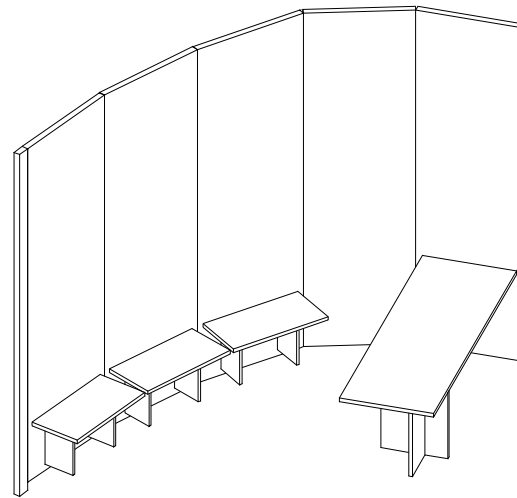

Comedor de Verano.

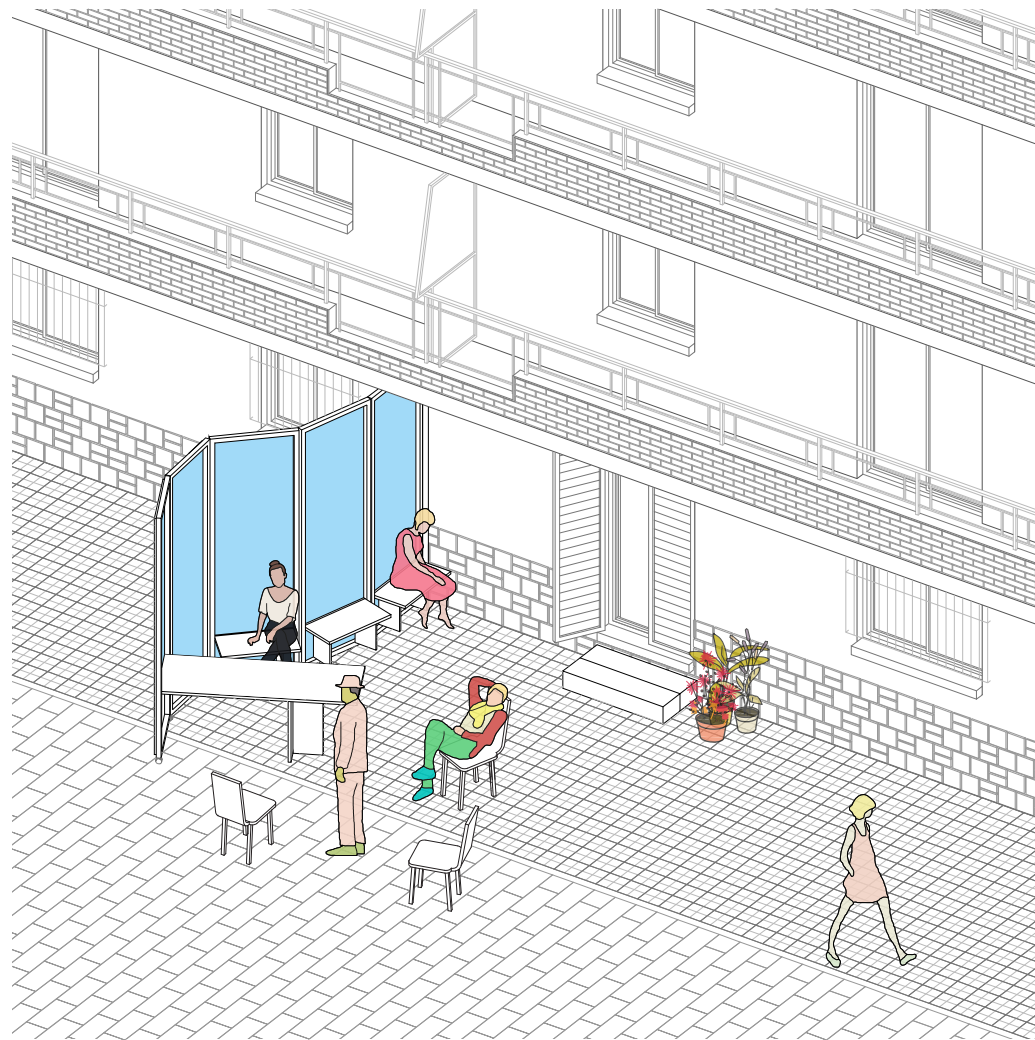

Comedor de Verano.

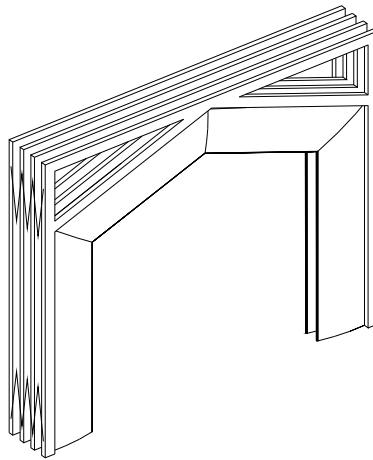

Terraza Plegable.

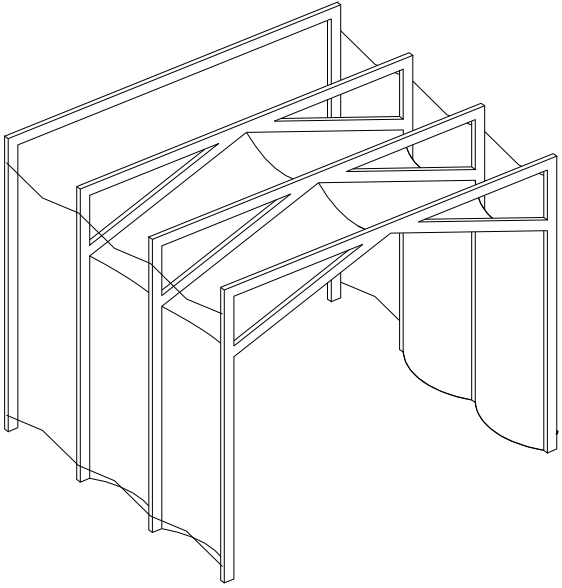

Terraza Plegable.

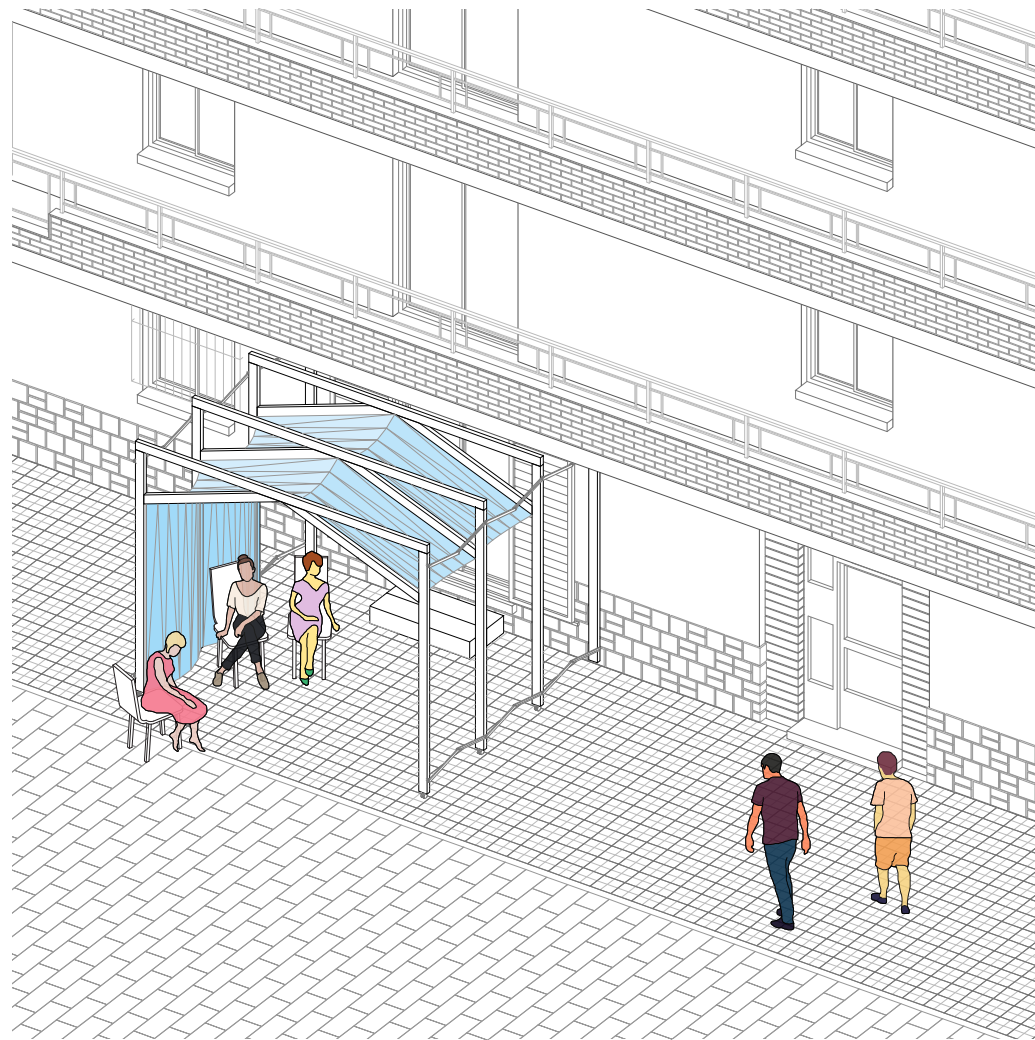

Terraza Plegable.



Célula Ventanosa. J. L. Chanéac.



Arribafrente. Hector Zamora.



Andamios. Recetas Urbanas.



Casa Insecto. Recetas Urbanas.

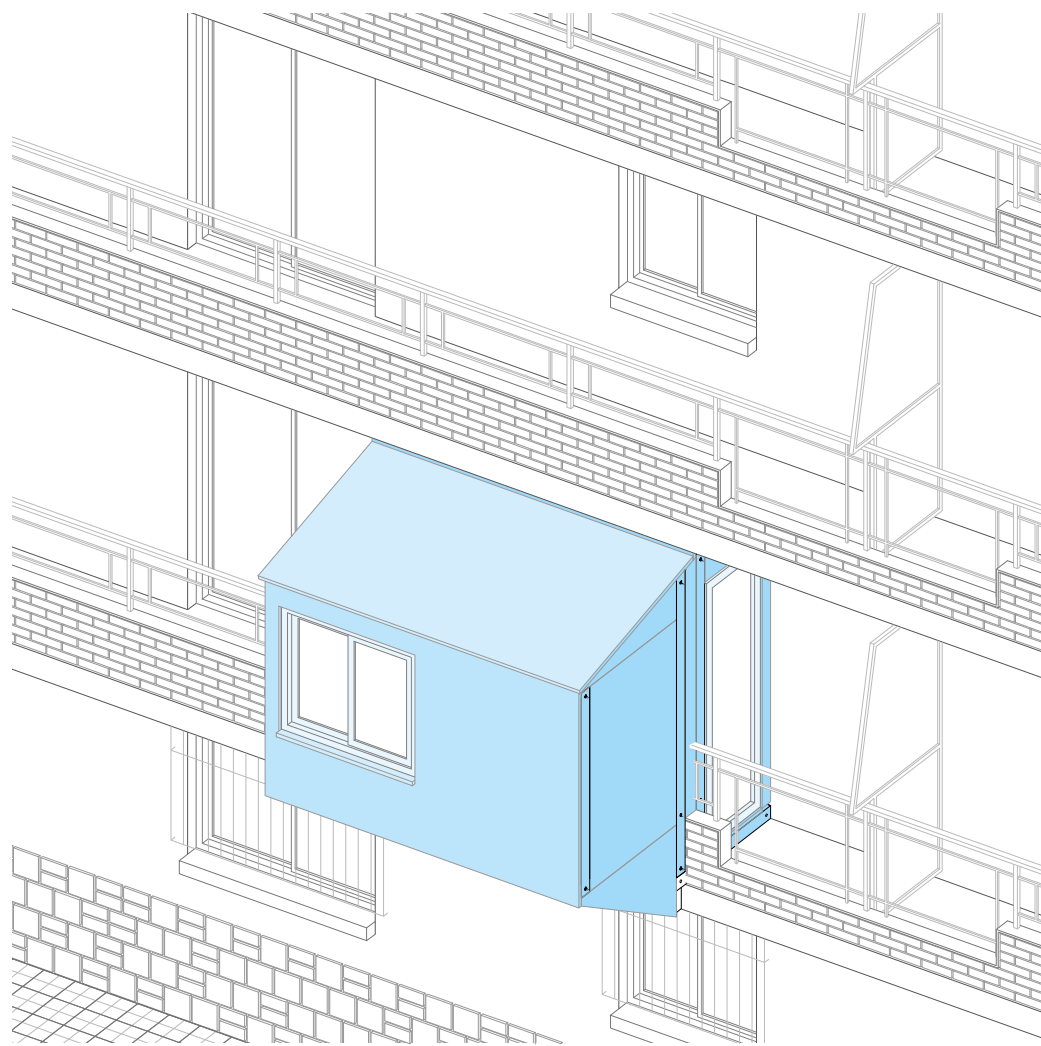

Habitación Satélite.

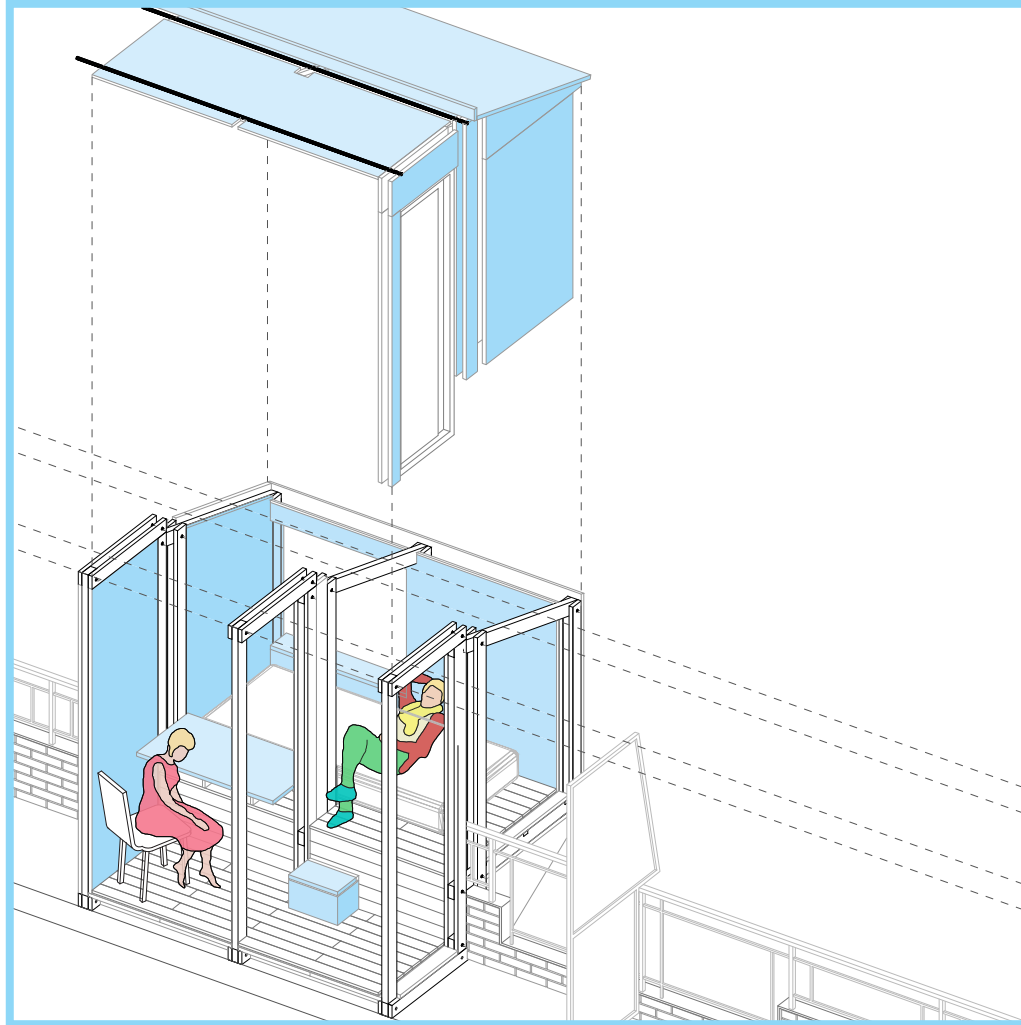

Habitación Satélite.



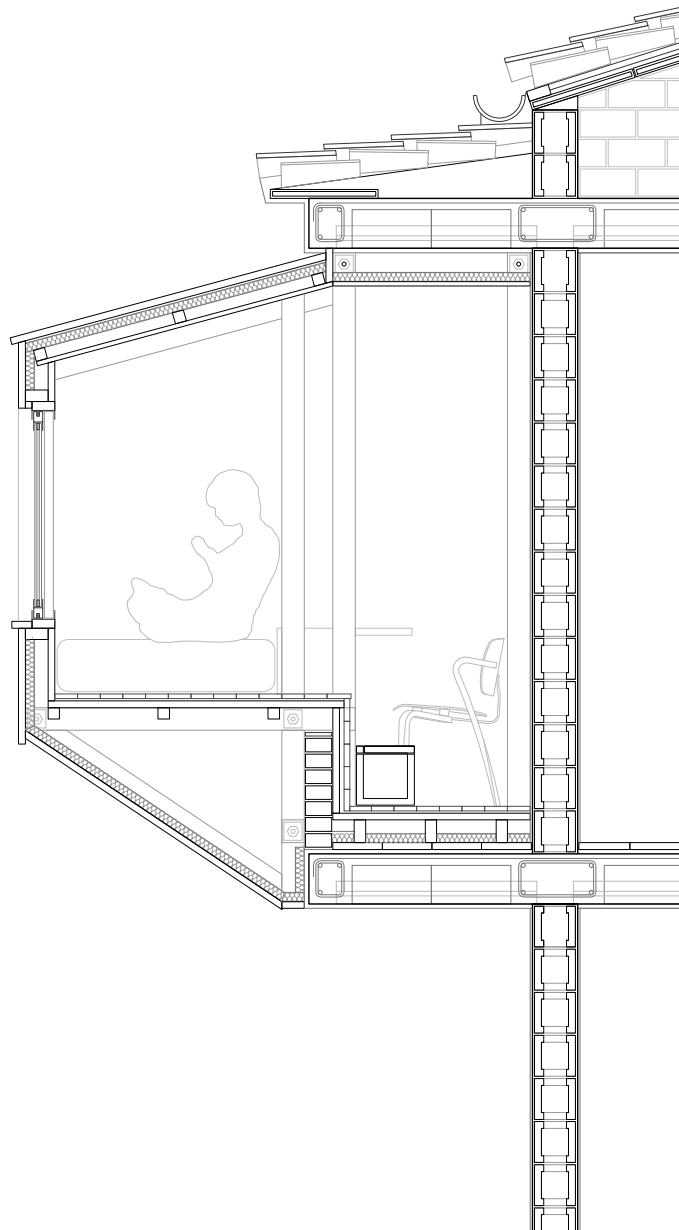

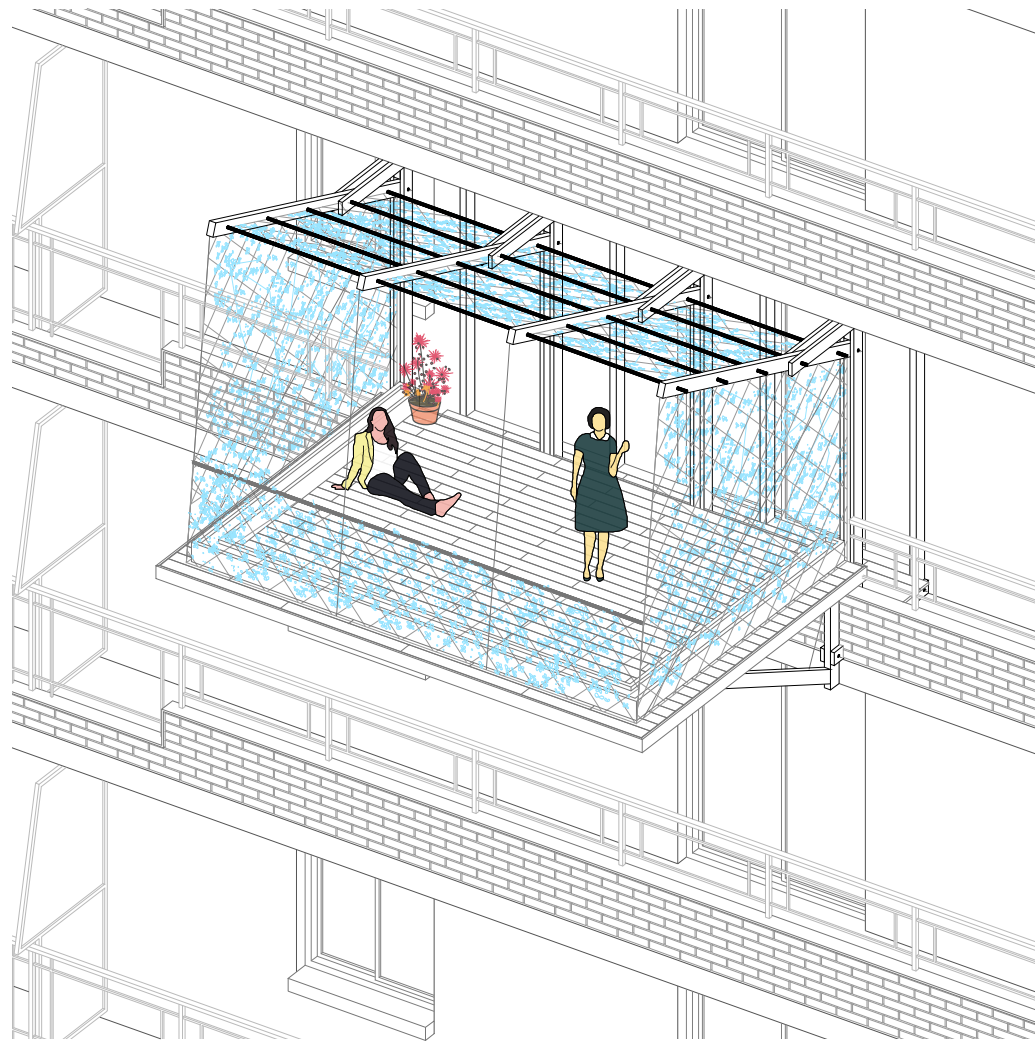

Terraza Colgante.

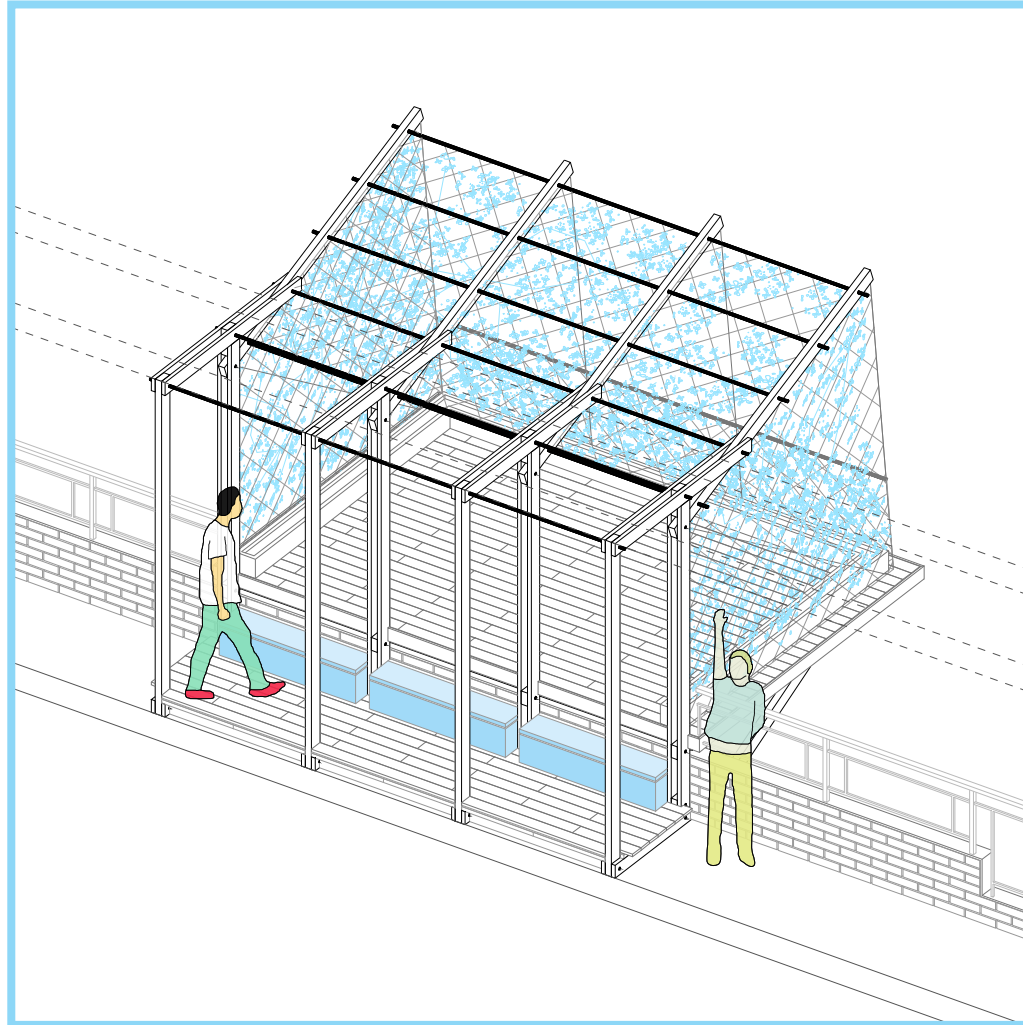

Terraza Colgante.

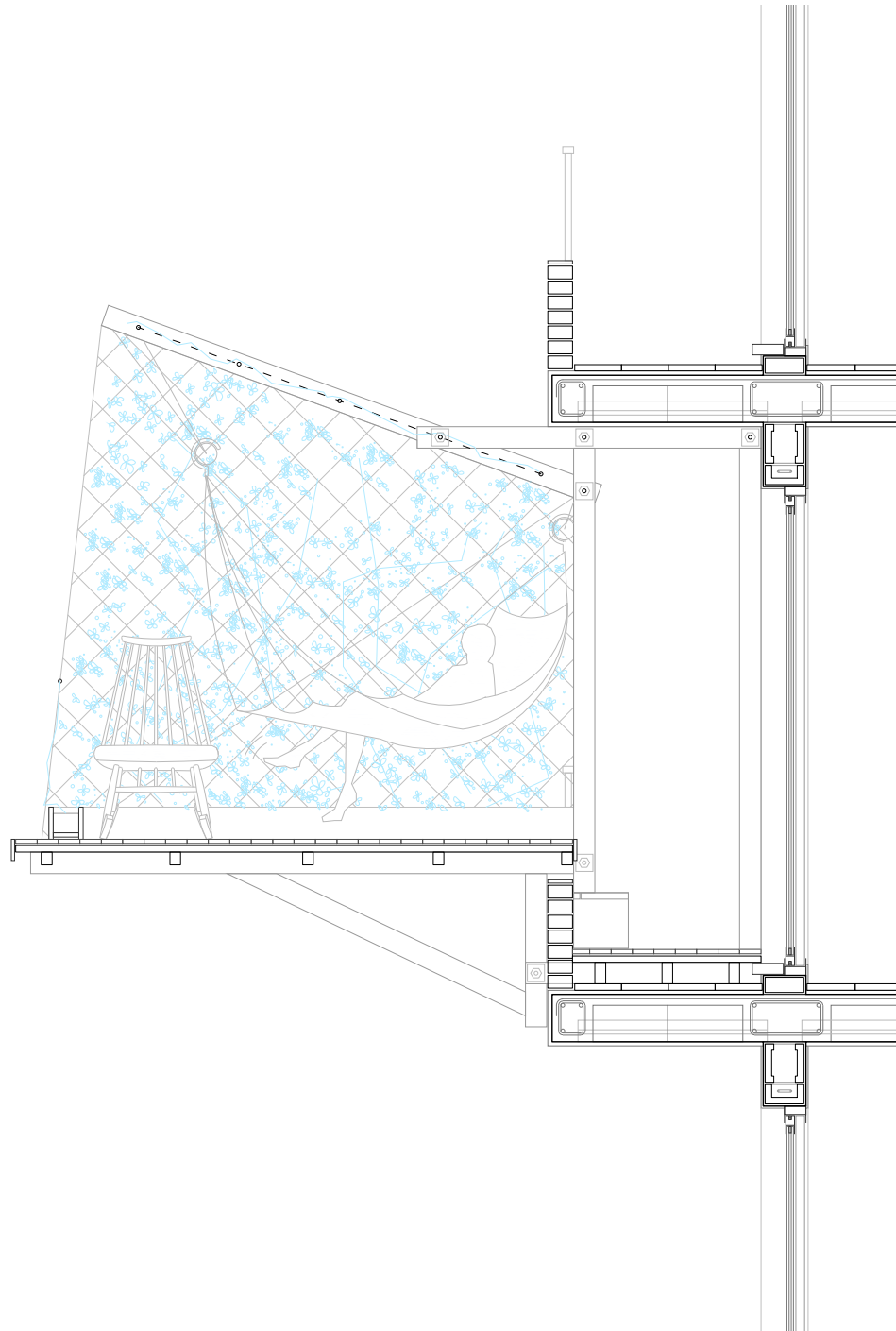

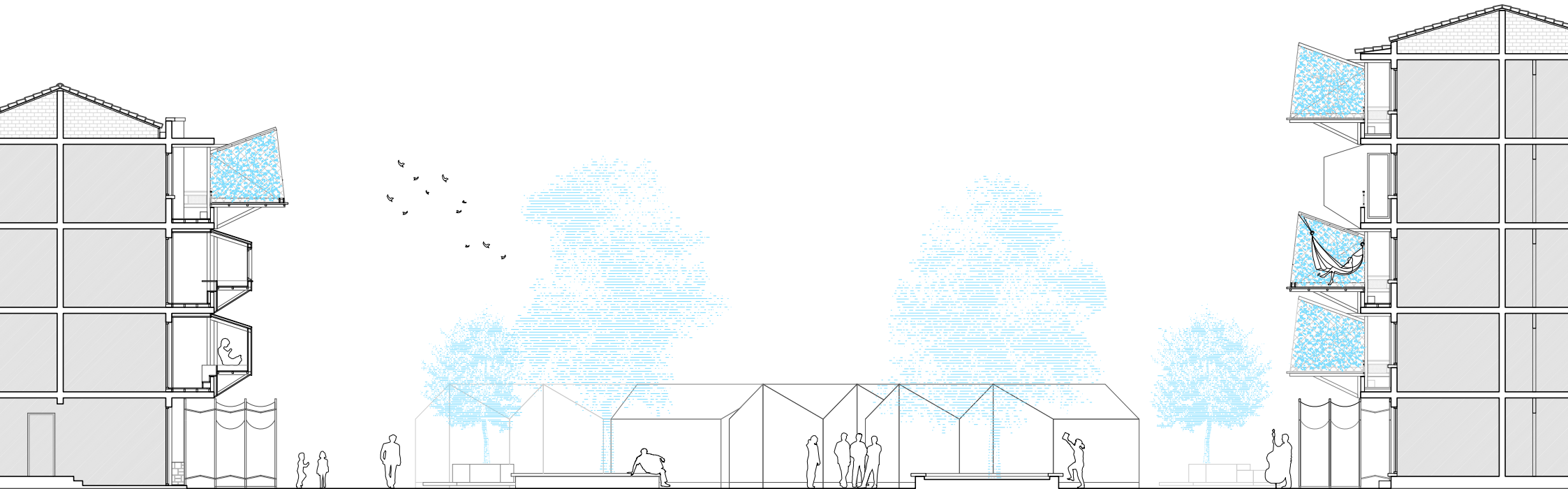



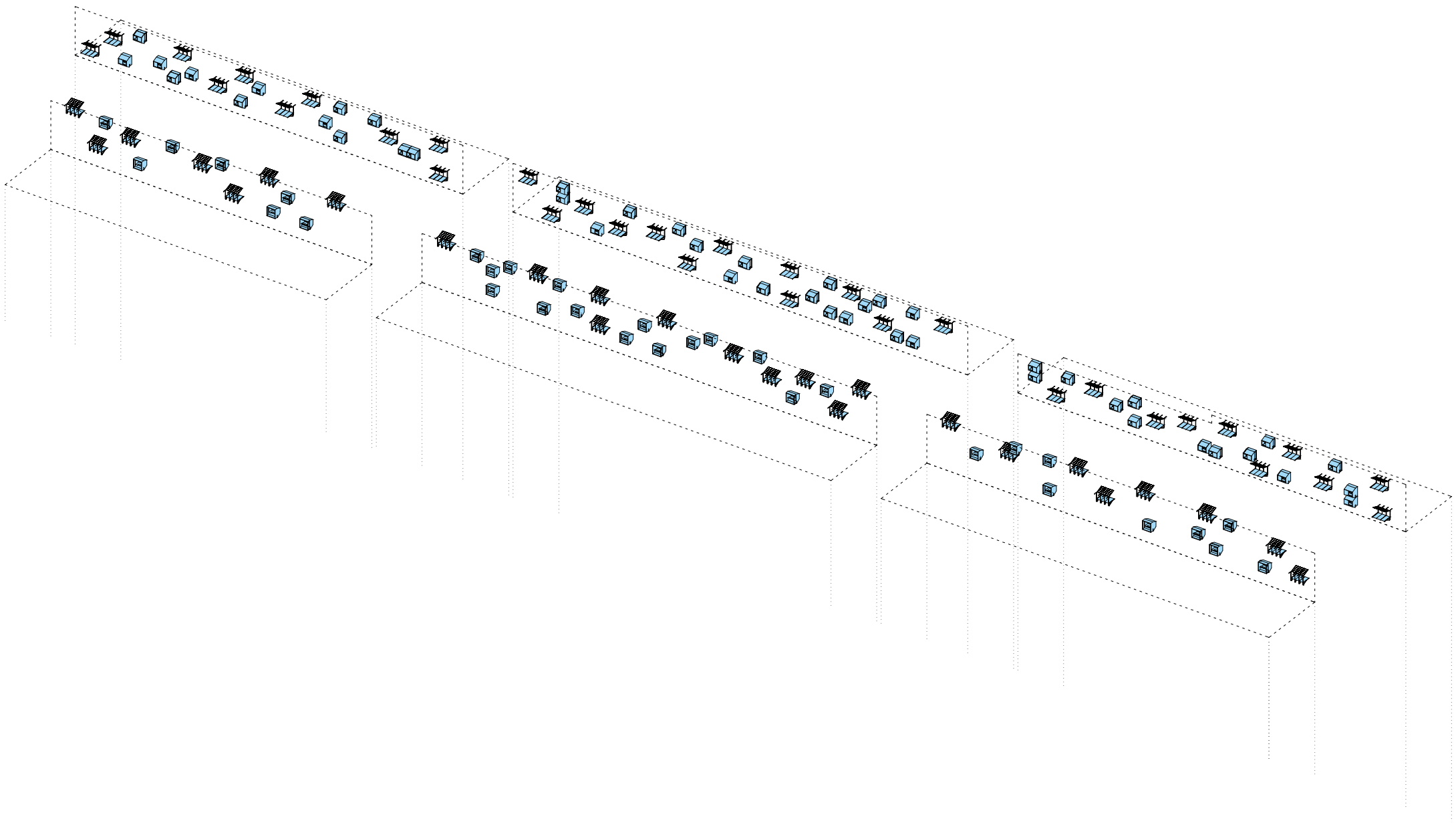

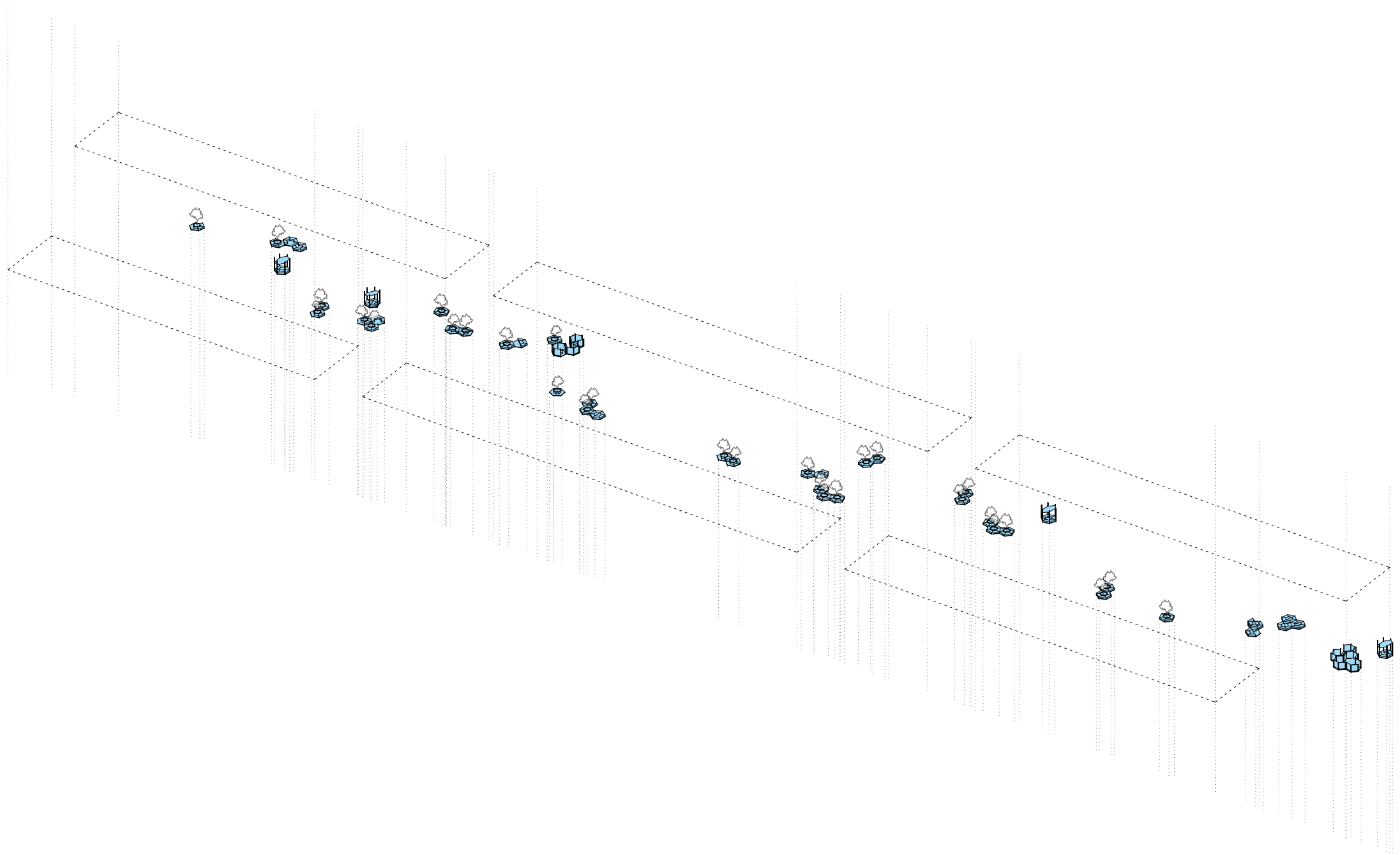

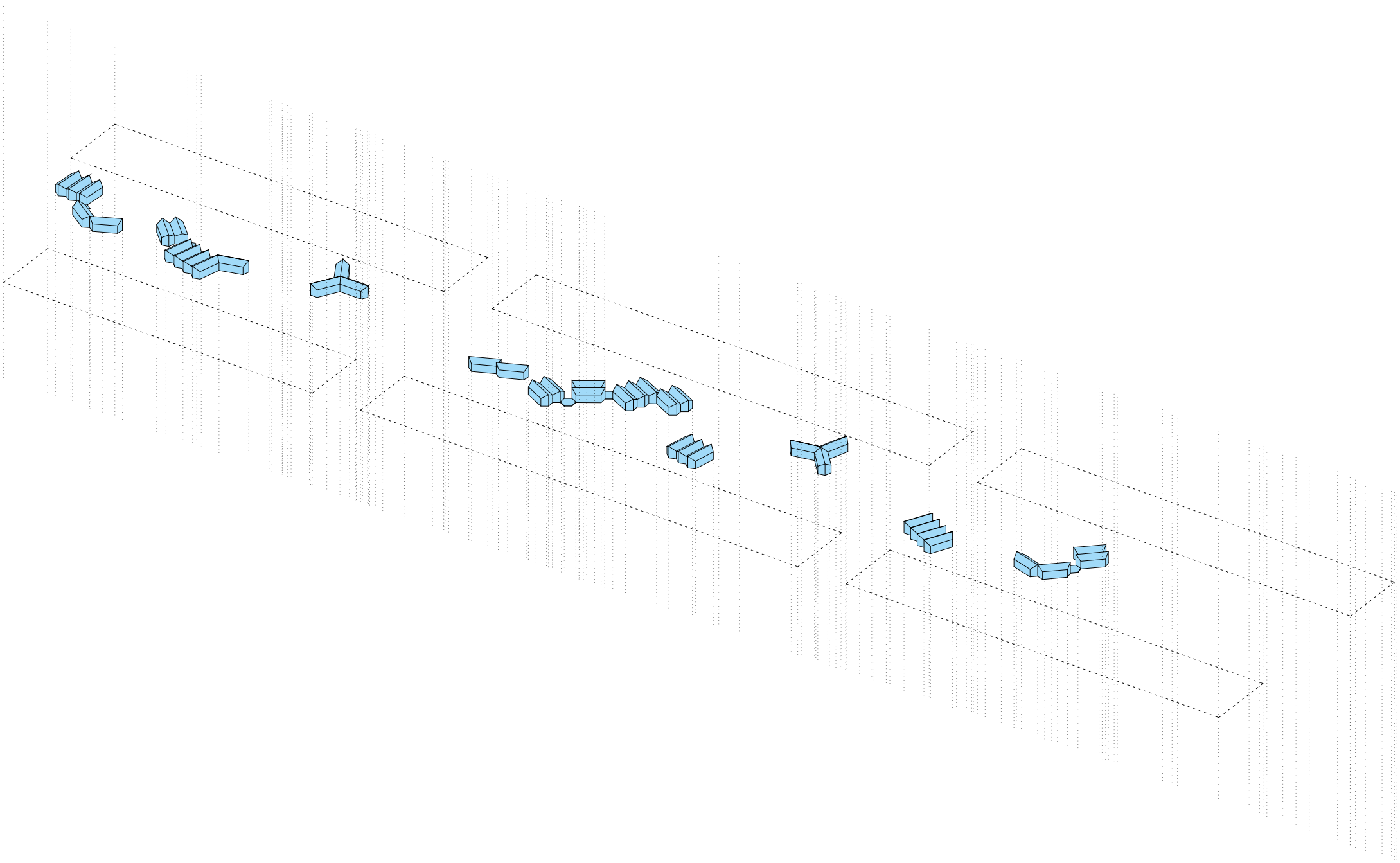

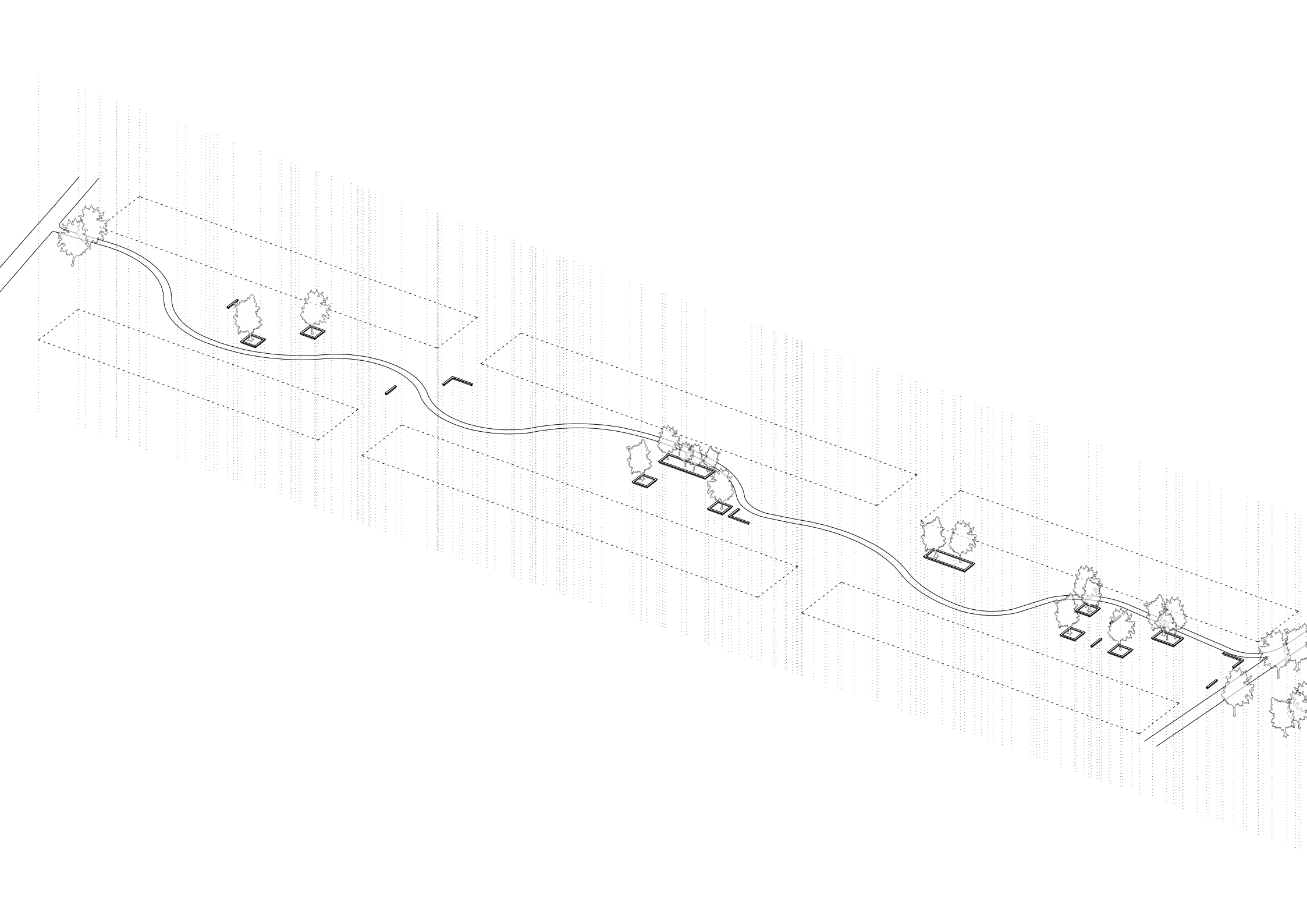

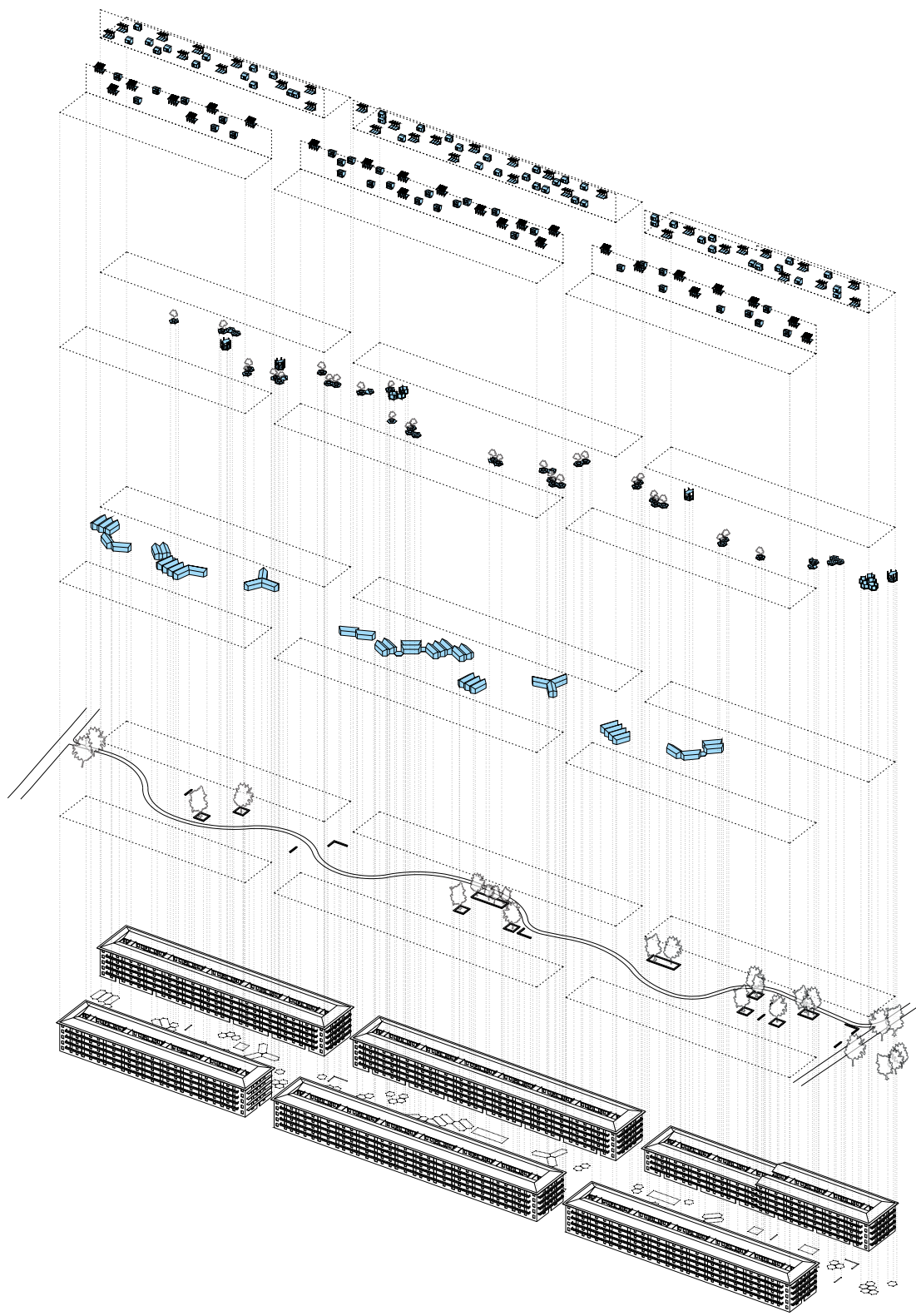

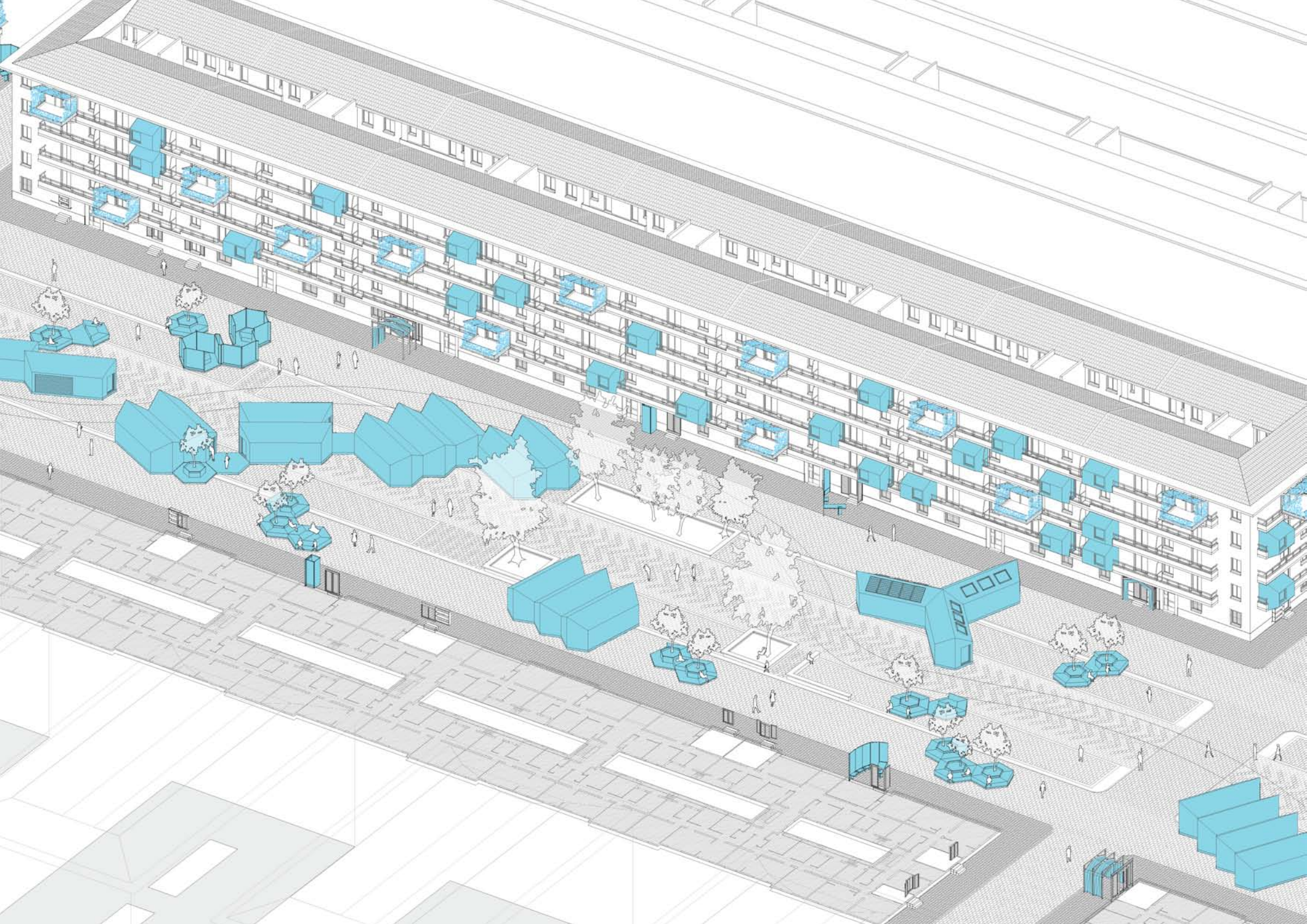

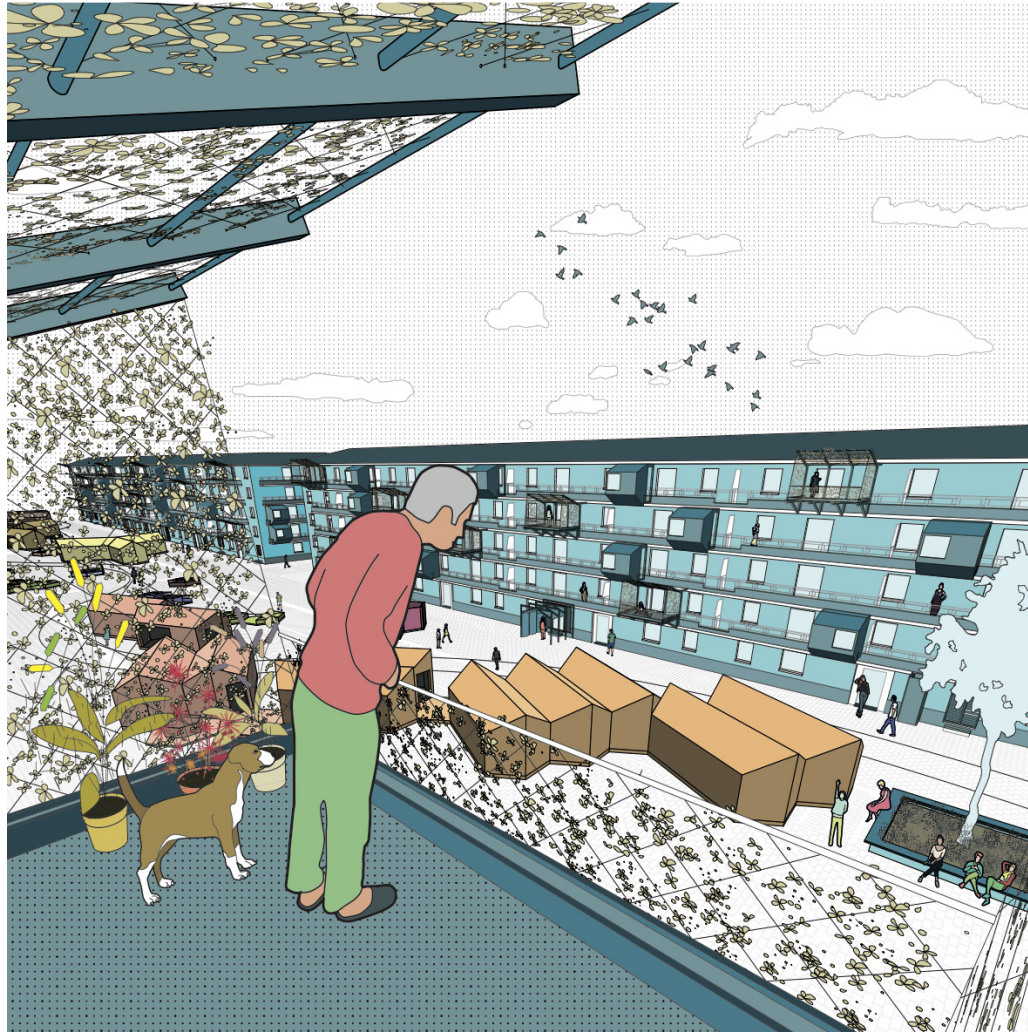

A todos los que lo habéis hecho posible...

MUCHAS GRACIAS

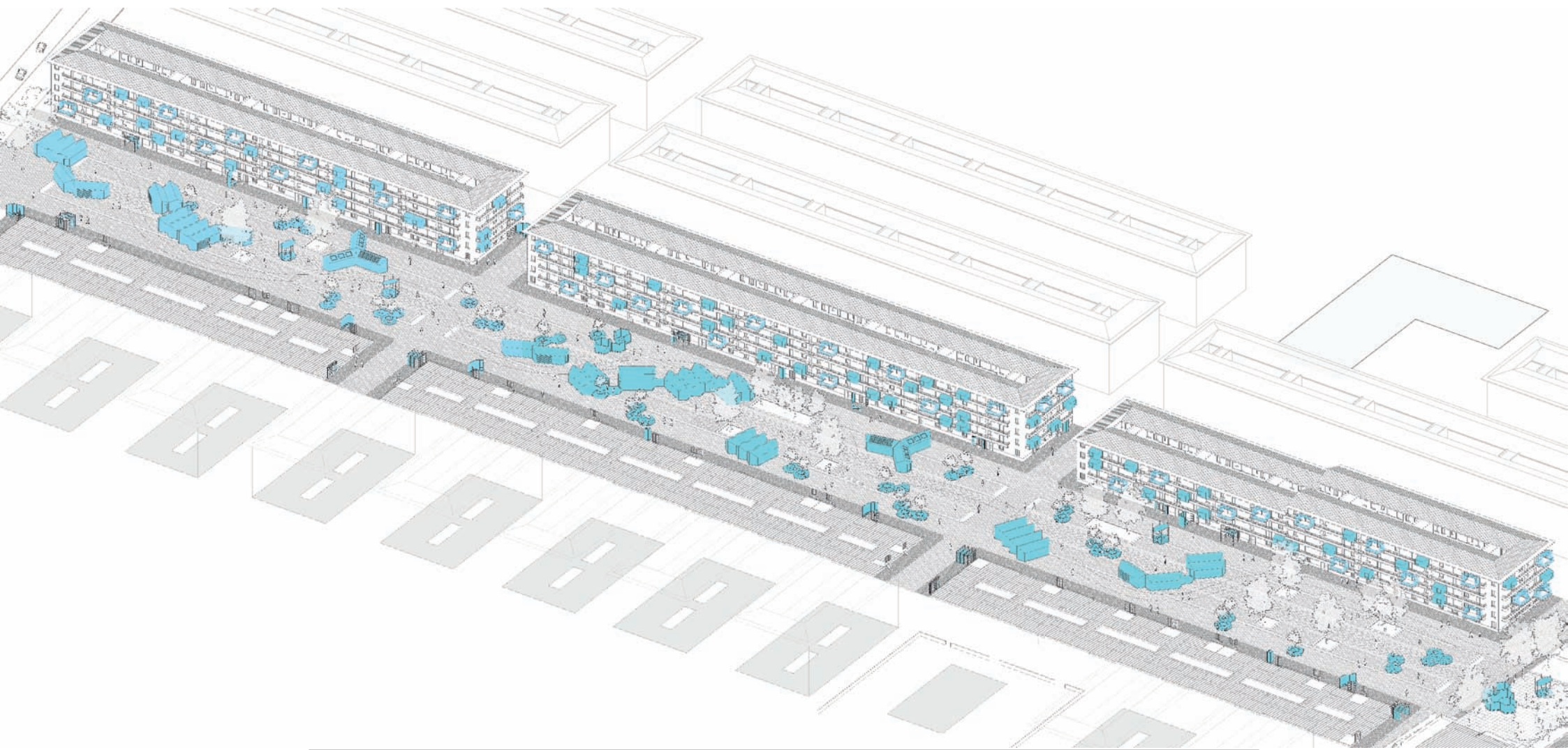

Density. Parque Alcosa, Alfafar. Valencia
Alejandro Espallargas Omedas
PFC taller H 2012/2013