

Computational Structural Form Finding and Optimization of Shell Structures

Andrew BORGART*, Lonneke TIGGELER^a

*Faculty of Architecture, Delft University of Technology
Julianalaan 134, 2628 BL Delft, The Netherlands
a.borgart@tudelft.nl

^a Faculty of Architecture, Delft University of Technology
Julianalaan 134, 2628 BL Delft, The Netherlands

Abstract

The purpose of this research is to analyze the structural behaviour of shell structures by studying the way (applied) loads naturally flow through shell structures to their supports and relating this flow off forces to the shell geometry. To unlock this secret will give a fundamental understanding of the behaviour of shell structures and thus the means to design these with form efficiently and elegance. Shells have geometrical and structural properties, which have a close relationship, and determine its structural performance. The newly developed thrust network analysis [1] lays a direct relation in a graphical way between the geometry of a shell and possible funicular solutions under gravity loading, which gives understanding and provides the means for developing new shapes. The “rain flow” analysis [2] makes the relation between the shell geometry and the flow of loads applied to its surface. Similar with the flow of shear forces in plates in bending the “rain flow” analysis gives the relationship between the initial curvatures of the shell surface geometry and the curvatures along the shell’s surface which represent the load path of the flow of forces of the shell and the internal forces. By combining these algorithms and analysis methods, a further understanding of the form force relationship of shells can be obtained. This unified approach is the basis for a new computational method for form finding and optimizing shell structures.

Keywords: Shell structures, load path, force network, geometry shell, curvature, form-force relationship.

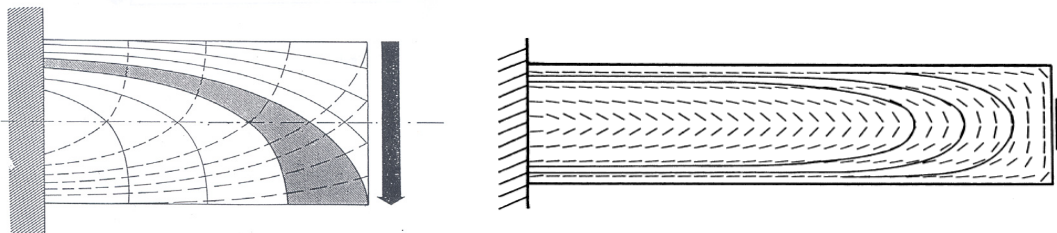

Figure 1: Principle stresses trajectories (left) and load path of cantilever (right picture: courtesy Kelly/Tosh [4])

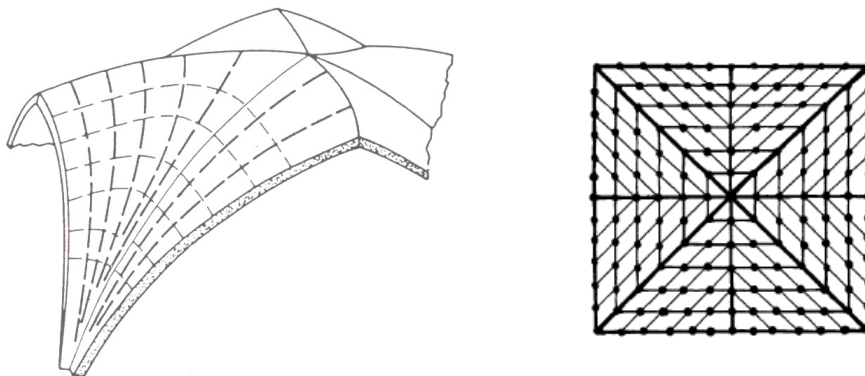

Figure 2: Principles stress trajectories (left) and a force network of a groined vault (right picture: courtesy O'Dwyer [3])

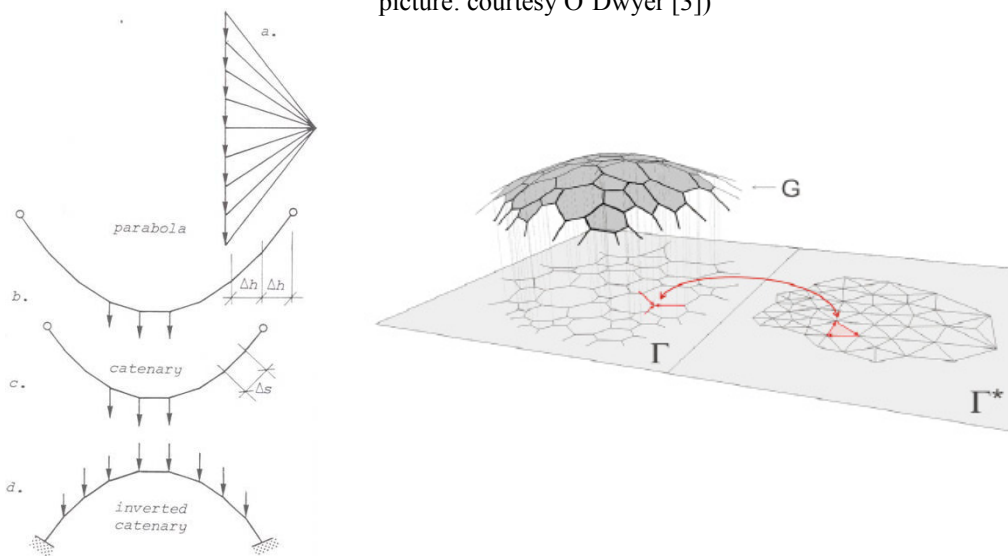

Figure 3: Force polygon and form diagram of cables and arches (left) and a thrust network grid (right picture: courtesy Block/Ochsendorf [1])

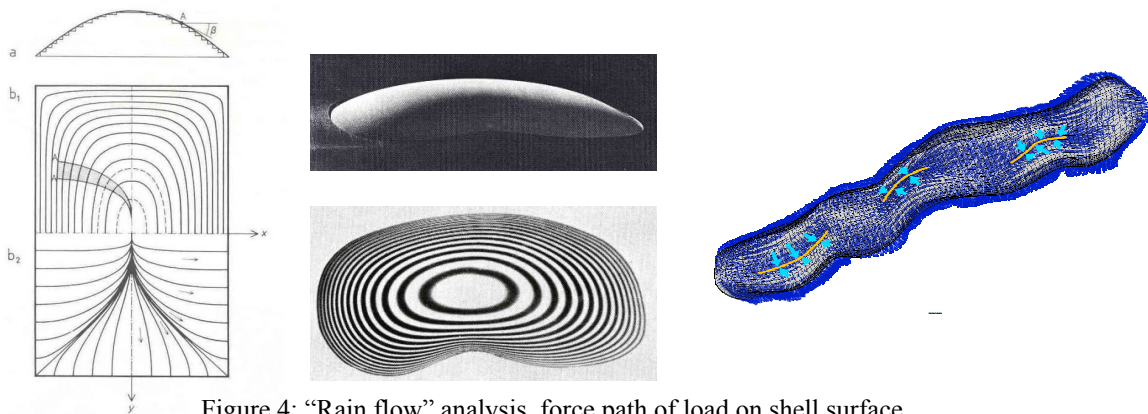

Figure 4: "Rain flow" analysis, force path of load on shell surface

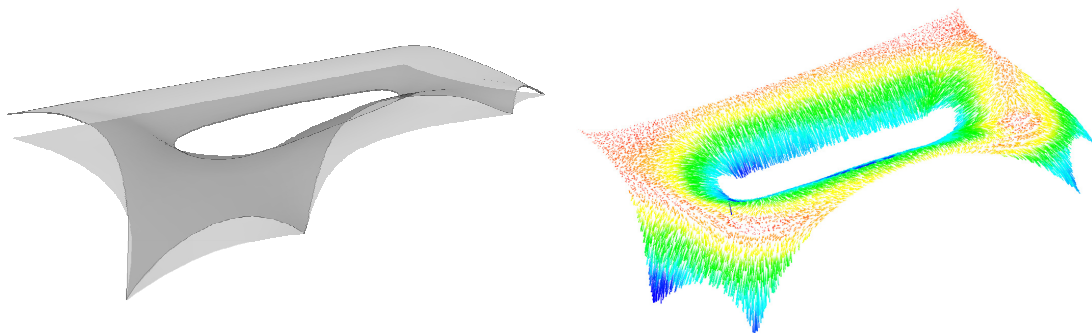

Figure 5: "Rain flow" analysis used for designing optimum shell structure

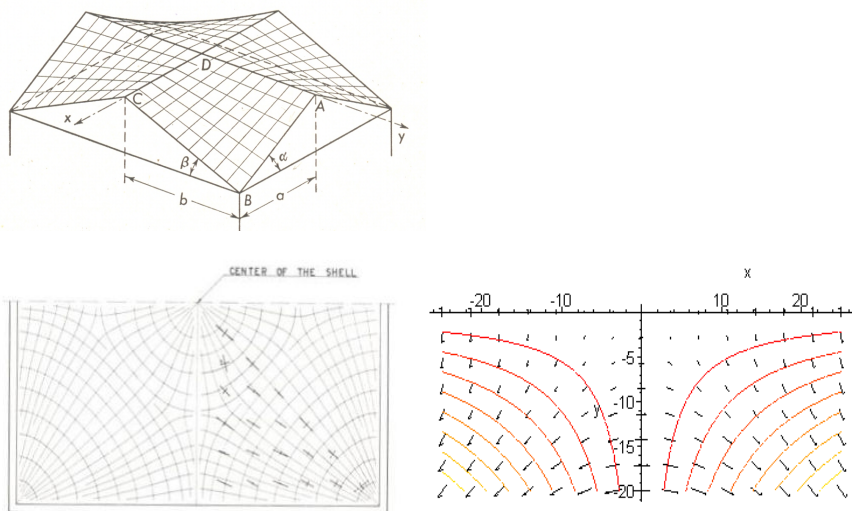

Figure 6: Principle stress trajectories (left) and "rain flow" analysis of hyper shell (right)

1. Introduction

For many years shell structures have excited interest, especially their seemingly mysterious state of equilibrium in relation with their form. Thin shells spanning long distances are a sight of beauty. However, just as Professor Ekkehard Ramm called shells the prima donnas of structures, the designing of these gracious structures has many pitfalls. A wrong geometry or edge shape can totally ruin the shell's structural behaviour and the shell performs poorly resulting in a failed design.

Many scientists over the years have formulated very useful shell theories for analytically calculating the internal forces and stresses in the shell. The theories are usually very mathematical but give little insight in the relation between the stresses and the shell's geometry and are nearly always only applicable to shells with simple mathematically described geometries. Some scientists, like Heinz Isler, have done physical experiments on shell structures to try to disclose the relationship form-force. Since the arrival of 3D computer programmes and the use of architects to explore designing irregular curved surfaces, most of the shell theories fail to provide analytical solutions and thus the structures are calculated numerically. Hereby the relations who are enclosed in analytical solutions are lost, making the relationship between the stresses and the geometry even less insightful. This lack of insight makes designing (irregular shaped) shells, which are not always real shells in the sense that the predominant part of the loads are carried by in-plane normal forces but are just curved surfaces loaded in bending, even more difficult for the designer and engineer.

Graphical solutions such as force polygon and form diagram for line structures such as cables and arches (see fig. 3) and force network / thrust network for surface structures as shells give the designer at least insight in the relation between the internal forces and loads and the geometry of the shell as far as it concerns the magnitude of the forces and the form of the structure. What even graphical solutions do not reveal is why a particular curve or an entire curved surface or the number and location of the supports result in certain internal forces and support reactions. This mystery is waiting to be discovered.

2. Relation load path – force network

The principle force path of an applied load of a shell is not easy to determine, because most shells are highly indeterminate. The calculated, in most cases with the help of finite element methods, principle stresses and their trajectories are not exactly similar load path [4], see fig. 1. This means that to determine a force network for analysing a shell's behaviour with or without making of finite element calculations several possible load paths have to be considered [3], see fig. 2. The best result possible is numerous possible states of equilibriums within the thickness of the shell's surface or defined envelope. By adding the force network analysis the concept of duality between geometry and the in-plane internal forces of networks, similar to the duality of the force polygon and form diagram for line structures, it is possible to have a direct graphical relation between the force network and its possible solutions [1], see fig. 3. However, the "real" solution is not provided by this

method, because of the highly indeterminate nature of shell structures, which makes it impossible without the finite element method to calculate the correct internal forces given a particular situation.

By introducing the “rain flow” analysis [2], see fig. 4, it would be possible to determine the unique load path of a shell given a certain load (see fig. 7). This method has proven useful in the design of shells with optimum shell behaviour with practically no bending, see fig. 5. The hypothesis of the “rain flow” analysis is; “like a rain flow loads will flow along curves with the steepest ascent on the shell surface to its supports” (see fig. 6) and is linked to the load path method as described in [4].

3. Relation load path - curvature

The “rain flow” analysis points out that the flow of forces or load path are a function of the curvature of the shell’s surface. However, the notion of shell curvature is not a straightforward one. A curved surface, which forms the shell’s geometry, has intrinsic properties and extrinsic properties. The intrinsic properties depend only of measurements of length in the surface itself while the extrinsic properties (such as principle curvatures, see fig. 8), which are more comely used in engineering, involve measurements in three-dimensional space [6]. The extrinsic curvatures also depend on the global and local coordinate systems see fig. 8. For the “rain flow” analysis, we have to consider the extrinsic curvature set in the global coordinate system.

However, by studying the intrinsic properties of surface it might lead to the desired relation between force flow (load path) and the shell’s surface geometry.

4. Relation force network - curvature

As can be seen with experiments with hanging models such as deformable cloth naturally shaped by gravity loading (see fig. 9), the load path and thus its unique force network are inseparably linked with the models gravity shaped surface and its curvature. This means that the unique solution of a shell’s force network under a specific loading condition is the result of the curvatures, which define the geometry of the shell surface.

The Gaussian curvature of a point on a surface before and after deformation of the surface, for example by loading, remains equal [5] (see fig. 9), but could change the load path and therefore its unique force network. In addition, it is the curvature of a surface that determines its state of indeterminacy. By solving the relationship between curvature and load path the unique force network can be derived and thus the problem has been solved: a qualitative and quantitative relation between form and force.

A fundamental understanding of the geometry of distortion of curved surfaces in relation to its load path and unique force network would also shed light on the geometric non-linear behaviour (large displacements) and buckling of shell structures.

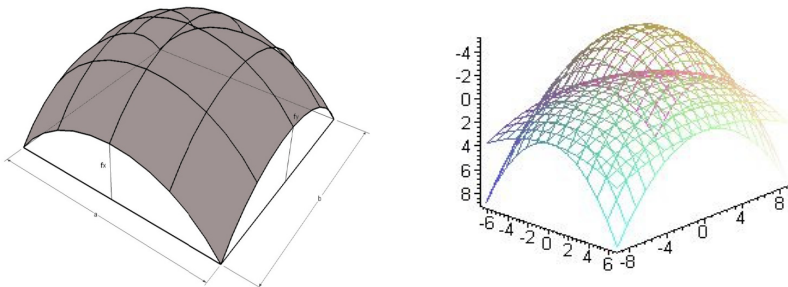

Figure 7: Elpar shell (left) and surface with unique force network solution (right)

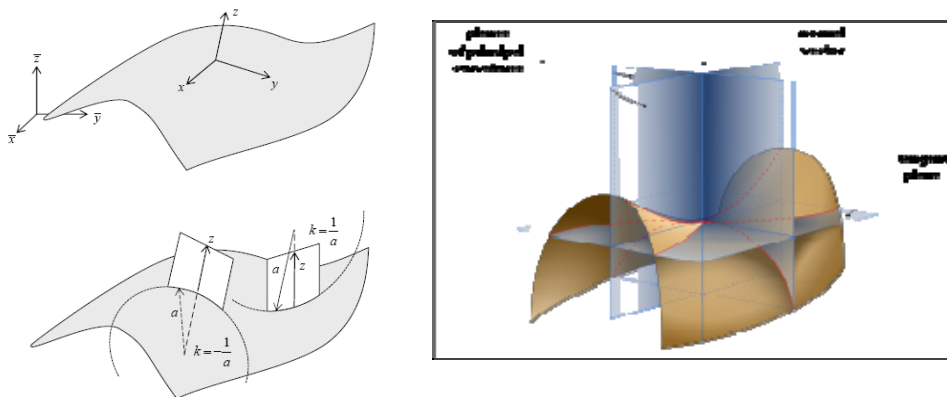

Figure 8: Curvatures of a surface (left) and principle curvatures (right)

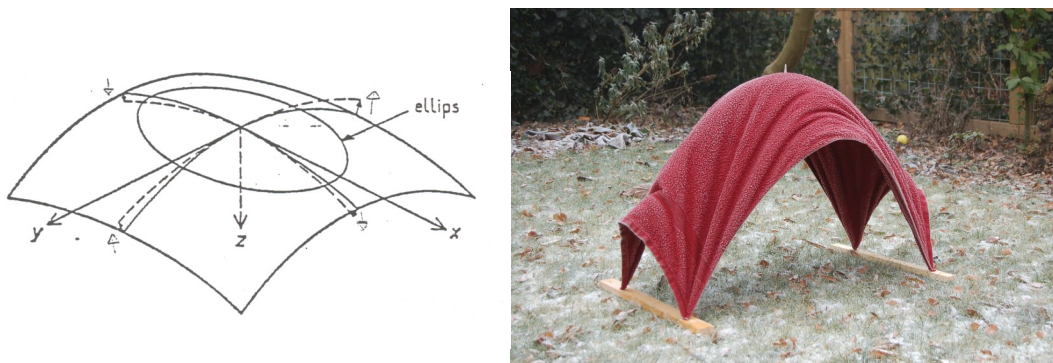

Figure 9: Geometry of distortion of curved surfaces (left) and hanging model (right)

5. Conclusions

In this proposition paper a link is suggested between the geometry of a shell's surface via its curvature and the load path and force network, which are a result of loading of the shell structure. In this link lies the probable solution for unveiling the relation form – force of shells, which will help architects and engineers really understand the structural behaviour of shells and could help design elegant and optimum shell structures.

The proposition will be the focus of studies the coming years to prove this hypothesis.

References

- [1] Block P., Ochsendorf J., Thrust Network Analysis: A New Methodology for Three-Dimensional Equilibrium. *Journal of the International Association for Shell and Spatial Structures*, Vol. 48, No. 3, 2008, pp. 167-173.
- [2] Borgart A., The Relationship of Form and Force in (irregular) Curved Surfaces. *Proceedings of the 5th International Conference on Computation of Shell and Spatial Structures*, Salzburg, 2005
- [3] O'Dwyer D., Funicular analysis of masonry vaults. *Computers & Structures*, Vol. 73, No. 1-5, 1999, pp. 187-197.
- [4] Kelly D.W., Tosh M.W., Interpreting load paths and stress trajectories in elasticity. *Engineering Computations*, Vol. 17, No. 2, 2000, pp. 117-135.
- [5] Calladine C.R., Gaussian curvature and shell structures. *The mathematics of surface*, Ed J.A. Gregory, Oxford, Clarendon Press, 1986, pp. 179-196.
- [6] Calladine C.R., *Theory of Shell Structures*. Cambridge University Press, 1983.