

Document downloaded from:

<http://hdl.handle.net/10251/84429>

This paper must be cited as:

Ricchiuti, AL.; Hervás-Peralta, J.; Sales Maicas, S. (2016). (Invited) Cascade FBGs distributed sensors interrogation using microwave photonics filtering techniques. *Optics and Laser Technology*. 77(3):144-150. doi:10.1016/j.optlastec.2015.09.003.



The final publication is available at

<http://dx.doi.org/10.1016/j.optlastec.2015.09.003>

Copyright Elsevier

Additional Information

Cascade FBGs distributed sensors interrogation using microwave photonics filtering techniques

Amelia L. Ricchiuti*, Javier Hervás and Salvador Sales

Optical & Quantum Communications Group, iTEAM Research Institute, Universidad Politécnica de Valencia, Camino de Vera s/n, 46022, Valencia (Spain)

*corresponding author: email address: amric1@iteam.upv.es; tel.: +34 963 877007 88276

Abstract

Systems to interrogate photonic sensors based on long fiber Bragg gratings (FBGs) are illustrated and experimentally validated. The FBGs-based devices are used as quasi-distributed sensors and have demonstrated their ability to detect and measure the precise location of several spot events. The principle of operation is based on a technique used to analyze microwave photonics (MWP) filters. The overall idea beyond this work has been borne out and demonstrated step by step starting from preliminary test that have led to the development of a very-long distributed sensor based on an array of 500 equal and weak FBGs. Firstly, we have demonstrated the feasibility of the MWP filtering technique to interrogate a 10 cm-long high reflectivity ($\approx 99\%$) FBG. Then, a pair of low-reflectivity ($< 6\%$) FBGs has been employed as sensing device. The latter has laid the foundation for the development and implementation of a 5 m-long fiber optic sensor based on 500 very weak FBGs. Spot events have been detected with a good spatial accuracy of less than 1 mm using a modulator and a photo-detector (PD) with a modest bandwidth of only 500 MHz. The simple proposed schemes result cost effective, intrinsically robust against environmental changes and easy to reconfigure.

Keywords - Discrete-time sensors, fiber Bragg gratings, distributed fiber optic sensors, microwave photonics filters.

1. Introduction

Over the years, fiber optic devices and components have become one of the core technologies in a variety of fields due to their advantageous features such as simplicity, small size, light weight, low insertion loss, low cost, and the ability to make multiple distributed measurements along the fiber length. Furthermore, since optical fibers are made of dielectric material, they prove to be non conducting, immune to electromagnetic interference (EMI), chemically inert, spark free and extraordinarily resistant to corrosive surroundings [1]. All these attractive characteristics are highly desirable for remote interrogation from long distance and/or in harsh environments. For these reasons fiber optic based devices have been broadly implemented in many sensors applications.

In the fiber optic sensing area, fiber Bragg gratings (FBGs) have been playing a key role owing to their fast response, high sensitivity, distributed and multiplexing capability of measuring different kinds of physical and mechanical parameters [2]. Furthermore, the systems employed to interrogate FBG sensors do not require very complicated setup and/or high pump power to be launched in the sensing fiber, resulting in very simple and cost-effective interrogation systems.

Different methods have been proposed and implemented in order to interrogate the Bragg-frequency distribution along a FBG with the aim of implementing distributed temperature/strain sensors. Some of these salient techniques include optical low-coherence reflectometry (OLCR) [3], synthesis of optical coherence function (SOCF) [4] and optical frequency domain reflectometry (OFDR) [5], amongst others. In this context, OLCR technique has demonstrated very good performance in terms of spatial resolution. Anyway, this scheme presents a limited measurement range and a slow response time. On the other hand, SOCF allows a point-by-point characterization of the grating properties by simply tuning the modulation frequency of the optical source. Anyway, this technique requires a very complicated setup and hence expensive devices. Finally, OFDR enables temperature and strain measurements over long ranges with very good performance but comprising a sophisticated post processing scheme and an auxiliary interferometer used to avoid any non-linearity. Moreover, the system results polarization dependent and thus requires the presence of a polarization beam splitter and two separate photo-detectors (PDs) to

mitigate signal fading.

FBG sensors normally only supply information at discrete point, hence FBGs-based devices have been usually employed to perform highly sensitive discrete point sensing. Nevertheless, practical applications require fully distributed sensing in which the entire length of the fiber generates information [6], [7]. Regarding this, fiber distributed sensing based on very-weak reflectivity FBG has been demonstrated using optical time-domain reflectometry (OTDR) [8]. By scanning the laser frequency a distribution map of the reflectivity along the fiber has been obtained, demonstrating very good performance in terms of accuracy and signal response.

In this contribution, a technique to interrogate long FBGs and its potential applications to distributed fiber sensing is proposed and demonstrated. The fundamental concept for this approach is inspired on the operation principle of a discrete time microwave photonic (MWP) filter [9], [10], [11]. MWP is a discipline which collects together the field of microwave engineering with optoelectronics. Both microwave and optoelectronics obey to the same electromagnetic laws and then presents common features but also significant differences. In microwave domain, due to the large wavelength of microwave, construction of an interferometric structure does not require a precision as high as that needed by an optical interferometer. Moreover, microwave interferences can be more easily resolved than the optical interference in which the detecting devices are not fast enough to follow the very high optical frequency. For these reasons, the proposed technique brings several advantages derived from the fact that it relies on interference in the microwave rather than optical domain. Microwave interferometry is by far more stable and easier to control and, if suitably combined with photonics, provides a remarkable spatial accuracy. Furthermore, the system spectral performance can be easily reconfigured, since the sensor is based on a discrete time filter configuration. Thus, the methodology presented involves exploiting the best advantages brought by two symbiotic technologies: microwaves and photonics. Relying on microwave interferometry and working under incoherent operation, the configuration proposed is intrinsically robust against environmental changes, stable and with good repeatable performance [9], [10], [11]. Finally, this technique is potentially cost efficient as it is based on low bandwidth radio-frequency and off-the-shelf photonic components rather than on ultra-short pulses, optical interferometry or OFDR techniques.

The proposed technique is specifically suited when a spot event must be precisely identified and located, such as hot-spots or cracks in structures. The overall idea beyond this work has been borne out and demonstrated step by step starting from preliminary test that have led to the development of a very-long distributed sensor based on an array of weak FBGs. To get started, we have demonstrated the feasibility of the MWP filtering technique to interrogate a grating by using a 10 cm-long high reflectivity FBG as sensing device. Such a system proved to be able to detect several spot events with spatial accuracy less than 1 mm [12]. However, in this case since the FBG used as a quasi-distributed sensor has high reflectivity ($\approx 99\%$), the most important limitation arises from the fact that the system is not able to detect events having the same magnitude. Thus, to overcome this limitation a pair of low-reflectivity ($< 6\%$) FBGs has been employed as sensing device. With this configuration, several events have been detected with a spatial accuracy of less than 1 mm using a modulator and a photo-detector (PD) with a modest bandwidth of less than 500 MHz [13]. The latter has laid the foundation for the development and implementation of a long fiber optic sensor based on very weak FBGs (reflectivity ≈ 0.001). Hence, we have proposed and validated a distributed sensor consisting of a 5 m-long fiber, containing 500 equal 9 mm-long Bragg gratings. The detection of spot events along the sensor has been demonstrated with remarkable accuracy under 1 mm, using a PD and a modulator with a bandwidth of only 500 MHz [14]. All these sensors prove to be simple, robust, polarization insensitive and allow a lowering of the instrumentation complexity for distributed sensing applications.

2. Description of the method

The fundamental concept beyond the proposed methodology is inspired on the principle of operation of a MWP filter and is depicted in Fig. 1(a). The output of a continuous wave (CW) light source is electro-optically modulated with a microwave signal. At the output of the electro-optical modulator (EOM) the modulated optical signal is split into N arms. Each arm has a delay-line and an attenuator (or amplifier) in order to provide a delayed and weighted replica of the original signal. These time-delayed and weighted optical signals are combined together and photo-detected. In the detection process, the different taps can be mixed according to either a coherent or an incoherent basis. In case of incoherent mixing, the tap combination at the PD is insensitive to environmental effects, stable and with a remarkably good repeatable performance. For these reasons, the experimental setup that it is proposed to interrogate the long FBGs has been implemented under incoherent operation. Working under incoherent regime limits

the minimum delay between consecutive taps, which should be at least one order of magnitude greater than the source coherence time, as will be explained in the next section. The microwave signal is acquired and the electrical frequency response $H(\Omega)$ of such a structure is given by [10]:

$$H(\Omega) = \sum_{k=0}^N a_k e^{-j\Omega T_k} \quad (1)$$

where Ω is the angular frequency and a_k is the weight of the k -th replica that is delayed by T_k . When Eq. (1) identifies a transfer function with a periodic spectral characteristic, the frequency period is known as *free spectral range* (FSR) and it is inversely proportional to the spacing T between samples [10].

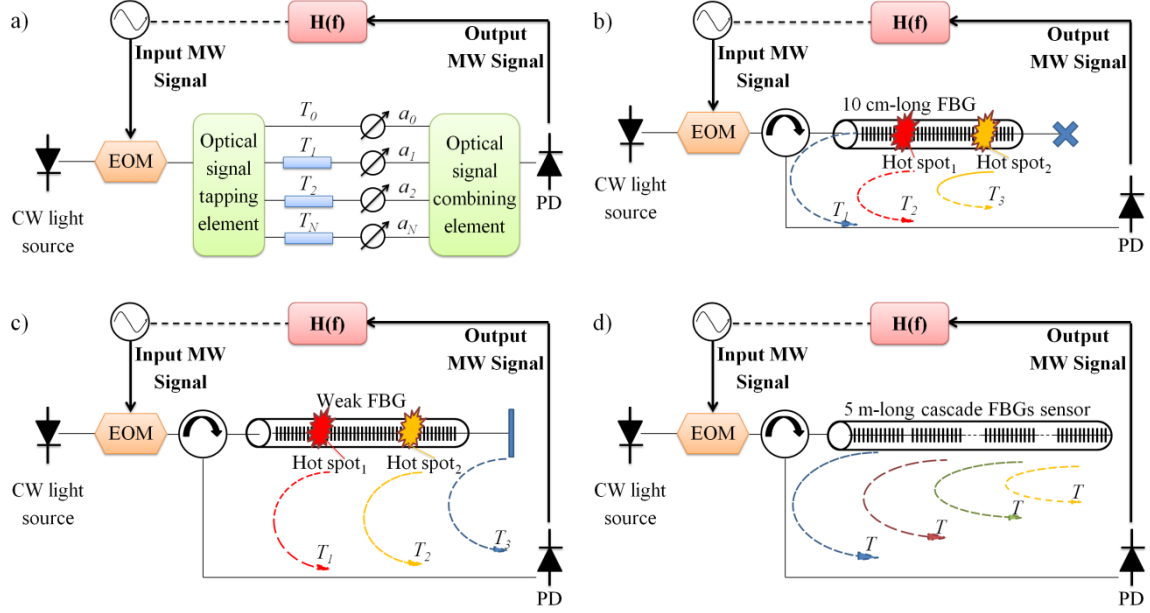

Fig. 1. a) Schematic diagram representing an N tap MWP filter configuration. b) Schematic layout implemented for interrogating the 10 cm-long high reflectivity FBG. c) Schematic layout for interrogating the fiber optic sensor based on a pair of weak FBGs. d) Schematic diagram for interrogating the 500 weak FBGs cascade sensor.

In the case of the high-reflectivity FBG, the sensor produces delayed replicas of the original signal at the input end of the FBG and at each of the hot-spots to be measured [12], [15]. Thus, the response of the FBG sensor is described also by Eq. (1), where the number of taps is equal to the number of hot spots plus one – the reference reflection normally placed at the entry point of the FBG – as illustrated in Fig. 1(b). While, when the weak FBGs are used as sensing device and the taps related to the original FBGs reflections are properly filtered out, the response of the weak FBG-pair is once again described by Eq. (1), but now the number of taps is equal to the number of hot spots plus one – the reference reflection produced at the end of the FBGs-based sensor and provided by the connector left open in the air – as shown in Fig. 1(c) [13], [15]. Finally, in the case of the 5 m-long FBG cascade device, delayed replica of the original signal at the place where each FBG is located have been produced, as depicted in Fig. 1(d) [14]. As the spacing between consecutive FBGs is constant, $T_k = T, \forall k$, Eq. (1) identifies a transfer function with a periodic spectral characteristic. The MWP filter so created presents $N - 1$ minima between two consecutive maxima (i.e. one FSR). Hence, the distance between minima in the electrical frequency response can be used to calculate the number of taps contributing to the filter frequency response. By evaluating the latter, the position and length of the hot spot along the FBG cascade distributed sensor can be retrieved with 1 mm accuracy, as will be explained afterwards.

3. Setup and experimental measurements

The setup used to interrogate the high-reflectivity 10 cm-long FBG is depicted in Fig. 2. The optical signal from a broadband source (BBS) is filtered by means of a tunable band-pass filter featuring a bandwidth of 0.45 nm centered at the Bragg wavelength of the grating. As previously mentioned the main

limitation of this technique arises from the fact that the conditions for incoherent regime operation have to be guaranteed. This implies that the minimum delay between two consecutive hot spots has to verify that $t_c \ll T$ where t_c , the optical source coherence time is given by [16]:

$$t_c = \frac{1}{\Delta f} \quad (2)$$

where Δf is the typical spectral bandwidth of the source. To reduce the value of t_c and to obtain a better range, a broadband source is proposed and used in all the configurations. In the case of a two tap MWP filter, the delay between the two consecutive tap T (which is inversely proportional to the FSR) is related to the distance L between them by:

$$T = \frac{1}{FSR} = \frac{2n_0L}{c} \quad (3)$$

being n_0 the effective refractive index of the fiber and c the speed of light in the vacuum. Hence to secure an incoherent regime of operation [12]:

$$L \gg \frac{\lambda^2}{2n_0\Delta\lambda} \quad (4)$$

where $\Delta\lambda$ is the source linewidth in wavelength units and λ its central emission wavelength. Using Eq. (2), a time coherence of 17.78 ps for the filtered optical source is obtained, which dictates smallest time spacing between hot-spots of ~ 100 ps. This implies that, for this configuration, the distance between hot-spots should be longer than 10 mm to maintain the conditions of the incoherent regime.

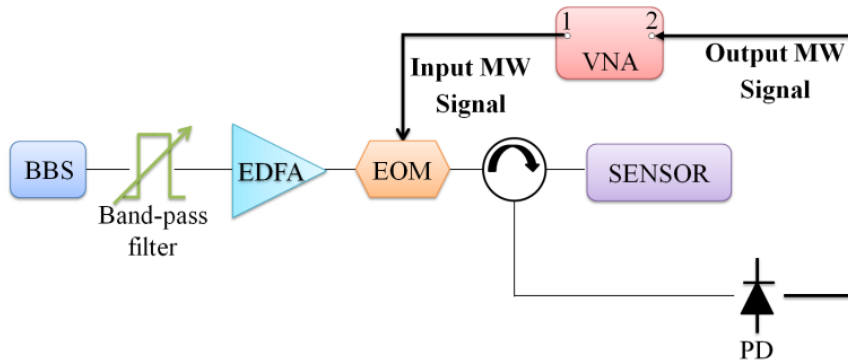

Fig. 2. Experimental setup used to interrogate the FBGs-based sensors using MWP filtering technique.

The output of the tunable filter is electro-optically modulated with a microwave signal generated by a vector network analyzer (VNA). The microwave signal consists of a radio-frequency tone swept from 10 MHz to 10 GHz. At the output of the EOM, the signal is sent amplified by means of an erbium doped fiber amplifier (EDFA) and then sent into the 10 cm-long FBG through an optical circulator. Finally, the signal reflected by the grating is photo-detected. In this way, the frequency response of the system can be analyzed by monitoring the scattering parameter S_{21} , which relates the radio-frequency detected signal to the input modulating microwave signal.

Due to the high reflectivity of the grating, most of the input signal is reflected at the initial section of the FBG [15]. However, a local change of temperature in a spot event placed at a certain point along the grating will produce a local Bragg frequency shift. When this occurs, besides the main reflected signal generated at the initial section of the grating, a second reflected signal is produced at the point where the hot spot is placed. In this way, the presence of a hot spot results in a two tap MWP filter and it is possible to determine the location of the hot spot by evaluating the FSR as it is described by Eq. (3).

Fig. 3(b) shows the experimental results obtained by moving the hot spot along the FBG as schematically illustrated in Fig. 3(a). As expected the recovered response is similar to a two tap MWP filter. The FSR has been evaluated with a frequency step of 0.01 MHz, which corresponds to an estimated spatial accuracy under 1 mm. The length spacing between the two taps is calculated according to the Eq. (3) and from this value the hot spot position is determined.

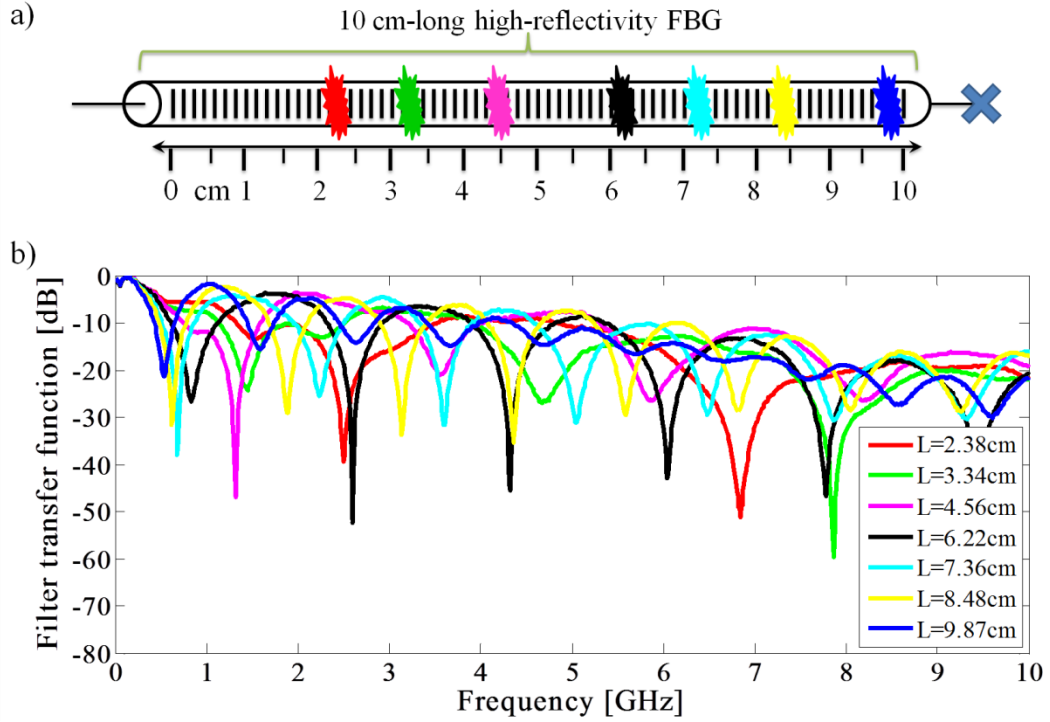

Fig. 3. a) Schematic illustrating the different position of the hot spot along the sensor. b) Frequency response of the two tap filters achieved by moving a hot spot on the 10 cm-long high reflectivity FBG.

The system is also able to detect the presence and position of two or more hot spots. Fig. 4(a) shows the response of the sensor when one and two hot spots are present (two and three tap filter, correspondingly). In the latter, since retrieving the delays directly from the transfer function is time consuming, the most efficient approach to calculate the distance between the input end of the FBG and the hot spots is simply to take the inverse Fourier transform (IFT) of the measured S_{21} parameter. Fig. 4(b) shows the IFT of the amplitude of the three tap filter transfer function illustrated in Fig. 4(a) where two hot spots are placed along the grating (blue curve) and the IFT of the amplitude of the two tap filter obtained when one of the hot spots is suppressed (red curve). The time differences between the main peaks and the two pairs of sub-pulses from Fig. 4(b) (blue curve) represent the time spacing between the beginning of the FBG and the locations of each of the hot spots. Hence, by using Eq. (3) the positions of both the hot spots have been calculated.

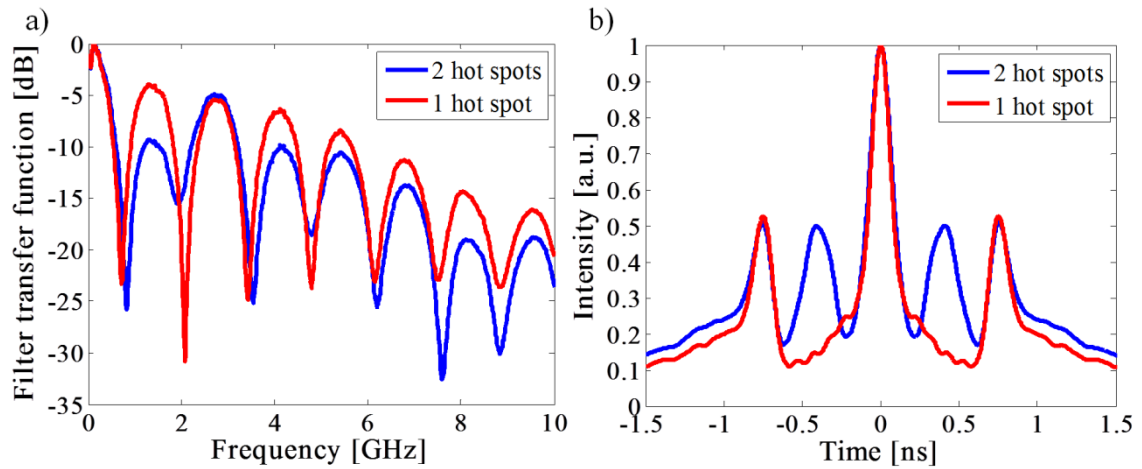

Fig. 4. a) Frequency response of the three tap and two tap filters obtained by placing two hot spots and one hot spot along the 10 cm-long grating, respectively. b) IFT of the amplitude of the MWP filters illustrated in Fig. 4(a).

Furthermore, in [12] we have demonstrated a second configuration to interrogate the high-reflectivity 10 cm-long FBG. In fact, to alleviate the bandwidth requirements of the modulator and the PD, a variant of the setup is proposed and validated. A reference arm is used in this case in order to obtain higher time spacing T between taps, which leads to a shorter FSR, when only one hot-spot is detected. In this case, the hot spot position can be evaluated by using a modulator and a PD with a modest bandwidth up to 1 GHz.

Anyway, in the former scheme, due to the high-reflectivity of the sensing FBG, the most important limitation arises from the fact that the system is not able to detect events having the same magnitude. To overcome this limitation, a weak FBGs-based sensing device able to detect one or more events having the same magnitude has been investigated. The interrogation system is similar to the configuration illustrated in Fig. 2, where now the 10 cm-long high-reflectivity FBG has been replaced to the weak FBGs-based device depicted in Fig. 5(a). Furthermore, this second test has been carried out by sweeping the radio-frequency signal in a limited frequency range from 10 MHz to 500 MHz, so reducing the system bandwidth requirements.

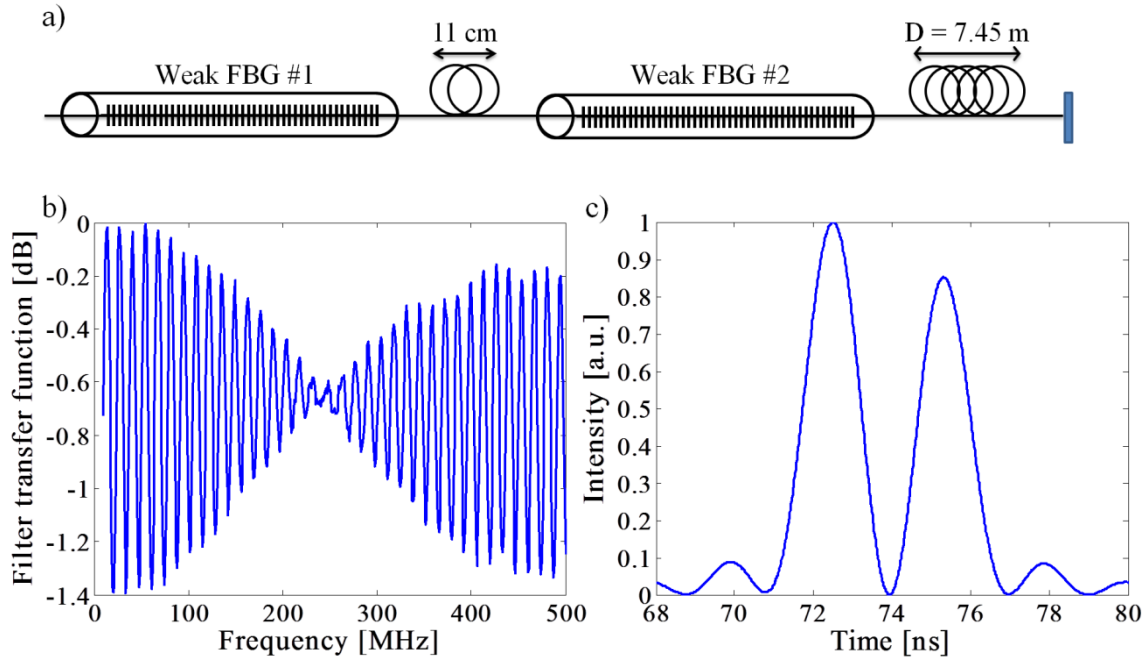

Fig. 5. a) Schematic of the fiber sensor based on a pair of weak FBGs. b) Frequency response of the three tap filter obtained by placing two hot spots along the weak FBGs-based sensor and by using the reflection at the end facet of the SMF as reference tap. c) IFT of the amplitude of the MWP filter depicted in Fig. 5(b).

The initial idea of this experiment was to fabricate a very long weak FBG, but due to the limitations of our FBGs fabrication system, FBGs longer than 10 cm cannot actually be fabricated. Hence, as a proof-of-concept, the quasi-distributed sensor proposed is made by a pair of weak ($R < 6\%$) 10 cm-long FBGs separated by 11 cm, while a piece of single-mode fiber (SMF) of length $D = 7.45$ m is appended after the second FBG. Finally, the other end of this fiber is left open in the air to provide a reflection signal that will be used as reference tap. The reason of this choice comes to the fact that in the case of a weak FBG, the input signal is continuously back-reflected while propagating through the entire length of the grating [15]. Hence we no longer have a reflection at the beginning of the grating that can be used as a reference point to establish the location of the hot spot along the sensor. Therefore we use the Fresnel reflection at the end facet of the fiber left open in the air as reference point to measure the location of the spot event.

When two hot spots are placed along each FBG and the band-pass filter is properly tuned in order to eliminate the original FBG reflections, a three tap filter is obtained, as shown in Fig. 5(b). In this case, the most efficient approach to calculate the positions of the two hot spots referred to the end of the SMF is simply to take the IFT of the measured S_{21} parameter, which is depicted in Fig. 5(c). By using Eq. (3) the above-mentioned distances have been calculated with a spatial accuracy of less than 1 mm, dictated by the VNA frequency step, using a modulator and a PD with a modest bandwidth of only 500 MHz.

The experiments and tests reported so far have demonstrated the capability of the approach based on a MWP filtering technique of interrogating quasi-distributed sensors based on grating structures. Against the backdrop of these positive results, we have proposed and validated a very long distributed sensor

based on 500 very weak FBGs equally spaced along the fiber. Once again, the system used to interrogate the fiber optics sensor is similar to the one depicted in Fig. 2, where the 5 m-long cascade sensor schematically illustrated in Fig. 6(a) is now employed as sensing element. The proposed device under test (DUT) is composed of an array of 500 identical very weak FBGs (reflectivity ≈ 0.001) written in cascade. The nominal length of each FBG is 9 mm and the separation between consecutive gratings is 10.21 mm. The FBG cascade fiber was kindly provided by FBGS International [17], which fabricates optical fibers by using Draw Tower Gratings (DTGs) Technology. This approach combines the drawing of the optical fiber with the simultaneous writing of the grating. During the fabrication process a glass pre-form is heated and then the puling and formation of the fiber is initiated. The FBG cascade sensor is continuously written and the pulse repetition rate is opportunely synchronized with the drawing speed in order to obtain an equal spacing between neighboring FBGs. This automated and controlled production process results in a very high quality, accurately positioned FBGs and ensures high repeatability and grating uniformity.

In the layout used to interrogate the 5 m-long sensor, the band-pass filter bandwidth has been chosen to be 1 nm. According to Eq. (2), the time coherence of the filtered optical source is 8 ps. The smallest time spacing which safely secures the incoherent regime operation would be at least an order of magnitude greater than this value. This implies that the distance between consecutive FBGs should be longer than 8.24 mm [16]; as the separation between the middle points of adjacent FBGs in the array is 10.21 mm, the incoherent regime operation is assured.

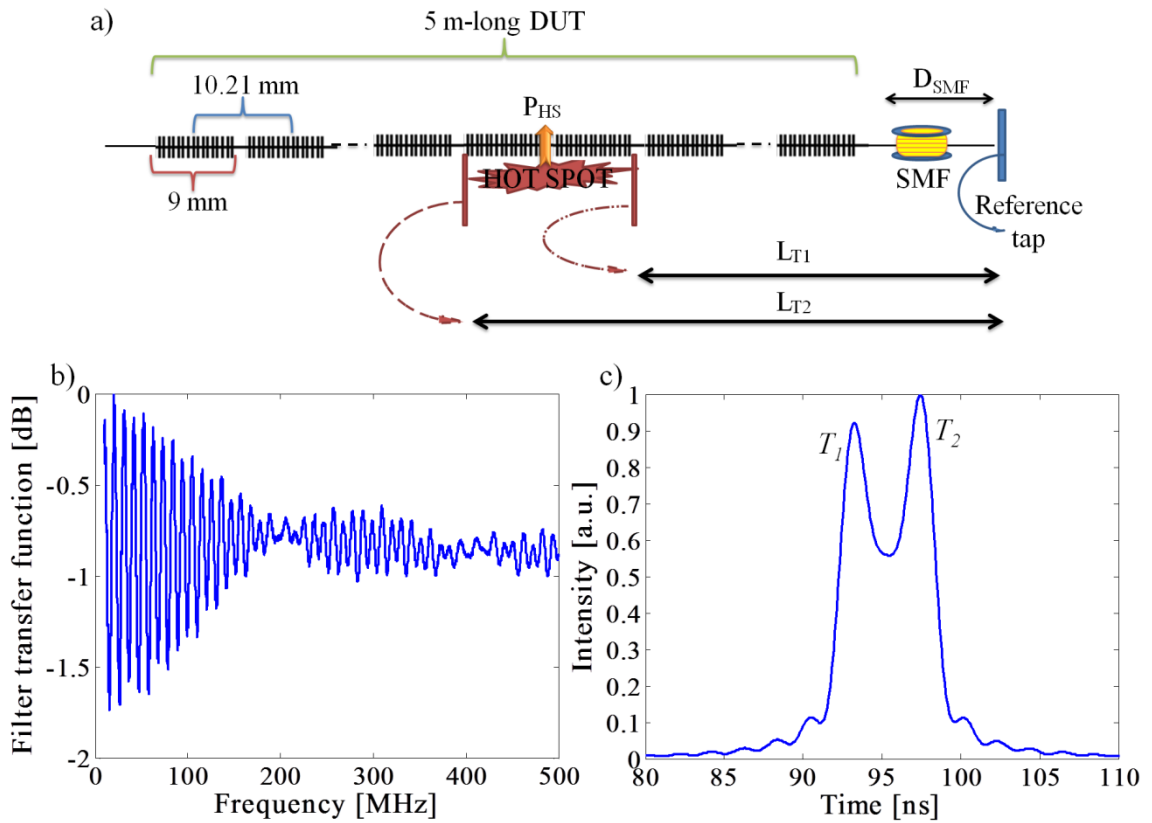

Fig. 6. a) Schematic of the 5 m-long distributed sensor based on 500 very weak FBGs written in cascade along the 5 m-long fiber. b) Frequency response of the MWP filter obtained by placing a hot spot along the DUT and by using the reflection at the end facet of the SMF as reference tap. c) IFT of the amplitude of the MWP filter illustrated in Fig. 6(b).

The FBGs very low reflectivity let us assume that the incoming signal is back-reflected with almost the same weight from each of the 500 FBGs. In a similar way as we have illustrated for the previous systems, the value of the first main resonance (i.e. the FSR span) is related to the distance between consecutive FBGs. Hence, taking advantage of this concept, the length of a spot event located along the sensing fiber can be evaluated. In fact, the MWP filter presents $N - 1$ minima between two maxima. The distance between two minima (hereinafter FSR') can be used to calculate the number of taps contributing to the filter response. As the separation between gratings in the array is known, by evaluating the FSR' of the MWP filter, the length L_{HS} of the hot spot can be calculated according to:

$$L_{HS} = \frac{c}{2n_0 FSR'} \quad (5)$$

To corroborate this assumption, an experiment has been carried out using a frequency span from 10 MHz to 500 MHz. When a hot spot is placed along the 5 m-long sensing fiber, the heated surface suffers a period shift which leads to a Bragg wavelength shift affecting the FBGs underlying the hot zone. If the optical filter is properly tuned in order to select the zone of the source spectrum reflected by the heated gratings, the distance between minima in $H(\Omega)$ gives length of the hot spot. In other words, by evaluating the FSR' of the MWP filter and by using Eq. (5), the length of the hot zone can be calculated, with a spatial accuracy under 1 mm, dictated by the spatial resolution of the VNA.

Furthermore, in order to estimate the position of the spot event along the DUT, a piece of a SMF of length $D_{SMF} = 7$ m is appended at the end of the DUT, as illustrated in Fig. 6(a). The other end of the SMF is left open in the air to provide a reflection signal that will be used as reference tap. The transfer function of the MWP filter so created is shown in Fig. 6(b). The distance between the two ends of the hot spot and the end facet of the SMF L_{T1} and L_{T2} are related to the respective transit time between the end of the hot spot and the end facet of the SMF T_1 and T_2 by:

$$L_{Ti} = \frac{cT_i}{2n_0}, i = 1,2 \quad (6)$$

Now, by taking the IFT of the measured S_{21} parameter, which is plotted in Fig. 6(c), the length of the hot spot $L_{HS} = L_{T2} - L_{T1}$ has been calculated to be 50.72 cm, while the position of its middle point P_{HS} can be evaluated by $P_{HS} = (L_{T2} + L_{T1})/2 - D_{SMF}$, resulting in $P_{HS} = 2.8440$ m.

It is worth mentioning that the minimum detectable hot spot is directly related to the VNA frequency span Δf_{VNA} ; the ultimate limit in the hot spot length and locations results to be:

$$L_{HS \min} = \frac{c}{2n_0 \Delta f_{VNA}} \quad (7)$$

Even so, it is possible to release this limitation if the number of replicas of the MWP filter is increased, either by extending the frequency range or by mathematically improving the algorithm used for the IFT.

Finally, in all configurations presented, the temperature of the hot spot can be evaluated due to the progressive scan of the central wavelength of the tunable band-pass filter, without using any more devices or additional wavelength scanned systems. For instance, in the last scheme proposed, the temperature of the hot spot is estimated to be around 70 °C, with an accuracy of 1 °C, based on the fiber temperature coefficient. Besides, the sensor temperature resolution will be limited by the transition slope of the optical band-pass filter and will be certainly improved by using a tunable optical filter with high abrupt transition slope.

4. Conclusions

A technique for estimating the position, length and number of spot events along different FBGs-based sensors has been described and demonstrated via experiments, based on the principle of operation of a MWP filter. By evaluating the FSR of the resulting MWP filter (or equivalently by calculating the IFT of the measured S_{21} parameter) the location and length of several spot events along the distributed FBG sensors can be detected with a remarkable accuracy dictated by the spatial resolution of the VNA.

The overall idea beyond this work has been borne out and demonstrated step by step starting from preliminary experiments. To get started, we have demonstrated the feasibility of the MWP filtering technique to interrogate a grating by using a 10 cm-long high reflectivity FBG. Although such a system proved to be able to detect several spot events, however, since the FBG has high reflectivity ($\approx 99\%$), the most important limitation arises from the fact that the system is not able to detect events having the same magnitude. To overcome this limitation a pair of low-reflectivity ($< 6\%$) FBGs has been employed as sensing device. With this configuration, several events have been detected with a spatial accuracy of less than 1 mm using a modulator and a PD with a modest bandwidth of less than 500 MHz. The latter has laid the foundation for the development and implementation of a 5 m-long fiber optic sensor based on 500 identical very weak FBGs (reflectivity ≈ 0.001). The detection of spot events along the sensor has been demonstrated with remarkable accuracy of less than 1 mm, using a PD and a modulator with a bandwidth of only 500 MHz. Since the spatial accuracy basically depends on the system frequency step, the MWP-

based methodology will be certainly able to reach the same performance in terms of accuracy even if the length of the sensing device is enhanced to obtain a higher measurement range. Also, the spatial accuracy can be further improved using a higher range instrument. The more abrupt is the transition slope of the optical filter, the better will be the system temperature resolution.

Furthermore, in all configurations presented, the temperature of the hot spot can be evaluated due to the progressive scan of the central wavelength of the tunable band-pass filter, without using any more devices or additional wavelength scanned systems. In the case of the 500 FBGs cascade sensor, we have achieved a temperature accuracy of 1°C, depending on the fiber temperature coefficient.

Moreover, relying on microwave interferometry and working under incoherent operation, the configurations proposed result intrinsically robust against environmental changes, stable and with remarkable good repeatable performance. For these reasons the measurements of the MWP filter response have been achieved with no need of averaging mode. The technique is potentially quasi-cost effectively solution as it is based on low bandwidth radiofrequency and off-the-shelf photonic components rather than on ultra-short pulses, optical interferometry or OFDR techniques.

Finally, it is worth mentioning that all the MWP filtering interrogation systems described in this review can also be used to implement crack/strain sensors. Besides, the use of a BBS relieves the complexity and the cost for stabilization control on light source, and since microwave frequencies changes were measured, the influence of the intensity noise of the incoherent source does not lead to resolution impoverishment. Furthermore, although the use of a VNA may enhance the system complexity and expense, the instrumentation required could be simplified by replacing the VNA with an oscillator and a device able to analyze the magnitude response of the MWP filter generated. The simple proposed scheme proves to be cost effective and intrinsically robust against environmental changes and easy to reconfigure.

Acknowledgment

This work was support by the Acción Financiada por el Ministerio de Educación, Cultura y Deporte within the framework of the Programa de Campus de Excelencia Internacional VLC/Campus, by the Spanish MINECO through projects TEC2014-60378-C2-1-R, by the Grant of the program SANTIAGO GRISOLÍA (Grant number GRISOLÍA/2013/034), and by the Research Excellency Award Program GVA PROMETEO2013/012.

References

- [1] B. Culshaw, "Optical fiber sensor technologies: opportunities and perhaps pitfalls," *J. Lightw. Technol.*, vol. 22, no. 1, pp. 39-50, Jan. 2004.
- [2] A. D. Kersey, M. A. Davis, H. J. Patrick, M. LeBlanc, K. P. Koo, C. G. Askins, M. A. Putnam, and E. J. Friebele, "Fiber grating sensors," *J. Lightw. Technol.*, vol. 15, no. 8, pp. 1442-1463, Aug. 1997.
- [3] M. Volanthen, H. Geiger, and J. P. Dakin., "Distributed grating sensors using low-coherence reflectometry," *J. Lightw. Technol.*, vol. 15, no. 11, pp. 2076-2082, Nov. 1997.
- [4] K. Hotate and K. Kajiwar, "Proposal and experimental verification of Bragg wavelength distribution measurement within a long-length FBG by synthesis of optical coherence function," *Opt. Express*, vol. 16, no. 11, pp. 7881-7887, May 2008.
- [5] H. Murayama, H. Igawa, K. Kageyama, K. Ohta, I. Ohsawa, K. Uzawa, M. Kanai, T. Kasai, and I. Yamaguchi, "Distributed strain measurement with high spatial resolution using fiber Bragg gratings and optical frequency domain reflectometry," in *Optical Fiber Sensors*, OSA Technical Digest (CD) (Optical Society of America, 2006), paper ThE40.
- [6] A. Rogers, "Distributed optical-fibre sensing," *Meas. Sci. Technol.*, vol. 10, no. 8, pp. R75-R99, Aug. 1999.
- [7] X. Bao and L. Chen "Recent progress in distributed fiber optic sensors", *Sensors*, vol. 12, no. 7, pp.8601-8639, Jun. 2012.
- [8] L. Thévenaz, S. Chin, J. Sancho, and S. Sales, "Novel technique for distributed fibre sensing based on faint long gratings (FLOGs)," *Proc. SPIE*, vol. 9157, pp. 91576W1-4, Oct. 2014; doi:10.1117/12.2059668.
- [9] J. Capmany, B. Ortega, D. Pastor, and S. Sales, "Discrete-time optical processing of microwave signals," *J. Lightw. Technol.*, vol. 23, no. 2, pp. 702-723, Feb. 2005.
- [10] J. Capmany, J. Mora, I. Gasulla, J. Sancho, J. Lloret, and S. Sales, "Microwave photonic signal processing," *J. Lightw. Technol.*, vol. 31, no. 4, pp. 571-586, Feb. 2013.
- [11] J. Yao, "Microwave photonics," *J. Lightw. Technol.*, vol. 27, no. 3, pp. 314-335, Feb. 2009.
- [12] A. L. Ricchiuti, D. Barrera, S. Sales, L. Thévenaz, and J. Capmany, "Long fiber Bragg grating sensor interrogation using discrete-time microwave photonic filtering techniques," *Opt. Express*, vol. 21, no. 23, pp. 28175-28181, Nov. 2013.
- [13] A. L. Ricchiuti, D. Barrera, S. Sales, L. Thévenaz, and J. Capmany, "Long weak FBG sensor interrogation using microwave photonics filtering technique," *IEEE Phot. Technol. Lett.*, vol. 26, no. 20, pp. 2039-2042, Oct. 2014.
- [14] A. L. Ricchiuti, J. Hervás, D. Barrera, S. Sales, and J. Capmany, "Microwave photonics filtering technique for interrogating a very-weak fiber Bragg grating cascade sensor," *IEEE Photon. J.*, vol. 6, no. 6, pp. 5501410-1-5501410-10, Dec. 2014.

- [15] L. R. Chen, S. D. Benjamin, P. W. E. Smith, and J. E. Sipe, "Ultrashort pulse reflection from fiber gratings: a numerical investigation," *J. Lightw. Technol.*, vol. 15, no. 8, pp. 1503-1512, Aug. 1997.
- [16] B.E.A. Saleh and M.C. Teich, *Fundamentals of Photonics*, 2nd ed. (Wiley, New York, 2007).
- [17] *FBGS-Draw Tower Gratings*. [Online]. Available: <http://www.fbgs.com/home/>

Biographies

Amelia Lavinia Ricchiuti was born in Taranto, Italy, in 1985. During 2009-2010 she attended the School of Telecommunications Engineering of the Universidad Politécnica de Valencia (UPV) as Erasmus student. She received the Bachelor's degree and the M.S. in Electronic, Information and Telecommunications Engineering both with highest honors from the Politecnico di Bari, Italy, in 2008 and 2011, respectively. She completed the Official Master's Degree in Communications Technologies, Systems and Networks of the UPV in 2013. She joined the Optical and Quantum Communication Group (OQCG) of the UPV, as Researcher and Ph.D. Student in 2012. Her main research interests include the study, design and fabrication of customized FBGs, optical sensors and applications, microwave photonics techniques, systems and applications.

Javier Hervás was born in Valencia, Spain, in 1988. He received the Bachelor's degree in telecommunications engineering and the M.S. degree, both from the Universidad Politécnica de Valencia, Valencia, in 2013 and 2014, respectively. He is currently working toward the Ph.D. degree in communications engineering at the Optical and Quantum Communication Group (OQCG), supported by the Spanish Ministry of Science and Innovation. In 2013, he joined the OQCG as a Researcher and was first involved in the FBGs sensors field. His research interests include the design and fabrication of FBGs, multicore fibers applications, optical sensors and microwave photonics applications.

Salvador Sales (S'93–M'98–SM'04) received the M.Sc. and the Ph.D. degrees from the Universitat Politècnica de València, Valencia, Spain. He is Professor at the ITEAM Research Institute, Universitat Politècnica de València, Valencia, since 2007. He was recognized with the Annual Award of the Spanish Telecommunication Engineering Association for the best Ph.D. on optical communications. He is coauthor of more than 125 journal papers and 300 international conferences. He has been collaborating and leading some national and European research projects since 1997. His main research interests include optoelectronic signal processing for optronic and microwave systems, optical delay lines, fiber Bragg gratings, WDM and SCM lightwave systems and semiconductor optical amplifiers.