

Document downloaded from:

<http://hdl.handle.net/10251/99050>

This paper must be cited as:

Llopis Doménech, R.; Cabello, R.; Sanchez, D.; Torrella Alcaraz, E. (2015). Energy improvements of CO₂ transcritical refrigeration cycles using dedicated mechanical subcooling. *International Journal of Refrigeration*. 55:129-141.
doi:10.1016/j.ijrefrig.2015.03.016



The final publication is available at

<https://doi.org/10.1016/j.ijrefrig.2015.03.016>

Copyright Elsevier

Additional Information

Energy improvements of CO₂ transcritical refrigeration cycles using dedicated mechanical subcooling

Rodrigo Llopis^{1,}, Ramón Cabello¹, Daniel Sánchez¹, Enrique Torrella²*

*¹Jaume I University, Dep. of Mechanical Engineering and Construction, Campus de Riu Sec s/n
E-12071, Castellón, Spain*

*²Polytechnic University of Valencia, Department of Applied Thermodynamics, Camino de Vera, 14,
E-46022, Valencia, Spain*

*Corresponding author: R. Llopis (rllopis@uji.es), Phone: +34 964 72 8136; Fax: +34 964 728106.

ABSTRACT

In this work the possibilities of enhancing the energy performance of CO₂ transcritical refrigeration systems using a dedicated mechanical subcooling cycle are analysed theoretically. Using simplified models of the cycles, the modification of the optimum operating conditions of the CO₂ transcritical cycle by the use of the mechanical subcooling are analysed and discussed. Next, for the optimum conditions, the possibilities of improving the energy performance of the transcritical cycle with the mechanical subcooling are evaluated for three evaporating levels (5, -5 and -30 °C) for environment temperatures from 20 to 35 °C using propane as refrigerant for the subcooling cycle. It has been observed that the cycle combination will allow increasing the COP up to a maximum of 20% and the cooling capacity up to a maximum of 28.8%, being both increments higher at high evaporating levels. Furthermore, the results indicate that this cycle is more convenient for environment temperatures above 25 °C. Finally, the results using different refrigerants for the mechanical subcooling cycle are presented, where no important differences are observed.

KEYWORDS

CO₂, transcritical, mechanical subcooling cycle, energy efficiency

NOMENCLATURE

COP	coefficient of performance
h	specific enthalpy, $\text{kJ}\cdot\text{kg}^{-1}$
\dot{m}	refrigerant mass flow rate, $\text{kg}\cdot\text{s}^{-1}$
p	pressure, bar
P_c	compressor power consumption, kW
q_o	specific cooling capacity, $\text{kJ}\cdot\text{kg}^{-1}$
SUB	subcooling degree of CO_2 at the exit of the gas-cooler
t	compression ratio
T	temperature, $^{\circ}\text{C}$
w_c	specific compression work, $\text{kJ}\cdot\text{kg}^{-1}$

GREEK SYMBOLS

η_i	isentropic efficiency of the compressor
η_v	volumetric efficiency of the compressor
Δ	increment

SUBSCRIPTS

$1.stage$	refers to single-stage compressors
dis	compressor discharge
env	environment
gc	gas-cooler
H	second compression stage
i	inlet
K	condenser
L	first compression stage
ms	of the dedicated mechanical subcooling cycle
o	outlet
O	evaporator
r	of the CO_2 transcritical cycle
sub	subcooling
suc	compressor suction
ves	vessel

1. Introduction

At present, the Refrigeration Sector is undergoing one of its most important renewal processes, the transition from traditional refrigerants, with high environmental impact, to more sustainable refrigerants, most of them from the natural family. The progenitor of this process was the scientific community with the goal to develop new refrigeration systems with new refrigerants to reduce their environmental impact, but the force that has favoured the implantation of the new systems have been the regulations derived from the Kyoto Protocol. For example in Europe, the new F-Gas Regulation (European Commission, 2014) was approved in March 2014 and will come into force in 2015. Its restrictions to the use of fluorinated refrigerants mainly affect the centralized commercial refrigeration sector, where only refrigerants with a GWP lower than 150 could be used from 2020 on, except for the primary refrigerant of cascade systems, where a GWP limit of 2500 has been established. Its consequence for centralized refrigeration systems at low temperature will be the transition from the R404A or R507A to CO₂

CO₂ in centralized commercial refrigeration systems is put into practice with cascades or pure transcritical systems. According to the Shecco Guide (2014), there are 2885 supermarkets operating with pure transcritical systems and 1638 with HFC/CO₂ cascades in Europe now. However, when referring to warm countries, such Spain or Italy, only 21 supermarkets operate with transcritical systems and 231 operate with cascades. The preferred solution for warm countries is the cascade, since when the environment temperature is high the performance of pure transcritical systems is far away from that offered by the cascades (Llopis et al., 2015).

Several researchers have studied modifications of CO₂ transcritical systems to improve their efficiency to try to reach the performance of other solutions. Aprea & Maiorino (2008), Torrella et al. (2011) and Sánchez et al. (2014) studied the improvements due to the use of internal heat exchangers (IHX) in single-stage plants and Cavallini et al. (2005; 2007) in two-stage systems. All the experimental analysis demonstrated that the IHX can improve the COP of the cycle up to a 10% approximately, because it increments the specific cooling capacity and reduces the optimum high pressure. Others analysed experimentally the effect of vapour extraction from the vessel to inject it in different points of the refrigeration cycle. The improvements of COP reached up to 7% in single-stage cycles (Cabello et al., 2012) and 16.5% in double-stage plants (Cho et al., 2009). Other improvements are the use of expanders (Li et al., 2004; Yang et al., 2007) and ejectors (He et al., 2014; Lee et al., 2014) to reduce irreversibilities during the expansion process, which also offered COP increments. In parallel, control strategies to regulate the heat rejection pressure were developed (Aprea and Maiorino, 2009; Ge and Tassou, 2009; Peñarrocha et al., 2014). And now, the improvements of performance of CO₂ transcritical plants are also considered by combining them with other thermal systems via recovering heat in the gas-cooler. Aprea et

al. (2015) analysed the combination of the refrigeration plant with a desiccant wheel for air conditioning purposes and Arora et al. (2011), from a theoretical approach, studied their combination with H₂O-BrLi absorption plants.

Another recent approach to improve the performance of CO₂ transcritical refrigeration plants is via subcooling the refrigerant at the exit of the gas-cooler. This subcooling allows increasing the specific cooling capacity of the plant and also for transcritical systems reducing the optimum heat rejection pressure. This approach was studied theoretically by Sarkar (2013) using a thermoelectric device driven by the heat rejected in the gas-cooler. His theoretical results showed that improvements of COP up to 25.6% can be reached. A similar strategy, based on subcooling the refrigerant at the exit of the gas-cooler, can be reached by using the dedicated mechanical subcooling cycle (MS), reintroduced by Zubair in 1994. The combination of this cycle with main refrigeration system is shown in Figure 1. The MS cycle is used to subcool the refrigerant of a main cycle at the exit of the condenser through their thermal coupling in the subcooler. Both cycles perform heat rejection over the same hot heat sink. The COP improvement due to the use of the MS cycle can be quantified by comparing the overall COP of the cycles with and without the MS cycle using heat balances in the cycles and in the subcooler. Equation (1) represents the COP of the main cycle without using the MS cycle, Equation (2) the COP of the whole cycle when both are in use, and Equation (3) the relation of refrigerant mass flow rates of the cycles obtained with the energy balance in the subcooler. q_o corresponds to the specific cooling capacity of the main cycle and $q_{o,ms}$ of the MS cycle, Δh_{sub} the enthalpy difference of the main refrigerant in the subcooler, and w_c and w_{ms} the specific compression works of the main and the MS cycles respectively.

$$COP = \frac{q_o}{w_c} \quad (1)$$

$$COP^* = \frac{q_o + \Delta h_{sub}}{w_c + w_{c,ms}} \quad (2)$$

$$\dot{m}_{ms} = \dot{m}_r \cdot \frac{\Delta h_{sub}}{q_{o,ms}} \quad (3)$$

The effect of the MS cycle on the cycle combination is positive if $COP^* > COP$. After manipulation of Equations (1) to (3), it can be demonstrated that the use of the MS cycle is positive if the COP of the MS cycle is higher than the COP of the main cycle, Equation (4). In general, the condition established by Equation (4) would be always satisfied if both cycles perform the heat rejection over the same hot heat sink and the evaporating temperature of the MS cycle is higher than the evaporating temperature of the main cycle.

$$COP_{ms} > COP$$

(4)

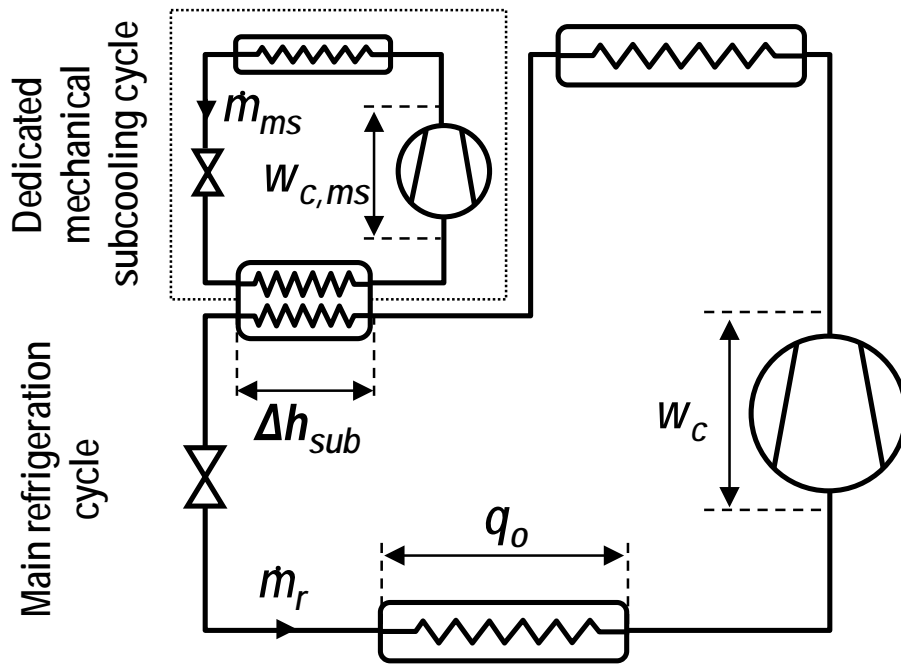

Figure 1. Schematic representation of the dedicated mechanical subcooling cycle

In recent studies of Qureshi & Zubair (2012a, b), it was studied theoretically the effect of the MS cycle on main cycles working with R134a and R717. They observed that MS cycle offered more benefits for cycles with R134a than with R717, being in both cases the effect positive. They considered for the MS cycle the refrigerants R407C, R134a and R410A. Also, they analysed the impact of fouling in the evaporator on the performance of the combination. These studies were completed with an initial experimental analysis (Qureshi et al., 2013) in a R22 single-stage cycle using R12 as refrigerant for the MS cycle. They measured that the MS cycle was positive, since it allowed increasing the cooling capacity and enhancing the second-law efficiency by an average of 21%. Also, they observed that the increase in efficiency is inversely proportional to ambient temperature variations. However, no more experimental and theoretical studies about the use of the MS cycle have been found by the authors.

The use of the MS cycle in CO₂ transcritical plants will have two implications: First, in the same way that for main cycles working with HFC, the subcooling will increase the capacity and increment the overall COP if condition of Equation (4) is satisfied. And second, as observed by Sarkar (2013), introducing a subcooling after the gas-cooler allows reducing the optimum heat rejection temperature and the compression ratio of the main cycle, generating thus additional benefits. Accordingly, the use of the MS

cycle in CO₂ transcritical plants could bring more benefits than in HFC systems, however, no information has been found in the literature. Therefore, the objective of this paper is to quantify theoretically its contributions or energy enhancements in CO₂ transcritical refrigeration systems. The analysis is made considering simplified but realistic models of two CO₂ transcritical refrigeration systems, single and double-stage, which are subcooled by a R290 single-stage refrigeration cycle for different evaporating, environment temperatures and different subcooling degrees. Also different refrigerants for the MS cycle have been studied. Obviously, the results are a close approximation of what would happen, but a second stage of experimentation is needed to corroborate these results.

2. Model description

To analyse the possibilities of enhancing the performance of CO₂ transcritical refrigeration plants using the dedicated mechanical subcooling cycle, we consider the cycle of Figure 2. It is a CO₂ transcritical cycle with a double-stage expansion system (Cabello et al., 2008) with an additional subcooler at the exit of the gas-cooler, where the subcooling is provided by a single-stage compression system, the MS cycle. The transcritical cycle incorporates a device to regulate the heat rejection pressure and another to control the evaporating process. For the evaluation two compression systems are considered in the main cycle, single-stage for medium and high evaporating temperatures and two-stage with intercooling for low evaporating temperatures. Both cycles perform the heat rejection (in condenser of the MS cycle, in the gas-cooler and in the intercooler of the transcritical cycle) to the same hot sink, the environment temperature.

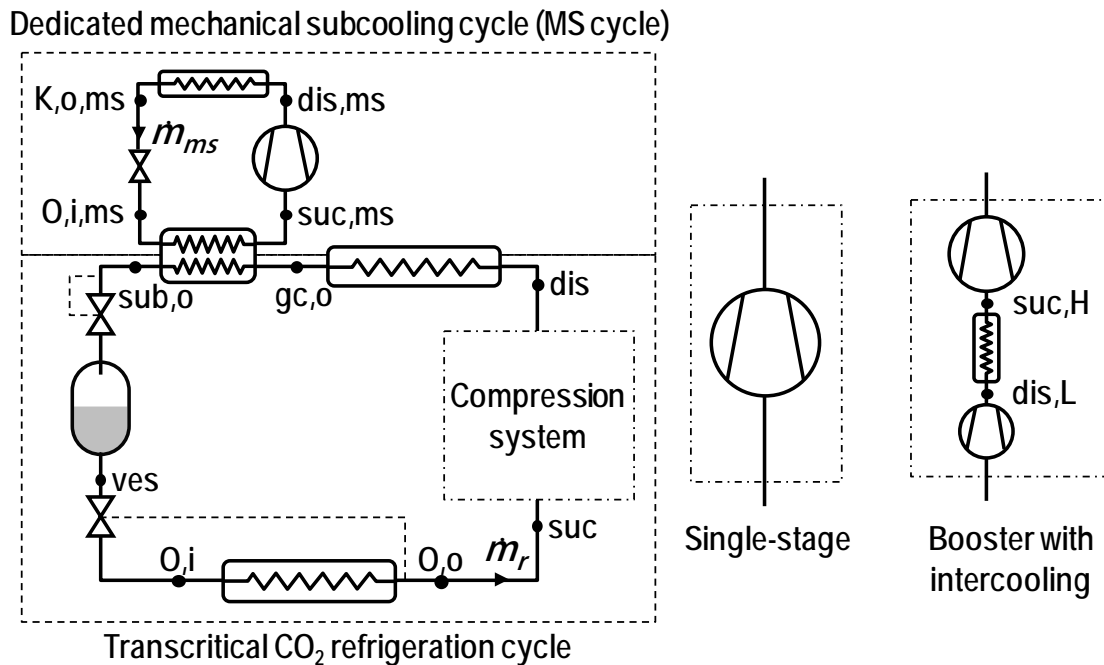

Figure 2. CO₂ transcritical refrigeration plant with dedicated mechanical subcooling

The evaluation of the system, made using the thermodynamic properties from Refprop 9 database (Lemmon et al., 2010). We detail the considerations and assumptions to model each cycle in the next subsections.

2.1. Transcritical CO₂ refrigeration cycle

To evaluate the CO₂ transcritical cycle, we neglect pressure losses and heat transfer to the environment, we fix the evaporation temperature and a constant degree of superheat in the evaporator of 10°C. All the

calculations are made for the optimum heat rejection pressure, which is calculated through an iteration process.

To obtain gas-cooler outlet temperature (gc,o) an approach temperature to the environment of 5 °C is chosen, Equation (5), due to the high heat transfer rates of CO₂ in transcritical conditions (Kim et al., 2004). Next, the outlet temperature of the subcooler (sub,o) is obtained considering a determinate subcooling degree in this heat exchanger (SUB), Equation (6), which is provided by the mechanical subcooling cycle and will be varied in the analysis. The enthalpy difference of CO₂ in the subcooler (Δh_{sub}) is evaluated with Equation (7).

$$T_{gc,o} = T_{env} + 5 \text{ }^{\circ}\text{C} \quad (5)$$

$$T_{sub,o} = T_{gc,o} - SUB \quad (6)$$

$$\Delta h_{sub} = h_{gc,o} - h_{sub,o} \quad (7)$$

The specific cooling capacity, considering all the lamination process isenthalpic, is evaluated with Equation (8).

$$q_o = h_{o,o} - h_{sub,o} = h_{o,o} - h_{gc,o} + \Delta h_{sub} \quad (8)$$

To consider a simple but realistic approach the compressors are modelled using the same curve of isentropic efficiency, Equation (9), close to one obtained for a transcritical CO₂ compressor (Sánchez et al., 2010). Furthermore, to evaluate the modifications of the cooling capacity provided by the transcritical cycle the volumetric efficiency is considered to be equal to the isentropic efficiency.

$$\eta_i = \eta_v = 0.95 - 0.1 \cdot t \quad (9)$$

For the single-stage compressor, used for high and medium evaporating temperatures, the specific compression work is evaluated with Equation (10), where the discharge pressure is equal to the heat rejection pressure and the suction pressure equal to the evaporating pressure. $h_{dis,s}$ is the discharge isentropic enthalpy and $\eta_{i,1.stage}$ the isentropic efficiency between discharge and suction pressures.

$$w_c = \frac{h_{dis,s} - h_{suc}}{\eta_{i,1.stage}} \quad (10)$$

For the double stage compression system, modelled as a booster configuration with intercooler, we consider an inter-stage pressure equal to the geometric mean of the pressure in the gas-cooler and in the evaporator, Equation (11).

$$p_{dis,L} = p_{suc,H} = \sqrt{p_0 \cdot p_{gc}} \quad (11)$$

The specific compression work in the first compression stage is calculated with Equation (12), where $h_{dis,L,S}$ is the discharge isentropic enthalpy of the first stage to the inter-stage pressure defined by (11) and $\eta_{i,L}$ the isentropic efficiency of the first stage between the inter-stage and suction pressures.

$$w_{c,L} = \frac{h_{dis,L,S} - h_{suc}}{\eta_{i,L}} \quad (12)$$

Next, to obtain the suction temperature of the second compression stage, we also consider an approach temperature with environment of 5 °C, as expressed by Equation (13).

$$T_{suc,H} = T_{env} + 5 \text{ } ^\circ\text{C} \quad (13)$$

From this temperature, the specific compression work of the second stage is calculate with Equation (14), where $h_{dis,H,S}$ is the discharge isentropic enthalpy of the second stage to the heat rejection pressure and $\eta_{i,H}$ the isentropic efficiency of the second stage between the heat rejection and the inter-stage pressure. Finally, the specific compression work of the double-stage configuration is computed with Equation (15).

$$w_{c,H} = \frac{h_{dis,H,S} - h_{suc,H}}{\eta_{i,H}} \quad (14)$$

$$w_c = w_{c,L} + w_{c,H} \quad (15)$$

2.2. Dedicated mechanical subcooling cycle (MS cycle)

For this cycle we consider only subcritical fluids. Pressure losses and heat transfer to the environment is neglected. Its condensing pressure is evaluated considering a temperature difference with the environment of 10 °C. The exit of the condenser is in saturation. To fix the evaporating level two criteria can be followed: First, it is possible to consider a fixed temperature difference between the evaporating temperature and the average temperature of CO₂ in the subcooler. This criteria would provide better results, however, in most of the cases the evaporating temperature would be out of the operating range of the compressors (in general 10°C). Second, the evaporating temperature of the MS cycle can be fixed to the maximum operating pressure of the high temperature compressors, in this case 10°C. We consider the second criteria, since it is the best approximation to reality, however, this criteria would provide lower

energy results than the first. For the calculations we used a constant degree of superheat in the evaporator of 10°C.

Accordingly, and considering the expansion process as isenthalpic, the specific cooling capacity of the MS cycle is expressed by Equation (16).

$$q_{o,ms} = h_{O,o,ms} - h_{K,o,ms} \quad (16)$$

To evaluate the specific compression work we use the same curve of isentropic efficiency than for the CO₂ compressors, Equation (9), therefore, it can be evaluated with relation (17), where $h_{dis,s,ms}$ is the isentropic discharge enthalpy to the condensing pressure and $\eta_{i,ms}$ is the isentropic efficiency of the compressor between condensing and evaporating pressures.

$$w_{c,ms} = \frac{h_{dis,s,ms} - h_{suc,ms}}{\eta_{i,ms}} \quad (17)$$

2.3. Complete system

The performance of the cycle combination can be expressed using the heat balance in the subcooler, Equation (3), which provides the relation between the refrigerant mass flow rates in the cycles. Using it, the ratio between the power consumption of the cycles is expressed by Equation (18). And the overall COP by Equation (19).

$$\frac{P_{C,ms}}{P_C} = \frac{\dot{m}_{ms} \cdot w_{c,ms}}{\dot{m}_r \cdot w_C} = \frac{\Delta h_{sub} \cdot w_{c,ms}}{q_{o,ms} \cdot w_C} \quad (18)$$

$$COP = \frac{\dot{m}_r \cdot q_o}{\dot{m}_r \cdot w_C + \dot{m}_{ms} \cdot w_{c,ms}} = \frac{q_o}{w_C + \frac{\Delta h_{sub}}{q_{o,ms}}} \quad (19)$$

Modifications of capacity due to the use of the mechanical subcooling cycle, since no geometric displacement of the CO₂ compressor is fixed, are evaluated as a percentage variation, as expressed by Equation (20), where variables with asterisk (*) correspond to the operation with the mechanical subcooling cycle and without to the operation of the transcritical cycle. The volumetric efficiency, computed with relation (9), is evaluated for the single-stage cycles with the total compression ratio and for the two-stage cycle with the low-stage compression ratio.

$$\Delta\dot{Q}_o = \frac{\dot{Q}_o^* - \dot{Q}_o}{\dot{Q}_o} \cdot 100 = \left(\frac{\eta_v^*}{\eta_v} \cdot \frac{q_o^*}{q_o} - 1 \right) \cdot 100 \quad (20)$$

3. Energy performance analysis

In this section, we present and discuss the effect of using a dedicated mechanical subcooling cycle in a CO₂ transcritical refrigeration plant on its energy performance using the simplified model described in section 2. For the first part of the analysis, we use as refrigerant for the MS cycle propane (R290). First, the modification of the optimum operating conditions due to the use of the MS cycle are discussed, next the energy performance improvement over different operating conditions is presented, and finally, different refrigerant options for the MS cycle are discussed.

For the simulations we have considered that the plant always operates in transcritical conditions, therefore, the minimum operating pressure considered has been 74 bar. The results could be extended to subcritical operation of the CO₂ cycle, but the performance improvements will be lower than in the transcritical region, as discussed below.

3.1. Optimum operating conditions

The CO₂ transcritical cycle has as most important parameter to be controlled the value of the heat rejection pressure, which presents an optimum value, as analysed experimentally by Cabello et al. (2008). The outlet temperature of the gas-cooler little depends on the operating pressure, since it mainly depends on the approach temperature achieved in the gas-cooler. Accordingly, the refrigerant at the exit of the gas-cooler will be in the isotherm defined by the environment temperature plus the approach temperature in the gas-cooler at the pressure defined by the regulating device.

To use the MS cycle in a CO₂ transcritical cycle, as mentioned before, two strategies are possible. First, it is possible to subcool CO₂ at the same pressure than the optimum pressure of the transcritical cycle, or second, subcool CO₂ at the optimum pressure defined by the maximum combined COP of the MS cycle and the transcritical cycle, Equation (19). Both situations are represented in Figure 3 for an evaporating temperature of -5 °C and an environment temperature of 35 °C for a degree of subcooling in the subcooler (SUB) of 4 °C. If the subcooling is done at the same pressure than that of the transcritical cycle (dotted line) the COP is increased because the specific cooling capacity is incremented, but if the pressure is reduced (dashed line), additional benefits are obtained, mainly reductions of the compression ratio and of

the specific compression work in the transcritical cycle. This reasoning can also be observed in Figure 4, where the COP evolution, Equation (19), versus the gas-cooler pressure is presented for different degrees of subcooling. As it can be observed, the introduction of the subcooling reduces the optimum heat rejection pressure, incrementing the COP due to the increment of the specific cooling capacity and to the reduction of the specific compression work. Also, in Figure 4, it can be observed that the COP increase has not a linear dependence on the SUB, the COP increments are higher for low SUB values. Also, SUB softens the reduction of the COP when operating at pressures below the optimum value. Another important aspect is the power consumption of the MS cycle to produce the subcooling. This value is represented as a ratio between the consumption of the MS cycle versus the consumption of the CO₂ cycle, Equation (18). It can be observed in Figure 4 that the power consumption needed for the MS cycle is below a 20% of that in the main cycle at the optimum conditions, but it increases significantly for pressures below the optimum value. Thus, operating below the optimum values will need to oversize the MS cycle and it would not be convenient. Next, the specific cooling capacity of the cycle, Equation (8), and the enthalpy difference in the subcooler, Equation (7), are shown in Figure 5. It needs to be pointed out that for operation below the optimum point the enthalpy difference in the subcooler is high, therefore, large heat exchangers would be also needed. In addition to the increment of the specific cooling capacity, the use of the mechanical subcooling also allows reducing the compression ratio, its combination is traduced to increments of the cooling capacity. The percentage increments, Equation (20), of cooling capacity due to the use of the mechanical subcooling are presented in Figure 6. It can be observed that using the mechanical subcooling it can be increased the capacity of the transcritical cycle, specially for operating pressures below the optimum, where the transcritical cycle suffers drastic reductions of capacity (Cabello et al., 2008).

Accordingly, to use the MS cycle in combination with a CO₂ transcritical cycle, we can affirm that it must be operated at its optimum pressure, which is below from that of pure transcritical cycle, so the high pressure regulating devices must be modified. Furthermore, regarding the subcooling degree to be provided to the CO₂ transcritical cycle, it needs to be mentioned that although any degree of subcooling is possible, the practical limit would depended on the refrigeration system considered. For centralized systems, the maximum subcooling degree would be equal to the approach temperature between gas-cooler outlet and the environment (in this case 5 °C), since higher subcooling degrees will be lost due to heat transfer to the environment during the distribution of the refrigerant. For stand-alone systems this subcooling degree can be increased.

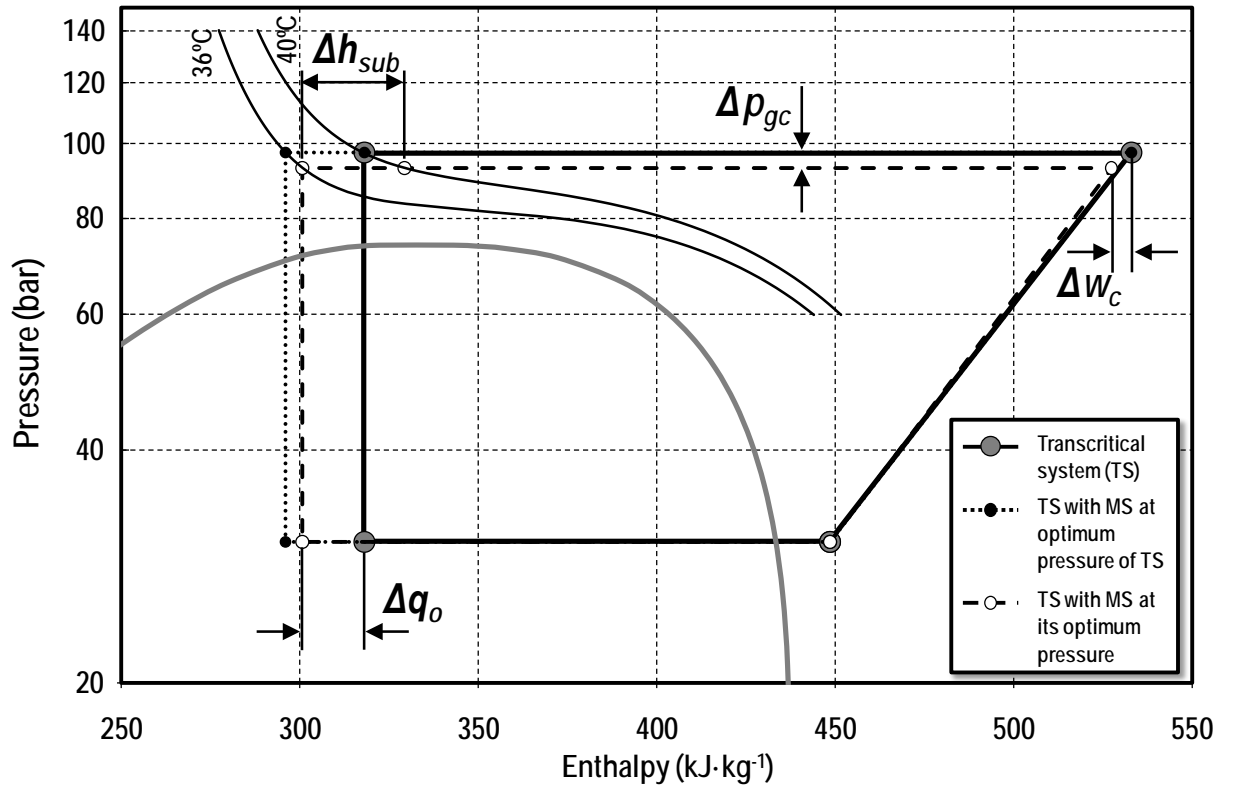

Figure 3. p-h diagram of the pure CO₂ transcritical cycle and its modifications using the MS cycle

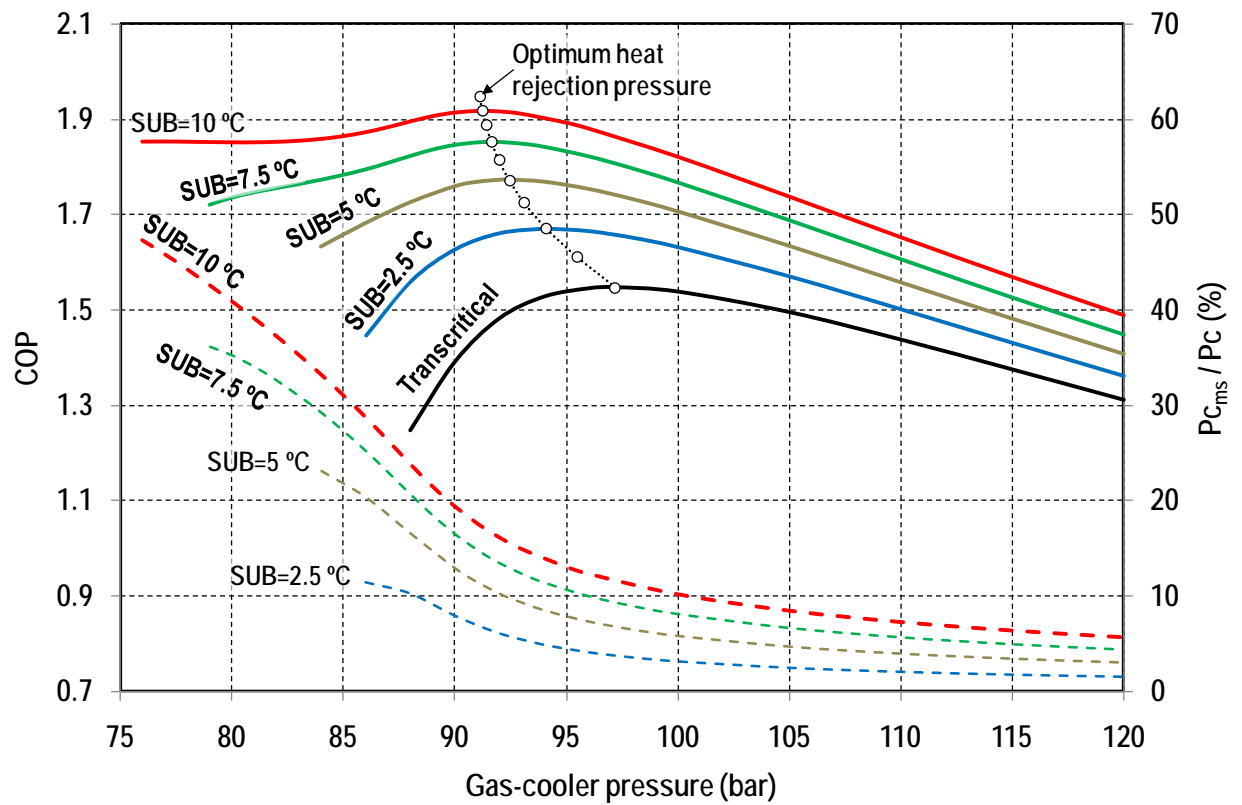

Figure 4. COP (continuous line, left axis) and ratio of power consumption (dashed line, right axis) vs. gas-cooler pressure for different subcooling degrees in the subcooler. ($T_o=-5^\circ\text{C}$, $T_{env}=35^\circ\text{C}$)

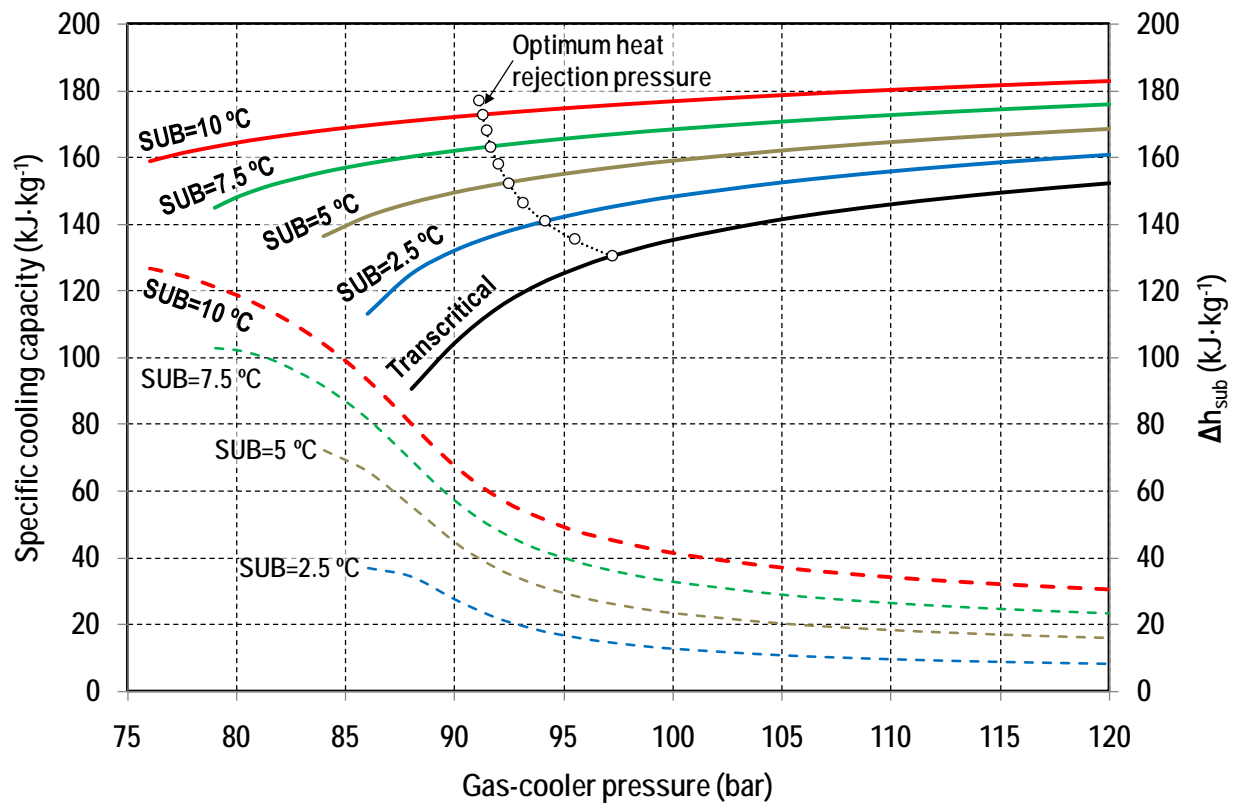

Figure 5. Specific cooling capacity (continuous line, left axis) and enthalpy difference in subcooler (dashed line, right axis) vs. gas-cooler pressure for different subcooling degrees in the subcooler. ($T_o = -35^\circ\text{C}$, $T_{env} = 35^\circ\text{C}$)

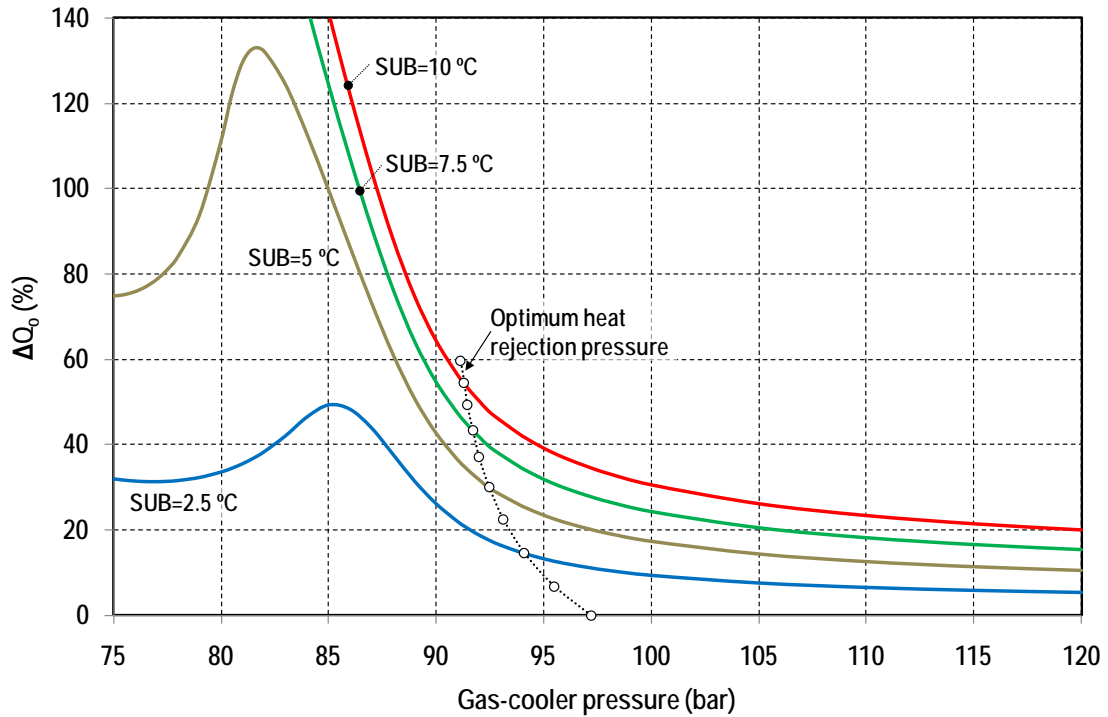

Figure 6. Increment of cooling capacity regards transcritical operation vs. gas-cooler pressure for different subcooling degrees in the subcooler ($T_o = -35^\circ\text{C}$, $T_{env} = 35^\circ\text{C}$)

3.2. Performance improvement with dedicated mechanical subcooling

Once the optimum operating conditions have been established, in this subsection the performance improvement of the CO_2 transcritical refrigeration system with the dedicated mechanical subcooling cycle is analysed. For the analysis, we have considered the three evaporating levels of commercial refrigeration: 5°C for high-temperature, -5°C for medium-temperature and -30°C for low-temperature. The simulations for high and medium-temperature are done with a single-stage compression system and for low-temperature with the double-stage system with intercooler (Figure 2). The evaluation covered environment temperatures from 20 to 35°C in which three subcooling degrees are considered. All the data here presented has been evaluated at the optimum heat rejection pressure, as previously discussed. In this subsection the refrigerant used for the MS cycle has been propane.

In Figure 7, the COP evolutions of the transcritical cycle with MS, Equation (19), are represented for the three evaporating levels versus the environment temperature for three different subcooling degrees, and in Figure 8, the COP percentage increments versus the ones obtained with the transcritical system. As it can be observed in Figure 7, for the three evaporating levels and for all environment temperatures, the use of

the MS cycle improves the efficiency of the system, being the highest improvements obtained for an evaporating level of $-5\text{ }^{\circ}\text{C}$. For example, for an environment temperature of $30\text{ }^{\circ}\text{C}$ and a subcooling degree of $5\text{ }^{\circ}\text{C}$, the COP improvements are of 9.5% at $5\text{ }^{\circ}\text{C}$, of 13.7% at $-5\text{ }^{\circ}\text{C}$ and of 13.1% at $-30\text{ }^{\circ}\text{C}$. Although the MS is beneficial for all the range, it can be clearly observed the environment temperature from which is desirable to use the MS cycle in Figure 8. For environment temperatures higher than $25\text{ }^{\circ}\text{C}$ approximately the MS cycle produces high increments of the COP of the system, being thus recommended for warm and hot countries. The reason of this increment is presented in Figure 9. For high environment temperatures, the use of the MS cycle also allows the optimum pressure of the transcritical system to be reduced, that producing an additional reduction of the power consumption in the CO_2 compressors and therefore a highest improvement of the COP. Regarding the reductions of the optimum pressure, they are higher when lower the evaporating level is. That is in agreement with the theoretical results of Liao et al. (2000) and Sarkar et al. (2004), who state that the optimum heat rejection pressure of CO_2 transcritical systems is higher when lower the evaporating level is, accordingly, when lowest the evaporating temperature is more reduction of the working pressure is achieved by the MS cycle. The reductions of optimum pressure for an environment temperature of $30\text{ }^{\circ}\text{C}$ and a subcooling degree of $5\text{ }^{\circ}\text{C}$ are of 1.9 bar at $5\text{ }^{\circ}\text{C}$, of 3 bar at $-5\text{ }^{\circ}\text{C}$ and of 7.5 bar at $-30\text{ }^{\circ}\text{C}$. Next, in Figure 10, the ratio between the power consumption of the MS cycle regards the power consumption of the CO_2 transcritical cycle, Equation (18), is presented for the three evaporating levels. This ratio increases as the evaporating level rises and for highest subcooling degrees and has an abrupt increase for environment temperatures around $25\text{ }^{\circ}\text{C}$, where the optimum operating pressure is reduced. Its reason is that the reduction of the optimum pressure increases the CO_2 mass flow rate, and therefore, to achieve the same subcooling degree the needed refrigerant in the MS cycle increases. For example, at an environment temperature of $30\text{ }^{\circ}\text{C}$ and a subcooling degree of $5\text{ }^{\circ}\text{C}$ this ratio is 13.8% at $5\text{ }^{\circ}\text{C}$, 9.5% at $-5\text{ }^{\circ}\text{C}$ and 4.4% at $-30\text{ }^{\circ}\text{C}$. Finally, in Figure 11, the percentage increment of the cooling capacity versus transcritical operation is presented. This increment of capacity is the result of the increase of the specific cooling capacity (Figure 5) and the increment of refrigerant mass flow rate due to the high-pressure reduction (Figure 9). The combination results always positive, but the highest increments are provided for environment temperatures over $25\text{ }^{\circ}\text{C}$. Regarding the cooling capacity, at an environment temperature of $30\text{ }^{\circ}\text{C}$ and a subcooling degree of $5\text{ }^{\circ}\text{C}$ it is enhanced by 20.7% at $5\text{ }^{\circ}\text{C}$, 19.7% at $-5\text{ }^{\circ}\text{C}$ and 12.7% at $-30\text{ }^{\circ}\text{C}$.

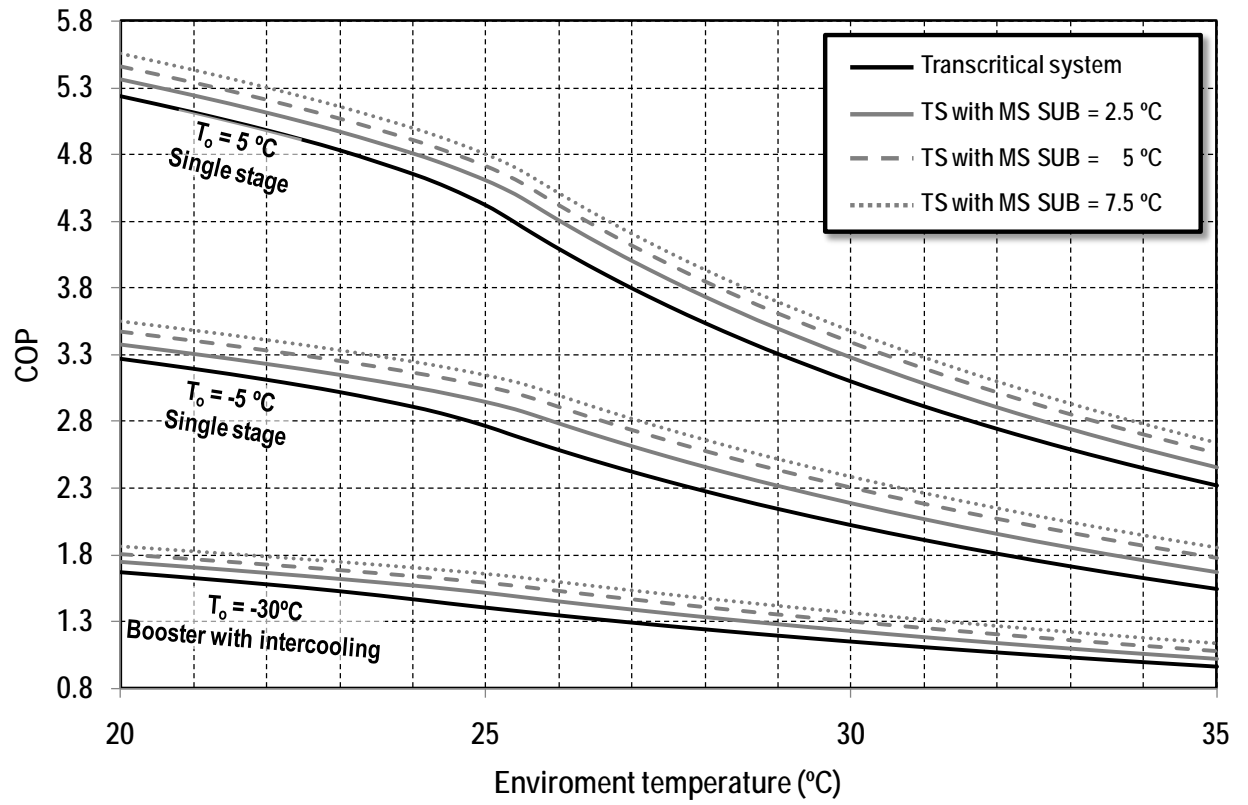

Figure 7. COP of the transcritical and transcritical with MS vs. environment temperature

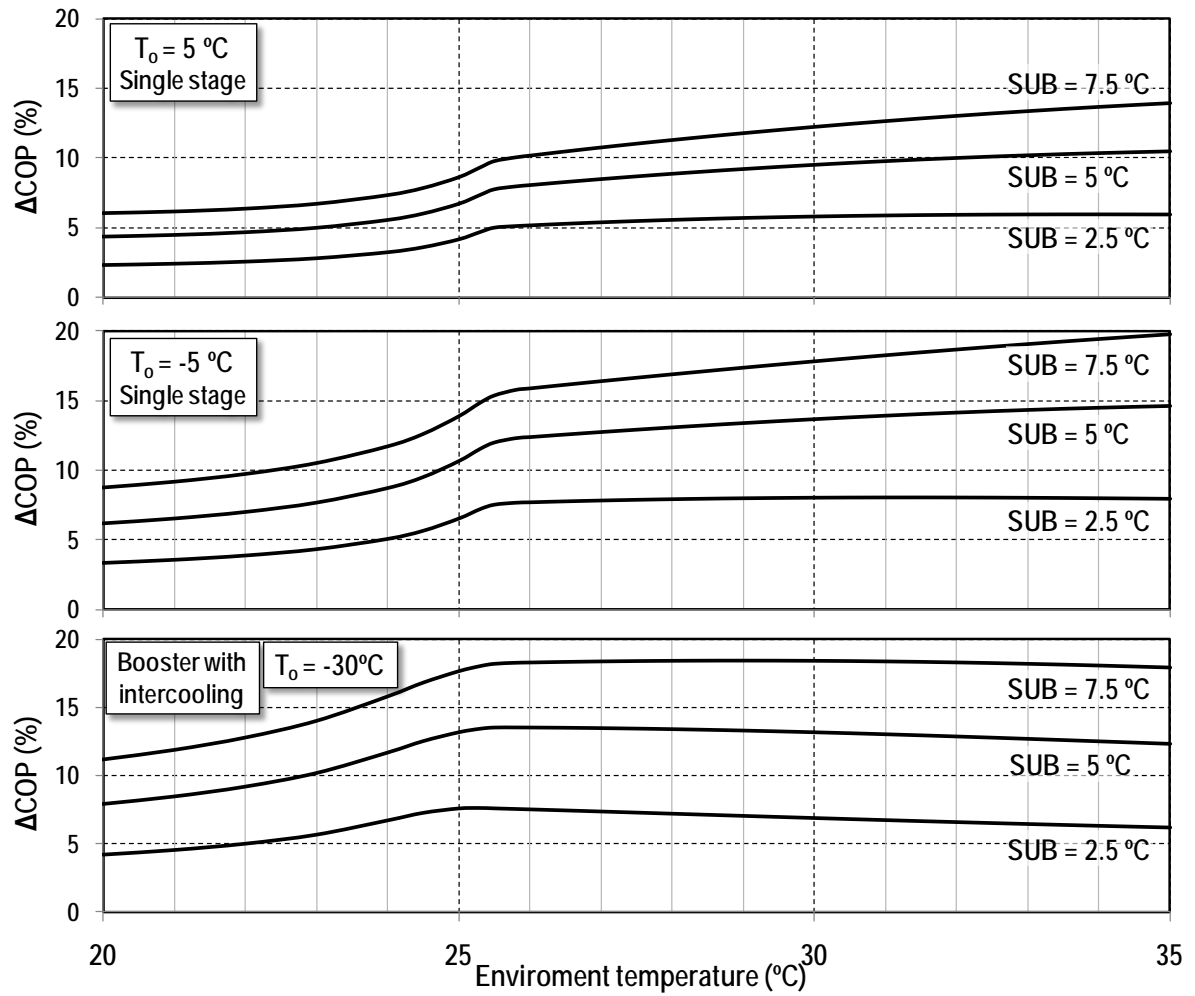

Figure 8. COP increment versus the transcritical system for different subcooling degrees

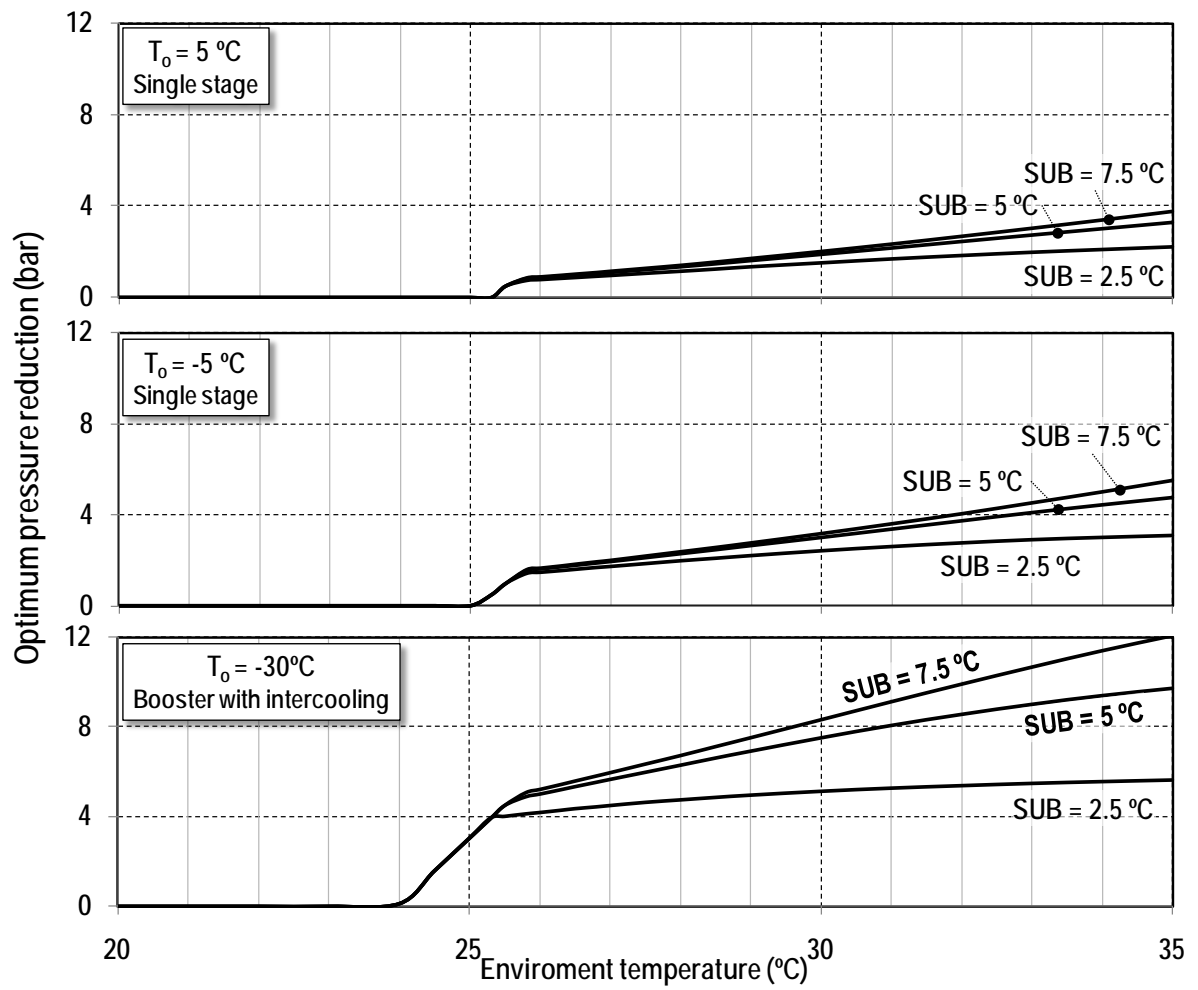

Figure 9. Optimum pressure reduction versus the transcritical systems for different subcooling degrees

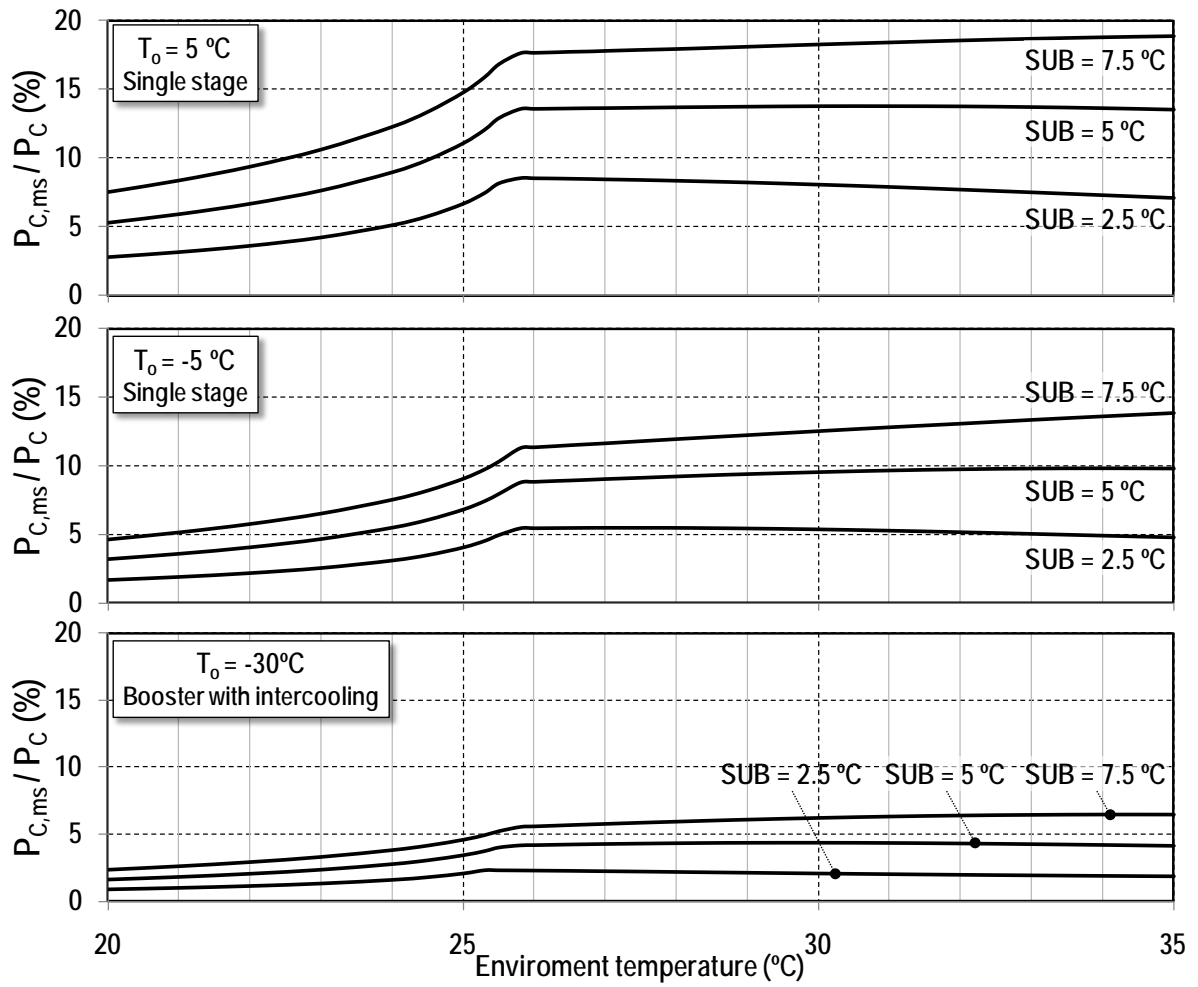

Figure 10. Ratio of power consumption of the MS cycle and the CO₂ transcritical cycle for different subcooling degrees

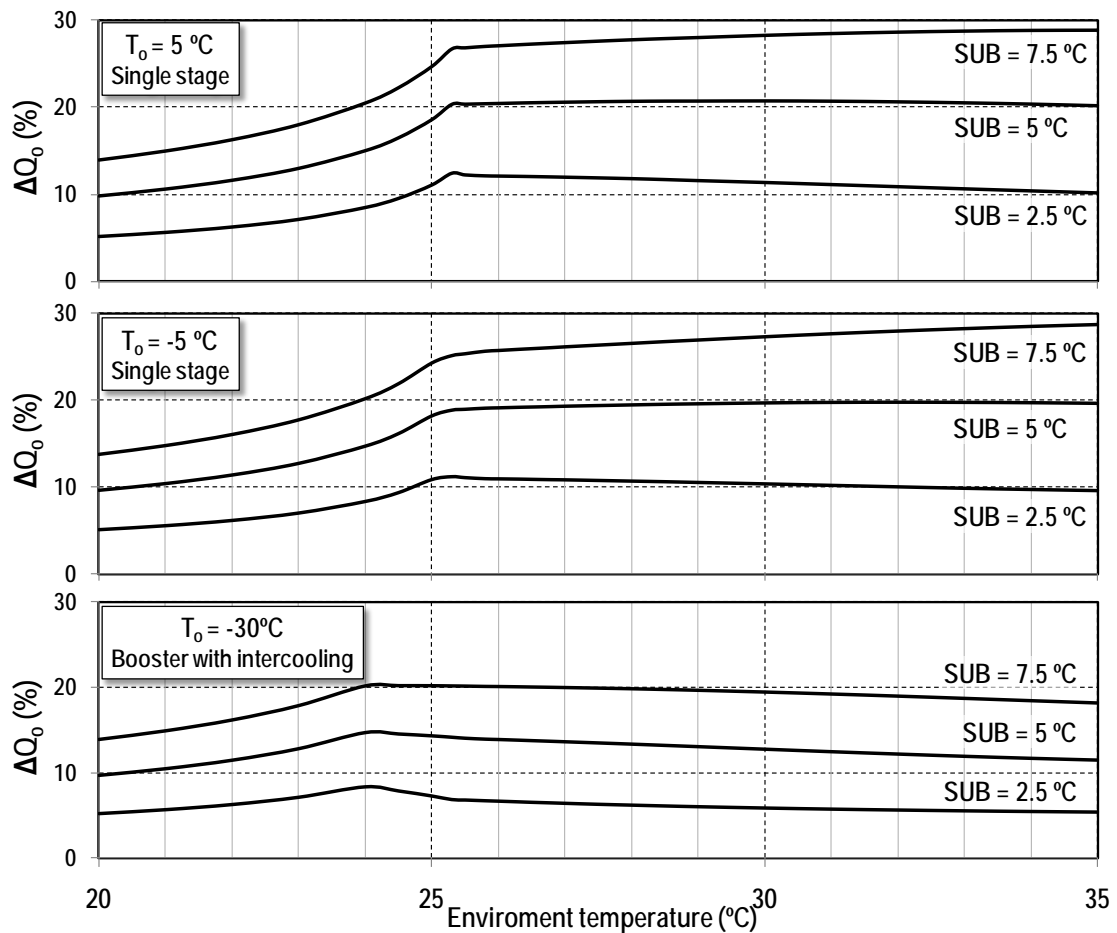

Figure 11. Percentage increment of cooling capacity versus the transcritical system for different subcooling degrees

3.3. Refrigerant for the dedicated mechanical subcooling cycle

The performance improvement of the CO_2 transcritical cycle with the use of a dedicated mechanical subcooling system in the previous sections has been analysed considering R290 (propane) as refrigerant for the MS cycle. In this subsection, the performance improvement achieved with the MS cycle is expanded to different possible refrigerants for which compressor technology is available.

In Figure 12 the COP increment due to the use of the MS cycle is presented for the three evaporating levels and different environment temperatures of 6 refrigerants in the MS cycle with a subcooling degree of CO_2 of 5 °C. As it can be observed the achieved improvements are similar for all the refrigerants. The unique refrigerants which show degradation in the improvements are R1234yf and R134a at environment temperatures above 30 °C. All hydrocarbons considered allow similar improvements.

In Figure 13 the ratio of power consumptions on the cycles, Equation (18), with the different refrigerants is presented. It can be observed that no appreciable differences between the refrigerants can be expected, except for the R1234yf and R134a at high environment temperatures, where this ratio is slightly higher than for other fluids.

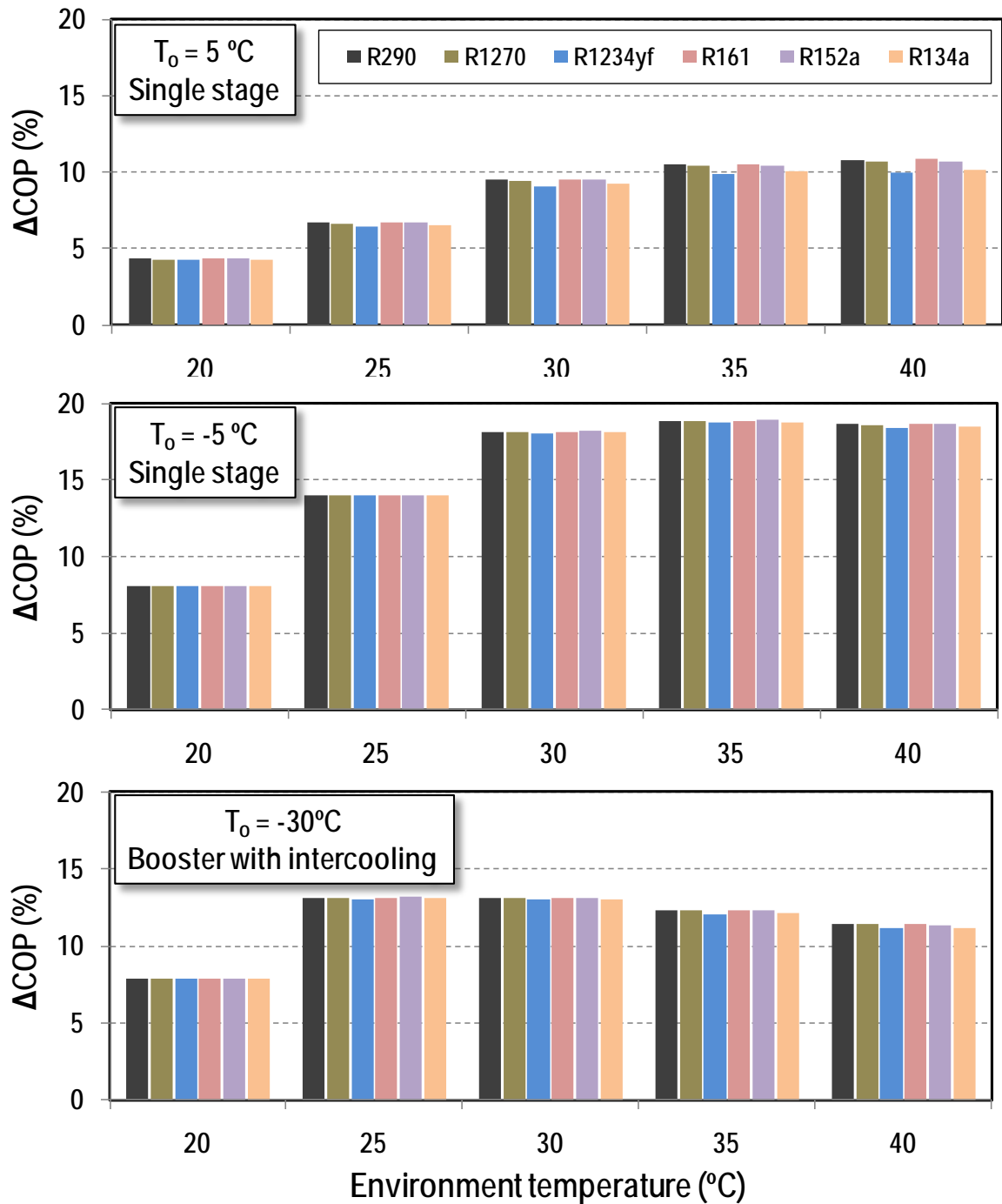

Figure 12. COP improvement with MS cycle for different refrigerants in the MS cycle. SUB=5 °C

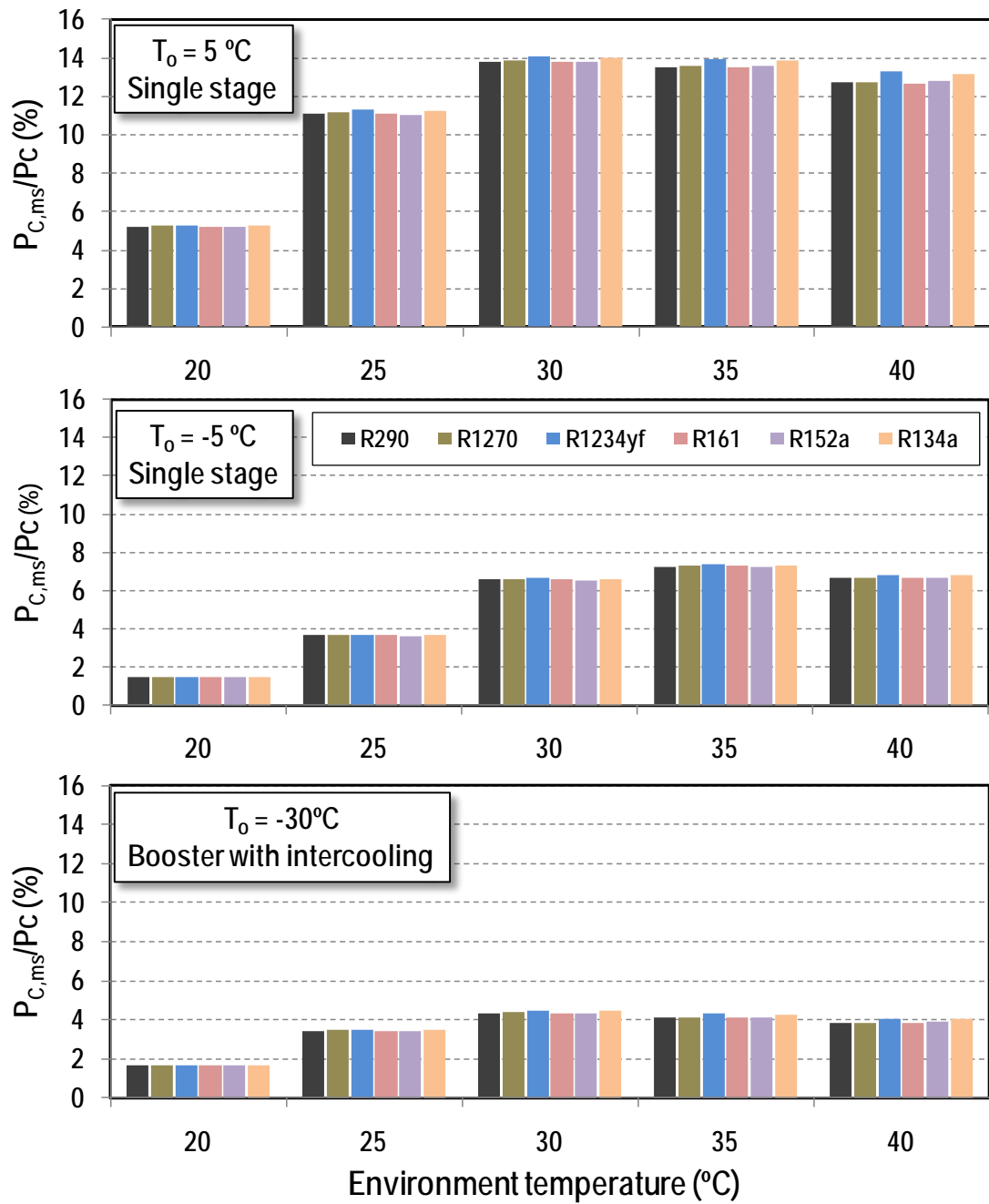

Figure 13. Ratio of power compression in the MS cycle and the transcritical with different refrigerants SUB=5 °C

4. Conclusions

In this paper the possibilities of enhancing the energy performance of CO₂ transcritical refrigeration systems using a dedicated mechanical subcooling cycle (MS) have been studied theoretically. Using a simplified model of the refrigeration cycles under close assumptions to reality it has been studied the modifications of the optimum operating conditions of the transcritical cycle introduced by the use of the MS cycle. Also the performance improvement for three evaporating levels over a wide range of environment temperatures for different subcooling degrees has been quantified. And additionally, the results have been extended to different refrigerants in the MS cycle.

It has been observed that when using the MS cycle the optimum pressure of the transcritical system can be reduced, being this the correct strategy instead of applying the subcooling at the same optimum pressure of the transcritical cycle. Its use allows increasing the COP and the capacity of the system in all operating conditions.

About the energy improvement in different operating conditions, it has been studied the effect of the MS cycle at different evaporating levels with different compressor technologies. For 5°C and -5°C with a single-stage compression system and for -30°C with a double-stage cycle with intercooling. The operating range in which more benefit is obtained using the MS cycle is for environment temperatures above 25°C for all the evaporation levels, but the increments are higher for medium temperature applications. For an operation at 30 °C with a subcooling degree equal to the approach temperature in the gas-cooler the maximum expected increments in COP are of 9.5% at 5°C, of 13.7% at -5°C and of 13.1% at -30°C. The ratio of power consumption of the MS cycle regards the transcritical for these conditions reaches 13.8% at 5 °C, 9.5% at -5 °C and 4.4% at -30°C. For this operating condition, the increments of cooling capacity reached 20.7% at 5 °C, 19.7% at -5 °C and 12.7% at -30°C.

Furthermore, it has been observed that for the MS cycle any refrigerant for which compressor technology is available can be used, since the COP improvements are similar among them.

Finally, as general conclusion of the results, we can affirm that the use of the dedicated mechanical subcooling cycle as a way to improve the performance of CO₂ transcritical plants needs to be considered, specially for warm and hot countries. It can be used as a support system to favour the implantation of transcritical systems in this regions, in which pure CO₂ transcritical systems are not completely energy competitive. Additionally, it needs to be mentioned that the results are theoretical and an experimental studies are needed to quantify exactly the improvements that can be achieved.

5. Acknowledgements

The authors gratefully acknowledge Jaume I University of Spain, who financed the present study through the research project P1-B2013-10.

6. References

- Apra, C., Greco, A., Maiorino, A., 2015. The application of a desiccant wheel to increase the energetic performances of a transcritical cycle. *Energy Conversion and Management* 89, 222-230.
- Apra, C., Maiorino, A., 2008. An experimental evaluation of the transcritical CO₂ refrigerator performances using an internal heat exchanger. *International Journal of Refrigeration* 31, 1006-1011.
- Apra, C., Maiorino, A., 2009. Heat rejection pressure optimization for a carbon dioxide split system: An experimental study. *Applied Energy* 86, 2373-2380.
- Arora, A., Singh, N.K., Monga, S., Kumar, O., 2011. Energy and exergy analysis of a combined transcritical CO₂ compression refrigeration and single effect H₂O-LiBr vapour absorption system. *International Journal of Exergy* 9, 453-471.
- Cabello, R., Sánchez, D., Llopis, R., Torrella, E., 2008. Experimental evaluation of the energy efficiency of a CO₂ refrigerating plant working in transcritical conditions. *Applied Thermal Engineering* 28, 1596-1604.
- Cabello, R., Sánchez, D., Patiño, J., Llopis, R., Torrella, E., 2012. Experimental analysis of energy performance of modified single-stage CO₂ transcritical vapour compression cycles based on vapour injection in the suction line. *Applied Thermal Engineering* 47, 86-94.
- Cavallini, A., Cecchinato, L., Corradi, M., Fornasieri, E., Zilio, C., 2005. Two-stage transcritical carbon dioxide cycle optimisation: A theoretical and experimental analysis. *International Journal of Refrigeration* 28, 1274-1283.
- Cavallini, A., Corradi, M., Fornasieri, E., 2007. Experimental investigation on the effect of the Internal Heat Exchanger and Intercooler effectiveness of the energy performance of a two-stage transcritical carbondioxide cycle., in: IIR (Ed.), 22nd International Congress of Refrigeration, Beijing, China.
- Cho, H., Baek, C., Park, C., Kim, Y., 2009. Performance evaluation of a two-stage CO₂ cycle with gas injection in the cooling mode operation. *International Journal of Refrigeration* 32, 40-46.
- European Commission, 2014. Regulation (EU) No 517/2014 of the European Parliament and of the Council of 16 April 2014 on fluorinated greenhouse gases and repealing Regulation (EC) No 842/2006.

- Ge, Y.T., Tassou, S.A., 2009. Control optimisation of CO₂ cycles for medium temperature retail food refrigeration systems. *International Journal of Refrigeration* 32, 1376-1388.
- He, Y., Deng, J., Zhang, Z., 2014. Thermodynamic study on a new transcritical CO₂ ejector expansion refrigeration system with two-stage evaporation and vapor feedback. *HVAC&R Res.* 20, 655-664.
- Kim, M.H., Pettersen, J., Bullard, C.W., 2004. Fundamental process and system design issues in CO₂ vapor compression systems. *Progress in Energy and Combustion Science* 30, 119-174.
- Lee, J.S., Kim, M.S., Kim, M.S., 2014. Studies on the performance of a CO₂ air conditioning system using an ejector as an expansion device. *International Journal of Refrigeration* 38, 140-152.
- Lemmon, E.W., Huber, M.L., McLinden, M.O., 2010. REFPROP, NIST Standard Reference Database 23, v.9. National Institute of Standards, Gaithersburg, MD, U.S.A.
- Li, M., Ma, Y., Guan, H., Li, L., 2004. Development and Experimental Study of CO₂ Expander in CO₂ Supercritical Refrigeration Cycles. *International Journal of Green Energy* 1, 89-99.
- Liao, S.M., Zhao, T.S., Jakobsen, A., 2000. A correlation of optimal heat rejection pressures in transcritical carbon dioxide cycles. *Applied Thermal Engineering* 20, 831-841.
- Llopis, R., Sánchez, D., Sanz-Kock, C., Cabello, R., Torrella, E., 2015. Energy and environmental comparison of two-stage solutions for commercial refrigeration at low temperature: Fluids and systems. *Applied Energy* 138, 133-142.
- Peñarrocha, I., Llopis, R., Tárrega, L., Sánchez, D., Cabello, R., 2014. A new approach to optimize the energy efficiency of CO₂ transcritical refrigeration plants. *Applied Thermal Engineering* 67, 137-146.
- Qureshi, B.A., Inam, M., Antar, M.A., Zubair, S.M., 2013. Experimental energetic analysis of a vapor compression refrigeration system with dedicated mechanical sub-cooling. *Applied Energy* 102, 1035-1041.
- Qureshi, B.A., Zubair, S.M., 2012a. The effect of refrigerant combinations on performance of a vapor compression refrigeration system with dedicated mechanical sub-cooling. *International Journal of Refrigeration* 35, 47-57.
- Qureshi, B.A., Zubair, S.M., 2012b. The impact of fouling on performance of a vapor compression refrigeration system with integrated mechanical sub-cooling system. *Applied Energy* 92, 750-762.
- Sánchez, D., Patiño, J., Llopis, R., Cabello, R., Torrella, E., Fuentes, F.V., 2014. New positions for an internal heat exchanger in a CO₂ supercritical refrigeration plant. Experimental analysis and energetic evaluation. *Applied Thermal Engineering* 63, 129-139.
- Sánchez, D., Torrella, E., Cabello, R., Llopis, R., 2010. Influence of the superheat associated to a semihermetic compressor of a transcritical CO₂ refrigeration plant. *Applied Thermal Engineering* 30, 302-309.

- Sarkar, J., 2013. Performance optimization of transcritical CO₂ refrigeration cycle with thermoelectric subcooler. *Int. J. Energy Res.* 37, 121-128.
- Sarkar, J., Bhattacharyya, S., Gopal, M.R., 2004. Optimization of a transcritical CO₂ heat pump cycle for simultaneous cooling and heating applications. *International Journal of Refrigeration* 27, 830-838.
- Shecco Publications, 2014. Guide 2014: Natural refrigerants continued growth & innovation in Europe. In: <http://publication.shecco.com/publications/view/2014-guide-natural-refrigerants-europe>, November 2014.
- Torrella, E., Sánchez, D., Llopis, R., Cabello, R., 2011. Energetic evaluation of an internal heat exchanger in a CO₂ transcritical refrigeration plant using experimental data. *International Journal of Refrigeration* 34, 40-49.
- Yang, J.L., Ma, Y.T., Liu, S.C., 2007. Performance investigation of transcritical carbon dioxide two-stage compression cycle with expander. *Energy* 32, 237-245.
- Zubair, S.M., 1994. Thermodynamics of a vapor-compression refrigeration cycle with mechanical subcooling. *Energy* 19, 707-715.