

3D PRINTED ORTHOSIS DESIGN

JUDIT AGUADO PÉREZ

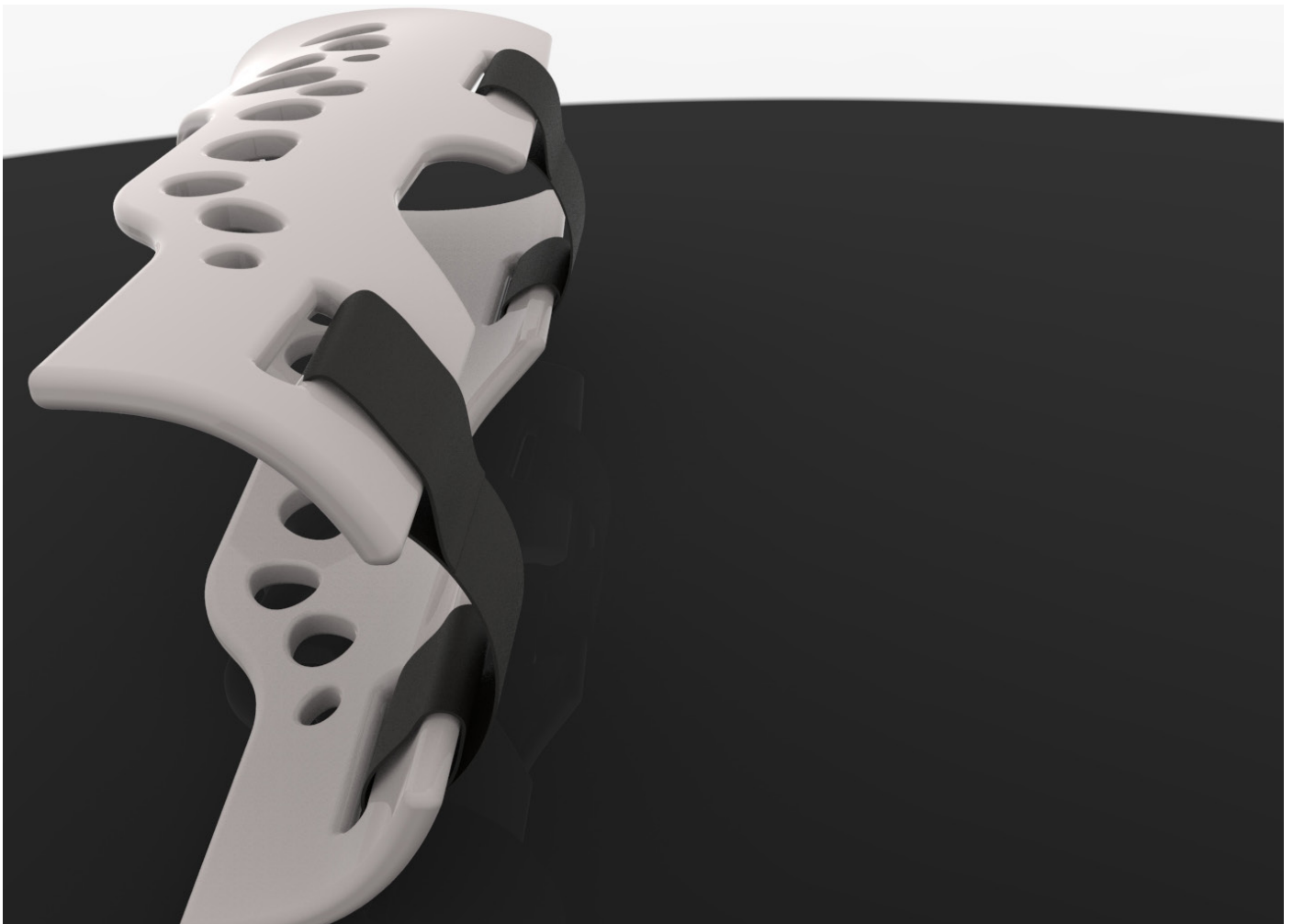

INDEX

1. PROJECT DEFINITION	4
2. TECHNICAL LITERATURE	
2.1. WHAT'S AN ORTHOSIS?	6
2.2. MEDICAL PROBLEMS	8
2.3. MATERIALS	10
2.4. MANUFACTURING	11
2.5. CREATION PROCESS	14
2.6. DVANTAGES AND DISADVANTAGES OF 3D PRINTING	15
2.7. MASS PRODUCTION OR PERSONALIZED ORTHOSIS	16
3. STATE OF ART	17
4. FUNCTIONAL REQUIREMENTS	35
5. FIRST SKETCHES	38
6. DESIGN PROCESS	
6.1. MEASURE	52
6.2. JUSTIFICATION OF THE MATERIAL CHOICE	54
6.3. MANUFACTURING PROCESS USED	55
6.4. CONNECTING ELEMENTS	56
7. 3D MODEL	
7.1. CONSTRUCTION	58
8. DRAWINGS	62
..	
9. LOAD SIMULATION	65
10. RENDERING	73
11. FINAL CONCLUSIONS	81
12. FUTURE POSSIBILITIES	82
13. LITERATURE REFERENCES	83

PROJECT DEFINITION

1

3d printing offers a promising possibility for fitting orthosis (wrist splints, corsets, etc.), orthotics and prosthesis design to personal features. The candidate has to make a detailed research work on the topic, contacting with orthetic specialists about the needs, fabricating possibilities and features, design tools and current applications. He/she has to propose some application field for production and design such a product in achievable price for ordinary people; identify the main function of the equipment and requirement to fulfil, and propose for that case a design and production process.

This project is titled "3D printed orthosis design". The purpose of the present study is to define and describe the new product that has been developed. This product aims to present a new concept of 3D printed wrist orthosis. The aim of this project is to create a product which is able to solve medical problems such as tendinitis, carpal tunnel syndrome, wrist sprains and so on. Nowadays, these problems are affecting a large number of the population.

One of the most important aspects to consider is the aesthetics. As it is known, an orthosis is something that can not be hidden. This is why it was wanted to look for an innovative product as the same as simple in order to anybody who will wear with out any qualms.

As said before, the production method will be the additive manufacturing which not only means an aesthetic improvement but it will be much easier to use and to place, besides allowing the doctor a better help for the recovery of the patient. It also will avoid problems that the traditional plaster had, as for example sweat, itching or the inability to take a shower...

Futhermore, 3D printing improves the quality of the pieces, speed up the production process and advances in the reduction of costs which is a very important factor of the society nowadays. So one of the requirements to achieve is to design an affordable orthosis for everyone.

TECHNICAL LITERATURE

2

This section will show the studies and the analysis of the relevant resources related to the technical documentation on the field of orthosis; embracing the different types already known, medical importance of the different fields, technological base, manufacturing processes and finally the design process of a mass produced and personalized orthosis.

In this point is also going to be studied the evolution of the materials, starting from the traditional plaster until the new polymers used nowadays. The use of new materials leads to the appearance of new manufacturing techniques. One of this new techniques is the 3D printing, which is becoming more important due to the numerous advantages presented against traditional processes in the field of medicine over the years.



2. TECHNICAL LITERATURE



2.1. WHAT IS AN ORTHOSIS?







An orthosis is “an externally applied device used to modify the structural and functional characteristics of the neuromuscular and skeletal system”. An orthotist is the primary medical clinician responsible for the prescription, manufacture and management of orthosis. The main functionality are:

- Control, guide, limit and/or immobilize an extremity, joint or body segment for a particular reason.
- Restrict movement in a given direction.
- Assist movement generally.
- Reduce weight bearing forces for a particular purpose.
- Aid rehabilitation from fractures after the removal of a cast.
- Otherwise correct the shape and/or function of the body, to provide easier movement capability or reduce pain.



Orthosis are classified by an acronym describing the anatomical joints which they contain. Due to that, there are three general groups that include all kinds of orthosis, which are the following ones:

SPINAL		
Spine Orthotic	Is applied to the body to limit the motion of, correct deformity in, reduce axial loading on, or improve the function of a particular spinal segment of the body.	
Cervical Orthosis	Are used to support stable spine conditions.	
Cervical Thoracic Orthosis (CTOs)	CTOs are used in minimally unstable fractures. All CTO's tend to control flexion better than extension.	

UPPER LIMB		
Arm	Orthosis are devices applied externally to restore or improve functional and structural characteristics of the musculoskeletal and nervous systems. There are: <ul style="list-style-type: none"> • Static orthosis • Dynamic/functional orthosis 	
Wrist/Hand	Used to provide grasp and release despite some degree of hand paralysis.	

LOWER LIMB		
Knee Orthosis (KO) Brace	Is a brace worn to strengthen the knee. Works by relieving pressure off the part of the knee joint that is affected by ailments such as arthritis or osteoarthritis.	
Ankle Foot Orthosis (AFO)	The joint in the orthosis assumes the function of the ankle joint or those functions the foot is not able to perform on its own anymore (lifting).	
Foot Orthotic	For a misshapen or deformed foot as well as to help relieve areas of pressure on the foot. It is designed to support the foot by applying pressure to areas to encourage an appropriate gait.	
Diabetic Shoes and Custom Shoe Inserts	For who suffer from certain complications affecting the foot. Qualifying complications include neuropathy, calluses, poor circulation and a history of ulceration.	
KAFO (Knee Ankle Foot Orthosis)	A knee ankle foot orthosis extends over the knee. The focus is on the joint used at knee height.	
Hips	Used after a total hip replacement in order to prevent the motions of hip flexion, adduction and internal rotation that can cause dislocation.	

Ending the classification, it must be said that concerning to the upper limb the rank of classification can be extended, depending on the movement, it can be differentiated two others types, which are collected in the following table:

MOVEMENT TYPE		
Static orthosis	Provide support, stabilize, protect and immobilize. Rest. Does not allow movement.	
Dynamic/functional orthosis	Use parts that move to allow, guide or restore specific movements. Control of motion. Aid in alignment and wound healing.	

2.2. MEDICAL PROBLEMS

As we saw before, the concept of orthosis has been studied, as well as her functions, or the different types that exist in the market. This project aims to develop a study of design of a personalized wrist orthosis, so the different medicals problems which the orthosis has to face and is able to solve, must be examined.

The wrist is a joint in itself, so it is very much susceptible to injury. This susceptibility is further increased by the fact that the wrist is commonly used and easy to overuse. We need our hands to function in our day-to-day, so even a minimum pain, it should not be ignored, since if left untreated, this could lead to arthritis and other medical conditions to the wrist that could be more problematic. Wrist injuries are classified into two categories:

- **Acute Injury:** the most common acute wrist injuries are joint dislocations, muscle strains, sprains, broken bones, tendon inflammation, and ligament tears.
- **Chronic Injury:** they are stress-induced and can therefore lead to tendon irritation and inflammation, nerve injury, dislocation, and overuse stress fractures.

Wrist pain can be as common as a sprain or a start of something as severe as carpal tunnel syndrome, so for to know a little more about this, here is a list of the most common wrist injuries, their symptoms, how they should be handled and what can be done to prevent it:

Wrist Sprains: this is probably the most common among the wrist injuries. It is a direct injury to the ligament as a result from either being outstretched or torn. This usually happens when someone falls down the on an outstretched hand. Thus, one experiences almost immediate pain, swelling, and bruising or discoloration. Wrist sprains are divided into three degrees.

Treatment for wrist sprains is RICE that stands for rest, ice, compress, and elevate along. If the sprain is moderate, it will have to be immobilized with brace, splints, or slings, but if it is severe, surgery might be warranted with physical therapy and braces afterwards.

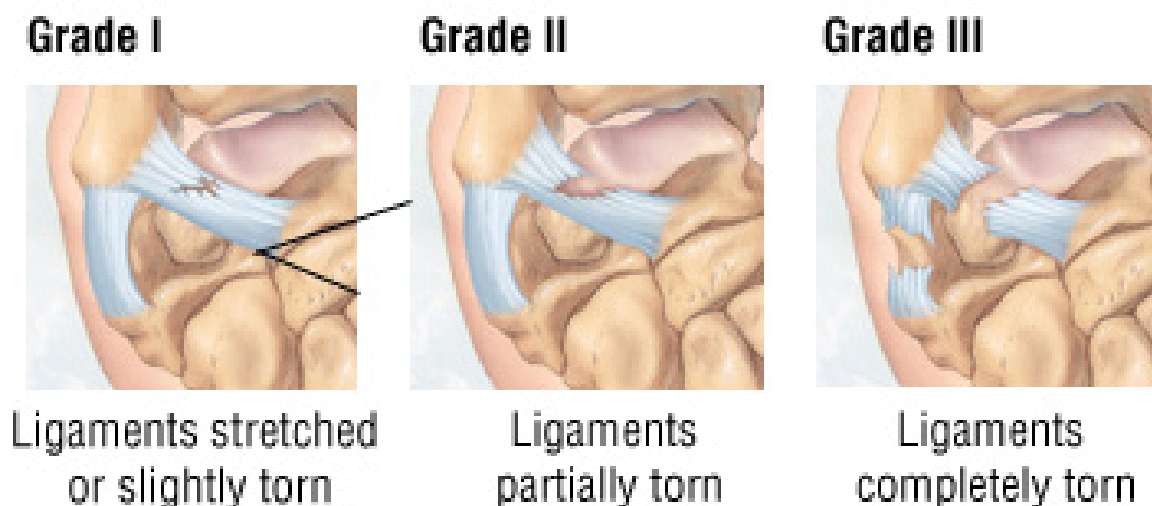

Wrist Bone Fracture: if you fell on an outstretched hand with your hand striking hard floor that almost instantly manifested pain and tenderness at the wrist and base of the thumb, it could be a wrist bone fracture and this warrants medical attention within 48 hours.

A brace or a cast must be worn until fully healed.

Wrist Ligament Tear: this is a result of impaction or twisting of the wrist. One is to experience pain whenever he/she tries to grip.

Physical evaluation is needed in order to recommend the proper brace and/or cast and prevent long-term problems.

Stress Fracture: this is the most common result of repetitive movement that overcomes the strength of the bones, and thus, leads to small stress fractures.

Physical evaluation, diagnostic tests, and brace/casts will be recommended for mild to moderate cases.

Carpal Tunnel Syndrome: is a condition that causes numbness, tingling and other symptoms in the hand and arm. Carpal tunnel syndrome is caused by a compressed nerve in the carpal tunnel, a narrow passageway on the palm side of your wrist. There also are some medical conditions that make carpal tunnel syndrome more possible like hypothyroidism, obesity, pregnancy, arthritis, diabetes, and wrist trauma.

Treatment usually consists of resting the affected hand and wearing a splint or a brace to limit mobility if at all possible.



As it has been seen in most wrist injuries, the best way to help solve them is through a wrist splints. These, are rigid or soft medical devices that wrap around the wrist to help prevent and/or treat injuries. A wrist splint may be used to support, protect, compress or immobilize the wrist joint, bones and ligaments during injury rehabilitation, and to ease pain and stiffness from chronic conditions such as carpal tunnel syndrome, arthritis, tendinitis, osteoarthritis and gout, and from long-term repetitive stress.

Wrist splints are often recommended for treatment of stable fractures of the carpal joints and the distal radius, and also for sprains and strains of the wrist. Most wrist braces and splints allow hand and finger function, even when the wrist is immobilized.

2.3. MATERIALS

Regarding to the materials of which an orthosis can be made there is a huge variety, from traditional plaster casts to the material with used the three-dimensional (3D) printing technique, also known as additive manufacturing (AM), whose use is growing explosively, the reasons of this, will be studied later; since has being said, the orthosis can be constructed of varius materials, with each other, metal, plastic, neoprene, leather, synthetic fabrics, or any combination, though the plastic materials, such as thermosetting and thermoplastics, are the materials most commonly used in the orthotic industry.



Metals can be used for joint components, metal uprights, sprints, and bearings, the most used are stainless steel and aluminum alloys, are adjustable, but they are heavy and not cosmetically pleasing.

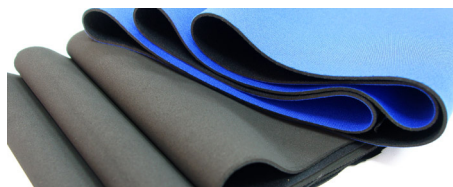

It also mentioned materials like neoprene, silicone or latex, since exhibit good chemical stability and maintain flexibility over a wide temperature range.

Thermosetting materials can be molded into permanent shape after heating. They do not return to their original consistency even after being reheated. As for the thermoplastics, it can be diferenciated two types, Low-temperature thermoplastics and High-temperature thermoplastics. The first can be softened in hot water and placed directly on the skin and are most appropriate for upper limb fractures or injuries, and the high temperature thermoplastic splints are made from a cast and require higher temperatures and a longer curing time to harden. These splints are better suited for lower limb or back injuries that generally require a longer healing period.



2.4. MANUFACTURING

The traditional orthosis process is time consuming, skill dependent and does not always guarantee a satisfactory orthosis. Furthermore, meet the total needs of the patient is often a problem, sparking the need to improve the process and subsequently the outcome. To overcome this, Additive manufacturing (AM), also commonly known as 3D printing, rapid prototyping or solid freeform manufacture, where objects are constructed via a series of sub-millimetre layers, may present the opportunity to overcome these limitations, and allow novel device in terms of fit and functionality.

Most orthosis are fabricated using Low-temperature thermoplastics, which manufacturing method is the following, the clinician places the patient's hand in a neutral position on a sheet of paper and then draws around the patient's hand, wrist and forearm and marks any anatomical landmarks that may be important to the clinician during the orthosis process. This creates the overall shape of the orthosis and a custom pattern for the patient. The thermoplastic is then heated in a water bath and the pattern is cut out. The clinician moulds the thermoplastic to the patient's forearm and or wrist. The clinician has a very limited time in which to make adjustments to the orthosis. Smaller sections of the orthosis can be reheated for local reshaping. Overall, this process is extremely linear; if the clinician needs to make any major changes to the design usually the simplest and most efficient method is to start the whole process again.

The main aim of using Additive Manufacturing (AM) to produce orthosis is to get higher levels of compliance amongst patients who are required to wear a wrist orthosis. For it, it is necessary to study the disadvantages presented by the traditional orthosis, such as:

- Difficulties keeping orthosis clean and dry.
- Induced perspiration, subsequently leading to odour issues.
- Poor aesthetics.
- Weight implications.
- Discomfort, poorly fitted orthosis can cause pressure points and friction.
- Limited function and compromised performance during everyday tasks.
- Fasteners which may be difficult to fix, adjust, remove and replace.
- Difficulty putting on and taking off the orthosis.

One of the purpose of the new orthosis in 3d printing is to be able to solve or improve the problems mentioned above . Orthosis can be made that are easier to clean. Splints can be made that have a pattern cut out leading to a greater aesthetic value and a lighter and more breathable orthosis. Using a scan of the patient's hand, a orthosis can be fabricated that fits perfectly.

There are many ways that AM can be used to improve the quality of life for someone who needs to wear a orthosis, some of the types that exist are the following:

Selective laser sintering (SLS): is an additive manufacturing technique that uses a laser as the power source to sinter powdered material (typically nylon/polyamide), aiming the laser automatically at points in space defined by a 3D model, binding the material together to create a solid structure.

ADVANTAGES

- Parts possess high strength and stiffness.
- Good chemical resistance.
- Various finishing possibilities.
- Bio compatible according to EN ISO 10993-1 and USP/level VI/121 °C.
- Fastest additive manufacturing process for printing functional, durable, prototypes or end user parts.

DISADVANTAGES

- SLS printed parts have surface porosity.

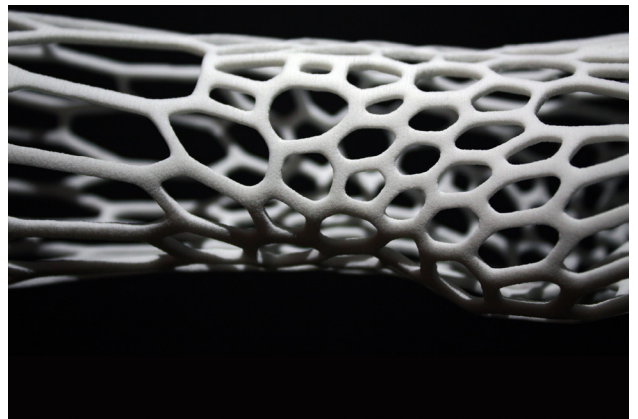

Fused deposition modeling (FDM): is an additive manufacturing (AM) technology commonly used for modeling, prototyping, and production applications. FDM works on an “additive” principle by laying down material in layers; a plastic filament or metal wire is unwound from a coil and supplies material to produce a part.

Myriad materials are available, such as Acrylonitrile Butadiene Styrene (ABS), Polylactic acid (PLA), Polycarbonate (PC), Polyamide (PA), Polystyrene (PS), lignin, rubber, among many others, with different trade-offs between strength and temperature properties.

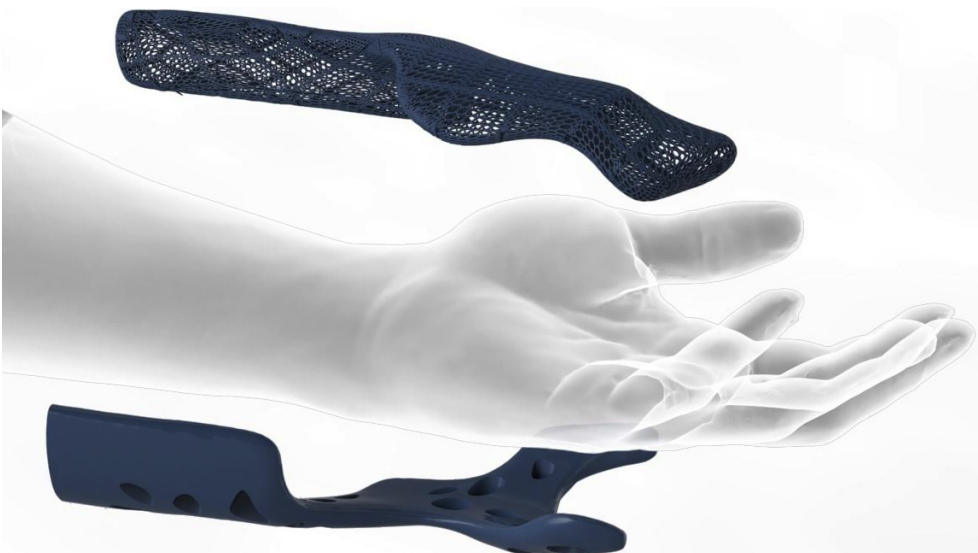

Stereolithography (SLA): is a form of 3D printing technology used for creating models, prototypes, patterns, and production parts in a layer by layer fashion using photopolymerization, a process by which light causes chains of molecules to link, forming polymers. Medical modeling - prosthetists and technologists also use models as an aid to the design and manufacture of custom-fitting implants.

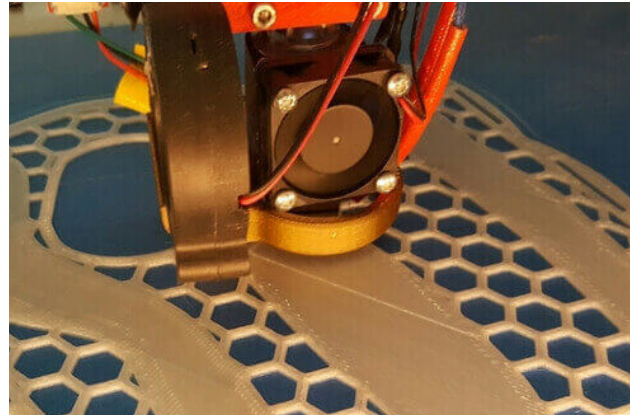
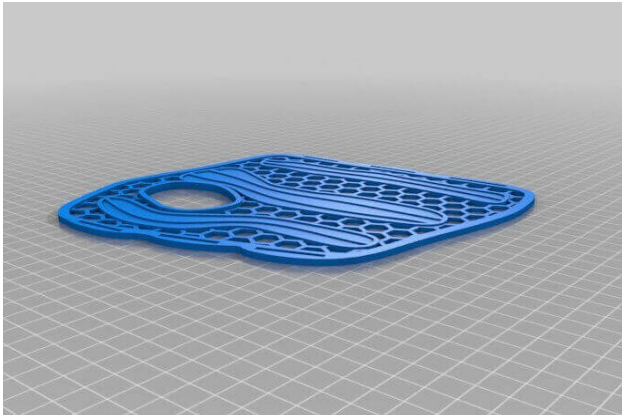

Material Jetting (MJ): is an additive manufacturing process that operates in a similar fashion to 2D printers. In material jetting, a printhead dispenses droplets of a photosensitive material that solidifies under ultraviolet (UV) light, building a part layer-by-layer. The materials used in MJ are thermoset photopolymers (acrylics) that come in a liquid form.

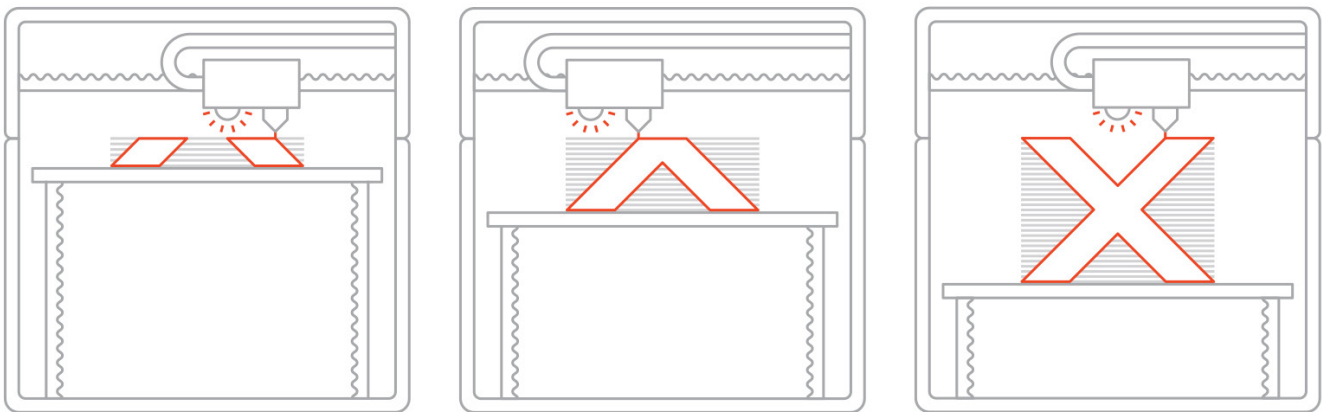

Previously, four different techniques have been studied about additive manufacturing in detail, but they are not the only ones that exist in this area. Next, can be seen a scheme with the different techniques of 3D printing:

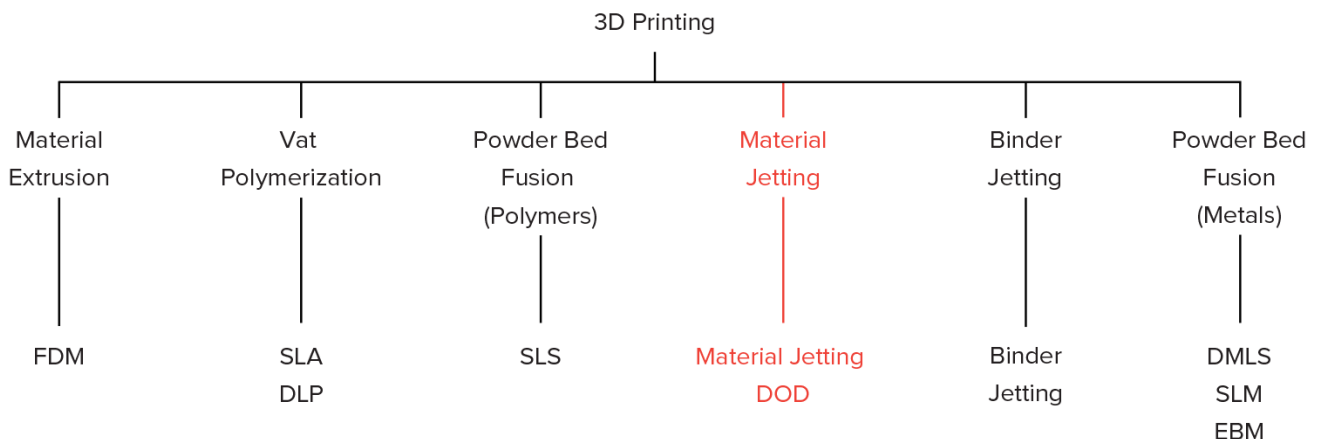

2.5. CREATION PROCESS

As has already been explained, 3D printing has become a reality in the world of health. This advance in technology allows to create solutions adapted and customised for patients. In order for this to be possible, we must look at the fabrication of orthoses produced both using traditional methods and 3D printed.

The process of creating an orthosis by additive manufacturing, begins with an evaluation of X-rays on the fractured person, and later a three-dimensional scan of the area is made using a 3D scanner. Once this has been done, the model of the orthosis is processed using CAD software, considering the proportions of the patient's limb. Finally, through the 3D printing technology, the custom structure is printed. After the creation process is complete, all that remains is for the specialist to place and adjust the orthosis on the patient, leaving an orthosis fully adapted for each patient.

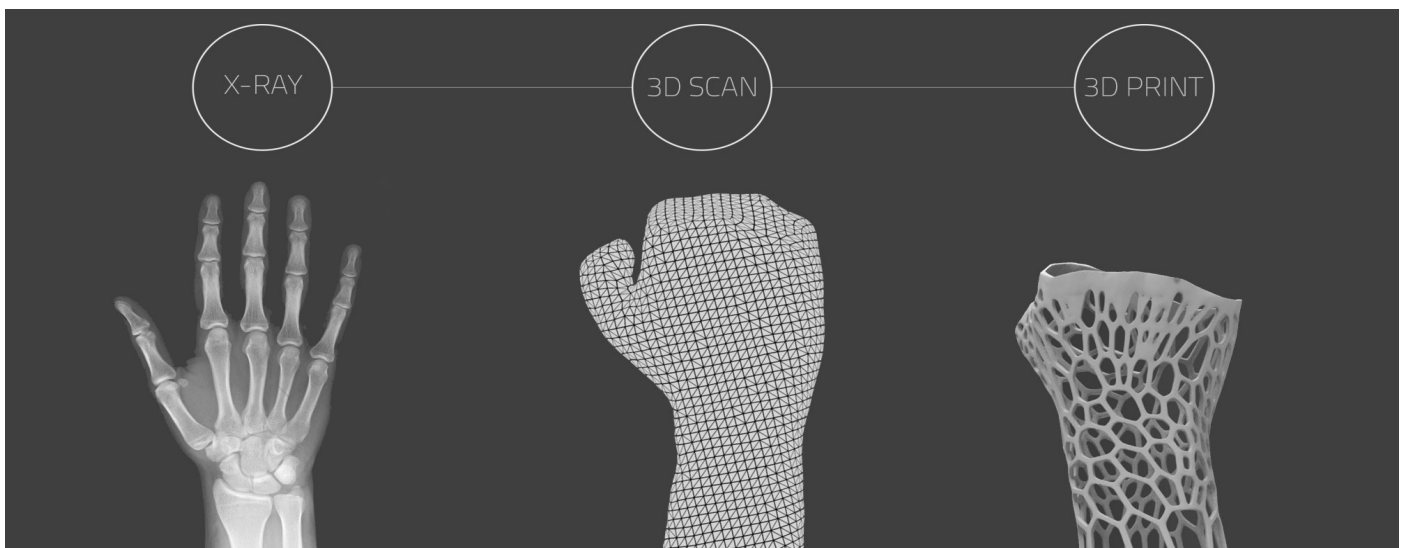

For the realization of a traditional orthosis, the first step must be done is taking a measurement of the body segment, once this, a negative impression is taken with a plaster of bandage. Upon hardening of the plaster, it is carefully cut or sectioned and removed, preserving the shape. Finally, the surface of the positive plaster model is smoothed by sanding.

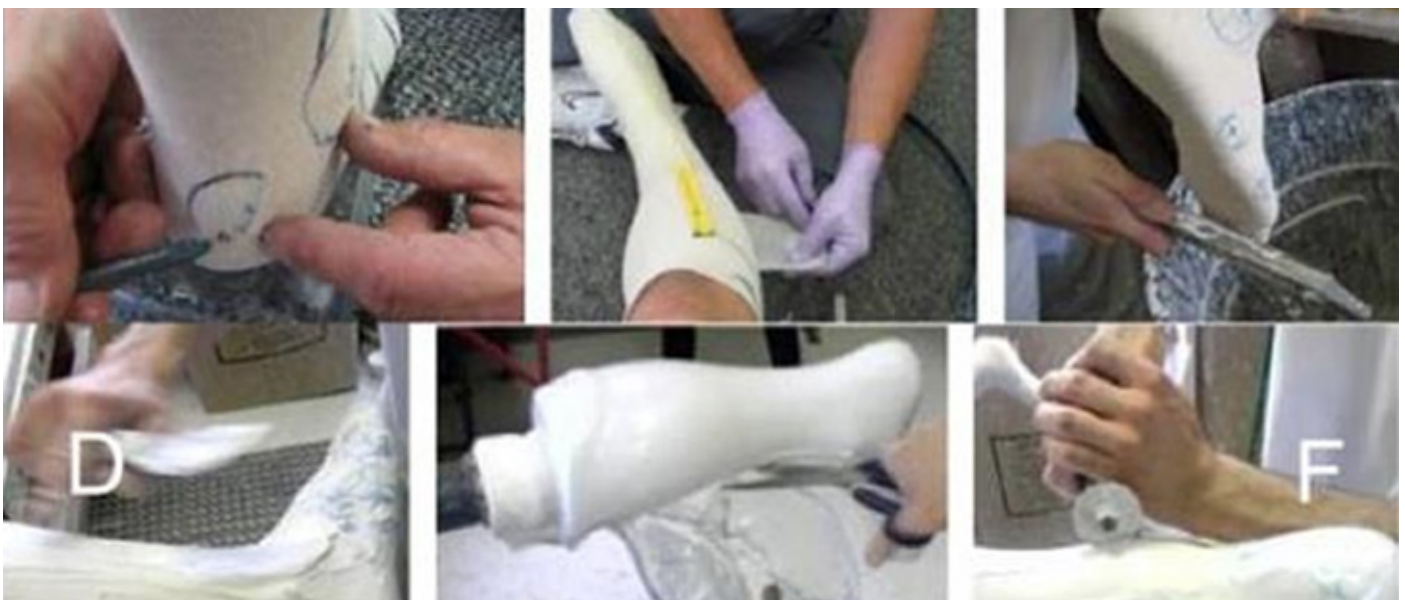

2.6. ADVANTAGES AND DISADVANTAGES OF 3D PRINTING

Could 3D printing reduce costs, increase orthotic efficacy and reinvent the industry with innovative designs?

The answer is yes, since 3D printing of custom orthoses has advantages over traditional orthotic manufacturing, this can produce custom shapes and geometries not possible through traditional fabrication techniques, devices can be made more quickly and are easier to modify and reproduce, and a permanent digital record is generated for all orthoses and any changes, enabling quick reprints and changes in the designs leading to some savings.

Furthermore, 3D printing can replace the stinking, uncomfortable and itchy casts used to heal broken bones. Made from scans, these orthoses are lightweight, custom-made and comfortable, and can be worn in the shower for optimal hygiene.

Another central feature is that 3D printing allows the designer to make custom fitted, durable 3D printed medical casts for individual's arm, and due to material properties the end products are slimmer, lighter, and environmentally friendly.

3D printing is a good method of use for third-world countries, given that it's a good method of being able to offer this type of medical service, something essential for everybody, As low-cost orthosis sockets are being developed for them.



As well as the good qualities it has, it also has some bad qualities and that's why this method is still under investigation and is still being developed. For 3D printing to be used on a greater scale in orthosis, development and manufacturing times and their associated costs need to be reduced.

After examining factors that influence the cost-benefit ratio and feasibility associated with new 3D printing equipment, it is apparent there are still several technical limitations to printing custom orthoses. These limitations may be overcome, however, and the associated costs reduced, as the technology becomes more common and as future innovations produce larger and faster 3D printers.

2.7. MASS PRODUCTION OR PERSONALIZED ORTHOSIS

Regarding the development of the orthosis, a distinction must be made between an orthosis made specifically to meet the patient's needs, or a prefabricated orthosis. The main difference is that prefabricated orthosis are standardized, made in production chains; while personalized orthoses are uniquely designed for each limb and subject.

Amongst the things which need to be taken into consideration is that the prefabricated orthosis are sold according to the size of the client. In the case of personalized ones, the specificity is much greater, they are exclusive and adapt to the morphological and functional characteristics of the patient's limb; they require a previous study and the creation of a mould of the limb or live adaptation techniques.

Prefabricated orthosis are less expensive and are readily available as commercial products. However, an orthosis which is personalised for its purpose, the study and previous molds, and its durability, is more expensive than standard ones. Some are manufactured in bulk and others are made to measure, in addition to the guarantee of using materials suitable for both cases, which have been previously tested and guaranteed to be totally hypo-allergenic materials.

According to the specialist Kevin A. Kirby "Personalized orthosis have a longer shelf life because the materials with which they work (5 -15 years) against to the prefabricated (3 - 9 months). Due to the same reason, personalized orthosis suffer less damage and changes.

As seen throughout this study, traditionally, personalized orthosis are manufactured using a plaster casting technique, so the manufacturing process is more expensive compared to prefabricated orthosis. But nowadays, thanks to additive manufacturing, much of this work can be removed and it is possible to create a personalized orthosis in a short time, which is ideal for mass customization.

Taking into account all the data had previously been stated, it can be concluded that the prefabricated supports are produced faster, are cheaper and do not require a mold in the fabrication process, compared to the advantage of the custom ones, that their creation is in accordance with the specific requirements of each patient. In addition, when produced from a three-dimensional mold, the adaptation is practically perfect, which works better than a standard form that "adapts to all."

PREFABRICATED ORTHOSIS



Standard

PERSONALIZED ORTHOSIS

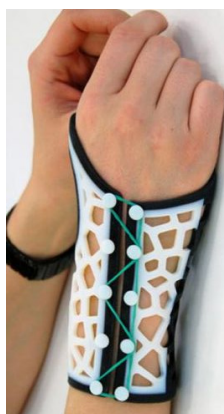

3d printed

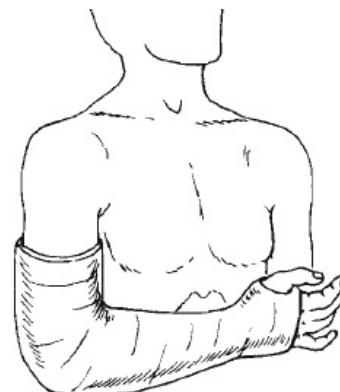

Traditional plaster

STATE OF ART

3

A prerequisite for this section is a good knowledge of the scientific literature in this field, as by reading literature related to the topic, can be learned the basic principles of orthosis and, therefore, it will be helpful to understand and analyze the problem.

This section shows different approaches to a solution, these are carried out by other designers and that are possible to see in the market nowadays. Thanks to this detailed study it has been possible to analyse the different characteristics which an orthosis device should have according to stand out amongst other competitors in the same market, as well as should fulfill a number of requirements in order to meet the user's needs.

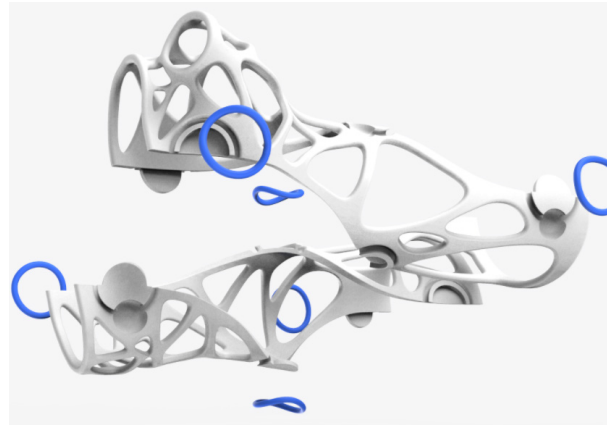

XKELET

COMPANY:

Xkelet Easy Life SL.

MANUFACTURING:

3D printed.

FUNCTION:

immobilizes injured bones, recovery cycle of the limbs.

MATERIAL:

PLC

ECOLOGICAL COMPATIBILITY:

recyclable material, biocompatible.

IMPERMEABILITY:

completely waterproof.

WEIGHT:

lightweight, less than 100 grams.

ERGONOMICS:

tailor-made to the contour of the immobilized limb.

OTHER FEATURES:

the helical cut that divides the assembly into two halves, determines a single position of coupling between them and guarantee the stability in its position, for the use of the closure.

The design of the openings throughout the immobilization are based on organic forms, with rounded ends to assist the evacuation of water and moisture and provide the whole of a great comfort in contact with the skin.

REFERENCE:

<https://www.3ders.org/articles/20160707-xkelet-wins-red-dot-award-for-custom-fitting-3d-printed-orthosis-that-optimizes-hygiene-and-comfort.html> <https://www.xkelet.com/>

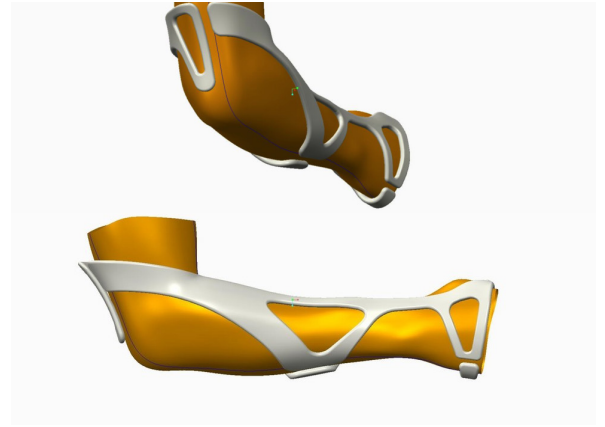

SCOTT SUMMIT

COMPANY:

Summit ID.

MANUFACTURING:

3D Systems Selective, Laser Sintering.

FUNCTION:

stabilize any motion of the hand with respect to the forearm, with a 3D cast that rest on just three parts of his arm.

MATERIAL:

polyamide, tumbled.

ECOLOGICAL COMPATIBILITY:

recyclable material.

IMPERMEABILITY:

completely waterproof.

WEIGHT:

just five millimeters thick, it's a fraction of a traditional cast's heft.

ERGONOMICS:

each brace have to be tailored to individual.

OTHER FEATURES:

allows the wearer to conduct daily tasks like playing the guitar and slicing veggies.

REFERENCE:

<http://www.summitid.com/#/post-operative/>

<https://www.fastcodesign.com/3049149/healing-injuries-could-be-better-thanks-to-this-3-d-printed-cast>



ANDIAMO

COMPANY:

Andiamo.

MANUFACTURING:

3D printed.

FUNCTION:

post-operative rehabilitation, metacarpal fractures, minor forearm fractures, post-cast removal and cast substitute for long term use.

MATERIAL:

polymer lighter, stronger materials.

ECOLOGICAL COMPATIBILITY:

environmentally friendly.

IMPERMEABILITY:

completely waterproof.

WEIGHT:

Andiamo orthosis are up to 65% lighter than traditional ones.

ERGONOMICS:

custom-made for each patient.

OTHER FEATURES:

orthosis that provide a perfect fit.

orthosis that are effective.

REFERENCE:

<https://andiamo.io/> <http://imprimalia3d.com/noticias/2017/03/26/008911/ni-que-inspir-una-empresa-rtesis-impresas-3d>

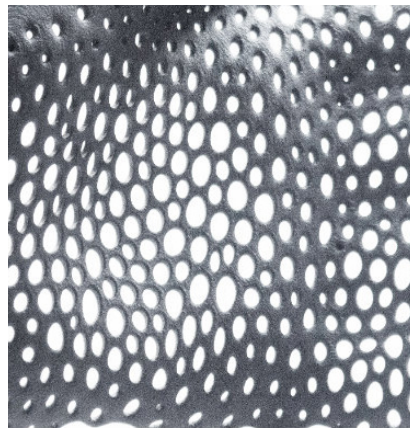

GENERATIVE ORTHESES

COMPANY:

MHOX and CRP.

MANUFACTURING:

a process called laser sintering.

FUNCTION:

is an orthosis that adapts to the physiognomy and the needs of each user, that is, an external support device "which is applied to the body to modify the functional or structural aspects of the skeletal neuromuscular system".

MATERIAL:

using CRP Group's polyimide material (Windform GT).

ECOLOGICAL COMPATIBILITY:

recyclable.

IMPERMEABILITY:

its reinforced polyamide-based materials are waterproof.

WEIGHT:

lvery light.

ERGONOMICS:

the flexibility can be adjusted depending on application.

OTHER FEATURES:

honeycomb-style ventilation, impressive flexibility and recently passed a skin irritation analysis.

REFERENCE:

https://mashable.com/2015/04/28/3d-printed-orthotics/?utm_cid=mash-com-pin-link#BLdhB8.XVZq2

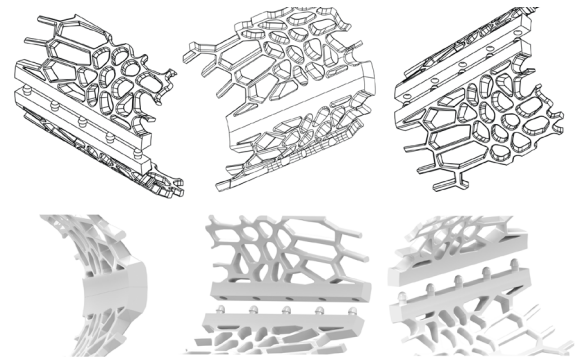

CORTEX

COMPANY:

Evill Design.

MANUFACTURING:

3D printed.

FUNCTION:

fracture support, immobilizes injured bones for the best and the fastest healing. The Cortex exoskeletal cast provides a highly technical and trauma zone localized support system that is fully ventilated.

MATERIAL:

ABS.

ECOLOGICAL COMPATIBILITY:

recyclable.

IMPERMEABILITY:

completely waterproof.

WEIGHT:

super light, thin.

ERGONOMICS:

define the exact dimension of the limb of each patient.

OTHER FEATURES:

innovative product for its design, shape, manufacture and materials used, also it has a duration of 5 years.

REFERENCE:

<http://www.evilldesign.com/cortex>



NOVACAST

COMPANY:

MediPrint.

MANUFACTURING:

3D printed.

FUNCTION:

hold, align or correct deformities and improve the function of the locomotor systems.

MATERIAL:

polymer.

ECOLOGICAL COMPATIBILITY:

recyclable.

IMPERMEABILITY:

because of its materials it can get wet without problems, either when bathing or swimming.

WEIGHT:

ten times lighter than traditional plaster casts.

ERGONOMICS:

the structure is getting to be custom-made for the patient by means of a process of scanning, modeling and 3D printing.

OTHER FEATURES:

due to its design it allows the area to be properly oxygenated and prevents the generation of bad odors. In addition, it allows the doctor to review the evolution of the fracture.

It is placed and removed easily thanks to its clip system.

REFERENCE:

<https://mediprint3d.com.mx/servicios/novacast-de-mediprint/>



OSTEOID

COMPANY:

Deniz Karasahin.

MANUFACTURING:

3D printed.

FUNCTION:

medical cast, attachable bone stimulator.

MATERIAL:

made of a lightweight plastic.

ECOLOGICAL COMPATIBILITY:

environmentally friendly.

IMPERMEABILITY:

impervious to water.

WEIGHT:

slimmer, lighter.

ERGONOMICS:

the Osteoid is custom fitted.

OTHER FEATURES:

Osteoid medical cast can also be combined with its complimentary, low intensity pulsed ultrasound (LIPUS) bone stimulator system speeding the healing process. The LIPUS pulse generator has an on /off button at its side.

REFERENCE:

<https://competition.adesignaward.com/design.php?ID=34151> <http://www.3dprinterworld.com/article/3d-printed-osteoid-from-deniz-karasahin>

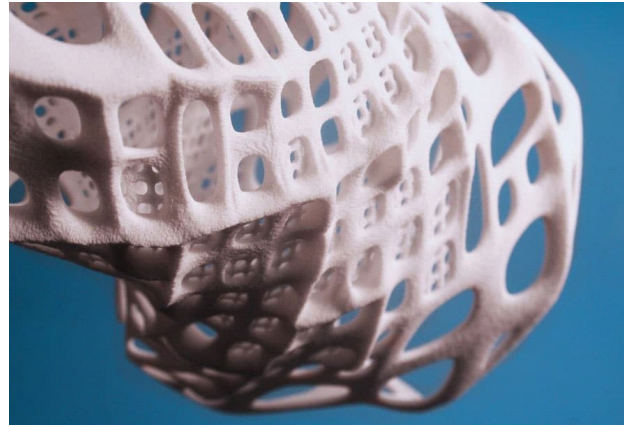

SPLINT PLUS

COMPANY:

UCLA's school of Architecture & Urban Design.

MANUFACTURING:

selective laser sintering or SLS.

FUNCTION:

immobilizes injured bones.

MATERIAL:

Poliamida/Nylon

ECOLOGICAL COMPATIBILITY:

environmentally friendly.

IMPERMEABILITY:

completely waterproof.

WEIGHT:

these 3D printed wrist splints are very strong, lightweight.

ERGONOMICS:

these wrist splints are intricate, detailed and customized for a perfect fit and optimal support.

OTHER FEATURES:

is a prototype exoskeleton, which was designed around the actual structure of the bone. They were inspired because of the need for them in underdeveloped regions around the world.

REFERENCE:

<http://www.bitrebels.com/technology/customized-3d-printed-wrist-splint/>



ANAIS

COMPANY:

Summit ID.

MANUFACTURING:

SLA 3D print, Selective Laser Sintering.

FUNCTION:

3D printed fracture cast for her radius bone.

MATERIAL:

polyamide, tumbled.

ECOLOGICAL COMPATIBILITY:

recyclable material.

IMPERMEABILITY:

completely waterproof.

WEIGHT:

less than the weight of traditional orthosis.

ERGONOMICS:

custom-made for the patient.

OTHER FEATURES:

It made in SLA 3D print, though not by itself strong or appropriate for skin contact, was created and then plated with a copper/nickel blend, leaving it cool to the touch and easy to clean.

REFERENCE:

<http://www.summitid.com/#/anais/>



EXO

COMPANY:

Gintare Cer.

MANUFACTURING:

3D printed.

FUNCTION:

allows a more comfortable healing experience.

MATERIAL:

polymer.

ECOLOGICAL COMPATIBILITY:

the EXO cast is then shredded, and its recycled material can be used for making new casts.

IMPERMEABILITY:

waterproof.

WEIGHT:

very light, thus improving the comfort.

ERGONOMICS:

cast is rapid-prototyped, it fits every patient perfectly.

OTHER FEATURES:

Its open and dismountable structure allows starting physiotherapy immediately, which significantly shortens healing time, and prevents post-traumatic complications, such as muscle atrophy or joint contracture.

REFERENCE:

<http://cargocollective.com/gintarecer/Exo>



YOUNEXT

COMPANY:

Podoactiva.

MANUFACTURING:

3D printed.

FUNCTION:

replaces a cast in a girl with a wrist fracture.

MATERIAL:

the structure is made of polymer and this one has practical hook-and-loop closures.

ECOLOGICAL COMPATIBILITY:

environmentally friendly.

IMPERMEABILITY:

waterproof (you can bathe with the orthosis).

WEIGHT:

lighter weight than the traditional orthosis.

ERGONOMICS:

custom-made for the patient, also velcro strapping helps provide an anatomically correct fit.

OTHER FEATURES:

breathable, you can see the skin, you can apply electro stimulation without removing the orthosis, can be put on and removed if necessary (for the doctor's review, cleaning, etc).

REFERENCE:

<https://www.podoactiva.com/es/blog/innovacion/sustituimos-por-primera-vez-en-una-nina-su-esca-yola-por-una-ferula-younext>

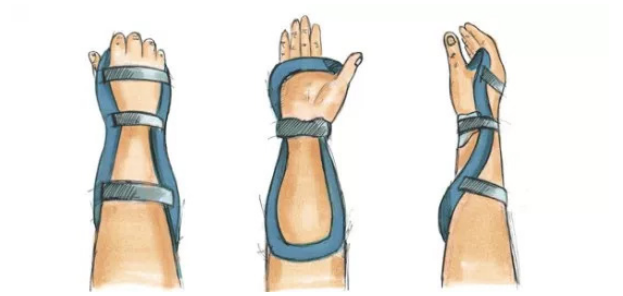
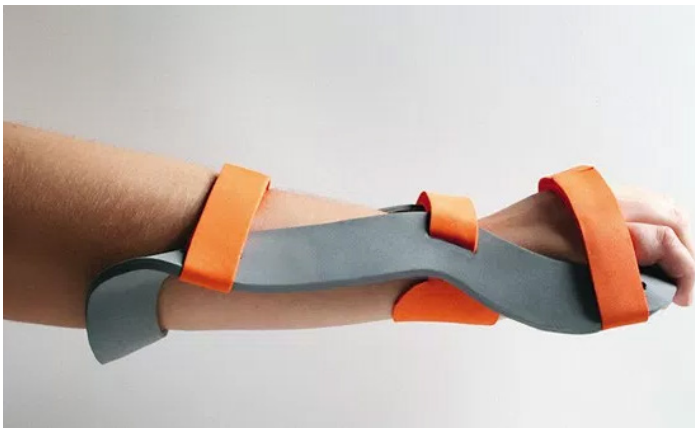

TENSION

COMPANY:

Marina Scheinberg.

MANUFACTURING:

easy to produce on a large scale with only foams.

FUNCTION:

cases of immobilization due to induced injury, as well as recovery after the operation.

MATERIAL:

common soft foam.

ECOLOGICAL COMPATIBILITY:

recyclable and reusable.

IMPERMEABILITY:

it is not waterproof.

WEIGHT:

light.

ERGONOMICS:

custom-fitting orthosis.

OTHER FEATURES:

more flexible, frictionless, comfortable system and an effective healing solution.

REFERENCE:

<http://www.dsgnr.cl/2013/08/brazo-ortopedico-tension-marina-scheinberg/>



STABILITYPRO™

COMPANY:

Stability Pro

MANUFACTURING:

polymerization.

FUNCTION:

arthritis, tendonitis, wrist sprains and other type of wrist injuries. The stabilizing splint helps with providing a rigid structure to keep the wrist from excessive movement.

MATERIAL:

neoprene, which is breathable, moisture releasing mesh material is durable, soft, latex-free, and will not chafe.

ECOLOGICAL COMPATIBILITY:

no conclusive information found.

IMPERMEABILITY:

waterproof.

WEIGHT:

light weight and comfortable for all-day wear and night use.

ERGONOMICS:

velcro strapping helps provide an anatomically correct fit, ensuring proper support. Different sizes.

REFERENCE:

https://stabilitypro.com/products/wrist-support-splint-brace-stabilizer-orthotic-neoprene-forearm-protector-guard-immobilizer-adjustable-velcro-strap-carpal-tunnel-pain-tendonitis-arthritis-sprain-ulnar-sports-typing?utm_campaign=Pinterest%20Buy%20Button&utm_medium=Social&utm_source=Pinterest&utm_content=pinterest-buy-button-065e1734b-0ed2-4b3a-a5bb-d141c41867f8

Size	Length	Width
S	8"	8"
M	8.5"	8.25"
L	9"	8.75"



CORFLEX WRIST HAND

COMPANY:

Advent Medical Systems

MANUFACTURING:

injection molding, extrusion and compression.

FUNCTION:

post-operative rehabilitation, metacarpal fractures, minor forearm fractures, post-cast removal and cast substitute for long term use.

MATERIAL:

rigid polyethylene laminated to soft closed cell foam lining.

ECOLOGICAL COMPATIBILITY:

recyclable.

IMPERMEABILITY:

waterproof.

WEIGHT:

light.

ERGONOMICS:

anatomically designed to conform to the natural shape of the wrist.

Sizing: measure wrist circumference, different sizes.

X-Small 5 - 6"	Small 6 - 7"	X-Large 9 - 10"
Medium 7 - 8"	Large 8 - 9"	

OTHER FEATURES:

Comfortable and secure immobilization.

REFERENCE:

<https://adventms.com/upper-extremity/162-corflex-wrist-hand-orthosis.html>



WRIST ORTHOSIS

COMPANY:

DonJoy

MANUFACTURING:

polymerization.

FUNCTION:

provides support and protection for injuries to the wrist and forearm. Used primarily for non-displaced fractures to the distal radius or distal ulna, and can be employed for acute injuries as well as for post-operative support.

MATERIAL:

neoprene, which is breathable, material is durable, soft, latex-free, and will not chafe.

ECOLOGICAL COMPATIBILITY:

no conclusive information found.

IMPERMEABILITY:

it is not waterproof.

WEIGHT:

lighter weight than the traditional orthosis and the 3D printed.

ERGONOMICS:

presents to closure which helps provide an anatomically correct fit, ensuring proper support.

OTHER FEATURES:

the closure consists of a circular rotating part, according to the side on which it rotates, provide an correct fit, according to each patient.

REFERENCE:

www.medicalexpo.es/prod/donjoy/product-96003-610563.html



QUERVAIN

COMPANY:

Quervain.

MANUFACTURING:

no conclusive information found.

FUNCTION:

limit unwanted movements of the wrist, post-operative rehabilitation, metacarpal fractures, minor forearm fractures, post-cast removal and cast substitute for long term use.

MATERIAL:

thermoplastic, it is covered with plastazote and the closing is done by means of two velcro tapes.

ECOLOGICAL COMPATIBILITY:

no conclusive information found.

IMPERMEABILITY:

no conclusive information found.

WEIGHT:

light and comfortable.

ERGONOMICS:

velcro strapping helps provide an anatomically correct fit, ensuring proper support. Different sizes.

REFERENCE:

<http://www.exclusivasiglesias.com/es/productos/p/381/f%C3%A9rula-de-quervain-ref-fp-d75-dr-cha-fp-i75-izq>

STATE OF ART CONCLUSION

Regarding the market research carried out previously, it can be seen that there are very few orthosis models created using a 3D printer given that it's a product that is still being developed in the medical field. Moreover, it is worth mentioning that the cost of the production process of custom orthosis is very high, something which over time and with technological advancements will decrease until finally it can be produced and sold at an affordable price for all users.

Another noteworthy point is that the majority of the examples found whilst carrying out market research provide a parametric design for orthosis. This is a great idea which allows disabled people to choose a range of options and makes them proud of their disabilities with an orthosis which matches their body and style. This leads us to the conclusion that the aesthetic factor is important at the design stage, given that an object is much more likely to sell if it is more visually pleasing.

On the other hand, we also have to take into account factors such as weight, the number of elements or the material, given that depending on the material chosen for production, it will comply with certain requirements or others. This last characteristic can be observed very clearly in my market research, since a big difference appears between the 3D printed orthosis (made with thermoplastics) and the traditional orthosis; thanks to the use of new materials, it has been possible to create orthosis which are weather resistant, a very important characteristic during the healing process of the user.

Therefore, we reach the conclusion that, in order for a product with these characteristics to achieve the best success, and therefore a main competitor in the market, it is necessary to know and improve the needs of users. In this case, prioritizing ease of use, comfort, lightweight, ergonomics, minimum number of elements, all at an affordable price for the client.

FUNCTIONAL REQUIREMENTS 4

This section shows the list of the different requirements and specifications that will be required of the product, needs that the designer must take into account when designing the orthosis, in order to ensure that the product meet the needs of the user. The table is divided in two columns, the left-hand column specifies the factors and the other column, the requirements to which it includes, which will be both aesthetic and functional.

Regarding the aesthetic value the product must have, the initial idea focuses on a simple shape for the orthosis, yet equally innovative, which will make it attractive for sale and therefore stand out in the market. Furthermore, a light structure is sought after and fairly exposed. Therefore, it is necessary to develop a good ventilation system. As for the issue of functionality, movement is key; an ortosis which can be easily assembled and unassembled requires little effort, and it can be adapted for all types of spaces and maneuvers. Additionally, a lightweight and resistant material with good durability will be used. All of the aforementioned requirements should be provided at a reasonable price which its users can afford, in order to be able to reach the wide target audience for this product.

LIST OF REQUIREMENTS					1/2	
3D PRINTED ORTHOSIS DESIGN					18/05/2018	
Nr.	Requirements	Value	Weight	Source	Responsible	Comments
1	Minimum elements		B	Appearance		
2	Simple shape		S			
3	Innovative		S			
4	Visually appealing		W			
5	Both sexes		S			
6	Ventilation holes		S			
8	For all sizes of people		B	Dimensions		
9	Adapts to all types of spaces and manoeuvres		B			
10	Possibility of adjustment		S			
11	Resistant		B	Materials		
12	Durable		B			
13	Recycable and reusable		B			
14	Waterproof		B			
15	Malleable		S			
16	Thermally insulative		B			
17	Elements eligible for the 3D printing		S			
18	Light		B	Weight		
19	Comfortable		B			
20	Slim		W			
21	Any age		W	Ergonomics		
22	Minimum physical effort		S			
23	Easy to manipulate		S			
24	Easy to use and remove		S			
25	Activity level (facilitate the occupational routine)		W			
26	Assemble and disassemble		S			
27	Easy accessibility in cleaning		S	Maintenance		
28	Ability spare parts, standard elements		B			
29	Weather resistant		B			
30	3D printing (SLS, FDM, material-jet)		S	Techniques		
31	Mass production		B			
32	Personalized		W			
33	Joints and assembly		S			

LIST OF REQUIREMENTS					2/2	
3D PRINTED ORTHOSIS DESIGN					18/05/2018	
Nr.	Requirements	Value	Weight	Source	Responsible	Comments
34	Without tools		S	Assembly		
35	Minimum elements		B			
36	Help elements		B			
37	Safety lock		B			
38	For all sizes of people		W	Durability		
39	Without sharp and dangerous elements		S	Safety		
40	Impact resistant		B			
41	Operating instructions		B			
42	Affordable		B	Price		
43	Low-cost		W			

- THE LEGEND OF THE CHART

Distinction or weighting of requirements:

- a) Basic ('Must be') (indicating 'B')
- b) Standard ('Needed') (indicating 'S')
- c) Wish ('Advance') (indicating 'W')

FIRST SKETCHES

5

The sketches made over the initial stage of the work are set out below, wherein it can be seen, in chronological order, the evolution of ideas, from the first drafts to the final product proposal, to later create in the CAD program. Thanks to this section ideas are developed, connecting with the product, and something very important, impracticable concepts are removed, to reach a final decision.

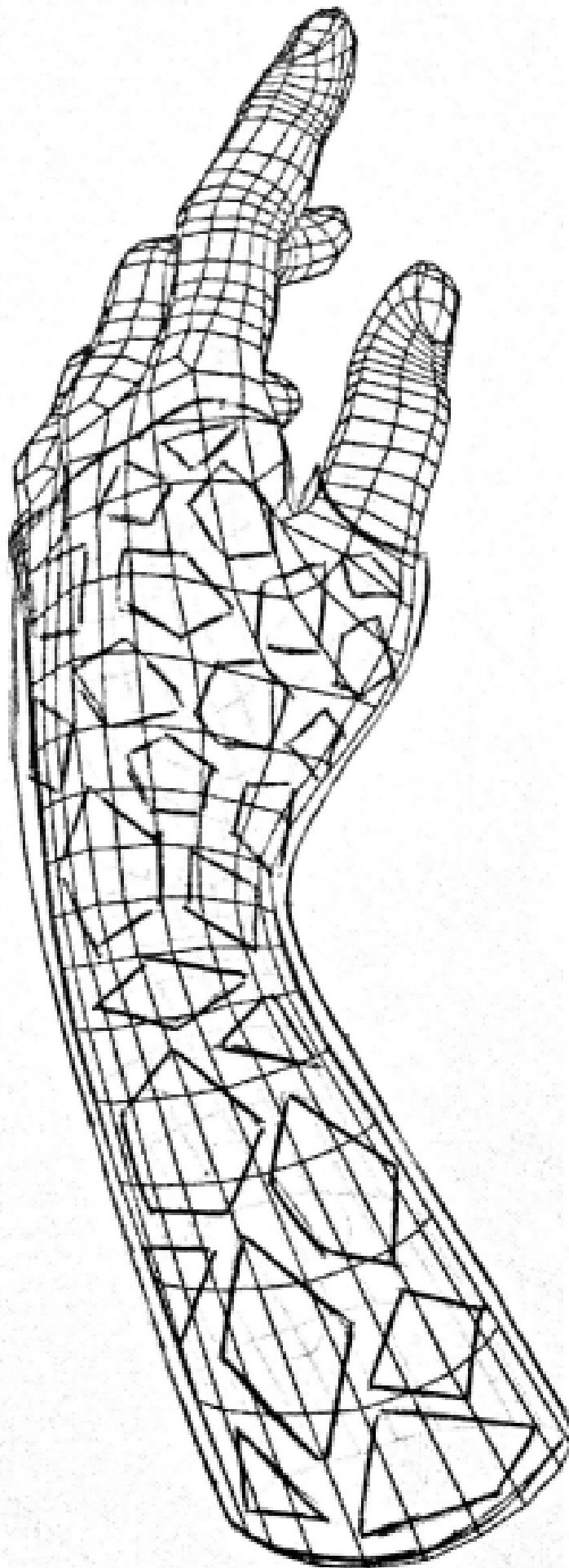

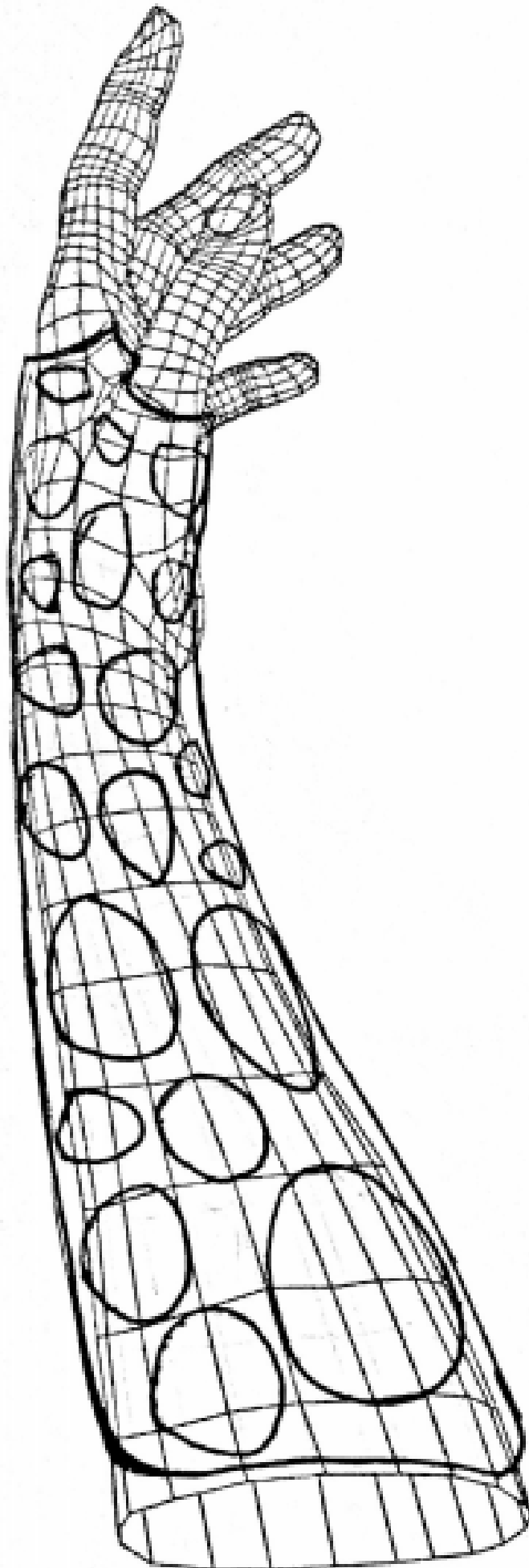

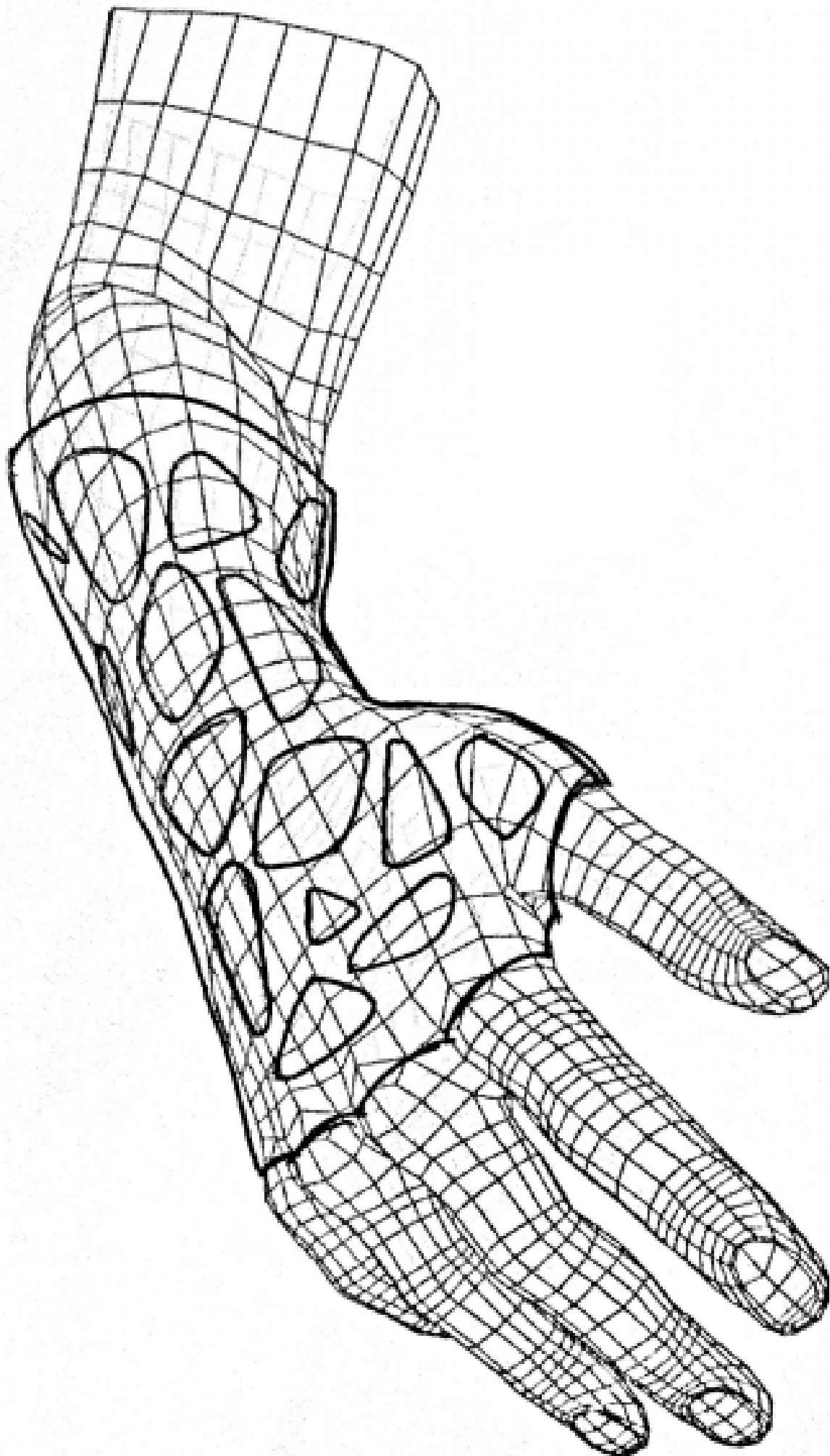

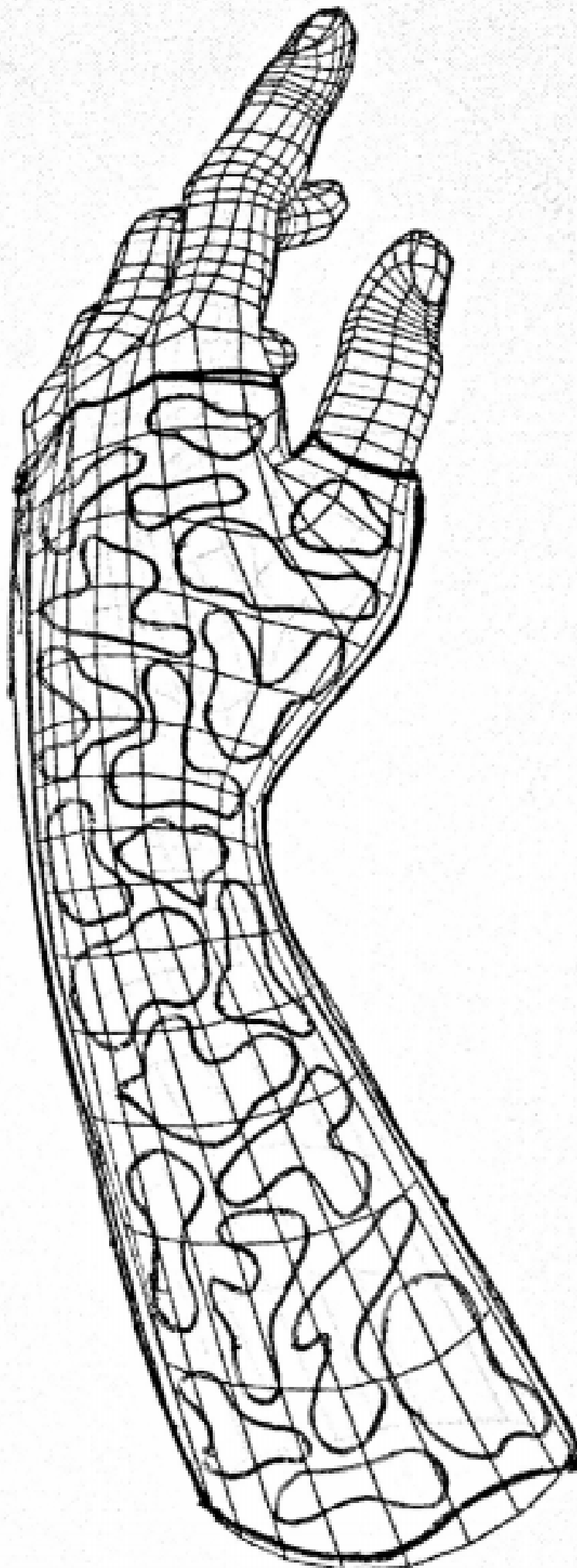

SKETCH N°5

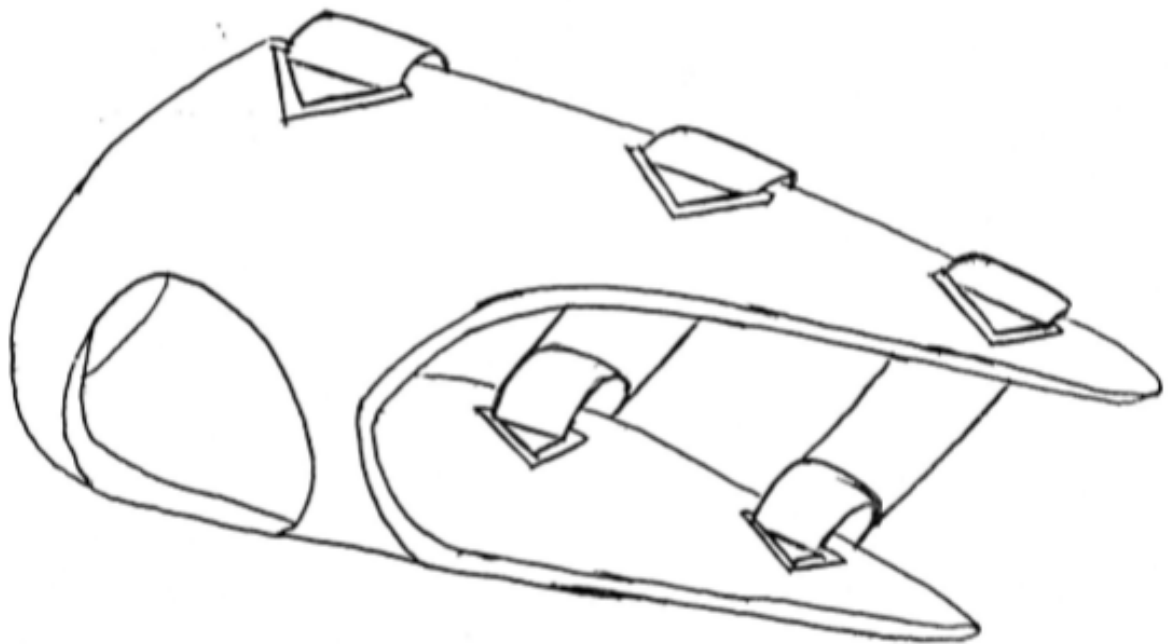
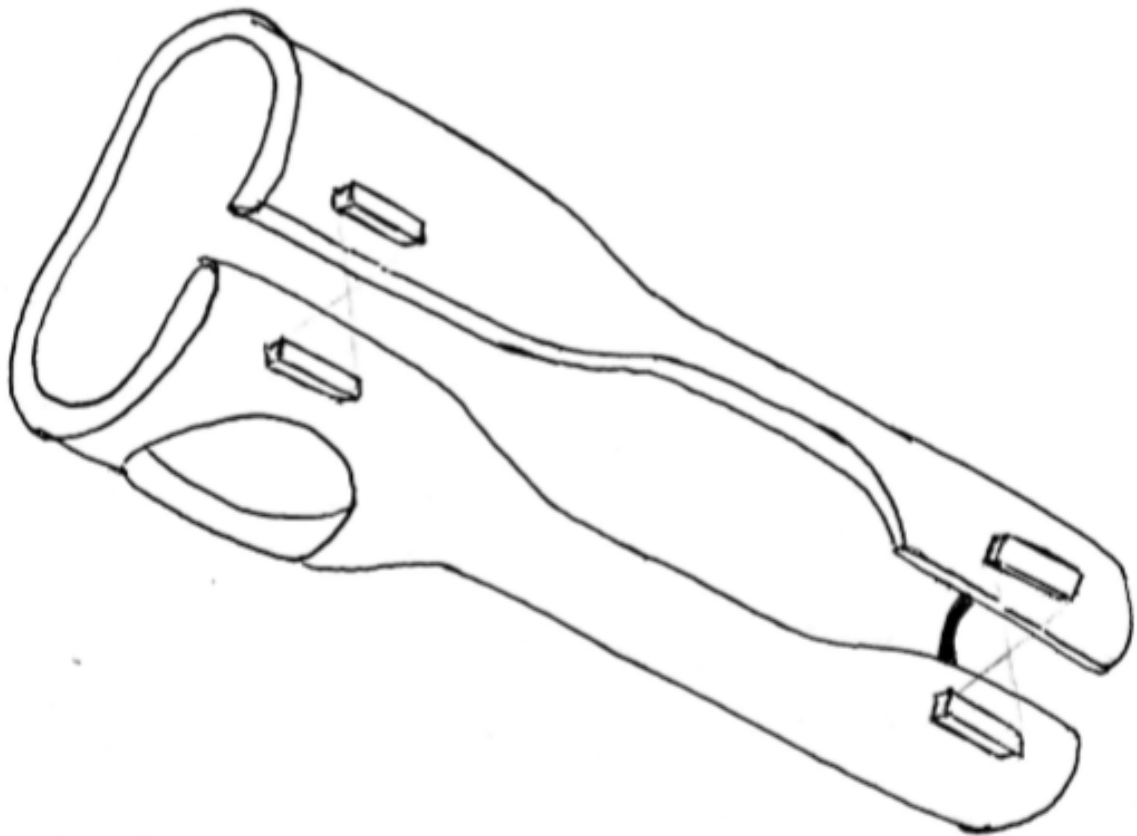

SKETCH N°6

SKETCH N°7

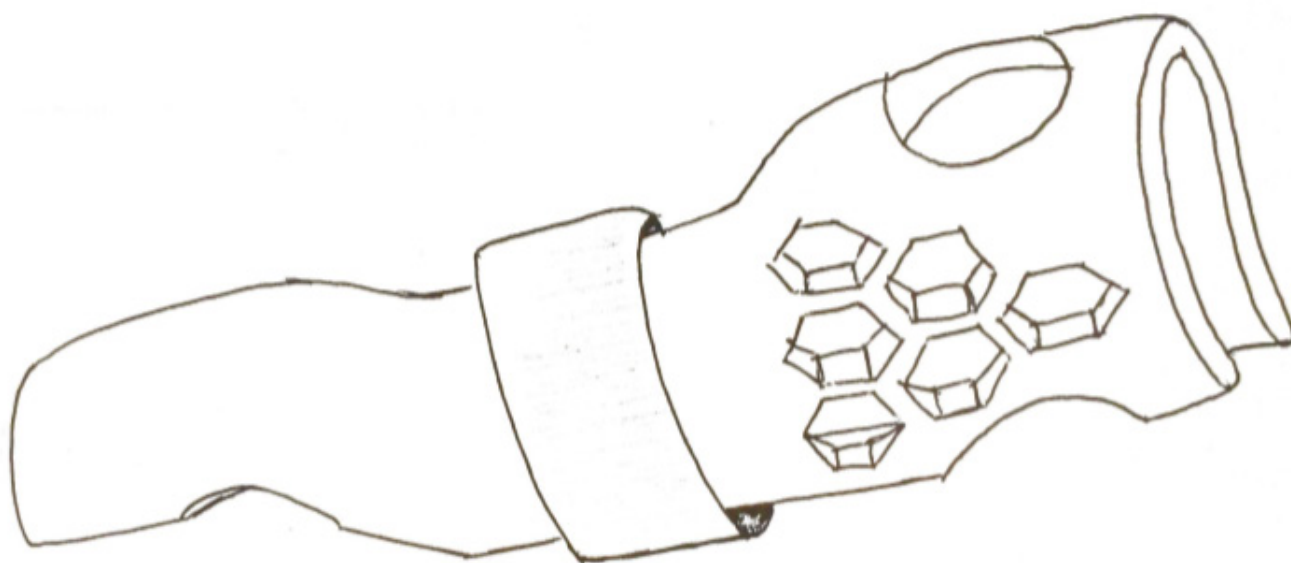
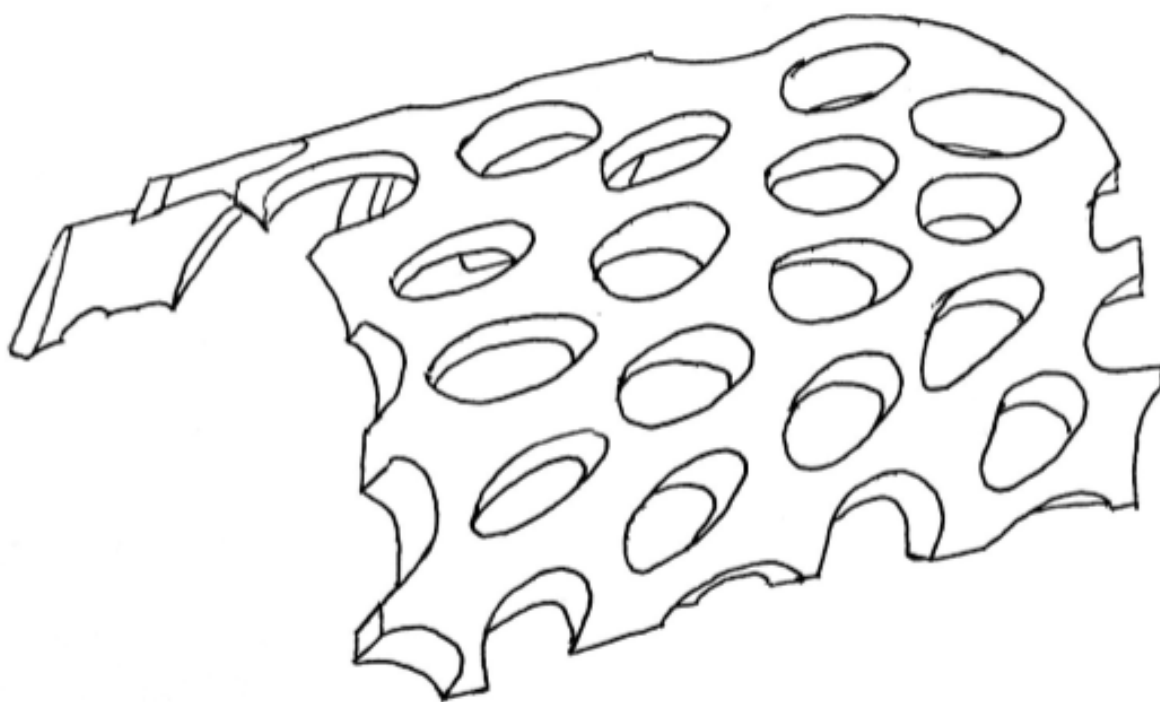

SKETCH N°8

SKETCH N°9

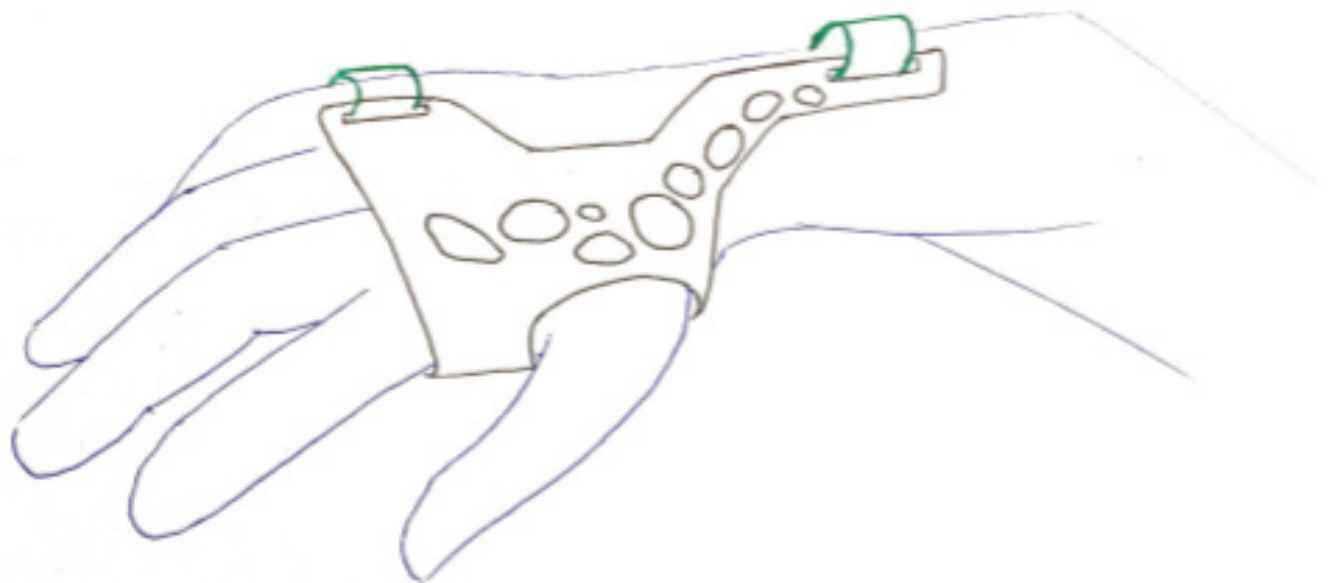
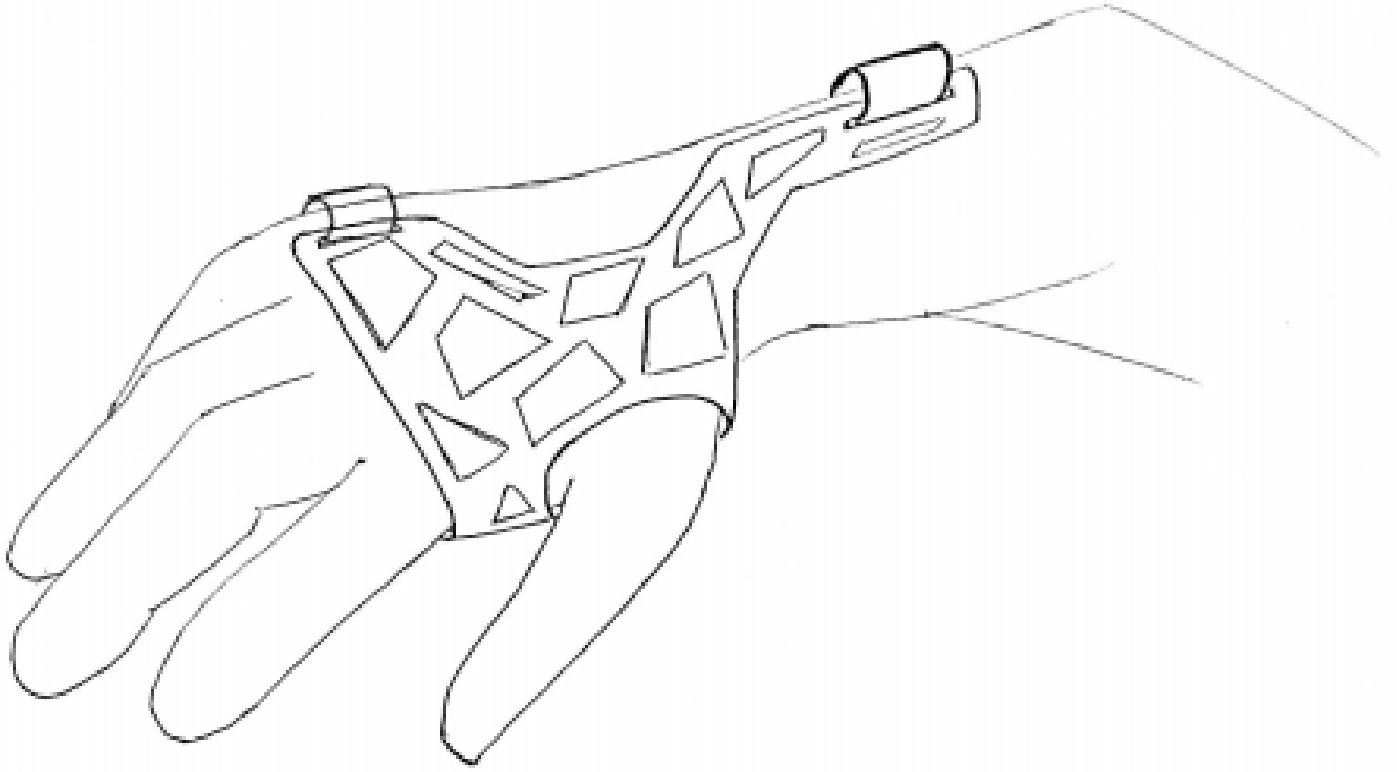

SKETCH N°10

SKETCH N°11

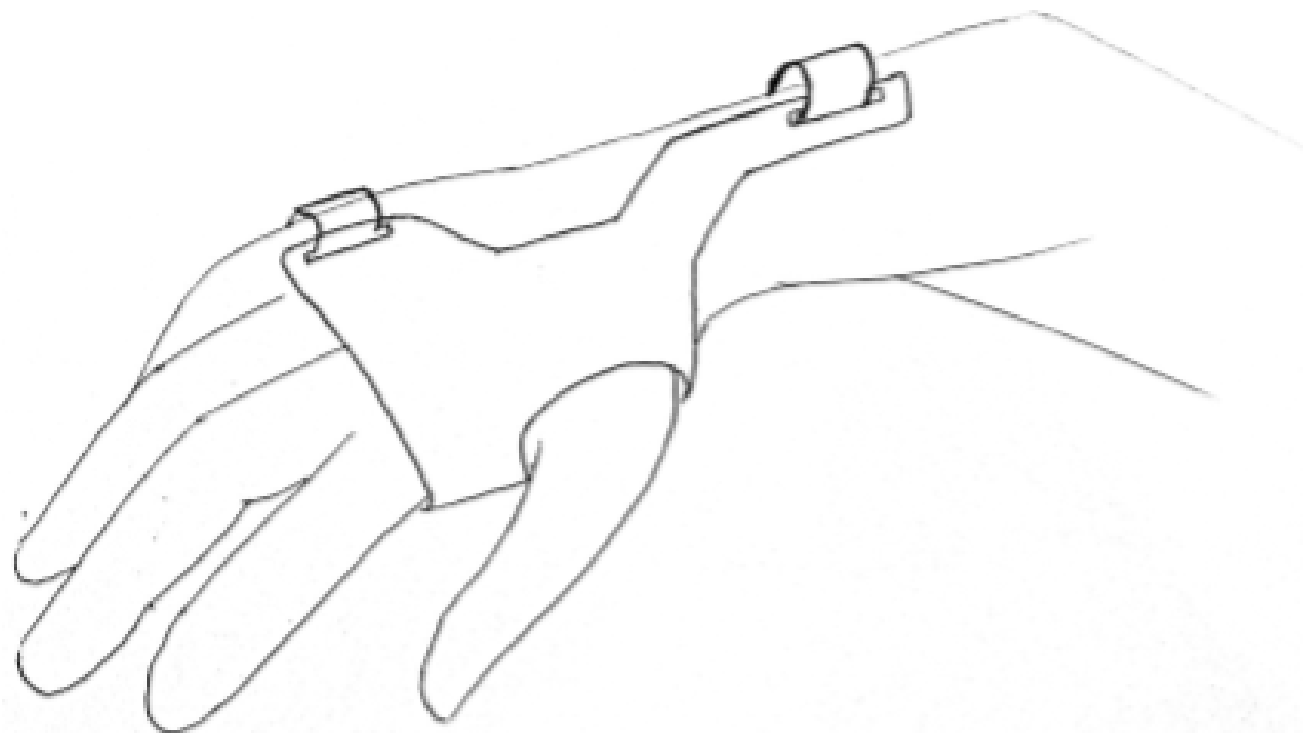
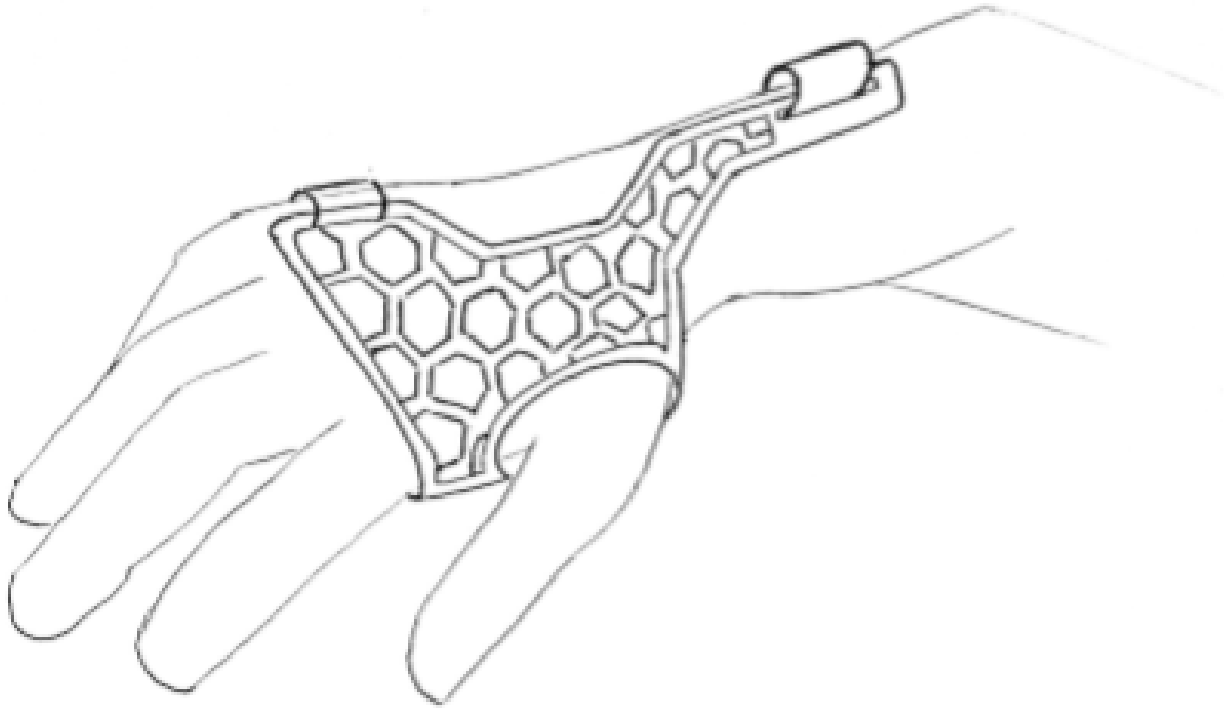

SKETCH N°12

SKETCH N°13

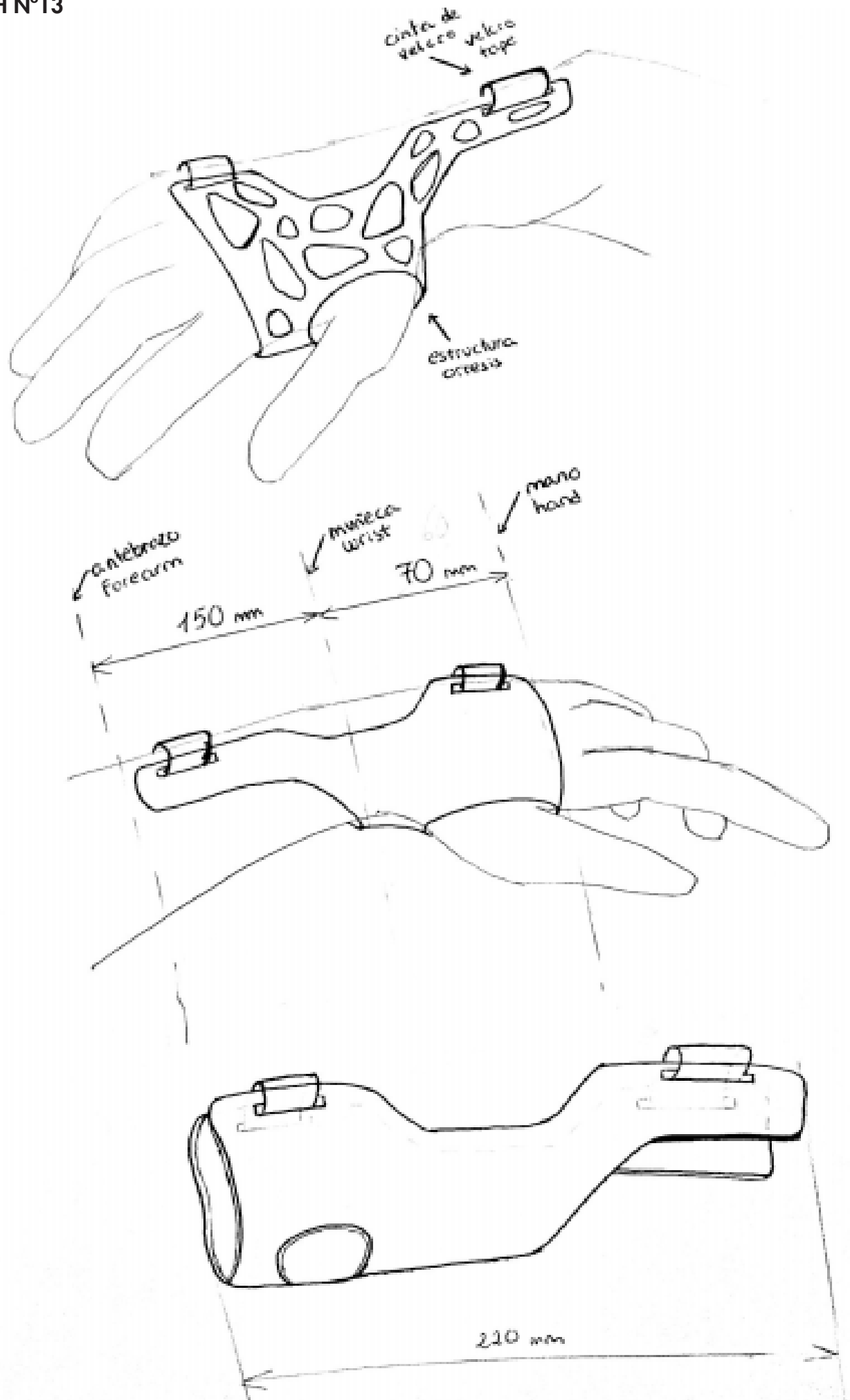

SKETCH N°14

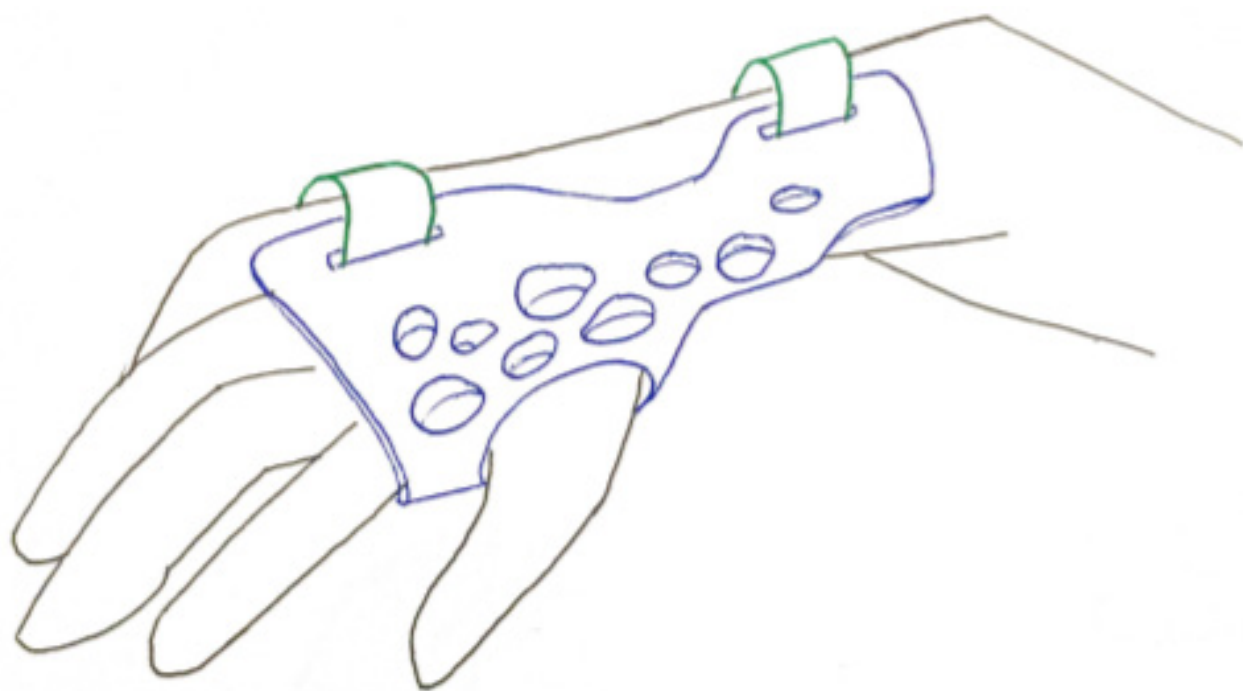
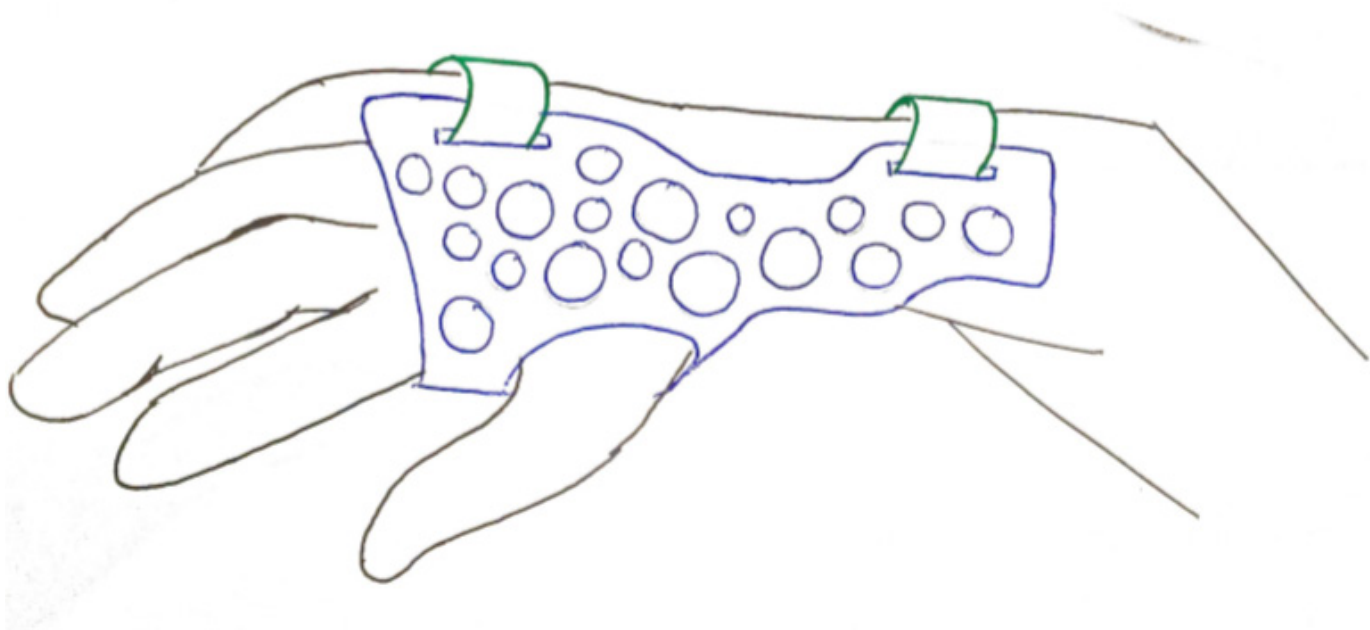

SKETCH N°15

SKETCH N°16

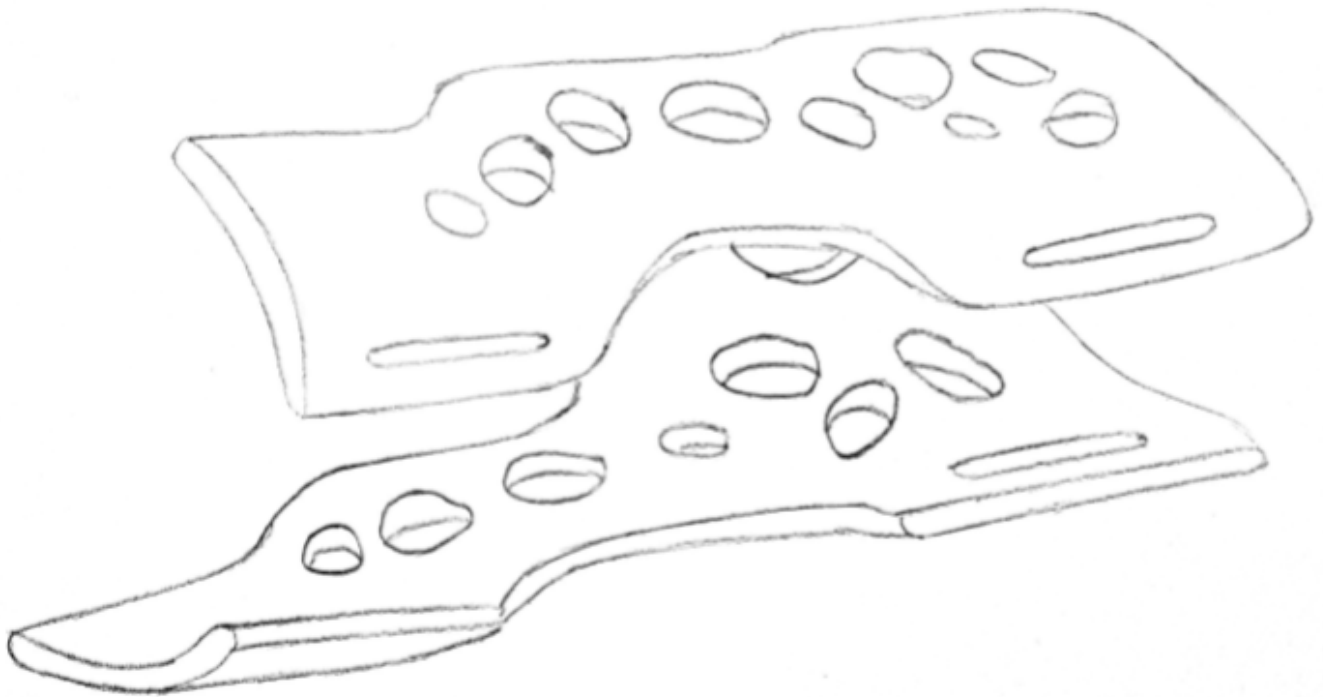

Orthosis structure.

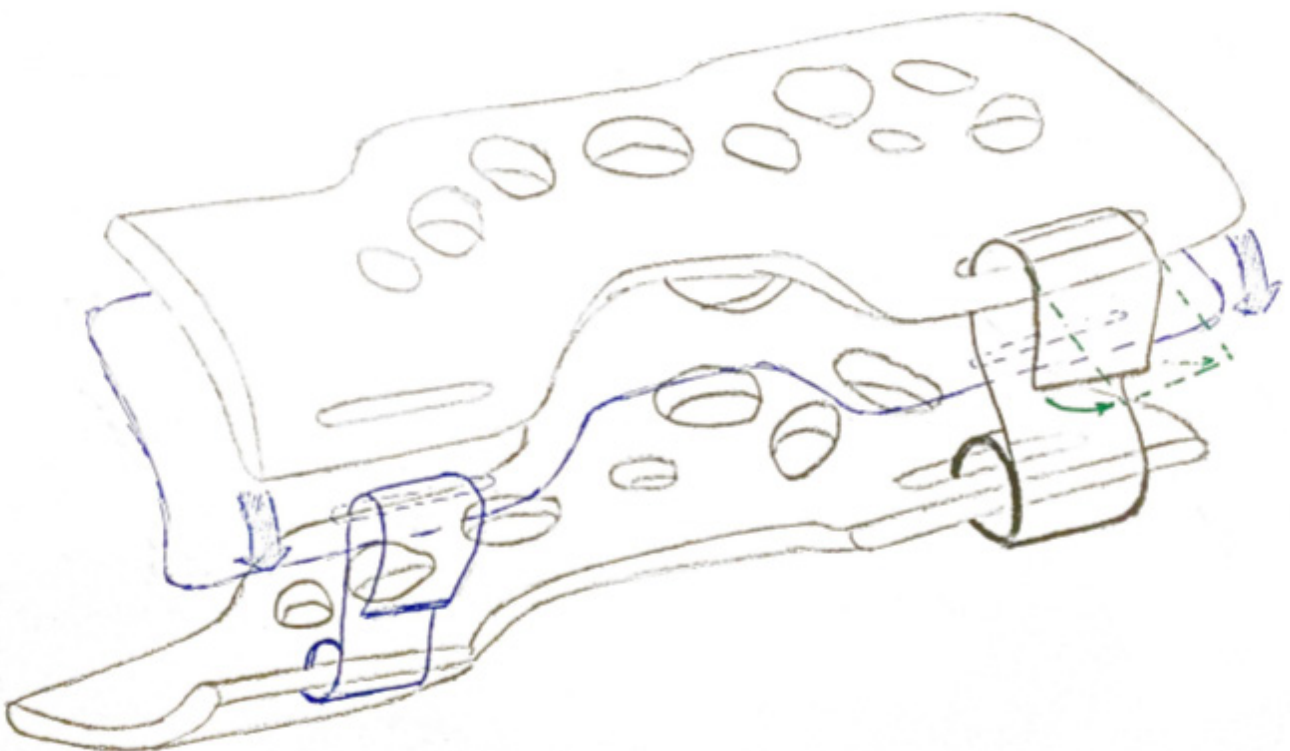

Velcro system.

SKETCH N°17

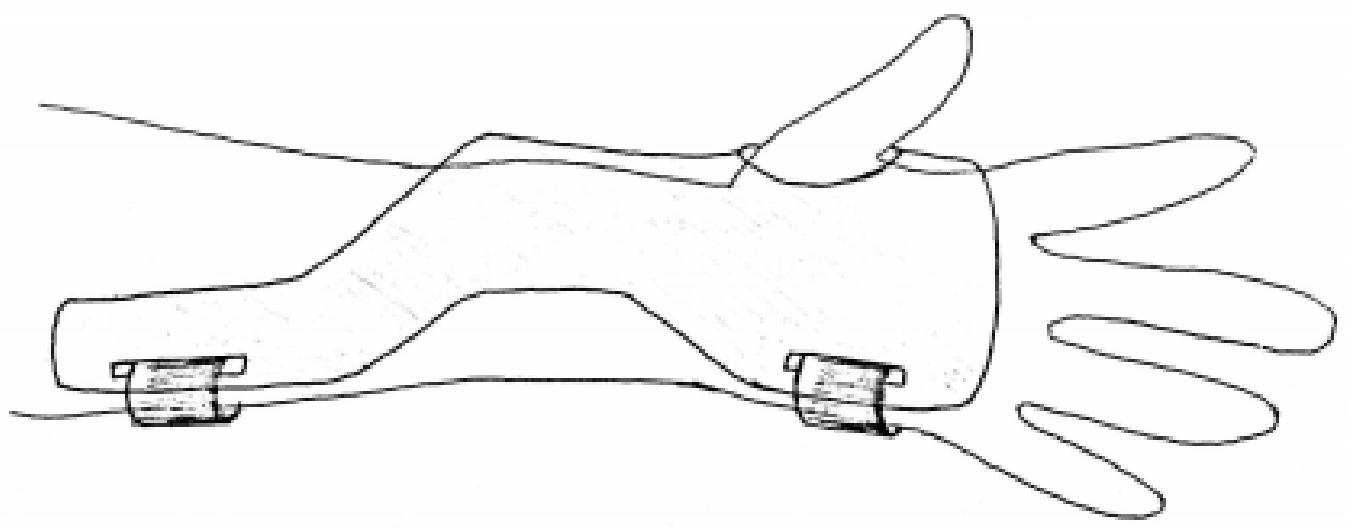
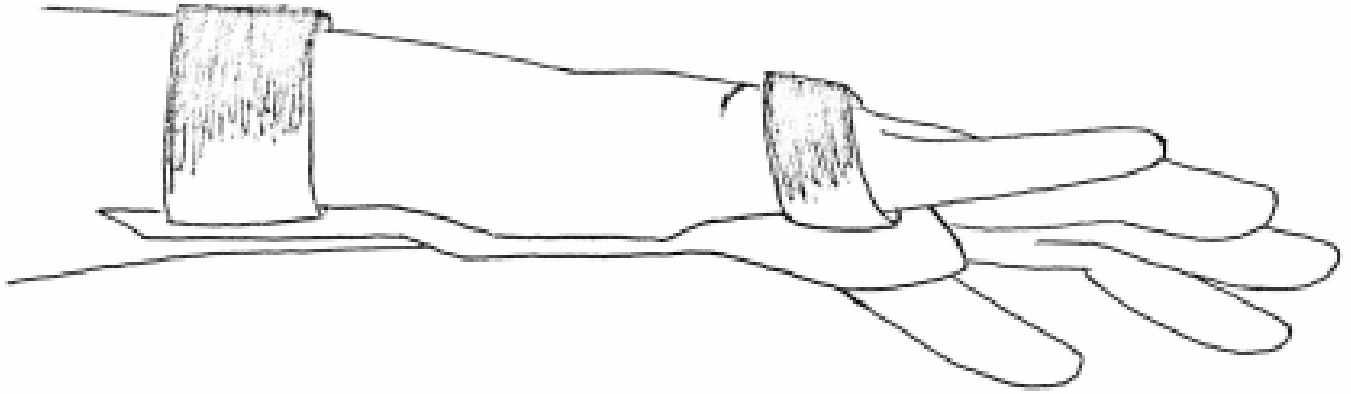

DESIGN PROCESS

6

Once all kind of information about the orthosis is known, after a huge and clear state of art has been studied and after a table whose content is a list of requirements that orthosis must satisfy has been made, it is time to develop the design process.

The first step to follow in the design process is to know the anthropometric measurements of the patient's arm. This has to be known in order to find out the appropriate orthosis measures and to carry out its construction in CAD.

After the dimensions are known, the next step to follow is to know the used manufacturing process. What means to find out in which type of 3D printer the piece is going to be made and therefore the final material chosen. It also is going to be studied the external elements that the orthosis presents, such the union elements are.

5. DESIGN PROCESS

5.1. MEASURE

The first step in the orthosis design process is to take the anthropometric measurements of the patients' arm. In this case, three patients of different dimensions have been chosen, each one referring to a size. So the orthosis will be available in three different sizes as small (S), medium (M) and large (L).

The indispensable measures that must be taken into account for a correct arm measurement are the following:

- **Regarding the hand:** it is necessary to measure the width by the palm of the hand at the level of the metacarpophalangeal joints.

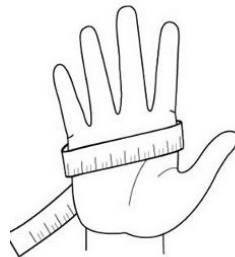

- **Regarding the wrist:** it is necessary to measure the perimeter of the wrist, adjusting it as much as possible to the area where the watch is placed

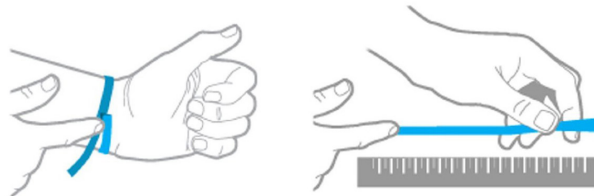

- **Regarding the forearm:** it is necessary to measure the perimeter of the forearm at a distance of 15 cm from the wrist.

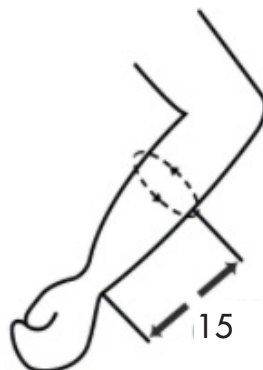

In order to define the orthosis dimensions, it is needed to know the three measures named before. Once the way to find out this measures has been studied, it is proceeded to collect the data of the three different patients.

Next, it is going to be shown the table in which the data of the three patients according to their corresponding size is collected. Futhermore, it has been decided to apply a range to the sizes to cover a larger audience. All the measures that appear are in cm:

	WIDTH	WRIST	FOREARM
SMALL	6,3-7,6 cm	12,5-15 cm	19-23,5 cm
MEDIUM	7,6-9 cm	15-17,7 cm	23,5-26,6 cm
LARGE	9-10 cm	17,7-20 cm	26,6-30,4 cm

As a conclusion of this table, it could be said that the orthosis is going to be available in three different and regulable sizes because it is wanted to look for an adjustable design to get a 100% personalized orthosis.

The objective of the orthosis design is to satisfy the needs of as many people as posible. This is why it could be available in different sizes and could be adjustable, with the aim of covering a larger number of patients. Below, the three sizes named before with the general measures are shown. It must be said that in the rest of the proyect, the small size (S) has been the one chosen for the plans and the load simulation study.

SIZE SMALL

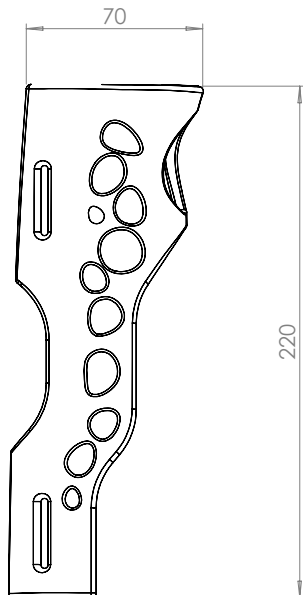
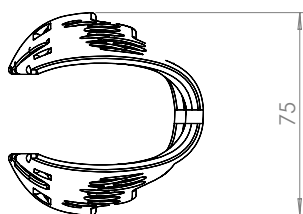

SIZE MEDIUM

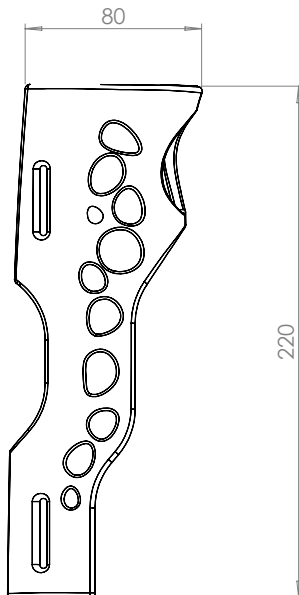
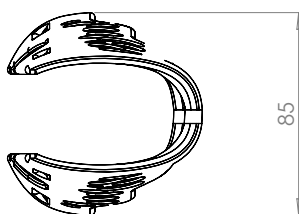

SIZE LARGE

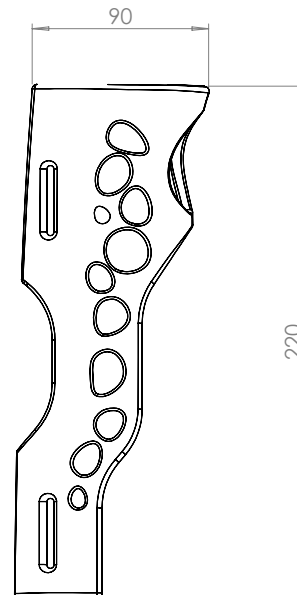
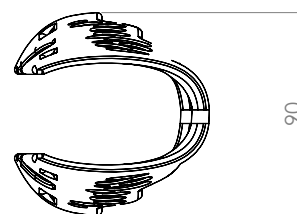

5.2. JUSTIFICATION OF THE MATERIAL CHOICE

As we have seen in the section of the technical literature, over the years, various materials for the creation of orthoses have been used. Currently, the most demanded are thermoplastic materials due to the advantages they have over conventional ones. Therefore, the final material chosen for the realization of the product is the PLA (Polylactic Acid), since it is one of the most used materials in 3D printing and also it has the mechanical characteristics that are required for the realization and subsequent use of the object.

Polylactic Acid (PLA) is different than most thermoplastic polymers in that it is derived from renewable resources like corn starch or sugar cane. It is biodegradable and has characteristics similar to polypropylene (PP), polyethylene (PE), or polystyrene (PS).



There are a vast array of applications for Polylactic Acid. Some of the most common uses include plastic films, bottles, and biodegradable medical devices (e.g. screws, pins, rods, and plates that are expected to biodegrade within 6-12 months). PLA constricts under heat and is thereby suitable for use as a shrink wrap material. Additionally, the ease with which Polylactic Acid melts allows for some interesting applications in 3D printing.

PLA is classified as a "thermoplastic" polyester. Thermoplastic materials become liquid at their melting point (150-160 degrees Celsius in the case of PLA). A major useful attribute about thermoplastics is that they can be heated to their melting point, cooled, and reheated again without significant degradation. Instead of burning, thermoplastics like Polylactic Acid liquefy, which allows them to be easily injection molded and then subsequently recycled.

- PROPERTIES OF PLA

Density	1210 - 1250 Kg/m ³
Young's modulus	3.45 - 3.83 GPa
Elastic limit	48 - 60 MPa
Tensile strength	48 - 60 MPa
Compressive strength	48 - 60 MPa
Melt temperature	160 - 177 °C
Poisson coefficient	0.38 - 0.4
Price	1 kg = 20 €

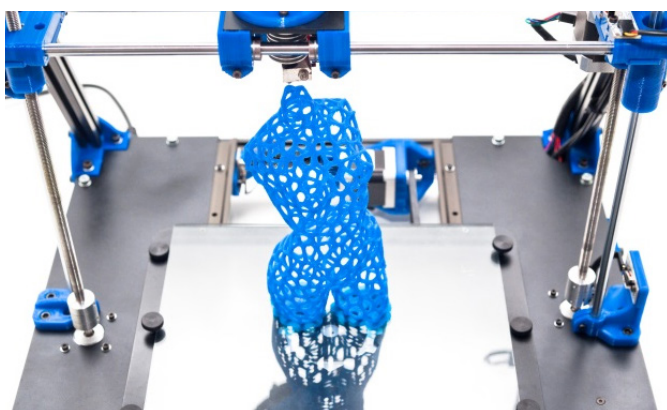

5.3. MANUFACTURING PROCESS USED

The piece is going to be produced through the additive manufacturing, in particular, with the XEED 3D printer. On the website it is described as:

“A high precision, professional printer made affordable”

The Xeed 3D Printer has no equal when it comes to precision and price. The heated bed chamber, touchscreen and wifi connection gives it the edge your projects are looking for. Print quality, consistency and repeatability is assured with Leapfrogs’ PerfectLevel system, which calibrates the bed perfectly before each print. Due to the continuously heated environment the Xeed can make high quality prints, using a large range of materials. The heated environment will optimize adhesion between layers ensuring maximum strength of your 3D prints.

- FEATURES

Automatic bed calibration (patented).

Highest precision (10 micron).

Cross platform wifi compatible.

Automatic filament loading and detection.

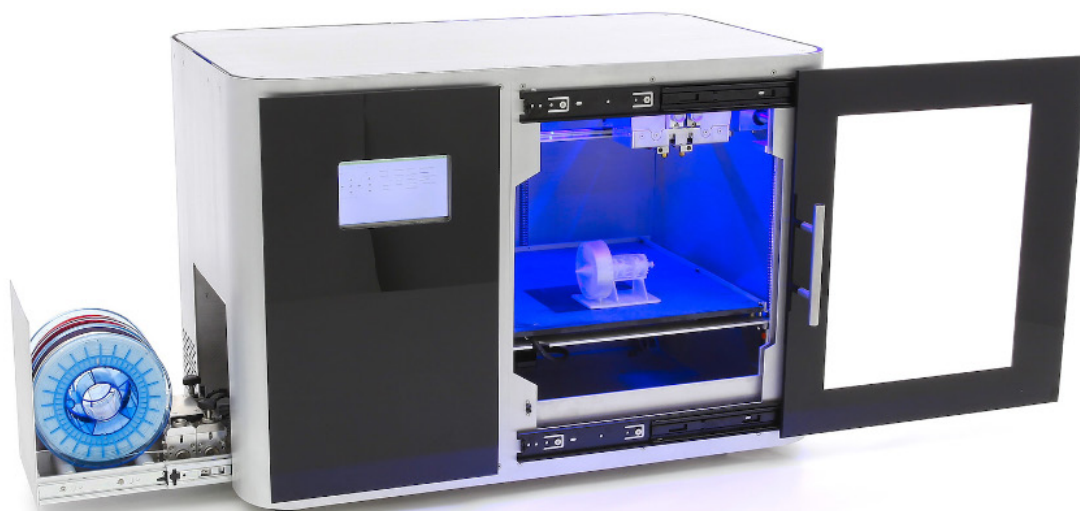

5.2. CONNECTING ELEMENTS

The only connecting element that is going to be used in the manufacture and assembly process of the orthosis will be Velcro. Velcro belongs to the group of detachable connections, meaning that they are used in cases where manual separation of the “connected” elements is intended, or with some ease.

The brand name of a type of fastening tape consisting of opposing pieces of fabric, one piece with a dense arrangement of tiny nylon hooks and the other with a dense nylon pile, that interlock when pressed together. Velcro is a quick opening and closing system.

For the design of this orthosis, it has been decided to use two velcro bands, the first, securing the closure on the forearm section, and the second, on the section on the wrist. In addition to providing a safety lock, this object provides the opportunity for this to be an adjustable orthosis. This closure system also helps in the medical process, since, as is well known, there can be moments of swelling, so, thanks to the velcro bands, the orthosis can be adjusted to offer greater comfort.

- Following are the measures of velcro bands have used:

For forearm part:	25x200 mm
For wrist part:	25x160 mm

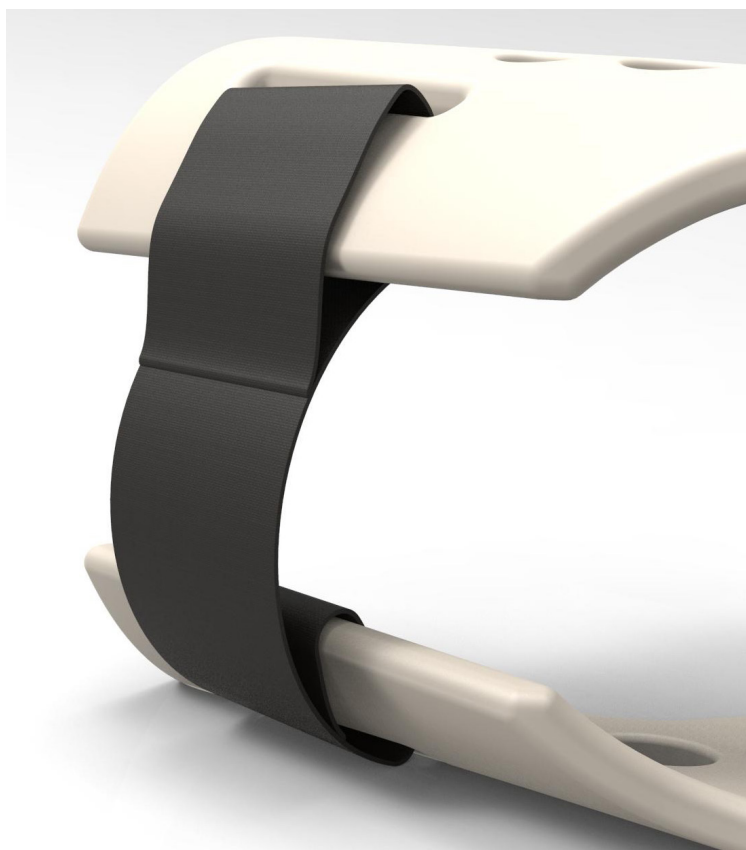

3D

MODEL

7

To generate the model in CAD, the software SolidWorks has been chosen as the program to be used. The essential data to be able to build a good structure for the orthosis, are the anthropometric measurements which have been previously taken of the patients. In addition to these measurements, the file of the scanned arm has been imported, which will serve as a guide to the modelling of all operations for the orthosis construction. Thanks to the arm, this structure can be modified to achieve a perfect fit to the patient's arm.

It must be said, that the measures used to carry out the CAD have been those corresponding to size small (S).

7.1. CONSTRUCTION

As previously discussed in the introduction, for the construction of the orthosis two important points are necessary, firstly, the scanned arm, and secondly, the anthropometric measurements. The first step to make the model in 3D, is to open the file in which the image of the scanned arm is located.



Once the file is opened, the sketch of the measurements is drawn. For the sketch, three drawings are drawn, corresponding to each small size (S) measurement, which are, the perimeter of the forearm (plane 1), the perimeter of the wrist (plane 2) and the hand's breadth (plane 3). This way, the orthosis construction will be easier, since, to start from correctly adjusted measurements, a stabilizing orthosis will be achieved.

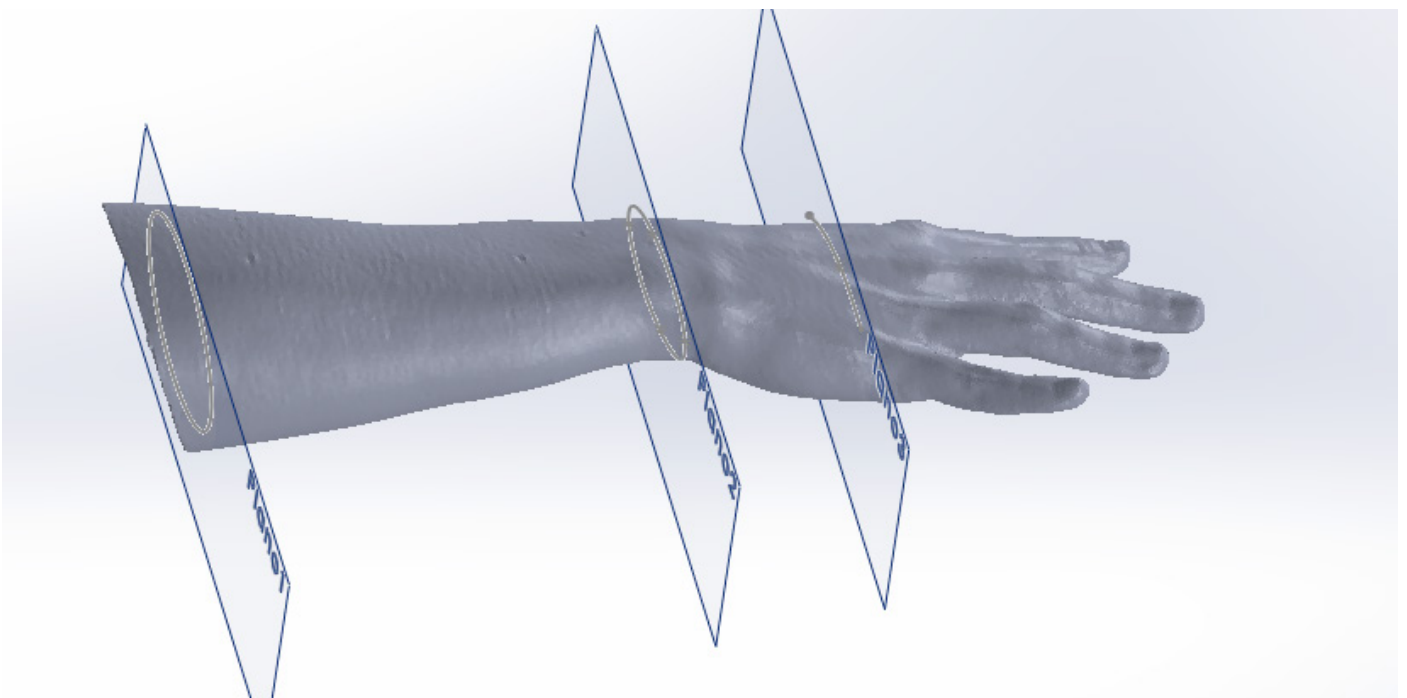

The structure has been created by surfaces, where the tool “lofted surface” has been used, and the 3 edges corresponding to the measurements have been selected. Then, the previously created surface has been thickened and part of the structure has been cut to achieve the desired aesthetics. Also, the whole piece has been rounded off for a better result. Finally, a sketch has been made on the top face, where holes of random size and position are created, thanks to which better ventilation and hygiene will be possible.

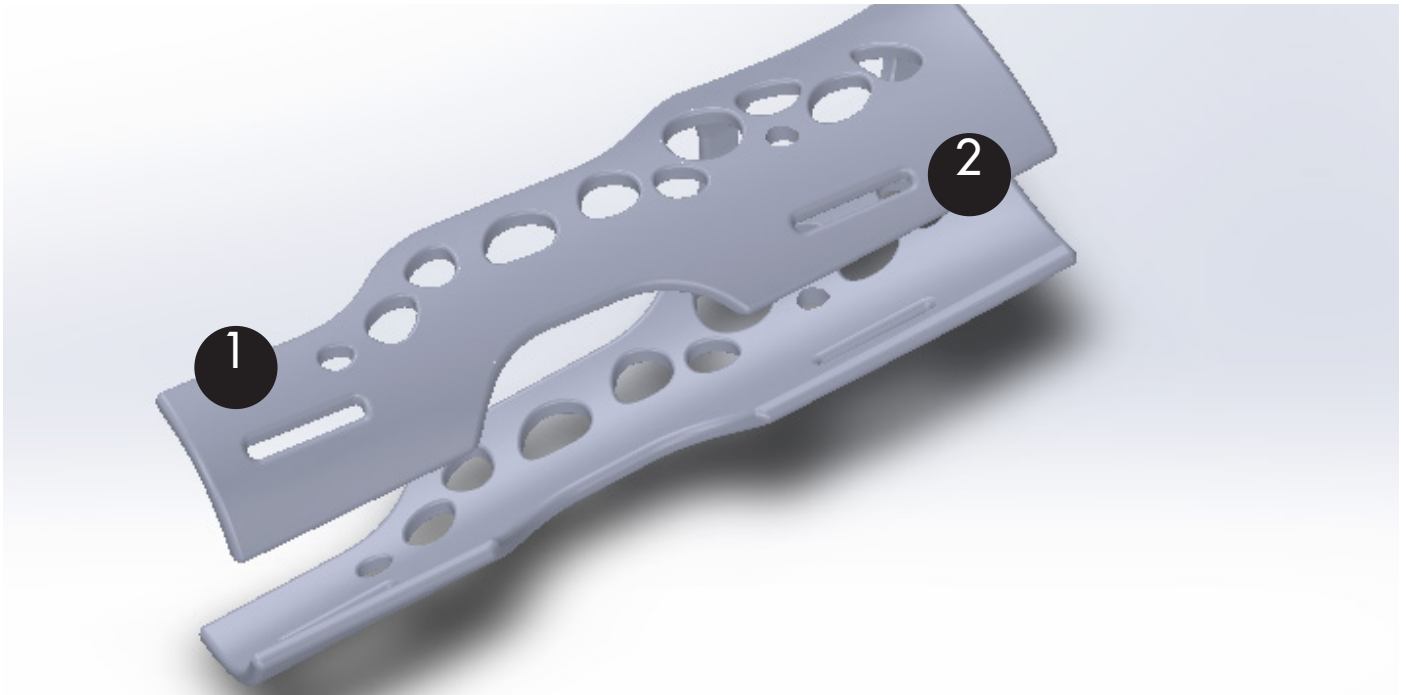

The two grooves on the side of both the upper and lower sides refer to the velcro holes. Two velcro tapes will pass through these holes that will serve to both close and adjust the orthosis.

VELCRO 1

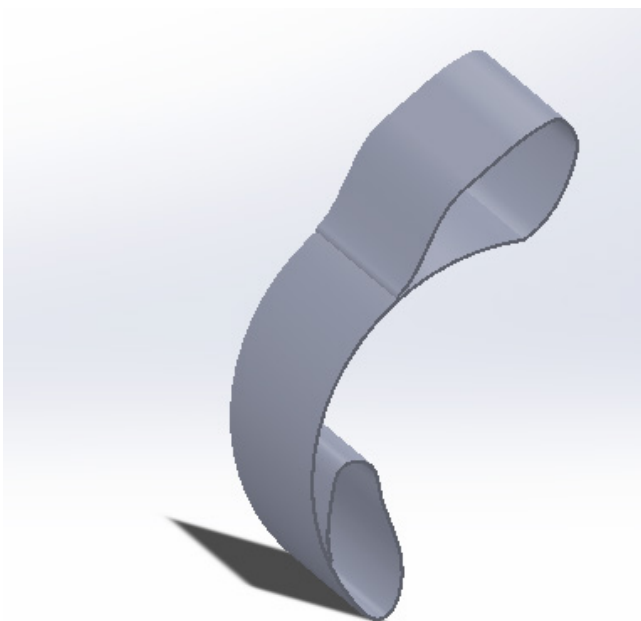

VELCRO 2



Last but not least, the assembly is going to be made between the three components. The orthosis structure and the velcro bands are the parts of it, so a 3D model is going to be made.

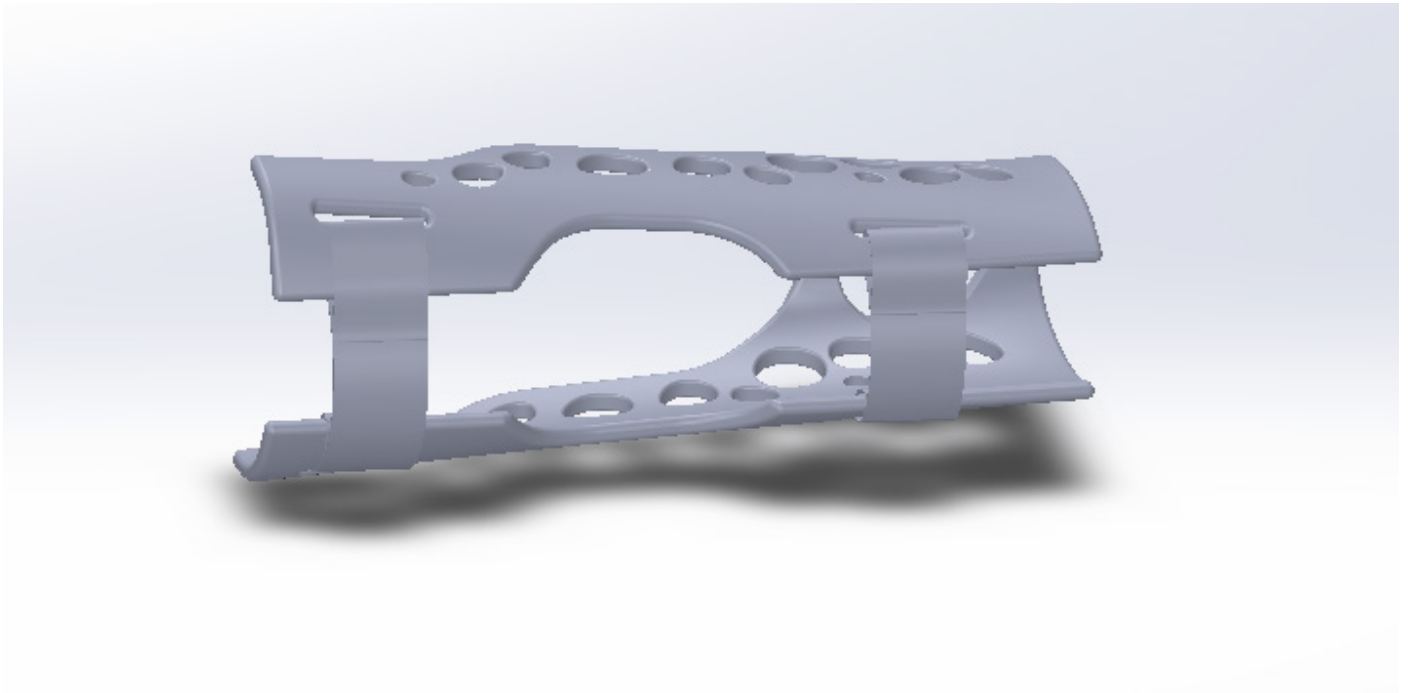

In the following pictures it can be observed how the orthosis is attached to the patient's arm. At first glance, it can be said that the orthosis has adequate dimensions for its function.



Once the 3D model is done and using the same software, the volumetric properties obtained as the mass, volume or weight, are checked and collected in the following table:

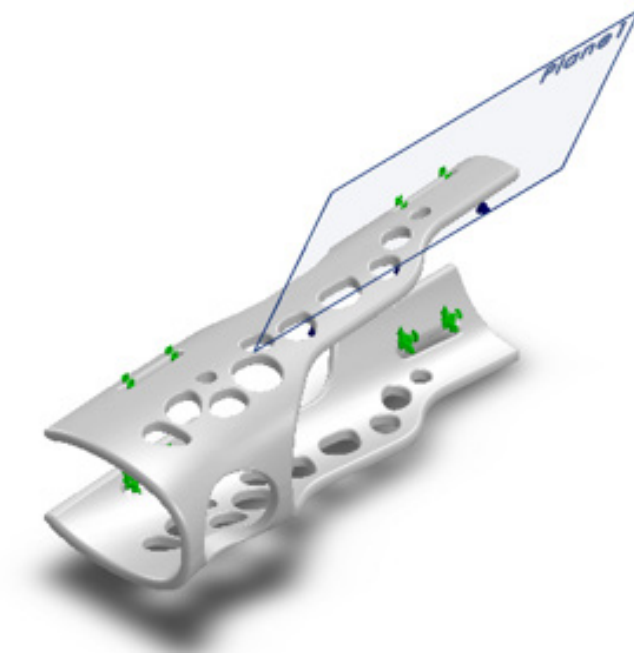

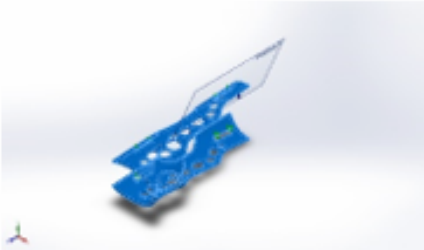
Document Name and Reference	Treated As	Volumetric Properties
	Solid Body	<p> Mass:0.124712 kg Volume:0.000102223 m³ Density:1220 kg/m³ Weight:1.22217 N </p>

As final result it has been obtained a mass of 0,125 kg (125 g). A rather small value, so it can be said that the designed orthosis is a low weight orthosis, and that therefore it has been possible to satisfy the needs of a light and comfortable orthosis for the patient.

DRAWINGS

8

In this section, the associated drawings to the final product have been carried out, the first drawing that to be observed, is the overall drawing of the orthosis, where the overall dimensions of the product and the list of items appear, in the last one, data as a quantity, mark or material, can be observed.

The second drawing that will be displayed, is the detailed dimensions of the object 1 (orthosis structure). In this, all necessary measures to carry out the structure construction will appear.

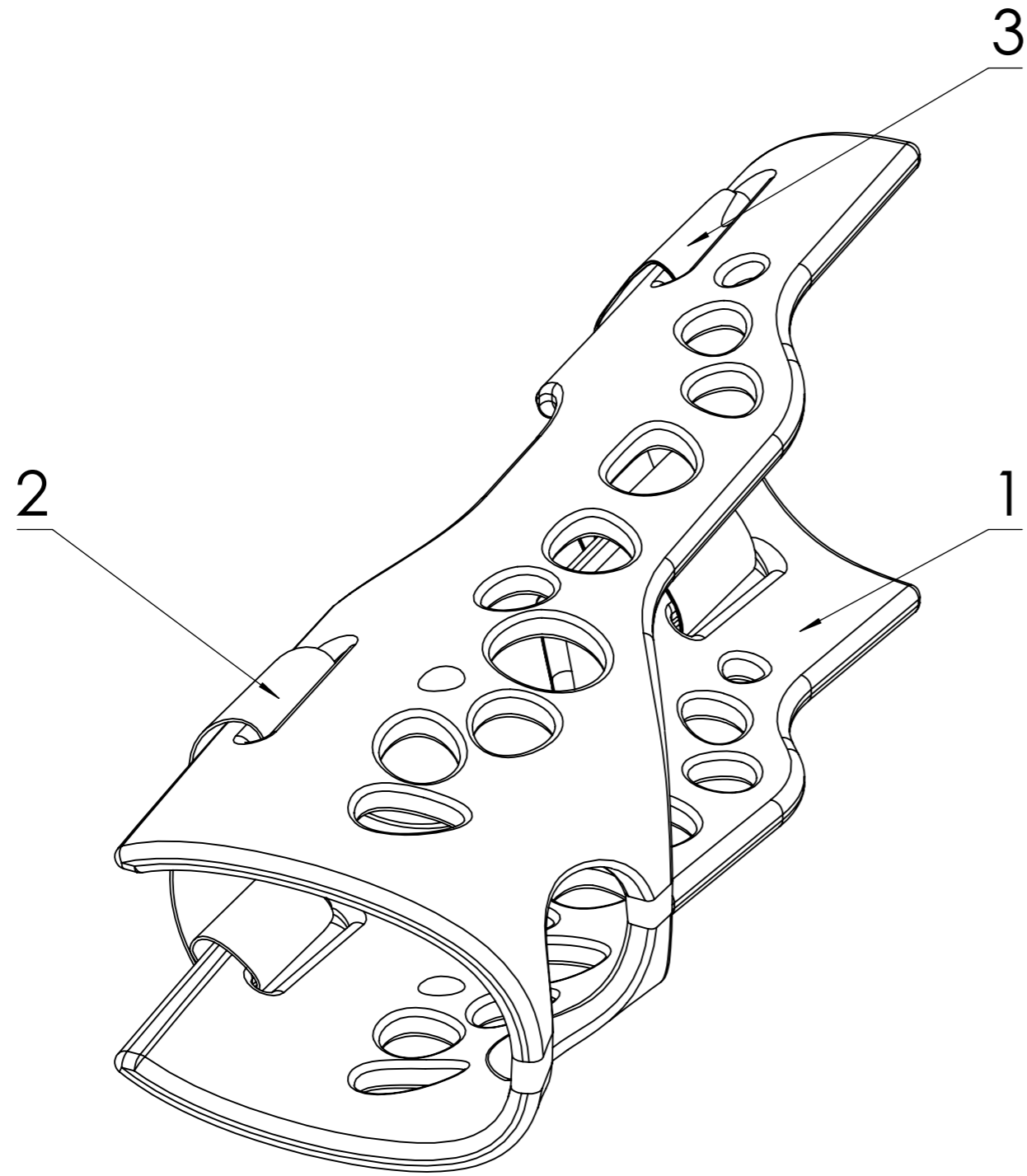

SCALE 1:1

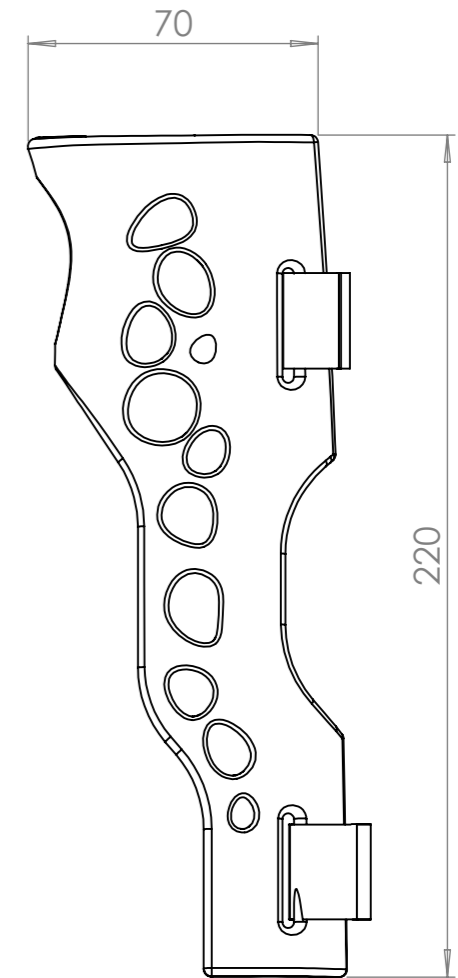
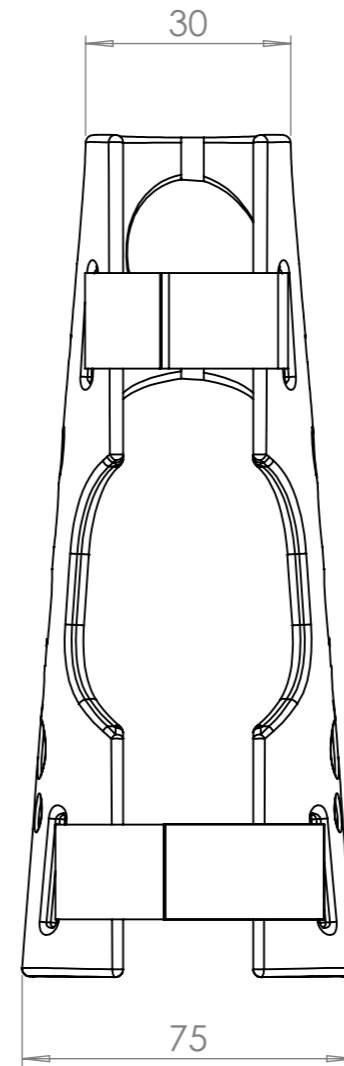

MARK	DESIGNATION	QUANTITY	REFERENCE	MATERIAL
3	FOREARM BAND (25x200mm)	1		VELCRO
2	WRIST BAND (25x160mm)	1		VELCRO
1	ORTHOSES	1		PLA

UNIVERSIDAD POLITÈCNICA
DE VALÈNCIA
CAMPUS D'ALCOI

TITLE: 3D PRINTED ORTHOSIS DESIGN

Revised by:

Unit: mm

1° SURNAME: AGUADO

DATA:

SCALE:
1:2

2° SURNAME: PÉREZ

PAGE:

Mark:



NAME: Judit

1

Degree: Industrial Design

8 7 6 5 4 3 2 1

F
E
D
C
B
A

F
E
D
C
B
A

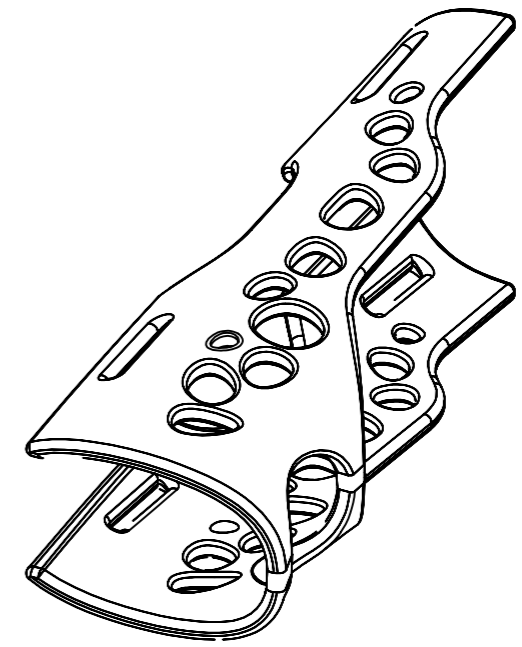
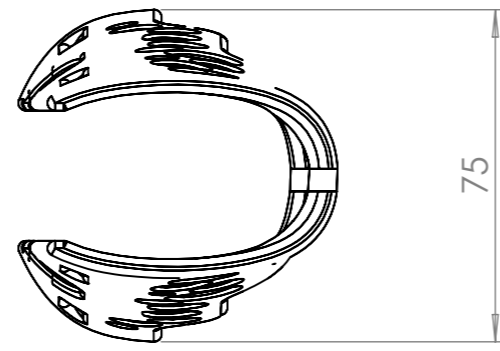
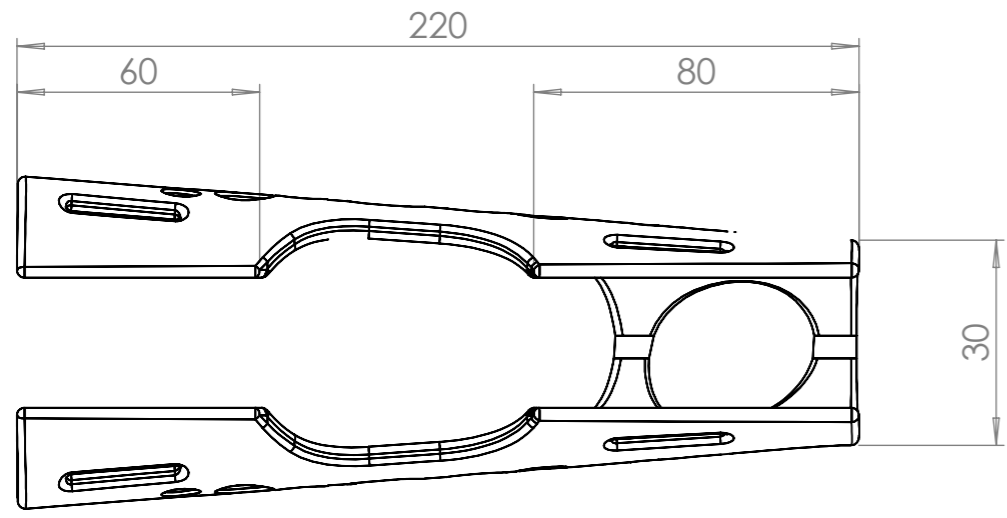

THE HOLES HAVE RANDOM POSITIONS AND RADIUS

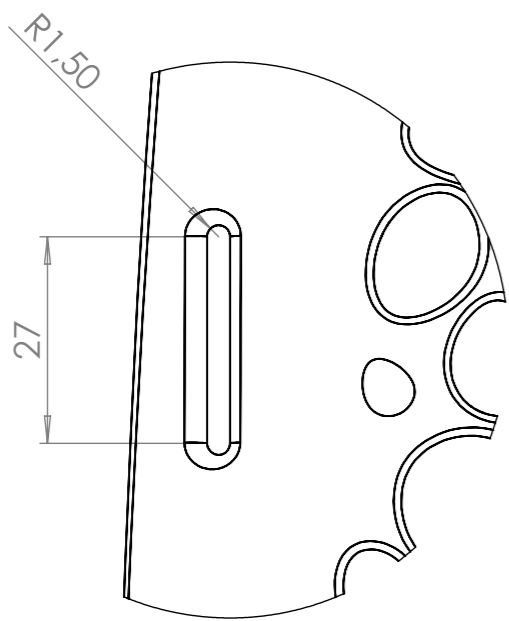

DETALLE A
ESCALA 1:1

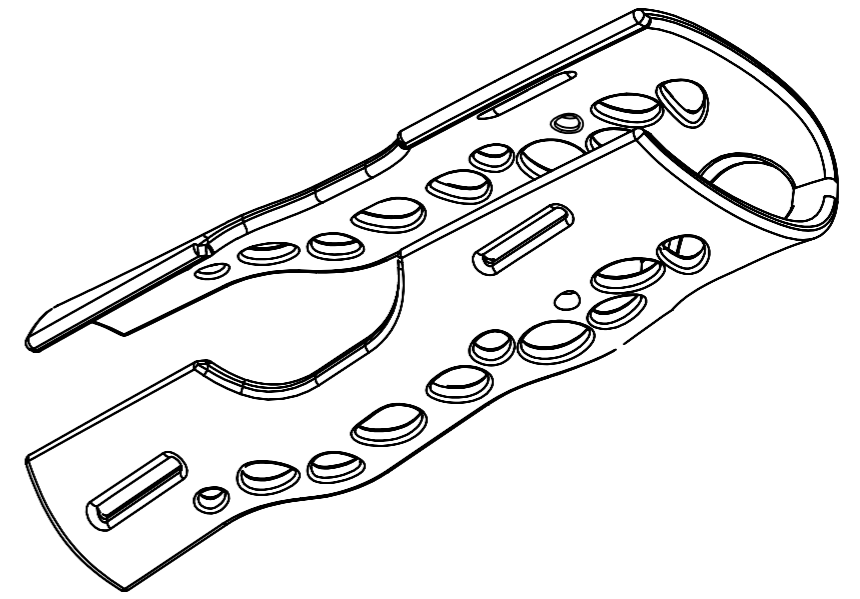
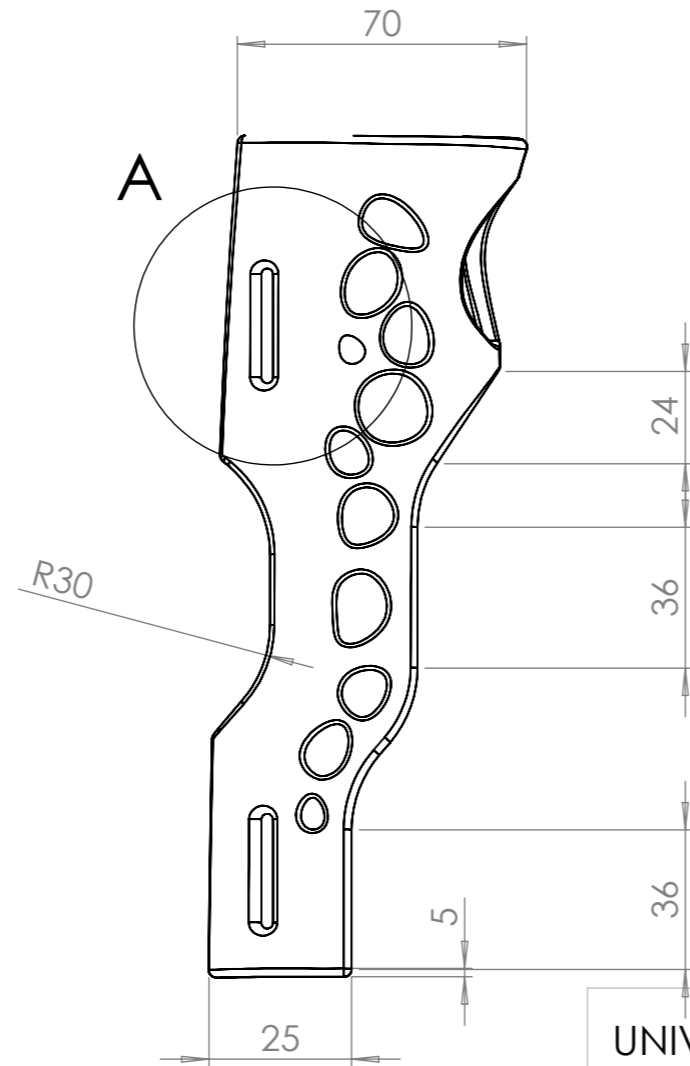

ROUNDING 2mm IN THE HOLE PIECE

UNIVERSIDAD POLITÈCNICA DE VALÈNCIA CAMPUS D'ALCOI		TITLE: 3D PRINTED ORTHOSIS DESIGN	
Revised by:	Unit:	1° SURNAME: AGUADO	DATA: 18/05/18
	SCALE: 1:2	2° SURNAME: PÉREZ	
Mark:		NAME: Judit	PAGE: 2
		Degree: Industrial Design	

8 7 6 5 4 3 2 1

LOAD SIMULATION

9

This section covers the simulation of how weight affects the piece. For this, the software SolidWorks has been chosen as the program to be used. Using this software, one study have been made, where the fixtures and the elastic support are applied. In order to carry out such study, it is necessary to know the mechanical properties of the material, as well as the position of the restrictions. Thanks to these studies, it is possible to see the reaction of the orthosis when a force is applied, in this case, imitating human strength.

Once the simulation study has been made, the first step to follow must be to choose the object material. So in this step it has to be selected “apply the material” and create so a new custom material. The PLA mechanical properties (named previously) have to be indicated in this creation.

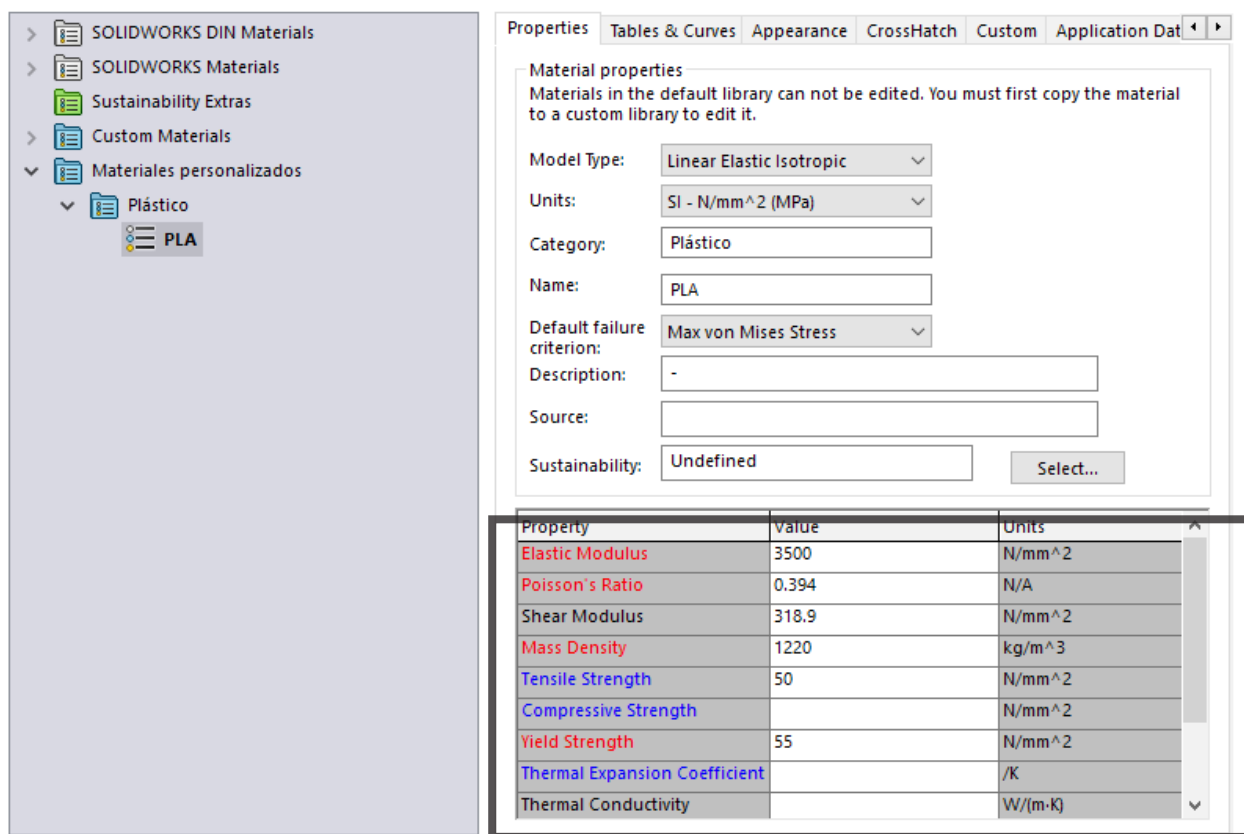

The next step is to place the restrictions, in this case, a fixation type of fixed geometry has been chosen. It has been decided to place them in the two orifice that the underside face of the orthosis presents. The reason for this placement is due to the velcro behavior that was wanted to be observed. To achieve this it is necessary to place a fixed part and another that makes the displacement.

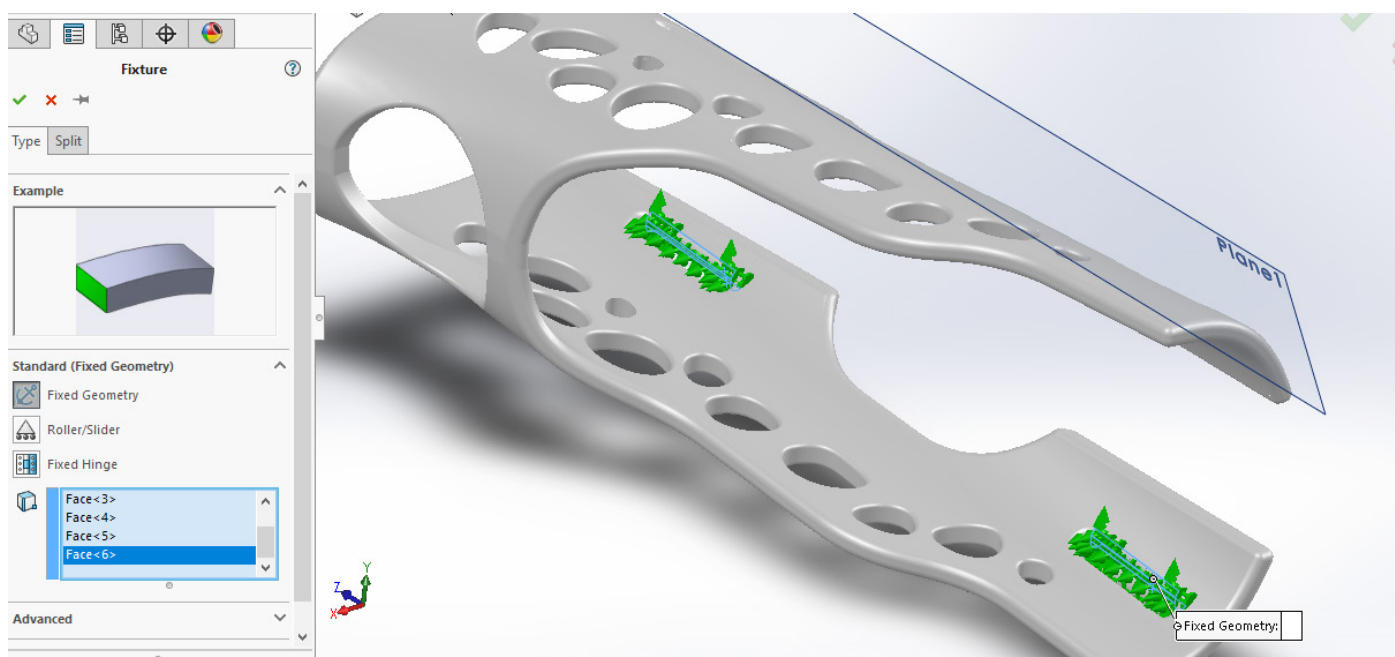

Hereunder, the displacement restriction has to be placed on the orthosis top face. For placing the restriction, both faces of the velcro orifice and a plane as a reference to the direction, are needed. The translation will be 3mm.

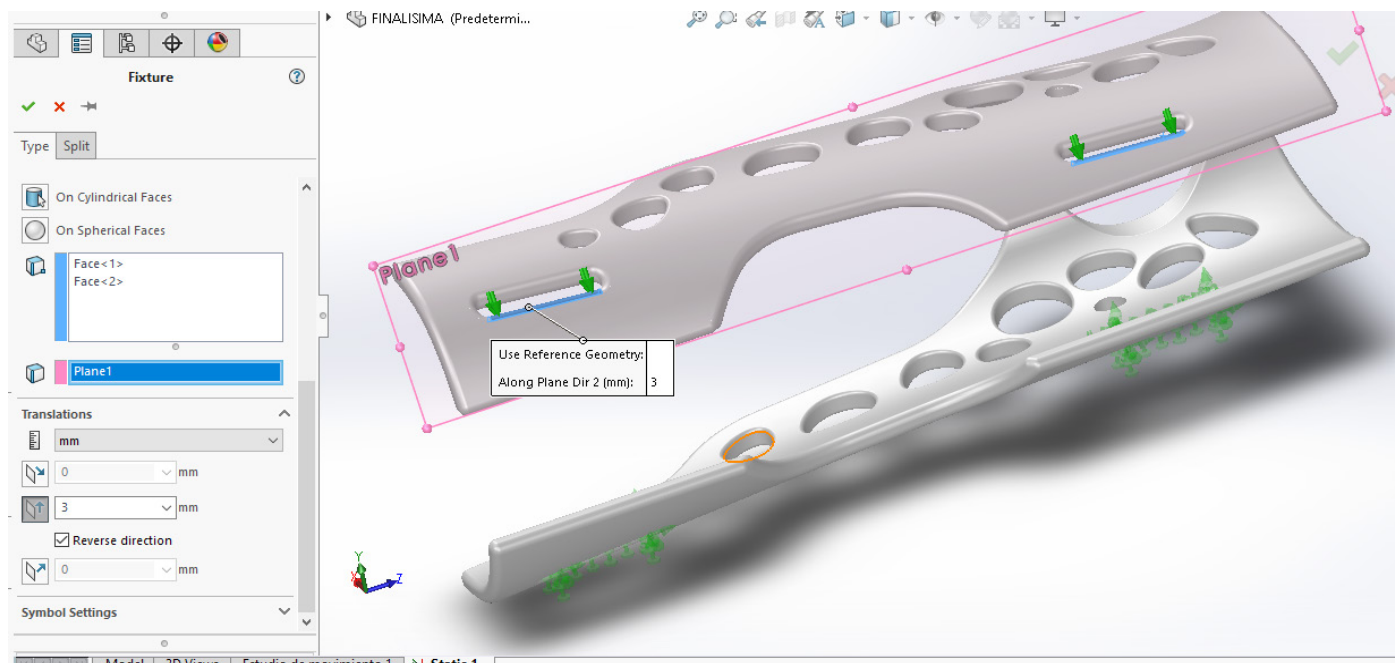

The last entity to be placed is the elastic support, which is going to be placed on the internal face of the upper part of the orthosis top face. Its stiffness value is $1000(N/m)/m^2$.

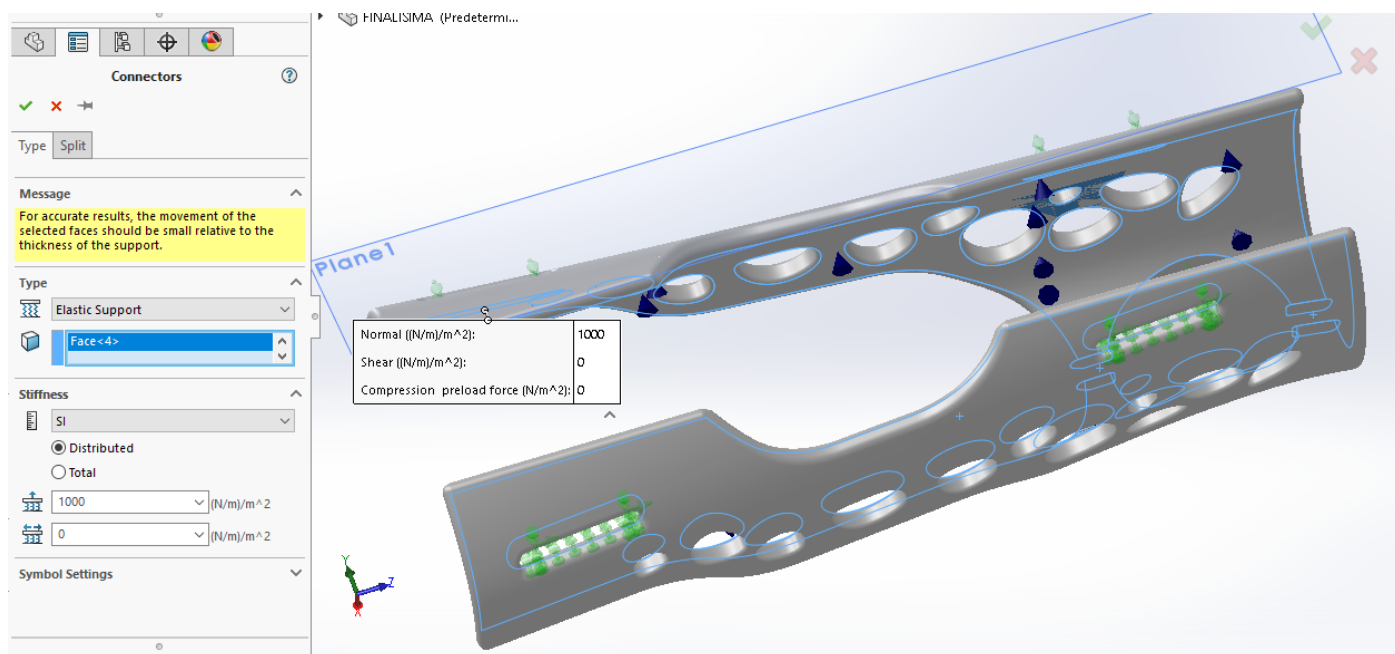

Once all the elements are placed, the study analysis is going to be done. Hereunder, the report published by the SolidWorks software is shown. In which is possible to analyze the results obtained from the previous study. Through this report, the mesh obtained can be observed in detail. As well the behavior that Velcro will suffer through the results of tensions, displacements or unit deformations, is going to be shown.

REPORT OF SIMULATION (SOLIDWORKS)

- LOADS AND FIXTURES

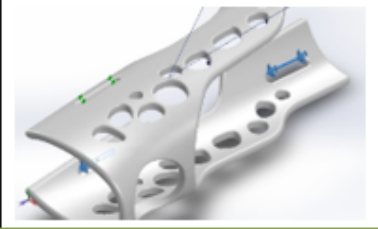
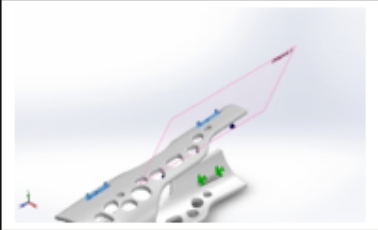
Fixture name	Fixture Image	Fixture Details		
Fixed-2		Entities: 2 face(s) Type: Fixed Geometry		
Resultant Forces				
Components	X	Y	Z	Resultant
Reaction force(N)	15.4572	35.1681	-0.000798583	38.4151
Reaction Moment(N.m)	0	0	0	0
Reference Geometry-2		Entities: 2 face(s), 1 plane(s) Reference: Plane1 Type: Use reference geometry Translation: ---, -3, --- Units: mm		
Resultant Forces				
Components	X	Y	Z	Resultant
Reaction force(N)	-15.4813	-35.2499	0	38.4997
Reaction Moment(N.m)	0	0	0	0

- CONNECTOR DEFINITIONS

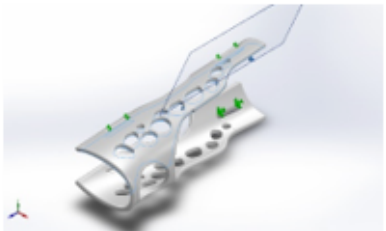
Connector Name	Connector Details	Connector Image
Elastic Support-2	Entities: 1 face(s) Type: Elastic Support Normal stiffness value: 1000 Shear stiffness value: 0 Units: (N/m)/m ²	 Elastic Support-2

- MESH INFORMATION

Mesh type	Solid Mesh
Mesher Used:	Standard mesh
Automatic Transition:	Off
Include Mesh Auto Loops:	Off
Jacobian points	4 Points
Element Size	6.38399 mm
Tolerance	0.319199 mm
Mesh Quality	High

Details

Total Nodes	20712
Total Elements	10518
Maximum Aspect Ratio	30.823
% of elements with Aspect Ratio < 3	54.9
% of elements with Aspect Ratio > 10	2.17
% of distorted elements(Jacobian)	0
Time to complete mesh(hh:mm:ss):	00:00:23
Computer name:	

Model name:FINALISIMA
 Study name:Static 1(-Predeterminado-)
 Mesh type: Solid Mesh

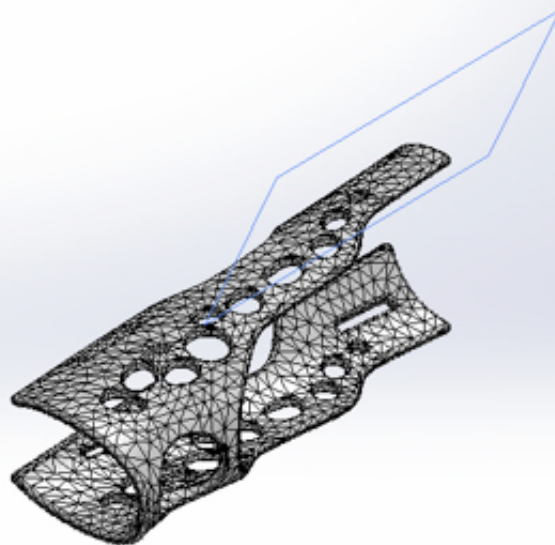

- STUDY RESULTS

Von Mises Stress

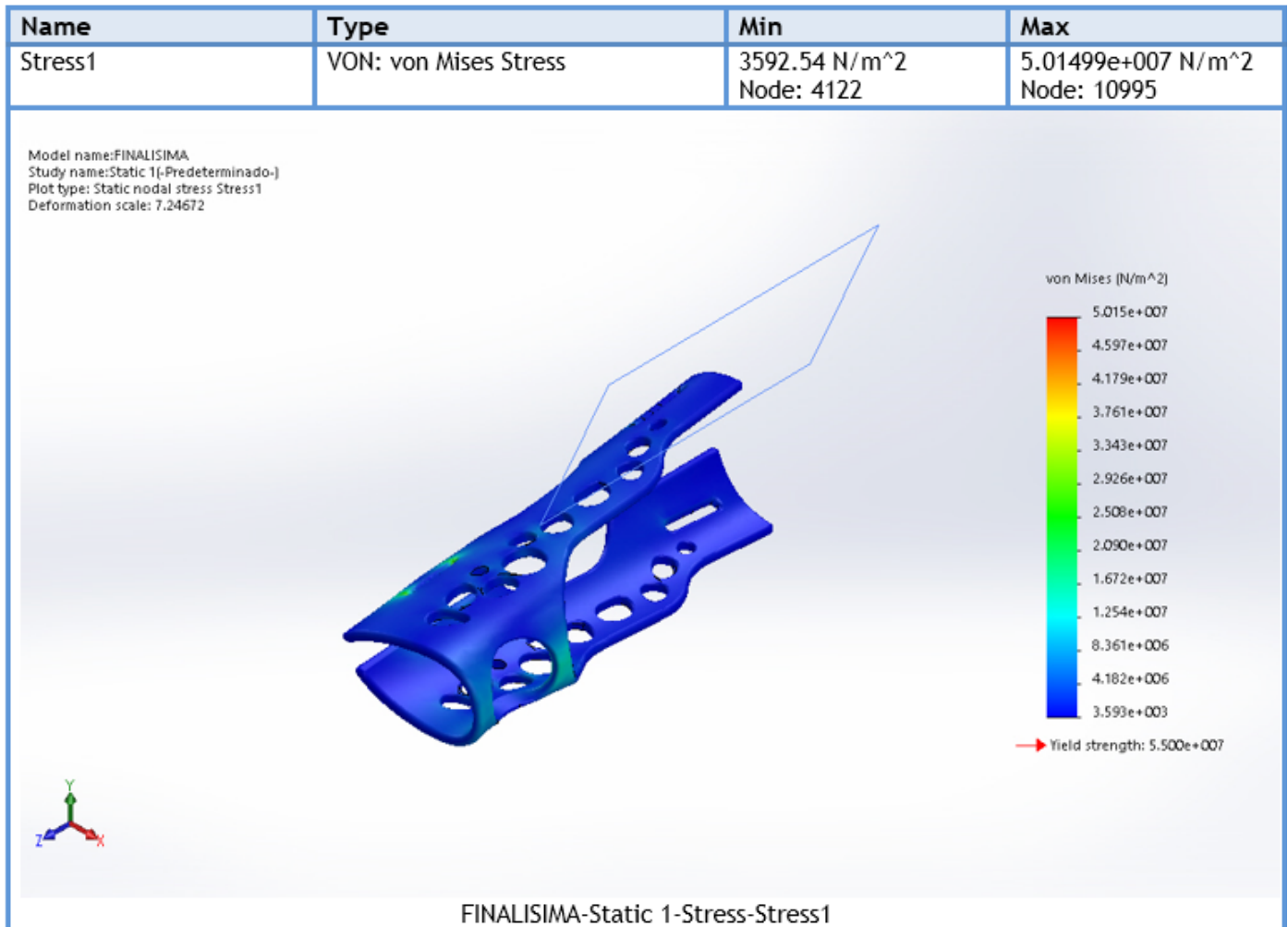

As a conclusion of the previous picture, it can be said that the obtained results regarding to the "Stress" are acceptable. It can be observed that the maximum obtained value of the stress (**5.015e+007 N/m²**) is not higher than the elastic limit (**5.500e+007 N/m²**). This values mean that the structure will never broke when the user closes or tightens the velcro. It also has to be said that almost the 100% of the piece is blue, what means that the stress are uniformly distributed along the structure of the piece. This is why the stress accumulations are minimal.

- STUDY RESULTS

Resultant Displacement

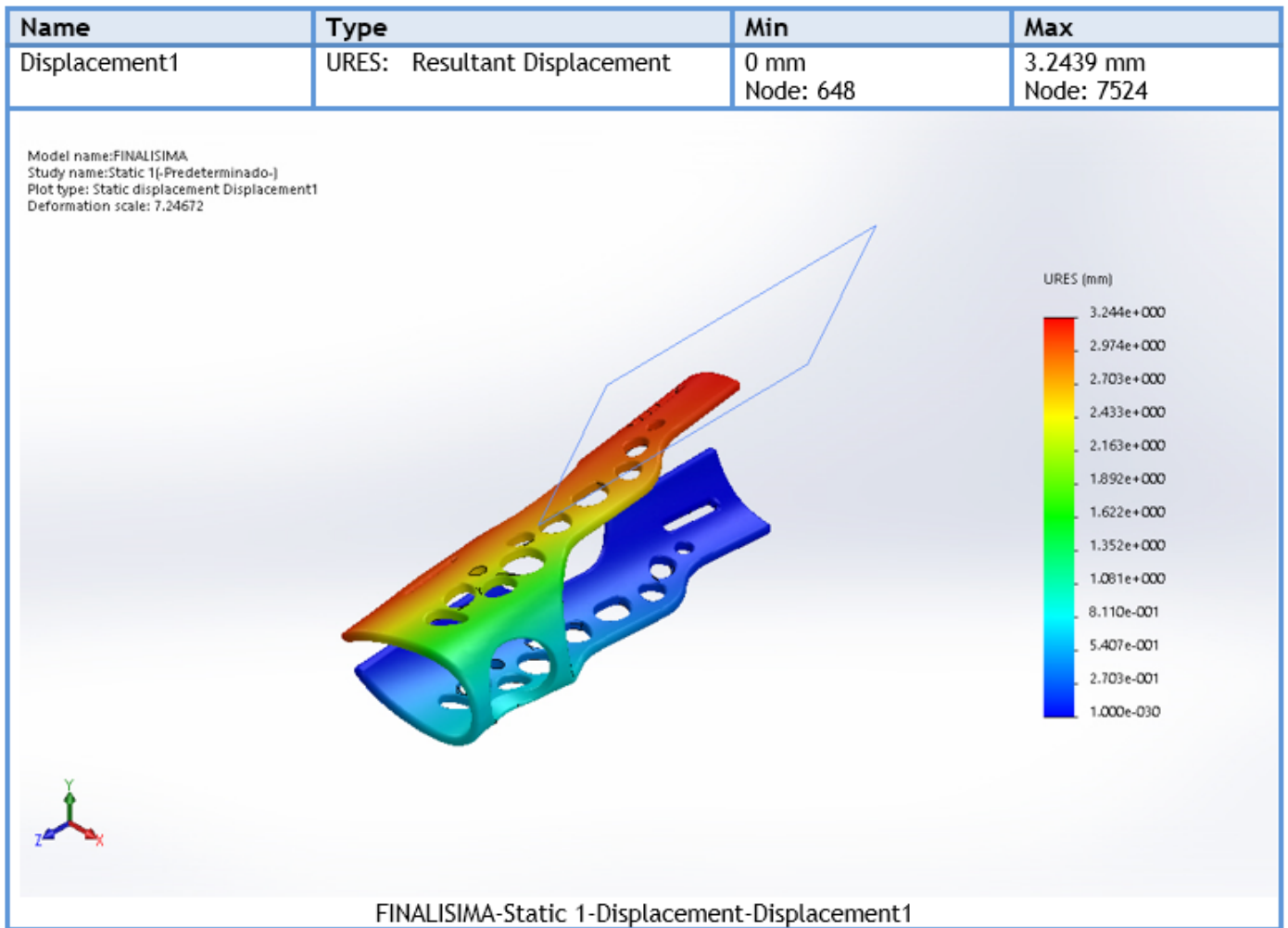

Regarding to the “Displacement” results, it can be said that the piece has suffered a maximum displacement of **(3.244 mm)** which is represented in red on the top face side. In this case, the displacement done is because of the use of Velcro.

- STUDY RESULTS

Equivalent Strain

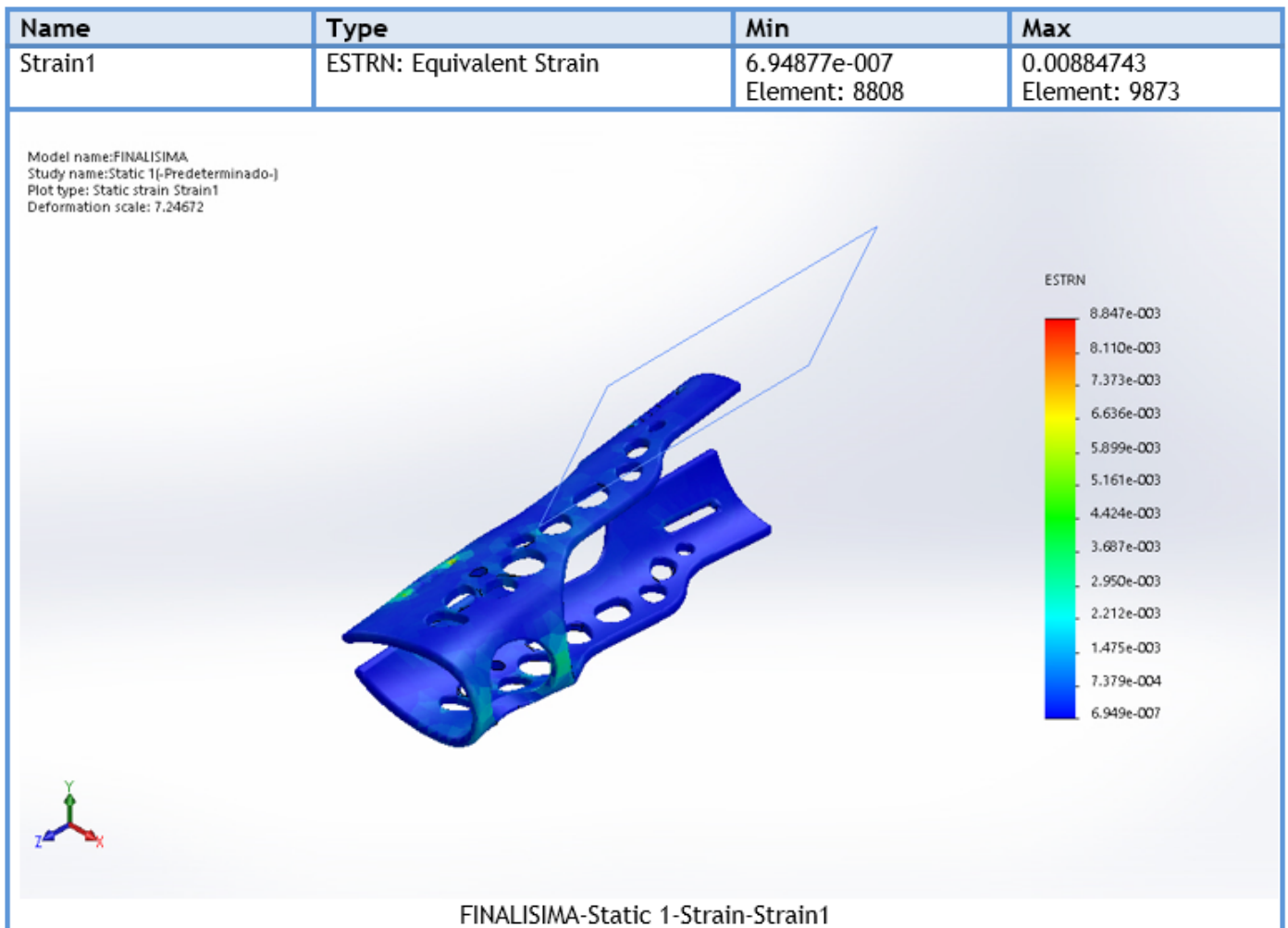

Regarding to “Equivalent Strain”, it is the unitary deformation (epsilon) which is the relationship between the increase in length and length, so it doesn’t have units.

$$\epsilon = \frac{\Delta L}{L}$$

This formula is only for one direction. As there are tensions and deformations in the three directions (x, y, z), the following one has to be used:

Equivalent Von Mises Strain

calculates the equivalent Von Mises strain according to

$$\epsilon_{eq} = \frac{2}{3} \sqrt{\frac{3(e_{xx}^2 + e_{yy}^2 + e_{zz}^2)}{2} + \frac{3(\gamma_{xy}^2 + \gamma_{yz}^2 + \gamma_{zx}^2)}{4}}$$

It is a complex concept that is only practical with computer programs.

RENDERING 10

In this section the renders of the final product are going to be shown. The final color chosen can be observed as well as different perspectives to see deeply the piece details. There have also been several color tests to choose the final one, and at the end a couple of pictures of the application are shown.

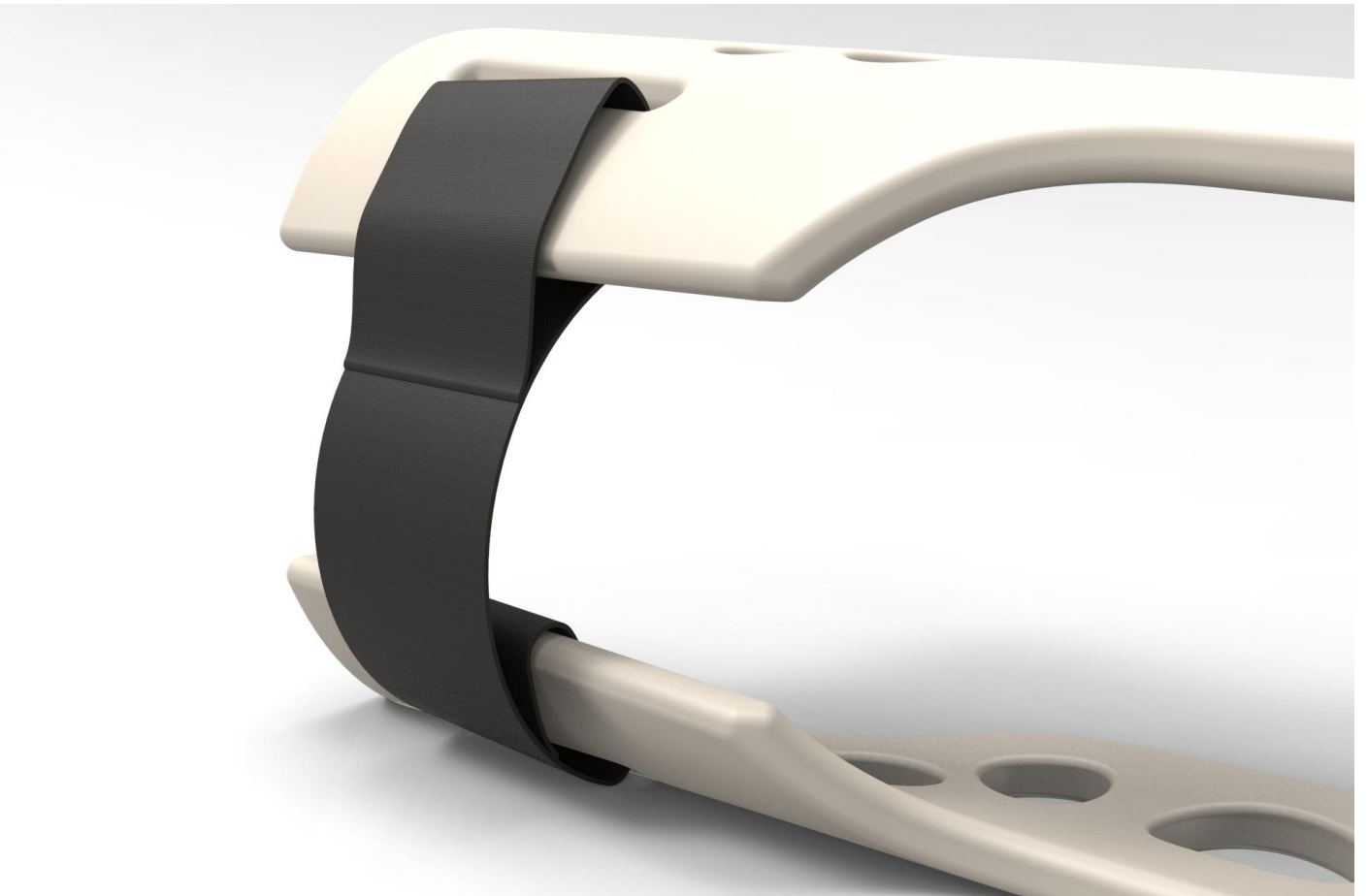

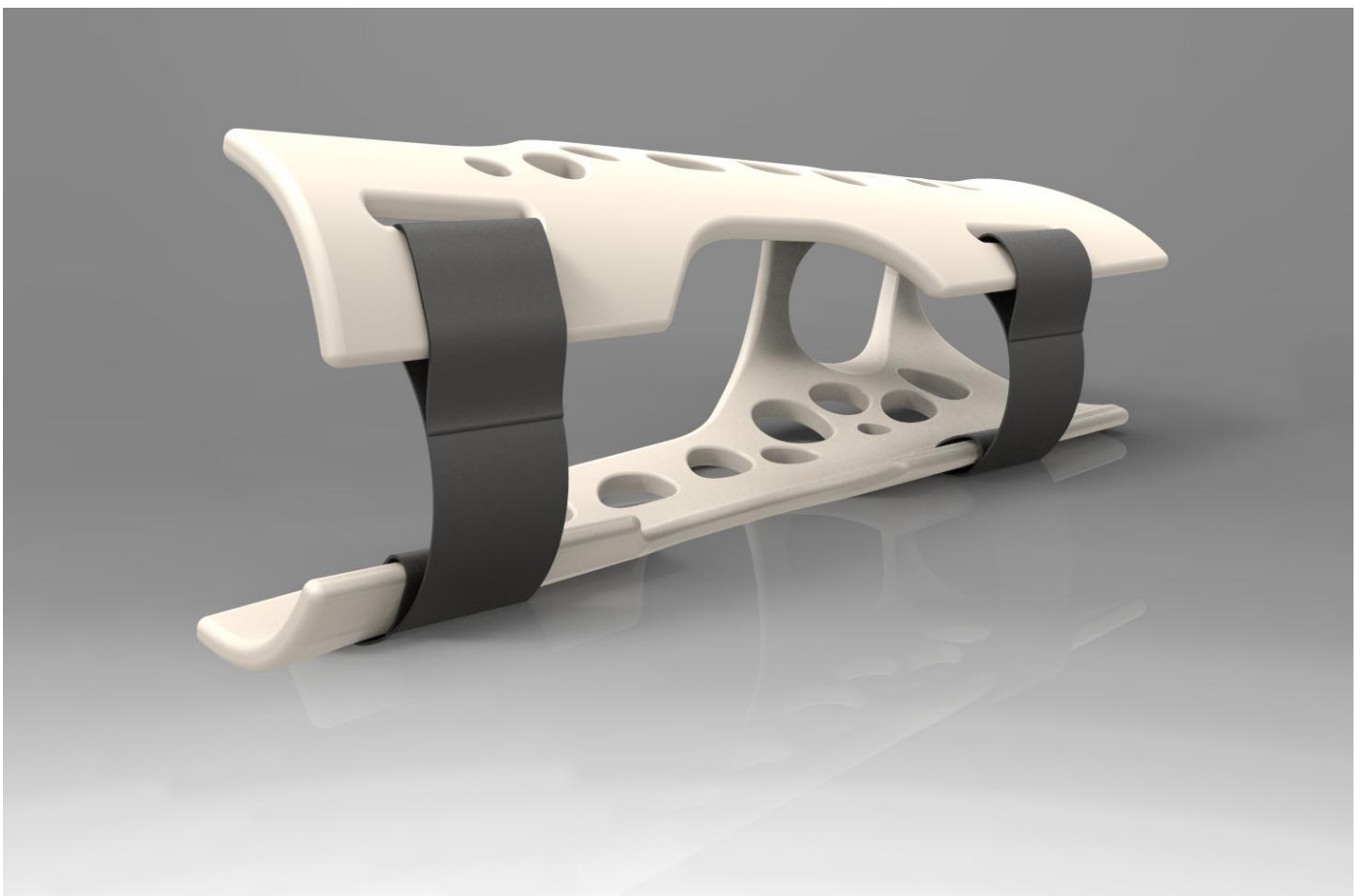
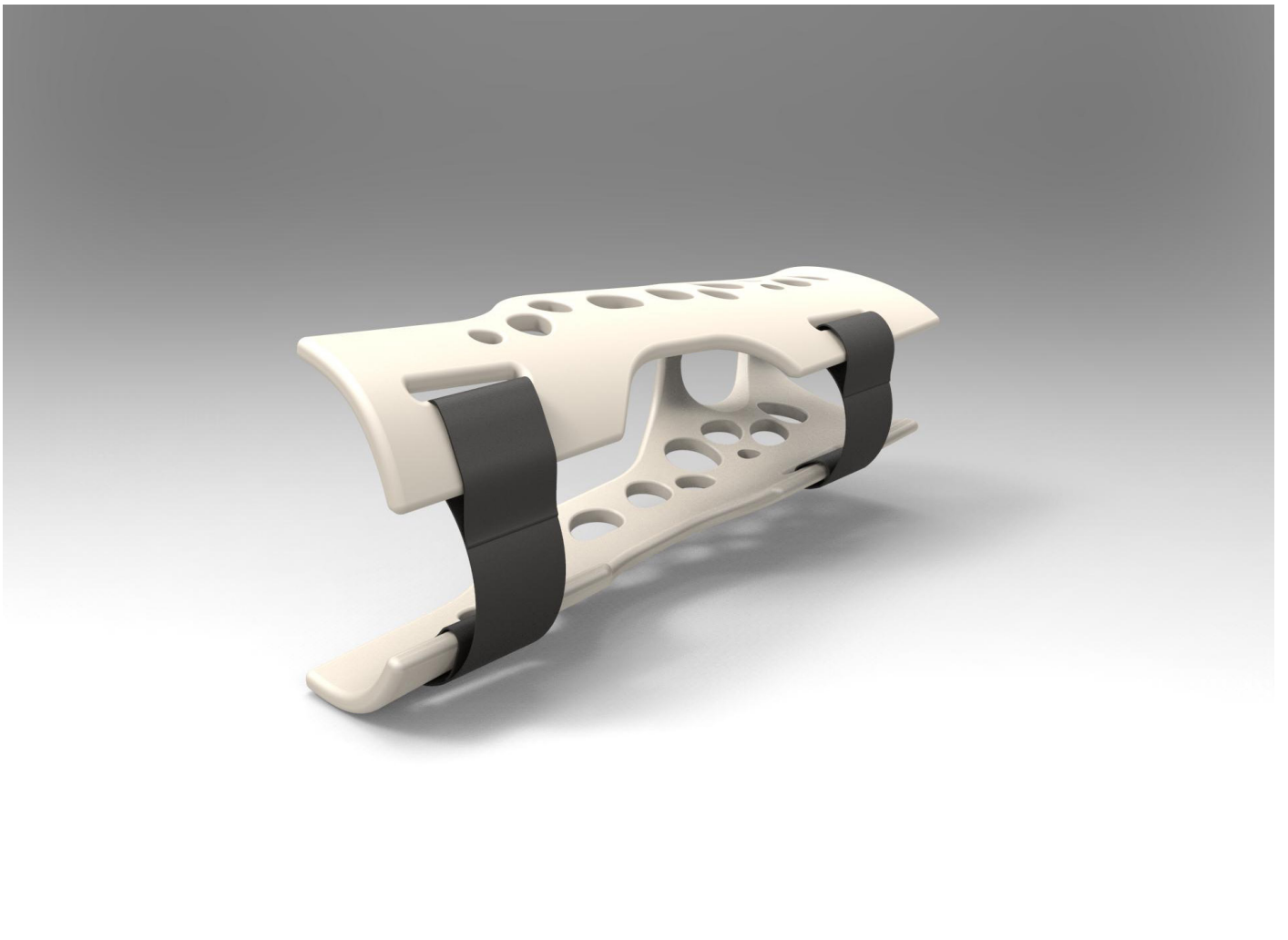

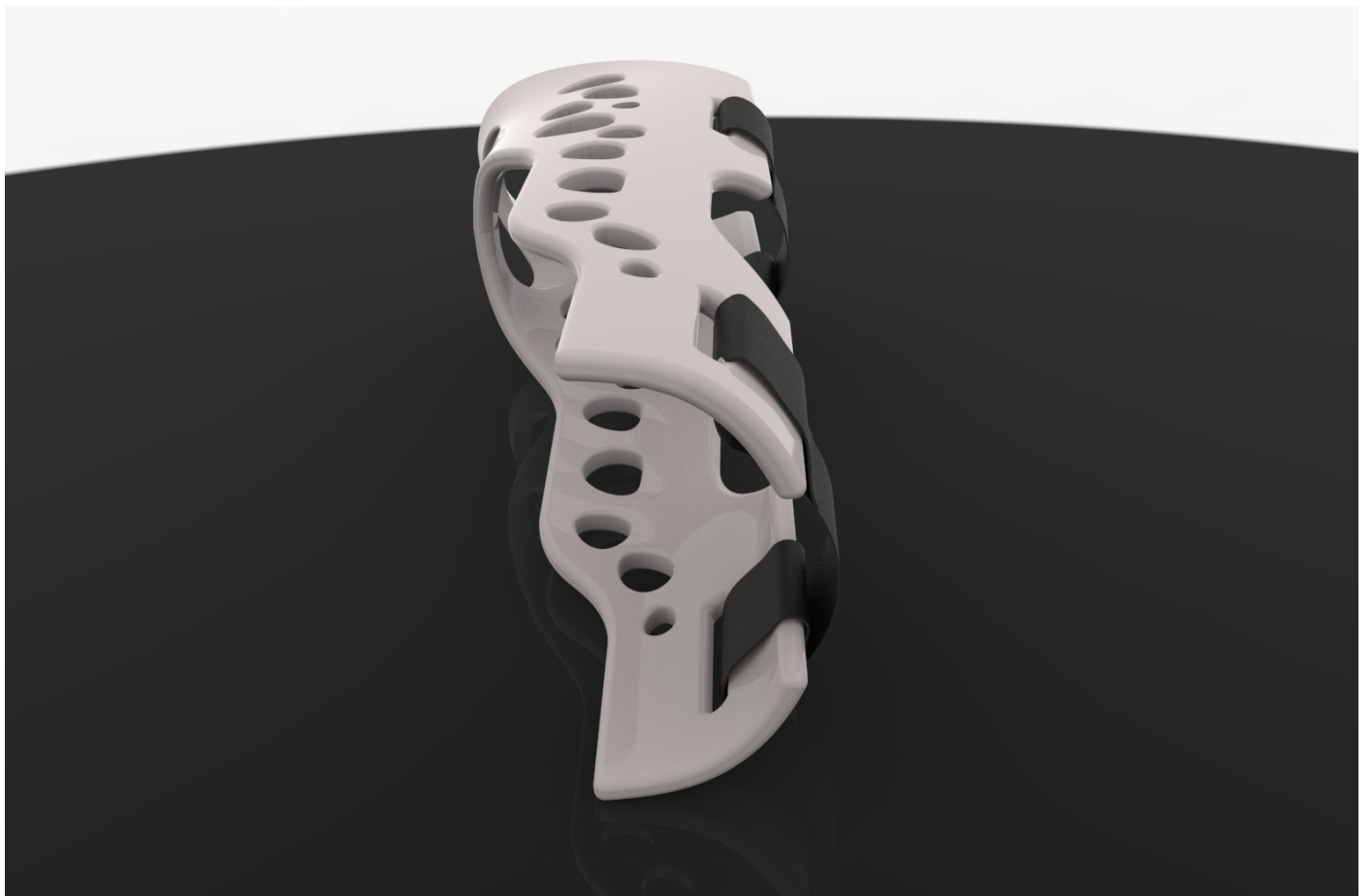
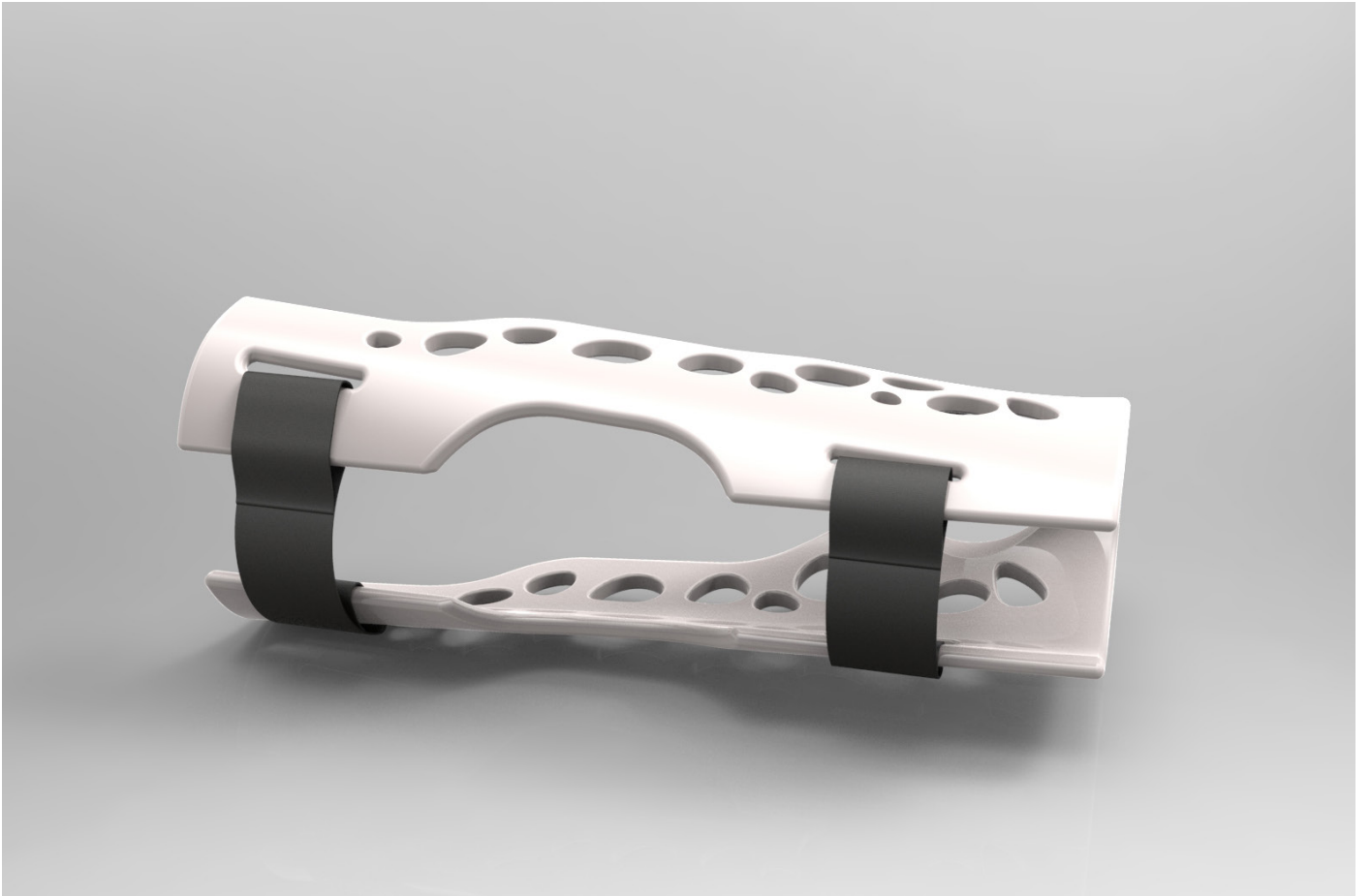

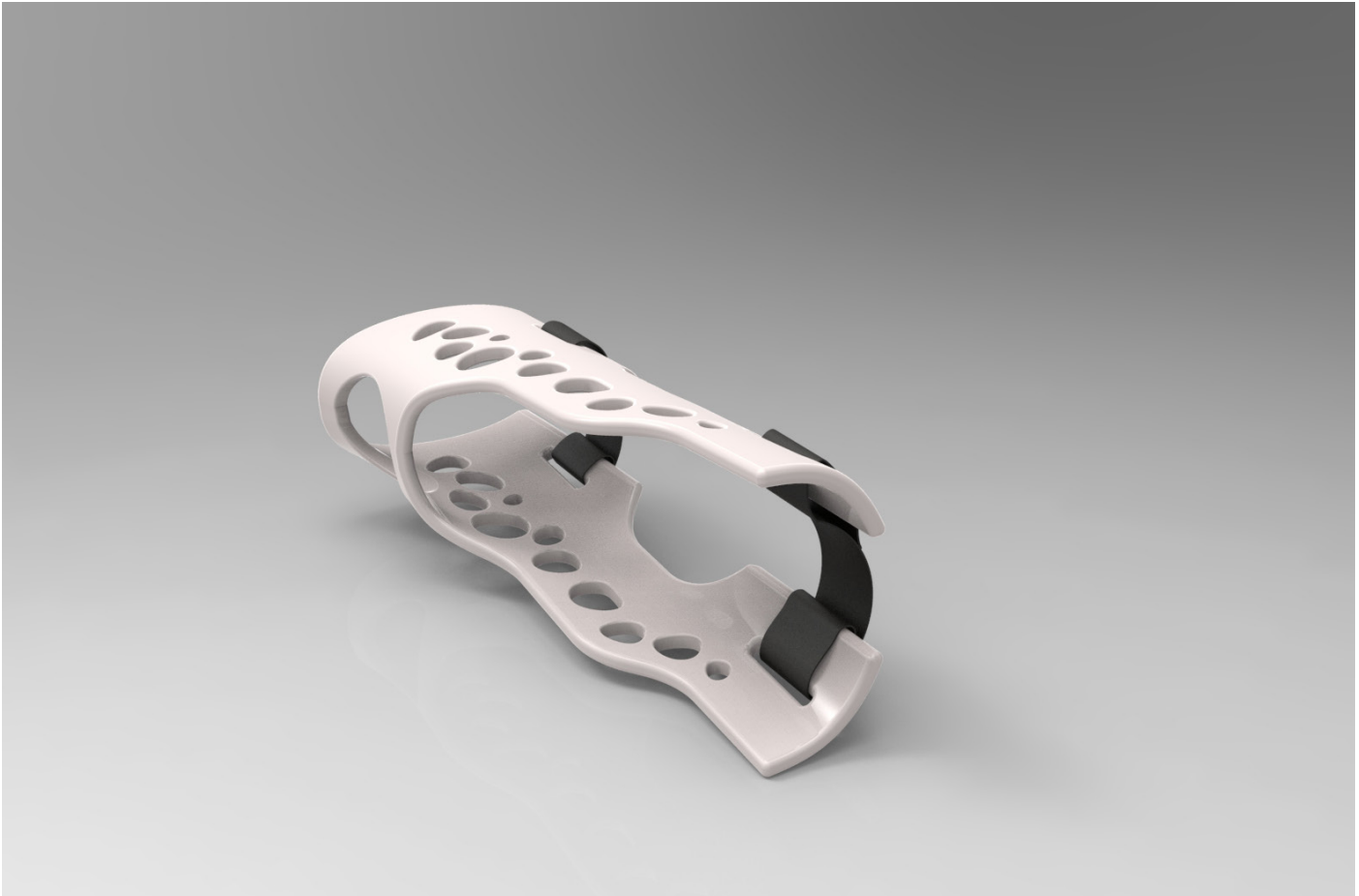

COLOURS AVAILABLE

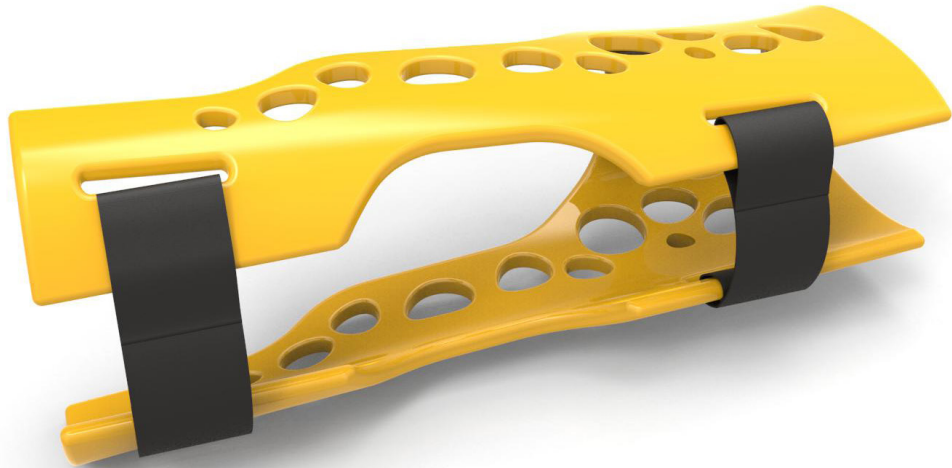

COLOURS AVAILABLE

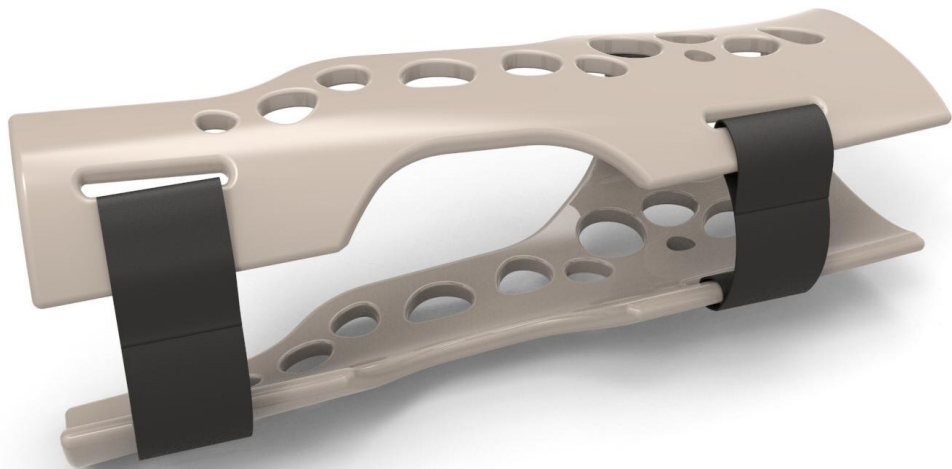
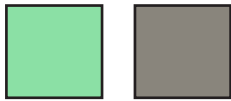
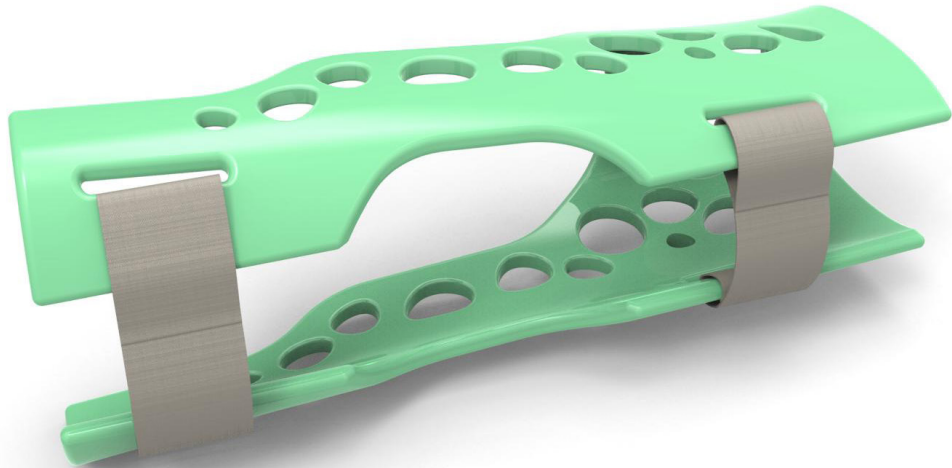

COLOURS AVAILABLE

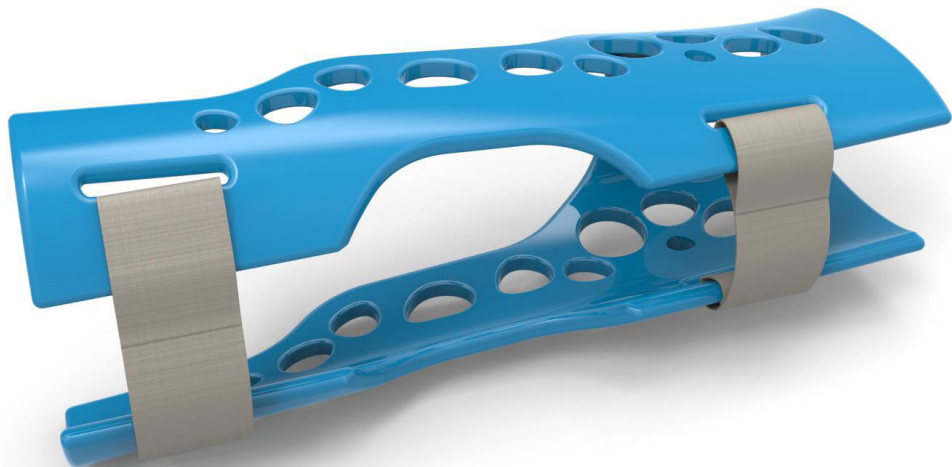

FINAL CONCLUSIONS 1 1

Finally, it can be said that a final product has been designed in accordance with the objectives to be achieved, raised at the beginning of the Project. The requirements and specifications required by the designer were also achieved in order to ensure that the product meets the user needs.

It has been achieved a fairly simple aesthetic, while innovative. This factor will make the product something attractive for sale, and therefore, it will stand out in the market. This aesthetic has been chosen because the fact that it is a product for both genders as for all ages, so it is going to reach a greater number of people.

Regarding to its functionality, the velcro closure system, not only works as a way to close the orthosis, but also, gives the possibility of making the orthosis personalized and adjustable, what is something essential for the first days of recovery, in which tend to appear swellings. Movement is key; An orthosis that can be assembled and disassembled easily requires little effort and can be adapted to all types of spaces and maneuvers.

It also has been reached the production requirement through 3D printing which means reducing costs and being able to create more organic shapes. The material in which the orthosis is made, makes this a lightweight orthosis at the same time resistant. Specifically it is ten times more than the traditional ones. On the other hand, it is a responsible product with the environment, since the main material is recyclable and reusable.

This orthosis design also has ventilation and it can be wet. It is as well more hygienic than a traditional plaster and allows the doctor to perform a better inspection of the limb.

As a conclusion it can be said that an innovative product has been reached and it also is going to help people's life helping them with their daily tasks, without having to forego of such simple things as a simple dip in the pool could be.

FUTURE POSSIBILITIES

12

Hereunder, several improvements related to the product are going to be told to make this a more efficient product.

One of the first proposals is about the thickness of the orthosis structure, as it has been described in the project or as it can be seen in the measurement plane, the orthosis has a thickness of 5 cm. So it was thought that a thickness reduction around 2-3 cm, would improve the mechanical properties of the structure. It would make it lighter, more resistant, and also it would provide a material saving which means a cost reduction of the product. In the following picture, it can be seen three printed pieces made of the same material as the orthosis but with different thickness sizes:

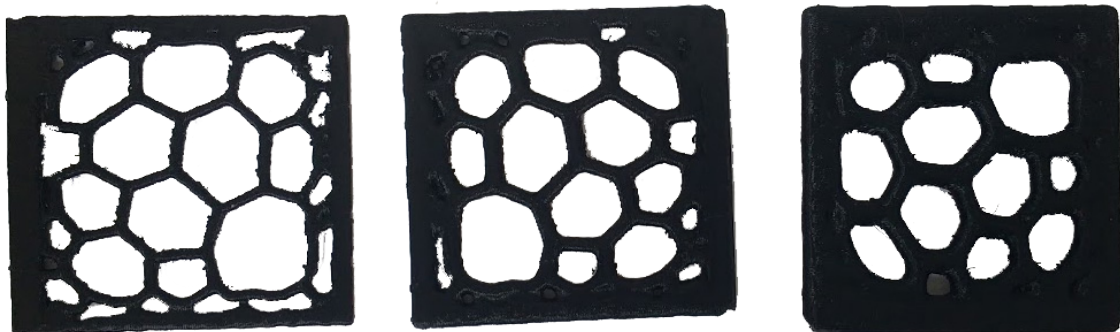

Another proposal to take into account is about the holes that the orthosis has. As it has been said before, these holes are made for working as a ventilation system of it. So it has been thought that a proposal could be increasing the number of hole as their size with the aim of achieving greater ventilation and also a greater hygiene for the piece. And also achieving less use of the material as it happened with the reduction of thickness.

LITERATURE REFERENCES

13

- Webs related to orthosis:

<https://marshallkloene.com/2012/10/31/types-of-orthoses-prostheses/>

<http://www.fior-gentz.de/en/orthotics/orthosis/types-of-orthoses.html>

<https://kuidadores.es/ferula-3d/>

<https://fiixit.es/>

- Webs related to 3D printed:

<https://www.solitium.es/Repro3D/>

<https://latinoamerica.autodesk.com/solutions/3d-printing>

<http://additivemanufacturing.com/2016/06/15/3dp-platform-transforming-ankle-foot-orthosis-afo-with-3d-printing/>

- Softwares:

The program with which the 3D model has been projected is SolidWorks. And the rendering has been done with the KeyShot software. Graphic design software such as Photoshop or Illustrator has also been used to treat images and renders. The project memory has been made using the InDesign program.

- Other references:

<https://www.journals.elsevier.com/additive-manufacturing>

