



UNIVERSITAT  
POLITÈCNICA  
DE VALÈNCIA

CAMPUS D'ALCOI



Uniwersytet Technologiczno-Przyrodniczy  
im. Jana i Jędrzeja Śniadeckich w Bydgoszczy

Polytechnic University of Valencia,  
Alcoy Campus –  
Uniwersytet Technologiczno-Przyrodniczy

Mechanical engineering and Industrial design  
engineering and product development

# STUDY AND DESIGN OF AN UNMANNED AERIAL VEHICLE

Author: Borrell Jornet, Jordi

Tutor: Pérez Fuster, Joaquín  
Graphic and Design Department

Tutor: Szczutkowski, Marek  
Mechanical Department

Bydgoszcz, Poland 11 June 2018



UNIVERSITAT  
POLITÈCNICA  
DE VALÈNCIA

CAMPUS D'ALCOI



Uniwersytet Technologiczno-Przyrodniczy  
Im. Jana i Jędrzeja Śniadeckich w Bydgoszczy

## Abstract:

The objective of this Final Project is the study, design and construction of Unmanned Aerial Vehicles (UAV). A detailed analysis will be provided both internally and externally of the object of study in order to understand its functionality, generalities and applications. In addition, the "Initiation" and "Product and process design" phases will be carried out, describing the manufacturing processes by machinery and industrial plant applied to the current regulations. In this way you can obtain a manufacturing cost with which to make the project viable.

In the "Initiation" phase, the requirements and restrictions of designs according to the market, uses, user, processes, materials, safety regulations and other specific studies will be defined. In the "Product and process design" phase, viable solutions will be obtained specifying shapes and dimensions to accommodate the highest possible load.

If the time and magnitude of the work permit, the "Implementation" and "Operation" phases can be carried out.

In the "Implementation" phase, the intention is to build the prototypes by applying the methods and processes that are carried out in the manufacturing industry of this type of products. And, in the "Operation" phase, the product support documentation will be prepared, such as: the catalog, presentation videos and instruction manual.

If the "Implementation" phase fails for economic and time reasons, a scale prototype can be made in 3D printing.

## Keywords:

Drone, application, design, UAV, mechanical, loads

## Resumen:

El objetivo del presente Trabajo Fin de Grado consiste en el estudio, diseño y construcción de Vehículos Aéreos No Tripulados (VANT). Se proporcionará un análisis detallado tanto interno como externo del objeto de estudio con el fin de entender su funcionalidad, generalidades y aplicaciones. Además, se llevarán a cabo las fases de "Iniciación" y de "Diseño del producto y del proceso" describiendo los procesos de fabricación mediante maquinaria y planta industrial aplicadas a las normativas vigentes. De esta forma se podrá obtener un coste de fabricación con el que viabilizar el proyecto.

En la fase de "Iniciación" se definirán los requisitos y restricciones de los diseños acordes al mercado, usos, usuario, procesos, materiales, normativa de seguridad y otros estudios específicos. En la fase de "Diseño del producto y del proceso" se obtendrán soluciones viables especificando formas y dimensiones para albergar la mayor carga posible.

Si el tiempo y la magnitud de trabajo lo permite, se podrán llevar a cabo las fases de "Implementación" y de "Operación".

En la fase de “Implementación” se pretende construir los prototipos aplicando los métodos y procesos que se realizan en la industria manufacturera de este tipo de productos. Y, en la fase de “Operación” se elaborará la documentación de soporte al producto como son: el catálogo, videos de presentación y manual de instrucciones.

Si la fase de “Implementación” falla por motivos económicos y de tiempo se podrá realizar un prototipo a escala en impresión 3D.

Palabras clave:

Dron, aplicación, diseño, VANT, mecánica, cargas

## Image Index

Image 1: Design concept selection	17
Image 2: Frame	17
Image 3: Motors	18
Image 4: Regulators	18
Image 5: Fly complements	19
Image 6: Propellers	19
Image 7: Battery	19
Image 8: RC transmitter	20
Image 9: First person view	20
Image 10: Camera	21
Image 11: ABS properties	22
Image 12: Nylon Properties	24
Image 13: PP properties	25
Image 14: PE properties	25
Image 15: Drone position with package	29
Image 16: Drone position with package	29
Image 17: Drone position with parachute	30
Image 18: Ansys Aluminium	31
Image 19: Ansys Carbon fiber	32
Image 20: Ansys Polypropilene	32
Image 21: Static preasure	33
Image 22: Total deformation	33
Image 23: Analysis deformation	34
Image 24: Equivalent Stress Von Misses	34
Image 25: Analysis equivalent Stress	35
Image 26: Leg rest position	35
Image 27: Leg tensions with load	36
Image 28: Behavior of the propellers	36
Image 29: Behavior of one propeller	37
Image 30: Wing Support	37
Image 31: Relations Element 1.1.1	39
Image 32: Sub-set Plans 1.1.1	40
Image 33: Relations Element 1.1.2	41

Image 34: Sub-set plans 1.1.2	42
Image 35: Relations Element 1.2	43
Image 36: Sub-set plans 1.2	44
Image 37: Relations Element 2.1	45
Image 38: Sub-set plans 2.1	46
Image 39: Proposed designs	49
Image 40: Disassembly scheme	49
Image 41: Sistematic diagram	50
Image 42: metal catalog	52
Image 43: Screw catalog	52
Image 44: Washer catalog	53
Image 45: Solar cells catalog	53
Image 46: Propeller catalog	54
Image 47: Pivot catalog	55
Image 48: Shear Machine	56
Image 49: Milling machine	57
Image 50: Column Drilling	58
Image 51: Injection machine	59
Image 52: Press machine	60
Image 53: Drill Catalog	61
Image 54: 3D printer	62
Image 55: Seargeant	63
Image 56: Kinpex jaws	63
Image 57: Screw driver	64
Image 58: Bed pressure screw	65
Image 59: Screw box	66
Image 60: Propeller Box	66
Image 61: Washer Box	67
Image 62: Pellets Box	67
Image 63: Naylon filaments	68
Image 64: Carbon Fiber filaments	68
Image 65: Activity Planning	76
Image 66: Activity diagram	77
Image 67: Activity Plan with times	78

## Table Index

Table 1: Material Properties	31
Table 2: Pre-dimensioning	38
Table 3: Element 1.1.1 (Lower Housing)	39
Table 4: Normalized Elements 1.1.1 (Lower Housing)	39
Table 5: Element 1.1.2 (Propeller)	41
Table 6: Normalized Elements 1.1.2	41
Table 7: Element 1.2 (Legs)	43
Table 8: Normaliced Elements 1.2	43
Table 9: Element 2.1 (Upper housing)	45
Table 10: Normaliced Elemenst 2.1	45
Table 11: Lower Housing Injection	69
Table 12: Aluminion Rounding	70
Table 13: Aluminium Holey	70
Table 14: Aluminium curved	71
Table 15: Upper Housing Injection	71
Table 16: Lower Housing Injection	75
Table 17: Activity Table	77
Table 18: Initial Pert	78
Table 19: Pert with Adjustment	79
Table 20: Descomposition of activities	79

## Graph Index

Graph 1: Age	11
Graph 2: Gender	11
Graph 3: Speciality	12
Graph 4: Frequency	12
Graph 5: purchases	12
Graph 6: Time	13
Graph 7: Seller time	13
Graph 8: Sending	13
Graph 9: Additive	14
Graph 10: Thought	14
Graph 11: Danger	14

Graph 12: Security	15
Graph 13: Purchase of drone	15
Graph 14: Possibility	15
Graph 15: Aspect	16



## INTRODUCTION

Remotely Piloted Aircraft Systems have gained great significance due to their economic potential and practical applicability. These systems allow the operation of an aircraft without a pilot on board, and include the ground control station, the communications link and the aircraft. Current regulations restrict the operation of these aircraft to segregated airspace, so multiple studies and initiatives are being conducted to achieve their integration into shared or non-segregated airspace, to ensure their viability. Non segregated airspace has a clearly defined structure, procedures and information services which are known as Air Traffic Management. The main function of Air Traffic Management systems is to those services required for the safe operation of aircraft into shared airspace, so that the interaction of these new systems is paramount for the future development.

The possibility of transmitting images or data in real time to a base or terrestrial devices, or the increase of the load that can transfer them, has meant a great advance, since it has allowed incorporating a greater number of sensors that allow controlling agents of the flight, such as speedometers, gyroscopes or altimeters, or external agents such as gas concentrations, or the implementation of the LIDAR system, among others. Waking up the interest of a new civil industry dedicated exclusively to the manufacture and maintenance of these unmanned vehicles. Therefore, drones are used in multiple applications depending on the number of sensors they have incorporated. The simplest and cheapest aircraft have image stabilizers and optical cameras, to capture or record any image that is relevant, these are widely used in industries related to entertainment, while the most complex have countless sensors, cameras and communication systems, whose purpose is to perform a sweep of the environment that surrounds them, detecting and attacking any type of danger that may occur, these aircraft are widely used in the military field.

This project aims to show from 0 the design, operation and construction of a drone capable of being used for the taking of moving aerial images and the transport of heavy elements.

Among the main objectives, you can find:

- Normative: industrial ship, machine, object...
- Market study about the object
- Object design (SolidWorks)
  - Analysis of materials, forces and mechanical resistance of the object (Ansys)
  - Render (Keyshot)
- Design the plans of an industrial plant (Autocad)
  - Electrical parts, wiring, switches, emergency lights, fire extinguishers...

- Route of operators for the construction of the object
- Distribution of machinery in the industrial ship

-Production times, processes, budget and machinery controls

-3D printing (Slic3r, Netfabb)

## **DESCRIPTIVE MEMORY**

### **1.1 BACKGROUND**

The starting conditions are:

- The innovative design of a drone capable of carrying weight for use in messaging

- Mechanical elements and forces that can intervene.

- Normative of materials, machinery and plans

### **1.2 OBJECT OF STUDY**

The purpose of this study is to describe the preliminary design and mechanical process by presenting the elements that will intervene in the project.

### **1.3 PROJECT JUSTIFICATION**

Drones are an emerging technology that few people know. The purpose is to focus this novelty for the improvement of society, looking for different solutions and applications through the improvement of these objects.

### **1.4 MARKET STUDY**

The object of market study is a drone.<sup>1</sup>

Companies are looking for new developments in this emerging field in terms of design and applications, so we will seek to find a quality solution in terms of the construction of the pieces that will compose the drone, always trying to enter a market gap where the differentiation is the main priority.

Magnitude and size of market:

Within the emerging market of this type of products we find two clearly differentiated sectors. On the one hand, there is the final consumer who uses the product for enjoyment through the recording images and control.

On the other hand, the most important courier companies want to be able to reach their consumers as soon as possible. In this way they look for legal means that allow them to use this type of objects for their benefit.

The drones are organized according to prices from the highest quality. Depending on the consumer's economy, the purchase range will increase or decrease the price. In the market, there are all kinds of price, so it focuses on a high quality area for the proposed drone. This happens because the consumer can acquire this product in the same way as companies.

The companies will obtain a quality product that satisfies their needs of transport of messaging service up to a maximum of 10 Kg and the consumers, in addition to being able to obtain this service; will also be able to use it for the recording of aerial images.

Then, the different results of the market study are shown in order to understand the main needs of consumers and their habits. In this way, it is possible to focus on a market segment to introduce the product.

The market study consists of a business initiative in order to get an idea about the commercial viability of an economic activity.

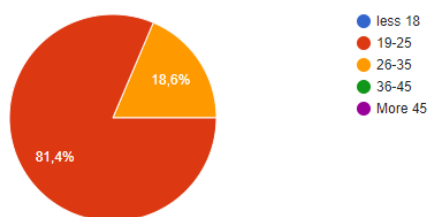
That is why it is intended to know by hand what are the thoughts, concerns and characteristics that society values in this type of objects.

In addition, it is important to know the buyer model by age, gender, range of money to be able to satisfy the most in-depth needs of final consumers.

A survey of 50 anonymous people has been carried out to Spanish people. The survey was done in March between 13<sup>th</sup> – 20<sup>th</sup> and passed on the internet. UPV has a platform for do surveys and people of all university can do it. This is why 50 people decide to fill it and know more about drones.

What age range do you belong to?

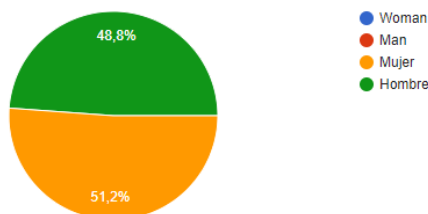
43 respuestas



Graph 1: Age

Gender

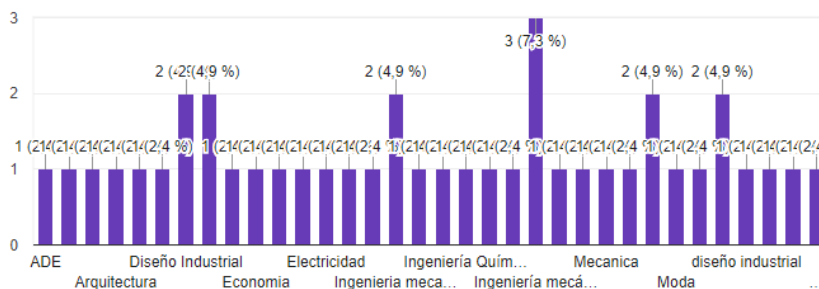
43 respuestas



Graph 2: Gender

### Especiality

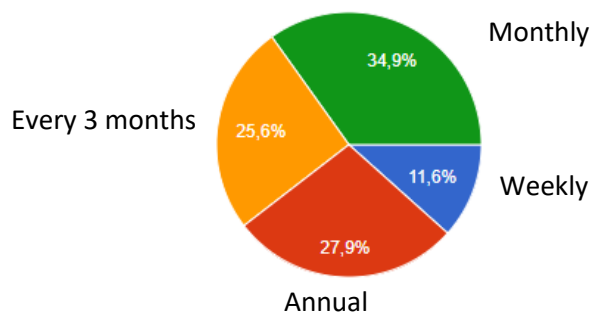
41 respuestas



Graph 3: Speciality

### What is your purchase frequency online?

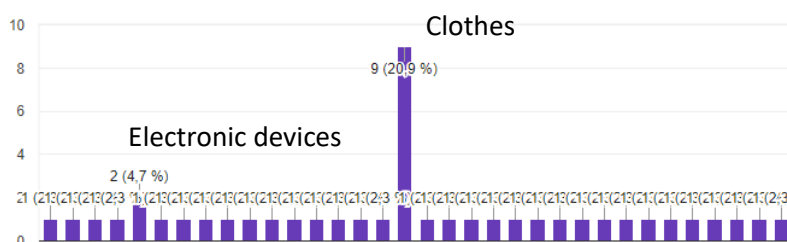
43 respuestas



Graph 4: Frequency

### What do you usually buy online?

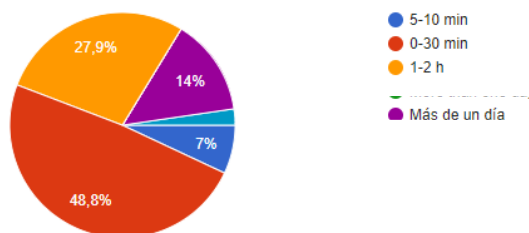
43 respuestas



Graph 5: purchases

### How much time do you spend to make the purchase?

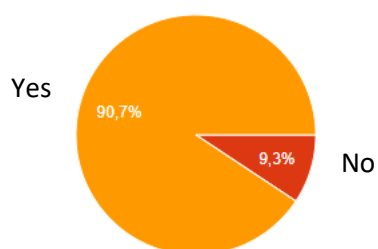
43 respuestas



Graph 6: time

### Do you consider important the time from when the seller sends the product until you receive it?

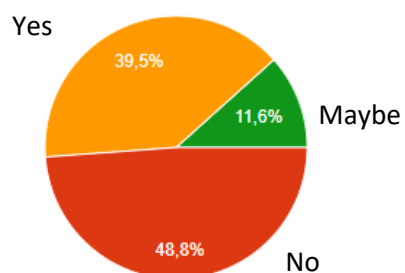
43 respuestas



Graph 7: Seller time

### If Amazon could send your order faster using a drone, would you be willing to pay an extra shipping fee?

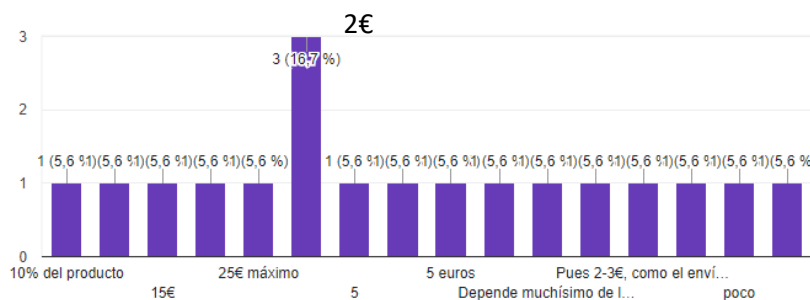
43 respuestas



Graph 8: Sending

### If you chose yes, specify how much

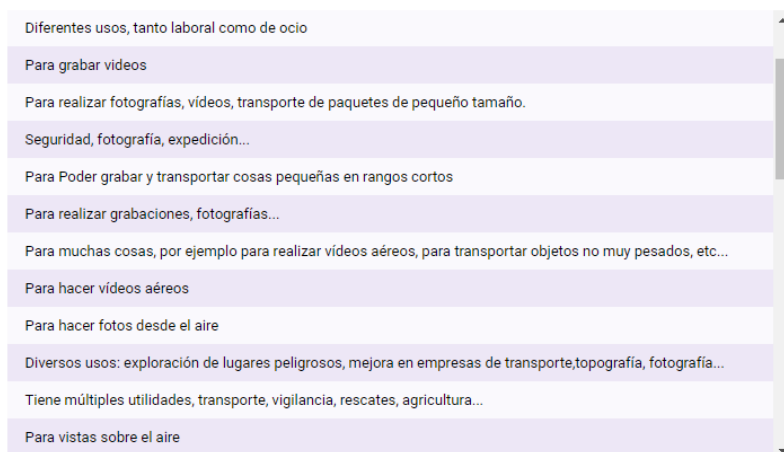
18 respuestas



Graph 9: Additive

### What do you think a drone is for?

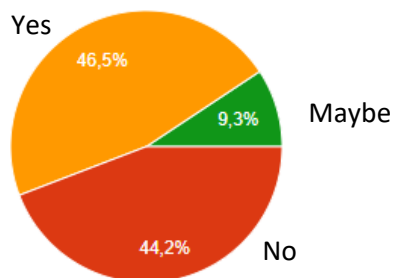
43 respuestas



Graph 10: Thought

### Do you consider a drone dangerous?

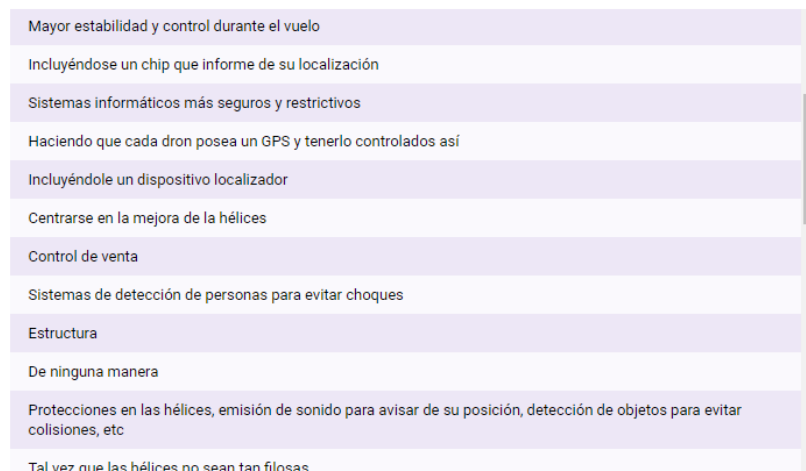
43 respuestas



Graph 11: Danger

### How do you think it could improve the safety of drones?

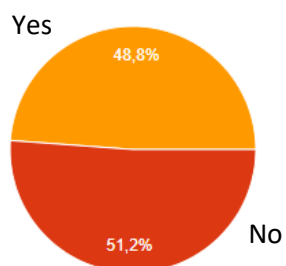
43 respuestas



Graph 12: Security

### Have you ever thought about buying one?

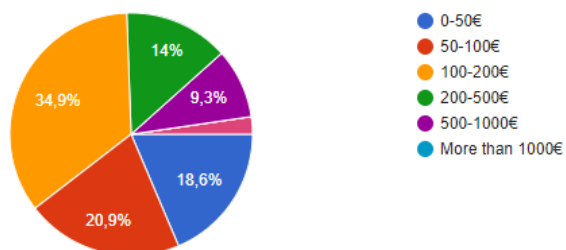
43 respuestas



Graph 13: purchase of drone

### If you had the possibility of buying one in which strip of money would you move?

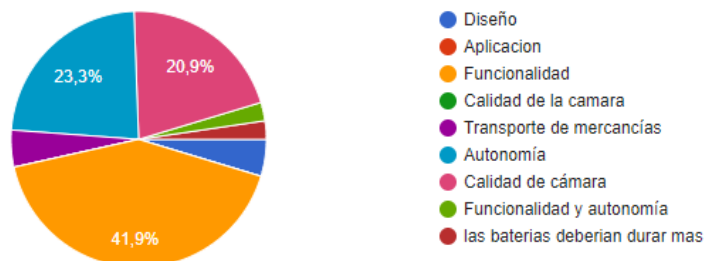
43 respuestas



Graph 14: Possibility

## Mark the most important aspect

43 respuestas



Graph 15: Aspect

### Conclusion:

Most people interested in drones are between 19 and 25 years old and have baccalaureate and university degrees.

The highest percentage of online purchases is monthly, highlighting the purchase of clothes and electronic devices, and spending an average of 30 minutes during the online purchase.

Almost 100% of the respondents believe that the shipping time of the online seller is important, so that a part of them would pay a supplement to receive faster products.

Regarding drones, many people agree that drones are used to record, transport objects, have fun and fly over difficult areas.

In turn, half of them think that a drone is dangerous and that they should improve certain parameters especially in autonomy, control and propellers.

There is a diversity in the range of opinions on how much to pay for a drone (€ 100-500) and on the most important aspect of a drone: Functionality and Autonomy.



## 1.5 DESIGN CONCEPT SELECTION

For this case, it will be based on a conceptual design that will penetrate directly into the appropriate segment of the market. If we wanted to obtain different solutions, we would use the Weighted Technical Value method.

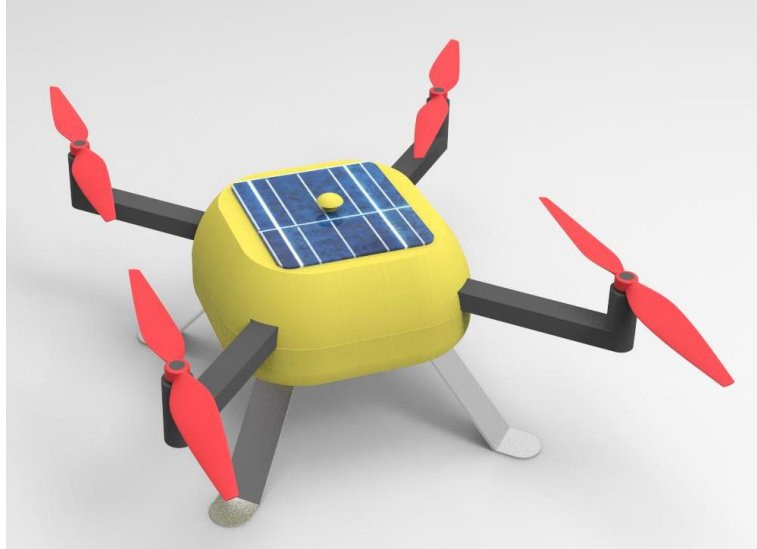


Image 1: Design concept selection

## 1.6 ANALYSIS OF INTERNAL ELEMENTS [2](#)

### -Frame or Chassis

It is the skeleton of the multirotor. It is the structure that gives it shape and where all the components of it must be housed for its correct operation: Motors, electronics, batteries, etc.

The materials used for the construction of the chassis, are closely related to the benefits to which the drone is destined (aluminium, carbon fibre, fiberglass, Kevlar, etc.) and closely related to the price.



Image 2: Frame

## -Motors

They are the fundamental components to keep the multirotor in the air. The most common are the Brushless type electric that do not use brushes to make the change of polarity in the rotor. They stand out for the weight / power ratio.



Image 3: Motors

## -Regulators

The speed regulators or ESC (Electronic Speed Control) are responsible for electronically providing the necessary revolutions to each motor / propeller individually at a given time to perform different movements (elevations, rotations, translations, acrobatics, etc.).



Image 4: Regulators

## -Flight Controller or Control Unit

It is the brain of all Drone. Controls everything that happens in the Drone and is where they are connected almost all components of the Drone (regulators, sensors, etc).

Most common sensors:

Gyroscope. - Allows to have the drone level.

Accelerometer. - Measures variations of acceleration or speed.

Barometer. - Measures height variations, also called altimeters.

Compass. - Measure the orientation of the drone.

GPS. - Measure and place the drone in geographic coordinates. (GPS satellites network)



Image 5: Fly complements

### -Propellers

They are manufactured in different sizes and materials, composed of nylon, carbon fibre, etc. They are responsible for, changing enough thrust for each pair of motors turning in the opposite direction.

Each helix is determined by two digits (50/30) where the first digit represents the length of the helix and the second digit the pitch or helix pitch. Higher length of the thruster causes higher thrust and also the higher current count. So you have to use the propellers appropriate to any model.



Image 6: Propellers

### -LIPO Batteries (Lithium Polymers)

Provide the necessary energy to operate the Drone. They are very heavy components so it is essential that they are able to have a good weight / capacity ratio to maximize the autonomy of the Drone's flight. The lithium polymer is due to its energy density, its low weight and its high discharge rate which is ideal for agile manoeuvres like those of a multicopter.



Image 7: Battery

## -RC transmitter

The Issuer is the remote control of the drone and the one that establishes the communication between the pilot and the Drone in a bidirectional way: the pilot gives flight instructions to the drone and the drone gives relevant information about its status to the pilot, such as the state of the battery or your GPS position.

·Types of wireless communications.

A.M, FM, 2.4 Ghz. The 2.4 Ghz being the most frequent in aeromodelling because it ends with interference problems.

Wi-Fi: Bluetooth Used in Drones equipped with Wi-Fi or Bluetooth control for Tablet or Smartphone.

·Channels of the station:

Each of the channels manages a function of the Drone by electronic servos. Examples of channels are: the power channel, elevation channel, rudder channel, etc.

·Screen:

It shows all the relevant information about the status of the drone to the pilot: Battery consumption, position coordinates, status and quality of the signal, FPV, etc.



Image 8: RC transmitter

## -FPV (First Person View)

The FPV is a system of transmission and reception of the video captured by the camera of the Drone, in real time. This way the pilot can see what the drone is "seeing". It is one of the most mentioned characteristics when choosing a drone or another.



Image 9: First person view

## -Camera and Stabilizer

The structure of the drone have a camera installed (many are included) that depending on the power of the drone can be a small size GoPro to a professional type. The camera is installed in a stabilizer called Gimbal to prevent the movements of the multicopter flight from affecting the shots. These gimbal absorb the vibration of the motors and automatically correct the inclination of the camera so that it is always at the same angle with the ground. Depending on the quality of the station we can have a channel to move the Gimbal and position the camera.



Image 10: Camera

## 1.7 TECHNIC AND PHYSIC VIABILITY - MATERIALS

For the viability of this project, it is intended to fix the material to be used and its geometry.

In this way, you can obtain two viable ways to build the product.

- 3d print
- Plastic Injection

### 1.7.1 3D PRINT [3](#)

We will analyze the materials separately to see their conditions and characteristics, whether they are resistant to breakage or contamination.

ABS: It is a thermoplastic polymer, very impact resistant plastic, It is often called engineering plastic because its processing and processing is somewhat more complex than in common plastics. ABS is an example of a composite of materials that, with the union of their properties, seeks to be an alternative to the development of new materials.

The resistance of ABS to extreme temperatures, especially when they are below zero makes it an especially interesting material for cold environments, staying unchanged where others become brittle.

In addition, ABS absorbs little water and is easily coated with metal layers as it is very receptive to metal baths.

The ABS [4](#) is opaque and can be dark or ivory. It can be pigmented in most colors obtaining a good finish and is not toxic.

The ABS is more indicated when looking for strength in the result or when what is going to print will be exposed to extreme temperatures. It is available in a

wider range of colors, especially because of its good tolerance to pigmentation itself, although its price is higher than the PLA.

General properties			
Density	(i)	1,01e3 - 1,21e3	kg/m <sup>3</sup>
Price	(i)	* 2,15 - 2,54	EUR/kg
Mechanical properties			
Young's modulus	(i)	1,1 - 2,9	GPa
Yield strength (elastic limit)	(i)	18,5 - 51	MPa
Tensile strength	(i)	27,6 - 55,2	MPa
Elongation	(i)	1,5 - 100	% strain
Hardness - Vickers	(i)	5,6 - 15,3	HV
Fatigue strength at 10 <sup>7</sup> cycles	(i)	11 - 22,1	MPa
Fracture toughness	(i)	1,19 - 4,29	MPa.m <sup>0.5</sup>
Thermal properties			
Maximum service temperature	(i)	61,9 - 76,9	°C
Thermal conductor or insulator?	(i)	Good insulator	
Thermal conductivity	(i)	0,188 - 0,335	W/m.°C
Specific heat capacity	(i)	1,39e3 - 1,92e3	J/kg.°C
Thermal expansion coefficient	(i)	84,6 - 234	µstrain/°C
Electrical properties			
Electrical conductor or insulator?	(i)	Good insulator	
Optical properties			
Transparency	(i)	Opaque	
Eco properties			
Embodied energy, primary production	(i)	* 90,3 - 99,9	MJ/kg
CO2 footprint, primary production	(i)	* 3,64 - 4,03	kg/kg
Recycle	(i)	✓	
Recycle mark	(i)		



Image 11: ABS properties

PLA: It is a thermoplastic polymer, permanent, biodegradable and odourless polymer.

It is clear and bright like polystyrene (used to make batteries and toys). Resistant to moisture and grease. It has taste and odor barrier characteristics similar to polyethylene terephthalate plastic, used for non-alcoholic beverages and for other non-food products.

The tensile strength and modulus of elasticity of PLA is also comparable to polyethylene. But it is more hydrophilic than polyethylene, it has a lower density. It is stable to U.V. light, resulting in fabrics that do not fade. Its flammability is too low.

The PLA can be formulated to be rigid or flexible and can be copolymerized with other materials. The PLA can be made with different mechanical characteristics depending on the manufacturing process followed.



### Propiedades generales

Densidad	(i)	1,24e3	kg/m <sup>3</sup>
Precio	(i)	* 2,34 - 3,2	EUR/kg
Fecha de primer uso ("-" significa AC)	(i)	1993	

### Propiedades mecánicas

Modulo de Young	(i)	3,3 - 3,6	GPa
Modulo a cortante	(i)	* 1,2 - 1,29	GPa
Módulo en volumen	(i)	* 5,7 - 6,3	GPa
Coefficiente de Poisson	(i)	* 0,38 - 0,4	
Límite elástico	(i)	55 - 72	MPa
Resistencia a tracción	(i)	47 - 70	MPa
Resistencia a compresión	(i)	66 - 86	MPa
Elongación	(i)	3 - 6	% strain
Dureza-Vickers	(i)	* 17 - 22	HV
Resistencia a fatiga para 10 <sup>7</sup> ciclos	(i)	* 22,2 - 27,7	MPa
Tenacidad a fractura	(i)	* 3 - 5	MPa.m <sup>0.5</sup>
Coefficiente de pérdida mecánica (tan delta)	(i)	0,06 - 0,09	

### Propiedades térmicas

Punto de fusión	(i)	145 - 177	°C
Temperatura de vitrificación	(i)	52 - 60	°C
Máxima temperatura en servicio	(i)	* 45 - 55	°C
Mínima temperatura en servicio	(i)	-20 - -10	°C
¿Conductor térmico o aislante?	(i)	Buen aislante	

### Reciclado del material: energía, CO2 y fracción reciclable

Reciclaje	(i)	✓	
Contenido en energía, reciclado	(i)	* 34,8 - 38,5	MJ/kg
Huella de CO2, reciclado	(i)	* 2,74 - 3,02	kg/kg
Fracción reciclable en suministro habitual	(i)	* 0,5 - 1	%
Reciclado inferior	(i)	✓	
Combustión para recuperar energía	(i)	✓	
Calor neto de combustión	(i)	* 18,8 - 19,8	MJ/kg
Combustión CO2	(i)	* 1,79 - 1,88	kg/kg
Vertedero	(i)	✓	
Biodegradable	(i)	✓	
Ratio de toxicidad	(i)	No tóxico	
Fuente renovable	(i)	✓	

**NYLON:** Polyamides, or also known as nylon, (PA) are semicrystalline polymers. There are two types. Polyamides structured from a single starting material and structured polyamides from 2 starting materials. The polyamides possess a magnificent picture of mechanical properties, a very high tenacity and excellent characteristics of sliding and resistance to wear. Its properties vary from hard and tenacious PA 66 to soft and flexible PA 12. Depending on the type of material, polyamides absorb different amounts of moisture, which are influenced by mechanical characteristics and dimensional accuracy.

In the manufacture of semi-finished products, extrusion and casting are distinguished. By means of the casting process it is possible to manufacture semi-finished polyamide products of larger dimensions and a higher degree of crystallization (greater mechanical resistance), which contain less internal stresses. On the contrary, the extrusion method allows to manufacture with lower costs.

Medium-high mechanical resistance, hardness, rigidity and toughness, a high mechanical damping capacity, good resistance to fatigue, excellent wear resistance, good sliding properties, in most cases, high moisture absorption, in most cases, reduced dimensional stability.

#### Propiedades generales

Densidad	①	1,12e3	-	1,14e3	kg/m <sup>3</sup>
Precio	①	* 2,31	-	2,51	EUR/kg

#### Propiedades mecánicas

Modulo de Young	①	2,62	-	3,2	GPa
Límite elástico	①	50	-	94,8	MPa
Resistencia a tracción	①	90	-	165	MPa
Elongación	①	30	-	100	% strain
Dureza-Vickers	①	25,8	-	28,4	HV
Resistencia a fatiga para 10 <sup>7</sup> ciclos	①	* 36	-	66	MPa
Tenacidad a fractura	①	* 2,22	-	5,62	MPa.m <sup>0.5</sup>

#### Propiedades térmicas

Punto de fusión	①	210	-	220	°C
Máxima temperatura en servicio	①	110	-	140	°C
¿Conductor térmico o aislante?	①	Buen aislante			
Conductividad térmica	①	0,233	-	0,253	W/m.°C
Calor específico	①	* 1,6e3	-	1,66e3	J/kg.°C
Coefficiente de expansión térmica	①	144	-	149	μstrain/°C

#### Propiedades eléctricas

¿Conductor eléctrico o aislante?	①	Buen aislante			
----------------------------------	---	---------------	--	--	--

#### Ecopropiedades

Contenido en energía, producción primaria	①	* 115	-	127	MJ/kg
Huella de CO <sub>2</sub> , producción primaria	①	* 7,58	-	8,38	kg/kg
Reciclaje	①	✓			
Marca de reciclaje	①				



Image 12: Nylon Properties

Conclusion: The main properties that we look for in the prototype is a high resistance to impacts and resistance to high temperatures that can take the electrical circuit so we opted for Nylon because it can absorb impacts and be rigid enough.

### 1.7.2 MATERIAL FOR INJECTION PROCESS

For the design and development of the drone, it is necessary to analyze materials for serial production, so different materials will be analyzed to see which would be ideal if we want to manufacture the drone by injection. The most used materials in the injection process are Polyethylene and Polypropylene, due to their fluidity and melting temperature, these two materials are suitable for the injection process.

Polypropylene (PP)<sup>5</sup>: provides precise control of its impact resistance. In its natural state it is a flammable material and degrades with sunlight, but through chemical processes we achieve stability and resistance to temperature and ultraviolet rays. Once this material is used, it can be reused, converting it into pellets and processing it again. It can be processed several times without losing its qualities so by combining unprocessed raw material with a percentage of the processed material we will reduce the CO<sub>2</sub> emissions that are produced when manufacturing it.



### Propiedades generales

Densidad	(i)	890	-	910	kg/m <sup>3</sup>
Precio	(i)	* 1,52	-	1,58	EUR/kg

### Propiedades mecánicas

Modulo de Young	(i)	0,896	-	1,55	GPa
Límite elástico	(i)	20,7	-	37,2	MPa
Resistencia a tracción	(i)	27,6	-	41,4	MPa
Elongación	(i)	100	-	600	% strain
Dureza-Vickers	(i)	6,2	-	11,2	HV
Resistencia a fatiga para 10 <sup>7</sup> ciclos	(i)	11	-	16,6	MPa
Tenacidad a fractura	(i)	3	-	4,5	MPa.m <sup>0.5</sup>

### Propiedades térmicas

Punto de fusión	(i)	150	-	175	°C
Máxima temperatura en servicio	(i)	100	-	115	°C
¿Conductor térmico o aislante?	(i)	Buen aislante			
Conductividad térmica	(i)	0,113	-	0,167	W/m.°C
Calor específico	(i)	1,87e3	-	1,96e3	J/kg.°C
Coefficiente de expansión térmica	(i)	122	-	180	µstrain/°C

### Propiedades eléctricas

¿Conductor eléctrico o aislante?	(i)	Buen aislante			
----------------------------------	-----	---------------	--	--	--

### Ecopropiedades

Contenido en energía, producción primaria	(i)	* 75,7	-	83,7	MJ/kg
Huella de CO <sub>2</sub> , producción primaria	(i)	* 2,96	-	3,27	kg/kg
Reciclaje	(i)	✓			
Marca de reciclaje	(i)				



Image 13: PP properties

Polyethylene (PE)<sup>6</sup>: is one of the most popular plastics because of its low cost, versatility and simplicity in its production. In addition, its excellent thermal and chemical resistance and its high resistance to impact, make it suitable for a wide variety of applications, from materials for the manufacture of containers and packaging or pipes for water and gas, to coatings for cables and films for agriculture .

Polyethylene is a polymer obtained from the polymerization of ethylene, which is a molecule that comes from the petroleum naphtha fraction. There are two types of polyethylene: high density polyethylene and low density polyethylene. The main difference between them is that high density polyethylene is harder and more rigid than low density polyethylene, but at the same time it is less deformable. As with other thermoplastics, both have the advantage of being recyclable.

### Propiedades generales

Densidad	(i)	939	-	960	kg/m <sup>3</sup>
Precio	(i)	* 1,44	-	1,48	EUR/kg

### Propiedades mecánicas

Modulo de Young	(i)	0,621	-	0,896	GPa
Límite elástico	(i)	17,9	-	29	MPa
Resistencia a tracción	(i)	20,7	-	44,8	MPa
Elongación	(i)	200	-	800	% strain
Dureza-Vickers	(i)	5,4	-	8,7	HV
Resistencia a fatiga para 10 <sup>7</sup> ciclos	(i)	21	-	23	MPa
Tenacidad a fractura	(i)	* 1,44	-	1,72	MPa.m <sup>0.5</sup>

### Propiedades térmicas

Punto de fusión	(i)	125	-	132	°C
Máxima temperatura en servicio	(i)	* 90	-	110	°C
¿Conductor térmico o aislante?	(i)	Buen aislante			
Conductividad térmica	(i)	0,403	-	0,435	W/m.°C
Calor específico	(i)	* 1,81e3	-	1,88e3	J/kg.°C
Coefficiente de expansión térmica	(i)	126	-	198	µstrain/°C

### Propiedades eléctricas

¿Conductor eléctrico o aislante?	(i)	Buen aislante			
----------------------------------	-----	---------------	--	--	--

### Ecopropiedades

Contenido en energía, producción primaria	(i)	* 77	-	85,1	MJ/kg
Huella de CO <sub>2</sub> , producción primaria	(i)	* 2,64	-	2,92	kg/kg
Reciclaje	(i)	✓			
Marca de reciclaje	(i)				



Image 14: PE properties

Conclusion: Once analyzed the two materials we must select the most suitable for the injection of our drone. Finally we opted for Polypropylene due to its mechanical characteristics such as tensile strength or compression, which are higher in this material. These characteristics are taken as a reference because if the drone suffers an accident the damage can be minimized.

## 1.8 ECONOMIC VIABILITY

### PROTOTYPE<sup>7</sup>

As previously stated, two ways to enter the market are sought.

#### 1.8.1 3d print:

To know the economic viability of the prototype, it is necessary to take into account the time of printing of each piece, the necessary material, the labor of the operator and the amortization of the machine.

- RAW MATERIAL: The cost of the raw material is 3.18 € / Kg of Nylon.

Upper Housing: 0.37 €

Lower Housing: 0.37 €

Propeller: 0.06 € (x4) = 0.24 €

Wing Support: 0.16 € (x4) = 0.64 €

Leg: 0.10 € (x4) = 0.40 €

- DRYING TIME: The nylon to be used needs a time of between 3 and 4 hours of drying before it can be used. This time causes the cost of the prototype to increase. +0.5€/h

- OPERATOR: An operator can be controlling several machines at the same time; due to cameras that record each machine and monitor it, or to sensors in the extruders the price can decrease per unit to 2€ / h.

- PRINTER: Ultimaker 3 Extended 3d Printer has a cost of € 3000 and its useful life is 3 years; every day can do work for 6 hours.

The cost of this printer is 1 € / h which will increase to € 1.5 / h due to maintenance and wear costs. The final price of the prototype is found in section MEASUREMENTS AND BUDGET, where is the breakdown by elements.

### 1.8.2 Manufacture in series with labor.

Despite being a prototype, manufacturing costs are developed by injection to see the viability of our product. For its production in series, a series of factors must be calculated, such as raw material, molds, injection or assembly machines, among others. The cost will be made to manufacture 100,000 pieces. In this way we will obtain a certain demand that will enhance the continuation of mass production, or else it will show that the product has not been successful in the market.

-MOLD: Mold for upper casing, this mold will cost € 20,000 due to its dimensions and curved areas. - Mold for lower housing, € 30,000 as it has curved and round areas and houses the supports of the wings, so it increases the price in order to obtain a single joint piece.

-MANO DE OBRA: For the development of the prototype, you need operators that control machines for injection, cutting and bending of metallic elements. Each of them will have a price according to their range of knowledge as it is reflected in the BUDGET

-MATTER: The material used to make the drone will be Polypropylene, since it has sufficient strength and can be used in injection processes.

Its price will be 1.7 € kg of PP and each piece will have different weight.

- Upper housing 0.15 kg
- Lower housing 0.25 Kg
- Leg: 0.0525 Kg (x4) = 0.21 Kg
- Support Ala 0.03 Kg (x4) = 0.12Kg
- Propeller 0.005 Kg (x4) = 0.02Kg

Total = 0.750 Kg

-ELECTRONIC DEVICES: The electronic elements are acquired in large quantities so the price will decrease considerably.

Electronic set 8€

-WAREHOUSE FOR STOCK: The units manufactured must be stored while the product is marketed.

Costs of € 500 rent during one year.

-MARKETING: The client must know the object and want it to increase sales -  
Costs of € 10,000 in marketing campaign.

-DISTRIBUTION: Costs of € 10,000

## 1.9 INTERNAL NEWS

The main novelties that the drone will have will be the adaptation of solar panels connected to the internal battery cells. In this way the drone would have an average autonomy of 30-40 min to unlimited, since during the flight the battery would recharge. In addition, the implementation of more powerful engines will allow companies to send their products up to 10 kg. Thanks to these innovations, we look for a little used and booming market.

To calculate the appropriate batteries and motors for our drone model, we will need to calculate the thrust. [8](#)

$$\text{Thrust} = \text{Aircraft weight} \times 2 / 4 \text{ engines}$$

Aircraft Weight:

-Engines and propellers: 500gr

-Frame: 750gr

-Battery: 400gr

-Flight controllers: 150gr

-Solar panels: 100gr

-Weight: 10.000gr max

Total: 11900gr

$$T = \frac{2W}{4} = \frac{2 \cdot 11900gr}{4} = 5950gr$$



Image 15: Drone position with package



Image 16: Drone position with package

In order to raise the drone we will need thrust motors between 5-10kg and Lipo 6-12 S batteries with a maximum capacity of 8300mAh that will be recharged during the flight.

To calculate the number of solar cells we need, we must investigate the average annual radiation of the place where they are going to be sold, that is, Spain.

Average annual radiation: 5,47 Kwh/m<sup>2</sup> <sup>9</sup>

Energy consumption: 22,2 Wh/day

$$N^{\circ} \text{ of solar cells} = \frac{\text{diarly energy} \cdot \text{days in a week}}{\text{Annual radiation} \cdot \text{work} \cdot \text{power}}$$

$$N^{\circ} \text{ of solar cells} = \frac{\frac{22,2Wh}{d} \cdot 7}{5,47h \cdot 0,6 \cdot 16,6W} = 4,84$$

5 solar cells are needed to recharge the battery of the drone.

In this way, it is decided to place a sixth solar cell. This is because the power consumption is faster than the battery charge. 5+1= 6

In addition, analysing the market study an increase in the safety of drones it is demanded. That is why it is intended to install an internal parachute that is activated at the time of a possible collision. In this way the propellers would stop in order not to cause sharp damage and the parachute would serve as an element of safety against a possible fall.



Image 17: Drone position with parachute

### 1.10 PROJECT CONCEPT SELECTION:

The selection is given by the main prototype to be made, as previously stated.

The project will have an upper and lower housing adapted with the wing supports, made of polypropylene; aluminium legs and carbon fiber propellers.



## 1.11 STRUCTURAL ANALYSIS:

For this project, we are going to study the possibility of a drone can transport loads up to 10 Kg, to be able to perform a delivery service of packages to people in a more economic and efficient way.

The drone will be subjected to static structural forces: a maximum pressure of 10 Kg on its rear surface and fixed supports on the legs.

The distribution of forces will allow us to know to what extent the drone can carry a weight without breaking.

Through the ANSYS program, we will know the total deformation and the stresses that are generated in the structure, in this way it will be possible to verify if the materials of the structure support the weight, or otherwise break.

Materials: Aluminium (legs), Polypropylene (supports and upper and lower housing), carbon fiber (propellers)

	Aluminium	Polypropylene	Carbon Fiber
<b>Density (kg*m<sup>-3</sup>)</b>	2698,4	900	1750
<b>Young's modulus (Pa)</b>	7e+10	1,3e+10	22e+10
<b>Poisson's Ratio</b>	0,34	0,43	0,25
<b>Elastic Limit (MPa)</b>	414	28,5	4000

Table 1: Material Properties

### Aluminium:

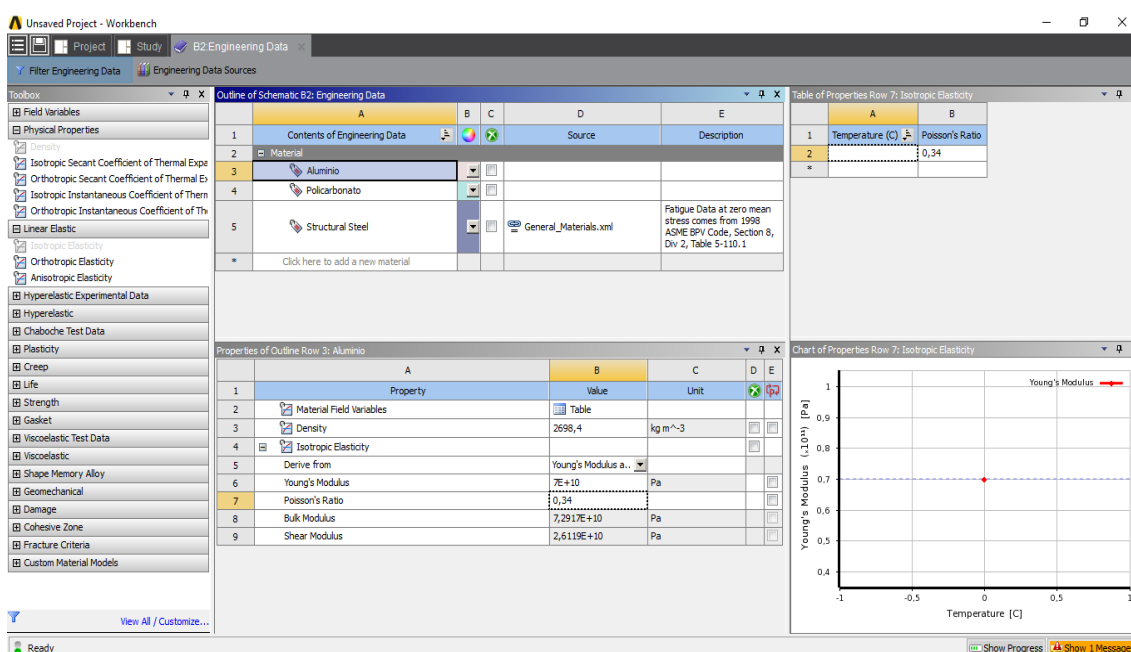


Image 18: Ansys Aluminium

## Carbon Fiber:

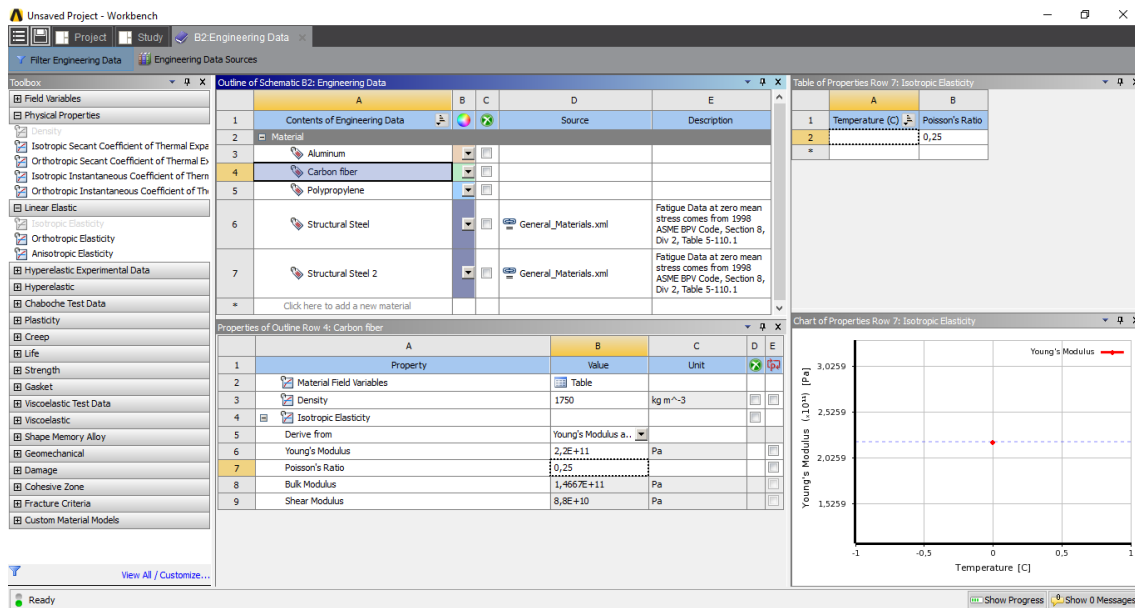


Image 19: Ansys Carbon fiber

## Polypropylene:

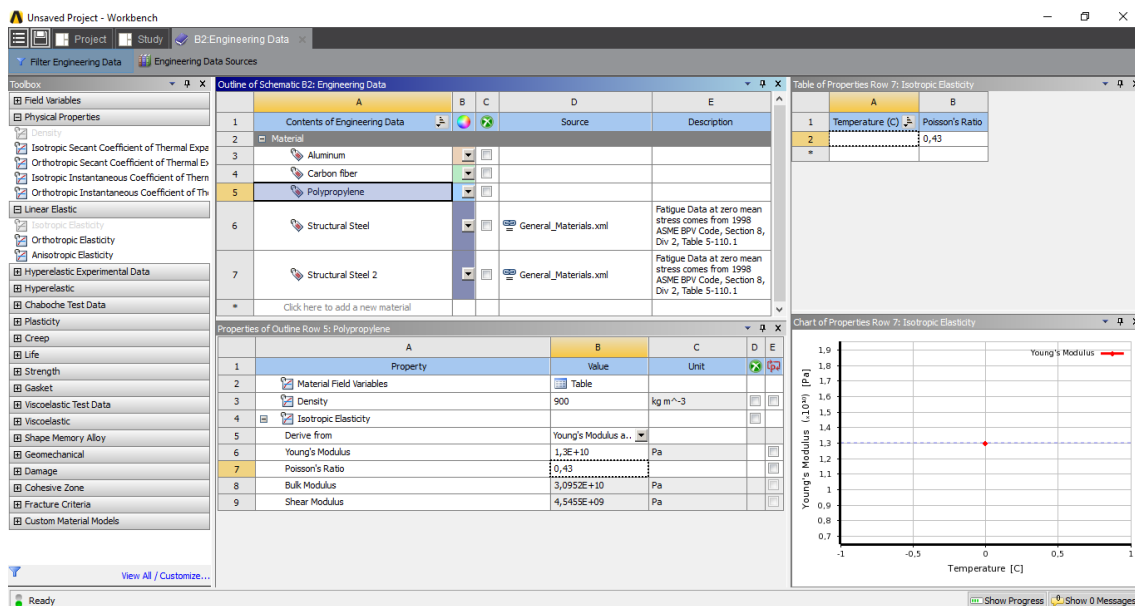


Image 20: Ansys Polypropylene

## Static Pressure:

To apply the pressure, first calculate the force that will be exerted respect to the area involved.

$$\text{Pressure} = \text{Force} / \text{Area} \longrightarrow P = 10\text{kg} \cdot 10 \text{ N} / 0,02034115 = 4916,18 \text{ Pa}$$

$$\text{Area} = 20341,15 \text{ mm}^2$$

As the pressure is distributed upwards, the negative sign must be added so that it is reflected that the weight that the drone will support will be in the direction of the -Y



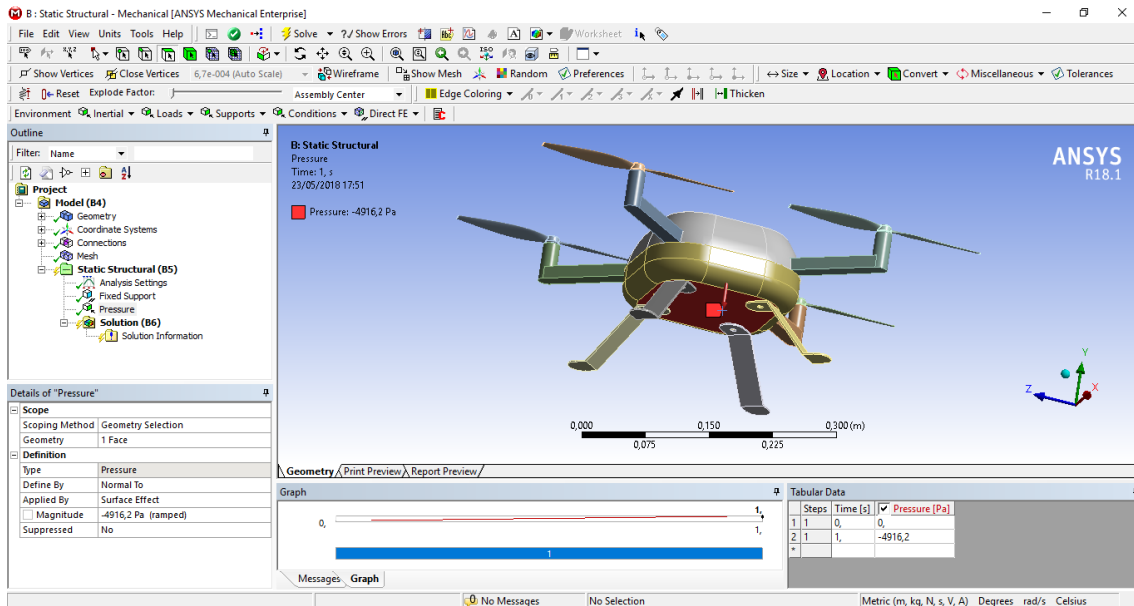


Image 21: Static pressure

For the solution, it is interesting to get the total deformation that the object is capable of supporting in order to check if the total deformation is higher than the elastic limit of the material. In this way, it is known if the material will break. In addition, the equivalent stress (von mises) is obtained to know which is the maximum tension that the material can support.

In order to Ansys calculate these parameters, we press the right button on Solution and Insert, and fix what we want to obtain. (Equivalent stress and Total Deformation)

### Analysis of the results

#### Total deformation:

As we can see, the critical point of the structure is the center of the lower housing, since the weight that must be supported is concentrated on that point.

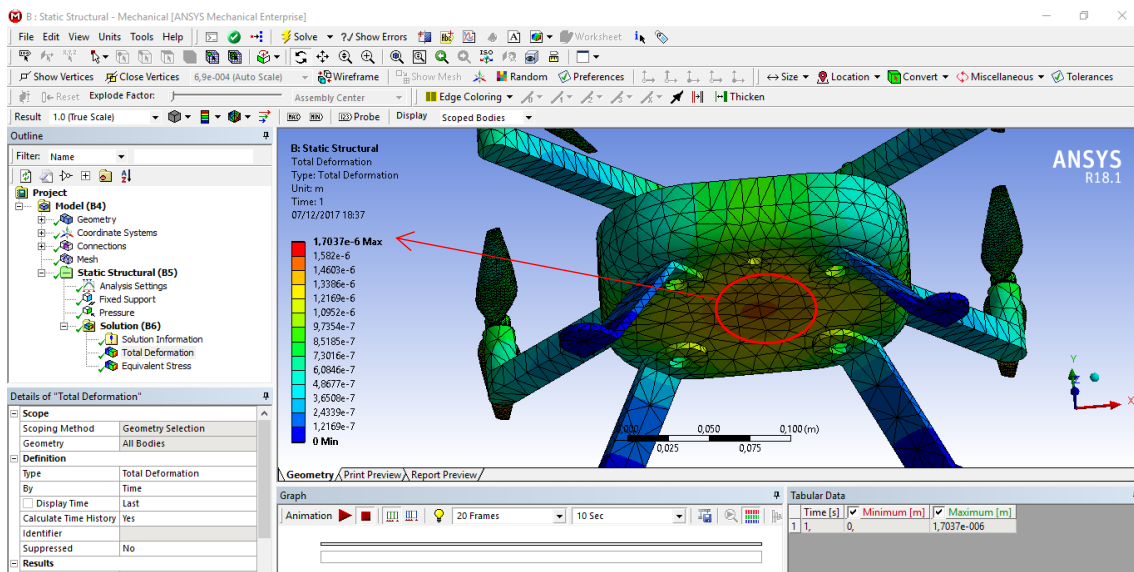


Image 22: Total deformation

The total deformation generated in that point is  $1,7037e-6m = 0,0017 \text{ mm}$

The total deformation is minimal, it is negligible, this is because the section of the legs is very thick and how is a metallic material can withstand much more weight than has been proposed in the case.

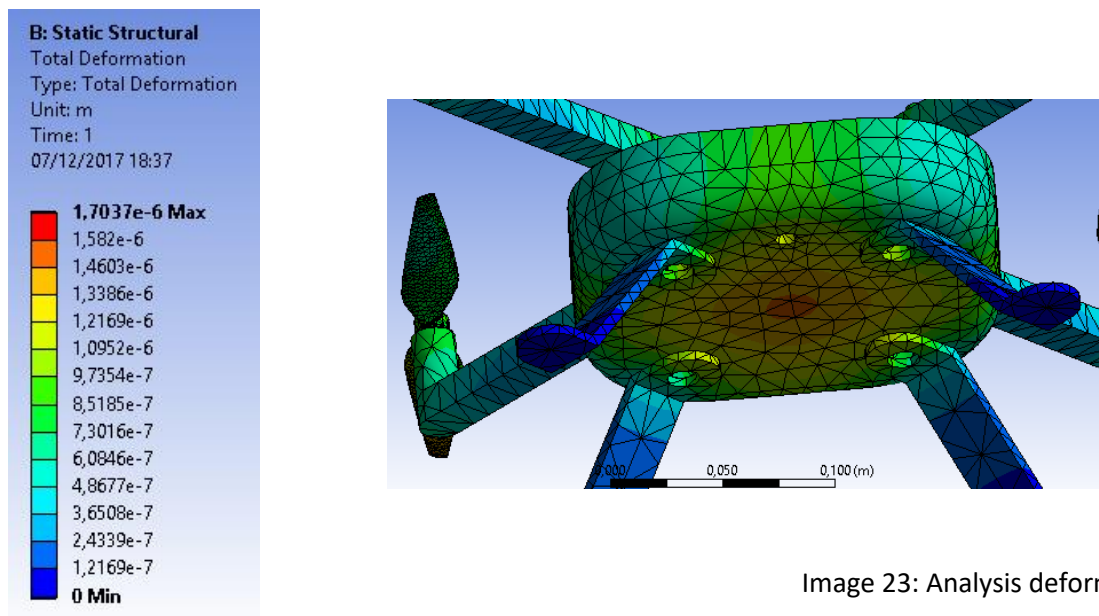


Image 23: Analysis deformation

Equivalent Stress (Von Mises):

The resulting tension of the material for the placed weight is minimal as well.

$4,6861e5Pa = 0,46861 \text{ Mpa}$

Aluminium has an elastic limit of 414 MPa.

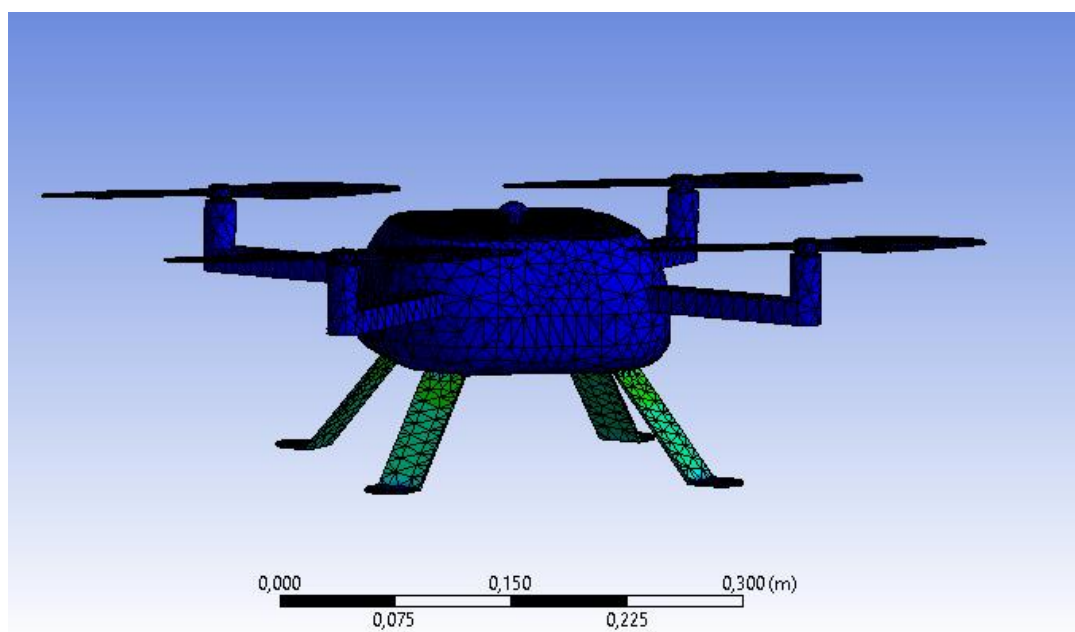


Image 24: Equivalent Stress Von Mises

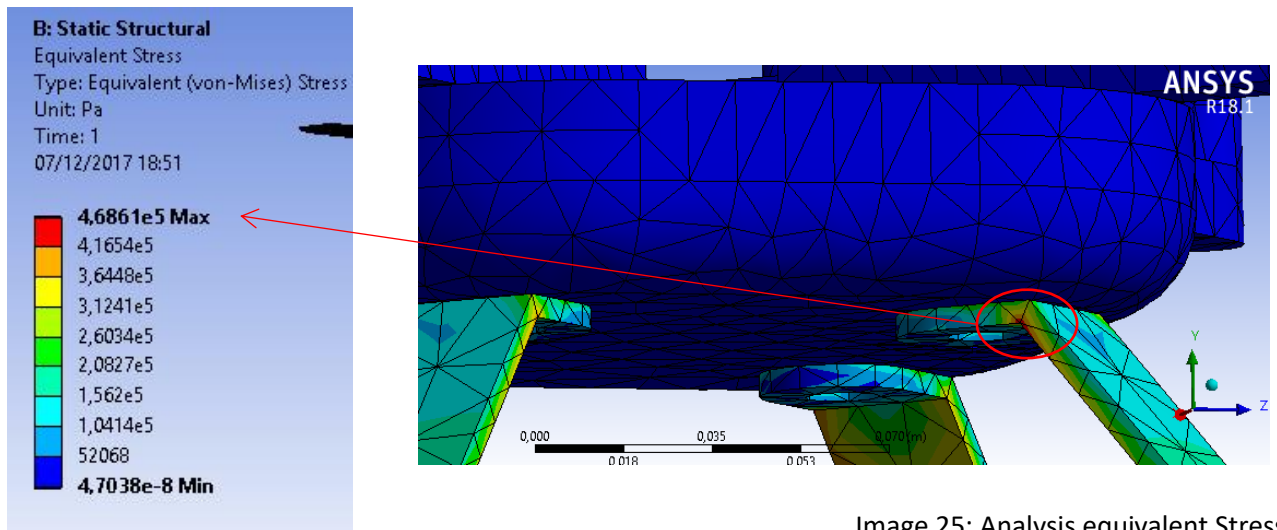


Image 25: Analysis equivalent Stress

The maximum tension is reflected in the lower edge of the leg, since it is the site that has the most tension. Even so, the tension is minimal and does not affect the structure.

Now each element will be checked separately to study how it would behave independently of the whole.

**Legs:** As described above, the total pressure that the legs must support is of 4916,18 Pa, as we are studying the behavior of one, we will divide the total pressure by 4, which is what each leg supports.

$$4916,18 \text{ Pa} / 4 = 1229,045 \text{ Pa}$$

Rest position without load:

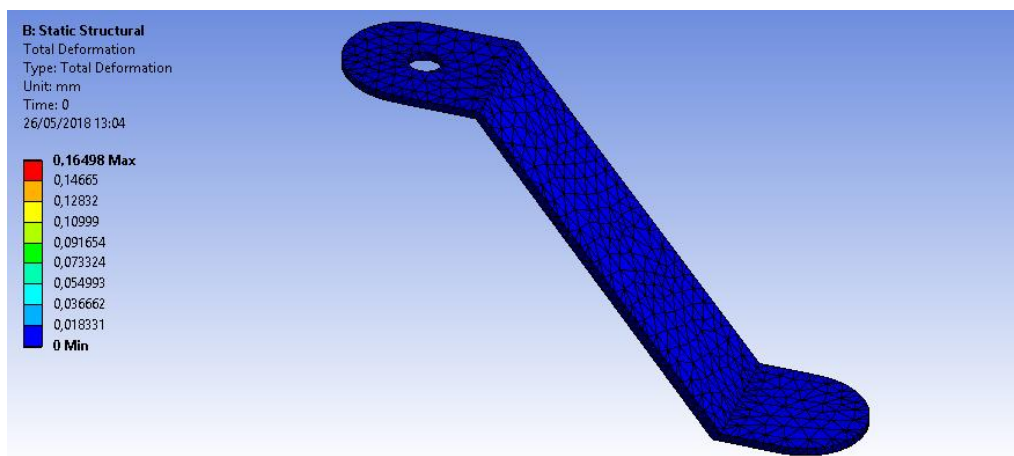


Image 26: Leg rest position

Position of tension with load:

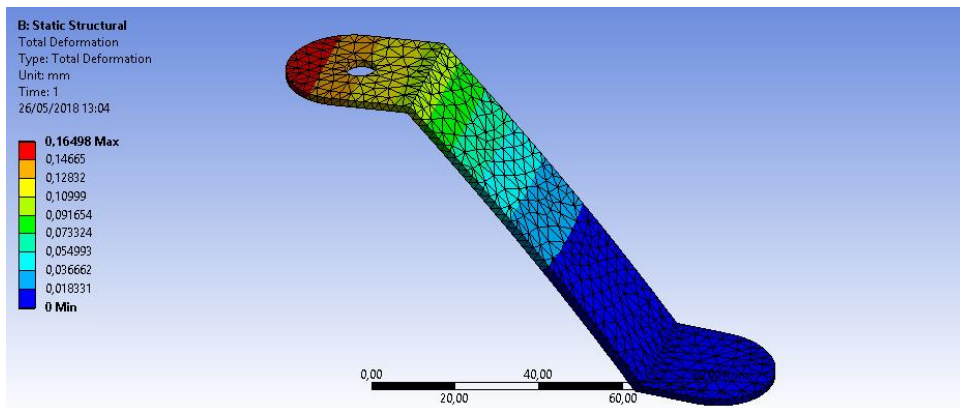


Image 27: Leg tensions with load

As can be seen, the upper zone of the leg is the one that suffers the most deformation due to the direct contact it suffers with a surface that supports the load. The maximum deformation is 0.165 mm, supporting 2.46 Mpa and the elastic limit of aluminum is 414 Mpa.

**Propeller:** The development of the helix is given by the air currents that originate during the flight. Next, the air cycle that the drone suffers during a normal flight is shown.

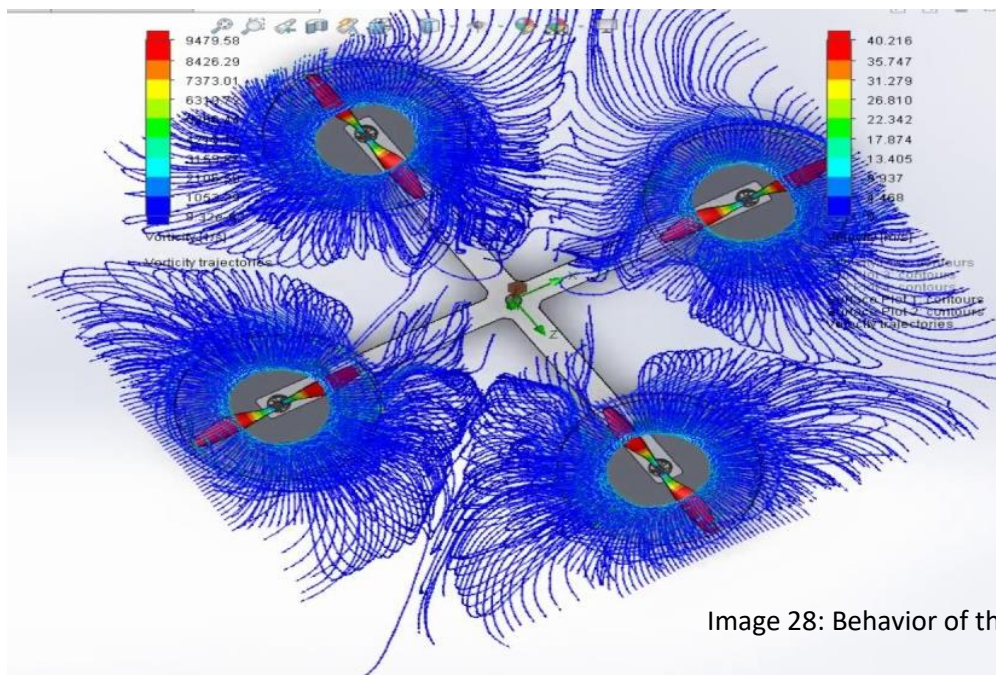


Image 28: Behavior of the propellers

For this, the lowest values of atmospheric pressure on the earth are used. This way the drone will be able to fly over anywhere. For this, pressures of 760 atm (mm of Hg) at sea level and 20° are calculated. The highest pressures are recorded at the ends and decrease as they approach the center point of the propeller.



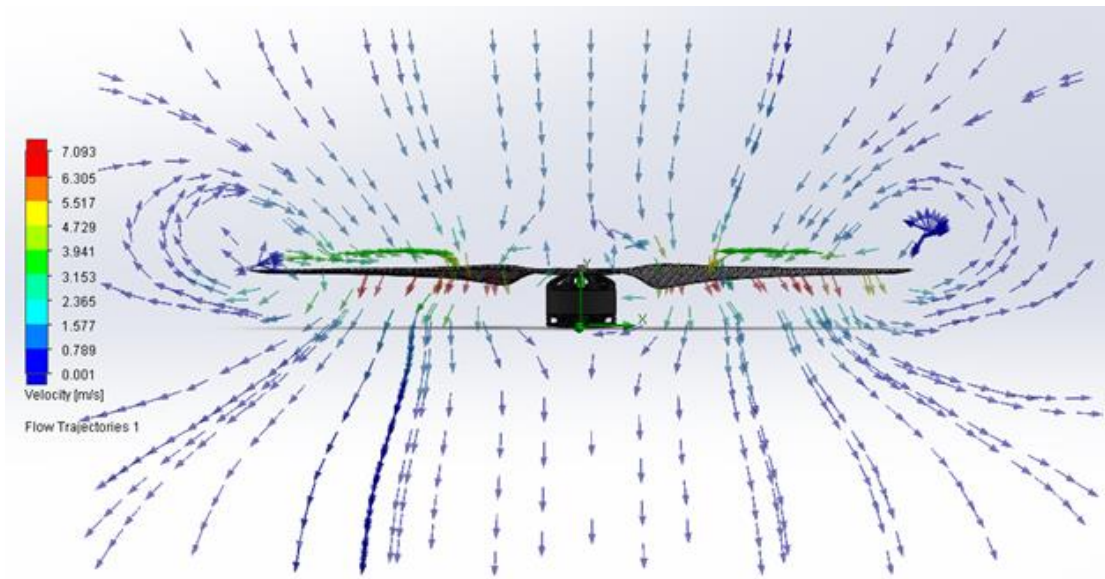


Image 29: Behavior of one propeller

**Wing support:** For this part it is important to know that the total pressure exerted will be the sum of the atmospheric pressure in the propellers and the weight of the propeller next to the engine.

Considering that the elastic limit of the Polypropylene is of 28 MPa, the pressure exerted on the supports is studied to know if the material will break or on the contrary sustain.

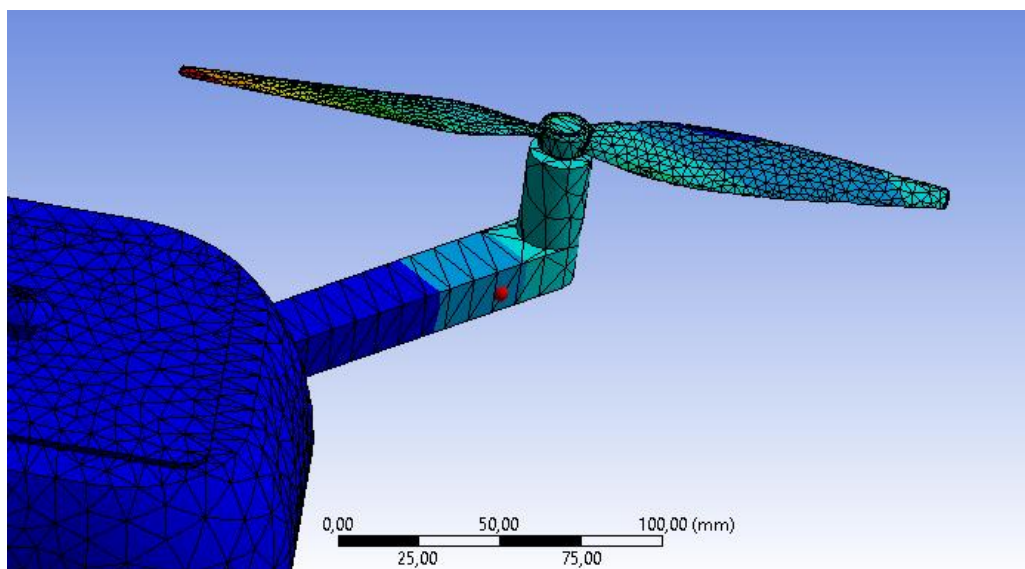


Image 30: Wing Support

The results obtained are:

The material will have a total deformation of 2 mm

The polypropylene will be able to withstand the stresses, since its elastic limit is 28 Mpa, and the tensions submitted are 15 Mpa

## 1.12 PRE-DIMENSIONING

The order of development and exposure of the previous dimensioning of the elements is carried out based on the priority criterion of the most related element. The relationships between elements are shown in the system diagram presented in APPENDIX 2.1.3

MARK	DENOMINATION	TYPE	Nº RELATIONS	ORDER
1.1.1	LOWER HOUSING	MANUFACTURE	4	1 <sup>o</sup>
3	SCREW	NORMALIZED	3	2 <sup>o</sup>
1.2	LEG	MANUFACTURE	3	3 <sup>o</sup>
2.1	UPPER HOUSING	MANUFACTURE	3	4 <sup>o</sup>
2.2	SOLAR CELL	NORMALIZED	2	5 <sup>o</sup>
2.3	PIVOT	NORMALIZED	2	6 <sup>o</sup>
4	WASHER	NORMALIZED	2	7 <sup>o</sup>
1.1.2	PROPELLER	NORMALIZED	1	8 <sup>o</sup>

Table 2: Pre-dimensioning

All type "A fabricate" elements are considered semi-finished, since they are made of aluminum sheet metal, like metal profile, which, after the sizing process, will be cut and in some cases, folded.

The normalization of the dimensions of the elements is done based on the standards, standard elements, tools and commercial elements that are described in the ANNEXES 2.2.1 to 2.2.7

## Element 1.1.1 Lower Housing

Related elements	
Mark	Noun
1.1.2	PROPELLER
1.2	LEG
2.1	UPPER HOUSING
3	SCREW

Table 3: Element 1.1.1 (Lower Housing)

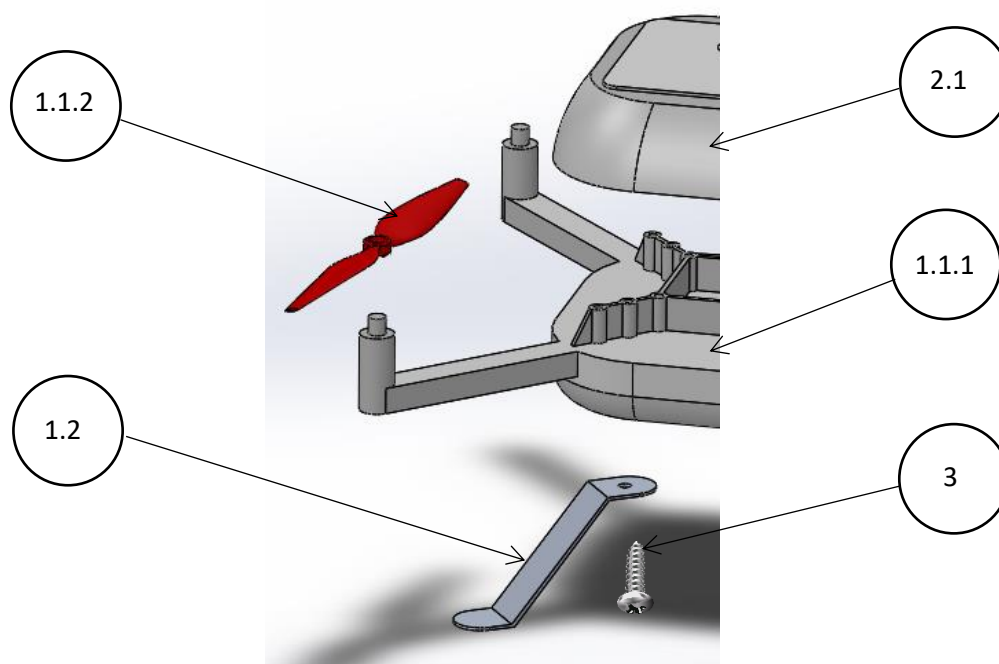


Image 31: Relations Element 1.1.1

Normalized elements		
Mark	Noun	Catalogue
1.1.2	PROPELLER	Carbon Fiber 240x8mm
1.2	LEG	Aluminum profiles 70x2mm
2.1	UPPER HOUSING	-
3	SCREW	Screws M7x20

Table 4: Normalized Elements 1.1.1 (Lower Housing)

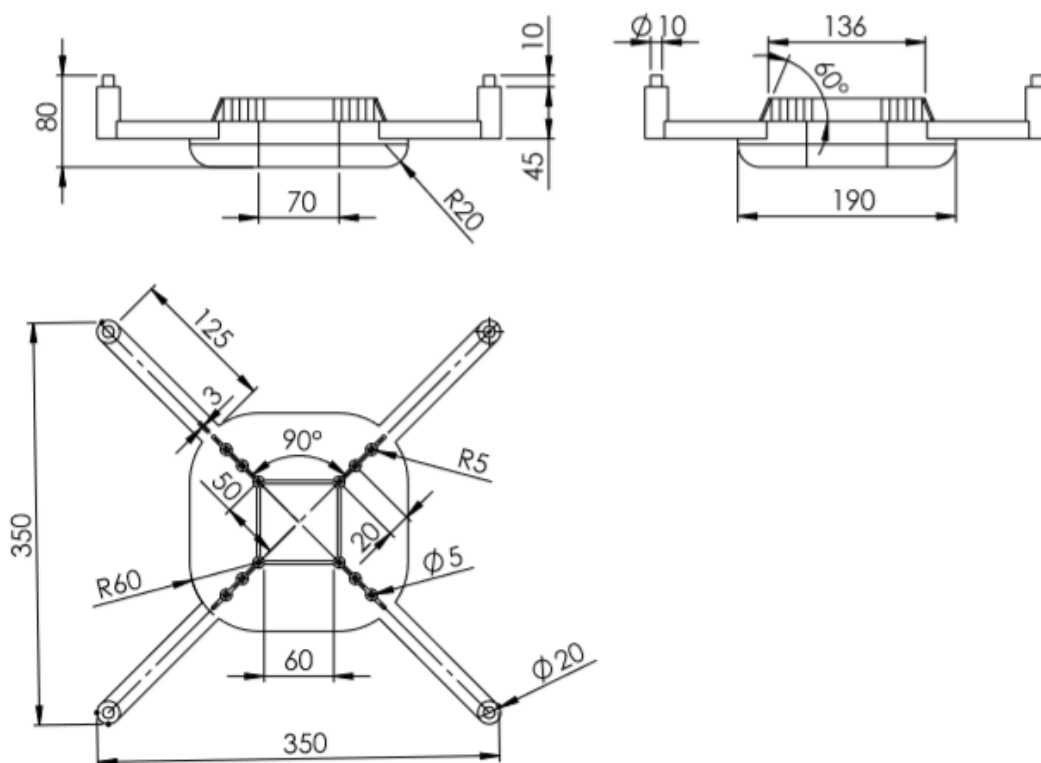


Image 32: Sub-set Plans 1.1.1

Support piece with hook that is shown resting on the legs and, in turn, holds the propellers at a balanced distance so that they can rotate. It is part of the subset 1.1 and is attached to the subset 2.1 by means of hooks.

350 mm: General measures of the drone.

90°: Position of the wing supports.

20 mm: Distance between holes.

∅ 10 mm: Hosting of the propellers

R 60 mm: Rounding the lower housing

45 mm: Height of the engines

125 mm: Length of the wing supports



## Element 1.1.2 Propeller

Related elements	
Mark	Noun
1.1.1	LOWER HOUSING

Table 5: Element 1.1.2 (Propeller)

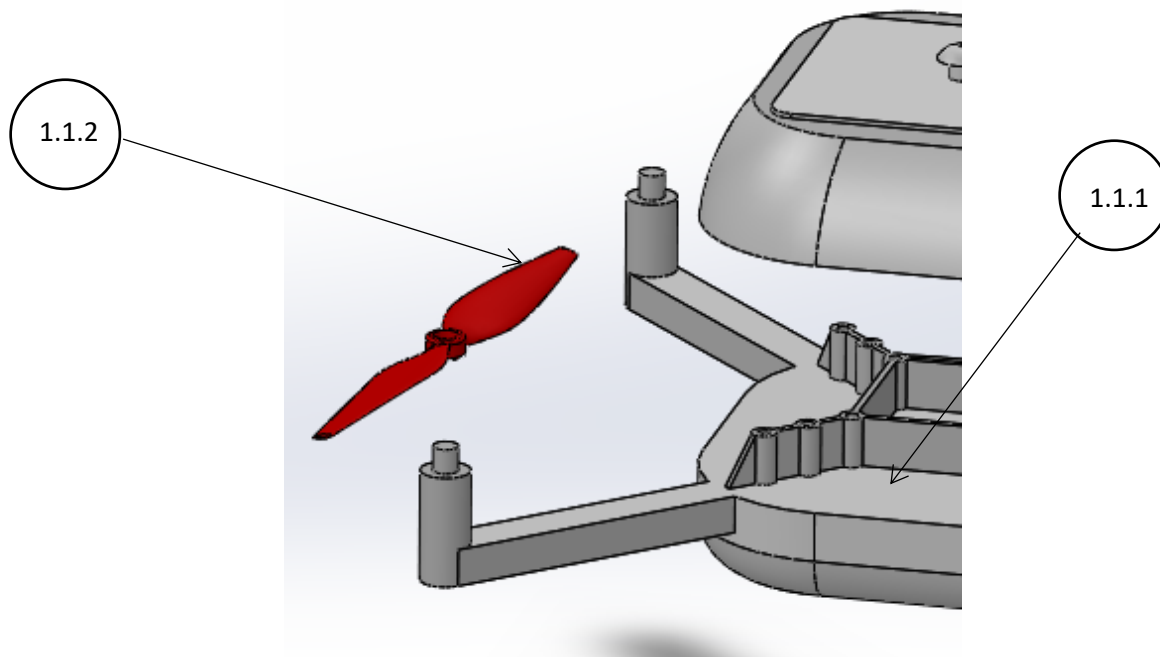


Image 33: Relations Element 1.1.2

Normalized elements		
Mark	Noun	Catalogue
1.1.1	LOWER HOUSING	-

Table 6: Normalized Elements 1.1.2

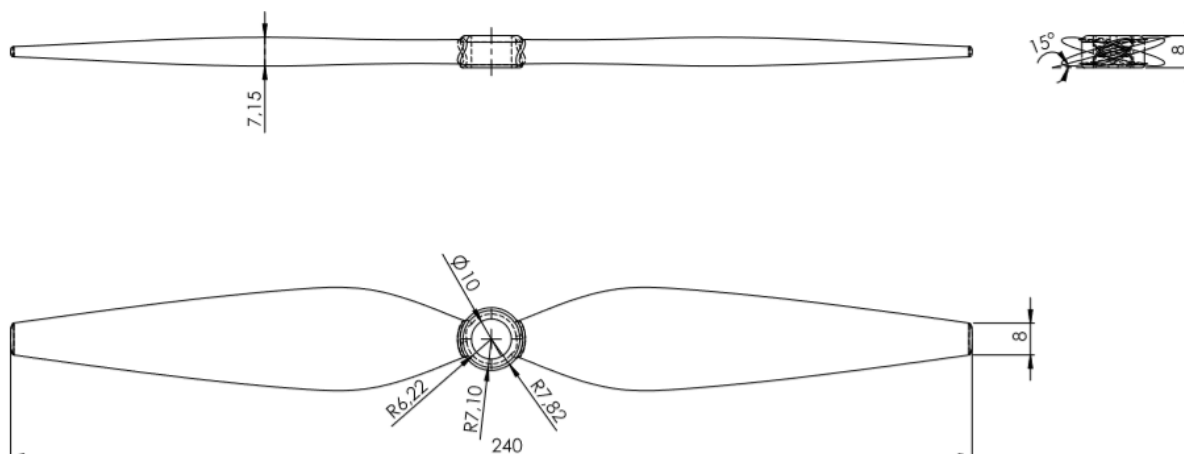


Image 34: Sub-set plans 1.1.2

Part of carbon fiber called helix, attached to the lower housing. It is part of the subset 1.1

240 mm: Total length of the propeller

8 mm: Total height of the propeller

15°: Torsion degree of the propeller

∅ 10 mm: Hosting of the propellers

R 7,82: Circular rounding radius

## Element 1.2 Legs

Related elements	
Mark	Noun
1.1.1	LOWER HOUSING
3	SCREW
4	WASHER

Table 7: Element 1.2 (Legs)

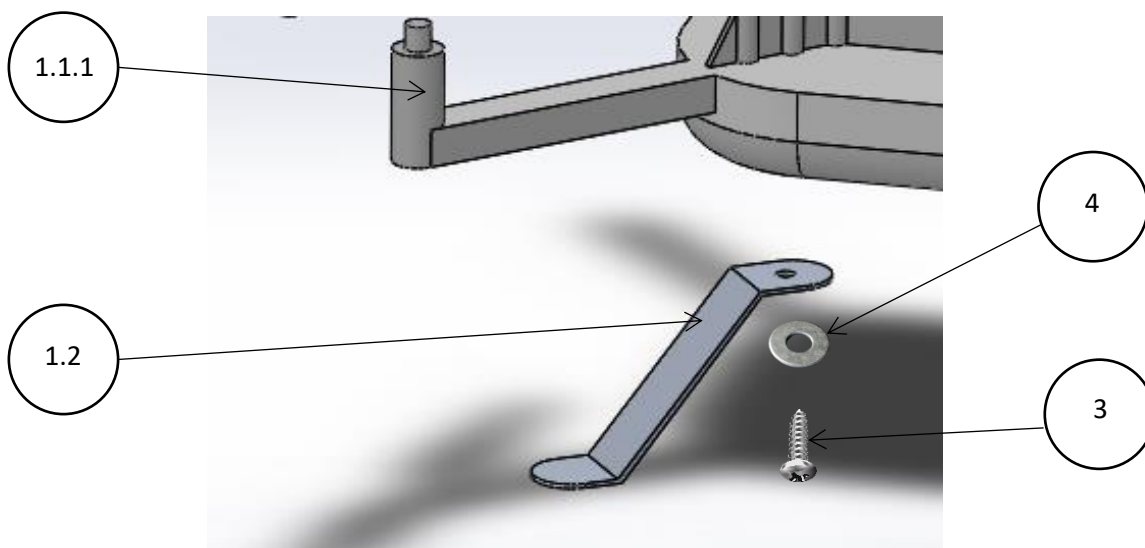


Image 35: Relations Element 1.2

Normalized elements		
Mark	Noun	Catalogue
1.1.1	LOWER HOUSING	-
1.2	LEG	Aluminum profiles 70x2 mm
3	SCREW	Screws M7x20 mm
4	WASHER	WASHERS M7x1,6 mm

Table 8: Normaliced Elements 1.2

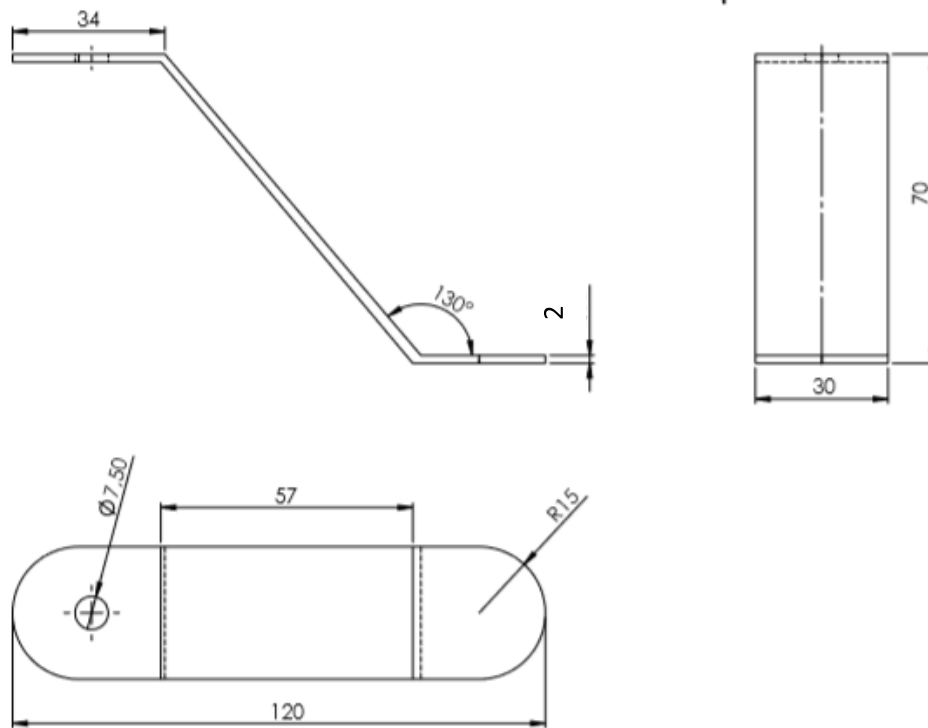


Image 36: Sub-set plans 1.2

Piece of ALUMINUM called leg, attached to the lower casing by means of screw (3) and washer (4). It is part of the subset 1.1. This piece is extracted from processes of cutting and bending sheet metal 70 x 2 mm.

70 mm: Total length of the propeller

30 mm: Total height of the propeller

∅ 7,50 mm: Diameter for the through screw

130°: Leg inclination respect to the horizontal

2 mm: Width of the leg

## Element 2.1 Upper Housing

Related elements	
Mark	Noun
1.1.1	LOWER HOUSING
2.2	SOLAR CELLS
2.3	PIVOT

Table 9: Element 2.1 (Upper housing)

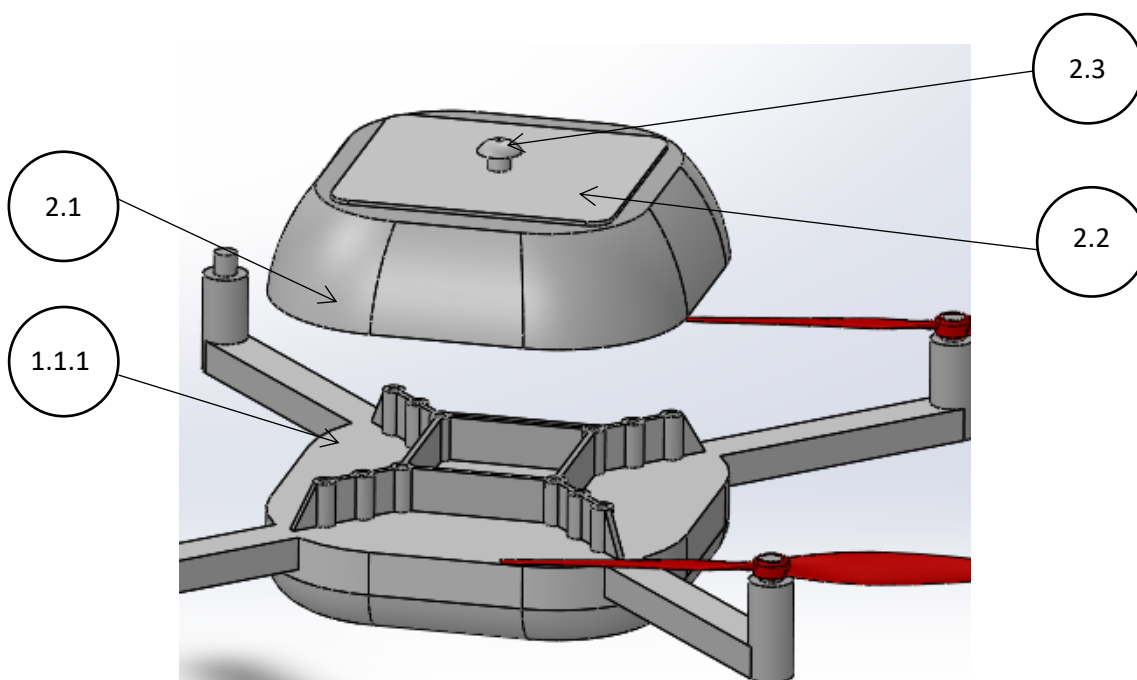


Image 37: Relations Element 2.1

Normalized elements		
Mark	Noun	Catalogue
1.1.1	LOWER HOUSING	-
2.2	SOLAR CELLS	CELLS 20x2 mm
2.3	PIVOT	P8xR10 mm

Table 10: Normaliced Elemenst 2.1



## 1.13 PROTOTYPE

This section is developed in a separate document.

## 1.14 CONCLUSIONS

After the previous dimensioning and the description of the prototyping carried out in a separate study, the design will be ready for the realization of tests and consequent readjustments both in dimensions and geometric shapes, for its improvement in resistance and manufacture. In addition a photo of the final prototype printed in 3D will be attached

## 1.9 INFORMATION SOURCES

The information that has been handled for the development of this study, classified according to its sources, is the following:

### Sources internal to the project:

#### Source

Designer

#### Information

Selected design

Conceptual design

Developer

Initial conditions document

Contract

### Sources external to the project:

#### SOURCE

Suppliers

#### INFORMATION

Screw catalog

Washer catalog

Pivot catalog

Catalog of solar cells

Aluminium catalog

Propellers catalog

## Administration [11](#)

ISO 21895 section, which refers to the categories of unmanned aerial systems.

ISO 21384-2 Here the safety requirements of the design and manufacture of the UAS will be defined.

ISO 21384-3 will focus on establishing the security requirements for the UAS operation.



## 2 ANNEXES

### 2.1 ANNEXES ON CONCEPTUAL DESIGN

#### 2.1.1 PROPOSED DESIGNS

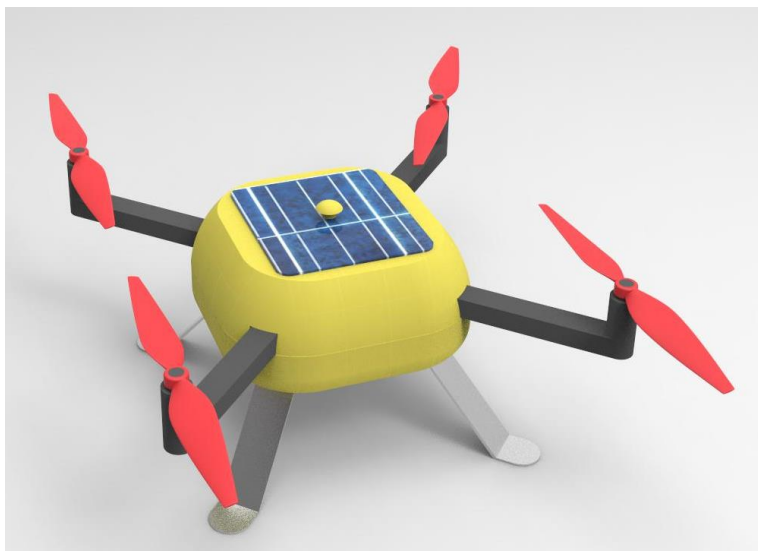


Image 39: Proposed designs

#### 2.1.2 DISASSEMBLY SCHEME

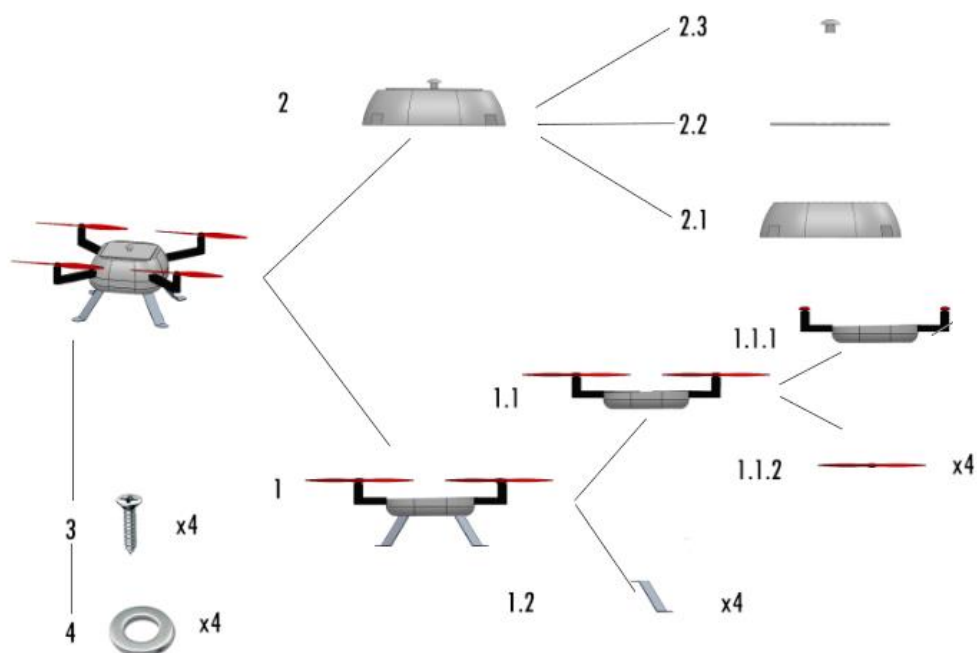


Image 40: Disassembly scheme

### 2.1.3 SYSTEMATIC DIAGRAM

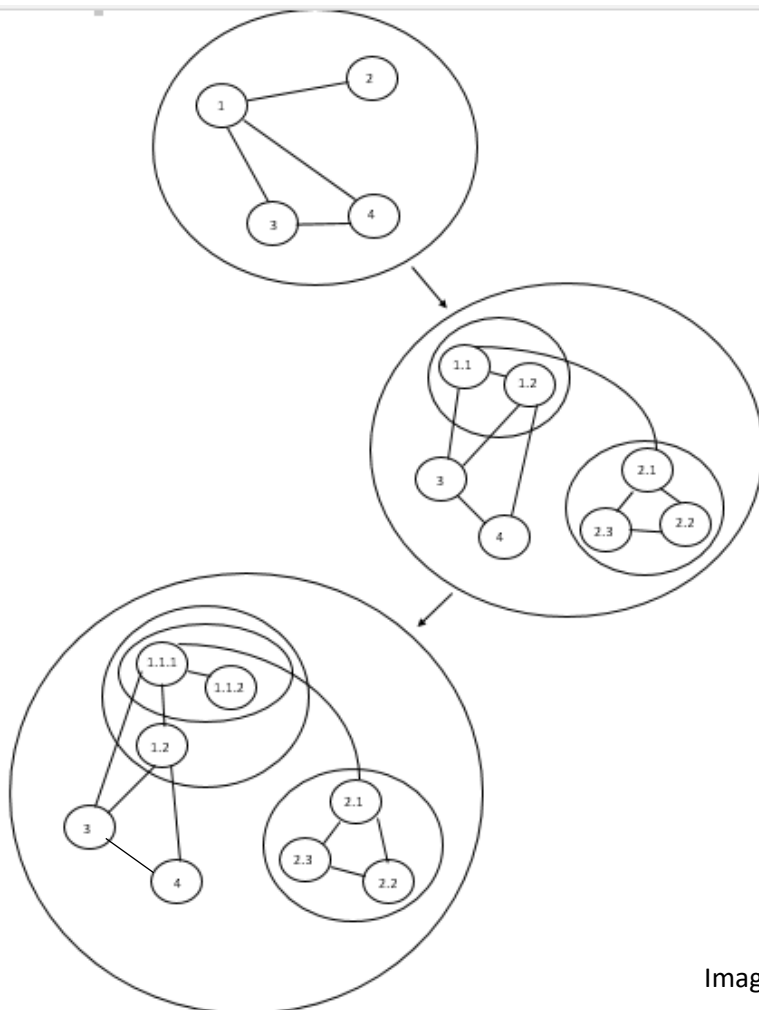


Image 41: Sistematic diagram

## 2.2 ANNEXES ON PREVIOUS DIMENSIONING

### 2.2.1 UNE NORMS OF APPLICATION [12](#)

#### ISO 21384-1

It is designed to establish the terminology and reference definitions for industry standards. This ISO also has another ISO 21895 section, which refers to the categories of unmanned aerial systems.

#### ISO 21384-2

Here the safety requirements of the design and manufacture of the UAS will be defined

#### ISO 21384-3

Finally, ISO 213843 will focus on establishing the security requirements for the UAS operation.

No doubt the sector is crying out for an international regularization, so that all those who are operating in the sector of the Drone can speak a common language.

The current trend of the use of Drones and UAS suggests that we will soon have many necessary jobs. Every day that passes we have a new model in the market, and it seems that this trend will accelerate in the near future.

Likewise, we must bear in mind that the regulation of the sector will be key to the business development of the same. The rules will mark what can and can not be done with the drones, defining the working model that can be done with the drones.

UNE-EN ISO 7250-1 Definitions of the basic measurements of the human body for technological design.

UNE 82100-0 Magnitudes and units.

UNE-EN ISO 6410-1 Threads and threaded parts, part 1: general agreement. Part 3: simplified representation).

LIMITATION REGULATIONS:

PROPORTIONS IN ACCOMMODATIONS

- UNE 1121                      - UNE 1032                      - UNE1034                      - UNE 1120
- UNE 1039                      - UNE 1110                      - UNE-EN ISO 6432
- UNE-EN ISO 7083

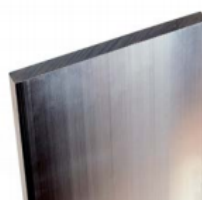
## 2.2.2 NORMALIZED ELEMENTS

LEGS [13](#): 70x2 mm

CATÁLOGO DE PERFILES NORMALIZADOS  
ALUMINIUM STANDARD PROFILES



Normalizados pletinas  
Extruded Flat Bars  
Fecha de actualización 13/04/2017  
Updated at 13/04/2017



Pletinas  
Flat Bars

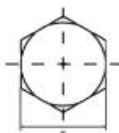
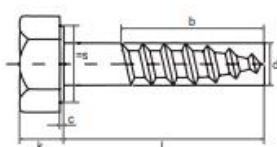
REF.	DESCRIPCIÓN mm	RADIO mm	PESO Kg/ml	PERIMETRO m2/ml
5990	60 x 10	0.3	1.620	0.139
6777	60 x 15	0.5	2.439	0.149
6778	60 x 20	0.5	3.252	0.159
8350	60 x 30	2	4.852	0.177
9168	70 x 2	0.2	0.378	0.144
5617	70 x 3	0.5	0.567	0.145
6108	70 x 12	0.5	2.268	1.163
6779	80 x 15	0.5	3.252	0.189
6780	80 x 40	0.5	8.672	0.239
6781	80 x 60	0.5	13.008	0.279
6540	88 x 5	0.3	1.188	0.185
6110	90 x 8	0.3	1.944	0.196

SCREW [14](#): M7 x 20

Image 42: metal catalog

### DIN 571

TORNILLO BARRAQUERO. ROSCA MADERA



d	5	6	7	8	10	12	14	16
b				b ≥ 6				
k	3.5	4	5	5.5	7	8	-	10
s	8	10	12	13	17	19	-	24

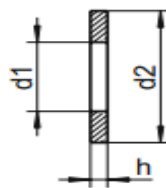
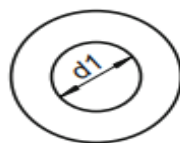
Zincado.

L	5	6	7	8	10	12	14	16
20	13012780	13012788	-	-	-	-	-	-
25	13012781	13012789	-	13012814	-	-	-	-
30	13012782	13012790	13012802	13012815	13012833	-	-	-
35	13012783	13012791	13012803	13012816	13012834	-	-	-
40	13012784	13012792	13012804	13012817	13012835	-	-	-
45	13012785	13012793	13012805	13012818	13012836	-	-	-
50	13012786	13012794	13012806	13012819	13012837	13012851	-	-

Image 43: Screw catalog

## WASHER 14: M7 x 1,6

### DIN 125 A - sim. ISO 7089 Arandela plana Forma A (sin bisel)



d1	para	d2	h	Grado	UV
1.7	M1,6	4.0	0.3	▲●	1000
1.8	M1,7	4.5	0.3	▲●	1000
2.2	M2	5.0	0.3	▲●	1000
2.5	M2,3	6.0	0.5	▲●	1000
2.7	M2,5	6.0	0.5	▲●	1000
2.8	M2,6	7.0	0.5	▲●	1000
3.2	M3	7.0	0.5	▲●	1000
3.7	M3,5	8.0	0.5	▲●	1000
4.3	M4	9.0	0.8	▲●	1000
5.3	M5	10.0	1.0	▲●	1000
6.4	M6	12.0	1.6	▲●	1000
7.4	M7	14.0	1.6	▲●	1000
8.4	M8	16.0	1.6	▲●	1000
10.5	M10	20.0	2.0	▲●	500
13.0	M12	24.0	2.5	▲●	500
15.0	M14	28.0	2.5	▲●	200
17.0	M16	30.0	3.0	▲●	200
19.0	M18	34.0	3.0	▲●	200
21.0	M20	37.0	3.0	▲●	200
23.0	M22	39.0	3.0	▲●	100
25.0	M24	44.0	4.0	▲●	100

Image 44: Washer catalog

## SOLAR CELLS 15

40

IRRADIACIÓN: AM 1.5, 1kw/m<sup>2</sup>

Variación de los valores de tensión y corriente en función de la temperatura.

TEMPERATURA DE LAS CÉLULAS 25°C

Variación de la tensión y la corriente en función de la irradiación.

**Especificaciones eléctricas y generales**

Ref.	48901005C
Potencia máxima	40 Vatios
Tolerancia de potencia máx	+15% / -5%
Voltaje a potencia máxima	16.9 Voltios
Corriente a potencia máxima	2.34 Amperios
Voltaje de circuito abierto	21.5 Voltios
Corriente de cortocircuito	2.48 Amperios
Longitud	107 mm
Anchura	118. mm
Profundidad	2 mm
Peso	kg.

Máximo voltaje del sistema: 750v  
Coeficiente de temperatura Voc: -8.21 x 10<sup>-2</sup>  
Coeficiente de temperatura Isc: 1.06 x 10<sup>-2</sup>

Image 45: Solar cells catalog

## PROPELLER



Image 46: Propeller catalog

## PIVOT [16](#)



VERS.	LTS	CIL	AÑO	USO	SIST.
-	1.4	L4	01-08	NAC.	MPFI
SEDAN	2.0	L4	00	NAC.	MPFI
CC	2.0	L4	01-06	NAC.	MPFI
SW	2.0	L4	01-06	NAC.	MPFI
SEDAN	2.0	L4	05-06	NAC.	MPFI
-	2.0	L4	03-05	NAC.	MPFI
-	2.2	L4	06-09	NAC.	MPFI
-	1.6	L4	97	IMP.	MPFI

Image 47: Pivot catalog



## 2.3 MANUFACTURING TOOLS

### -2.3.1 MACHINES FOR MANUFACTURING TOOLS

#### Manual lever shear FTX



Image 48: Shear Machine

The manual lever shear FTX is a guillotine table shear for the cutting of sheet steel width of bench up to 1050 mm and with cutting capacity up to 2 mm plate thickness. For cutting steel plates, aluminum, copper, etc. It is a robust and easy to use machine

Cutting thickness of 2 mm

Bed capacity 1,050 mm

Net / gross weight 235 kg

Dimensions with packaging (LxWxH) 1,550 × 1,000 × 5800 mm

## Milling machine Skill 2.0



Image 49: Milling machine

1300 W milling machine for cutting, chamfering, grooving and grooving edges and profiles. Variable speed: 12,000-28,000 r.p.m. to work a wide range of materials with different types of strawberries. Dust extraction option. Adjustable ergonomic handle for perfect control.

- Product weight 2.3 Kg
- Dimensions of the product 34.7 x 7 x 22 cm
- Voltage 230 V
- Electric power 1300 w
- Amperage 5.41 A
- Components included Straight cutter; 2 6 & 8mm handles

Column drilling machine SNC 23 VM

Drill developed by Syderic. It comes with a SNT3 base and a coolant unit. Accessories such as 24 V illuminations and electrical systems are also included with the device. In addition, the drill press can choose between a 1PH or 3PH motor.

-Voltage: 400 V

-Rotation speed:   Min .: 190 rpm  
                          Max .: 5250 rpm

- Power: 1100 W, 520 W

- Depth of drill 140 mm

- No. speeds 12

- Speeds 72/2600 rpm

- Distance axis-column 3400 mm

- Distance axis-table 650 mm

- Distance axis-base 1200 mm

- Column diameter 130 mm

- Dimensions table 500X450 mm

- Dimensions base 400X410 mm

- Slots 2 in perpendicular

- Total height 2120 mm



Image 50: Column Drilling

## Allrounder hybrid plastic injection molding machine



Image 51: Injection machine

The Allrounder 570 H high-performance hybrid has a clamping force of 2,000 kN and an injection unit of a size 800, and is equipped with a two-cavity mold.

A container made from PP, with a piece of 15.6 g in weight, will be manufactured in a work cycle of 3.5 seconds. The high performance machines of the Hidrive range offer maximum manufacturing capacity, as well as short work cycles and reduced energy consumption. Consequently, they are ideally suited for all types of wall applications.

## WE67K80 / 3200 CNC bending press (DA52) electro hydraulic servo



Image 52: Press machine

- Aerodynamic lines design, high speed, high precision, high rigidity, CNC sheet metal press.
- Electro-hydraulic servo system, the complete loop controls the synchronization of the upper beam.
- Hydraulic compensation at the top of the working table and compensation of throat deformation, ensuring good strength and folding precision.
- Rear stop driven by AC digital servo motor, moved with the long-stroke screw ball, guided by linear guide way.

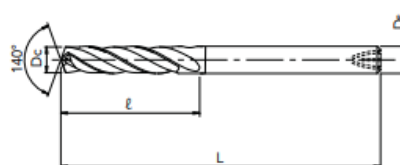
### Control technology

Bench press synchronization adopts full servo electro-hydraulic loop control technology, the upper beam positioning signal is fed back by the raster (light rule) to the CNC system and the CNC system will check the opening size and synchronization valves, adjusting the amount of oil input, to perform the synchronization of movements of the upper beam (Y1, Y2), and keep the work table always in parallel situation. Following the situation of the metal sheet to be bent, the CNC system automatically controls the amount of working table compensation coronation to realize that the angle being bent of the work piece can maintain it along the full length of the workpiece. the piece.

## -TOOLS

Metric Drill [17](#) Bits 7 Diameter 7.50mm for metal

### TRS-HO-3D



● Legenda de icones verifique pág. 4 | Leyenda de los iconos consulte pág. 4

Unid.:mm

EDP No.	Dc	ℓ	L	Ds	Estoque Stock	Preço Price
48157050	5	25	80	6	●	R\$ 755,12
8660510	5,1	26	82	6	☹	R\$ 383,58
8660520	5,2	26	82	6	☹	R\$ 383,58
8660530	5,3	27	82	6	☹	R\$ 383,58
8660540	5,4	27	82	6	☹	R\$ 383,58
8660550	5,5	28	82	6	●	R\$ 383,58
48157555	5,55	28	82	6	☹	R\$ 563,35
8660560	5,6	28	82	6	☹	R\$ 542,74
8660570	5,7	29	82	6	☹	R\$ 404,90
8660580	5,8	29	82	6	☹	R\$ 404,90
8660590	5,9	30	82	6	☹	R\$ 404,90
8660600	6	30	82	6	●	R\$ 357,40
48157061	6,1	31	88	8	☹	R\$ 840,76
48157062	6,2	31	88	8	☹	R\$ 840,76
48157063	6,3	32	88	8	☹	R\$ 840,76
48157064	6,4	32	88	8	☹	R\$ 840,76
48157065	6,5	33	88	8	●	R\$ 840,76
48157066	6,6	33	88	8	☹	R\$ 887,98
48157067	6,7	34	88	8	☹	R\$ 887,98
48157068	6,8	34	88	8	●	R\$ 887,98
48157069	6,9	35	88	8	☹	R\$ 887,98
48157070	7	35	88	8	●	R\$ 887,98
8660710	7,1	36	94	8	☹	R\$ 503,76
8660720	7,2	36	94	8	☹	R\$ 503,76
8660730	7,3	37	94	8	☹	R\$ 503,76
8660740	7,4	37	94	8	●	R\$ 503,76
8660750	7,5	38	94	8	●	R\$ 503,76
48157755	7,55	38	94	8	☹	R\$ 913,41
8660760	7,6	38	94	8	☹	R\$ 532,55
8660770	7,7	39	94	8	☹	R\$ 532,55
8660780	7,8	39	94	8	☹	R\$ 532,55
8660790	7,9	39	94	8	☹	R\$ 532,55
8660800	8	40	94	8	●	R\$ 470,03
48157081	8,1	41	101	10	☹	R\$ 1.020,32
48157082	8,2	41	101	10	☹	R\$ 1.020,32
48157083	8,3	42	101	10	☹	R\$ 1.020,32
8660920	9,2	46	106	10	☹	R\$ 641,94
8660930	9,3	47	106	10	●	R\$ 641,94
8660940	9,4	47	106	10	●	R\$ 641,94
8660950	9,5	48	106	10	●	R\$ 641,94
48157955	9,55	48	106	10	☹	R\$ 1.122,56
8660960	9,6	48	106	10	☹	R\$ 696,72
8660970	9,7	49	106	10	☹	R\$ 696,72
8660980	9,8	49	106	10	☹	R\$ 696,72
8660990	9,9	50	106	10	☹	R\$ 696,72
8661000	10	50	106	10	●	R\$ 696,72
48157101	10,1	51	113	12	☹	R\$ 1.194,18
48157102	10,2	51	113	12	☹	R\$ 1.194,18
48157103	10,3	52	113	12	●	R\$ 1.194,18
48157104	10,4	52	113	12	☹	R\$ 1.194,18
48157105	10,5	53	113	12	●	R\$ 1.194,18
48157106	10,6	53	113	12	☹	R\$ 1.224,29
48157107	10,7	54	113	12	☹	R\$ 1.224,29
48157108	10,8	54	113	12	●	R\$ 1.224,29
48157109	10,9	55	113	12	☹	R\$ 1.224,29
48157110	11	55	113	12	●	R\$ 1.224,29
8661110	11,1	56	120	12	☹	R\$ 804,94
8661120	11,2	56	120	12	●	R\$ 804,94
8661130	11,3	57	120	12	●	R\$ 804,94
8661140	11,4	57	120	12	●	R\$ 804,94
8661150	11,5	58	120	12	●	R\$ 804,94
8661160	11,6	58	120	12	☹	R\$ 897,69
8661170	11,7	59	120	12	☹	R\$ 897,69
8661180	11,8	59	120	12	☹	R\$ 897,69
8661190	11,9	60	120	12	☹	R\$ 897,69
8661200	12	60	120	12	●	R\$ 792,35
48157125	12,5	63	128	14	●	R\$ 1.377,39
48157130	13	65	128	14	☹	R\$ 1.530,49
8661350	13,5	68	134	14	☹	R\$ 1.194,84
8661400	14	70	134	14	☹	R\$ 1.194,84
48157145	14,5	73	140	16	☹	R\$ 1.673,21
48157150	15	75	140	16	☹	R\$ 1.714,21

Image 53: Drill Catalog

The Ø 7.5 mm drill bit is used to generate the holes in SUBCONJUNTO 1.2 and can be assembled by screws (3) to the lower housing (1.1.1)

### -2.3.2. MACHINE FOR PRINT 3D [20](#)

The Zortrax M200 Zortrax 3D printer is a plug & play printer that can print layers up to 25 microns with PLA, ABS or Nylon filaments. The printer includes the Z-Suite software and is compatible with Windows (XP / Vista / 7 +), Mac OS X and Linux. You can print objects with a maximum size of 205x205x190.



Image 54: 3D printer

Material (s): PLA, ABS, Special filaments

Technology: Deposition of molten material

Assembly: Plug & play

Size: 430x360x345

Weight (kg): 13.5

Diameter of the extruder (mm): 0.4

Thickness of the layer: 90

Speed (mm / s): -

Accuracy (mm): XY: 1.5  $\mu$ m - Z: 1.25  $\mu$ m

Strand size (mm): 1.75

Maximum production volume (mm): 200x200x185

Type of files: .stl, .obj

Software: Z-Suite

Connectivity: -

Operating systems: Windows (XP / Vista / 7 +), Mac OS X, Linux

Power: 100-240V ~ 2 amps 50-60 Hz



## 2.4 TOOLS FOR ASSEMBLY

Sergeant Leroy Merlin



Image 55: Sergeant

Special clamping and clamping tool for different jobs. 160 mm opening

-Tools and supplies

Kinpex jaws



Image 56: Kinpex jaws

- Chromed finish for better resistance to corrosion.
- Left to unlock with one hand.
- Screw to adjust the mouth and amount of pressure to exercise.
- Size of 180 mm.

STANLEY 1-65-412 [18](#) - Insulated screwdriver vde 1000v FatMax flat 4 x 100 mm

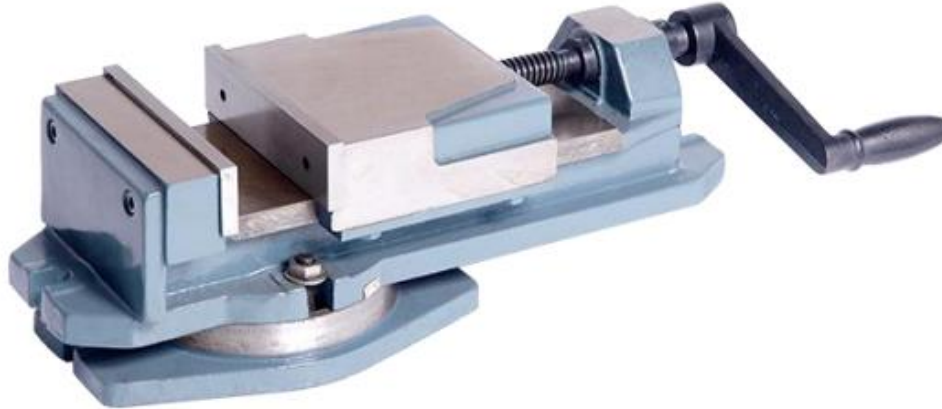


Image 57: Screw driver

Electrician's screwdriver with ergonomic, large-diameter bimetallic handle, which offers a high torsional capacity. Slim neck for fast rotation. The handle is molded directly on the steel rod. It can be hung thanks to its hole in the handle. Color code on the handle for identification of tip type. Industrial quality 1,000V a.c isolation. Individually tested standard EN60900: 2004. Protects from current up to 1,000V a.c. Protective polyamide insulating cover extremely resistant up to a temperature of -25°C, which ensures resistance to corrosion and minimizes the risk of moisture absorption. SKU Tip width (mm) Blade length (mm) 65-410 2.5 50 65-411 3.5 75 65-412 4 100 65-413 5.5 150

## Bed pressure screw

### Universal jaws with rotating base



MODELO	MU125	MU150	MU200
CÓDIGO	1000524	1000525	1000526
ANCHO BOCA (MM)	125	150	200
ALTURA BOCA (MM)	37	40	58
APERTURA BOCA (MM)	85	114	150
LONGITUD TOTAL (MM)	370	462	620
ALTURA TOTAL (MM)	128	145	202
PESO (KG)	17	28	58

Image 58: Bed pressure screw

The bench press screw serves to hold the parts in the drill and allow both a better grip and support, thus allowing the piece to be held does not oscillate or cause movement.

## 2.5 COMMERCIAL ELEMENTS FOR MANUFACTURING SCREWS



Image 59: Screw box

## PROPELLERS



Image 60: Propeller Box



## WASHERS



Image 61: Washer Box

## PLASTIC IN PELLETS for inyection



Image 62: Pellets Box

## 2.5.1 COMERCIAL ELEMENTS FOR PRINTING 3D

-Nylon [19](#)



Diámetro: 1,75mm o 2,85 mm

Image 63: Nylon filaments

Temperatura nozzle ideal (impresión): 230°C

Rango de temperaturas de impresión: 228-235 °C

Temperatura base impresión: No necesaria. (Recomendable a 45 °C).

Cantidad Neta: 450gr (1lb)

Uso Alimentario: No Aprobado

Diámetro bobina: 200mm (Ø 1.75mm) / 130mm (Ø 3mm)

Ancho bobina: 50mm (Ø 1.75mm) / 70mm (Ø 3mm)

Diámetro agujero interior: 50mm (Ø 1.75mm) / 19mm (Ø 3mm)

-Carbon Fiber [21](#)



Image 64: Carbon Fiber filaments

The Filament 3d Special Carbon Fiber 1.75mm of Color Plus, with tolerances of diameter of  $\pm 0,05\text{mm}$  or less, guarantee a constant supply and stable impressions, always.

### 3. Technical specifications

The following are the technical conditions necessary for the construction of the armchair prototype for each piece, subset and final assembly:

#### Piece 1.1.1 (Lower Housing)

Starting material: Plastic pellets

Operation	1 <sup>a</sup>	Injection
-Machine		Plastic injection molding machine
-Manufacturing		injection work can be carried out by an operator with a minimum category of "2 <sup>nd</sup> Officer"
-Media Assistant:		
-Supplies		Mold
-Tools		Not precise
Development:		
1 <sup>o</sup> -		Placement of the pellets in Plastic injection molding machine
2 <sup>o</sup> -		Placement of the mold
3 <sup>o</sup> -		Placement parameters in in Plastic injection molding machine
4 <sup>o</sup> -		Start-up Plastic injection molding machine
5 <sup>o</sup> -		Pick up the piece
-Safety		Gloves, goggles, work clothes and safety shoes.
-Controls		
1 <sup>o</sup> -		Check the good condition of the machine
2 <sup>o</sup> -		Check the good condition and placement of the mold
3 <sup>o</sup> -		Check the parameters of the machine
4 <sup>o</sup> -		Check the final dimensions of the piece
-Tests		Every 100 units Resistance and hardness

Table 11: Lower Housing Injection

#### Piece 1.2 (Legs)

Starting material: Aluminum sheet

Operation	1 <sup>a</sup>	Shear
-Machine		Manual lever shear
-Manufacturing		Shear work can be carried out by an operator with a minimum category of "3 <sup>rd</sup> Officer"
-Media Assistant:		
-Supplies		Not precise
-Tools		Hooks
Development:		
1 <sup>o</sup> -		Placement of bar in the machine to the determined measure (150 mm).
2 <sup>o</sup> -		Placement of the saw blade to a certain size (90 °).
3 <sup>o</sup> -		Start-up of the machine
4 <sup>o</sup> -		Cutting of the material in the given measurement (150 mm)
-Safety		Gloves, goggles, work clothes and safety shoes.
-Controls		
1 <sup>o</sup> -		Check the good condition of the machine
2 <sup>o</sup> -		Check the good condition and placement of the saw blade
3 <sup>o</sup> -		Check the perpendicularity of the shear
4 <sup>o</sup> -		Check the final dimensions of the piece
-Tests		Not precise



Operation		2 <sup>a</sup>	Edge rounding
-Machine		Milling machine Skill 2.0	
-Manufacturing		Rounding work can be carried out by an operator with a minimum category of "3 <sup>rd</sup> Officer"	
-Media Assistant:			
-Supplies		Mills (5mm)	
-Tools		Hooks	
Development:			
1 <sup>o</sup> -	Placement of bar in the machine to the determined measure		
2 <sup>o</sup> -	Placement the parameters in the machine		
3 <sup>o</sup> -	Start-up of the machine		
4 <sup>o</sup> -	Cutting of the material in the given edge rounding		
-Safety		Gloves, goggles, work clothes and safety shoes.	
-Controls			
1 <sup>o</sup> -	Check the good condition of the machine		
2 <sup>o</sup> -	Check the good condition and placement of the mills		
3 <sup>o</sup> -	Check the perpendicularity of the shear		
4 <sup>o</sup> -	Check the final dimensions of the piece		
-Tests		Not precise	

Table 12: Aluminium Rounding

Operation		3 <sup>a</sup>	Holey
-Machine		Column drilling machine SNC 23 VM	
-Manufacturing		Holey work can be carried out by an operator with a minimum category of "3 <sup>rd</sup> Officer"	
-Media Assistant:			
-Supplies		Bench pressure screw, flexometer	
-Tools		Drill for metal Ø 7.5 mm	
Development:			
1 <sup>o</sup> -	Fixing of pressure screw in bedplate Drilling hole.		
2 <sup>o</sup> -	Placement of Ø 7.50 mm bit in the drill		
3 <sup>o</sup> -	Mark centers of holes and punch before placing the piece in a pressure screw		
4 <sup>o</sup> -	Placement of part in pressure screw in bench: it is seen the face of greater length and the mark of the hole of Ø 7.50 mm aligned with the bit.		
5 <sup>o</sup> -	Drilling hole.		
-Safety		Gloves, goggles, work clothes and safety shoes.	
-Controls			
1 <sup>o</sup> -	Check the good condition of the machine		
2 <sup>o</sup> -	Check the good condition and placement of the bench pressure screw		
3 <sup>o</sup> -	Check the good condition and placement of the drill		
4 <sup>o</sup> -	Check the final holes dimensions of the piece		
-Tests		Not precise	

Table 13: Aluminium Holey



Operation		4 <sup>a</sup>	Curved
-Machine		WE67K80 / 3200 CNC bending press (DA52) electro hydraulic servo	
-Manufacturing		Curved work can be carried out by an operator with a minimum category of "2 <sup>nd</sup> Officer"	
-Media Assistant:			
-Supplies		Mold	
-Tools		Not precise	
Development:			
1 <sup>o</sup> -	Fixing the mold in the curved		
2 <sup>o</sup> -	Placement of aluminium sheet		
3 <sup>o</sup> -	Placement the parameters in the machine		
4 <sup>o</sup> -	Curved by press		
5 <sup>o</sup> -	Piece extraction		
-Safety		Gloves, goggles, work clothes and safety shoes.	
-Controls			
1 <sup>o</sup> -	Check the good condition of the machine		
2 <sup>o</sup> -	Check the good condition and placement of the press		
3 <sup>o</sup> -	Check the final curved dimensions of the piece		
-Tests		Not precise	

### Piece 2.1 (Upper Housing)

Table 14: Aluminium curved

Starting material: Plastic pellets

Operation		1 <sup>a</sup>	Injection
-Machine		Plastic injection molding machine	
-Manufacturing		injection work can be carried out by an operator with a minimum category of "2 <sup>nd</sup> Officer"	
-Media Assistant:			
-Supplies		Mold	
-Tools		Not precise	
Development:			
1 <sup>o</sup> -	Placement of the pellets in Plastic injection molding machine		
2 <sup>o</sup> -	Placement of the mold		
3 <sup>o</sup> -	Placement parameters in in Plastic injection molding machine		
4 <sup>o</sup> -	Start-up Plastic injection molding machine		
5 <sup>o</sup> -	Pick up the piece		
-Safety		Gloves, goggles, work clothes and safety shoes.	
-Controls			
1 <sup>o</sup> -	Check the good condition of the machine		
2 <sup>o</sup> -	Check the good condition and placement of the mold		
3 <sup>o</sup> -	Check the parameters of the machine		
4 <sup>o</sup> -	Check the final dimensions of the piece		
-Tests		Every 100 units Resistance and hardness	

Table 15: Upper Housing Injection

#### 4. Measurements and budget

For the preparation of the chapter of MEASUREMENTS AND BUDGET information is required on the times of duration and cost of works, machinery and tooling

##### ESTIMATED TIMES

According to the Technical Office of Methods and Times, the estimated time in each operation is as follows:

Operation: Metal sheet cutting = 0.10h

Operation: Embedding housing = 0.10h

Operation: Cutting leftovers = 0,10h

Operation: Perforated in sheet metal = 0,10h

Operation: End bend = 0.20h

Operation: Rounding of edges with cutter = 0.10h

Operation: Perforated in wood = 0,10h

Operation: Curved in metal = 0.10h

Operation: Plastic injection = 0.10h

Operation: Piece Assembly = 0.20h

##### UNIT COSTS

According to the Commercial Department, the costs of labor and the prices of machinery and tools used, as well as their amortization or useful life, are the following:

##### MATERIAL

Metal sheet Aluminum 70 x 70 x 2 mm = 1.2 kg / u = 5 €

Screw M7x20 = bag 250 units = 10.33 €

Washer M7 = bag 1000 units = € 5.70

Plastic in polypropylene pellets (part 1.1.1 and 2.1) = 1.5 € / Kg

Round stopper for parachute, order of 2000 units approx. € 0.20 / Ud

Solar cells, order of 1000 units, approx. € 7 / unit

## **MACHINERY** (Estimate a use of 2000 h / year)

Shear = € 10,000. Amortization in 20 years.

Column drilling machine = € 1000. Amortization in 15 years. .

Manual portable milling machine = € 150. Amortization in 10 years.

Plastic injection machine = € 30000. Amortization in 10 years.

Curved press = € 4000. Amortization in 10 years.

## **AUXILIARY MEANS**

Press trophy € 1000. Perform 1000 units

Drill 10 €. Life of 100h

Doubled die 200 €. Perform 1000 units

Bench pressure screw 500 €. Life of 20000 h

Concave radius router 15 €. Life of 100h

Molding to bend € 300. Perform 1000 units

Mold for injection (1.1.1) € 5000. Realize 4000 units

Mold for injection (2.1) 3000 €. Realize 4000 units

## **MANUFACTURING**

Official 3rd = € 20 / h

Official 2nd = € 25 / h

Official 1st = € 30 / h

WORK UNIT	MEASUREMENT		DESCRIPTION	UNIT PRICE	AMOUNT (EUROS)	TOTAL (EUROS)
	QUANT.	Ud.				
1.1.1	1	Ud.	Lower Housing			
			<b>Material-</b>			
	0,5	Kg	<b>Plastic pellets</b>	1,5	0,75	
			Works of: Injection			
			<b>Machinerie-</b>			
	0,1	h	Plastic injection machine	1,5	0.15	
			<b>Workforce-</b>			
	0,1	h	2 <sup>a</sup> officer	25	2,5	
			<b>Auxiliary means-</b>			
	0,1	h	Supplies : Mold	1,25	0,125	
			Tools: Not precise			
						3,525€
1.2	4	Ud.	Legs			
			<b>Material-</b>			
	0,21	Kg	<b>Aluminium 70 x 70 x 2 mm</b>	5	1,05	
			Works of: SHEAR			
			<b>Machinerie-</b>			
	0,1	h		0,25	0,025	
			<b>Workforce-</b>			
	0,1	h	3 <sup>a</sup> Officer	20	2	
			<b>Auxiliary means-</b>			
			Supplies : Not precise			
			Tools: Not precise			
			Works of: EDGE SOFTENING			
			<b>Machinerie-</b>			
	0,1	h	Manual portable milling machine	0,0075	0,00075	
			<b>Workforce-</b>			
	0,1	h	2 <sup>a</sup> Officer	25	2,5	
			<b>Auxiliary means-</b>			
	0,1	h	Tools: concave radius cutter	0,15	0,015	
			Supplies: Not precise			

UNIDAD DE OBRA	MEDICIÓN		DESCRIPCIÓN	PRECIO UNITAR	IMPORTE (EUROS)	TOTAL (EUROS)
	CANT.	Ud.				
			Works of: HOLDING			
			<b>Machinery-</b>			
	0,1	h	Column drilling machine	0,034	0,0034	
			<b>Workforce-</b>			
	0,1	h	3 <sup>a</sup> Officer	20	2	
			<b>Auxiliary means-</b>			
	0,1	h	Tools: Metal Drill Ø7,5 mm Supplies: Not precise	0,1	0,01	
			Works of: CURVED			
			<b>Machinery-</b>			
	0,1	h	Curved Press	0,2	0,02	
			<b>Workforce-</b>			
	0,1	h	2 <sup>a</sup> Officer	25	2,5	
			<b>Auxiliary means-</b>			
	0,1	h	Tools: Mold Supplies: Not precise	0,3	0,03	
						10,15€
2.1	1	Ud.	Upper Housing			
			<b>Material-</b>			
	0,2	Kg	Plastic pellets	1,5	0,375	
			Works of: Injection			
			<b>Machinery-</b>			
	0,1	h	Plastic injection machine	1,5	0,15	
			<b>Workforce-</b>			
	0,1	h	2 <sup>a</sup> officer	25	2,5	
			<b>Auxiliary means-</b>			
	0,1	h	Supplies : Mold Tools: Not precise	0,75	0,075	
						3,1€
1.1.2	4	Ud.	Propeller	0,06		0,24€
3	4	Ud.	Tornillo	0,08845		0,35€
4	4	Ud.	Arandelas	0,0087		0,035€
						17,4€

Table 16: Lower Housing Injection

## 5. Activity planning

Next, a planning of the activities for the construction of a DRONE with its corresponding PERT diagram.

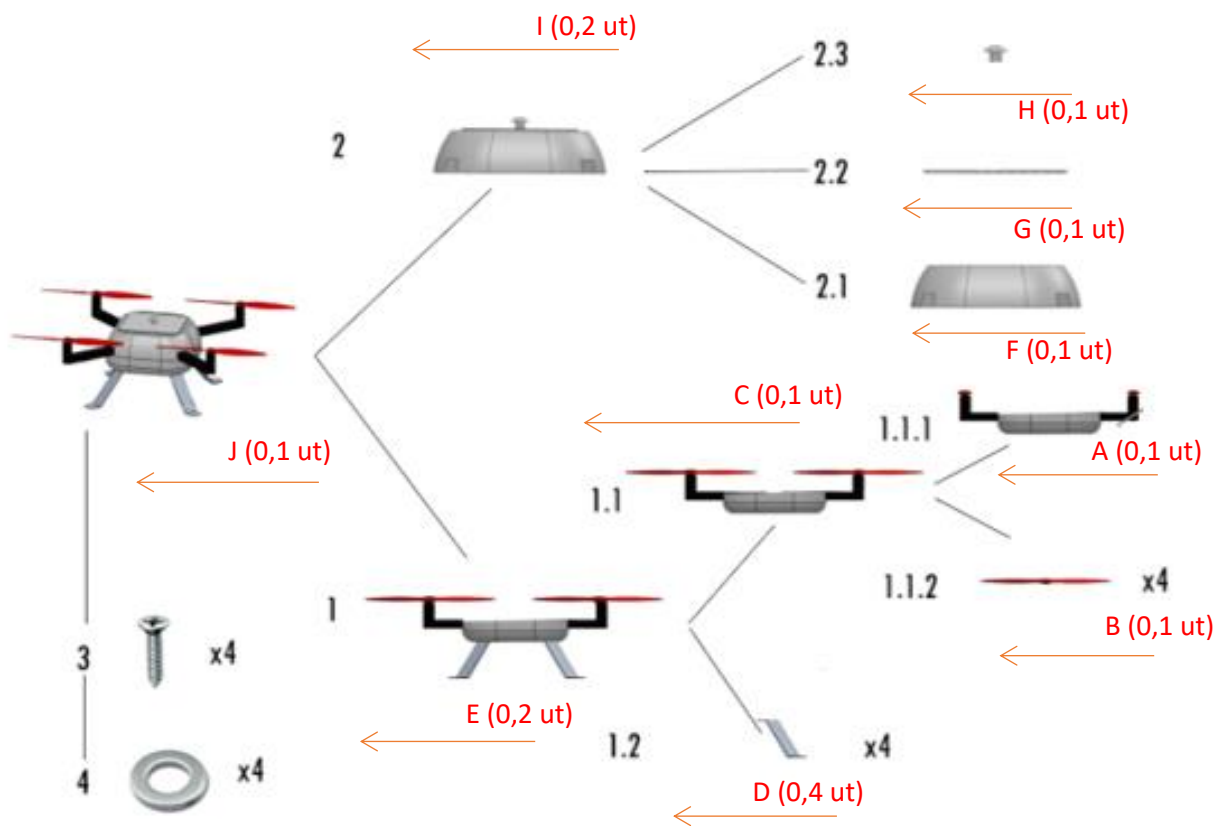


Image 65: Activity Planning

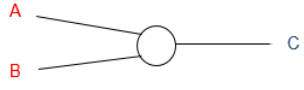
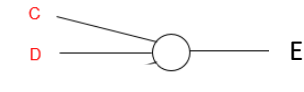
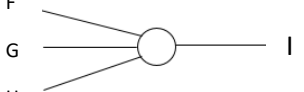
TABLE OF ACTIVITIES FOR THE MANUFACTURE AND ASSEMBLY OF: DRONE						
ELEMENT OR SUBSET	ACTIVITY DESIGNATION	DURATION	PREVIOUS ACTIVITIES	ACTIVITIES IMMEDIATELY PREVIOUS	PARTIAL GRAF	
1.1.1	INJECTION	A1	0,10	-	-	-
1.1.2	(ASK FOR SUPPLY)	B	-	-	-	-
SUB-SET 1.1	ASSEMBLY	C	0,10	A-B	A-B	
1.2	SHEAR ROUNDDING HOLEY CURVED	D1 D2 D3 D4	0,10 0,10 0,10 0,10	-	-	-
SUB-SET 1	ASSEMBLY (SCREW)	E	0,20	A-B	C-D-E	
2.1	INJECTION	F	0,10	-	-	-
2.2	(ASK FOR SUPPLY)	G	-	-	-	-
2.3	(ASK FOR SUPPLY)	H	-	-	-	-
SUB-SET 2	ASSEMBLY	I1	0.20	H-I-J	H-I-J	
SET	USER ASSEMBLY	J	0,10	-	-	-

Table 17: Activity Table

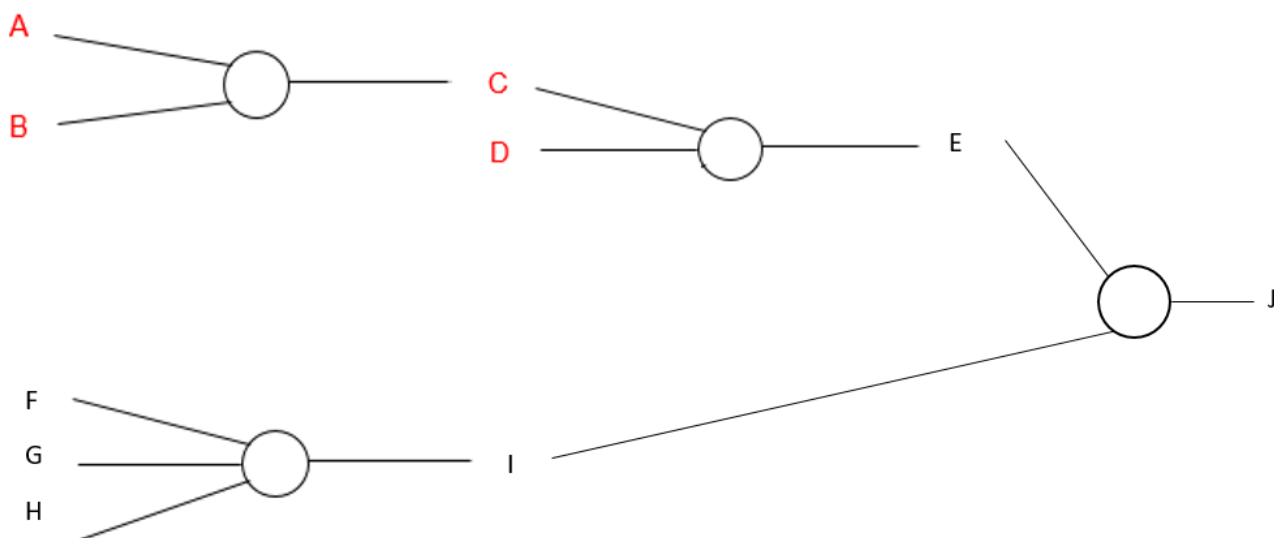


Image 66: Activity diagram

GRAFO SKETCH COMPLETE WITH TIME OF ACTIVITIES

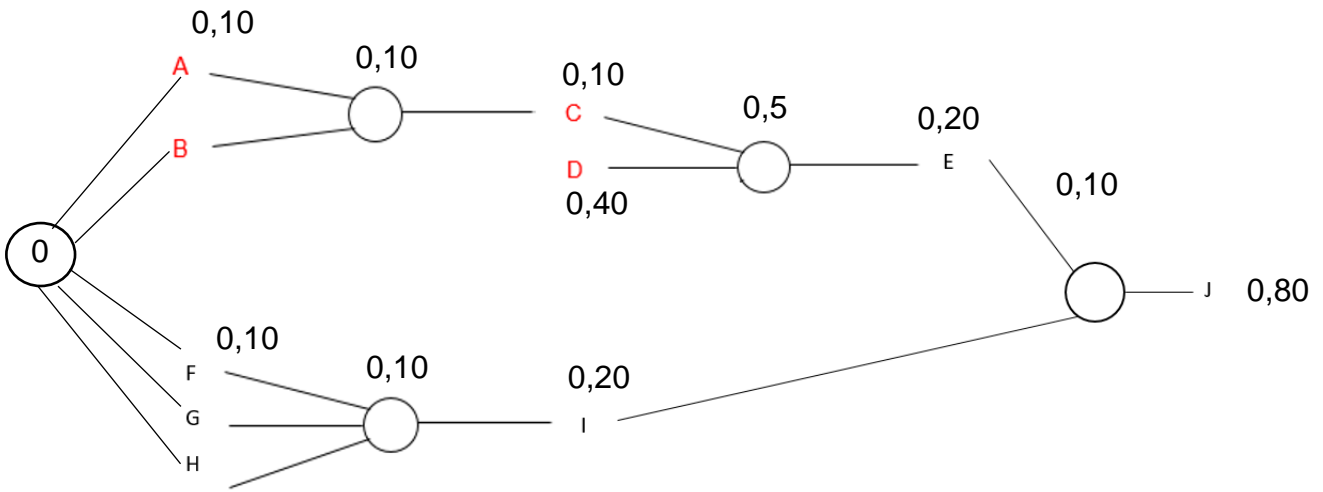


Image 67: Activity Plan with times

INITIAL PERT WITH NUMBER OF OPERATORS

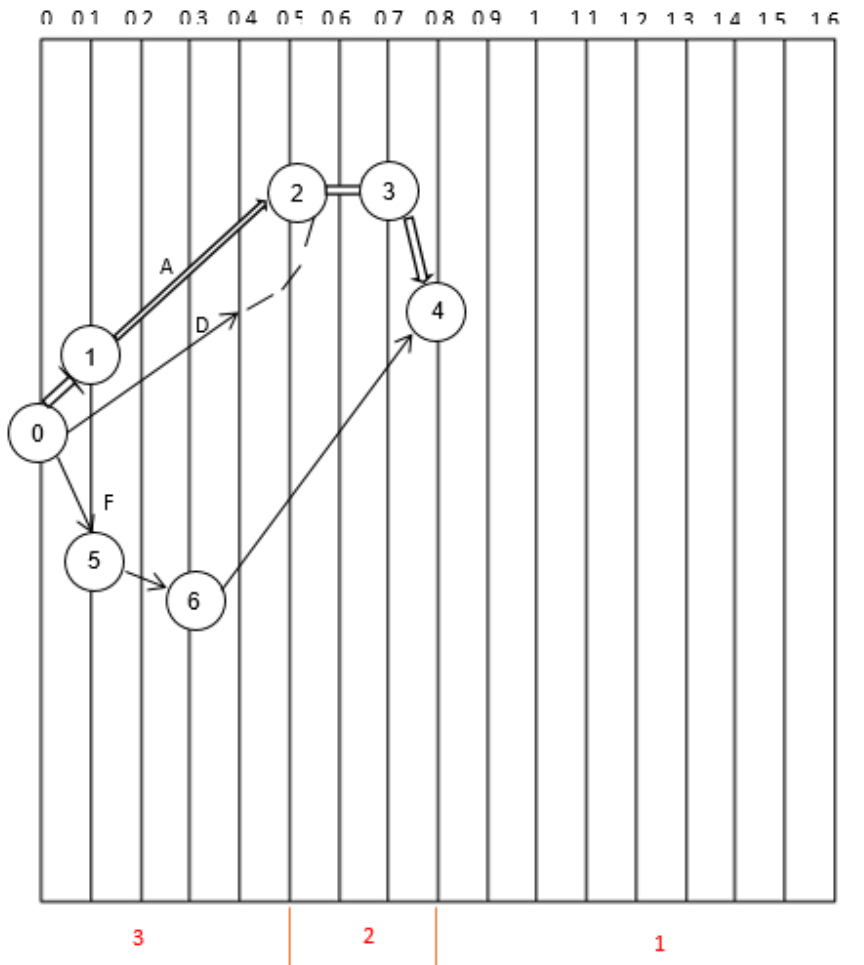


Table 18: Initial Pert



## INITIAL PERT WITH ADJUSTMENT OF NUMBER OF OPERATORS

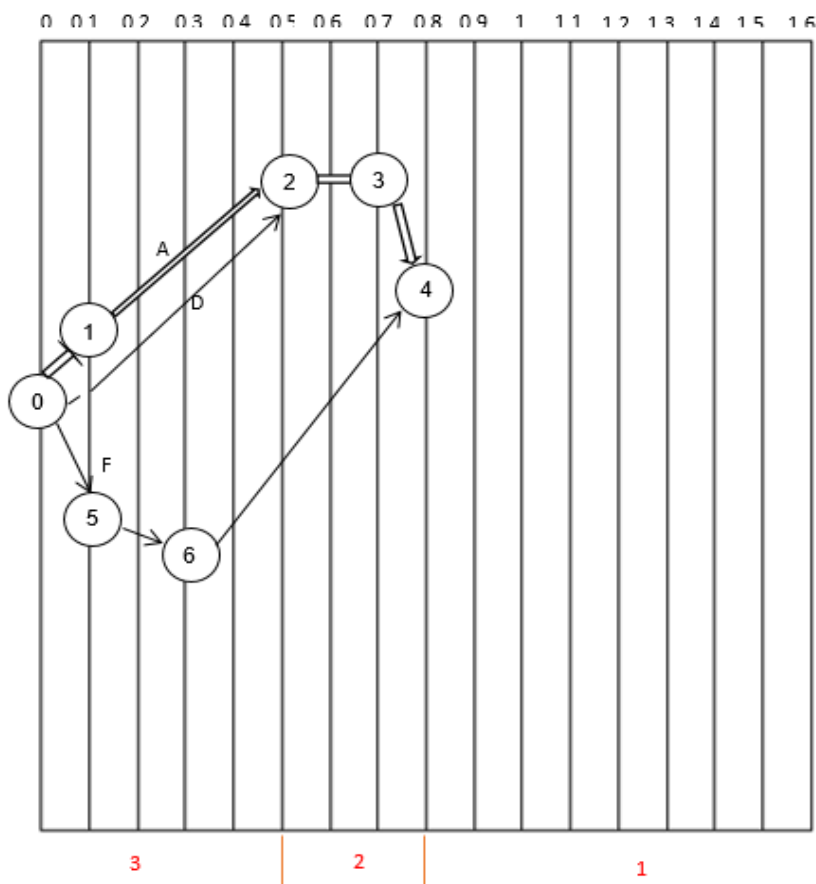


Table 19: Pert with Adjustment

## DECOMPOSITION OF DETAILED ACTIVITIES

ACTIVITIES AND MATERIAL RESOURCES			
ACTIVITY		MACHINE	TIME
INJECTION	A1	INJECTION MACHINE	0,10
ASSEMBLY PROPELLERS (SUB-SET 1.1)	C1	HOOK	0,20
SHEAR	D1	SHEAR	0,10
ROUNDING	D2	MILLING MACHINE	0,10
HOLEY	D3	COLUMN DRILLING	0,10
CURVED	D4	PRESS	0,10
ASSEMBLY LEGS (SUB-SET 1)	E1	SCREW	0,20
INJECTION	F1	INJECTION MACHINE	0,10
ASSEMBLY HOUSINGS (SUB-SET 1)	I	HOOK	0,20
USER ASSEMBLY	J	TOOLS	0,10

Table 20: Descomposition of activities

## **6. DEFINITION PLANS**

### **6.1 JOINT PLANS**

Plans of set, in orthogonal projection, with marks of elements, general dimensions and list of elements

### **6.2 SUBCONJUNT PLANS**

Drawings of all subsets with functional dimension.

### **6.3 EXPLODED PLANS**

Drawings of all the component elements with functional dimension.

### **6.4 PLANT DISTRIBUTION**

In these planes the route of the operator that makes the elements (1.1.1, 1.2 and 2.1) in the industrial warehouse will be shown

### **6.5 LUMINARY PLANT DISTRIBUTION**

Next, the electrical system of the ship is developed to check its installation.

### **6.6 EMERGENCY PLANT DISTRIBUTION**

Finally, a safety set is designed to avoid accidents inside the ship itself.

## Bibliography

<https://www.ebsco.com/drone> <sup>1</sup>

<http://droneymas.es/partes-de-un-drone/> <sup>2</sup>

<http://www.eis.uva.es/~biopolimeros/alberto/pla.htm> <sup>3</sup>

<https://www.impresoras3d.com/el-material-de-impresion-abs-y-sus-caracteristicas/> <sup>4</sup>

<https://www.impresoras3d.com/filamento-pla-consejos-caracteristicas-y-muchomas/> <sup>5</sup>

<http://www.petroquim.cl/que-es-el-polipropileno/> <sup>6</sup>

<http://blogs.repsol.com/innovacion/polietileno-un-plastico-muy-resistente-con-gran-variedad-de-aplicaciones/> <sup>7</sup>

<https://uadedrones.wordpress.com/2015/09/22/simulacin-de-empuje-de-la-hlice-con-cfd/> <sup>8</sup>

<http://noticiasdelaciencia.com/not/12949/actuaciones-en-vuelo-de-drones/> <sup>9</sup>

<http://www.profesorenlinea.cl/fisica/PresionAtmosferica.htm> <sup>10</sup>

<http://www.aenor.es/aenor/actualidad/actualidad/noticias.asp?campo=1&codigo=44924> <sup>11</sup>

<http://fpvmax.com/2017/04/10/normas-iso-drones/> <sup>12</sup>

<http://www.extrusax.com/imagenes/descargas/es/12/STANDARD%20PROFILE%20-%20PERFILES%20NORMALIZADOS.pdf> <sup>13</sup>

<http://www.echebarriasuministros.com/images/catalogo/13-tornilleria-y-remaches.pdf> <sup>14</sup>

<file:///C:/Users/Jordi/Desktop/TECHNO-SUN-catalogo-productos-energia-solar.pdf> <sup>15</sup>

[https://kem.com.mx/kem\\_txt\\_src.php?input\\_txt\\_src=capuchones&btn\\_txt\\_src](https://kem.com.mx/kem_txt_src.php?input_txt_src=capuchones&btn_txt_src) <sup>16</sup>

[http://www.osg.com.br/v4/fotos/download/Cat\\_Brocas\\_Low2014.pdf](http://www.osg.com.br/v4/fotos/download/Cat_Brocas_Low2014.pdf) <sup>17</sup>

[https://www.amazon.es/STANLEY-1-65-412-Destornillador-aislado-FatMax/dp/B001E4IIPK/ref=sr\\_1\\_50?s=tools&ie=UTF8&qid=1528282582&sr=1-50](https://www.amazon.es/STANLEY-1-65-412-Destornillador-aislado-FatMax/dp/B001E4IIPK/ref=sr_1_50?s=tools&ie=UTF8&qid=1528282582&sr=1-50) <sup>18</sup>

<https://filament2print.com/es/nylons/641-nylon-taulman-230.html> <sup>19</sup>

<https://www.3dnatives.com/es/3D-compare/imprimante/zortrax-m200> <sup>20</sup>

<https://www.colorplus3d.com/producto/filamento-3d-especial-fibra-de-carbono/> <sup>21</sup>

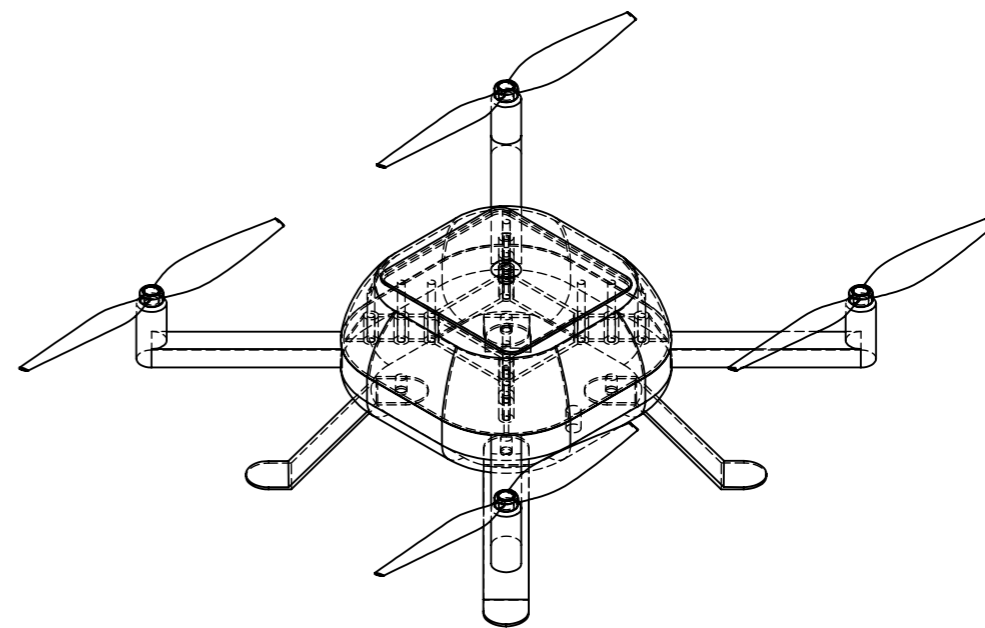
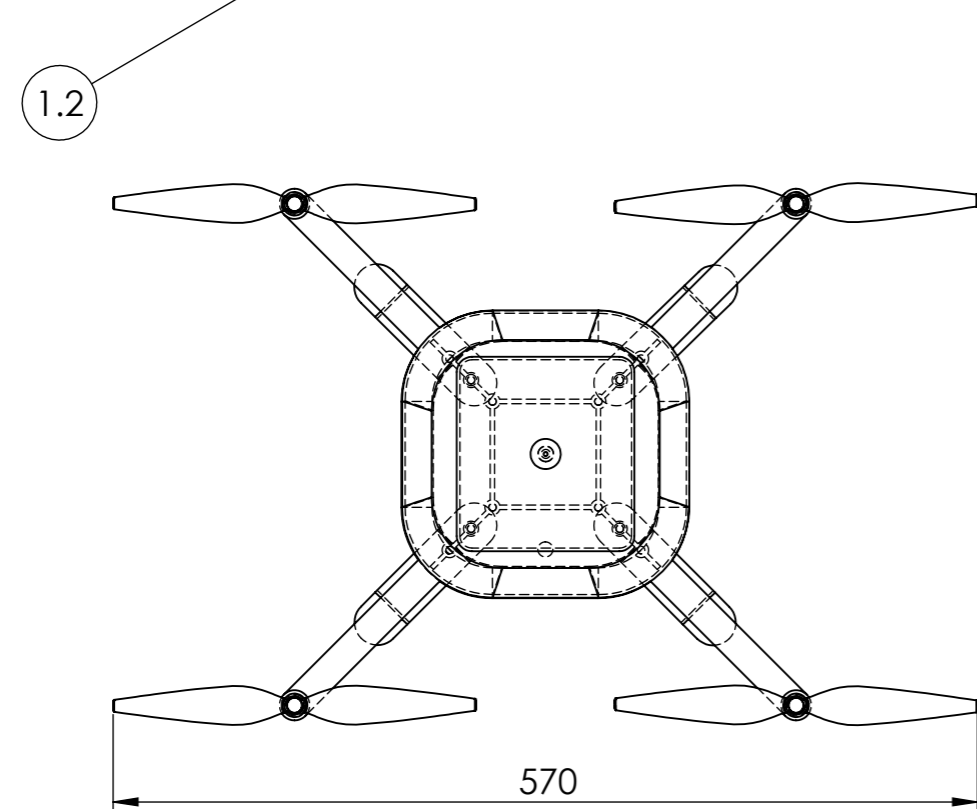
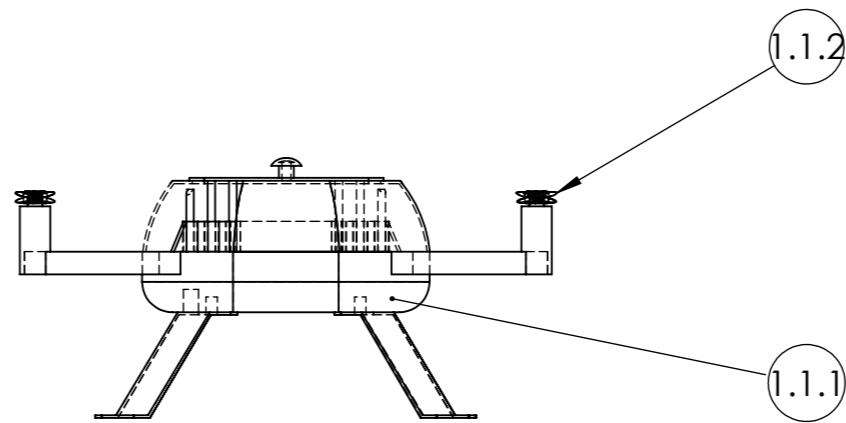
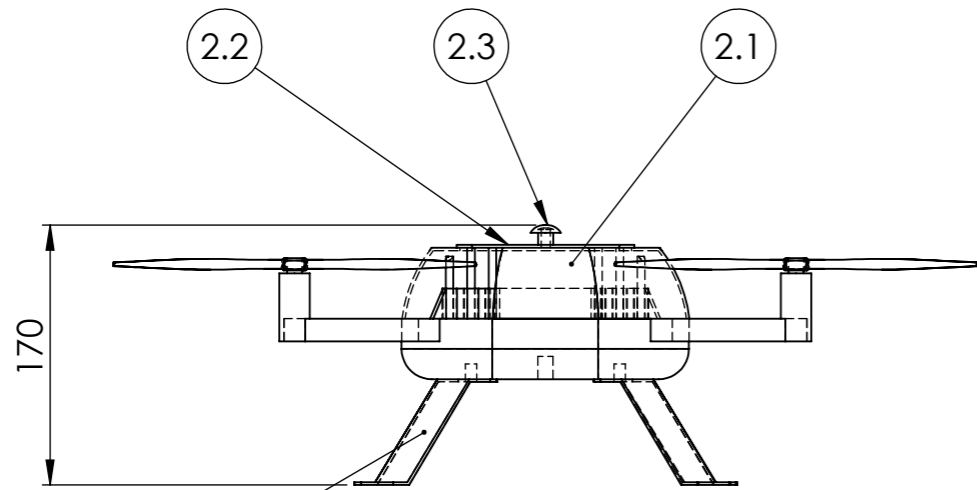


UNIVERSITAT  
POLITÈCNICA  
DE VALÈNCIA

CAMPUS D'ALCOI

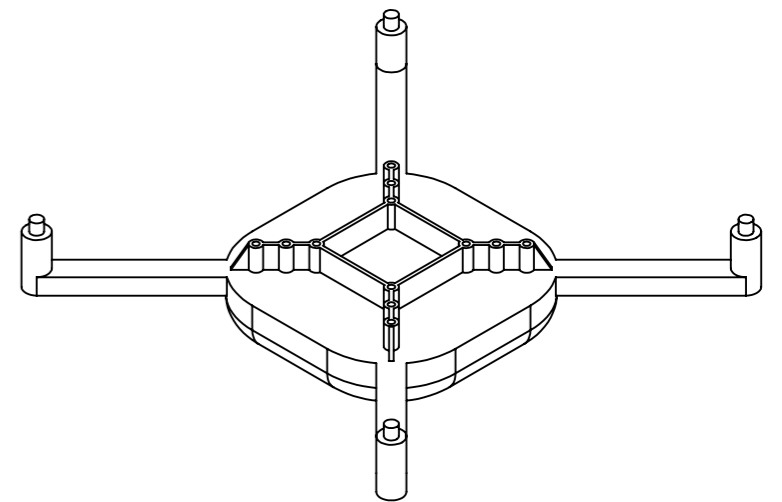
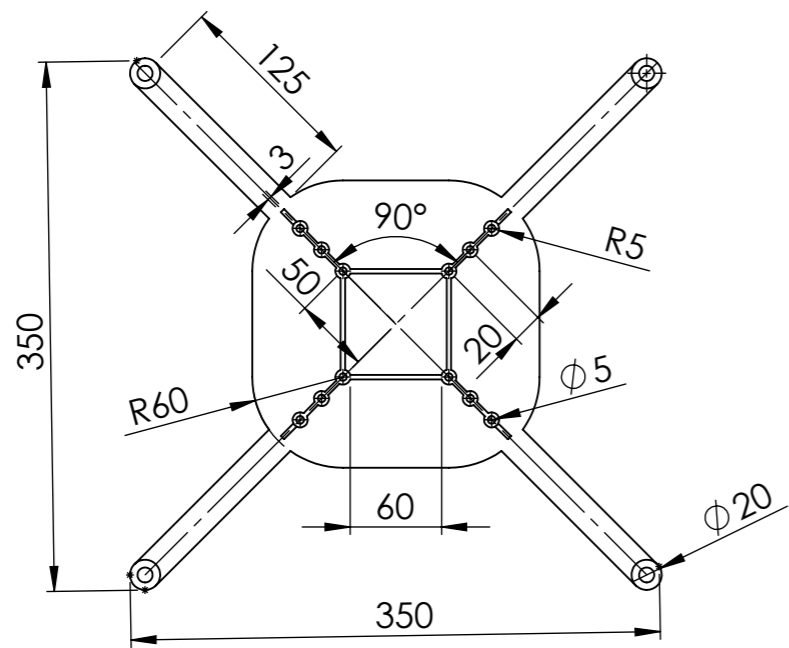
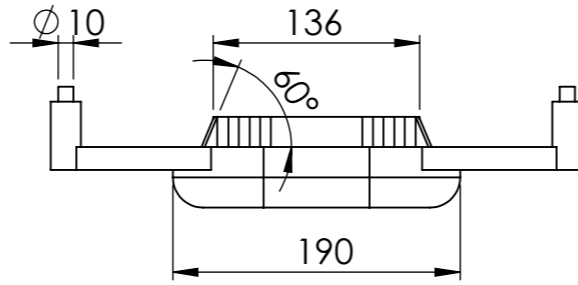
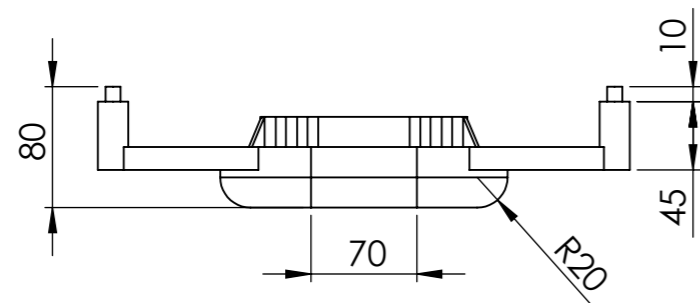


Uniwersytet Technologiczno-Przyrodniczy  
Im. Jana i Jędrzeja Śniadeckich w Bydgoszczy

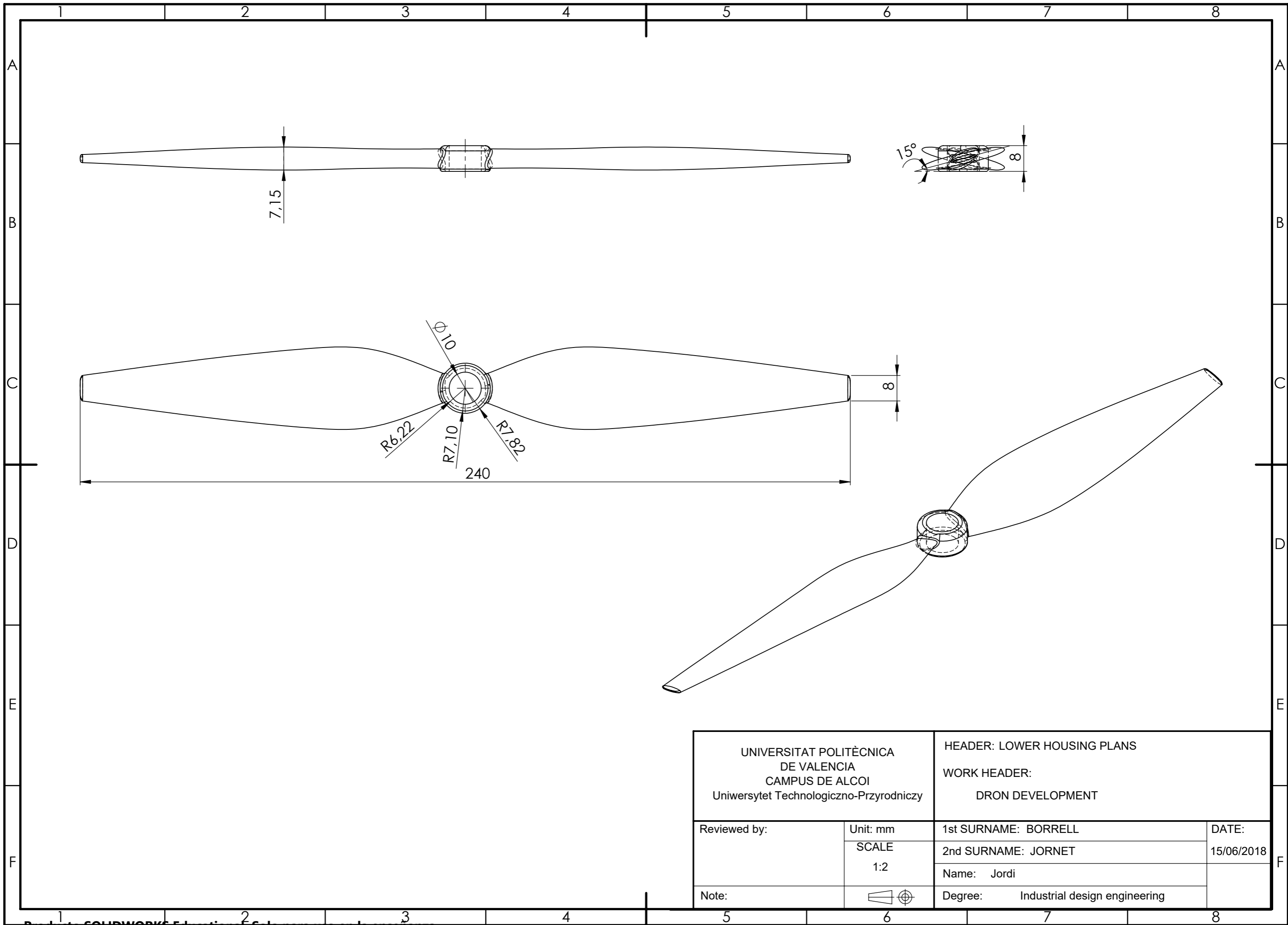



2.3	PIVOT	1	SEE ANNEX	POPLYPROPILENE
2.2	SOLAR CELL	1	SEE ANNEX	-
2.1	UPPER HOUSING	1	SEE ANNEX	POPLYPROPILENE
1.2	LEG	4	SEE ANNEX	ALUMINIUM
1.1.2	PROPELLER	4	SEE ANNEX	CARBON FIBER
1.1.1	LOWER HOUSING	1	SEE ANNEX	POPLYPROPILENE
MARK	DESIGNATION	QUANTITY	REFERENCE	MATERIAL

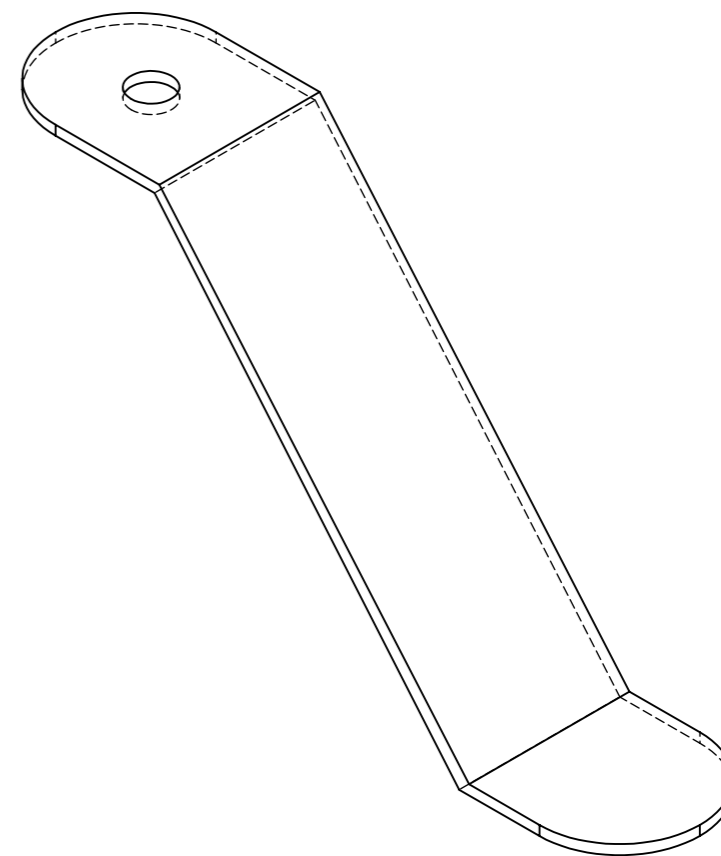
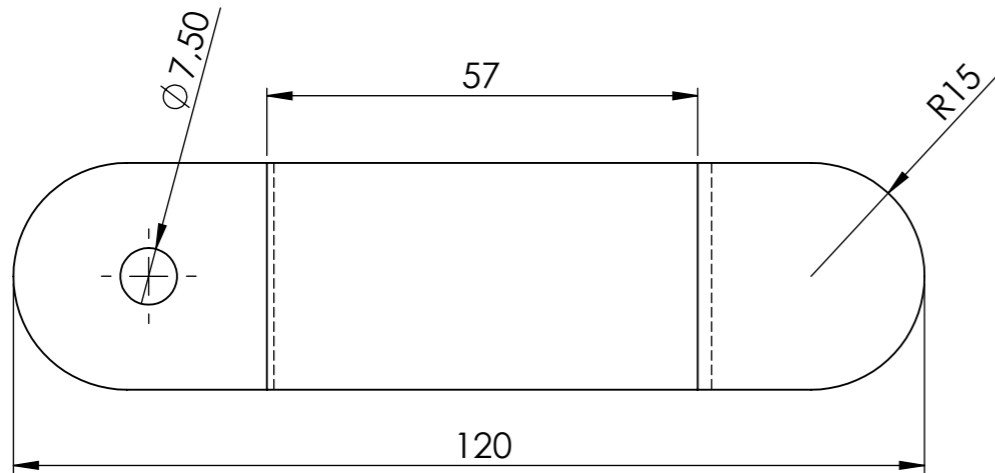
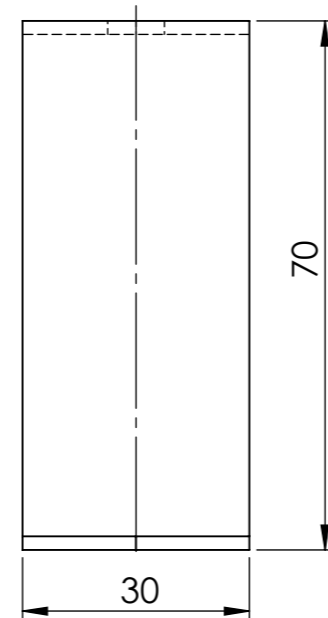
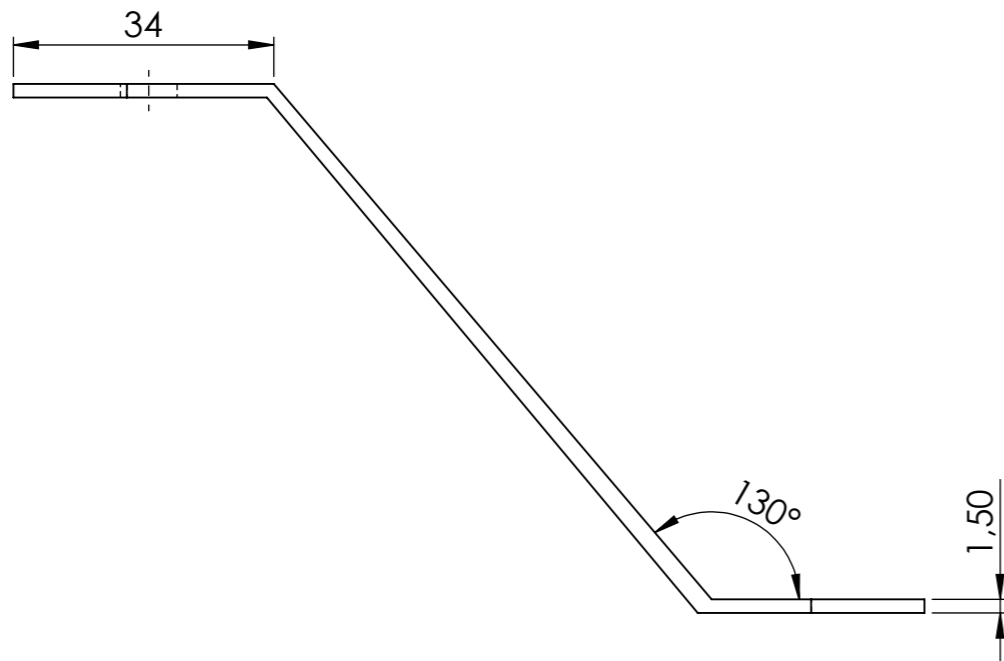
UNIVERSITAT POLITÈCNICA DE VALENCIA CAMPUS DE ALCOI Uniwersytet Technologiczno-Przyrodniczy		HEADER: DRONE SET	
		WORK HEADER: DRON DEVELOPMENT	
Reviewed by:	Unit: mm	1st SURNAME: BORRELL	DATE:
	SCALE 1:5	2nd SURNAME: JORNET	15/06/2018
Note:		Name: Jordi	
		Degree: Industrial design engineering	



UNIVERSITAT POLITÈCNICA DE VALENCIA CAMPUS DE ALCOI Uniwersytet Technologiczno-Przyrodniczy		HEADER: LOWER HOUSING PLANS  WORK HEADER: DRON DEVELOPMENT	
Reviewed by:	Unit: mm	1st SURNAME: BORRELL	DATE:
	SCALE 1:5	2nd SURNAME: JORNET	15/06/2018
Note:		Name: Jordi	
		Degree: Industrial design engineering	

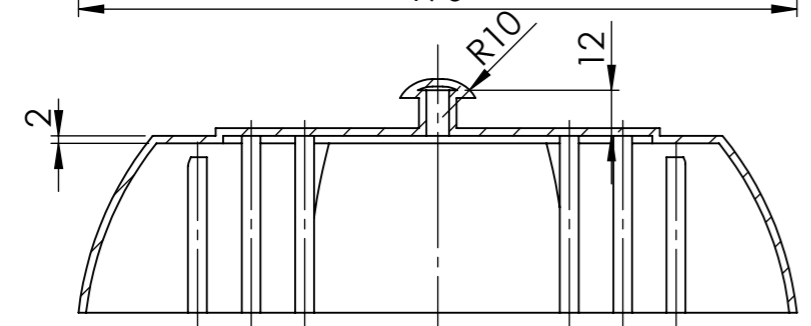
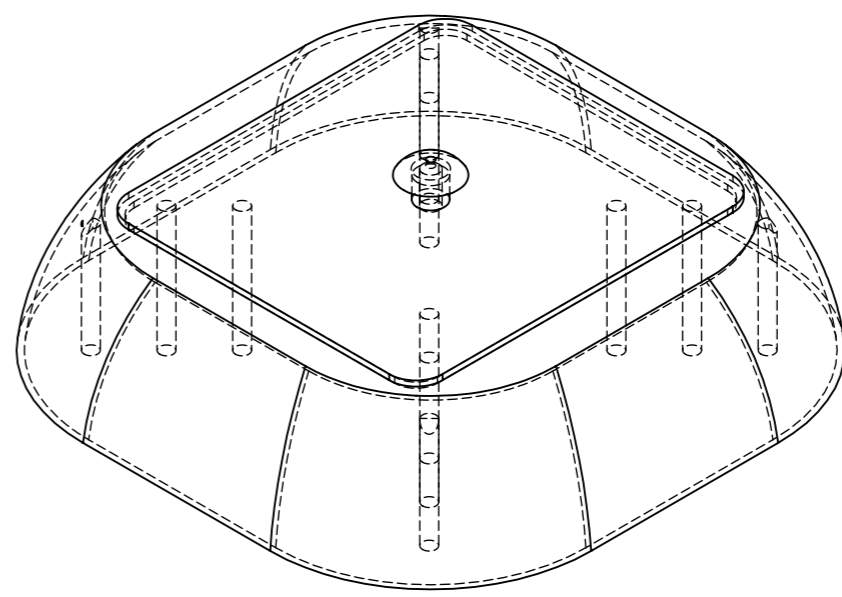
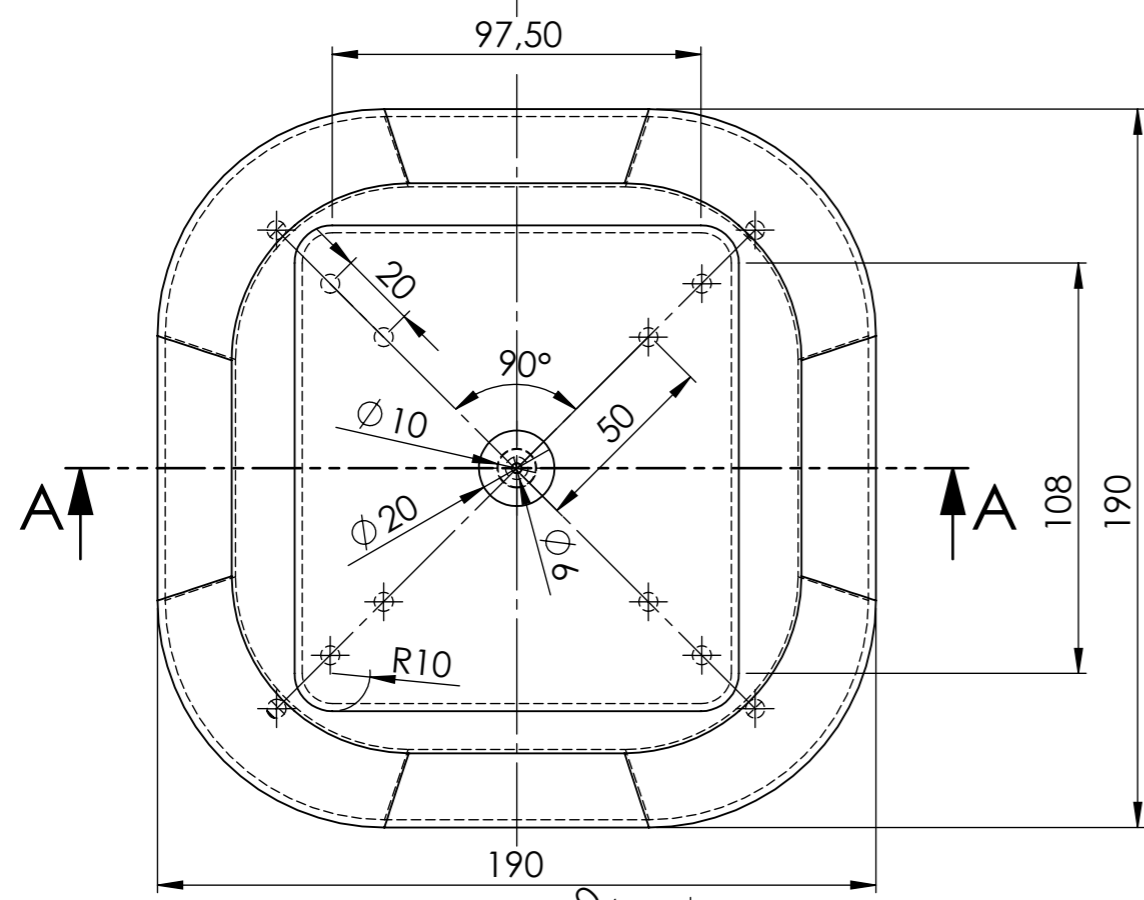
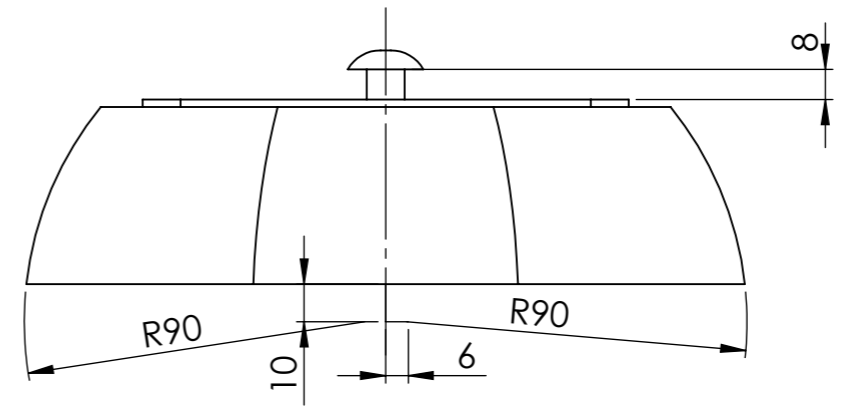
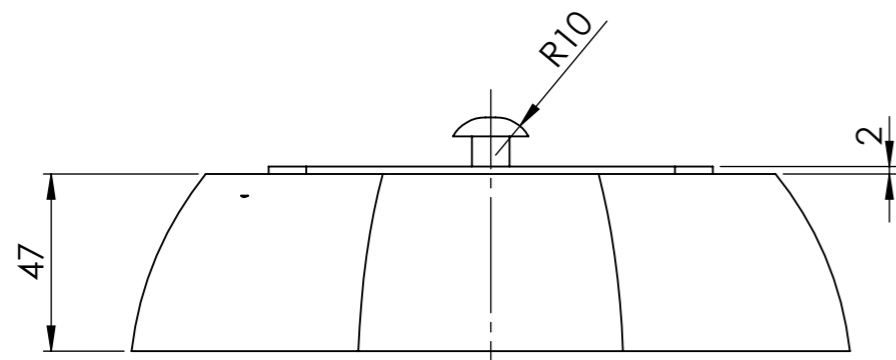


UNIVERSITAT POLITÈCNICA DE VALENCIA CAMPUS DE ALCOI Uniwersytet Technologiczno-Przyrodniczy		HEADER: LOWER HOUSING PLANS	
		WORK HEADER: DRON DEVELOPMENT	
Reviewed by:	Unit: mm	1st SURNAME: BORRELL	DATE:
	SCALE 1:2	2nd SURNAME: JORNET	15/06/2018
Note:		Name: Jordi	
		Degree: Industrial design engineering	



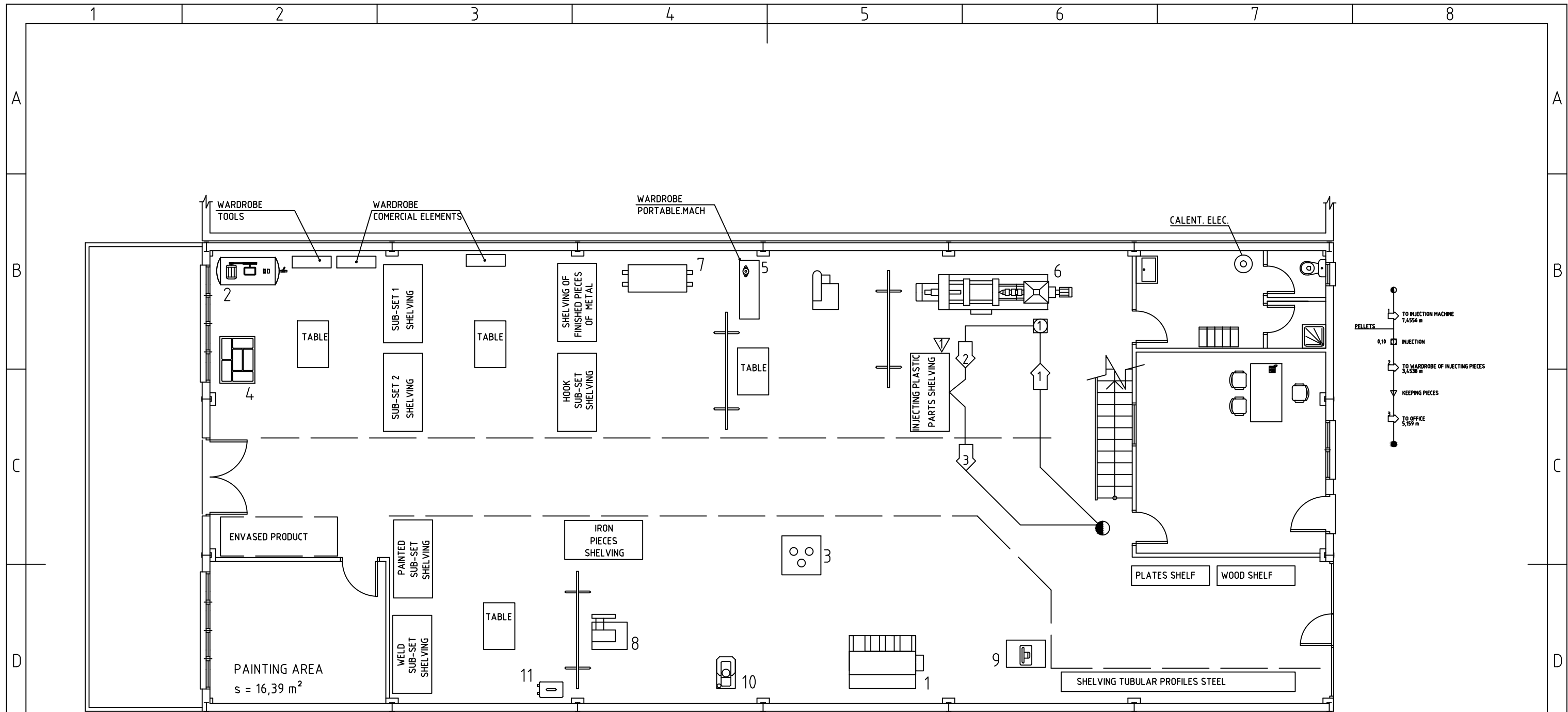
UNIVERSITAT POLITÈCNICA DE VALENCIA CAMPUS DE ALCOI Uniwersytet Technologiczno-Przyrodniczy		HEADER: LEG PLANS	
		WORK HEADER: DRON DEVELOPMENT	
Reviewed by:	Unit: mm	1st SURNAME: BORRELL	DATE:
	SCALE 1:1	2nd SURNAME: JORNET	15/06/2018
Note:		Name: Jordi	
		Degree: Industrial design engineering	





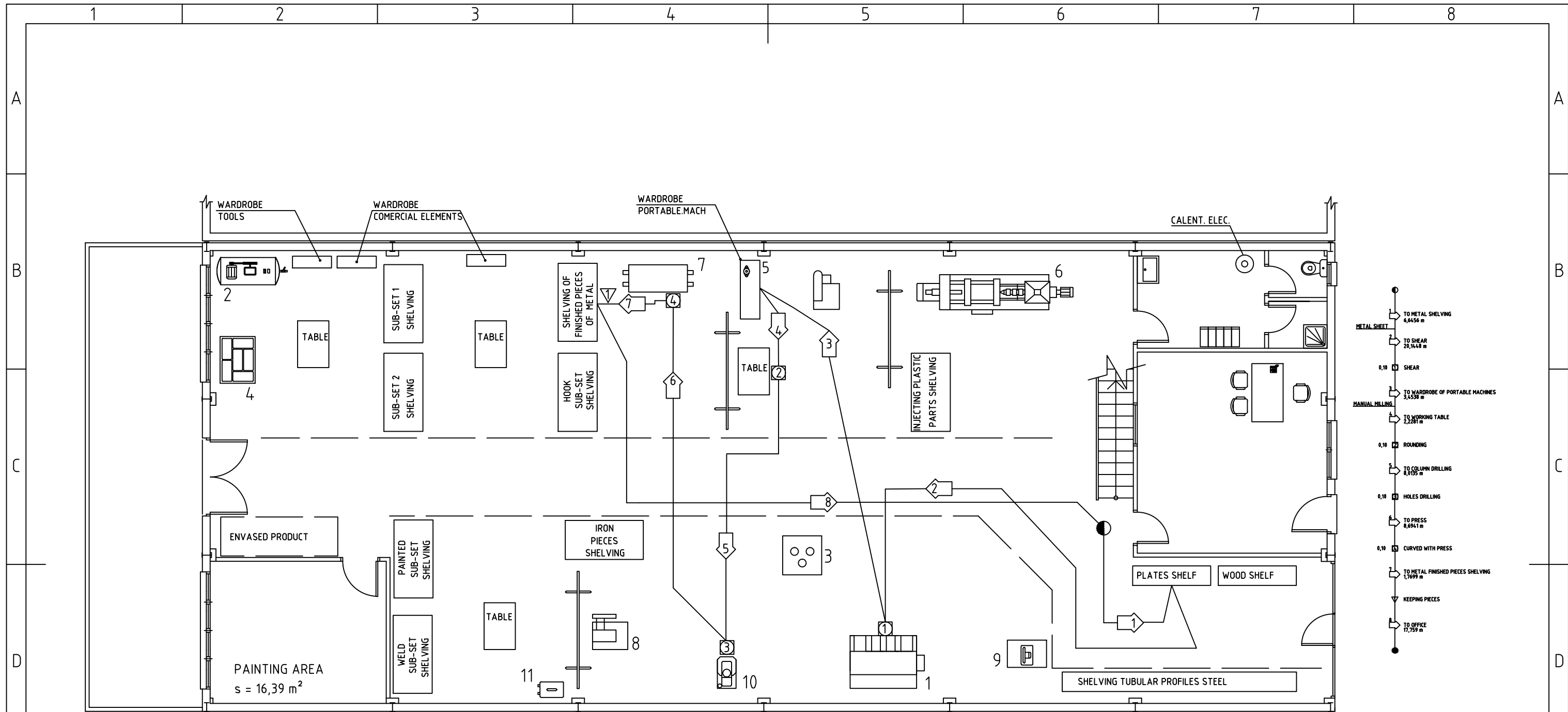
SECCIÓN A-A

UNIVERSITAT POLITÈCNICA DE VALENCIA CAMPUS DE ALCOI Uniwersytet Technologiczno-Przyrodniczy		HEADER: UPPER HOUSING PLANS  WORK HEADER: DRON DEVELOPMENT	
Reviewed by:	Unit: mm	1st SURNAME: BORRELL	DATE:
	SCALE 1:2	2nd SURNAME: JORNET	15/06/2018
Note:		Name: Jordi	
		Degree: Industrial design engineering	



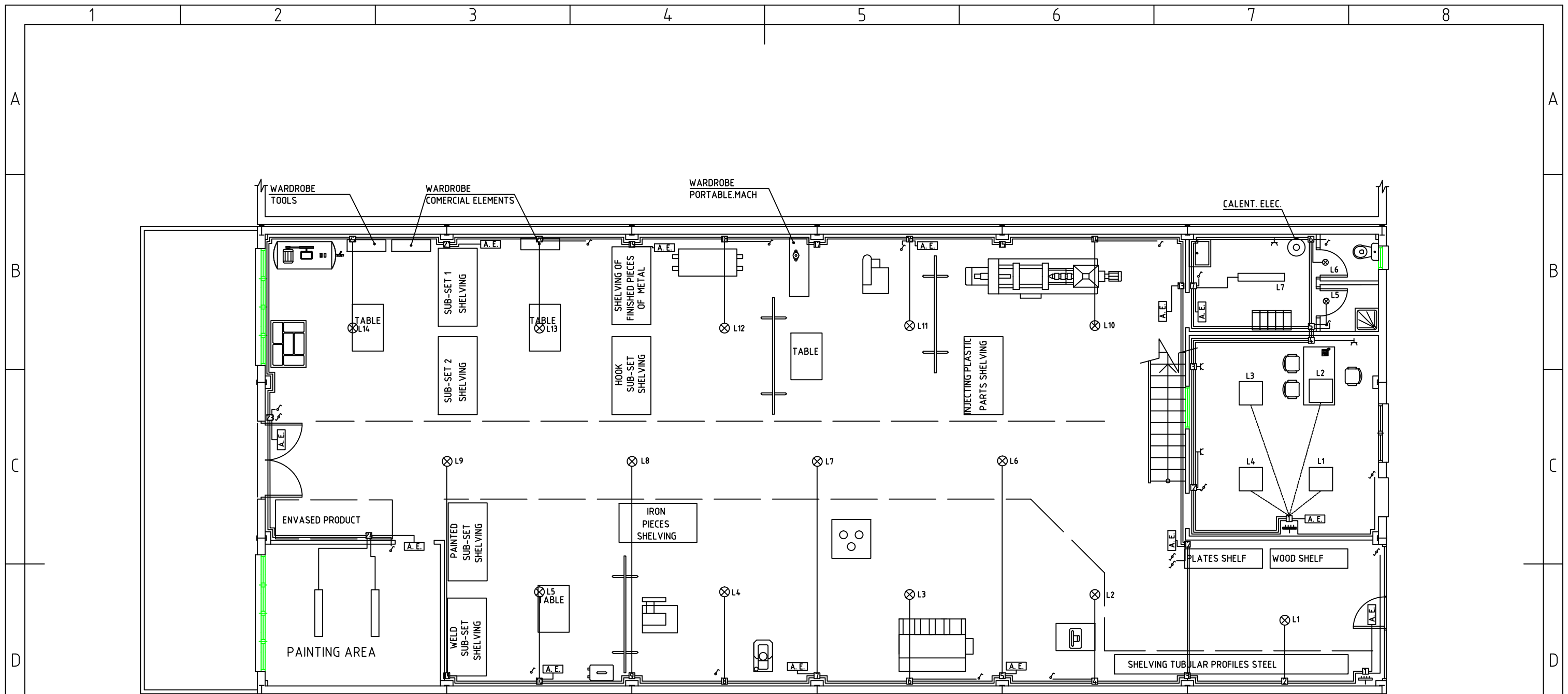
11	Cutting machine with table
10	Column Drilling
9	Band Saw
8	Mechanic Press 60 t
7	Curved Press
6	Inyplast
5	Manual portable Milling
4	Welding equipment
3	Pibe curved
2	Compressor
1	Shear
Nº	MACHINE

		TITLE OF THE WORK:	
		OPERATOR'S PATH 1.1.1 & 2.1 PIECES	
		TITLE OF THE DRAW: PLANT DISTRIBUTION	
REVISION Nº:	UNITY: mm	PROPERTY:	Nº de registry:
DATE:	SCALE	JORDI BORRELL JORNET	PAPER:
DATE:	1:100	Made by:	REVISION:
FORMAT:			



11	Cutting machine with table
10	Column Drilling
9	Band Saw
8	Mechanic Press 60 t
7	Curved Press
6	Inyplast
5	Manual portable Milling
4	Welding equipment
3	Pibe curved
2	Compressor
1	Shear
Nº	MACHINE

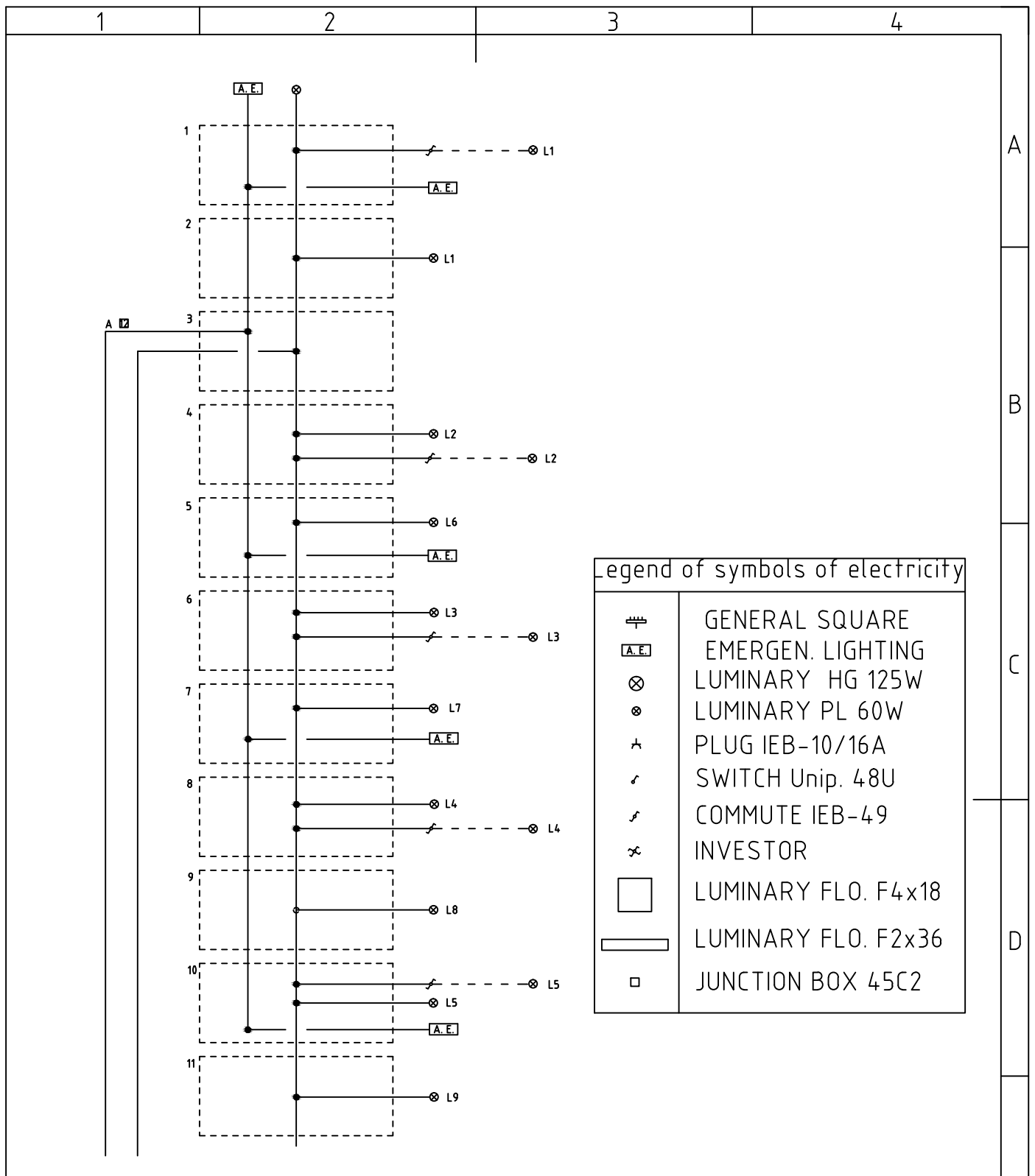
		TITLE OF THE WORK:	
		OPERATOR'S PATH 1.2 PIECE	
		TITLE OF THE DRAW: PLANT DISTRIBUTION	
REVISION Nº:	UNITY: mm	PROPERTY:	Nº de registry:
DATE:	SCALE	JORDI BORRELL JORNET	PAPER:
DATE:	1:100	Made by:	REVISION:
FORMAT:			



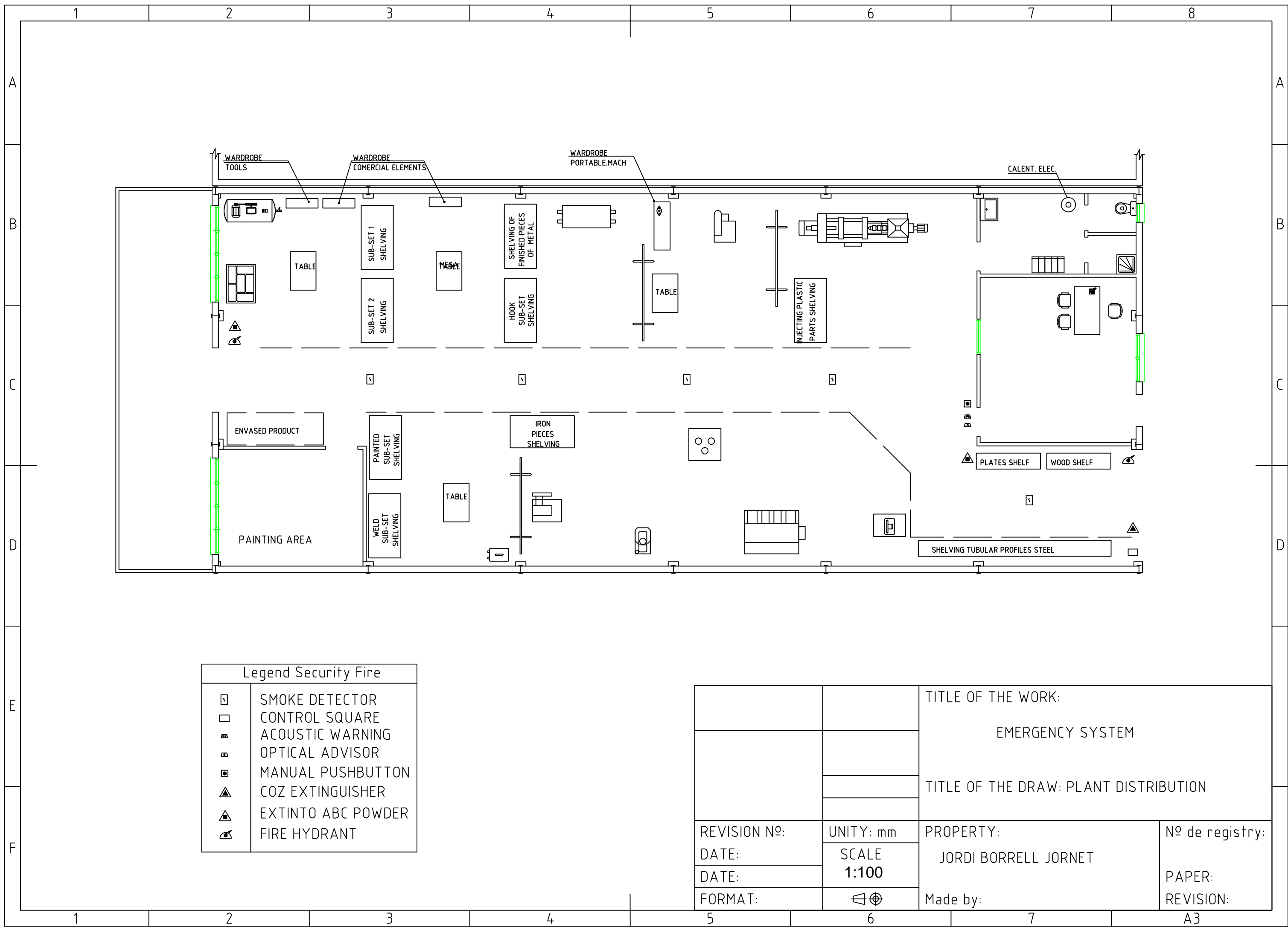
Legend of symbols of electricity

	GENERAL SQUARE
	EMERGEN. LIGHTING
	LUMINARY HG 125W
	LUMINARY PL 60W
	PLUG IEB-10/16A
	SWITCH Unip. 48U
	COMMUTE IEB-49
	INVESTOR
	LUMINARY FLO. F4x18
	LUMINARY FLO. F2x36
	JUNCTION BOX 45C2

		TITLE OF THE WORK:	
		LUMINARY SYSTEM	
		TITLE OF THE DRAW: PLANT DISTRIBUTION	
REVISION Nº:	UNITY: mm	PROPERTY:	Nº de registry:
DATE:	SCALE	JORDI BORRELL JORNET	PAPER:
DATE:	1:100	Made by:	REVISION:
FORMAT:			



		TITLE OF THE WORK:	
		LUMINARY SYSTEM	
		TITLE OF THE DRAW: PLANT DISTRIBUTION	
REVISION Nº:	UNITY: mm	PROPERTY:	Nº de registry:
DATE:	SCALE	JORDI BORRELL JORNET	PAPER:
DATE:	1:100	Made by:	REVISION:
FORMAT:			



Legend Security Fire	
	SMOKE DETECTOR
	CONTROL SQUARE
	ACOUSTIC WARNING
	OPTICAL ADVISOR
	MANUAL PUSHBUTTON
	COZ EXTINGUISHER
	EXTINTO ABC POWDER
	FIRE HYDRANT

		TITLE OF THE WORK: EMERGENCY SYSTEM	
		TITLE OF THE DRAW: PLANT DISTRIBUTION	
REVISION Nº:	UNITY: mm	PROPERTY:	Nº de registry:
DATE:	SCALE 1:100	JORDI BORRELL JORNET	
DATE:			
FORMAT:		Made by:	PAPER: REVISION: