

## Push-out tests on embedded shear connections for hybrid girders with trapezoidal web

B. Jáger<sup>a\*</sup>, G. Németh<sup>a</sup>, N. Kovács<sup>a</sup>, B. Kövesdi<sup>a</sup>, M. Kachichian<sup>a</sup>

<sup>a</sup>Department of Structural Engineering, Budapest University of Technology and Economics, Hungary

\*corresponding author, e-mail address: [jager.bence@epito.bme.hu](mailto:jager.bence@epito.bme.hu)

---

### Abstract

Hybrid girders with corrugated web are increasingly used in bridge engineering due to its numerous favorable properties. For the web-to-slab connection different layouts have been developed in the past, however, just a few design proposals can be found in the international literature for the determination of the connection's resistance, especially for the embedded types. In case of these connections the corrugated web is simply embedded into the concrete slab strengthened by transverse rebars through concrete dowels or horizontal headed studs welded to the web. The aim of the current research program is to investigate the structural behavior and the shear capacity of embedded connections by full scale push-out tests. In the current paper the results of 5 push-out tests are introduced having different embedded connection types investigating (i) the effect of the embedding depth, (ii) the existence of the concrete dowels (through cut-outs in the steel web) with transverse rebars and (iii) the influence of the steel flange. These parameters may have significant influence on the behavior and capacity of embedded type connections, which are studied in the research program. During the tests the applied load and the slip between the steel web and concrete slabs are measured in order to study the initial stiffness, the ductility and the shear capacity of the connections.

**Keywords:** *shear connector; trapezoidal web; hybrid girder; embedded connection; corrugated perfobond; headed stud.*

---

### 1. Introduction

Steel corrugated webs are increasingly used in bridge decks with double composite action having the lower and upper flanges made of concrete. In the literature this layout is called as hybrid girder with corrugated web. There are different types of solutions how to construct the connection between the concrete slabs and the steel corrugated web. The choice depends mainly on the construction method and on the longitudinal shear and out-of-plane bending resistances. Different shear connectors found in the international literature are presented in Fig. 1. The most commonly used shear connectors are the headed studs welded onto the outer side of the steel flanges shown in Fig. 1a. Other existing connection layouts are presented in Fig. 1b-d having steel flanges. In these connection layouts combined single perfobond and headed studs, double perfobond and angle connectors are applied with transverse and/or

longitudinal rebars. In Fig. 1e an embedded type connection layout is presented. Despite of its wide range application, there are, however, just a few number of available research results and proposals on the determination of the resistances of the embedded connections.

The EN 1994-1-1 [1] standard provides only design resistance model for connections with headed studs placed on the external side of the steel flanges. In addition standardized push-out test arrangement and evaluation are provided in the EN 1994-1-1 Annex B [1] if different connection layouts would be applied. However, design model or necessary test arrangements are not provided for innovative shear connections.

The embedded type connections have been started to be investigated by Nakasu et al. [2] in 2000. They studied the out-of-plane bending resistance of embedded connections with experimental tests and FE analysis. In 2006 Kosa

et al. [3] studied the behavior of hybrid beams with corrugated webs. They observed that the damage of the connection occurred by gap appearance between the steel web and concrete flanges. In 2008 Shiji et al. [4] carried out push-out tests with new type of connection applicable in the lower slab. In this layout vertical perforated plate connectors are welded to the corrugated web and to the inner side of the lower steel flange, thus the concrete slab is placed to the inner side of the web improving the water proofing of the connection. In 2009 Taira et al. [5] performed FE analysis on the stress distributions and stress concentrations in the concrete slab around the embedded joint in particular to the effect of the welded splice of corrugated steel web. Novák and Röhm [6] executed a comprehensive research including experimental push-out tests and FE analysis on the shear capacity of embedded type connections in 2009. Based on their results a design proposal was developed for the determination of the shear capacity of embedded type connections with transverse rebars. The out-of-plane bending moment resistance of those connections was experimentally studied by Röhm and Novák [7] in 2010.

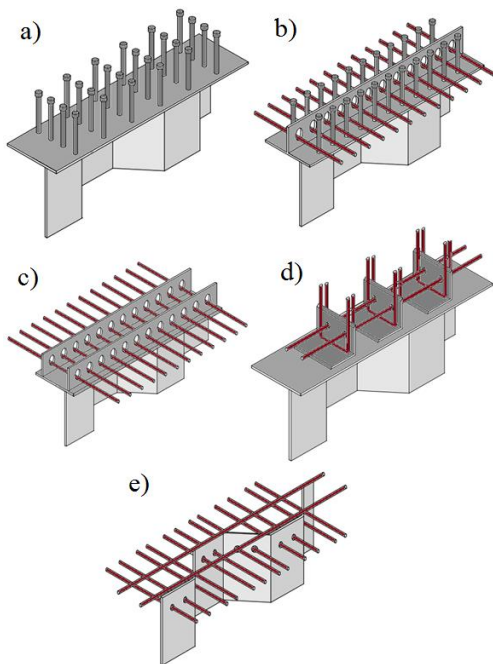

Fig. 1. Connection layouts.

Corrugated perfobond type connectors welded to the outer side of steel flanges were experimentally studied by push-out tests by Kim et al. [8] in 2011. Based on the results new proposal was developed for the determination of

the shear capacity of corrugated perfobond type connections with transverse rebars. Embedded corrugated web connections with horizontal headed studs were investigated by Raichle and Kuhlmann [9] in 2015. Their research aims were to study the shear capacity and the out-of-plane bending capacity of the investigated shear connectors by experimental push-out tests and advanced FE analysis. Based on their results resistance model is developed for the determination of the shear capacity and the out-of-plane bending capacity of embedded corrugated web connections using vertical headed studs. In 2018 Wang et al. [10] conducted experimental push-out tests and FE analysis on the shear capacity of perforated plate connectors welded to the inner side of the steel flange and corrugated web (studied first by Shiji et al. [4]). Based on a comprehensive research program a simplified proposal was developed for the calculation of the shear capacity.

Based on the literature review the lack of experiences and results have been found in the field of resistance and stiffness of embedded shear connections of corrugated hybrid girders. To contribute to this research an extensive experimental test series have been designed including a total number of 56 specimens with a wide range of structural details to investigate the structural behavior of this connection type. In this paper we are focusing on the results of 5 experimental tests of the same kind to investigate the behavior and resistance to longitudinal shear of embedded type connections with concrete dowels and transverse rebars. The used notations are shown in Fig. 2.

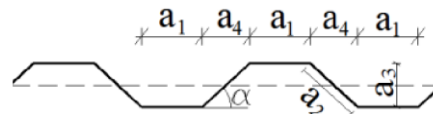

Fig. 2. Used notations.

## 2. Design proposals for shear capacity

In the international literature there are only two available proposals for the determination of the shear capacity of embedded type connections having transverse rebars or horizontal headed studs. According to Novák and Röhm [6] the shear resistance of the embedded type connection with transverse rebars through concrete dowels can be calculated by Eq. (1).

$$P_{Rd,L,NR} = \frac{1}{2 * L_w * \gamma_v} (h a_3)^{0.15} t_w^{0.55} t_E^{0.35} f_{ck}^{0.45} a_s^{0.1} (1 + \mu)^{1.5} \quad (1)$$

where  $L_w$  is the profile length of one corrugation wave ( $2a_1+2a_4$ ),  $h$  is the thickness of the concrete slab,  $a_3$  is the corrugation depth (see Fig. 2),  $t_w$  is the web thickness,  $t_E$  is the embedding depth,  $f_{ck}$  is the characteristic compression strength of concrete,  $a_s$  is the area of transverse rebars,  $\mu$  is the friction coefficient between steel and concrete and  $\gamma_v$  is the partial safety factor.

Another proposal was developed by Reichle and Kuhlmann [9] for embedded type connections with horizontal headed studs according to Eq. (2).

$$P_{Rd,L,RK} = \frac{11500}{L_w \cdot \gamma_v} k_b k_s k_\alpha k_{a1} f_{ck}^{0.6} \mu^{0.3} t_E^{0.35} t_w^{0.2} a_{sw}^{0.05} (1 + a_{sa})^{0.05} \quad (2)$$

where  $k_i$  are coefficients depending on the layout of headed studs and corrugation profile,  $a_{sw}$  is the area of the stirrups beside the web and  $a_{sa}$  is the area of additional transverse rebars placed above the web.

The above formulas are applied to evaluate the resistance of the experimentally studied connections and compared to the experimental results, as detailed in Section 4.

### 3. Experimental program

#### 3.1. Test specimens

The experimental research is performed at the Budapest University of Technology and Economics, Department of Structural Engineering in 2017. In the frame of the program 5 large scale push-out tests are performed having the same trapezoidal profile. The layout of the specimens are similar as that used in [6] and [9].

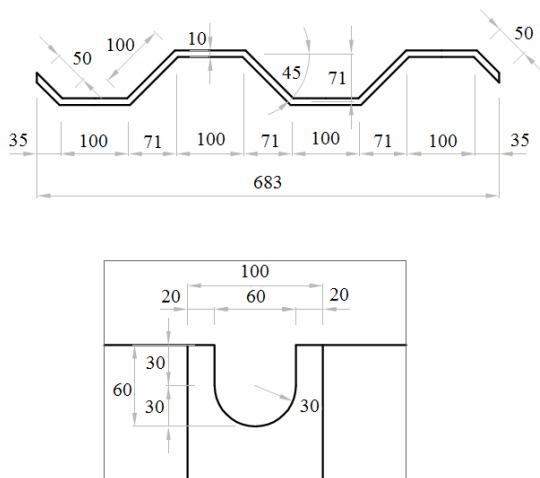

Fig. 3. Web profile and cut-out geometry [mm].

The geometrical and material properties of the specimens and the notations are given in Figs. 3-4 and in Table 1. The interface between steel and concrete is greased to avoid adhesion bet between the steel and concrete surfaces in the production phase and five concrete cubes are prepared for each mix for material tests. The material properties of the steel web are determined by tensile coupon tests.

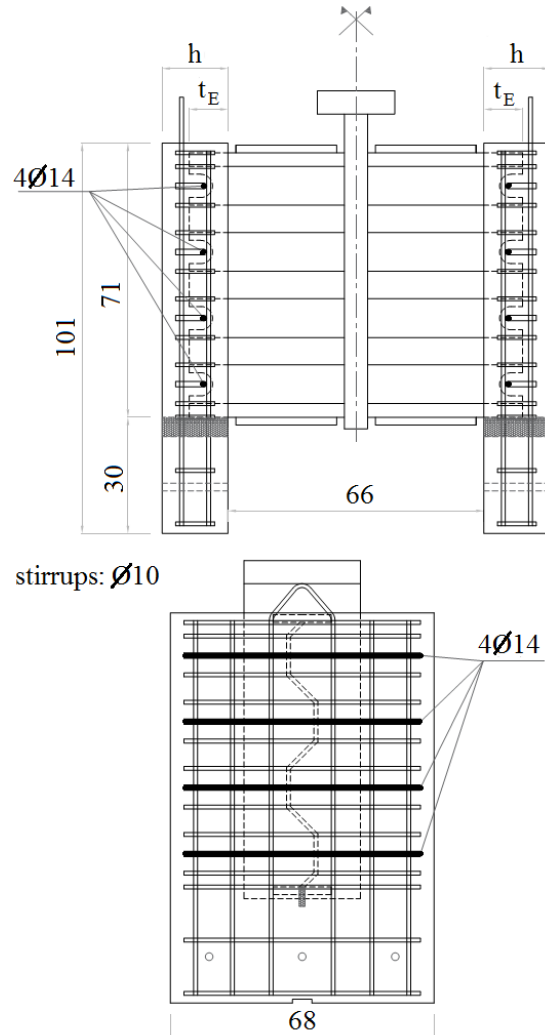

Fig. 4. Test specimens' geometry [cm].

The casting of specimens' slabs were performed in two casting time, performed in horizontal positions with two days difference. After the casting and hardening of the first slab the formwork was dismantled and the specimen was turned over in order to cast the second concrete slab. In the specimens stirrups with 10 mm diameter are applied. The concrete slab depths ( $h$ ) are 170 or 200 mm with 100 or 150 mm embedding depth of the web ( $t_E$ ), respectively. In the case of specimens P17-T, P22-T, P17-T-14 and P22-T-14 trapezoidal webs

are used and embedded into the concrete slabs shown in Fig. 4. In the case of specimen P22-I a HEM300 girder is applied instead of trapezoidal web and corrugated plates are welded onto the outer side of the steel flanges as shear connectors. In the cases of specimens P17-T-14 and P22-T-14 transverse rebars ( $\phi_s = 14$  mm in diameter) through steel cut-outs are applied as shown in Fig. 3. In the other specimens (P17-T, P22-T and P22-I) the corrugated web is simply embedded into the concrete slab without any further connectors or cut-outs for concrete dowels. These specimens are used as references. The measured compression strengths of concrete slabs are obtained between 40 and 50 MPa and the yield strengths of steel is obtained to 367 MPa, respectively, tabulated in Table 1.

Table 1. Geometric and material parameters in [mm] and [MPa].

Specimen	h	t <sub>E</sub>	$\phi_s$	f <sub>c,test</sub>	f <sub>y,test</sub>
P17-T	170	100	-	50	367
P22-T	220	150	-	49	367
P22-I	220	150	-	40	367
P17-T-14	170	100	14	40	367
P22-T-14	220	150	14	40	367

### 3.2. Test setup

The test arrangement and setup is presented in Fig. 5. To capture the slip between the corrugated web and concrete slabs linear variable displacement transducers (LVDT) are placed to the slab-to-web connections. The deflection of the vertical steel plate is also measured with LVDT. The load is produced by a hydraulic jack with a maximum loading capability of 6000 kN. The concentrated force is introduced through a rigid steel load transfer element. In addition three steel rods are applied at the bottom side of the specimens to carry the horizontal forces coming from the eccentricity of the vertical force.

### 3.3. Testing procedure

Each specimens are loaded by static load till the final collapse of the specimens. During the loading process up- and unloading cycles are executed at least 25 times around 40% of the predicted ultimate load of the specimens in order to determine the elastic response, the stiffness in the elastic domain and to make sure that any

bond between the steel web and the concrete slab is terminated. The load-displacement curves of all the test specimens are measured with the cracking and ultimate collapse mode.



Fig. 5. Test arrangement.

## 4. Test results

During the laboratory tests, the applied load and the slip at the web-to-slab connections are measured. The measured and calculated ultimate capacities of the specimens are tabulated in Table 2. The ultimate resistances of the shear connections are also evaluated based on the previous proposals of Novák and Röhm [6] and Reichle and Kuhlmann [9] introduced by Eqs. (1) and (2), respectively. However, it is to be noted that the parameter domain of the proposed formulas is not valid for the current analyzed connection geometries. The comparison shows that the proposed resistance models are conservative and provide safe side solutions. The differences are obtained between 20% to 52%. The measured ultimate capacities show that by using transverse rebars through cut-outs in the web the resistance to longitudinal shear increases 60% and 78% in the case of specimens having trapezoidal web with 100 mm and 150 mm bedding depths, respectively.

It can be observed from the results presented in Table 2 that the embedding depth of the trapezoidal web in the concrete has a significant effect on the connection resistance. Without the use of transverse rebars the capacity is improved by 25% if bedding depth of 150 mm is applied instead of 100 mm. If transverse rebars are also

applied the effect of the embedding depth is more significant by causing 37% increment in the ultimate resistance.

Table 2. Ultimate capacities of specimens.

Specimen	$P_{test}$ [kN]	$P_{Rk,L,NR}$ [kN]	$P_{Rk,L,RK}$ [kN]	$P_{test}/P_{Rk,L}$
P17-T	1031	-	862	1.20
P22-T	1297	-	994	1.31
P22-I	1859	-	-	-
P17-T-14	1677	1267	-	1.32
P22-T-14	2307	1517	-	1.52

The force – relative displacement curves of each specimens are shown in Fig. 6. It can be observed that each specimen had practically the same initial stiffness. It is shown that specimens with embedded trapezoidally corrugated web show less resistance degradation after exceeding the resistance than that of with steel flange (red curve representing specimen P22-I), however, by comparing the specimens P22-T and P22-I the shear capacity is 43% greater if steel flange is used. The slip between the web and concrete slabs reached 30-45 mm in the tests before unloading.

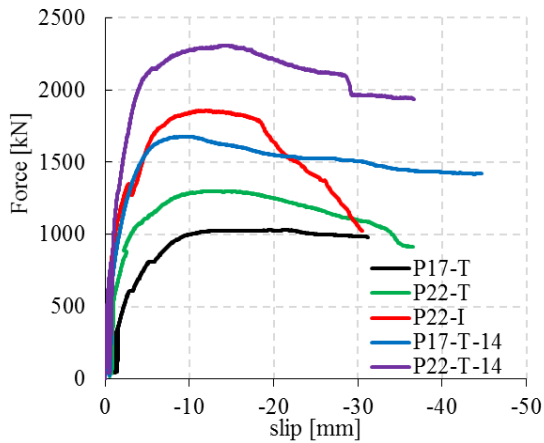

Fig. 6. Force-displacement curves.

The typical collapse modes of the specimens are presented in Figs. 7-9. In the case of specimens P17-T and P22-T due to the lack of transverse rebars the failures occurred by transverse bending of the concrete slab. It is caused by the horizontal force of the inclined web panel being responsible for the opening of the slab in the transverse direction during longitudinal shear. This failure is shown in Fig. 7. In the case of specimen P22-I the same failure

mode is observed due to the lack of transverse rebars shown in Fig. 8.



Fig. 7. Transverse bending failure (P22-T).



Fig. 8. Transverse bending failure (P22-I).



Fig. 9. Concrete crumbling at the web-to-slab connection (P17-T-14).

In the case of specimens P17-T-14 and P22-T-14 where transverse rebars are applied the failures are caused by the concrete slab crumbling at the web-to-slab connection between the inclined web folds shown in Fig. 9. The opening of the concrete slab in the transverse direction can not occur due to the transverse rebars working against transverse bending caused by the inclined web folds. The final collapse of these specimens is caused by the fracture of the transverse rebars.

## 5. Conclusions

In the paper the structural behavior of the embedded connections of steel trapezoidal corrugated web hybrid girders are studied by push-out tests. The aim is to investigate the longitudinal shear capacities of embedded type connections. In the frame of the research program 5 push-out specimens are tested investigating the effect of the embedding depth of the web in the concrete slab, the existence of the concrete dowels (through cut-outs in the steel web) with transverse rebars and the influence of the application of the steel flange. Based on the results the following conclusions are drawn:

- (i) the embedding depth has significant increasing effect on the longitudinal shear resistance;
- (ii) the use of transverse rebars influences the failure mode and shear capacity as well;
- (iii) with the lack of transverse rebars the failure is caused by transverse bending of the concrete slab due to the opening effect of the inclined folds of the web resulting smaller shear capacity;
- (iv) the application of transverse rebars improves the connection's resistance and the failure is caused by the concrete crumbling between the inclined folds of the web;
- (v) the application of steel flange has an increasing effect on the shear capacity, however, the resistance shows significant degradation by increasing the deformation.

## Acknowledgement

The presented research program is part of the "BridgeBeam" R&D project No. GINOP-2.1.1-

15-2015-00659; the financial support is gratefully acknowledged. Through the first, second and fourth authors the paper was also supported by the *ÚNKP-17-3-IV.*, *ÚNKP-17-2-I.* and *ÚNKP-17-4 New National Excellence Program of the Ministry of Human Capacities*, respectively; the financial supports are gratefully acknowledged.

## References

- [1] EN1994-1-1:2004, Eurocode 4: Design of composite steel and concrete structures, Part 1-1: General rules and rules for buildings.
- [2] Nakasu K, Yoda T, Sato K. Study on out-of-plane bending of concrete dowels in a composite girder with corrugated steel web. *Proc. JSCE* 2000;647(I-51): 267–279.
- [3] Kosa K, Awane S, Uchino H, Fujibayashi K. Ultimate behavior of prestressed concrete bridge with corrugated steel webs using embedded connection. *Proc. JSCE* 2006;62(1):202–220.
- [4] Shiji A, Ooyama H, Yoda T. Experimental study on the new joint structures of a bridge with corrugated steel webs. *Journal of Structural Engineering JSCE* 2008;54A:759–768.
- [5] Taira Y, Aoki K, Hagiwara N, Ito A, Hirose T. Connection joint between lower slab and corrugated steel webs applied to PC-box girder. *Journal of Structural Engineering JSCE* 2009;55A:1066–1074.
- [6] Novák B, Röhm J. Anwendung von Trapezblechstegen im Brückenbau – Längsschubtragverhalten von Betondübeln in Kombination mit Trapezblechstegen. *Beton- und Stahlbetonbau* 2009;104(9):562–569.
- [7] Röhm J, Novák B. Querbiegetragverhalten von Betondübeln bei Verbundtragwerken mit Trapezblechstegen. *Beton- und Stahlbetonbau* 2010;105(3):176–185.
- [8] Kim SH, Ahn JH, Choi KT, Jung CY. Experimental evaluation of the shear resistance of corrugated perfobond rib shear connections. *Advances in Structural Engineering* 2011;14(2):249–263.
- [9] Raichle J, Kuhlmann U. Trapezblechstege im Verbundbau – Längsschub und Querbiegung der Verbundfuge mit randnahen Kopfbolzen. *Stahlbau* 2015;84(10):763–770.
- [10] Wang S, He J, Liu Y, Li C, Xin H. Shear capacity of a novel joint between corrugated steel web and concrete lower slab. *Construction and Building Materials* 2018;163: 360–375.