

Document downloaded from:

<http://hdl.handle.net/10251/121084>

This paper must be cited as:

Otey, J.; Company, P.; Contero, M.; Camba, J. (2018). Revisiting the design intent concept in the context of mechanical CAD education. *Computer-Aided Design and Applications*. 15(1):47-60. <https://doi.org/10.1080/16864360.2017.1353733>



The final publication is available at

<https://doi.org/10.1080/16864360.2017.1353733>

Copyright CAD Solutions

Additional Information



Revisiting the Design Intent Concept in the Context of Mechanical CAD Education

Jeffrey Otey[0000-0002-3763-8759]¹, Pedro Company[0000-0001-6399-4717]², Manuel Contero[0000-0002-6081-9988]³ and Jorge D. Camba[0000-0001-5384-3253]⁴

¹Texas A&M University, j-otey@tamu.edu

²Universitat Jaume I, pcompany@uji.es

³Universitat Politècnica de Valencia, mcontero@upv.es

⁴University of Houston, jdorribo@uh.edu

ABSTRACT

In the area of history-based parametric mechanical Computer Aided Design (CAD), design intent is generally understood simply as a CAD model's anticipated behavior when altered. Besides, it is commonly accepted that design intent information is automatically and implicitly embedded in the model's design tree (the standard graphical representation of the sequence of features that form the structure of the parametric model) as the model is created. However, this representation provides an extremely simplified view of the model's construction and purpose, which may hinder its general understanding and future reusability. Our vision is that design intent communication may be improved by recognizing the multifaceted nature of design intent, and by instructing users to convey each facet of design intent through the better-fitted CAD resource.

This paper reviews the current understanding of design intent and its relationship to (and evolution from) design rationale in the context of mechanical CAD models. The paper also builds on the idea that communication of design intent conveyed through CAD models can be satisfied at three levels (sketch constraints, relationships between modeling operations, and the modeling operations themselves), provided that specialized instruction (by way of rubrics) is used to instruct users in selection of the most suitable level for each intent.

Keywords: design rationale, design intent, CAD model quality, CAD education.

1 INTRODUCTION

Feature-based parametric CAD is a commonly deployed 3D modeling technology that is widely used in industrial settings. In these systems, the 3D CAD model is created by gradually and sequentially adding geometric features through parent/child relationships, which creates an interconnected

structure that, when defined properly, allows for more flexible and reusable models. This process is recorded in a structure known as a design tree, feature tree, or history tree.

Parent/child interdependencies are the basic elements that facilitate CAD reusability and alteration of parametric models. When these dependencies are defined properly, changes in the artifact can be performed efficiently, as alterations propagate automatically from parent to child nodes. However, parent/child dependencies can also be the root of numerous regeneration problems, which often forces designers to rebuild the CAD model entirely, costing time and money.

Previous researchers have determined that 48% of CAD models fail during design exploration [38] and according to the 2013 State of 3D Collaboration and Interoperability Report, 49% of engineers spend more than 4 hours per week repairing design data with 14% spending more than 24 hours per week [39]. The same report states that 32% of organizations miss deadlines due to design data problems [39]. Gerbino states that data exchange issues result from poor modeling strategies [28]. González-Lluch and colleagues echo these sentiments stating that erroneous CAD models that filter toward downstream applications require effort to rework the models to remove data corruption [29]. Poor understanding and/or communication of design rationale and design intent are commonly argued to cause most of those failures. But the concepts of design rationale and design intent are complex in themselves.

Describing the purpose of a design and the justifications for specific decisions made when creating it are essential tasks for engineers and design professionals. Design rationale can be defined as the explicit documentation of the reasons behind the decisions made when designing a system or artifact [52]. Although design rationale applies to a number of disciplines [63], its representation and management significantly vary across diverse fields. For example, communication of design rationale through source code comments has been a relevant research topic in software engineering for a number of years [40]. In product design however, special tools and approaches are required, as the artifacts used to represent design in CAD systems are much more complex than simple text comments. Despite the ongoing research, fixing a generally agreed definition of the term and finding efficient mechanisms to convey design rationale in product and engineering design are still open issues that cause a noticeable lack of general tools to support design rationale communication.

This paper compares existing definitions of design rationale, determining that design intent communication is a crucial initial step towards understanding design rationale. Further, the paper considers the definition of design intent, concluding that to the best of the authors' knowledge, a standardized manner in which to explicitly communicate or deduce a CAD model's design intent does not yet exist. Wang and colleagues, who studied a push system to provide shared design knowledge, support this view, recognizing that "no existing knowledge acquisition method is satisfied to support mechanical conceptual design [73]."

The review of the current understanding of design intent and its historical connection to design rationale is presented, focusing on the difficulties encountered when conveying design intent through CAD model geometry, resulting in most parametric modeling applications offering various complex sets of tools to manage this information. In this context, it is recognized that current research [20] focusing on defining quality metrics used to verify that design intent is properly incorporated into the modeling strategy is successfully implemented when constructing the CAD model. Thus, it is finally suggested that the capture and transfer of each type of design intent is manifested at its most appropriate representation level: sketch constraints, modeling operations, and relationships between modeling operations. Finally, the current state of design intent instruction is addressed, with recommendations for future advances.

2 DESIGN RATIONALE

Before the idea of design rationale became commonplace, industrial products and their components were described exclusively in terms of how they functioned, but not why they were designed in a certain way [63]. As a result, the time and communication effort required of collaborative teams to reason and understand each other's designs increased significantly as projects grew in complexity. Design rationale systems were introduced as basis of reasoning and communication among such teams [15].

The term design rationale has historically been defined in a variety of ways. For example, Shum and Hammond defined it as "elements of the reasoning which has been invested behind the design of

an artifact [67].” Sim and Duffy describe it as “the reasoning and argument that leads to the final decision of how the design intent is achieved [69].” The same authors also define design intent as the “expected behavior that the designer intended the design object should achieve to fulfill the required function [69].” A more complete definition was suggested by Lee: “Design rationales include not only the reasons behind a design decision but also the justification for it, the other alternatives considered, the tradeoffs evaluated, and the argumentation that led to the decision [48].”

Szykman and colleagues define design rationale as the documentation of the design intent of an artifact [71]. They also contend that schemes are needed to retrieve, clarify, and facilitate exploitation of design information. These systems should capture and represent the progression of design intent, comprehension about the model throughout the development process, and associations, which link decisions. ISO defines design rationale as the, “logic underlying the methodology and used in constructing the design [34].”

Design rationale consists of different types of information such as the history of the design process and the reasons for making each decision. This knowledge can be useful at various stages such as design verification, evaluation, reuse, teaching, communication, documentation, and maintenance [11].

The state of the art for defining design rationale is summarized in the IBIS-like schema (Issue-Based Information Systems), created by the authors shown in Figure 1. An IBIS schema is an approach to represent complex problems that involve multiple stakeholders. It was invented by Kunz and Rittel [45] and is the base on top of which new schemas are being developed (such as ISAA—Integrated Issue, Solution, Artifact, and Argument—by Zhang et al. [77]).

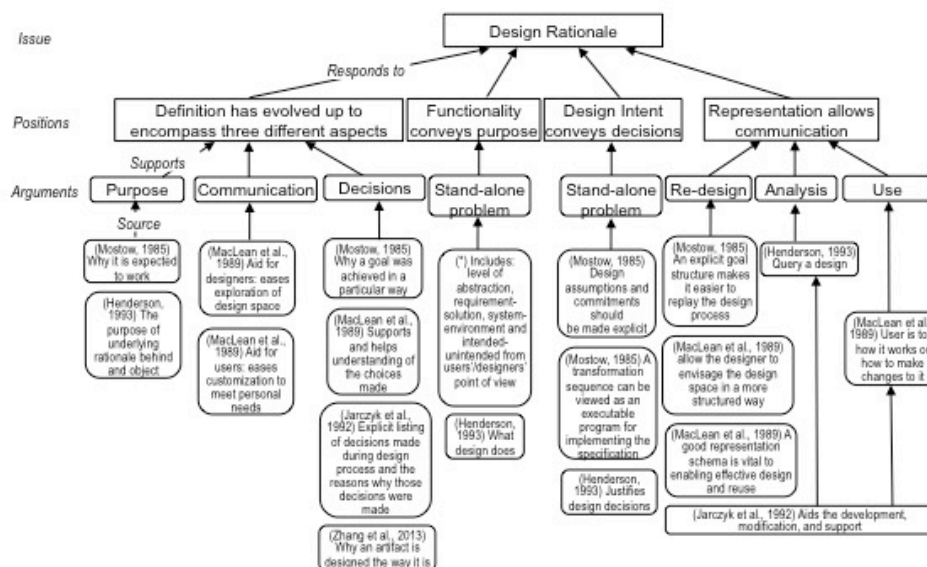

Figure 1. Schema illustrating current dispersion in understanding of design rationale.

As shown in the schema, Mostow [54] first realized the importance of making design rationale explicit, but his work was directed toward finding better models of the design process. In investigating the global design progression, he stated that design rationale is just one step in the design process. According to him, design rationale clarifies and justifies why a certain decision was made and why it was thought to be the correct path to take. Design rationales need to be both explicit (clearly defined goals) and appropriate (reasons given why a certain path was chosen) [54].

MacLean et al. [52] focused on defining and representing design rationale, highlighting its role as an aid for both designers and end users. The researchers emphasize its importance, describe its benefits, and develop a “semi-formal” notation to make it explicit [51]. Unfortunately, their

representation is aimed at computer software design and does not consider product design peculiarities. Lee and Lai [49], also focusing on software design, highlighted the importance of selecting a suitable representation, and provided a framework for evaluating a design rationale representation. This framework increasingly discerns explicit elements of design rationale and supports multiple design tasks. They discuss and evaluate Decision Representation Language (DRL) in order to accomplish these tasks.

In attempting to integrate physical and conceptual models, Henderson divided product models into physical and meta-physical domains [33]. The physical domain integrates all information related with a model's actual manifestation, such as geometry, dimensions, and materials while the meta-physical realm refers to information that describes the structure and behavior of the model. It is argued that metaphysical modeling provides the capability to capture the function and design intent of systems, assemblies, parts, features, and even individual dimensions and tolerances. This modeling process uses Product Definition Units (PDU), which are shells used to encapsulate information. Henderson indirectly defines design rationale, as he describes design intent as "the purpose or underlying rationale behind an object [33]." While this definition does not represent the current understanding of design intent, the term attempts to explain the difference between intent and functionality ("intent justifies a design decision whereas the functionality just tells what the design does").

Karsenty evaluated the importance of representing design rationale in cases where the original design is reused [42]. His research questioned six designers about their need to understand previous design rationale, how archived design rationale was utilized, and how to effectively acquire design rationale. He states that design rationale could be beneficial for those requiring reinforcement for design-based decisions, but it is not adequate to be used as the sole support. In fact, he used the QOC Notation originally developed by MacLean et al. [52] to document design rationale.

In addition to the review of early contributions, open problems, and a classification of systems and tools for design rationale capture and retrieval in the context of CAD tools, the work by Regli et al. [63] is also compelling as it clearly identifies the multidisciplinary nature of design rationale. According to the authors, a problem develops when design collaboration is needed and communication is absent; and design rationale is crucial to avoid these problems. Their work states that the need for design rationale is a collective problem, encountered in all industries, but design rationale systems are uncommon. Design rationale systems need to assess design approaches, representation schema, capture, and retrieval. A system, which could capture such information, would be important for those tasked with managing design data.

A recent study examined the understood purpose of a design between industrial designers and design engineers in order to increase collaboration [46]. They found that complex and abstract industrial design elements (ex. meaning, emotions, etc.) were less shared with engineers and that various aspects of the design are perceived separately, ensuring that the shared knowledge is less meaningful to the engineers [46].

Additionally, the extent to which we can benefit from design rationale depends largely on the language used to represent it [49]. The work by Karsenty [42] is a significant contribution in regards to measuring the goodness of captured design rationale. The work by Bracewell and colleagues [8] is also noteworthy, as it describes a strategy to implement customized tools to capture, represent, and retrieve design rationale.

A more recent contribution in the area of design rationale is due to Zhang and researchers [77], which not only highlights the relationship between design intent and design rationale, but also investigates why only a small amount of design rationale systems have been implemented in industry. It appears that the limitations exhibited by the traditional approaches to capture design rationale summarized by Karsenty [42] and recently addressed by Bracewell et al. [8] are still valid.

As shown in Figure 1, design intent is a significant contributor to design rationale, but it can be studied as a stand-alone problem, which will be considered in the next section. Design rationale describes the purpose of a design, the reasons relating why certain steps were taken in artifact creation, and also aids communication in a collaborative environment, particularly for end users. Functionality conveys purpose, and the literature on function reveals that this is a separate ambit where there exist many views of function, and not all of these views are made explicit [70]. The authors conclude that accepting the multifaceted nature of design rationale is a mandatory aspect to confront the unsolved problem of finding a suitable language to represent it.

3 DESIGN INTENT

Design intent is a nebulous concept. Some authors have even stated that a formal definition of the term is problematic to obtain [17], although many have attempted to describe it. Others use the term without providing any definition [3]. ISO defines design intent as the, “intentions of the designer of a model with regard to how it may be instantiated or modified [35].” In a pioneering work by Requicha and Rossignac, they do not explicitly define design intent, but emphasize that product models contain unambiguous information about behavior and function and most relevant data is associated with design features [64]. In reality, it is a common assumption that a standard definition is understood already, as many authors use the term “design intent” without providing an explicit definition while other researchers use implicit references to it. Wiebe states that the use of CAD models implies that information traditionally documented in working drawings is now housed in the model database [74].

In a survey conducted by Iyer and Mills [37], common elements were identified in a number of definitions and interpretations of design intent. This information was used by them to provide a comprehensive definition in the domain of 2D CAD: “Design intent contained in legacy CAD is the insight into the design variables (design objectives, constraints, alternatives, evolution, guidelines, manufacturing instructions and standards) implicit in the structural, semantic and practical relationships between the geometric, material, dimensional and textual entities present in the CAD representation.” [37]. They also acknowledged the capture, representation, and retrieval of design intent as open issues for future research.

Although a lack of consensus exists within the scientific and technical community on the exact definition of design intent, there is agreement on its importance and the benefits of an explicit representation. Advantages were summarized by Pena-Mora et al. [57] in the form of four points:

- Changes in complex projects require certain design decisions to be modified during the development process. When the justifications defined during the initial stages are lost, they need to be recreated, which has a negative impact on project costs and development times. The ability to store, process, and retrieve this information can significantly improve productivity.
- When design intent information is represented explicitly and is easily available for review, the overall quality of the product increases.
- Explicit representation of design intent leads to a more intelligent use of resources and knowledge.
- Efficient communication of design intent is essential for integrating solutions and transferring design knowledge.

An IBIS-like schema summarizing the state of the art for defining design intent is illustrated in Figure 2.

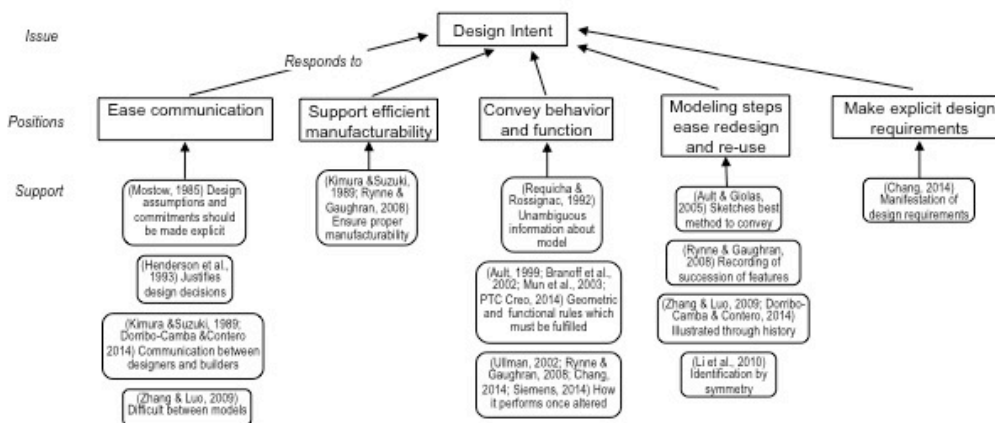

Figure 2. Schema illustrating current dispersion in understanding of design intent.

The schema reveals the multifaceted nature of design intent, as it mainly conveys behavior and function, but it also makes design requirements explicit and eases communication. In doing so, design intent facilitates redesign and reuse, and even efficiently supports manufacturability.

Mun et al. define design intent as the cluster of geometric and functional rules that must be fulfilled by the final product, represented by parameters, constraints, features, and history [55]. Kimura and Suzuki define design intent as the way original designers articulate the objectives of the design so that the manufacturer can understand the design process in order to ensure proper manufacturability without hampering design performance [43]. Design intent defined in this manner incorporates design requirements, behavior, and function while facilitating communication between designers and builders. They further state that design intent plays a vital role in communication in simultaneous design.

In their research on modeling strategies in CAD pedagogy, Rynne and Gaughran define design intent as a description of how an object is modeled and also how it should perform once it is altered [65]. They also assert that CAD software records the succession of features used to create a model, which reflects the user's opinion of the best approach to accomplish a specific task. They further state that design intent should be more comprehensive than shapes and sizes of features, but must encompass consideration of manufacturing methods and relationships between features. A student's ability to accurately model an object correlates with their ability to visualize and assemble the objects cogently.

Ullman alludes to a consensus among the CAD community whereas intent exemplifies the arranging of geometric constraints in a parametric system. This classification defines the geometric dependency needed by the system in order to enable alterations [72].

Ault and Giolas interviewed experienced CAD designers to shed light on current industry practices [5]. Several interviewees believed that sketches provide the best method to convey design intent, however there is a tradeoff between complicated sketches and history tree clarity in order to reveal relationships between features.

Zhang and Luo state that CAD illustrates design intent through its history, features, parameters, and constraints [76]. They state that design intent not only describes an artifact's requirements and constraints, but can also serve an expectant role in the design process. Their research examined methods used to share design intent information between models, but encountered difficulties resulting from an absence of standards and data-exchange procedures.

CAD software manufacturers specify the concept of design intent differently. Siemens' NX [68], for example, infers that design intent can be extracted by associative parameters, expressions, and constraints so that predictable modification can be achieved. In "history-free mode," design intent guidelines are contingent upon prevailing geometric interactions [68]. SolidWorks [23] defines design intent as "...how your model behaves when dimensions are modified." PTC Creo [60] provides a definition of design intent where the knowledge of the artifact can be obtained by means of parametric and spatial relationships that define the purpose and fit of the part. The authors believe that these definitions do not represent the conventional understanding of this term. Furthermore, oftentimes problems with the software itself generate a lack of design intent communication, as detailed by Bodein et al, where reusability may be hampered when the relationship between constraints and history is not explicit [7].

Despite the differences among the various definitions of design intent, it is generally agreed that it is difficult to convey design intent through CAD models. As a result, scholars rely on different methods to communicate this information to others. Some believe that the parametric modeling software can record these data [ex. 65], but while the software can indeed reflect the specific steps taken to create the artifact, it cannot relate why certain commands were used (e.g. why was it considered to be superior to "extrude" a profile rather than to "revolve" a profile?).

Ault declares that design intent can be acquired by equations used to impose geometrical restrictions based on functional requirements of products [4]. Branoff et al. state that dimensioning and geometric relations are devices for establishing design intent within the CAD model [9]. Bodein and colleagues claim that it is unacceptable that CAD software should provide no capability for the designer to include comments, which are needed to reduce design time [7]. Camba et al. echoed these thoughts by stating that design intent is often embedded in the modeling approach and in the dependencies between features in the CAD software [26],[14]. Their research details methods to use

annotations for enabling increased design communication. These annotations are then housed within the CAD model and can be integrated in a Product Lifecycle Management (PLM) system.

The complementary approach to explicitly conveying design intent is trying to automatically detect implicit design intent. Li et al. researched methods to detect design intent primarily by using symmetry [50]. They emphasized the identification of design intent by locating prospective geometric abnormalities. Li and colleagues state that geometric constraints and associations between edges, faces, and dependent geometries in CAD models can properly articulate design intent. Their work focused on models bounded by planes, spheres, and cylindrical surfaces, but did not include common curved geometries. Plumed and colleagues researched methods to determine design intent embedded in 2D sketches [58]. A drawing can be dissected into features, and analysis of such combinations of features can illuminate design intent. The most common features can then be catalogued and identified. Continuing research attempts to examine the feasibility of creating algorithms, which mimic designers' experience and knowledge to extract design intent from sketches.

Even when commonalities exist between various definitions of design intent, oftentimes the manner in which it is assessed (if it is even assessed at all) is inaccurate. To name but one example, design intent that is judged purely by quantity metrics (such as the amount of features or sketches in the design tree) is inherently inaccurate. While quantity metrics are intuitive and easy to calculate, their results may be a poor measure of the model efficiency, as their contribution is nonlinear. When the count is low, the addition of one more is significant, but as the count increases the overall significance of each new item decreases [56].

3.1 Representation Levels of Design Intent

As illustrated in Figure 1, one of the primary ideas in Design Rationale is that representation allows communication. This concept should be taken into consideration in order to maximize the resources provided by CAD systems to explicitly communicate the intention of the CAD user during modeling tasks. For instance, proper labeling of modeling operations is clearly a simple way to convey design intent (Figure 3), as it eases redesign, analysis, and reuse of CAD models.



Figure 3. Proper labeling of modeling operations as a simple way to convey design intent. Default naming (right tree) vs. proper naming (left tree).

By examining the common structure of commercial MCAD systems, it appears that the design tree is the key representation tool used to manage design intent communication. The authors observe that design intent may be embedded at three different levels:

1. Sketch constraints.
2. Relationships between modeling operations.
3. Modeling operations.

In certain situations, all three alternatives are available to express design intent. For example, in Figure 4, a simple cylindrical casing is modeled using three different approaches, each of which embeds design intent information at a different level. To guarantee that the cylindrical shape of a casing and its internal hole are concentric, the first approach would link two circles through a concentric constraint defined at sketch level before producing the casing by an extrusion operation.

The second approach would result from first extruding the cylindrical shape, then producing the coaxial hole through the cylinder. The two approaches work at different levels (sketch level for the first approach and modeling operations for the second). But in both cases, the approaches assume that cylindrical shapes are to be obtained from extruding circles. This ambit reveals a line of thought where the mind's eye first works in 2D (circle) and then extends the result up to 3D (cylinder). However, a cylindrical shape may also be obtained through a revolution operation applied to a generatrix. In our example, the casing shape may be obtained by revolving a slender rectangle around an external axis of revolution. This option (which changes the strategy at the third level) is less intuitive, as we only see a rectangle, but it explicitly defines the axis that is (a) single and (b) shared by both generatrices. As a result, the cylindrical shape and the cylindrical hole are necessarily coaxial.

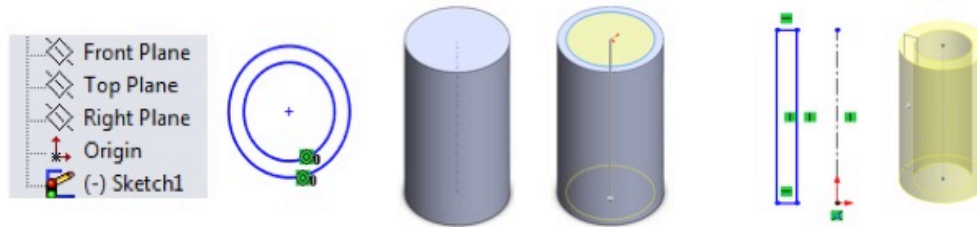

Figure 4. Three approaches to model a casing, referred to from left to right: (a) Sketch Constraints (ex: concentric link between circles at revolve sketch level plus extrusion.), (b) Relationships between Modeling (ex: construction of cylinder followed by construction of coaxial hole.), and (c) Modeling Operations Itself (ex: Profile of casing wall and profile to create casing (revolve)).

Selecting the best of the three levels to introduce design intent in CAD models requires agreement between contradictory criteria; because the three levels described above have different visibility. They also differ in easiness to be defined and modified. For example, adding constraints to a sketch is fast and reliable, but hides the design intent within the sketch, which is not directly visible when inspecting the design tree. This issue should be considered when it is possible to choose between multiple representation levels. Choosing those alternatives that are directly visible on the design tree facilitates future analysis and understanding of the CAD model, but may also be inefficient in certain situations.

One example of hidden references is shown in Figure 5, where the reference axis (surrounded by a lasso) is embedded in the base profile, where unnoticed changes in the profile may inadvertently change the scaffold.

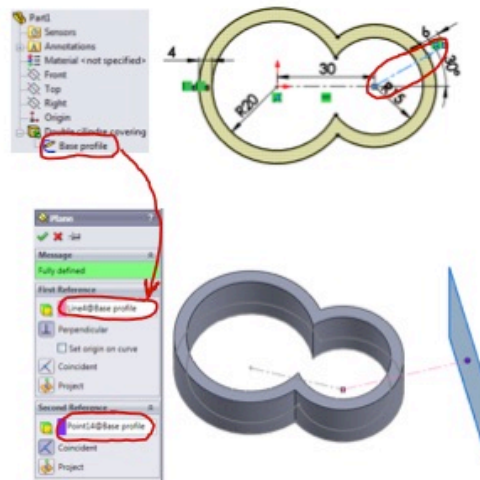

Figure 5. Example of reference datum supported by one line embedded in a profile.

Enhancing the visibility of design intent requires expert users capable of working with sophisticated modeling operations, which greatly affects model portability. For example, adding constraints at the 3D level is somewhat more limited than the 2D alternative, since available constraints are usually reduced to bilateral symmetry and rectangular and polar replication patterns. On the other hand, these 3D transformations help improve the visibility of design intent.

The 3D approach is also more sensitive to round-off errors. For instance, adding a symmetric element to a body by a bilateral symmetry operation (as the second lug in Figure 6) may unintentionally result in a multi-body model, simply because round-offs in the size or the location of the symmetric element (more likely to occur in 3D calculations than in 2D) may produce small cracks that prevent the new element from being merged to the main body.

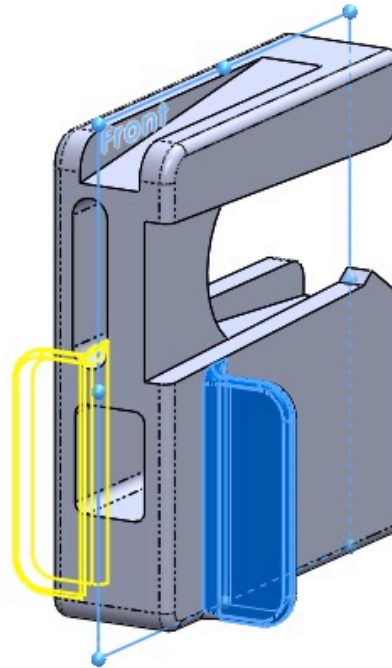

Figure 6. Addition of a second lug using symmetry.

The embodiment of design intent is associated with, “readability, alterability, and usability of CAD models [53].” Mandorli and colleagues state that engineers are able to deduce design intent by the artifact’s shape, dimensions, and tolerances and are interested in translating design intent representation from historical 2D drawings into 3D objects [53].

Explicit, or at least easily accessible, design intent communication is a first step toward expressing design rationale in a proper manner and supporting the creation of CAD models that are ready for redesign, analysis, and reuse. It is essential for CAD users to realize their modeling decisions must express, as clearly as possible, what the expected behavior of the model should be. The most appropriate representation level of design intent (sketch constraints, relationships between modeling operations, and the modeling operations themselves) must be selected; so all information is communicated effectively. Furthermore, the authors consider that explicit communication of design intent must be a core ingredient of CAD instruction.

3.2 Capture and Transfer of Design Intent

There has been much research and discussion, from the early development of parametric modeling, about how best to capture design intent. In general, researchers realize that the extraction and sharing of design intent is crucial [75],[66], but previous attempts have failed because of incompatibilities in software and inefficient storage methods [1].

An early examination by Will [75] focused on industry use of simulation and modeling and concluded that access to past designs and their design intent was crucial to industrial product development. He also believes that this information needs to be recorded and placed in libraries so that engineering changes can be made using this data. Shih and Anderson, while investigating product model data sharing, state that if this data cannot be captured and retained, a barrier exists preventing the exchange of product information between designs [66]. In a continuing study, Anderson and Ansaldi state that data exchange between CAD software is problematic, because they use different constraints and algorithms in the solvers [1]. In addition, CAD vendors would resist standardization of the solvers in order to protect their proprietary systems [1].

To alleviate data exchange problems, various software solutions have been suggested. Anthony et al. describe an approach to use Conceptual Understanding and Prototyping environment (CUP) to capture design intent [2]. CUP documents design information about assemblies and stores it using concepts characterized by XML [2]. Similarly, Choi et al. suggest using macro files [19]. In their study, commands are grouped into categories and ACIS 4.0 (a geometric modeling kernel) is used to generate an internal geometric model in order to overcome unresolved command mapping between software [19]. Fu et al. state that development of software-independent tools is necessary to manage CAD data and the conversion of design intent into process-applicable information [27].

Further research points toward CAD data exchange standards in order to facilitate design intent transfer. However, the main issue related to this approach is that the more widely used neutral formats such as IGES or application protocols 203 and 214 of ISO 10303 (STEP) do not support the transfer of sketch constraints or modeling operations (features) and their relationships, as recognized by Pratt et al. [59]. In addition, design intent information is lost during file transfer between systems because STEP does not allow representation of it [59]. This situation has started to change since the 2014 publication of the first edition of Application Protocol 242 (AP242), “Managed model based 3D engineering.” Valid implementations of this protocol are beginning to appear, which are expected to alter the situation drastically. This new application protocol supports all the elements mentioned previously, however, there is no current commercial CAD application that supports the units of functionality related to parametric history-based feature-based modeling. According to Chang, a plan for incorporating design intent, features, and profiles with corresponding constraints and dimensions is highly beneficial, especially for new CAD users [16]. Pressure from end-users and industry should finally force CAD developers to implement the whole AP242 capabilities fully.

Another important aspect related to the transfer of design intent is that oftentimes the lack of tools for the visualization and analysis of relationships between features in CAD models presents an important barrier for understanding design intent. As detailed by Bodein et al, reusability of CAD models is hampered in that the relationship between constraints and history is not explicit [7]. They also declare that the history tree does not adequately express the relationship between features, especially if certain features are created in a nonlinear process [7].

3.3 Design Intent Instruction

Effective learning of MCAD tools remains a major challenge in both academic and industrial settings, with most educational practices focusing on declarative and specific procedural command knowledge, as classified by Chester [18]. Declarative command knowledge is related to generic commands or algorithms that are typically available within MCAD systems, such as geometric transformations (i.e. patterns and mirroring operations), or basic solid modeling operations (i.e. extrusions or revolutions). The practical application of this realization to a particular CAD system requires specific procedural command knowledge, which is system and version specific. Usually, procedural command knowledge occupies the bulk of the teaching/learning activities in a MCAD course. However, this approach does not provide sufficient strategic knowledge, which is associated to the election of the proper modeling strategies. The concept of quality in the context of MCAD systems is also omitted. In this context, the understanding of the design intent concept by the trainee is critical to develop strategic knowledge of the MCAD tool.

Research has been performed on methods to increase the amount of design intent available for communication, with much of this effort targeted at beginning CAD learners. Condoor states that historically there was one correct depiction of an artifact [22], but with CAD, that artifact may be created using several different approaches, with some techniques being superior in that they more successfully reflect design intent. He determined that there is a substantial connection between the methodology used to create models and the inherent design intent and proposed a procedure to instruct CAD learners to better reflect design intent by subdividing assemblies into parts, and parts into specific entities; identification of symmetry; proper datum plane orientation; design sequence; and hypothetical changes [22].

Hartman, in a two-part study attempting to determine how experienced CAD designers achieved their current level of expertise, states that new CAD learners need curriculum that provides instances where models are created, altered, and model geometry can be manipulated so that they can be adequately prepared for real-life design complexity. Curricular exercises need to be created so that the

correctness and acceptability of an artifact can be related to the model's response to future design changes, both expected and unexpected [31-32].

Johnson and Diwakaran claim that while rapid model creation is valued, creating designs quickly adversely affects design intent and model perception [41]. They assert that the quality of a model should correlate with the amount of time needed for revision, which attempts in some way to quantify design intent and its communication between users. In a continuation of their research, Diwakaran and Johnson conclude that CAD models must be easy to change so that design alterations in the product development cycle are accomplished quickly [25]. It was determined that using simpler features increases the time required to model the original artifact, but increases the reuse of the model in future incarnations. Additionally, simple features, along with the use of reference datum and correct feature sequence increase model understanding when undergoing alteration by secondary users. Feature alteration and reuse is positively correlated with model perception.

Similarly, feedback and evaluation have also received attention. Leahy suggests that well-timed feedback of student performance is needed so that students can incorporate best practices for design intent [47]. He suggests that feedback be non-graded in order to encourage students to strive for deeper knowledge instead of being motivated exclusively by higher marks [47]. Ramos-Barbero and Garcia-Garcia echo a similar pedagogical philosophy, stating that student errors should not be considered failure, but a natural part of the learning process in that it highlights the importance of design methods and standards when using CAD [61].

Proper model assessment for design intent communication is an arduous task, especially for large class environments. Branoff and Wiebe claim that evaluation of student work in order to assess for proper levels of design intent requires accessing student models, which is a time consuming task and oftentimes leads to examination of the hard copy [10]. To alleviate this problem, tools to convey feedback and/or evaluation have been suggested. Baxter and Guerri developed a method to automate the assessment of CAD models and give students instantaneous evaluation [6]. Macros were written and used in conjunction with the Application Programming Interface (API) associated with the CAD software to facilitate the uploading of models to a database. The API facilitates a grading program that compares data from the student files to a master model provided by the instructor. But this approach hardly evaluates the amount of design intent conveyed by the CAD model.

Kirstukas developed a computer program that evaluates the geometry and alterability of student solid models [44]. This program compares student models against an instructor-provided one, deducting points for unused sketches, non-united bodies, and banned constraints while calculating various mass properties [44]. But as with earlier attempts at automating model assessment, design intent and how elegantly the artifact was constructed are not extracted.

Irwin examined what he named scaffolding techniques (mentoring students toward finding solutions) in a senior-level design course to optimize CAD model usability [36]. Constant values in the CAD model were replaced with expressions, which drive design intent, allowing for increased flexibility of design exploration. This approach is extremely valuable because it emphasizes the importance of requiring models to be controlled by parameters (not just linear dimensions) to drive design intent and allow for increased flexibility of design exploration [36].

Ramos-Barbero and colleagues determined that students with stronger spatial vision applied design intent strategies better [62]. They also state that CAD model alteration should be integrated early in CAD instruction so learners will understand appropriate modeling schemes, while additionally calling for improved design intent rules for assemblies [62].

Camba and colleagues examined different methods to create reusable 3D models [13]. They found that "Horizontal" modeling provides for easy alteration because features are independent elements, but that this method is not the most intuitive strategy and describe it as producing the most flexible models, but reduces the functionalities that make the model parametric [13]. They further state that "Explicit References" modeling provides for simple models but are difficult to model and "Resilient" modeling is effective, in spite of reference nodes needed to reduce dependencies [13]. In a more detailed examination, these different modeling methodologies were studied to examine CAD reusability [12]. "Horizontal" modeling minimizes CAD repair by removing parent/child dependencies between features, "Explicit References" modeling minimizes the number of constraints linked to existing geometries by managing functional references, and "Resilient" modeling manages the sequence of the design tree by organizing the features by purpose and priority [12]. The researchers

found that “Resilient” modeling was most effective, although the level of CAD expertise of the study population (students) could have affected the results [12].

Goodrich defined rubrics as assessment tools that specify important curricular concepts as well as gradations between quality levels [30]. Devine and Laingen implemented an assessment scheme that utilized grading rubrics, feedback, and model manipulation to verify design intent [24]. Company et al. state that students need explicit procedures and metrics to assist them in evaluating their performance and describe an expand-contract approach to convey quality-oriented strategies to CAD trainees by embedding quality criteria into rubrics so as to force CAD trainees to understand them early in their instruction [20-21]. In these rubrics, students’ work (a CAD model or assembly) is broken down into its components, that are checked against quality dimensions (conveyed as competences), and later measured through evidences or “assertions [20].” Design intent is addressed in one of the dimensions covered by the rubrics proposed by these authors.

The catalogue of methods utilized to increase the amount of design intent is incomplete and will remain so. Nevertheless, detecting as much common intent as possible is still feasible and useful. Feedback and assessment of the design intent conveyed by a CAD model is also an open problem. Based on current research, the authors believe rubrics and assertion maps are a promising approach, especially when specific quality dimensions are related to the proper communication of design intent. In some cases, the process of validating assertions can be automated, which provides new opportunities in the field of intelligent tutoring systems applied to CAD learning.

4 CONCLUSIONS AND FUTURE WORK

Although design rationale is a well-established field of study, in the context of MCAD systems, design intent remains a complex concept, with different visions and approaches available in the scientific literature. Design intent is commonly, but not always, understood to describe a model’s anticipated behavior once it undergoes alteration. There is a consensus that modeling tools and strategies greatly influence design intent communication. There is also agreement in the convenience of expressing design intent through proper modeling strategies, especially when beginners are learning to model.

Strategies and approaches aimed at improving expression of design intent into CAD models to enhance their quality, together with metrics aimed at evaluating its efficiency, are now receiving some attention. It is becoming evident that guidance aimed at specific design intent instruction is required, since it has been argued in this paper that enhancing design intent conveyed through CAD models may be performed at three different levels (sketch constraints, relationships between modeling operations, and the modeling operations themselves), which have different advantages and disadvantages that must be balanced to get an agreement which allows for selecting the best modeling strategy.

Research shows that rubrics can be a useful tool to facilitate standardized design intent communication. Rubrics are important not only for assessment, but also for communication of expectations. Of current interest is how to define qualities of design intent (and model quality) in such a manner that lends itself to easy assessment. More precise definitions of these terms are vital to any productive research being accomplished. The authors envision further development of these concepts to construct assessment rubrics with the goal of standardizing such definitions and assessment strategies. These rubrics must be adaptive towards the individual and his state of knowledge and other preferences (rubrics change in a system-driven base). They must also be adaptable, as their personalization must be controlled and steered by the user (i.e., user-driven). It is the authors’ conviction that CAD model quality should not be a correlative goal only to be attempted after basic skills are cultivated, but a major goal from the inauguration of instruction.

REFERENCES

- [1] Anderson, B.; Ansaldi, S.: ENGEN Data Model: a neutral model to capture design intent, Proceedings of the Tenth International IFIP WG Conference, Trento, Italy, September 9-12, 1998.

- [2] Anthony, L.; Regli, W.C.; John, J.E.; Lombeyda, S.V.: An approach to capturing structure, behavior, and function of artifacts in computer-aided design, *Journal of Computing and Information Science in Engineering*, 1(2), 2001,186-192. <https://doi.org/10.1115/1.1385826>
- [3] Ault, H.K.: Using geometric constraints to capture design intent, *Journal for Geometry and Graphics*, 3(1), 1999, 39-45.
- [4] Ault, H.K.: 3-D geometric modeling for the 21st Century, *Engineering Design Graphics Journal*, 63(2), 1999, 33-42.
- [5] Ault, H.K; Giolas, D.T.: An investigation of solid modeling practices in industry, *Engineering Design Graphics Journal*, 69(1), 2005, 34-43.
- [6] Baxter, D.H.; Guerci, M.J.: Automating an introductory computer aided design course to improve student evaluation, *Proceedings of the 2003 ASEE Annual Conference & Exposition*, Nashville, Tennessee, June 22-25, 2003.
- [7] Bodein, Y.; Rose, B.; Caillaud, E.: Explicit reference modeling methodology in parametric CAD system, *Computers in Industry*, 65(1), 2014, 136-147. <https://doi.org/10.1016/j.compind.2013.08.004>
- [8] Bracewell, R.; Wallace, K.; Moss, M.; Knott, D.: Capturing design rationale, *Computer-Aided Design*, 41(3), 2009, 173-86. <https://doi.org/10.1016/j.cad.2008.10.005>
- [9] Branoff, T.J.; Hartman, N.W.; Wiebe E.N.: Constraint-based, three-dimensional solid modeling in an introductory engineering graphics course: re-examining the curriculum, *Engineering Design Graphics Journal*, 66(1), 2002, 5-10.
- [10] Branoff, T; Wiebe, E.: Face-to-face, hybrid, or online? Issues faculty face redesigning an introductory engineering graphics course, *Engineering Design Graphics Journal*, 73(1), 2009, 25-31.
- [11] Burge, J.; Brown, D.C.: Design Rationale Types and Tools, AI in Design Group, Technical Report, Worcester Polytechnic Institute, Computer Science Dept., 1998.
- [12] Camba J.; Contero M.; Company P.: Parametric CAD modeling: an analysis of strategies for design reusability, *Computer-Aided Design*, Vol 74, 2016,18-31. <https://doi.org/10.1016/j.cad.2016.01.003>
- [13] Camba J.; Contero M.; Johnson M.; Company P.: Extended 3D annotations as a new mechanism to explicitly communicate geometric design intent and increase CAD model reusability, *Computer-Aided Design*, Vol. 57, 2014, 61-73. <https://doi.org/10.1016/j.cad.2014.07.001>
- [14] Camba, J.; Cosin, A.; Contero, M.: An evaluation of formal strategies to create stable and reusable parametric feature-based 3D models, *Proceedings of the ASME 2014 International Mechanical Engineering Congress and Exposition*, Montreal, Quebec, Canada, November 8-13, 2014. <https://doi.org/10.1115/imece2014-37859>
- [15] Chandrasegaran, S. K.; Ramani, K.; Sriram, R. D.; Horváth, I.; Bernard, A.; Harik, R. F.; Gao, W.: The evolution, challenges, and future of knowledge representation in product design systems,*Computer-aided design*, 45(2), 2013, 204-228. <https://doi.org/10.1016/j.cad.2012.08.006>
- [16] Chang, K.H.: *Product design modeling using CAD/CAE*, Amsterdam, Elsevier, 2014.
- [17] Chen, X.; Hoffman, C.M.: Design compilation of feature-based and constraint-based CAD, *Proceedings of the third ACM Symposium on Solid Modeling and Applications* (pp. 13-19), ACM, 1995. <https://doi.org/10.1145/218013.218021>
- [18] Chester, I.: 3D-CAD: modern technology-outdated pedagogy?, *Design and Technology Education: an International Journal*, 12(1), 2008, 7-9.
- [19] Choi, G.H.; Mun, D.; Han, S.: Exchange of CAD part models based on the macroparametric approach, *International Journal of CAD/CAM*, 2(1), 2002, 13-21.
- [20] Company P.; Contero M.; Otey J.; Plumed R.: Approach for developing coordinated rubrics to convey quality criteria in MCAD training, *Computer-Aided Design*, Vol. 63, 2015, 101-117. <https://doi.org/10.1016/j.cad.2014.10.001>
- [21] Company, P.; Contero, M.; Salvador-Herranz, G.: Testing rubrics for assessment of quality in CAD modeling, *Research in Engineering Education Symposium* (pp. 107-112), Kuala, Lumpur, Malaysia, July 4-6, 2013.
- [22] Condoor, S.S.: Integrating design in engineering graphics courses using feature-based, parametric solid modeling, *Proceedings of the 29th ASEE/IEEE Frontiers in Education Conference* (pp. 12d2-13) San Juan, Puerto Rico, November 10-13, 1999. <https://doi.org/10.1109/fie.1999.841661>

- [23] Dassault Systemes, SolidWorks Help: Design Intent. Retrieved from http://help.solidworks.com/2015/English/solidworks/acadhelp/c_design_intent.htm, accessed 31 July 2015.
- [24] Devine, K.L.; Laingen, M.A.: Assessing design intent in an introductory-level engineering graphics course, Proceedings of the 68th Mid-Year Conference of the ASEE Engineering Design Graphics Division (pp. 59-63), Worcester, Massachusetts, October 20-22, 2013.
- [25] Diwakaran, R.P.; Johnson, M.D.: Analyzing the effect of alternative goals and model attributes on CAD model creation and alteration, Computer-Aided Design, 44(4), 2012, 343-353. <https://doi.org/10.1016/j.cad.2011.11.003>
- [26] Dorribo-Camba, J.; Contero, M.: Integration of model-based design annotations in product lifecycle management systems to facilitate design intent communication, Proceedings of the 10th International Symposium on Tools and Methods of Competitive Engineering (pp. 1-10), Budapest, Hungary, May 19-23, 2014.
- [27] Fu, M.W.; Ong, S.K.; Lu, W.F.; Lee, I.B.H.; Nee, A.Y.C.: An approach to identify design and manufacturing features from a data exchanged part model, Computer-Aided Design, 35(11), 2002, 979-993. [https://doi.org/10.1016/S0010-4485\(02\)00160-4](https://doi.org/10.1016/S0010-4485(02)00160-4)
- [28] Gerbino, S.: Tools for the interoperability among CAD systems, XIII ADM—XV INGEGRAP International Conference on Tools and Methods Evolution in Engineering Design, 2003.
- [29] González-Lluch, C.; Company, P.; Contero, M.; Camba, J. D.; Plumed, R.: A survey on 3D CAD model quality assurance and testing tools, Computer-Aided Design, 83(2017), 2016, 64-79.
- [30] Goodrich, H.: Understanding rubrics, Educational Leadership, 54, 1997, 14-17.
- [31] Hartman, N.W.: The development of expertise in the use of constraint-based CAD tools: examining practicing professionals, Engineering Design Graphics Journal, 68(2), 2004, 4-26.
- [32] Hartman, N.W.: Defining expertise in the use of constraint-based CAD tools by examining practicing professionals, Engineering Design Graphics Journal, 69(1), 2005, 6-15.
- [33] Henderson, M.R.: Representing functionality and design intent in product models, Proceedings on the second ACM Symposium on Solid Modeling and Applications (pp. 387-396), Montreal, Canada. May 19-21, 1993. <https://doi.org/10.1145/164360.164485>
- [34] ISO: ISO 10303-55, Industrial automation systems-Product data representation and exchange-Part 55: Integrated generic resource: Procedural and hybrid representation, Organisation Internationale de Normalisation, Geneve, Suisse, 2005.
- [35] ISO: ISO 10303-108, Industrial automation systems and integration-Product data representation and exchange-Part 108: Integrated application resource: Parameterization and constraints for explicit geometric product models, Organisation Internationale de Normalisation, Geneve, Suisse, 2005.
- [36] Irwin, J.: Wind turbine blade CAD models used as scaffolding technique to teach design engineers, Engineering Design Graphics Journal, 77(2), 2013, 1-17.
- [37] Iyer, G.R.; Mills, J.J.: Design Intent in 2D CAD: Definition and Survey, Computer Aided Design and Applications, 3(1-4), 2006, 259-267. <https://doi.org/10.1080/16864360.2006.10738463>
- [38] Jackson, C.; Buxton, M.: The design reuse benchmark report, Seizing the opportunity to shorten product development, Boston, Aberdeen Group, 2007.
- [39] Jackson, C.; Prawel, D.: The 2013 state of 3D collaboration and interoperability report, Page 7, Lifestyle Insights and Longview Advisors, 2013.
- [40] Jarczyk, A.P.; Loffler, P.; Shipman F.M.: Design rationale for software engineering: A survey, Proceedings of the 25th Hawaii International Conference on System Sciences (Vol. 2. pp. 577-586), IEEE, 1992. <https://doi.org/10.1109/hicss.1992.183309>
- [41] Johnson, M.D.; Diwakaran, R.P.: Assessing the effect of incentive on computer-aided design intent. Proceedings of the ASME 2009 International Design Engineering Technical Conference & Computers and Information in Engineering Conference (pp. 1-10), San Diego, California, August 30-September 2, 2009. <https://doi.org/10.1115/detc2009-86644>
- [42] Karsenty, L.: An empirical evaluation of design rationale documents. Proceedings of the ACM CHI 96 Annual Conference on Computer-Human Interaction (pp. 150-156), Vancouver, BC Canada, April 13-18, 1996. <https://doi.org/10.1145/238386.238462>
- [43] Kimura, F.; Suzuki, H.: A CAD system for efficient product design based on design intent, CIRP Annals-Manufacturing Technology, 38(1), 1989, 149-152. [https://doi.org/10.1016/S0007-8506\(07\)62672-9](https://doi.org/10.1016/S0007-8506(07)62672-9)

- [44] Kirstukas, S.J.: Development and evaluation of a computer program to assess student CAD models, Proceedings of ASEE's 123rd Annual Conference and Exposition, New Orleans, LA, June 26-29, 2016. <https://doi.org/10.18260/p.26781>
- [45] Kunz, W.; Rittel, H.: Issues as Elements of Information Systems (Vol. 131), Berkeley, California: Institute of Urban and Regional Development, University of California, 1970.
- [46] Laursen, E.; Møller, L.: Collaboration between Industrial Designers and Design Engineers-Comparing the Understanding of Design Intent, Studies in health technology and informatics, 217, 2015, 367.
- [47] Leahy, K.: Promoting best practice design intent in 3D CAD modelling: feedback as a constructivist paradigm of teaching and learning, Proceedings of the ASEE EDGD 67th Midyear Meeting (pp. 59-66), Limerick, Ireland. November 18-20, 2012.
- [48] Lee, J.: Design Rationale Systems: Understanding the Issues, IEEE Expert, 12(3), 1997, 78-85. <https://doi.org/10.1109/64.592267>
- [49] Lee, J.; Lai, K.: What's in design rationale? Human-Computer Interaction, 6(3-4), 1991, 251-280. https://doi.org/10.1207/s15327051hci0603&4_3
- [50] Li, M.; Langbein, F.C.; Martin R.R.: Detecting design intent in approximate CAD models using symmetry, Computer-Aided Design, 42(3), 2010, 183-201. <https://doi.org/10.1016/j.cad.2009.10.001>
- [51] MacLean, A.; Young, R.M.; Bellotti, V.M.; Moran, T.P.: Questions, options, and criteria: elements of design space analysis, Human-computer interaction, 6(3-4), 1991, 201-250. https://doi.org/10.1207/s15327051hci0603&4_2
- [52] MacLean, A.; Young, R.M.; Moran, T.P.: Design rationale: the argument behind the artifact, In Bice, K. and Lewis, C.H., (eds.), Proceedings of the ACM CHI 89 Human Factors in Computing Systems Conference (pp. 247-252), Austin, Texas, April 30-June 4, 1989. <https://doi.org/10.1145/67449.67497>
- [53] Mandorli, F.; Otto, H. E.; Raffaelli, R.: Explicit 3D functional dimensioning to support design intent representation and robust model alteration, Computer-Aided Design and Applications, 13(1), 2016, 108-123. <https://doi.org/10.1080/16864360.2015.1059201>
- [54] Mostow, J.: Toward better models of the design process, AI magazine, 6(1), 1985, 44-57.
- [55] Mun, D.; Han, S.; Kim, J.; Oh, Y.: A set of standard modeling commands for the history-based parametric approach, Computer-Aided Design, 35(13), 2003, 1171-1179. [https://doi.org/10.1016/S0010-4485\(03\)00022-8](https://doi.org/10.1016/S0010-4485(03)00022-8)
- [56] Owensby, J.E.; Summers, J.D.: Assembly Time Estimation: Assembly Mate Based Structural Complexity Metric Predictive Modeling, Journal of Computing and Information Science in Engineering, 14(1), 2014, 011004. <https://doi.org/10.1115/1.4025808>
- [57] Pena-Mora, F.; Sriram, D.; Logcher, R.: SHARED-DRIMS: SHARED Design Recommendation-Intent Management System, Enabling Technologies: Infrastructure for Collaborative Enterprises, Proceedings, Second Workshop, 1993, 213-22.
- [58] Plumed, R.; Varley, P.; Company, P.: Features and design intent in engineering sketches, In Intelligent Computer Graphics, 2012, (77-106), Springer Berlin Heidelberg.
- [59] Pratt, M.J.; Anderson, B.D.; Ranger, T.: Towards the standardized exchange of parameterized feature-based CAD models, Computer-Aided Design, 37(12), 2005, 1251-1265. <https://doi.org/10.1016/j.cad.2004.12.005>
- [60] PTC Creo: Designing with intent, Retrieved from <http://creo.ptc.com/2010/12/02/designing-with-intent/>, Accessed 31 July 2015.
- [61] Ramos-Barbero, B.; Garcia-Garcia, R.: Strategic learning of simulation and functional analysis in the design and assembly of mechanisms with CAD on a professional master's degree course, Computer Applications in Engineering Education, 19(1), 2009, 146-160. <https://doi.org/10.1002/cae.20300>
- [62] Ramos-Barbero, B.; Melgosa-Pedrosa, C.; Zamora-Samperio, R.: Learning CAD at university through summaries of the rules of design intent, International Journal of Technology and Design Education, 2016,1-18.
- [63] Regli, W.C.; Hu, X.; Atwood, M.; Sun, W.: A survey of design rationale systems: approaches, representation, capture and retrieval, Engineering with Computers, 16(3-4), 2000, 209-235. <https://doi.org/10.1007/PL00013715>

- [64] Requicha, A.A.G.; Rossignac, J.R.: Solid modeling and beyond, IEEE Computer Graphics and Communications, 12(5), 1992, 31-44. <https://doi.org/10.1109/38.156011>
- [65] Rynne, A.; Gaughran, W.: Cognitive modeling strategies for optimum design intent in parametric modeling, Computers in Education Journal, 18(1), 2008, 55-68.
- [66] Shih, C.H.; Anderson, B.: A design/constraint model to capture design intent, Proceedings of the fourth ACM Symposium on Solid Modeling and Applications (pp. 255-264), ACM,1997. <https://doi.org/10.1145/267734.267802>
- [67] Shum, S.; Hammond, N.: Argumentation-Based Design Rationale: From Conceptual Roots to Current Use, Tech. Report EPC-1993-106, Rank Xerox Research Centre, Cambridge, 1993.
- [68] Siemens: (2015). Designing products in NX, Retrieved from http://www.plm.automation.siemens.com/en_us/products/nx/, Accessed 31 July 2015.
- [69] Sim, S.; Duffy, A.: A New Perspective to Design Intent and design Rationale, Artificial Intelligence in Design Workshop Notes for Representing and Using Design Rationale, 1518 August, 1994, pp. 4-12.
- [70] Srinivasan, V.; Chakrabarti, A.; Lindemann, U.: (2012). A framework for describing functions in design. Proceedings of the 12th International Design Conference (pp. 1111-1121).
- [71] Szykman, S., Sriam, R.D., & Regli, W.C.: The role of knowledge in next-generation product development systems, Journal of Computing and Information Science in Engineering, 1(1), 2001, 3-11. <https://doi.org/10.1115/1.1344238>
- [72] Ullman, D.G.: Toward the ideal mechanical engineering design support system, Research in Engineering Design, 13(2), 2002, 55-64. <https://doi.org/10.1007/s00163-001-0007-4>
- [73] Wang, Z. S.; Tian, L.; Wu, Y. H.; Liu, B. B.: Personalized knowledge push system based on design intent and user interest, Proceedings of the Institution of Mechanical Engineers, Part C: Journal of Mechanical Engineering Science, 2015.
- [74] Wiebe, E.N.: Future applications of geometry and graphics, Engineering Design Graphics Journal, 63(2), 1999, 13-20.
- [75] Will, P.M.: Simulation and modeling in early concept design: an industrial perspective, Research in Engineering Design, 3(1), 1991, 1-13. <https://doi.org/10.1007/BF01580064>
- [76] Zhang, Y.; Luo, X.: Design intent information exchange of feature-based CAD models, Proceedings of the World Congress on Computer Science and Information Engineering (pp. 11-15), Los Angeles, California, March 31-April 2, 2009. <https://doi.org/10.1109/csie.2009.536>
- [77] Zhang, Y.; Luo, X.; Li, J.; Buis J.J.: A semantic representation model for design rationale of products, Advanced Engineering Informatics, 27(1), 2013, 13-26. <https://doi.org/10.1016/j.aei.2012.10.005>