



Worked example: checking a truss member in compression

Apellidos, nombre	Guardiola VÍllora, Arianna (aguardio@mes.upv.es)
Departamento	Mecánica del Medio continuo y Teoría de Estructuras
Centro	Universitat Politècnica de València

1 Summary

This document shows how to check a truss member in compression designed with a hot rolled hollow rectangular cross section considering the Spanish Code DB SE A.

The geometry of the steel frame and the bracing system shown in the design must be taking into account in the analysis and design.

2 Introduction

Given the Steel frame shown in figure 1, it is requested to check the upper chord BC designed with a S 275 hot rolled hollow rectangular cross section # 60.80.5 explaining which one is the best orientation of the cross section. Note: $\alpha = 60^\circ$

To understand the steel structure performance, a 3D model showing the bracing systems can be seen in figure 2.

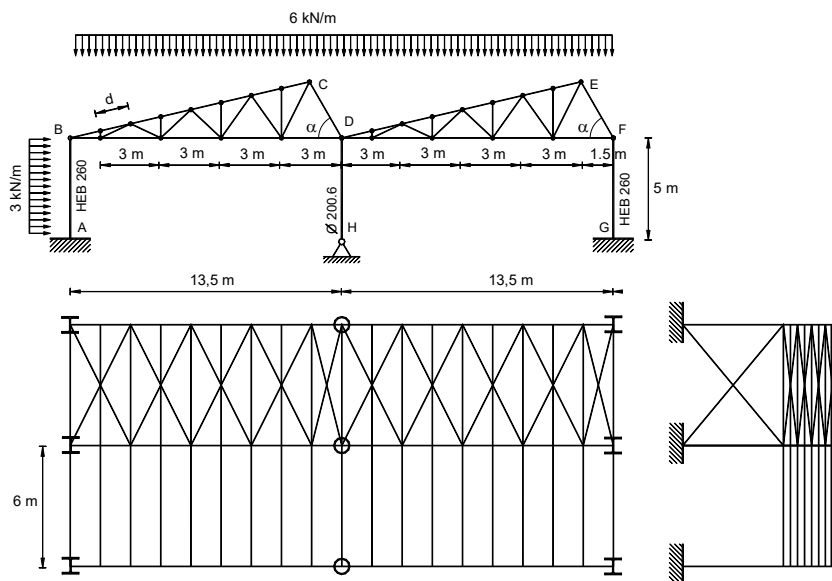

figure 1. Front, top and lateral views

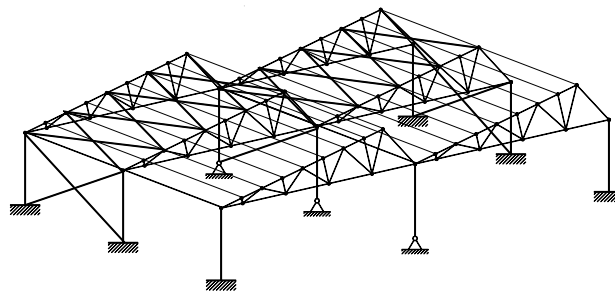

figure 2. 3D model showing the bracing Systems

3 Aims

At the end of this document, the student will be able to:

- Analyse a simple truss using the method of sections
- Obtain the upper chord effective lengths when checking in-frame buckling phenomena
- Obtain the upper chord effective lengths when checking out-of-frame buckling phenomena
- Explain which position of the rectangular cross section is the optimal solution considering the obtained effective lengths
- Check if the designed cross section fulfils the Spanish Code conditions for members in compression

4 Worked example

4.1 Geometric properties of the cross section

Geometric properties are shown in table 1

**RECTANGLE
HOLLOW
CROSS SECTIONS**

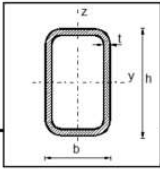

Cross section				M Kg/m	Geometric properties												
	b mm	h mm	t mm		painting surface per unit length and unit mass		A mm ²	I _y mm ⁴ (x10 ⁶)	W _{el,y} mm ³ (x10 ³)	W _{pl,y} mm ³ (x10 ³)	i _y mm	A _{v,y} mm ²	I _z mm ⁴ (x10 ⁶)	W _{el,z} mm ³ (x10 ³)	W _{pl,z} mm ³ (x10 ³)	i _z mm	A _{v,z} mm ²
					m ² /m	m ² /T											
60-80-5	60	80	5	10,5	0,283	26,9	1340	1,13	28,3	34,8	29,1	765	0,710	23,7	28,3	23,0	575

Table 1. Geometric properties of the cross section

4.2 Upper chord internal forces

To analyse the steel truss model in figure 3, the continuous vertical load has been transformed into concentrated loads at nodes, considering also vertical reactions at B and D ends obtained in Equation 1

$$R_b = R_D = \frac{q_v \cdot L}{2} = \frac{6 \cdot 13.5}{2} = 40.5 \text{ kN}$$

Equation 1. Reactions at ends

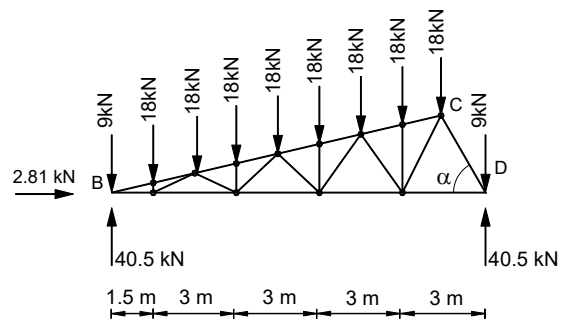

Figure 3. Concentrated loads and reactions

As it is not known in which part of the upper chord the axial force value is greater, both sections at the ends are analysed.

Passing the cutting plane on the right of B end, the unknown internal forces are named N_1 and N_2

Considering the vertical forces equilibrium equation (equation 2):

$$\sum F_v = 0 \rightarrow 40.5 - 4.5 + N_1 \cdot \sin \alpha = 0$$

Equation 2. Equilibrium equation

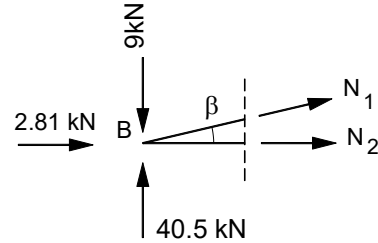

Figure 4. Cutting plane

And, as can be seen in figure 5, considering $\text{tg } 60^\circ = \frac{h}{1.5} \rightarrow h \approx 2.6 \text{ m}$

then $\beta = \arctg \frac{h}{12} \rightarrow \beta \approx 12.21^\circ$ and therefore $N_1 = \frac{-36}{\sin 12.21^\circ} = -172.2 \text{ kN}$

Taking into account that, although in figure 4 both unknown were tension forces (positive) the obtained value for N_1 is negative, which means that the member is in compression.

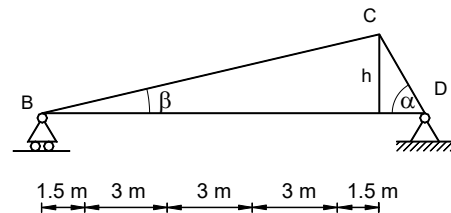

Figure 5. Geometry

Passing the cutting plane on the left of D end (figure 6) and considering the bending moments equilibrium equation (Equation 3)

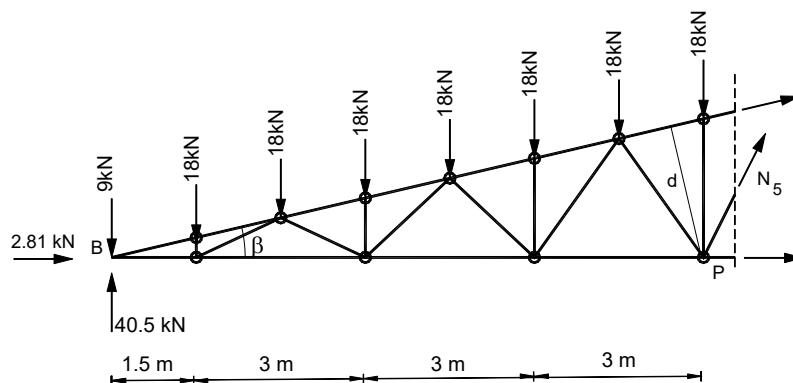

Figure 6. cutting plane and forces

$$\sum M_p = 0 \rightarrow$$

$$40.5 \cdot 10.5 - 4.5 \cdot 10.5 - 9 \cdot 9 - 9 \cdot 7.5 - 9 \cdot 6 - 9 \cdot 4.5 - 9 \cdot 3 - 9 \cdot 1.5 + N_3 \cdot d = 0$$

Equation 3. Equilibrium equation

Where $\sin \beta = \frac{d}{10.5} \rightarrow d = 2.22 \text{ m}$ (see Figure 6) substituting in equation 3

$$N_3 = \frac{425.25 - 47.25 - 81 - 67.5 - 54 - 40.5 - 27 - 13.5}{2.22} \rightarrow N_3 = -42.56 \text{ kN}$$

Being N_3 negative, it means that the member is in compression.

As N_3 is the maximum value therefore $N_{Ed} = 172.2 \text{ kN}$

4.3 Resistance condition

The criterion to be satisfied, for class of cross section 1, 2 or 3 is shown in equation 4, where $N_{pl,Rd}$ is the design plastic resistance against axial forces, which value is obtained in equation 5

$$N_{Ed} \leq N_{pl,Rd} \quad \text{Equation 4. Resistance condition}$$

$$N_{pl,Rd} = A \cdot \frac{f_y}{\gamma_{M0}} \quad \text{Equation 5. Design plastic resistance}$$

Being A the area of the cross section, f_y the yield stress and γ_{M0} the partial factor.

The cross section #60.80.5 is class 1 if $\frac{c}{t} \leq 33 \cdot \varepsilon$ Equation 6. Class 1 condition

Being (see table 1) $\frac{c}{t} = \frac{80 - 2 \cdot 1.5 \cdot 5}{5} = 13 \leq 33 \cdot \varepsilon = 33 \cdot \sqrt{\frac{235}{275}} = 30.5 \rightarrow$ the cross section is class 1

Therefore $N_{pl,Rd} = 1340 \cdot \frac{275}{1.05} = 350.952 \text{ N} > N_{Ed} = 172.200 \text{ N}$ the cross section fulfils the resistance condition.

4.4 Buckling condition

The criterion to be satisfied, for class of cross section 1, 2 or 3 is shown in equation 7, where $N_{b,Rd}$ is the design buckling resistance of the compression member, χ_{min} is the reduction factor for the relevant buckling mode (it depends on the buckling length and the geometry of the cross-section) and γ_{M1} the partial factor for buckling conditions.

$$N_{Ed} \leq N_{b,Rd} = \frac{\chi_{min} \cdot A \cdot f_y}{\gamma_{M1}} \quad \text{Equation 7. Buckling condition}$$

For upper and bottom chord members in trusses, the effective length L_k is:

- When checking in-frame plane buckling phenomena, the effective length is the distance between nodes (real length, equal to d in figure 1)
- When checking out of frame plane buckling phenomena, the effective length is the distance between restrained joints (twice d , due to the bracing system shown in figure 1)

Being $\cos \beta = \frac{1.5}{d} \rightarrow d = 1.534 \text{ m}$

Knowing the effective length in both planes, the cross section can be oriented.

4.4.1 Effective lengths and orientation of the cross section:

It is advisable to place the member with the greater second moment of area in the plane where the effective length is greater too.

So, the orientation of the cross section will be that shown in figure 7.

Therefore, the effective buckling lengths are:

Buckling about the y axis (orthogonal to y axis or out of plane) $L_{ky} = 2 \cdot 1534 = 3068 \text{ mm}$

Buckling about the z axis (orthogonal to z axis or in plane buckling) $L_{kz} = 1534 \text{ mm}$

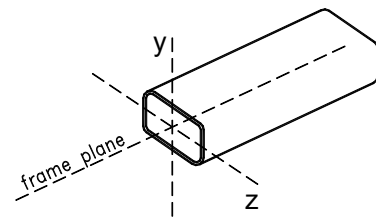

Figure 7. orientation of the cross section

4.4.2 Slenderness and non-dimensional slenderness:

- Slenderness ratio:

Buckling about the y axis (orthogonal to y axis):

$$\text{Slenderness about y axis: } \lambda_y = \frac{L_{k,y}}{i_y} = \frac{3068}{29,1} = 105.42$$

Buckling about the z axis (orthogonal to z axis):

$$\text{Slenderness about z axis: } \lambda_z = \frac{L_{k,z}}{i_z} = \frac{1534}{23} = 66.6$$

As $\lambda_y > \lambda_z$, and the reduction factor for buckling in both planes is obtained in curve a because it is a hot rolled hollow cross section, as can be seen in table 1.

The maximum non dimensional slenderness will be $\overline{\lambda}_y$, which means that the member will buckle about the y axis.

- Non dimensional slenderness: (NOTE: non dimensional slenderness is rounded up)

$$\text{Buckling about the y axis (orthogonal to y axis) } \overline{\lambda}_y = \frac{\lambda_y}{\lambda_R} = \frac{105.42}{86.8} = 1.21 \approx 1.25$$

- Reduction factor value:

The reduction factor value is obtained in table 2, considering the average value for $\bar{\lambda}_y = 1.20$ and $\bar{\lambda}_y = 1.30$

$$\text{Therefore } \bar{\lambda}_y \approx 1.25 \xrightarrow{\text{curve a}} \chi_y = \frac{0.53 + 0.47}{2} = 0.5$$

Cross section	Steel grade	S235 a S355		S450	
	Buckling about the axis (\perp)	y	z	y	z
Rolled I- sections 	$h/b > 1,2$: $t_f \leq 40 \text{ mm}$ $40 \text{ mm} < t_f \leq 100 \text{ mm}$	a	b	a₀	a₀
	$h/b \leq 1,2$: $t_f \leq 100 \text{ mm}$ $t_f > 100 \text{ mm}$	b	c	a	a
Welded I-sections 	$t_f \leq 40 \text{ mm}$	b	c	b	c
	$t_f > 40 \text{ mm}$	c	d	c	d
Welded rolled sections 		c	c	c	c
Hollow sections 	Hot rolled	a	a	a₀	a₀
	Cold formed	c	c	c	c
Welded box sections 	Thick welds and: $a/t > 0,5$ $b/t_f < 30$ $h/t_w < 30$	c	c	c	c
	Other cases	b	b	b	b

Table 1. Selection of buckling curve for a given cross section

$\bar{\lambda}$	Buckling curve				
	a ₀	a	b	c	d
≤ 0,2	1,00	1,00	1,00	1,00	1,00
0,3	0,99	0,98	0,96	0,95	0,92
0,4	0,97	0,95	0,93	0,90	0,85
0,5	0,95	0,92	0,88	0,84	0,78
0,6	0,93	0,89	0,84	0,79	0,71
0,7	0,90	0,85	0,78	0,72	0,64
0,8	0,85	0,80	0,72	0,66	0,58
0,9	0,80	0,73	0,66	0,60	0,52
1,0	0,73	0,67	0,60	0,54	0,47
1,1	0,65	0,60	0,54	0,48	0,42
1,2	0,57	0,53	0,48	0,43	0,38
1,3	0,51	0,47	0,43	0,39	0,34
1,4	0,45	0,42	0,38	0,35	0,31
1,5	0,40	0,37	0,34	0,31	0,28
1,6	0,35	0,32	0,31	0,28	0,25
1,7	0,31	0,30	0,28	0,26	0,23
1,8	0,28	0,27	0,25	0,23	0,21
1,9	0,25	0,24	0,23	0,21	0,19
2,0 ⁽¹⁾	0,23	0,22	0,21	0,20	0,18
2,1 ⁽¹⁾	0,21	0,20	0,19	0,18	0,16
2,2 ⁽¹⁾	0,19	0,19	0,18	0,17	0,15
2,3 ⁽¹⁾	0,18	0,17	0,16	0,15	0,14
2,4 ⁽¹⁾	0,16	0,16	0,15	0,14	0,13
2,5 ⁽²⁾	0,15	0,15	0,14	0,13	0,12
2,6 ⁽²⁾	0,14	0,14	0,13	0,12	0,11
2,7 ⁽²⁾	0,13	0,13	0,12	0,12	0,11
2,8 ⁽²⁾	0,12	0,12	0,11	0,11	0,10
2,9 ⁽²⁾	0,11	0,11	0,11	0,10	0,09
3,0 ⁽²⁾	0,11	0,10	0,10	0,10	0,09

⁽¹⁾ non-acceptable slenderness ratio for principal members
⁽²⁾ non- acceptable slenderness ratio, including bracing systems elements

 Table 2. Reduction factor χ

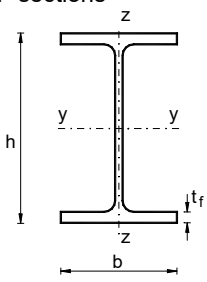
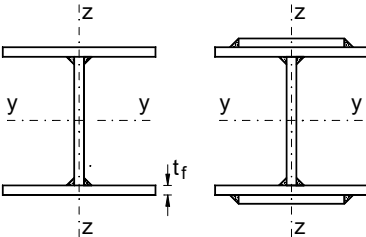
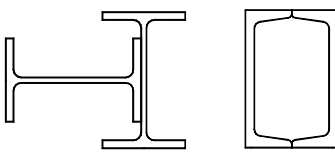
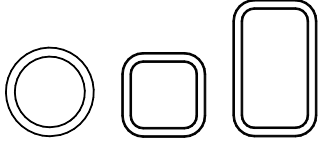
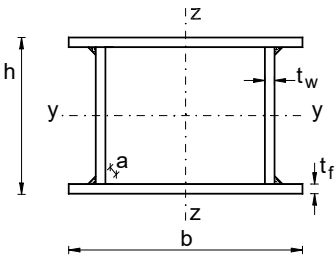
4.4.3 Design buckling resistance:

The design buckling resistance is $N_{b,Rd} = \frac{0.5 \cdot 1340 \cdot 275}{1.05} = 175.476 \text{ N}$

According to equation 7, as $N_{Ed} = 170.2 \text{ kN} < N_{b,Rd} = 175.476 \text{ N}$, the S 275 hot rolled #60·80·5 cross section, fulfils the buckling condition.

4.5 Final design of the upper chord

As the S 275 60·80·5 rectangle hollow cross section, orientated as shown in figure 7, fulfils both conditions: resistance and buckling in compression, the upper chord of the truss can be designed with that cross section.

5 Proposed exercise

It is requested to analyse how the resistance of the proposed cross section will change if the effective length in the out of frame plane were equal to the effective length in the frame plane, as it is shown in figure 8

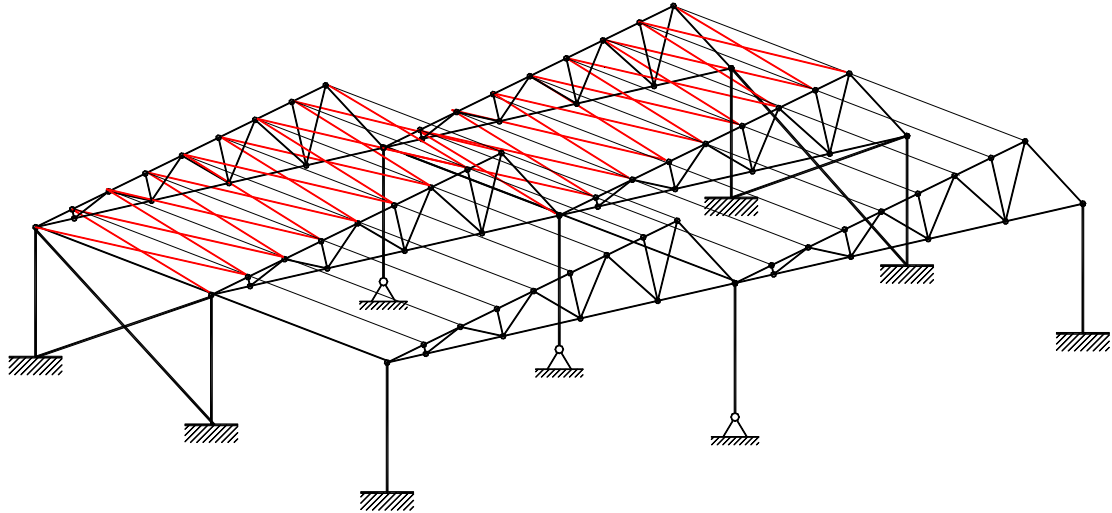

Figure 8. New proposed bracing system

6 Conclusion

This document explains, with a worked example, how to check the upper chord of a truss in compression designed with a hollow cross section.

With this purpose, the student has to follow the following steps:

1. Obtain the internal forces in the analysed member
2. Check the resistance condition
3. Analyse how the frame has been designed considering the bracing systems and its influence in the effective length of the member in every plane.
4. To orientate the cross section according to the global analysis of the whole structure
5. Obtain the slenderness in both planes
6. Analyse if it is necessary to obtain the non-dimensional slenderness in both planes.
7. Obtain the buckling reduction factor in order to calculate the design buckling resistance.

In order to consolidate the application of the method, a variation about the structural organization of the initial exercise is proposed. The solution is explained at the end of this document.

Finally, it is important to point out that the initial design of the cross section is not always going to fulfil all the conditions. In those cases, the cross section must be redesigned and checked until all the conditions are fulfilled.



7 Bibliography

7.1 Books:

Guardiola-Villora, A; Pérez-García, A: "Steel structures. Worked examples according to the Spanish Code", Ed. Universitat Politècnica de València, 2017, chapter 4

7.2 Codes:

Steel structures Spanish code "Documento Básico, Seguridad Estructural, Acero". Ministerio de Fomento 2006. It can be downloaded from:

<https://www.codigotecnico.org/>

7.3 Web sites:

Mathalino, Pinoy Community on engineering Math. "Analysis of Structures". Link:

<https://www.mathalino.com/reviewer/engineering-mechanics/method-sections-analysis-simple-trusses>.

8 Solution of the proposed exercise

Taking into account the value of the effective length in the frame plane, where the maximum non dimensional slenderness is $\overline{\lambda}_y$, meaning that the member will buckle in the frame plane (about the y axis), changing the effective length in the out of frame plane won't change the results.

Therefore, the right answer is that reducing the effective length in the out of frame plane does not improve the buckling resistance of the designed cross section.