



*A non structural vertical closure made entirely of components in hemp and lime.  
(source: Edilcanapa)*

# The rehabilitation of buildings. Reflections on construction systems for the environmental sustainability of interventions.

Stefania De Gregorio<sup>1</sup>

<sup>1</sup> Civil, Building/Architecture and Environmental Engineering, University of L'Aquila

## ABSTRACT

---

The old age and the poor state of repair of the Italian building heritage and the change in the needs and lifestyle of modern society require re-qualitative interventions of building rehabilitation. These operations are environmentally sustainable, favouring the protection of the soil, allowing the grey energy of the materials that make up the building to be depreciated over a greater number of years and which will have sufficient residual performance, also thanks to integration with other components.

In order to safeguard the intrinsic sustainability of the rehabilitation of the building, it is necessary to act in the intervention taking into account its sustainability, considering the life cycle of both the building as a whole together with its specific redevelopment project. Sustainability in the management phase is conditioned by energy efficiency; in the construction and demolition phases, however, it is conditioned both by the construction techniques and the connection methods between the different elements of the construction system, and above all by the choice of its components and materials that make it up. The paper presents as an international best practice a dry construction system made with recycled elements derived from scaffolding and a wet construction system consisting of components in lime and hemp.

---

## KEYWORDS

*sustainable rehabilitation, sustainable constructive systems, natural materials, lime and hemp, scaffolding*

## 1. INTRODUCTION

The rehabilitation of the buildings is a widely discussed topic both in academia and the workplace. The sustainability of interventions is also conditioned by the safeguarding of the territory through the non-utilisation of land additional to that already occupied for the construction of new buildings. According to recent data in Italy<sup>1</sup>, in fact, 7.64% of the national territory is already covered, with an increase in net land cover in 2018 equal to 48 km<sup>2</sup>. At the same time, the analysis of the Italian building stock shows that about 15% of the buildings were built before 1918 and 65% were built before 1975 (Fig.1), i.e. before the introduction of energy saving criteria and anti-seismic regulations by the law. In addition to this, this heritage is, in part, in a poor and very poor state of maintenance<sup>2</sup> and therefore requires interventions aimed at its redevelopment.

In the redevelopment of buildings, the possibility of reusing the building increases the life cycle of the materials with which it is constructed, allowing to depreciate their grey energy over a greater number of years (Cabeza et al, 2014). The rehabilitation of a building compared to a new construction avoids new production of a portion of the material needed constructiong and avoids the landfill of components

that, if integrated with others, still have sufficient residual performance (De Berardinis, 2007).

In addition, changes in society coming from single-parent families, extended families, etc.. and weak geographical boundaries between countries that enables a large number of people to be in constant motion, requires research in the construction of spaces more flexible to the evolution of "liquid modernity" (Bauman, 2013). The Italian building stock, 70% of which is over 30 years old, is no longer adequate to the size and functional requirements currently required by society, with the consequent need to adapt the system of spaces.

Therefore, in light of the current situation, the redevelopment of buildings is a necessary and sustainable operation, but it is necessary to identify methods and strategies in order to increase levels of sustainability of interventions.

## 2. SUSTAINABILITY OF INTERVENTIONS

The sustainability of interventions must take into account the entire life cycle of the building and its three main phases: construction, management and demolition.

In the management phase, for long mistakenly

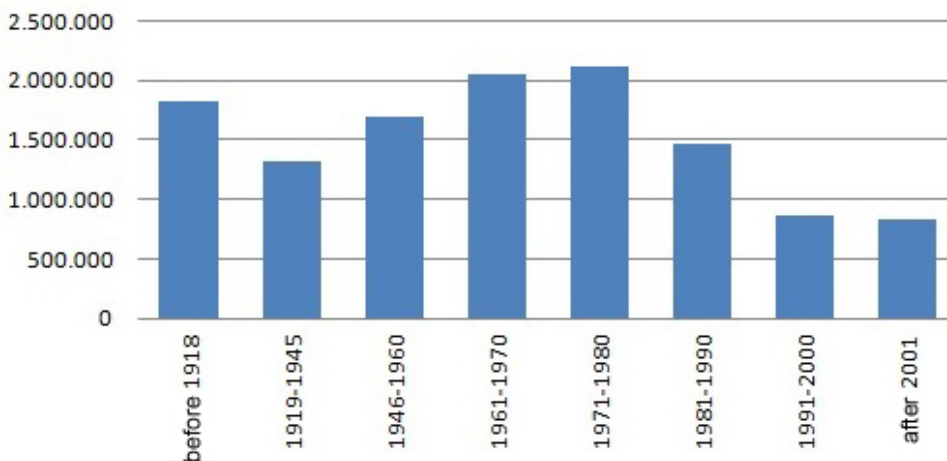

Figure 1.  
Number of buildings by age group in Italy (source: Portal for energy efficiency of existing buildings <http://www.portale4e.it/>).

considered the only focus in the search for sustainability, the building must be energy efficient by balancing the energy consumed with that produced. The energy efficiency project aims to achieve environmental comfort (thermal, luminous and acoustic) at the lowest energy cost (Francese, 2000). It is important to underline the distinction between the energy cost, which only concerns energy, and the environmental cost, which concerns all aspects affecting the environment, including energy. Energy efficiency, in fact, is reasoned from a performance point of view, and the way to achieve performance is channelled through the choice of the construction system (and consequently of the materials/components) which is the result of choices made in the construction/demolition phases.

Consider, for example, the current problems regarding the production and end of life of photovoltaic panels, on the one hand, the construction of the panels involves the use of non-renewable raw materials and on the other hand, considering that the average life of a photovoltaic panel is 30 years, their disposal involves environmentally significant operations.

The achievement of energy efficiency is achieved through (Hegger, 2012):

- the design of the shell, a filter element and the relationship between the internal and external environment,
- the implementation of active and passive bioclimatic strategies,
- the design of efficient plants.

In the construction and demolition phases, the sustainability of the intervention is conditioned by the choice of the construction system and the materials/components (Lavagna, 2008).

The introduction of the concept "a house is a machine for living" (Le Corbusier) has marked the transition from traditional construction techniques to the rationalization of the production process in the construction industry through first of all the prefabrication of components and secondly the assembly in the industry of part or all of the construction system. The standardization of the construction process through dry construction systems has, therefore, allowed productive and consequently economic advantages, increasing the factory phases and thereby reducing and simplifying

the operations on site, lowering the requirement for a specialised workforce, and at the same time, reducing the possibility of errors in the yard.

The reversibility of the intervention also provides advantages in the management phase for the maintenance/ replacement of components.

As a result of the energy and oil crisis of the 1980s, dry construction systems, due to their reversibility and sometimes flexibility, have been recognised as providing a guarantee of sustainability, while wet construction systems, which reflect traditional construction methods and require skilled labour, have been considered unsustainable also in view of their non-reversibility. In fact, non-reversibility not only limits maintenance interventions but also imposes that, at the end of their life-cycle, the waste from demolition cannot be separated into homogeneous product groups.

It should be considered, however, that in reality the lack of sustainability of wet systems does not depend on the construction technique as such, but depends primarily on all of the materials used (generally bricks, concrete and cement mortars, unsustainable materials) and secondly on the impossibility of separating, after demolition, the materials into homogeneous product groups to send them for recycling or to keep intact for reuse.

In fact, analysing the history of construction and in particular of temporariness, which has connotations of reversibility and flexibility (requirements in common with drywall systems), we find examples of wet wall systems with a high level of sustainability. Consider, for example, igloos made through pressed snow components joined together by fresh snow. The sustainability of igloos is guaranteed by its component material, snow, which can be returned to nature and reabsorbed, without producing an environmental impact: the material is "borrowed" from the environment to be returned to it and, in this way, the flows in and out are compensated (Fig.2).

Therefore, in order to guarantee the sustainability of interventions, it is necessary to choose construction systems that do not impact the environment, in which the reversibility and flexibility of the system are studied not only on the construction system as such, but rather on the environment in general and on the territorial context in particular (Imperadori, 2001).



Figure 2.

Construction of igloos

(source: *Inuits* By Frank E. Kleinschmidt - Library of Congress Prints and Photographs Division, Washington, DC 20540. Public Domain).

The sustainability of a construction system can be assessed by considering the existence of the following conditions:

1. the construction system must be made up of materials/ components that have a low or zero environmental impact, to achieve this goal:
  - materials/components should be made with renewable resources or should derive from previous life cycles (waste materials); in the case of materials made with renewable resources, it should be considered that the durability of the components must be calibrated on the basis of the capacity of renewal by the environment (time and quantity required); in the case of

waste materials, the durability and any reconditioning operations must be calibrated on the basis of the assumed life span for the building and for the other components that make up the construction system;

- the materials/ components should be local, available within a maximum mileage radius of 100 km (local dimension defined by the Ithaca Protocol) in order to optimise the impact of transport; the local dimension must concern: supply from the extraction site to the production plant, from the production plant to the place of construction and from the latter to the end-of-life plant (recycling /incineration /controlled discharge); the

- entire life cycle of the materials/ components should therefore be carried out on a local dimension;
- the production and disposal phases of the materials/ components should have a low/ zero environmental impact; this is generally achieved by simplifying and limiting the number of production/ disposal phases and balancing the necessary energy expenditure with clean energy production plant systems;
2. the assembly of the construction system must be controlled:
- through the use of dry systems, whose reversibility of the parts allows each material/ component to follow independent life cycles according to its durability and relative residual and potential performance;
  - through the use of wet systems, in which during disposal a homogeneous product

group is obtained (even if not intact), whose characteristics allow its reuse without any reduction in performance or direct release into the environment.

The analysis of a construction system makes it possible to identify different levels of sustainability depending on the degree of compliance with the conditions indicated, especially with the aim of not affecting the sustainability of the redevelopment of the building as such (Forlani, 2016).

Think, for example, of a redevelopment carried out using a dry construction system with pre-assembled

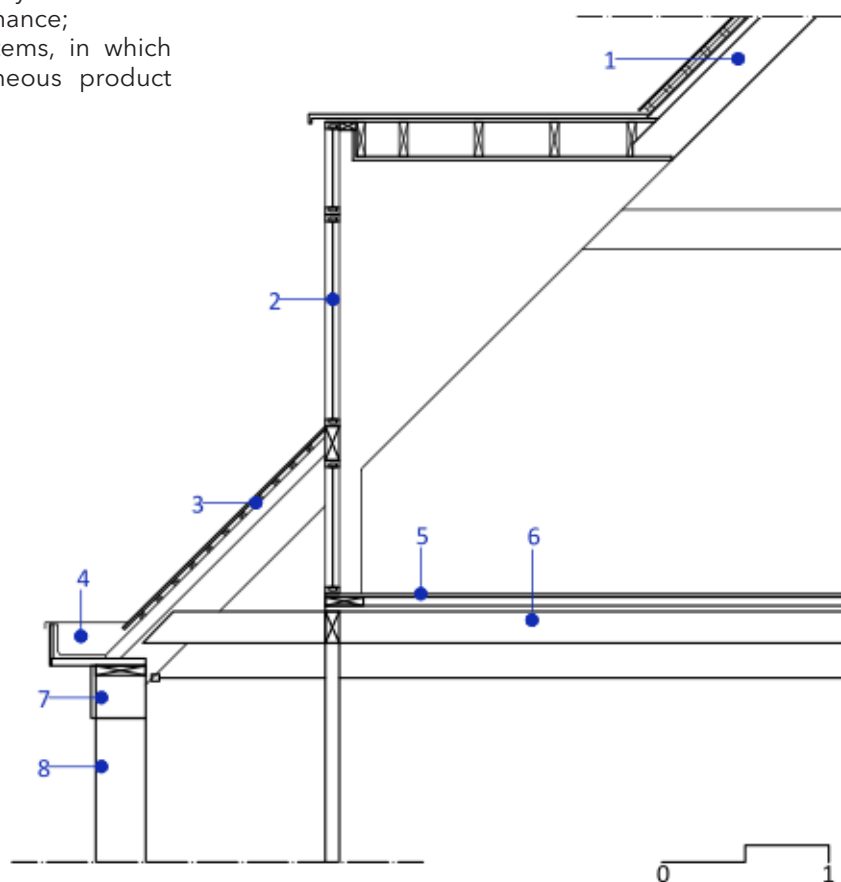

**Figure 3.**  
Construction detail  
House Rot Ellen Berg, Vylder Vinck Taller,  
Oudenaarde, Belgium, 2011  
1- wooden beam, 2- window, 3- roof tiles,  
4- rainwater harvesting, 5- formworks,  
6- wooden beam, 7- reinforced concrete kerb,  
8- existing wall.

plasterboard sandwich panels insulated with synthetic material. The sustainability of the redevelopment operation (due to the protection of the territory and the increased life cycle of the materials that are already installed in the building before its redevelopment) is compromised by the choice of a construction system that, although reversible, consists of components that have a significant environmental impact.

Similarly, the redevelopment of buildings that use construction systems consisting of sustainable materials/ components, but whose disposal involves fragmented product groups or lack of integrity of the components, does not permit a high degree of sustainability of the intervention. For example, the construction systems used in the Earthship designed by M. Reynolds, whose factory elements were made of local materials integrated with waste materials (therefore meeting the first condition listed above), but which were not reversible during decommissioning, produced an undifferentiated product group such as mixed glass, aluminium, rubber, earth, etc.. (therefore, they did not respect the second condition stated above).

By generalising in a dry construction system, a high degree of sustainability can only be achieved if sustainable materials/components are used in the construction phase and a wet construction system can only achieve a high degree of sustainability if it produces homogeneous product groups during disposal without reducing the performance level that can be reused or reused in the environment. Therefore, the sustainability of drywall systems is decided mainly in the construction phase and that of wet wall systems in the decommissioning phase.

### 3. BEST PRACTICES

At international level, it is possible to identify innovative construction systems with a high level of sustainability, since on the one hand they are made of local, renewable or waste materials with a limited impact on production and decommissioning and on the other hand they have assembly characteristics that allow new life cycles or the re-introduction into the environment without environmental impacts.

Among dry innovative systems, the closures (horizontal and vertical) made with reused components from the construction site, such as pipes and joints, multicom systems, bridgeboards, formworks for concrete castings, etc. have an high degree of sustainability. These are construction systems that, already starting with a temporary vocation, intended for the construction of scaffolding on site, have by their very nature, the characteristics of reversibility, flexibility,

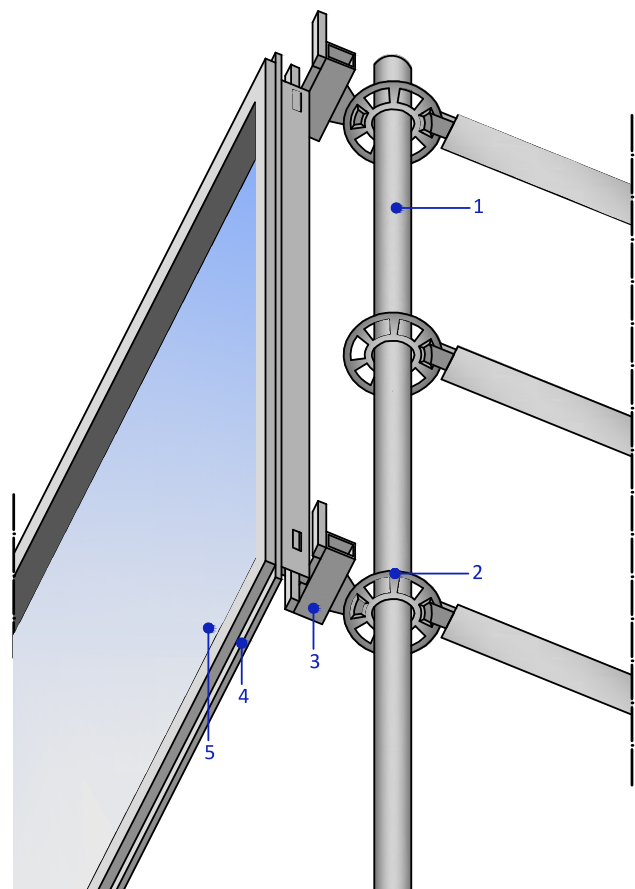

**Figure 4.**

*Construction detail*

*Shaustelle, J. Mayer H., Munich, Germany, 2013*

*1- multicom system, 2- connection ring, 3- plug-in connector, 4- metal frame, 5- semi-matt closure.*

speed and ease of construction. The load-bearing structure made of modular steel elements (pipes and joints, multi-component, etc.) can be integrated with horizontal and vertical closing elements also consisting of components borrowed from the site (bridgeboards, formwork, PVC sheets, pallets, etc..) or with materials/ components from other areas. These are local materials, in fact they are used occasionally on the construction sites and that, therefore, are configured as resources available during periods of inactivity. Due to their construction characteristics, they are reversible and, at the end of their use, they can be easily disassembled and used for other life cycles.

For example, in the House Rot Ellen Berg project, carried out in 2011 in Oudenaarde (Belgium) by Vyllder Vinck Taller a Flemish masonry building has been redeveloped using scaffolding, props, formwork to flexibly configure the interior space; a greenhouse inside the building creates a double casing, helping to provide thermal comfort in winter, and in summer

its open conformation increases the liveable surface area and favours ventilation (Fig.3).

There are also numerous examples in the international field of the use of such systems for the construction of temporary buildings like the Pavillon Humanidade by C. Juacada and B. Lessa built in Rio de Janeiro in 2012, Wendy built in the same year in New York and designed by HWKN, Shaustelle designed by J. Mayer and built in Munich in 2013 (Fig.4) and the Infopoint built in 2016 in Barcelona designed by Peris and Toral Arquitectes.

These systems can therefore be used in the redevelopment of buildings to design a flexible internal distribution according to the needs of users or the creation of new spaces.

Among the wet innovative systems, the closures made with components of hemp wood and lime stand out for their high degree of environmental sustainability (Cavallaro, 2015). The sativa hemp (used in construction) is in fact a weed plant, easy to adapt to the microclimate that can be grown without the use

**Figure 5.**

*Non-structural vertical closure made with all components based on hemp and natural hydraulic lime NHL5.*

*From the inside to the outside: lime and hemp finishing plaster (0,5 cm), lime and hemp brick and mortar (30 cm), lime and hemp plaster (2 cm), lime and hemp finishing plaster (0,5 cm)-*

*Transmittance equal to 0,238 W/m<sup>2</sup>K*

*Periodic thermal transmittance equal to 0,012 W/m<sup>2</sup>K*

*Thermal phase shift equal to 19,17 hours*

*Attenuation factor equal to 0,05*

*(source: Edilcanapa).*





of pesticides, has a very low water consumption and has a fertilizing effect on the soil (Pennacchio, Zullino, 2018).

The external fibrous part has a high tensile strength and the internal woody part (the canopy) has excellent insulating properties. Lime, on the other hand, acts as a binder. The realization of materials/ components in hemp and lime wood is therefore characterized by the use of natural materials and by an elementary production process with a low environmental impact that includes: separation of the fibre from the hemp, cleaning of the hemp from dust, chipping and selection in different sizes, the addition of lime according to the established proportion, the addition of water and any additives and mixture to form a homogeneous compound, and natural drying. In case of realization of preformed components, the forming is required before natural drying (Bevan, Wolley, 2008).

Regarding the production process, the different proportions of hemp, lime and water, the different dimensions of the canopy and fibre and the presence of additives give rise to different materials.

Among the manufacturing companies, Edilcanapa (Italian company) has designed a non-structural vertical closure made entirely of components in hemp and lime, a feature that allows the reuse of waste material (Fig.5). In fact, during construction, since this is a construction system carried out on site, in the case of cutting some components to size, or for the creation of ducts for the passage of implants, the waste materials, properly gathered on sheets to avoid contamination with other substances, can be remixed and reused. Further, the demolished vertical closure while not preserving its integrity provides a homogeneous product that can be reused for the creation of new materials/components or being returned to the environment by becoming a potential soil fertiliser<sup>3</sup>.

This vertical closure can be used in the rehabilitation of buildings to redefine the spaces in the building (consider, for example, the reconstruction of a collapsed floor or the construction of controlled additional elements) and to improve energy efficiency (Benfratello et al., 2013) (consider, for example, an intervention to use an existing wall for support with the aim of increasing thermal insulation as shown in the figure 6). In fact, compared to other commonly used

insulation materials (e.g. expanded polyethylene, rock wool, wood fibre, sheep wool, etc.), the hemp wood and lime insulation combines good thermal performance both in winter and in summer.

The choice of the building system must be consistent in all its parts (horizontal closure, vertical closure, stairs etc.) both from a strictly technological and from sustainability points of view (Gangemi, 1985). If, for example, a vertical closure with a high degree of environmental sustainability is used (such as closure in



**Figure 6.**  
*Re-qualification of a vertical closure by affixing a masonry of bricks and mortar in hemp and lime with the aim of increasing the thermal performance of the wall (source: Edilcanapa).*

scaffolding or closure in lime and hemp), if necessary, we should use compatible systems in the interventions on horizontal closures or the load-bearing structure, i.e. systems that are compatible from a construction point of view and, at the same time, have the same degree of sustainability.

#### **4. CONCLUSIONS**

Environmental sustainability of interventions depend on many factors, which affect the entire life cycle of the building and in particular the impact that the intervention has on the environment, not only in the present but also and especially in the future.

In order to safeguard the intrinsic sustainability of the rehabilitation of a building and to increase the degree of sustainability of the intervention, it is necessary to control both the management phase, through the achievement of energy efficiency, and both construction and demolition phases through the choice of the construction system. The latter should, on the one hand, contain materials/components that have low/ no environmental impact and, on the other hand, should be made using construction techniques that ensure the components remain intact and can be reused or that homogeneous product groups are obtained without lowering performance thereby allowing re-cycling or re-introduction into the environment.

In controlling the sustainability of the intervention it is also necessary to make consistent choices between the various parts of the construction system and between these and the existing building.

A sustainable intervention is therefore recognizable as capable of triggering virtuous mechanisms on the territory such as to activate new local economies.

#### **NOTES**

1. Rapporto 2019 "Consumo di suolo, dinamiche territoriali e servizi ecosistemici" - Sistema Nazionale per la Protezione dell'Ambiente (SNPA)  
<https://www.snambiente.it/2019/09/17/consumo-di-suolo-dinamiche-territoriali-e-servizi-ecosistemici-edizione-2019/>  
[https://webgis.arpa.piemonte.it/secure\\_apps/consumo\\_suolo/?entry=6](https://webgis.arpa.piemonte.it/secure_apps/consumo_suolo/?entry=6)
2. ISTAT data - Analysing the state of conservation of residential buildings, alarming data are highlighted. The 20.3% of the houses are in a poor state of conservation and the 2.3% in a bad state of conservation. With reference to buildings constructed before 1921, the 27% were in a poor state and the 3.4% in a poor state.
3. The slaked lime in agriculture can in fact be used with the aim of increasing the PH of the soil, to increase the yield of production.

## ACKNOWLEDGMENTS

The author thanks Edilcanapa (Mosciano Sant'Angelo, Italy) for the collaboration.

## REFERENCES

- Andrew Scott, M. I. T. (2003) *Dimensions of sustainability*. Taylor & Francis
- Bauman, Z., (1992) *La decadenza degli intellettuali. Da legislatori a interpreti*, Bollati Boringhieri, Torino
- Bauman, Z.. (2013) *Liquid modernity*. John Wiley & Sons
- Benfratello, S., et al. (2013) Thermal and structural properties of a hemp-lime biocomposite. *Construction and building materials*, 48: 745-754.
- Bevan, R; Woolley, T., (2008) *Hemp lime construction. A guide to building with hemp lime composites*, Bracknell
- Bosia, D., (2011) *Energetic behaviour and Renewable Energy in traditional rural architecture*. UNDP Croatia. United Nations Development Program
- Bribián, I.; Usón, A.; Scarpellini, S., (2009) Life cycle assessment in buildings: State-of-the-art and simplified LCA methodology as a complement for building certification. *Building and Environment*, 44.12: 2510-2520
- Butera, F., (2007) *Dalla caverna alla casa ecologica*, Edizioni Ambiente, Milano
- Cabeza, L. et al. (2014) Life cycle assessment (LCA) and life cycle energy analysis (LCEA) of buildings and the building sector: A review. *Renewable and sustainable energy reviews*, 29: 394-416.
- Castanheira, G.; Bragança, L., (2014) The evolution of the sustainability assessment tool: From buildings to the built environment. *The Scientific World Journal*
- Cavallaro, G. (2015) *La coltivazione della canapa in Italia problematiche e prospettive*.
- Chenut, D., (1968) *Ipotesi per un habitat contemporaneo*. Il saggaiatore
- Davoli, P, et al. (2010) *Il recupero energetico ambientale del costruito*.
- De Berardinis, P, (2007) *Costruire sostenibile. L'industria delle Costruzioni*, 393: 4-21.
- Forlani, M. C., (2016) *L'edilizia sostenibile*, in Forlani M. C., Vallicelli A., *Design e innovazione tecnologica, modelli d'innovazione per l'impresa e l'ambiente*, Gangemi Editore, Roma
- Francese, D., (2000) *Architettura bioclimatica: risparmio energetico e qualità della vita nelle costruzioni*.
- Francese, D., (2002) *Il benessere negli interventi di recupero edilizio*. CUSL nuova vita.
- Gangemi, V. (1985) *Architettura e tecnologia appropriata*. Franco Angeli, Milano.
- Giardiello, P., (2009) *Smallness: abitare al minimo*. CLEAN.
- Greco, A.; Quagliarini, E. (ed.). (2007) *L'involucro edilizio: una progettazione complessa* (Artec 2007). Con CD-ROM. Alinea Editrice.
- Gulli, R., (2018) *Recupero sostenibile del patrimonio costruito in ambito sismico*. Edicom.
- Hegger, M., et al. (2012) *Energy manual: sustainable architecture*. Walter de Gruyter.
- Kellenberger, D.; Althaus, H., (2009) Relevance of simplifications in LCA of building components. *Building and Environment*, 44.4: 818-825.
- Imperadori M., (2001) *Costruire sul costruito: tecnologie leggere nel recupero edilizio*. Carocci editore.
- Lavagna M., (2008) *Life Cycle Assessment in edilizia. Progettare e costruire in una prospettiva di sostenibilità ambientale*, Hoepli, Milano.
- Magnaghi A., (2010) *Progetto locale. Verso la coscienza di luogo*, Bollati Boringhieri, Torino.
- Malighetti, L.E., (2011) *Recupero Edilizio. Strategie per il riuso*. Il Sole 24 ORE.
- Mora, E., (2007) *Life cycle, sustainability and the transcendent quality of building materials*. *Building and Environment*, 42.3: 1329-1334.
- Orbasli, A; Barch, D., (2009) *Re-using existing buildings towards sustainable regeneration*. School of Architecture: place and Culture Identity Group Working Paper.
- Pennacchio R; Zullino, M. G., (2018) *Costruire in canapa e calce: Progetto "Case di Luce"*.
- Rita, G.; Bonomi, A. (1998) *Manifesto per lo Sviluppo Locale-Dall'azione di comunità ai Patti territoriali*. Torino: Bollati Boringhieri. SNPA- Sistema Nazionale per la Protezione dell'Ambiente Rapporto 2019 - "Consumo di suolo, dinamiche territoriali e servizi ecosistemici"  
<https://architectendvvt.com/> - Accessed April 5, 2019

<https://commons.wikimedia.org/w/index.php?curid=59350894> -  
Accessed September, 15, 2019

<https://www.edilcanapasrl.it/> - Accessed March 7, 2019

<https://www.istat.it/> - Accessed January 23, 2019

[https://www.itaca.org/valutazione\\_sostenibilita.asp](https://www.itaca.org/valutazione_sostenibilita.asp) - Accessed June  
4, 2019

<http://www.jmayerh.de/> - Accessed April 7, 2019

<http://www.portale4e.it/> - Accessed August 28, 2019

[https://www.snambiente.it/2019/09/17/consumo-di-suolo-  
dinamiche-territoriali-e-servizi-ecosistemici-edizione-2019/](https://www.snambiente.it/2019/09/17/consumo-di-suolo-dinamiche-territoriali-e-servizi-ecosistemici-edizione-2019/) -  
Accessed August 17, 2019

<https://www.unicalce.it/> - Accessed September 9, 2019

[https://webgis.arpa.piemonte.it/secure\\_apps/consumo\\_  
suolo/?entry=6](https://webgis.arpa.piemonte.it/secure_apps/consumo_suolo/?entry=6) - Accessed September 11, 2019