

Diseño de mobiliario

TFG MOVILIDAD

Jaume Luna Alapont

2015/2016

ÍNDICE

0. Introducción	3
1. <i>Comfort</i>	4
a. Briefing <i>Comfort</i>	5
b. Proyecto <i>Comfort</i>	8
2. <i>Contract Lighting</i>	21
a. Briefing <i>Contract Lighting</i>	22
b. Proyecto <i>Contract Lighting</i>	26
3. <i>Rapid Product Development</i>	40
a. Briefing Proyecto	41
b. Proyecto	45
c. Briefing Trabajo de investigación	64
d. Trabajo de investigación	66
4. <i>Design Analysis</i>	89
a. Ejercicios realizados	90
b. Proyecto	108

0. INTRODUCCIÓN

Este Trabajo de Fin de Grado es el resultado de una movilidad Erasmus en Dublin Institute of Technology, y está formado por cuatro de las seis asignaturas realizadas en el segundo semestre del curso 2015/2016.

Siguiendo con la especialización en diseño para el hábitat, dos de las asignaturas escogidas para el proyecto son de diseño de muebles y las otras dos asignaturas tratan métodos de prototipado rápido y análisis físicos mediante softwares informáticos CAD.

Dichas asignaturas son:

Comfort, diseño de un sofá.

Contract Lighting, diseño de un juego de lámparas.

Rapid Product Development, métodos de prototipado rápido.

Design análisis, análisis físicos y de resistencia.

A lo largo de este documento se mostrarán todos los contenidos aprendidos y proyectos realizados en dichas asignaturas, cada una precedida de una breve introducción.

1. COMFORT

En esta asignatura se realiza el proceso completo de diseño de un sofá, basándose en el concepto de comodidad como base para crear un producto innovador.

Durante el proceso la fase creativa toma importancia para asegurar un producto final original, de calidad y con valor de diseño. En este proceso se pone en común el avance en el proyecto con la clase mediante presentaciones, y de este modo todos aportan sugerencias al producto y al proceso creativo aprendiendo del resto de compañeros en un ambiente que motiva a los estudiantes para mejorar.

También se lleva a cabo el diseño de detalle, dibujos CAD del producto, planos técnicos y maqueta, todo ello recogido en un portfolio.

1.a BRIEFING COMFORT

**DUBLIN INSTITUTE OF TECHNOLOGY
DUBLIN SCHOOL OF CREATIVE ARTS
BA (DESIGN) INTERIOR+FURNITURE
YEAR 3**

Subject Title	Furniture Design
Module Title	Aspects of Comfort Upholstery
Module Code	FURN3003
Period	Weeks 23-37
Evaluation Method	Continuous Assessment

AIMS *To develop an understanding of the physiological and psychological considerations that influence comfort in furniture*

SYLLABUS **Aspects of traditional and modern upholstery**
Psychological / Physical aspects of seating
Sculptural and organic form
Measurement of comfort
Flexible foams and fabrics
Standards, regulations etc.
Ergonomic considerations

PROJECT TITLE **Aspects of comfort**

INTRODUCTION *GROUP OPTION A – This option aims to introduce a collaborative aspect to the development of new products. Week 1 of the project requires the group to conduct research into the field of upholstery/comfort. The research should cover the listed syllabus and the students are required to distribute the workload of the research and present a combined document, which will act as a guide to the design of the products. Each member of the group must have a complete copy of the research document by February 16th, for discussion. One additional copy must be made available to the course tutor by that date.*

INDIVIDUAL OPTION B – To research the field of upholstery/comfort. The research should cover the listed syllabus and the student is required to present a document, which will act as a guide to the design of the products. The research phase should be completed by February 16th.

BRIEF *You are invited to design a collection of matching innovative 'upholstered' seating for a European furniture company. The concept should place a heavy emphasis on comfort + form. The company intends to launch the new collection in Milan at the international furniture fair, Spring 2017. The company is willing to invest in new technology, but are anxious to exploit their existing traditional upholstery skills and techniques. Initial market place investigations have suggested that the most appropriate opportunities will give consideration to flexibility, interchange ability and comfort within the domestic environment. It is important to examine the latest trends in the marketplace and give due consideration to these in the development of concepts.*

REQUIREMENTS *Research- all aspects of comfort incl. a personal philosophy and live research.
Substantial Conceptual developments through 3d sketch models +sample detail mock -ups.
Rendered Presentation Drawings (min 6 Sheets) demonstrating salient aspects of your designs.
Set of full size/scale dimensioned working drawings
Finished Scale Models – Scale 1:5 well made
All scale drawings and presentation to be mounted in A3 Book form*

STARTING DATE 26th January 2016

SUBMISSIONS

Research Submiss. 16th February 2016
Concept Submiss. 15th March 2016
Synth/Res.Submiss 12th April 2016
Presentation 26th April 2016
Final Submission To be agreed

Dates are subject to change

Late Penalties – 5% of possible credits will be deducted per day up to one full week from submission time -beyond which a failure may result. It will be the students' responsibility to inform a member of staff and have their submission recorded.

**ASSESSMENT
CRITERIA**

The project will be assessed under each of the following criteria:

Research
Initial Broad Conceptualisation of Ideas
Creativity + Innovation
Concept Development
Communications
Presentation

Texts:

Recommended:

Brown, Amanda, 2013, Spruce: Upholstery and Design /, Pownal, Vermont : Storey
Crowley, John E, 2001, The invention of comfort : sensibilities & design in early modern Britain & early America, Johns Hopkins University Press
Dobson, Cherry, 2009, The upholstery bible : complete step-by-step techniques for professional results, David & Charles, Cincinnati, Ohio
Fehlbaum, Rolf & Demetrios, Eames, 2008, The furniture of Charles and Ray Eames, Weil am Rhein : Vitra Design Museum.
Fiell, Charlotte & Peter, 2012, Chairs : 1,000 masterpieces of modern design, 1800 to present, London : Goodman Fiell,
Grandjean, Etienne, 1973, Ergonomics of the home / [translated from the German by Harold Oldroyd ; edited by P.R. Davis] London : Taylor and Francis
James, David, 2009, Beginners' upholstery techniques /. Lewes [England], Guild of Master Craftsman Publications.
Jordan, Patrick W, 2002, Designing Pleasurable Products –An introduction to the new Human, Taylor + Francis, London + NY.
Norbury, Betty, 1999, Furniture for the 21st century, Hertford : Stobart Davies.
Perrault, Dominique, Lauriot-Prévost, Gaëlle, 1997, Furniture and Fabrics, Birkhäuser Verlag: Basel-Boston.
Vink, Peter, 2005, Comfort and design: principles and good practice, Boca Raton: CRC Press
von Vegesack, Alexander, and Remmele, Mathias, 2003, Marcel Breuer : design and architecture / Vitra Design Museum, Weil am Rhein : Vitra Design Stiftung.

Tutor:

Robert Tully

1.b PROYECTO COMFORT

COLOM



COMFORT MARKET STUDIO

Seem comfortable

Doesn't seem comfortable

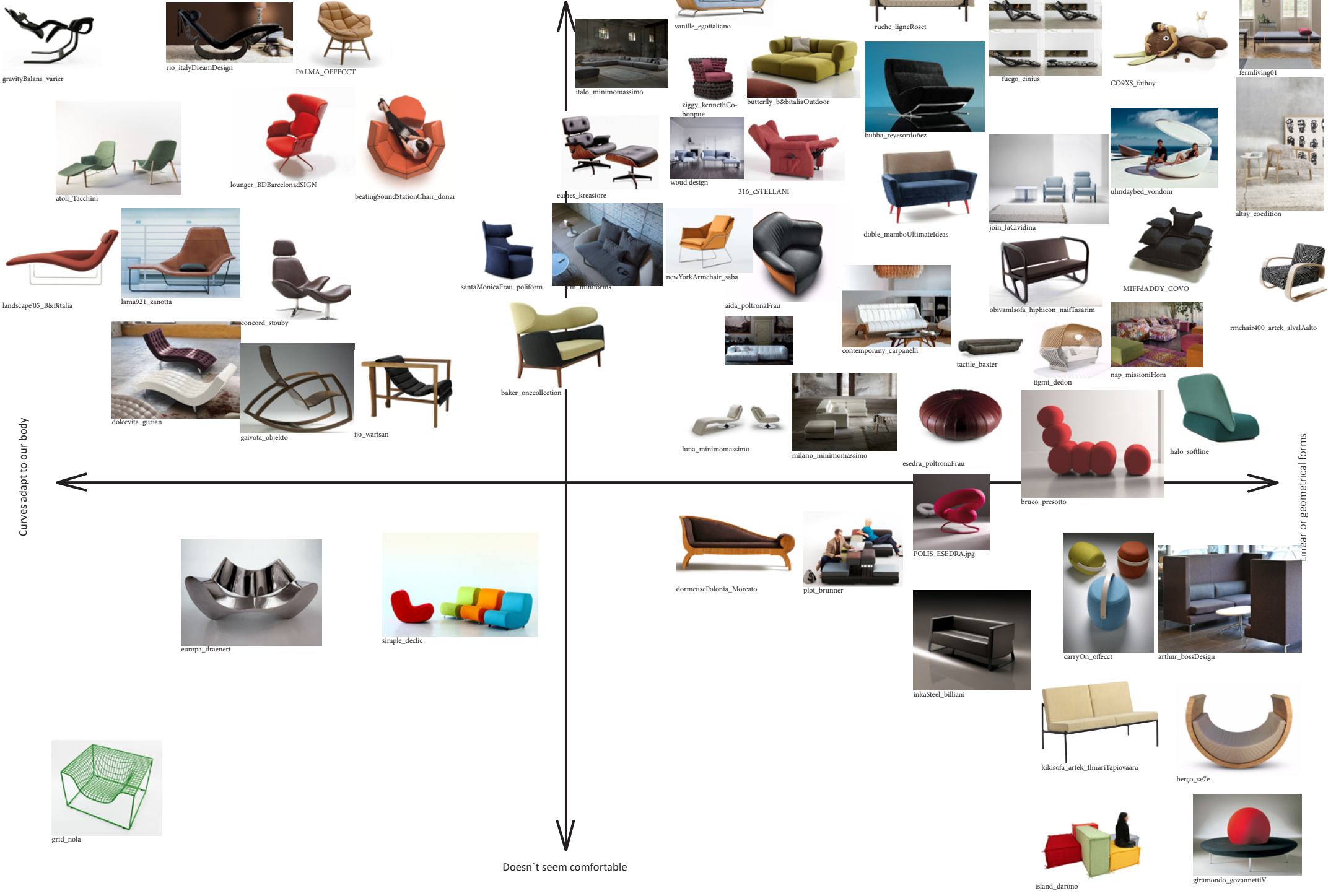

gravityBalans_varier

rio_italyDreamDesign

PALMA_OFFECCT

vanille_egoitaliano

ruche_ligneRoset

fuego_cinius

CO9XS_fatboy

fermliving01

atoll_Tacchini

lounger_BDBarcelonadSIGN

beatingSoundStationChair_donar

caeres_kreatore

woud design

316_cSTELLANI

bubba_reyesordonez

join_laCividina

ulmdaybed_vondom

altay_coedition

landscape05_B&Bitalia

lama921_zanotta

concord_stouby

santaMonicaFrau_poliiform

em_miniforms

newYorkArmchair_saba

aida_poltronaFrau

doble_mamboUltimateIdeas

obivamsofa_highicon_naifIasarim

MIFFdADDY_COVO

rmchair400_artek_avalAalto

dolcevit_gurian

gaivota_objekto

ijo_warisan

baker_onecollection

luna_minimomassimo

milano_minimomassimo

esedra_poltronaFrau

bruco_presotto

halo_softline

europa_draenert

simple_declic

dormeusePolonia_Moreato

plot_brunner

POLIS_ESEDRA.jpg

carryOn_offecct

arthur_bossDesign

grid_nola

inkaSteel_billiani

kikisofa_artek_IlmariTapiovaara

berço_se7e

island_darono

giramondo_govannettiV

COMFORT IDEAS

- Softness/efficiency from the comfortable air trainer or shoes that adjust to the shoe's shape

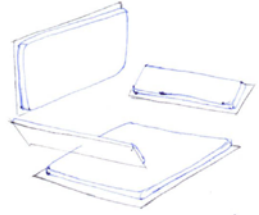

silicone or dense pillows that allows comfortable support out of planes with no curve

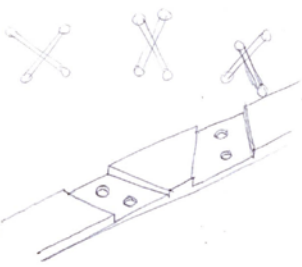
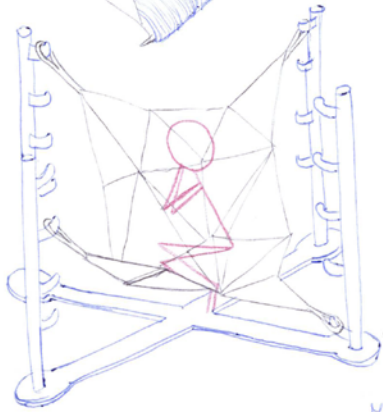

Multifunctional product because of its permeability and adjustability. The base (in blue) changes to diverse positions that allow the user to put the sitting part in back in various positions. These sitting part will be made of plane joints in a circle. This allows joints to move and rest.

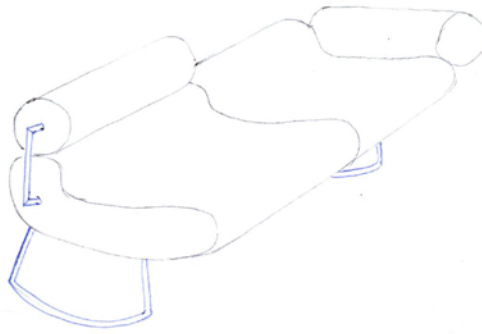
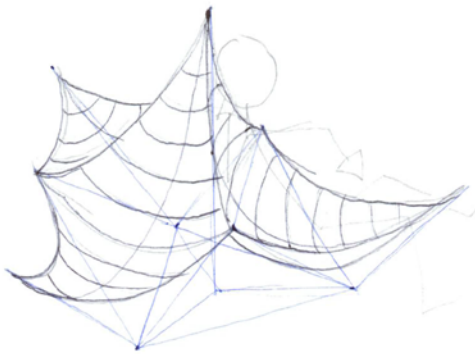
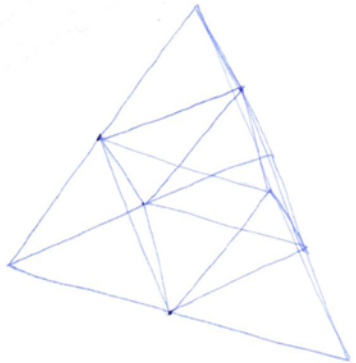
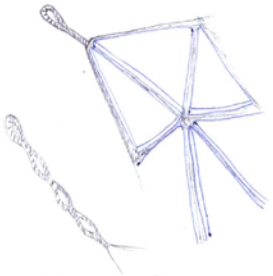

Soft with little balance that creates a good feeling

Multiple positions of the cylindrical pillow for sitting position or armchair/bed support or sitting position with less built room

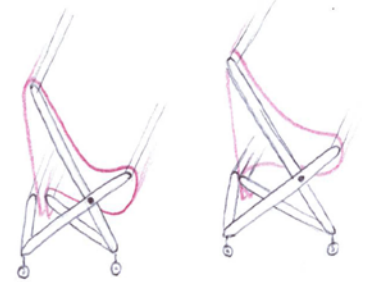
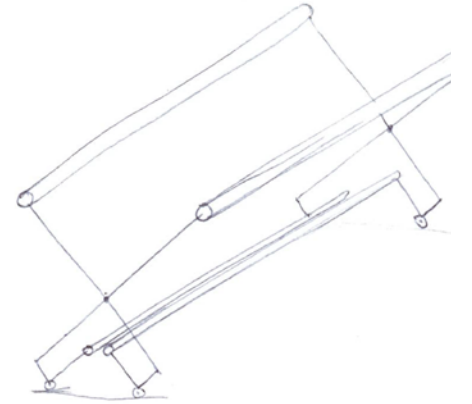
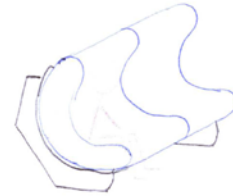
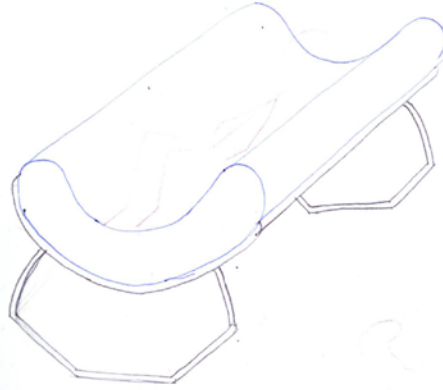

Just two backs are enough to delete the lateral supports, so if people wants to lay into a side they can lay to the one already prepared or change position.

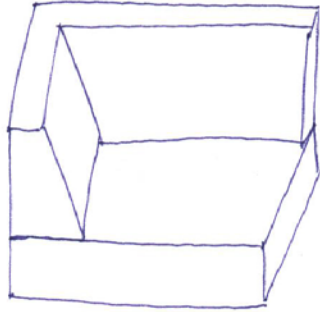

• Rounded surfaces seem more comfort and allow an easy change of position.

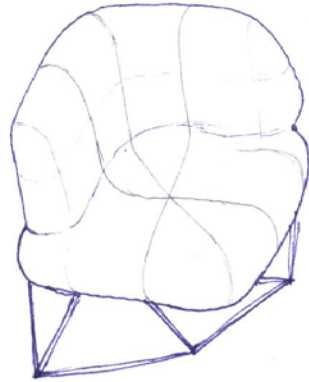

The legs indicate the two ways of sitting that this chair has.



relax



action

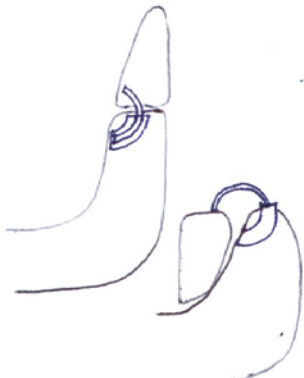
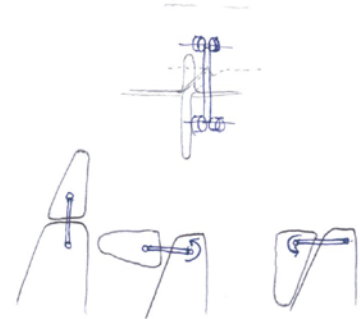

The head support and back support surfaces need to coincide

↑ Angle of the rest must be a little inclinate

Impossible
Stable
Plane surface to hold
cups, bottles, books, papers
or even write on it.

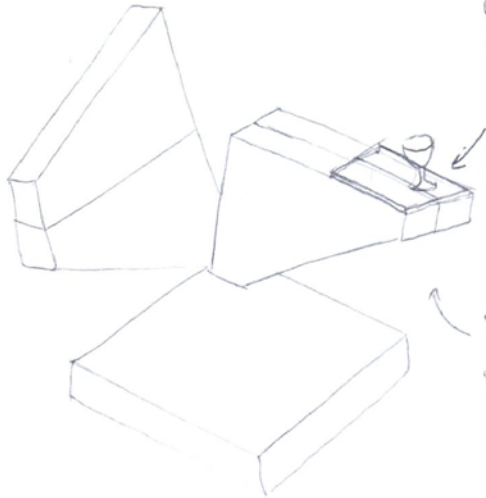

Space to put the legs in
Will work if the backrest
were in an angle smaller
than 95° 

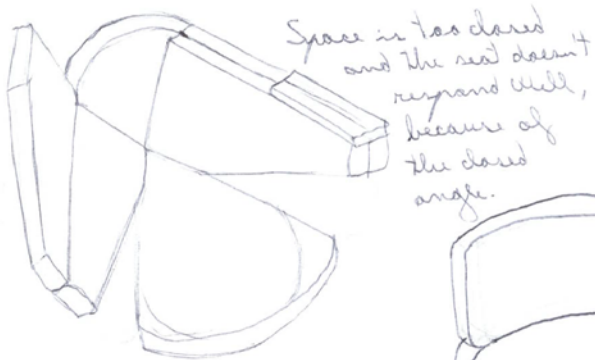

Space is too closed
and the seat doesn't
retract well,
because of
the closed
angle.

In order to approach
the chair to a table
make the user sit in
the center.
This breaks the
curves and
the auxiliary table
are.



Even opening the angle of the
two backrests it's impossible
to make this sofa adaptable
with tables or standing tables

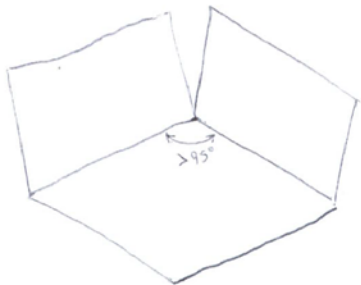

So it'll be logical to use this sofa as a resting
one, and small tables. This determines the height.

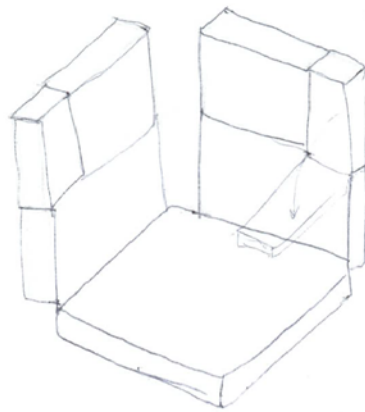

To the psychological dimension of the seatrest.
in a rest chair is recommended to be between
91-94 cm and in work chair 39-40.
Silla Barcelona = 50
So, sofas are more deep.

Splitting the upper backrest in
two could set up a front working
table. But the bed length would have to be
very big and the place for the person
too!



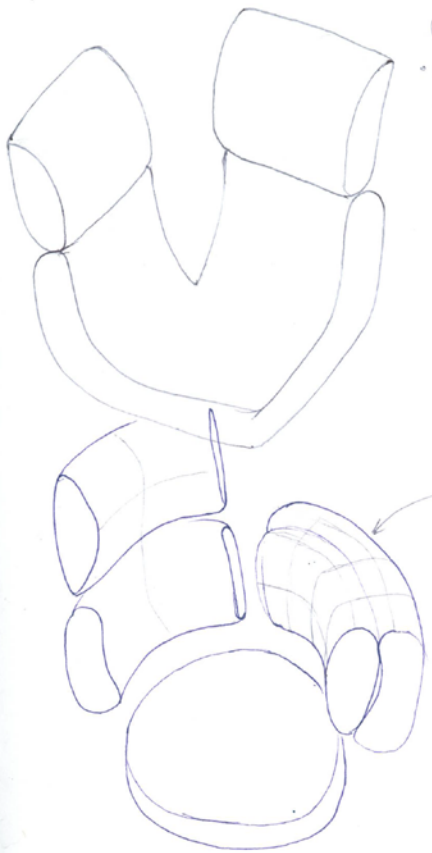
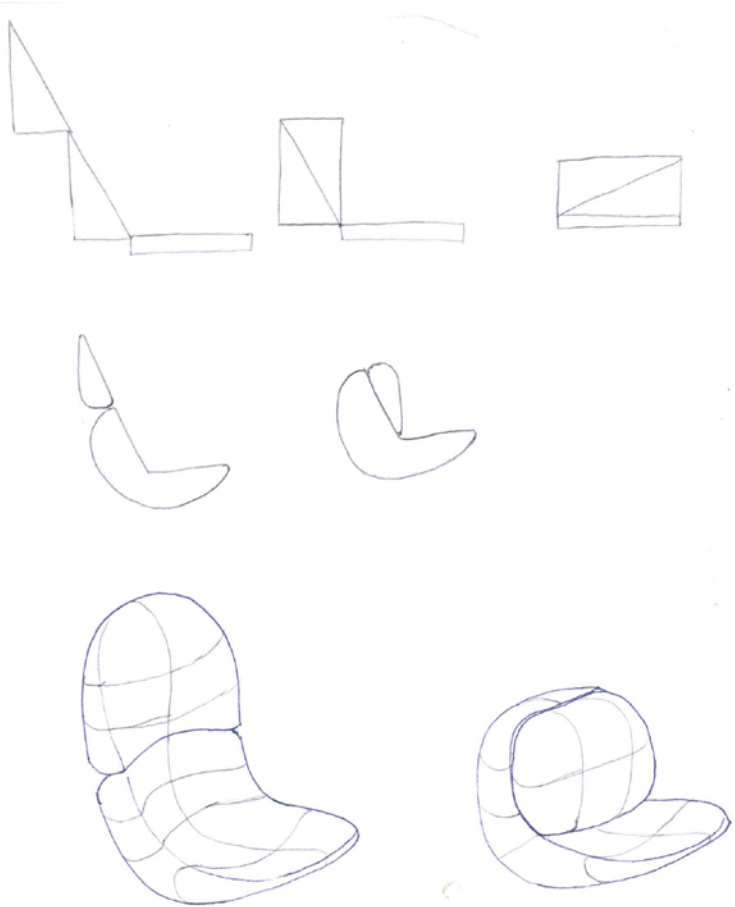

Original idea:
 • Sofa where two sitting directions are possible.
 Using the backrest in disuse as an armrest or surface to incline for near rest.
 • Double functionality (resting and working position) gained by adding a foldable, 2 position headrest which allows

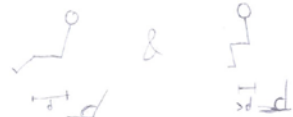

Labels become a table for bearing a book or a glass

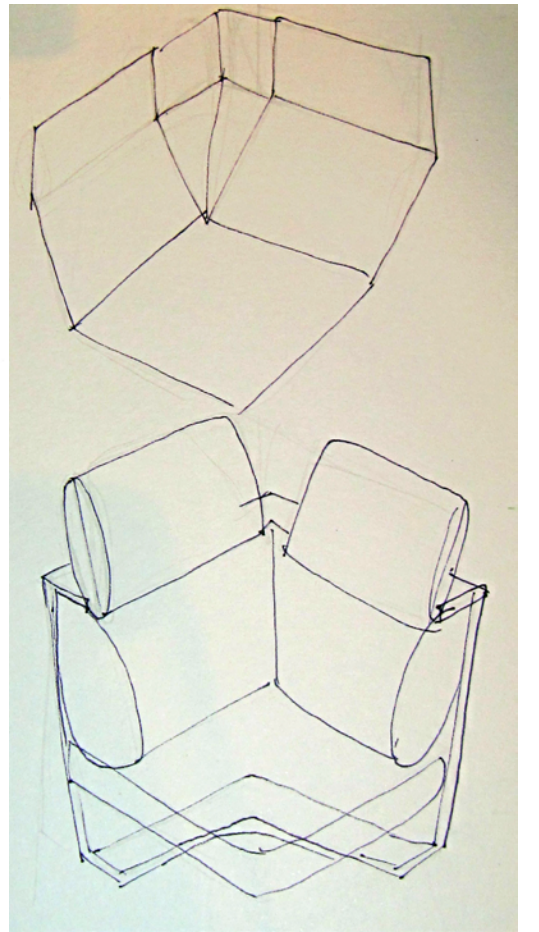
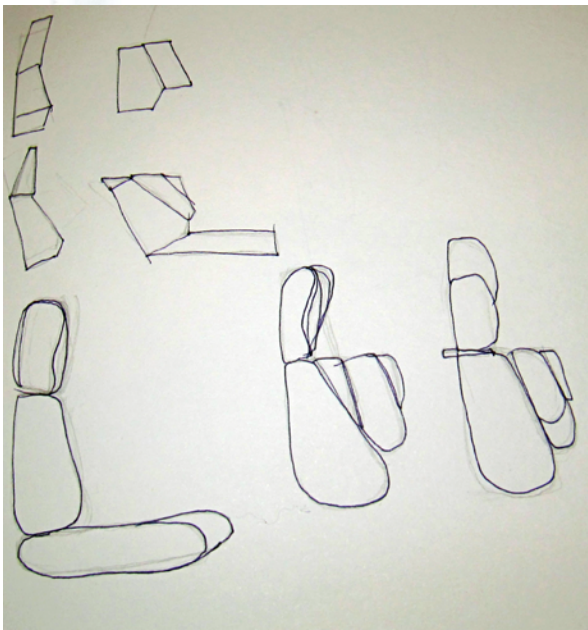

HUMAN DIMENSION & INTERIOR SPACE

A SOURCE BOOK OF
DESIGN REFERENCE STANDARDS



BY JULIUS PANERO, AIA, ASID
AND MARTIN ZELNIK, AIA, ASID

THIRD EDITION

BODYSPACE

**ANTHROPOMETRY,
ERGONOMICS
AND THE
DESIGN OF WORK**

Stephen Pheasant
Christine M. Haslegrave

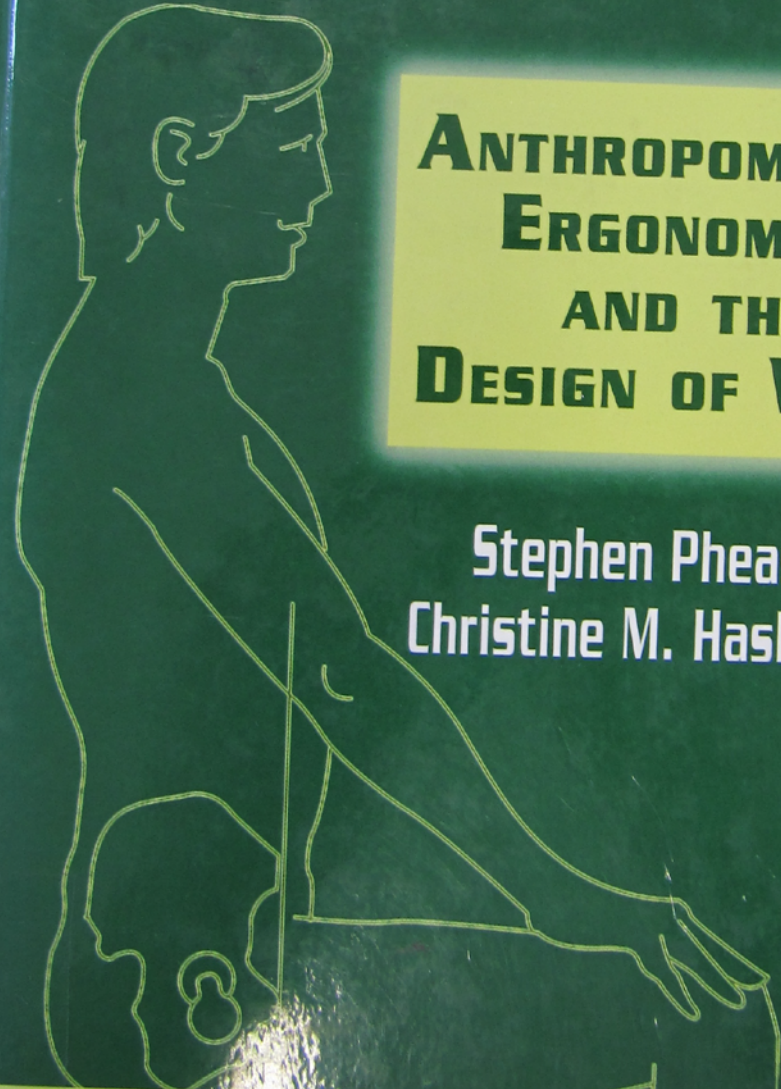

Taylor & Francis
Taylor & Francis Group

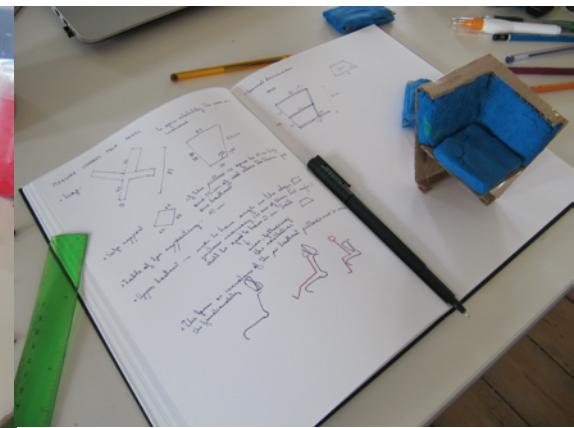
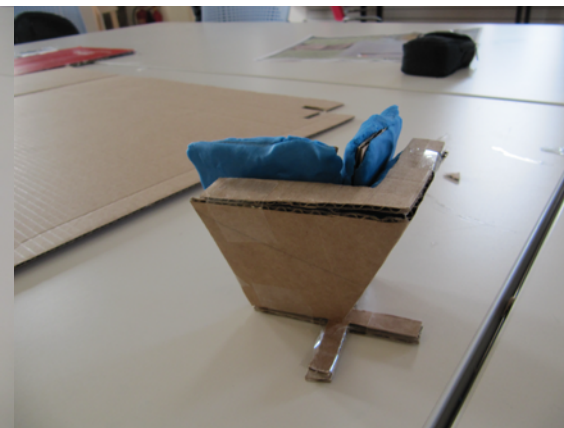
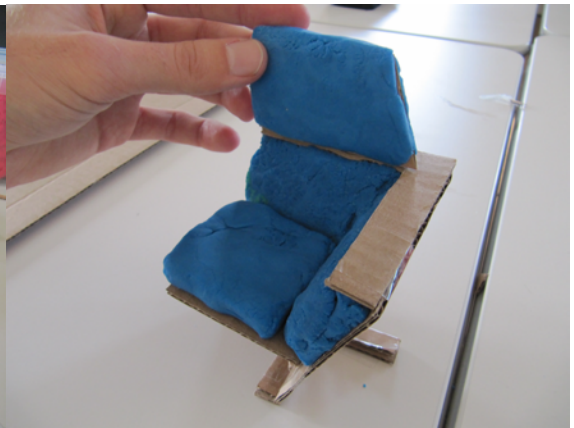
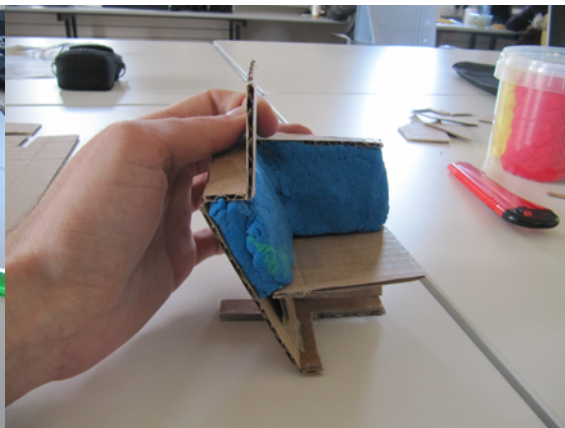
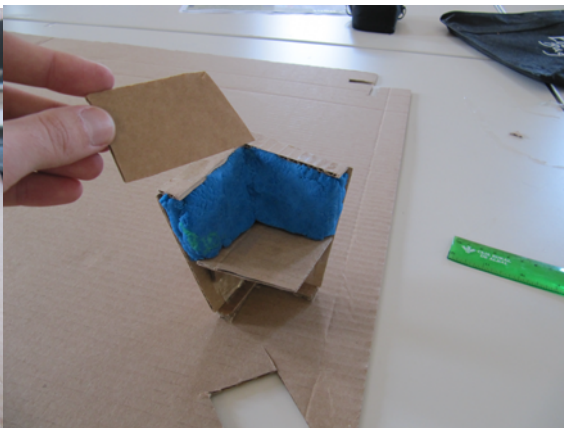
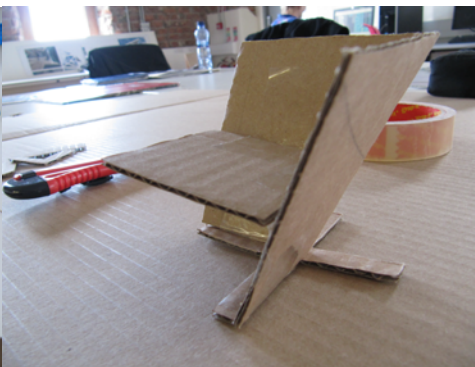
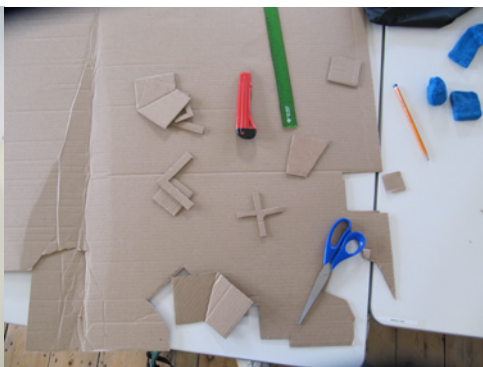



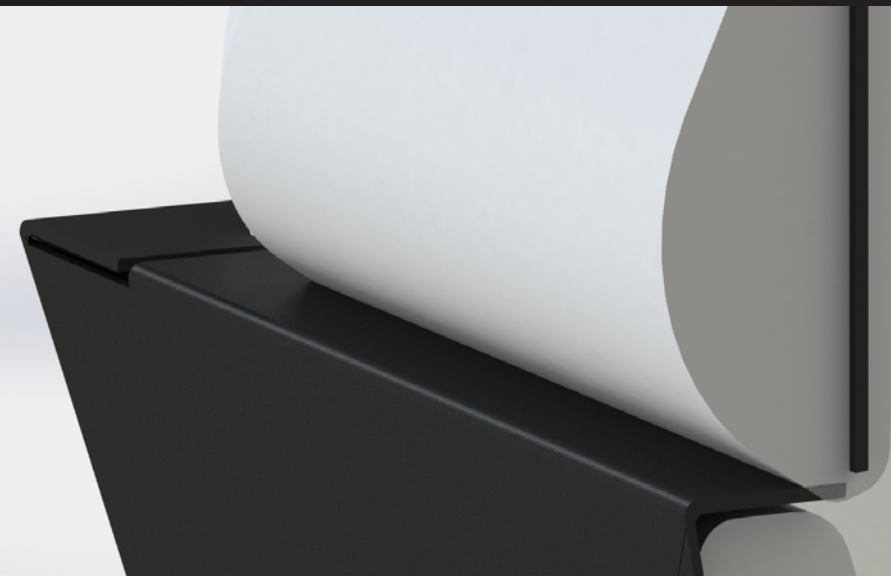
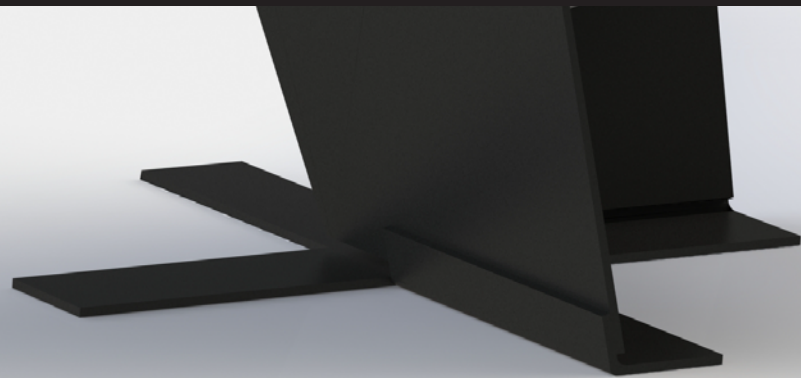
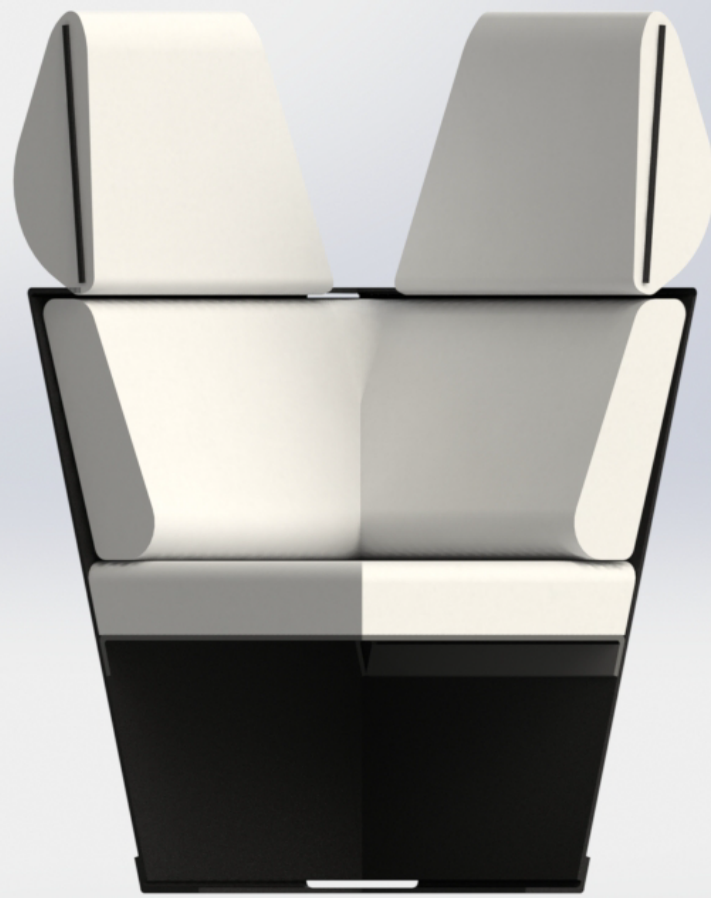

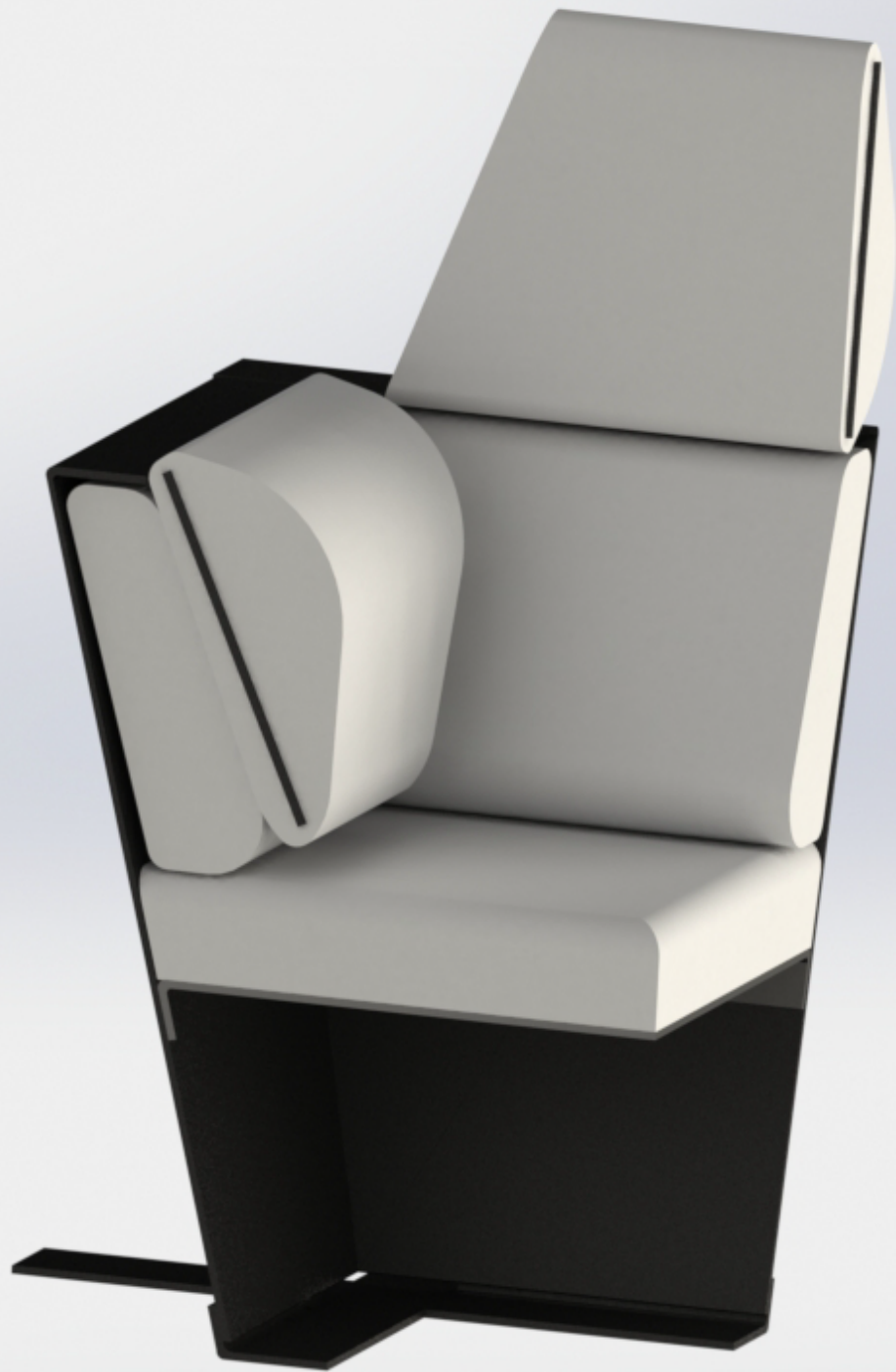



2. CONTRACT LIGHTING

En esta asignatura se realiza el proceso completo de diseño de una lámpara o juego de luminarias.

En este producto se desea transmitir un sentimiento y para ello se realizan estudios fotográficos de luz.

Durante el proceso la fase creativa toma importancia para asegurar un producto final original, de calidad y con valor de diseño.

También se lleva a cabo el diseño de detalle, dibujos CAD del producto, planos técnicos y maqueta.

2.a BRIEFING CONTRACT LIGHTING

**DUBLIN INSTITUTE OF TECHNOLOGY
MOUNTJOY SQUARE
SCHOOL OF ART , DESIGN + PRINTING
BA (DESIGN) INTERIOR + FURNITURE
YEAR 2**

Subject Title	Furniture Design
Module Title	Lighting
Module Code	FURN 2002
Period	Semester 2
Evaluation Method	Continuous Assessment

AIM The aim of this module is to introduce the student to the basic design requirements for retail/contract furniture. To introduce the student to the concept of modular systems in furniture and an understanding of flexibility and interchangeability in the context of commercial design situations. To provide an introduction to modular systems of furniture and to develop the students understanding and application of appropriate materials, components and assemblies

This module also introduces the student to the basic principles of marketing and development in contract furniture with an emphasis on market orientated commercial design solutions.

SYLLABUS Introduction to dual and multi-functional design theories
Introduction to materials, components and assemblies as applied to dynamic structures
Marketing, distribution and client relationships in contract furniture business
Materials, finishes and production specifications relevant to contract furniture
Principles and techniques of design as applied to the development of furniture collections
Statutory requirements relating to the design and production of contract furniture
Study of appropriate systems, mechanisms and demonstration diagrams

PROJECT TITLE **Lighting products**

INTRODUCTION "Lighting design will be more sensational, artistic and progressive....it will embody a new culture and the challenge of the unknown." Shegiru Uchida

"Each light that I design teaches me something about the integration of form and light within a certain context. Ideally these elements should become a whole using the simplest terms." Alec Drummond

"The future will bring us more lamps that display a subtle sense of humour and humanity, warmth and colour." Brian Stewart

BRIEF You are asked to design a collection of innovative lighting products for an international Lighting Company, through exploring the artefacts which provide us with light. The company intends to launch the new collection in Milan at EuroLuce in April 2017. The company is willing to use a broad base of sub-contract manufacturing and so is interested in considering a variety of concepts. The company currently operates within

the contemporary lighting sector with products in both the contract and domestic areas.

You are expected to give consideration to the system aspect of the product that you propose both from a functionality and manufacturability perspective. You are encouraged to use a variety of materials in the execution of this project. However, these materials must be sensitive to the environment and appropriate to the design solution.

The design concepts must be in keeping with the light technology that you choose to use ie. LED, Tungsten, Halogen, Fluorescent, Low Voltage etc.

REQUIREMENTS

Research – Broad base of research on contextual and technical aspects of lighting
 Substantial Conceptual developments through sketch designs
 Rendered Presentation Drawings (min 3)
 Set of full size/scale working drawings
 Scale Model – Working Prototype
 Scale: As appropriate - well made

Text

Required:

Margolin, V. Buchanan, R. The idea of design-A Design issues reader, MIT PRESS 1995.

Recommended:

Bucquoye, Moiek E., 2002, From Bakelite to Composite: Design In New Materials, Oostkamp: Stichting Kunsboek.

Byers, Mel, 1997, 50 Lights Innovations in Design and Materials, Roto Vision, New York

Clarkson, John, 2003, Inclusive Design For Whole Population, Springer: New York

Crone, John, 1980, Anthropometry for Designers, Batsford Educational

Grandjean, E., Eral, 1973, Ergonomics for the Home, Taylor Francis

Karwowski, W, Soares, M. M., & Stanton N. A., 2011, Human factors and ergonomics in consumer product design, Boca Raton, FL: CRC Press

Milton, Alex & Rodgers, Paul , 2013, Research methods for product design, London: Laurence King Publishing

Urban, Glen L.and Hauser, John R. 1993, Design and Marketing of New Products, Prentice-Hall, 1993

Vihma, Susann, 1990, Semantic visions in design: proceedings from the Symposium on Design Research and Semantics, Helsinki, UIAH.

Websites:

www.ikea.com

www.erco.com

www.designboom.com

Documents:

http://www.lighting.philips.com/pwc/li/cn_zh/connect/tools_literature/assets/downloads/basics_of_light.pdf

<http://www.lighting.philips.co.uk/>

DATE OF ISSUE	Friday 29 th January, 2016
RESEARCH	Friday, February 19 th , 2016
INITIAL CONCEPT PRESENTATION	Friday, March 19 th , 2016 <i>We will review schedules at this point to determine overall project direction.</i>
SUBMISSION + Final Presentation	TBD
ASSESSMENT CRITERIA	The project assessment will take account of your progression through, RESEARCH (15%) CONCEPTS [Analysis + Development] (35%) Synthesis/RESOLUTION (30%) PRESENTATION/Communication (20%)
TUTOR	Robert Tully

2.b PROYECTO CONTRACT LIGHTING



MORNINGFOG

Jaume Luna Alapont

LIGHTING MARKET STUDY



Bau_normann_VibekeFonnesbergSchmidtv



sisma_karman_matteoUrgolini



ax20_archiproducts_axolight



woud01



wireshare_prodeez_marc-trottereau



woud2



Cap_TableLamp_MidnightBlue



chapiteauLamps_rodeez_Bosa



Rumbles_prodeez_Formaliz3d



RiboneLamps_prodeez_martinZampach

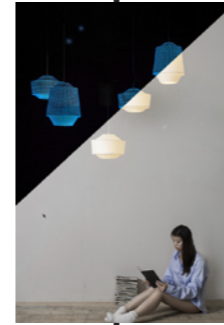

leonaLantern_prodeez



fermliving01



fermliving02



woud4

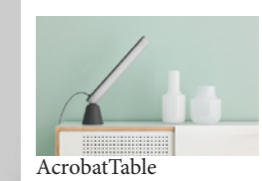

AcrobatTable



woud3



IkonoLamp_normann_Simon-Legald



woud6



Hello_normann_JonasWagell



AmpLamp_Normann_Simon-Legald



Bell_normann_AndreasLund&-JacobRudbeck



Farooo_moooi_marcelWanders



ViseLight_Prodeez_Bec-Brittain



pendant-lamp2_artek_alvaraalto



tomdixon



pendantLamp_artek_alvarAalto



shoji_archiproducts_davideGroppi

Textures

Plane colors



minimikadop_lzf_miguelhernandez

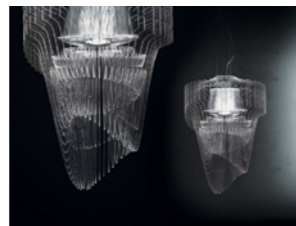

Aira_prodeez_ZahaHadid_for-Slamp



tropic_metallux



lamps_normann_SimonKarkov



crystalrock_prodeez_ariLevy



KinemaPendant_Prodeez_fingerhut



rotini_prodeez_aquacreations

Geometry

Organic forms

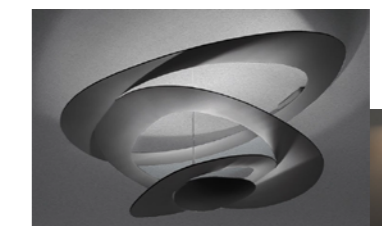

pirce_artemide



acrobat_normann_Marc-Venot

LIGHTING 3/3/16

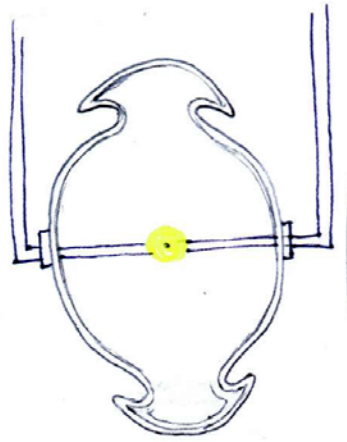

[Look for materials that change a lot with water.]

Capsule completely closed that contains water an spins, so when the water touches the walls the aspect of the light changes and also the light that emits

Plane inclined surface that spins in an axis so reflection changes



Water

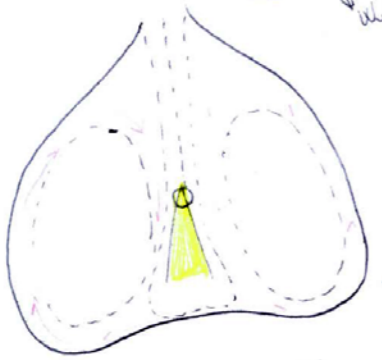

Water flow

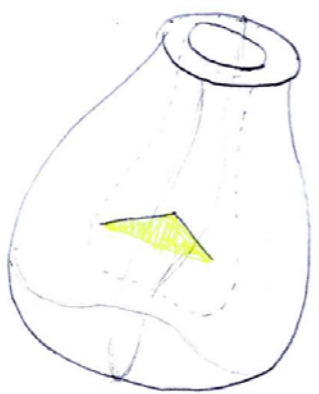

Lamp - floor of water with a lamp on the inside that glow from light heats the bottom part, so water goes up and down the hole time.

And so if there's something in the water, these should make some shadows in the space.

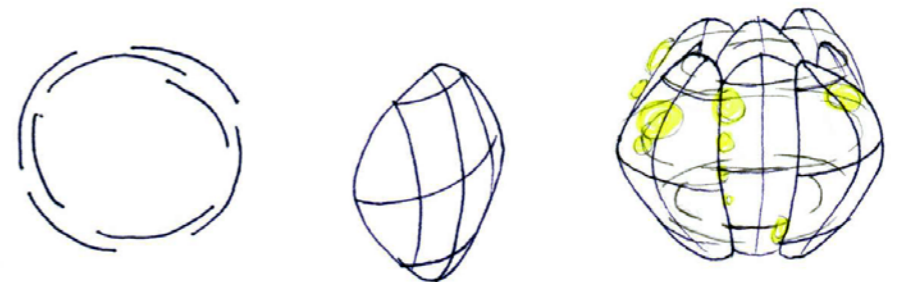
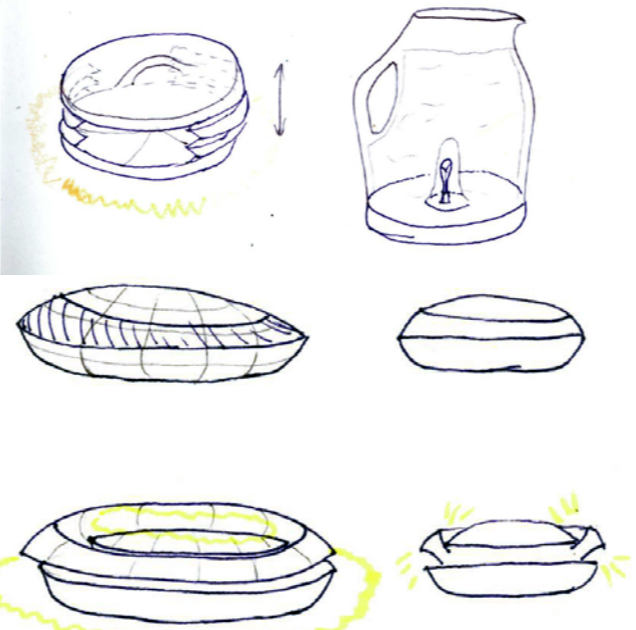
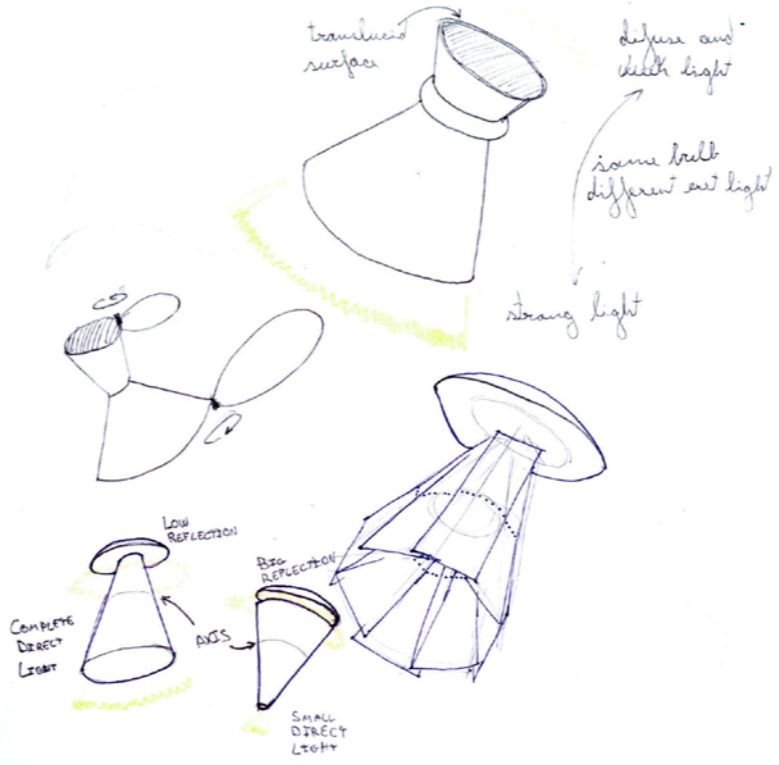
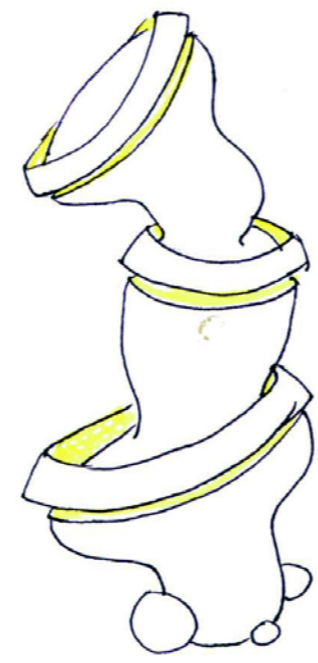
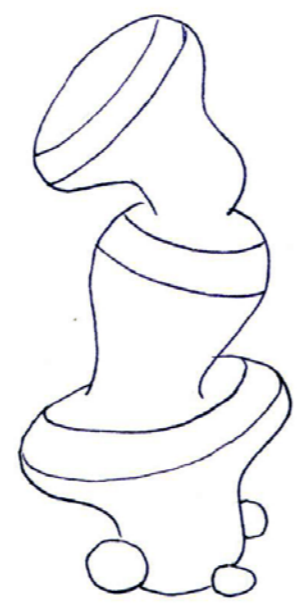

In order to provide few light in open spaces or indoors these expandable lamp using ball luminous bulb has long arms that can be attached to the central body

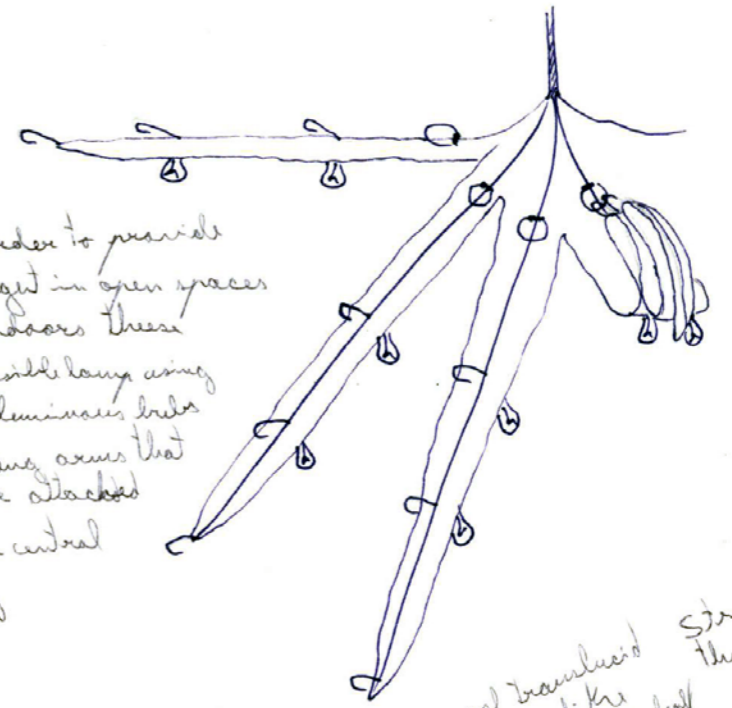

cool translucent jellyfish or jumbo hat
Strong wire sculpture that allows more resist. while moving the lamps

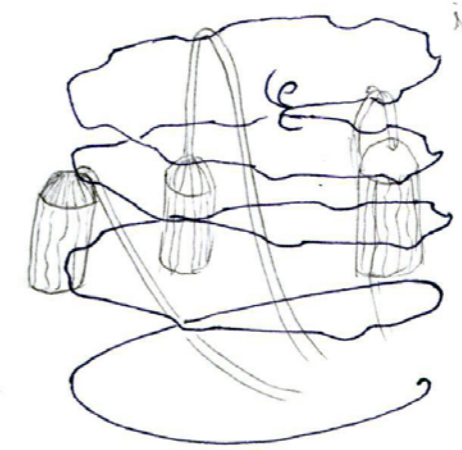

easy to move and place all around the base or even on the table

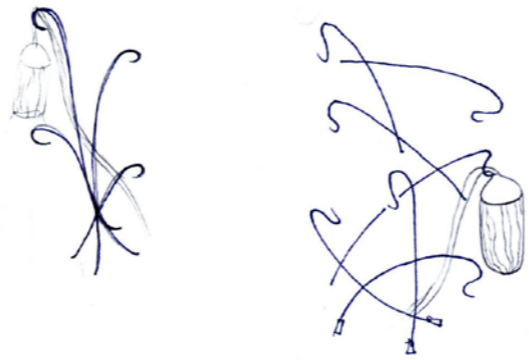

Very strong but diffuse light, the children can walk around home with no shadows, an alert of everything that's happening (no scared)



lamp connected to the wires that turns into a stick that holds the silicone (translucent) "leaves" that can be opened to get direct light

These leaves can be put in the table since has 3 support points or bases hanging from a base, since the beginning of the wire has a curve rigid

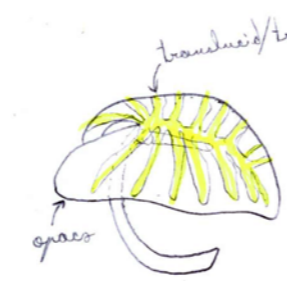
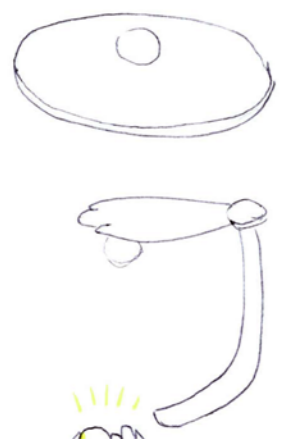

Indirect light putting something in front of the light origin

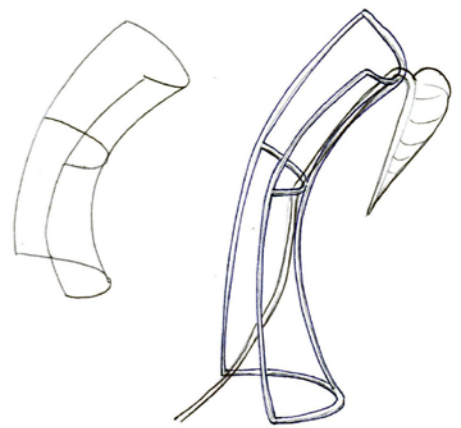

Elas amb optas les optas poden ser línies de líes o parats coberts per cristalls, y els pitos s'han de que siguin translucents

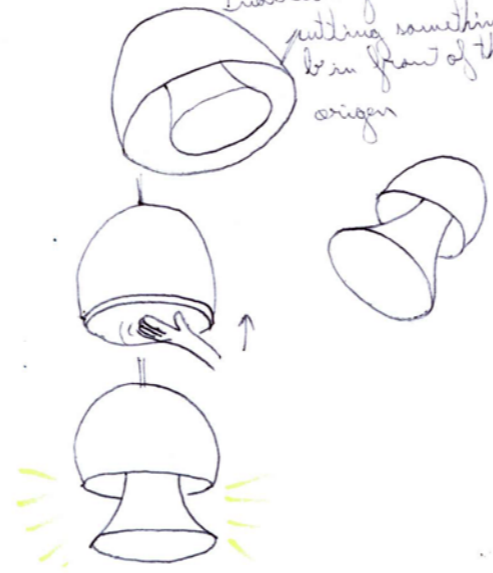
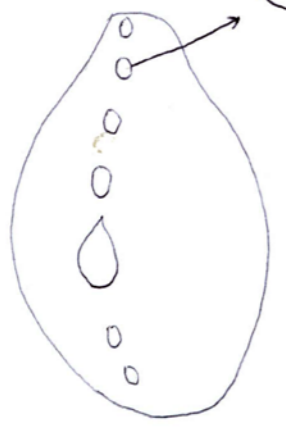

base for the leaf lamp wire

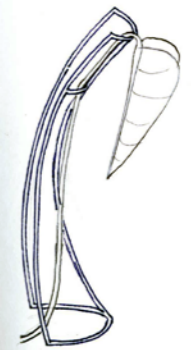

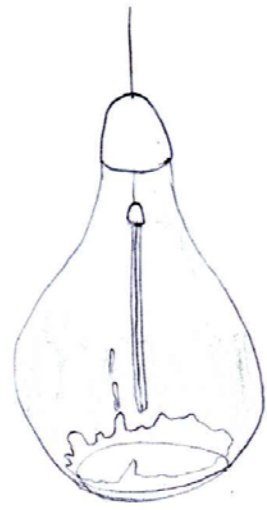

Play with the concept of distance from the focus, glass opacity and the morning fog representation.

Have the focus near to the glass top representing the sky (orange or white light) then the distance to the focus increases so the glass is whiter representing the fog and in the bottom is transparent glass representing the water drops and also making shadows

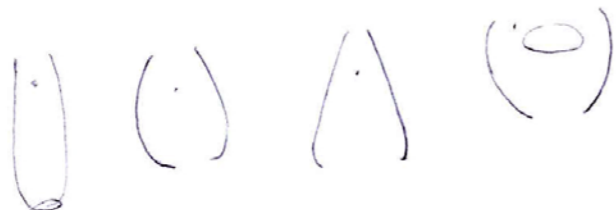

LARE



Proximity to the focus of light in the lamp cover will make different intensities of the colour of the cover.

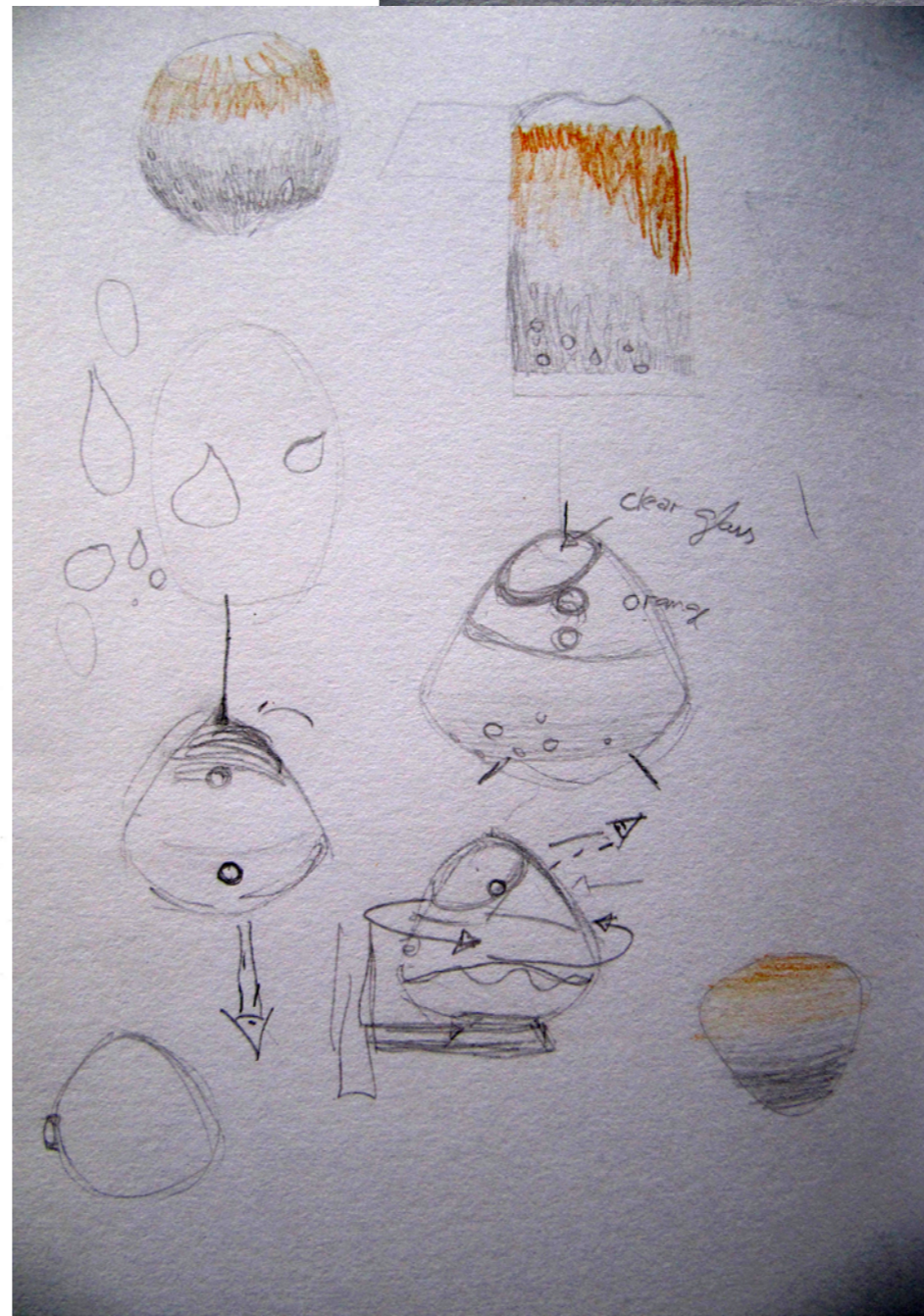
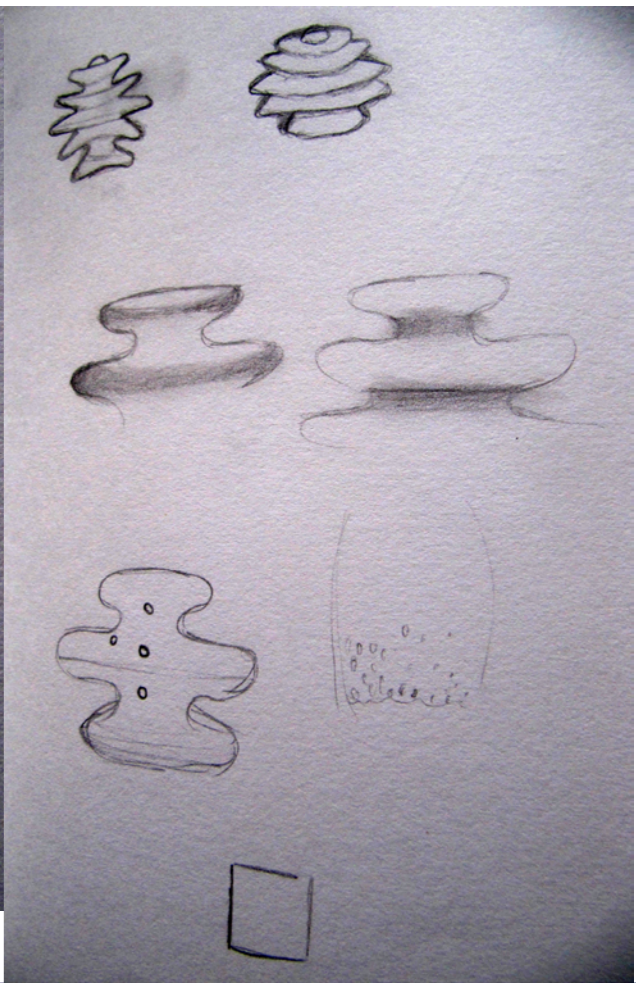
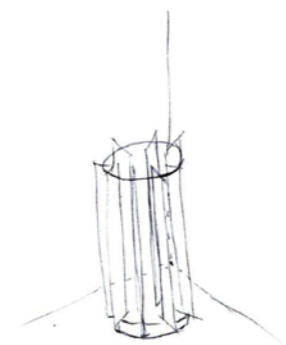
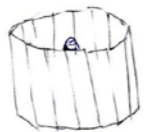

for the table lamp the user is gonna lean from the side and the morning fog/sky in translucent shell, but in the evening the shape changes in order to transmit the same effect

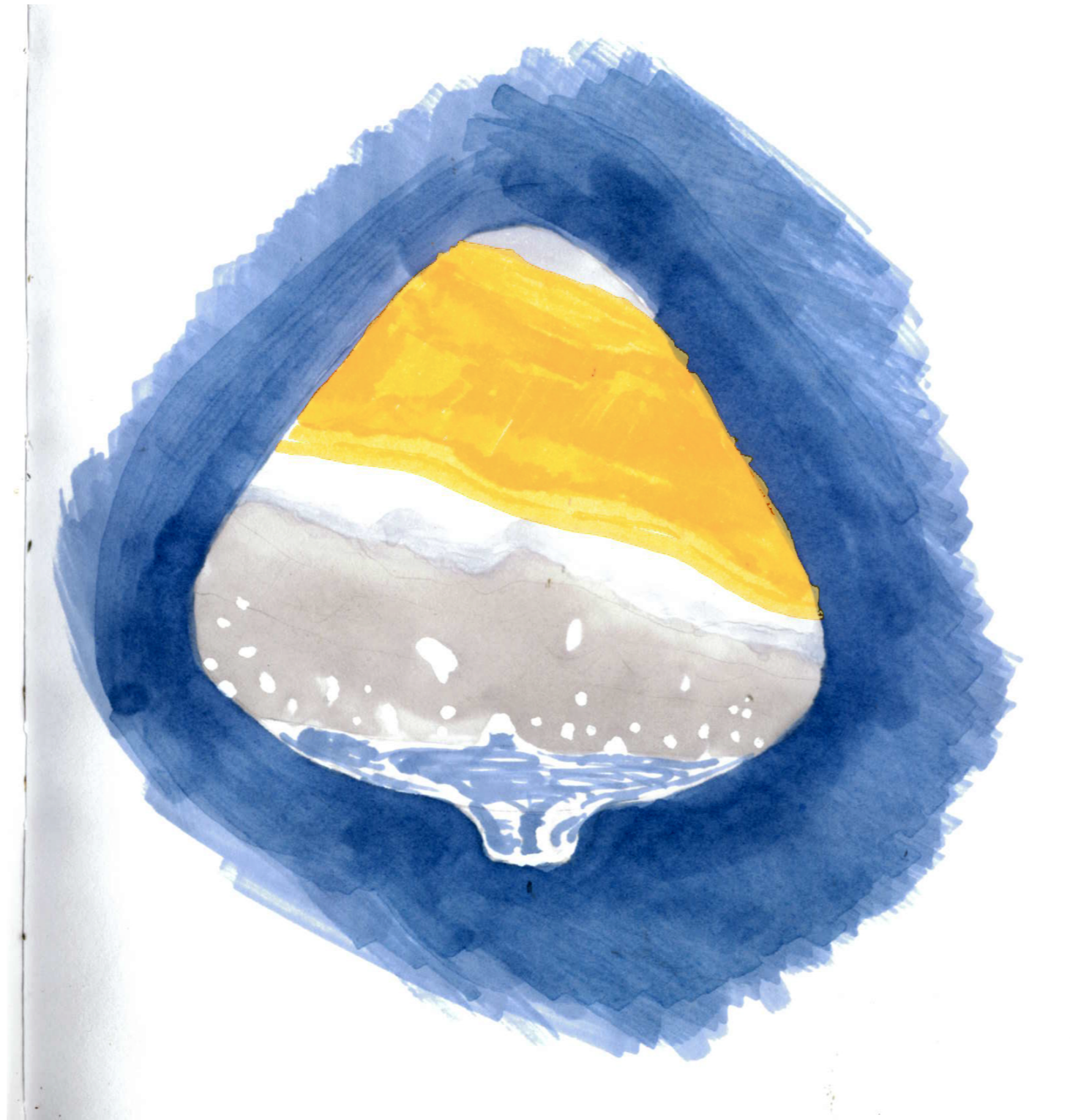

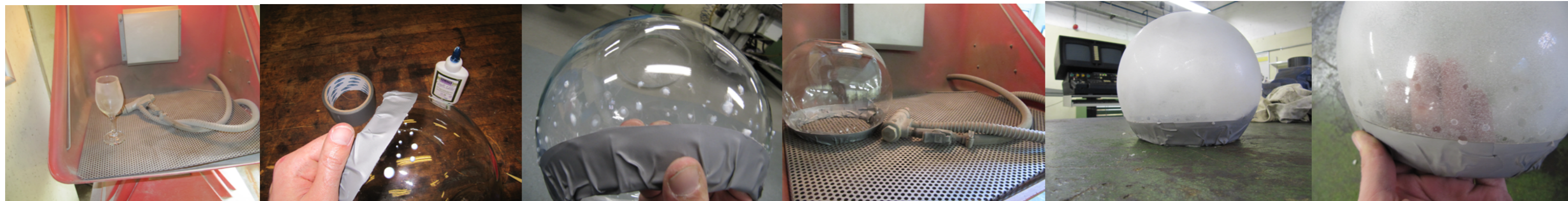
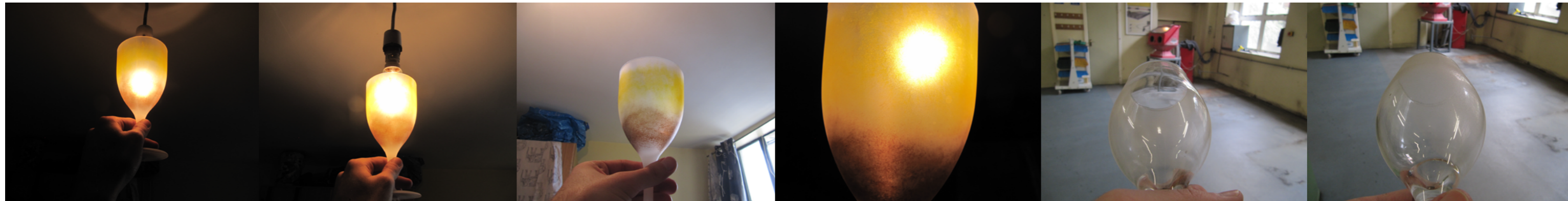
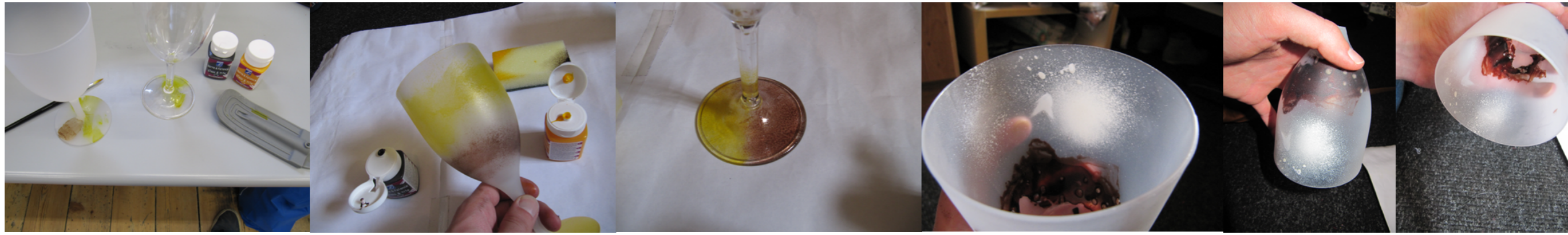





The lamp leg is conformed of two parts, in order to have a rotation mechanism. That allows the user to choose the part of the light cover desired in order to change the light colour or make it darker, it's because of that, the glass is coloured and foggy in an irregular way.

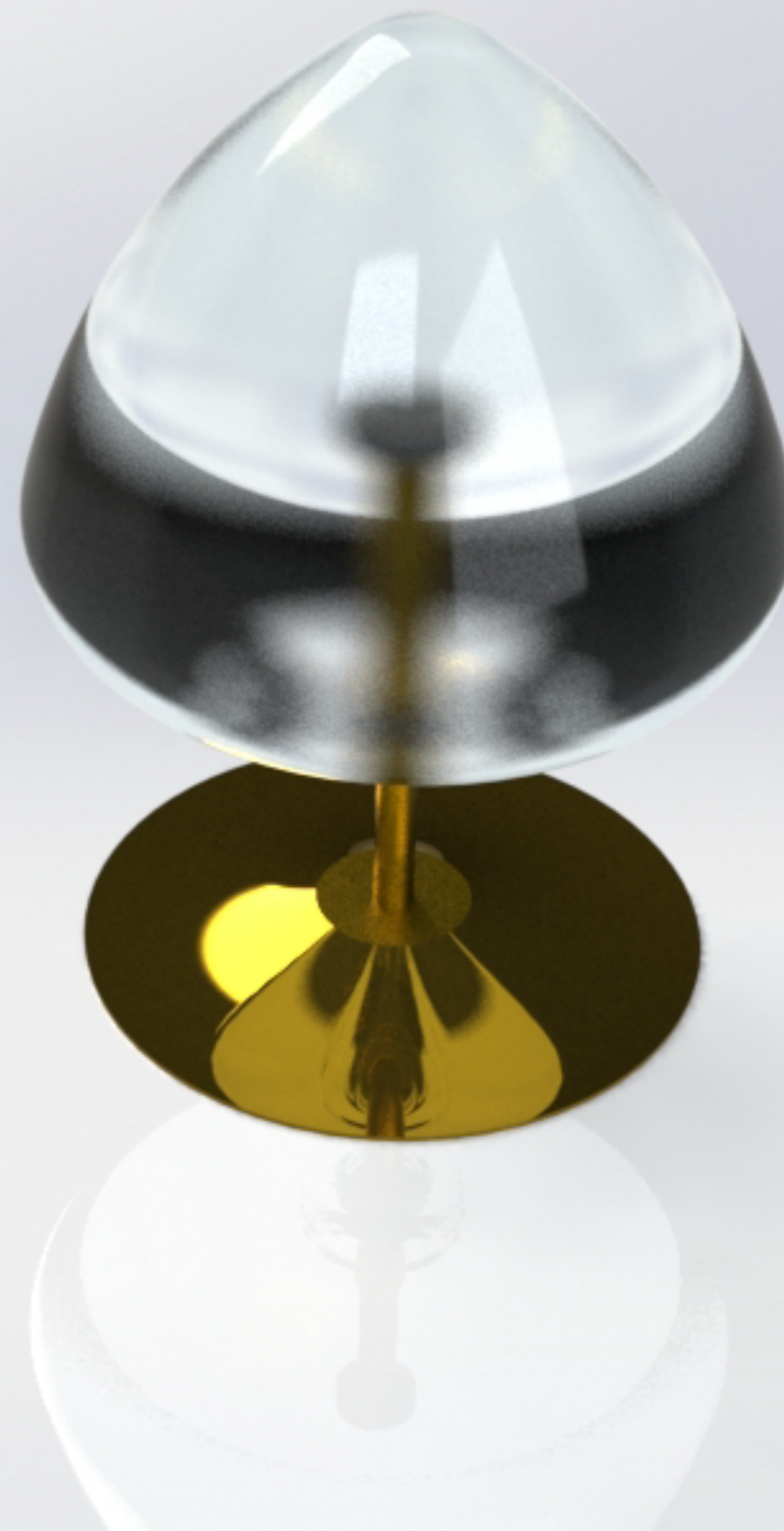

8

7

6

5

4

3

2

1

F

F

E

E

D

D

C

C

B

B

A

A

1

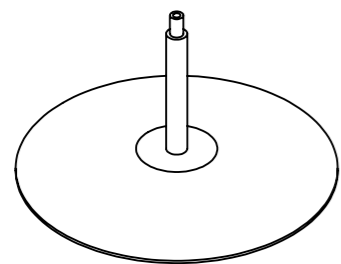

2

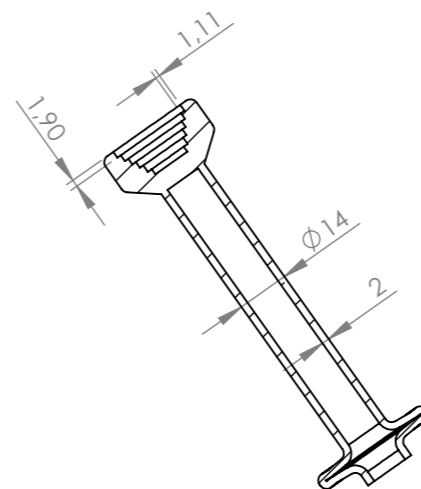
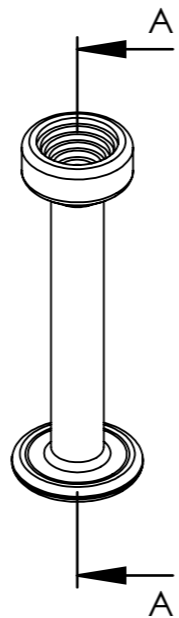

Section A-A
scale 1 : 2

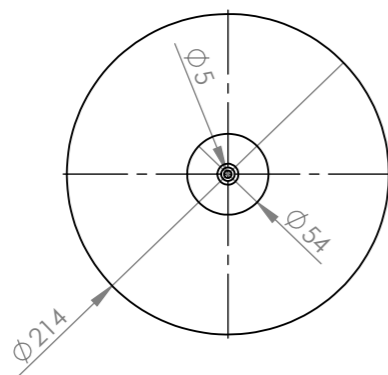
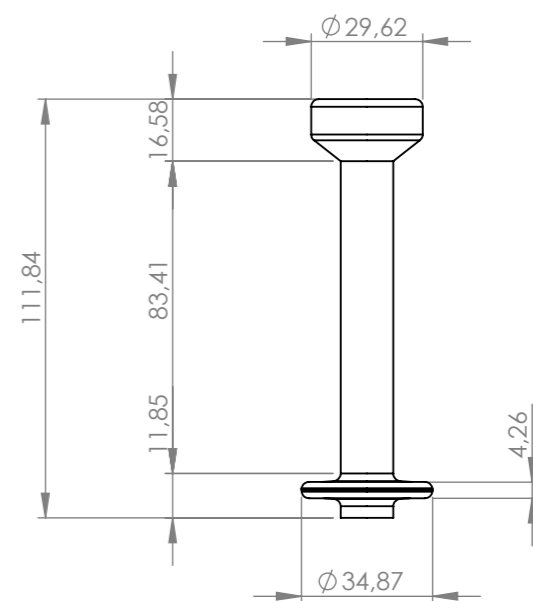
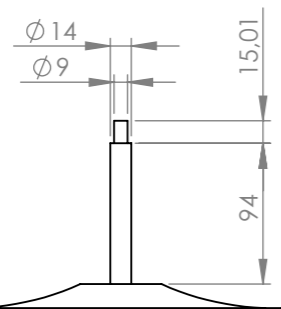
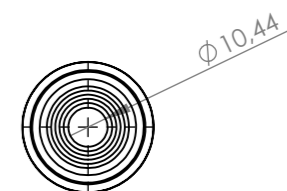

No	PART	MATERIAL
1	Lower leg part	Polished and old brass
2	Upper leg part	Old brass and rubber

MorningFog

Plane 1

A3

scale 1:5

1 of 3

8

7

6

5

4

3

2

1

3

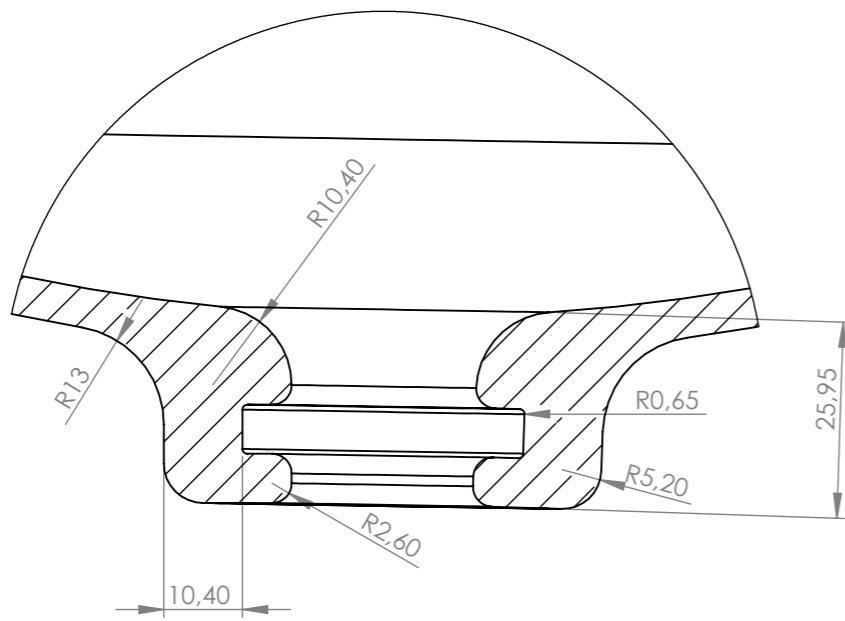
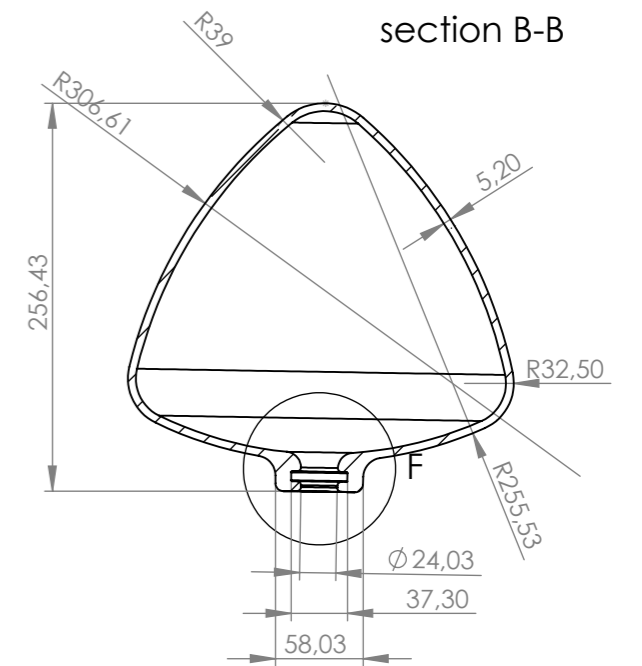
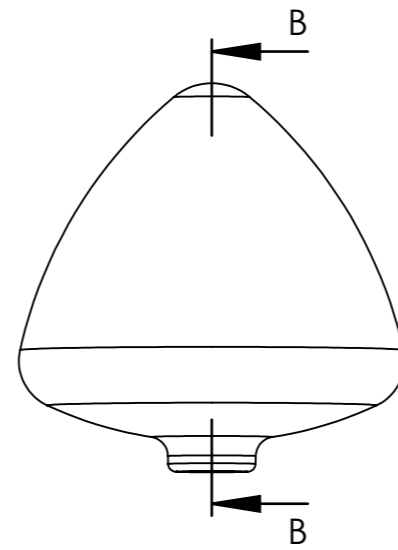
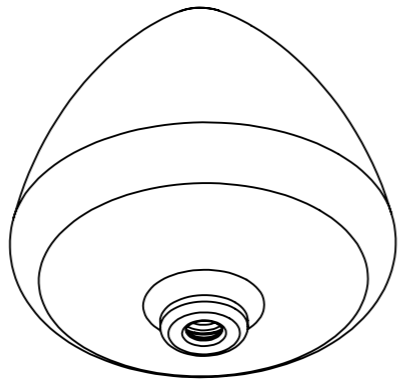

detail F
scale 1 : 1

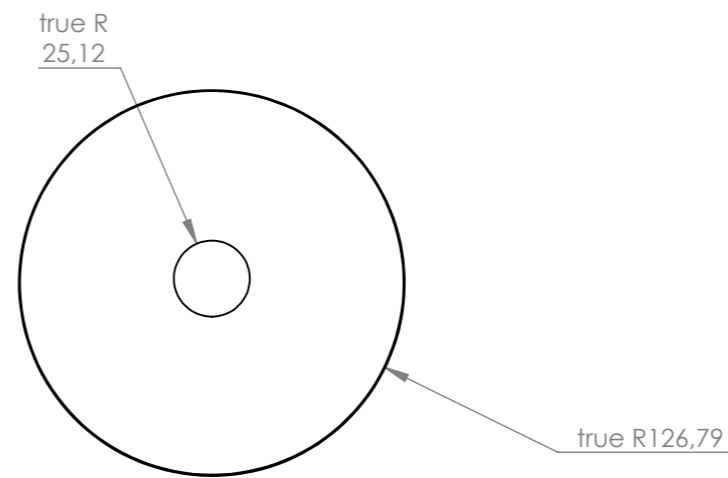

No	PART	MATERIAL
3	Light cover	Coloured class
MorningFog		Plane 2
scale 1:5		2 of 3

A3

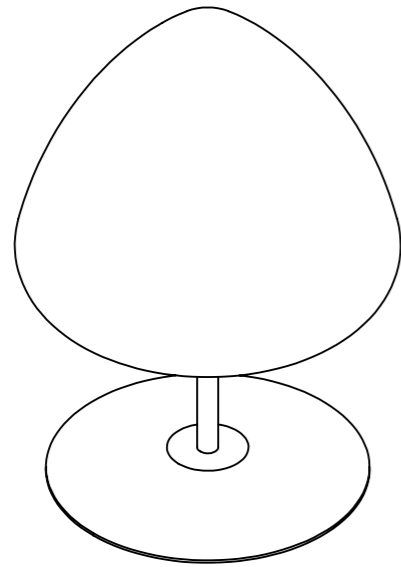

Spinning mechanism similar to the ones used in the metal leg spinning stools.

Also the subsection rubber part of the upper leg part to subject the glass is shown in this section.

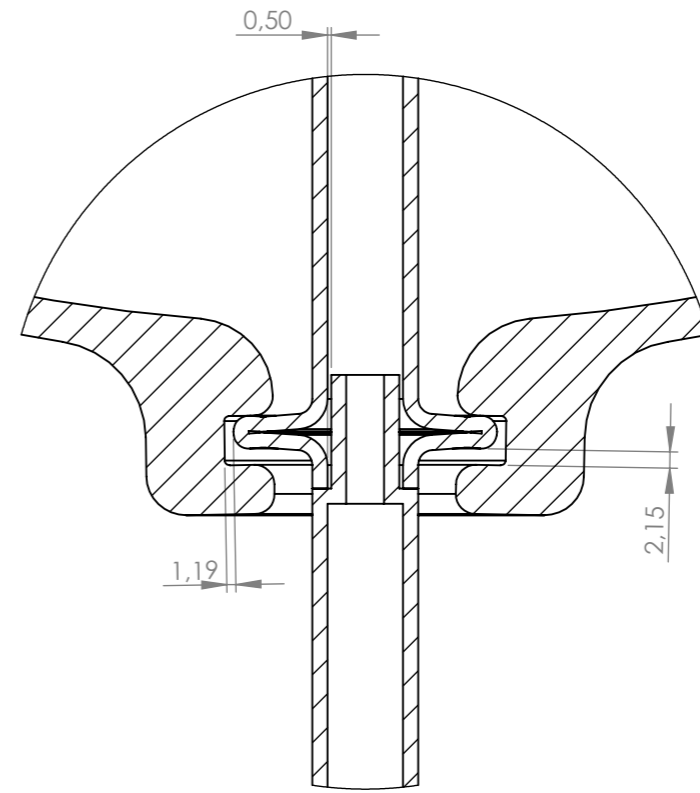

detail E
scale 1 : 1

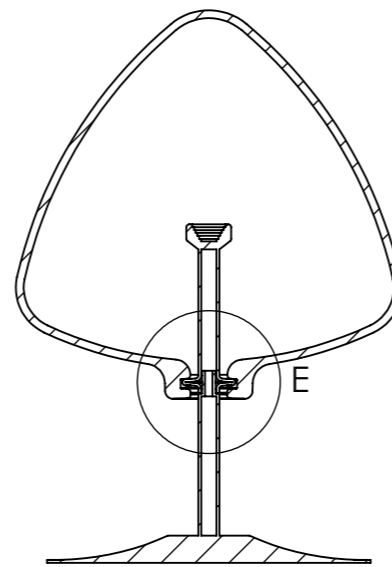
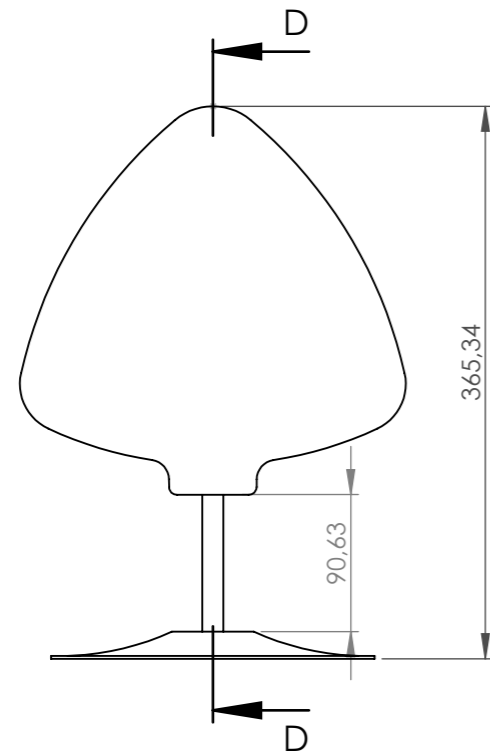

section D-D
scale 1 : 5

3. RAPID PRODUCT DEVELOPMENT

En esta asignatura se estudian y ponen en práctica muchos de los procesos de prototipado rápido que se utilizan en los procesos de diseño.

Para ello se lleva a cabo el montaje de un coche de juguete utilizando las maquinas del taller de diseño disponibles en la universidad DIT.

Algunos de los procesos son corte por láser, termoconformado, impresión 3D, escaneado 3D, etc.

3.a BRIEFING PROYECTO

DT001/2 - Rapid Product Development

Prototyping Techniques: Project Brief and Schedule

This project carries 60% of the grade for the RPD module.

In this project, you be given a small electric motor, a switch and battery connections. You will then work as a team using a variety of prototyping techniques to design, develop and produce a final prototype for an **electrically powered four wheeled vehicle toy**.

You will initially draft schematics of the vehicle, considering all factors in your design. You will then produce several generations of sketch models to prove your ideas. Once your design has been frozen and drafted using 3D CAD, you will proceed to final prototyping.

Items to consider:

- Scale of the vehicle.
- Mounting of the provided 3V DC motor and battery pack.
- Mounting of axels and wheels
- Tyre surfaces.
- Gearing between motor and wheels.
- Clearance for wheel rotation and steering.

Suggested components:

- Chassis:
 - Provides a stable mounting point for two axles, all electrical components and the external bodywork.
 - Suggested material and process: Sheet HIPS / Laser cut and bend.
- Brackets / Bushing Housings:
 - May be fixed to the chassis, provide removable mounting points for the electrical components and the external bodywork
 - Suggested material and process: 3D Print (PLA).
- Bushings:
 - Provide low friction interface between rotating axles and stationary chassis.
 - Suggested material and process: Acrylic (Source externally (radionics.ie))/ 3D Print (PLA).
- External Bodywork:
 - Covers the chassis and styles the vehicle.
 - Geometry should be based upon a laser scan of a clay vehicle model which one of the team produced in the Modelmaking and Rendering module.
 - Suggested material and process: Laser Scan / Vacuum Forming

All components need to be produced in a repeatable, cost effective manner.

Detailed Weekly Schedule

		Project Stage	Deliverables
	Week 1		
	Week 2		
	Week 3	Project Brief Issued: Provided with kit hardware. SW Model: Chassis layout – Wheelbase and Track based on external bodywork to be scanned	
	Week 4	SW Model: Design mounting points	
	Week 5	SW Model: Initial Surface design for bodywork	
	Week 6	Chassis Lo-Fi Prototype – Cardboard (cut and bend). Motor, Axle and Battery mounting points – Foamboard, Sculpture. Bodywork – Blue foam, Card/ Paper	
	Week 7	Freeze design	Lo-fi / Foam models of all components Portfolio – final design images
	Week 8	Prototyping Studio	
		Easter Break	
		Easter Break	
	Week 9	Prototyping Studio	
	Week 10	Prototyping Studio	
	Week 11	Final prototypes and posters	Prototype Components complete & assembled.
	Week 12	Prepare presentation, posters & prototypes and finalise wiki	
	Week 13	Final Presentation	Finished portfolio outlining design and build.

Schedule of Project Deliverables

- **Week 6:** Presentation of your **final vehicle design** through two A3 boards showing virtual models of all components and assemblies. You will also produce lo-fi sketch models of all components, also assembled where appropriate. *NOTE: Teams who do not produce sketch models of components will not be permitted to proceed to the final prototyping stage.*

- **Week 13:** Presentation of your **final vehicle design and prototype.**
 - **Portfolio** (A3 landscape) should include conceptual and development work along with graphical and text-based descriptions of your prototype and the design and manufacturing methods used to produce it.
 - Conceptual & Development: We would expect to see a series of schematic drawings, sketches, model studies and hand rendered images (typ. 4 pages)
 - Final Design: Screenshots and renders of your final virtual assembly (typ. 2 pages)
 - Prototype: Document and critique the processes used to produce each component of your prototype. (typ. 8 pages)
 - Final Prototype Views: professionally presented images of your prototype taken against a plain background (typ. 4 pages)

 - **Prototype** should be professionally produced and finished and employ the full variety of prototyping processes described in the module.

3.b PROYECTO

RPDV Car

*Jaume Luna, Daire Lonergan,
Callum Leneman*

6 May 2016
DT001-2
Rapid Product Development
Colm O'Kane
Spring 2016



Concept Development

The Brief

In this project, you will be given a small electric motor, a switch, and battery connections. You will then work as a team using a variety of prototyping techniques to design, develop, and produce a final prototype for an electrically powered four wheeled vehicle toy.

You will initially draft schematics of the vehicle, considering all factors in your design. You will then produce several generations of sketch models to prove your ideas. Once your design has been frozen and drafted using 3D CAD, you will proceed to final prototyping.

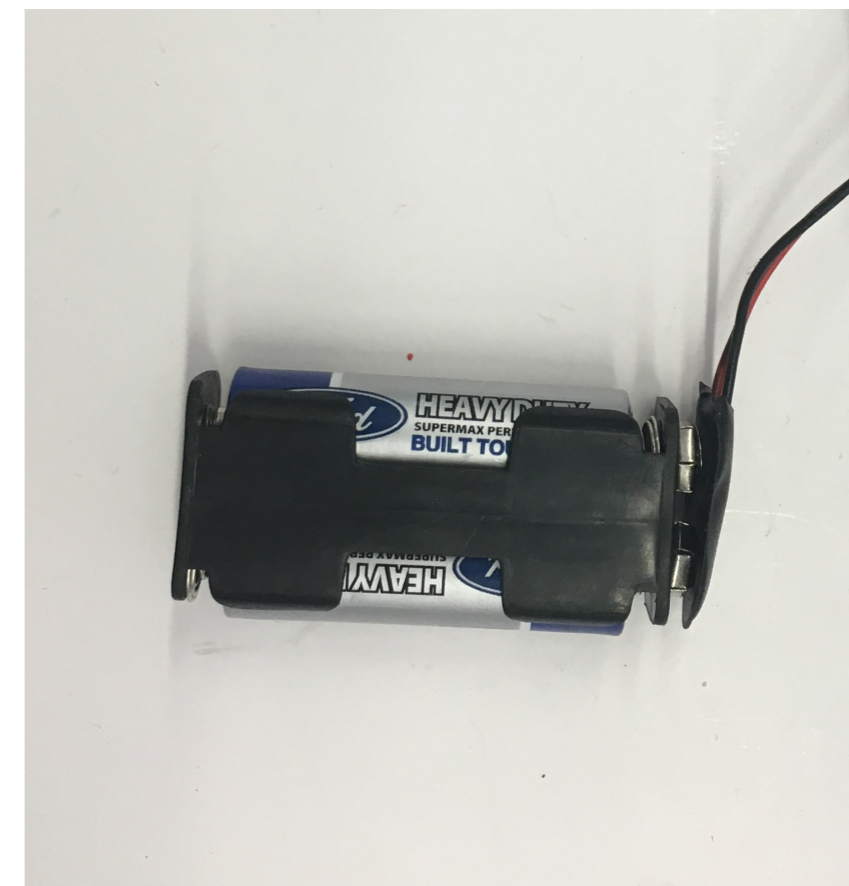
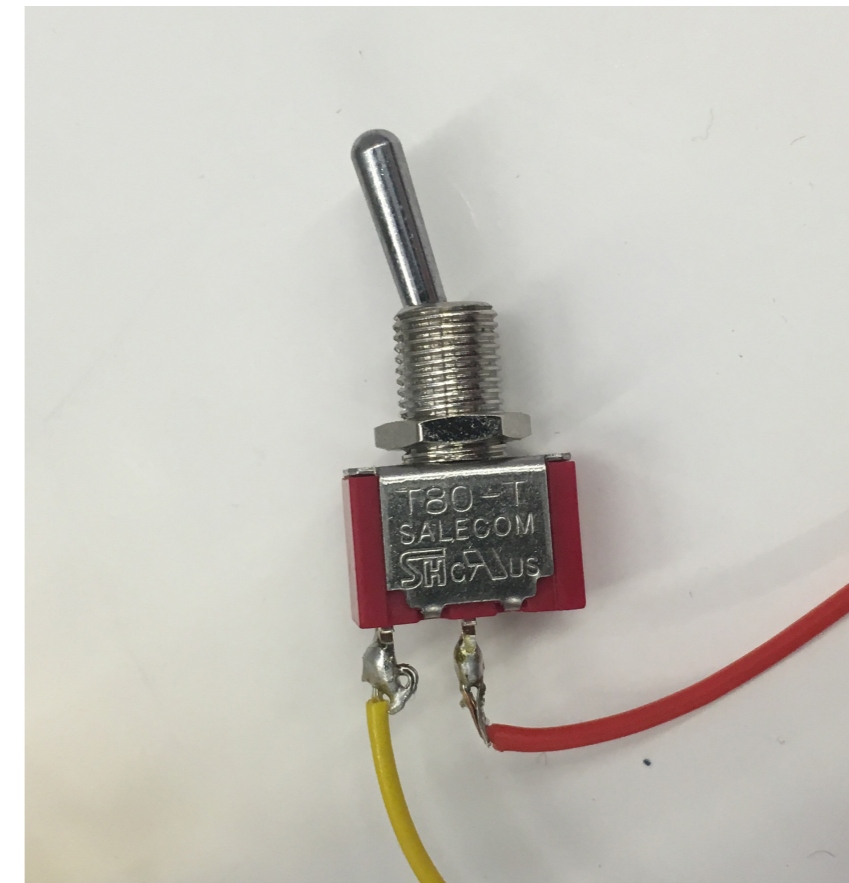

Concept Development

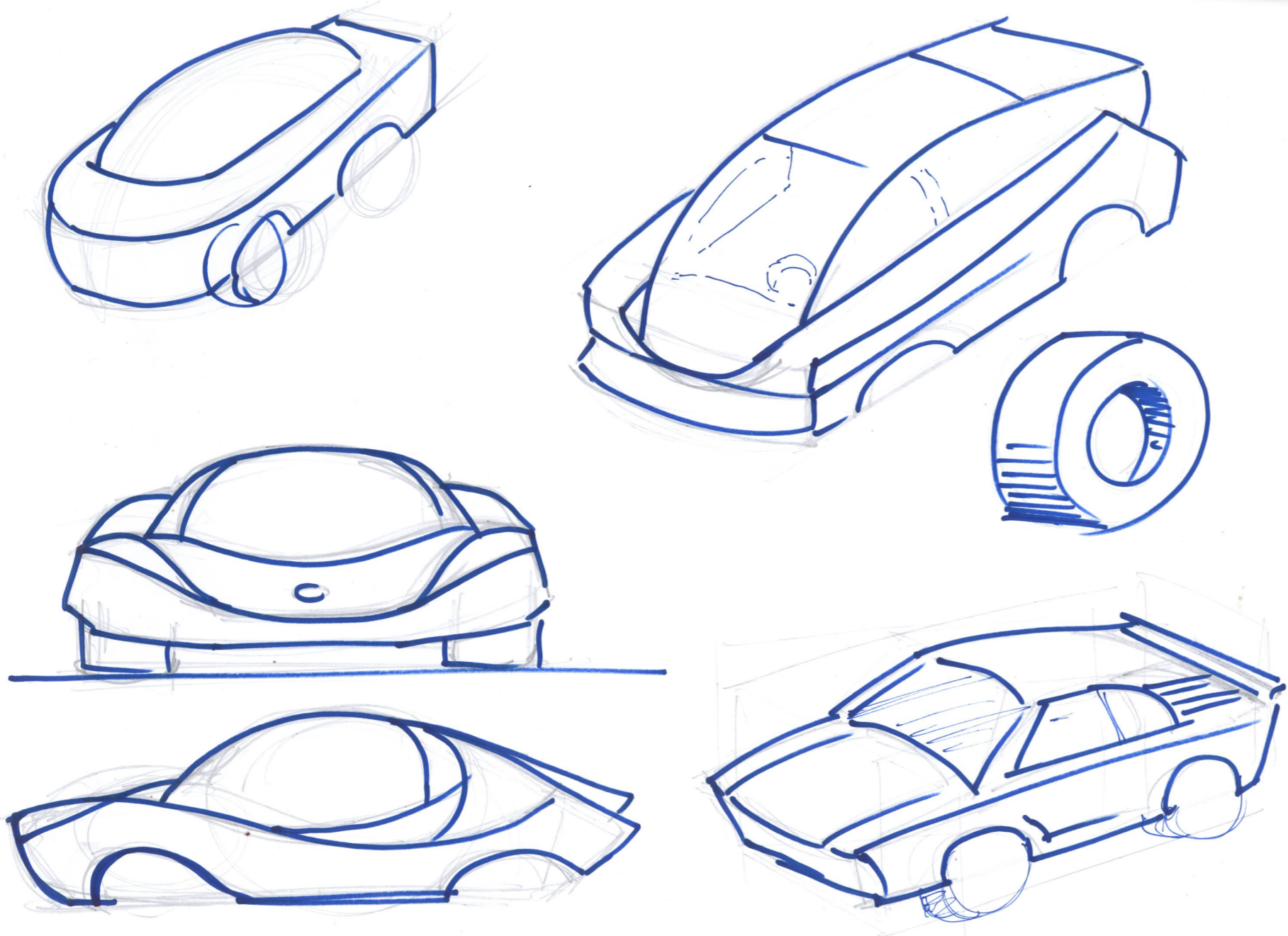

We began by individually sketching concepts for the general form of the car. The forms were based on profiles of performance cars, which are low and wide. These were then paired back and modified to include enough interior space to accommodate the necessary mechanisms.

Concept Development

Once a concept was selected, several iterations were developed to ensure the easiest vacuum forming process.

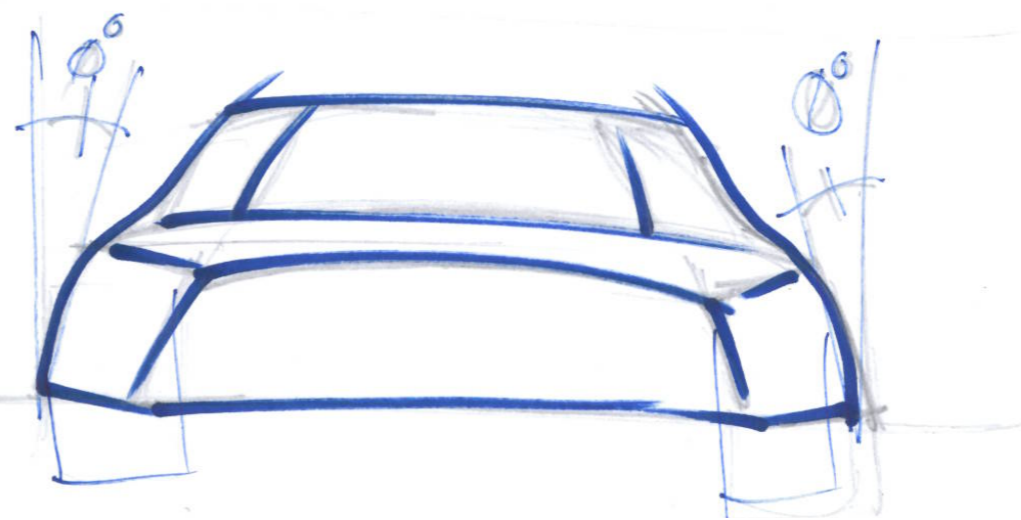
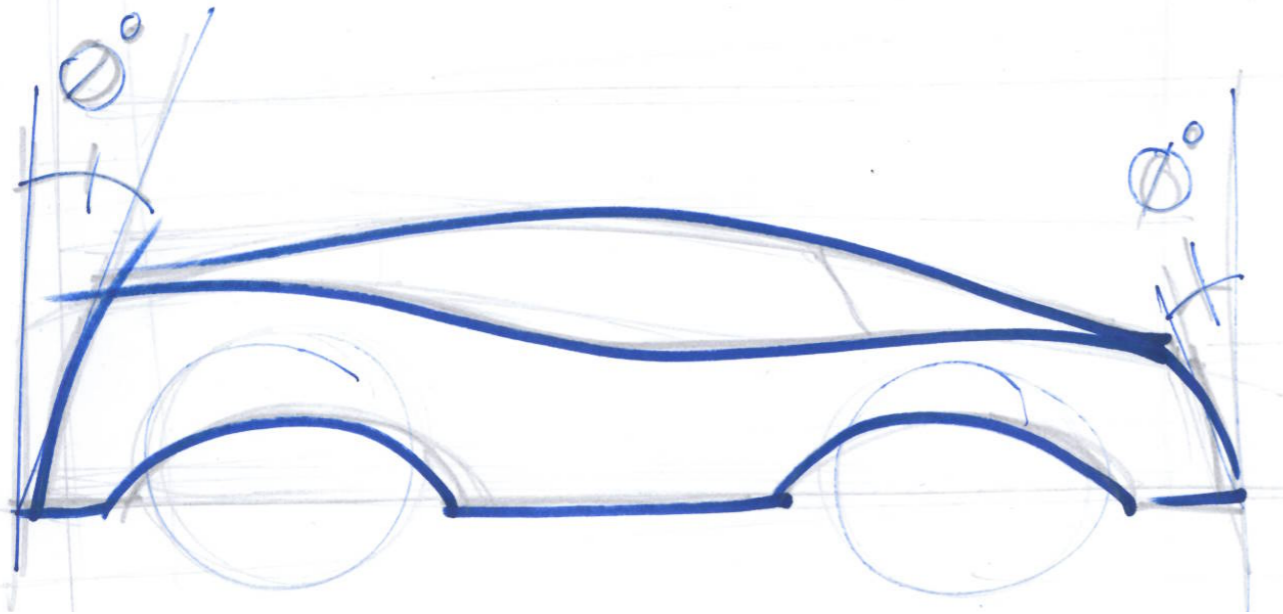
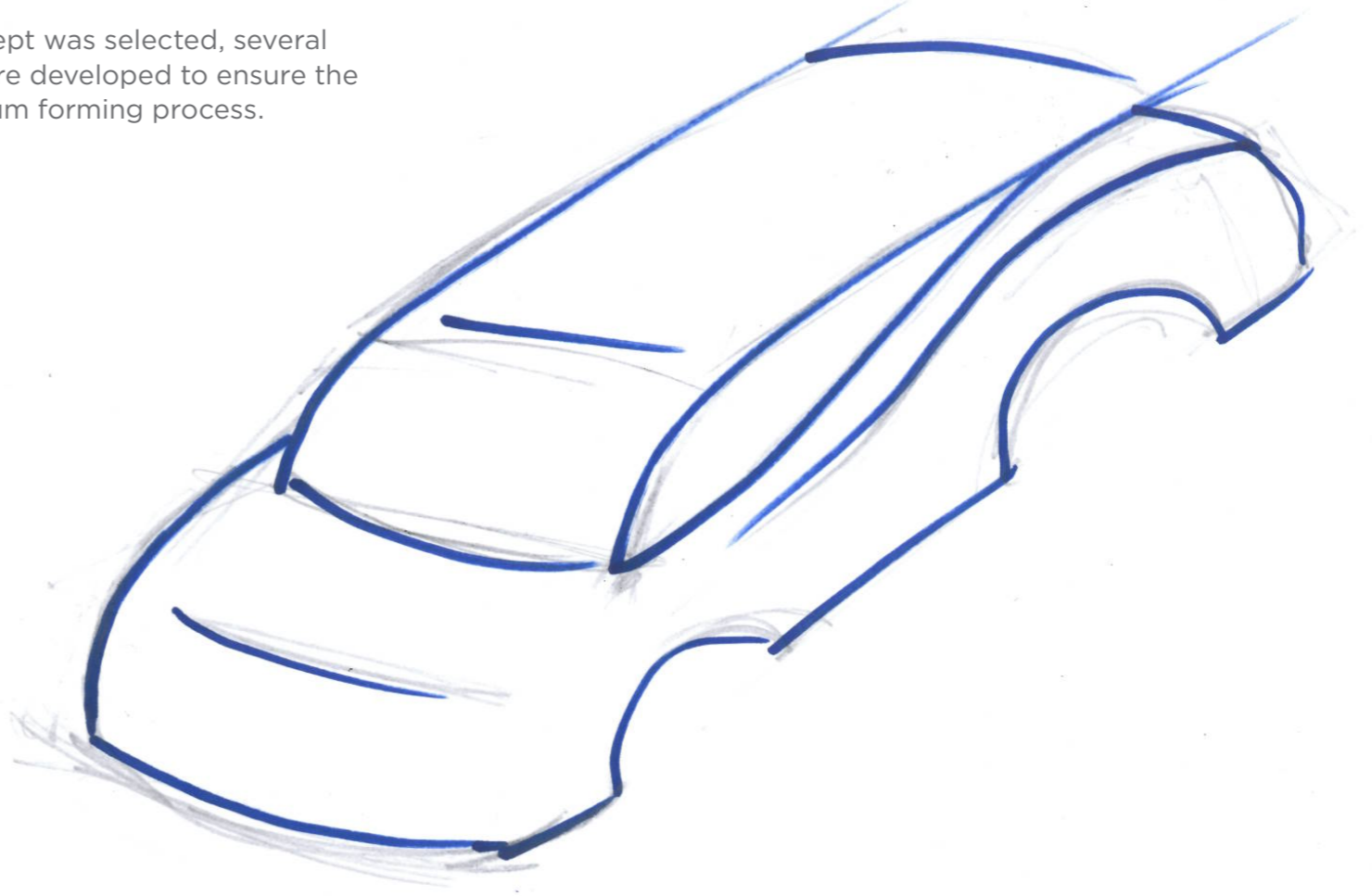
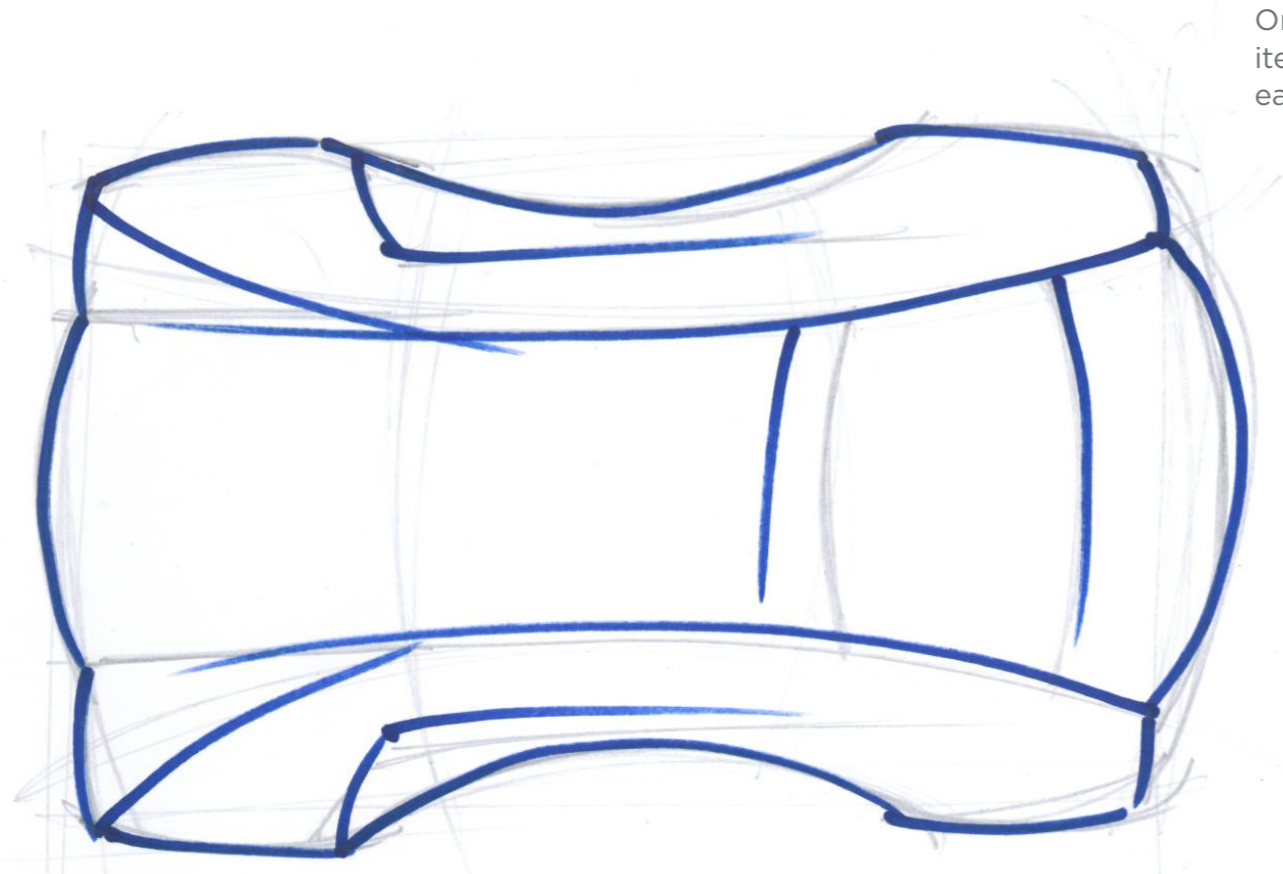

Concept Development

Finally, the various mechanical parts needed to drive the vehicle were developed. Each was specifically designed to be easily printed with the available FDM printers, while maintaining accuracy in the essential components.

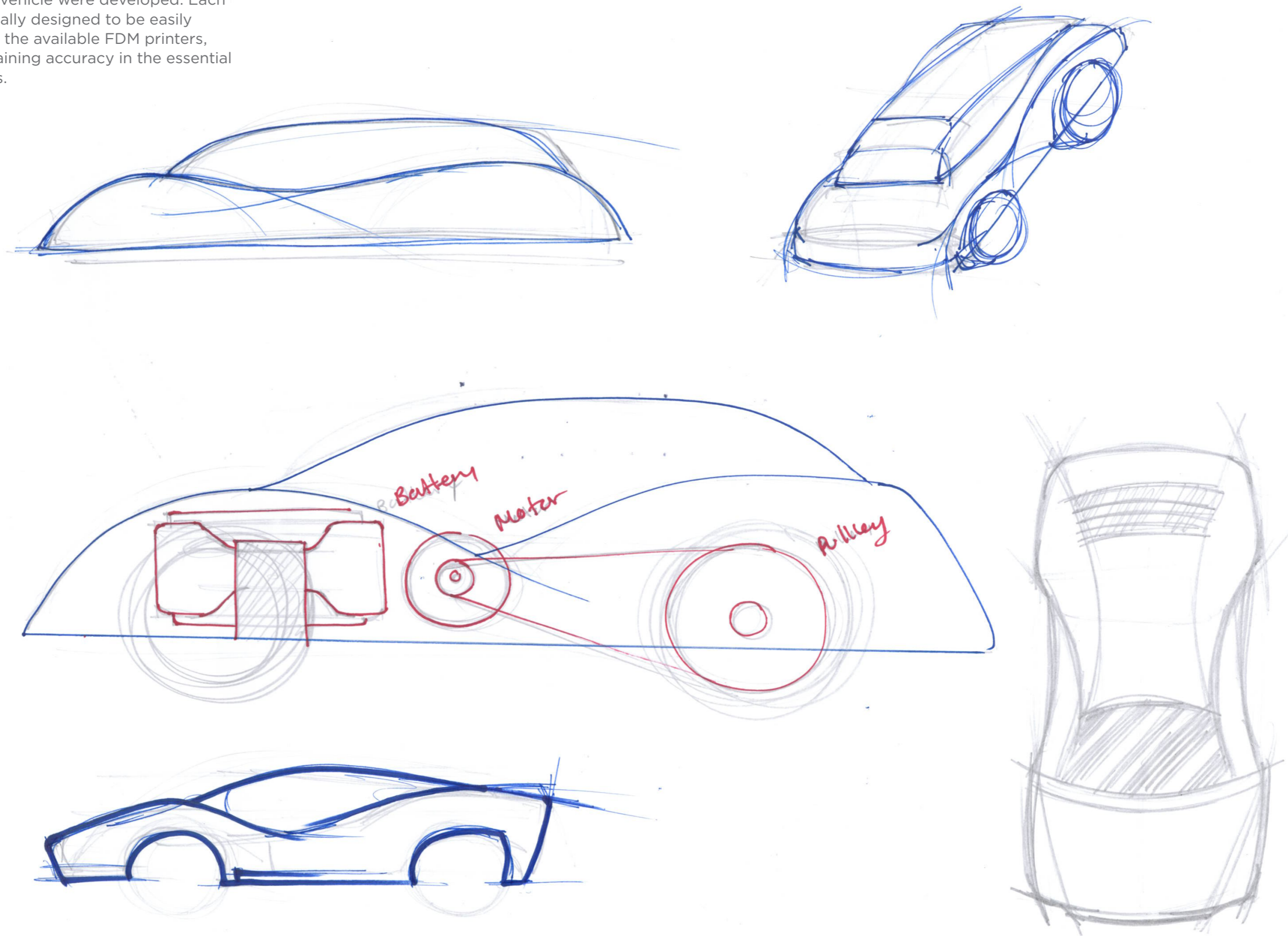

Final Design

When designing our car, we wanted to make sure it was **lightweight**, **stable**, and **aerodynamic**. To achieve this, we began with a sleek body shape, which we loosely modeled off that of a Lamborghini. We kept it as low-profile as possible, leaving very little room between the hidden components and the body shell.

We made sure to make each of the axle mounts adjustable, and secure them all to the same un-altered plate, to ensure that the car rolls straight.

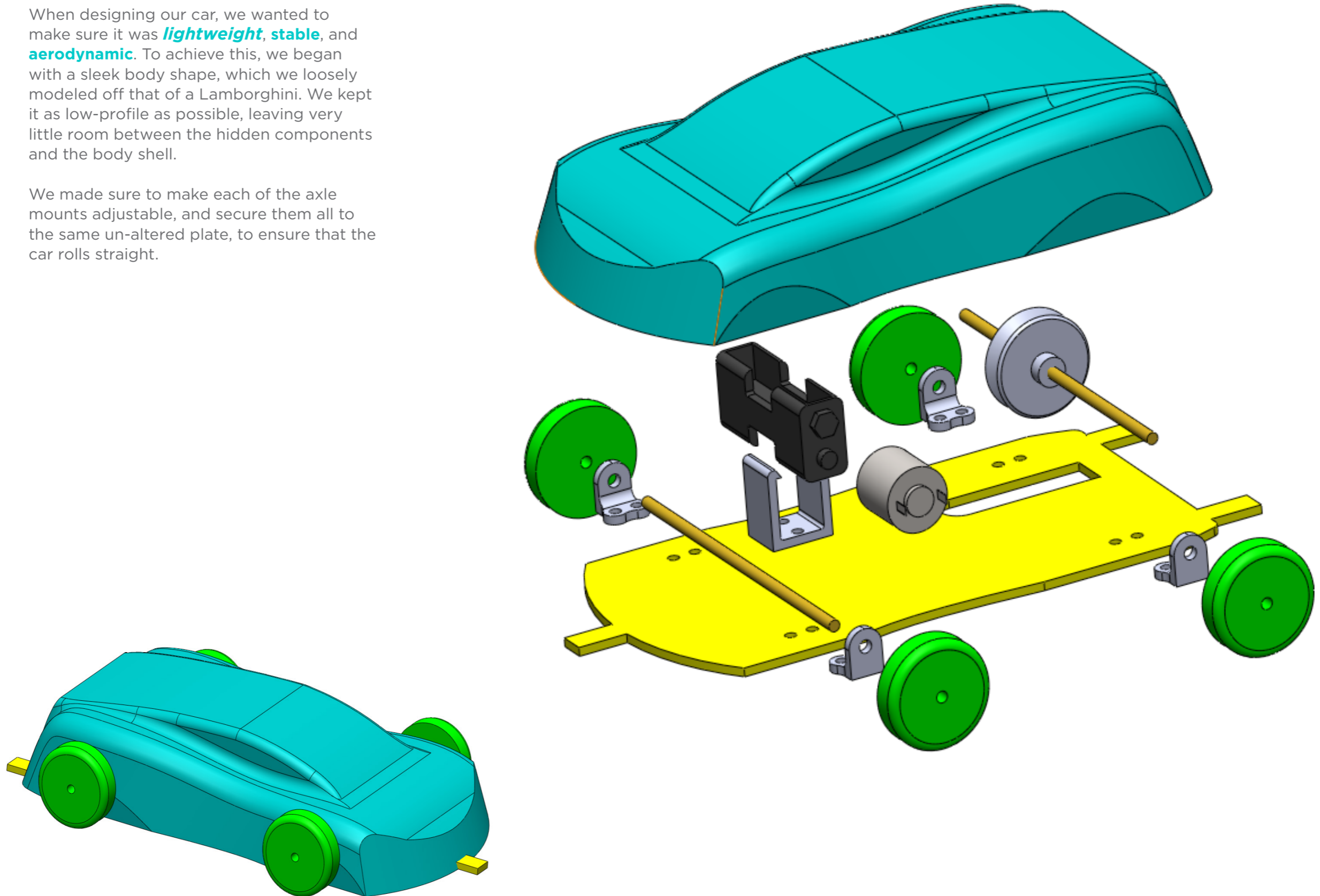

Final Design

We chose to use the motor, battery pack, switch, wheels, motor mount, axles, and pulley that were provided to us, leaving the body, chassis, battery mount, and axle mounts for us to design and make our selves.

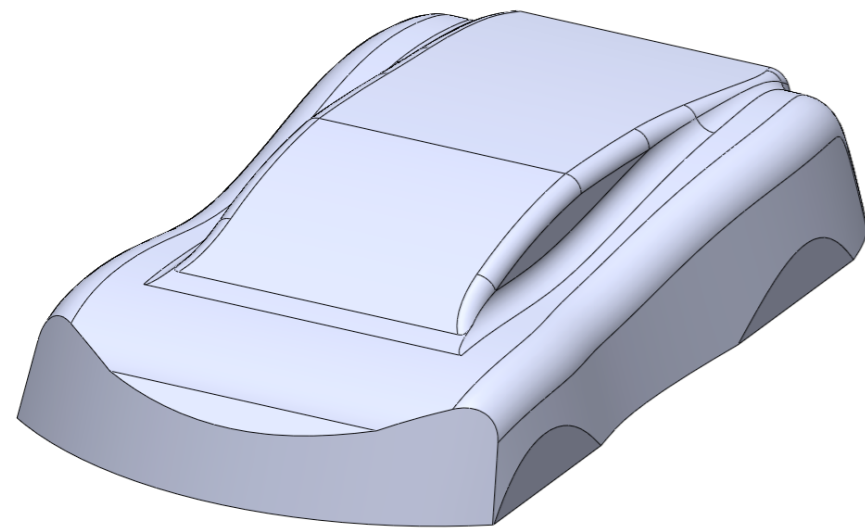

Body

POWDER-PRINTED

This model was originally made in SolidWorks, then shaped from extruded polystyrene foam, 3D scanned, cleaned up in MeshMaker, and printed in powder. The printed form will serve as a core to vacuum form a shell on top of.

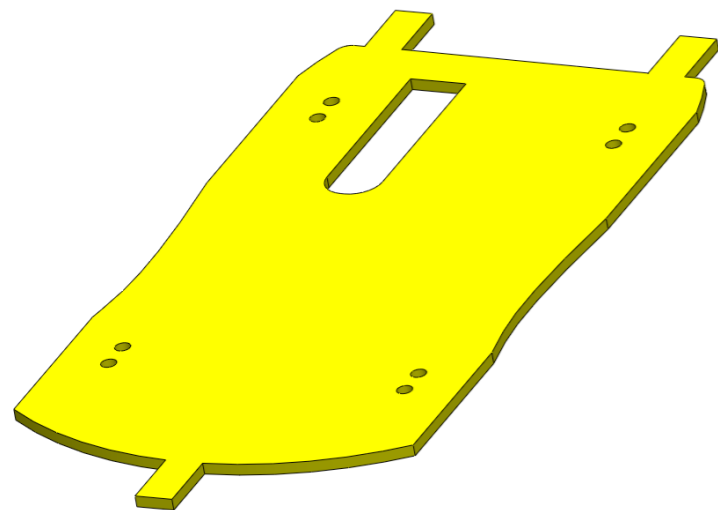

Chassis

LASER-CUT

This part was derived from the footprint of our body. The tabs on either end will be heated on the strip heater, and bent to fasten the body to the chassis. The oval hole allows the rear axle pulley to sit in line with the wheels. 8 holes have been pre-cut to attach the 4 axle mounts.

Battery mount

FDM PRINTED

This part will be used to clip the battery pack housing to the chassis. The walls bend outward to allow the teeth to spread past a notch in the battery pack, and keep it firmly attached. Two holes in the base have been left for screws to attach the mount to the chassis.

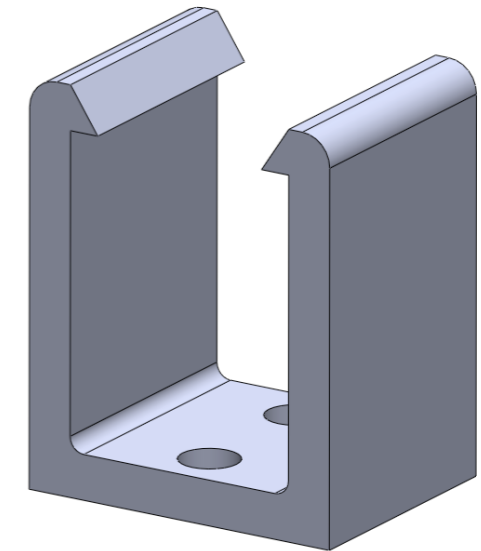

Axle mount

FDM PRINTED

This part will be used to mount the axle to the chassis. The larger single hole was printed face down to ensure maximum accuracy, and allow the axle to spin in it freely. Two more holes are left to hold the mounts to the chassis.

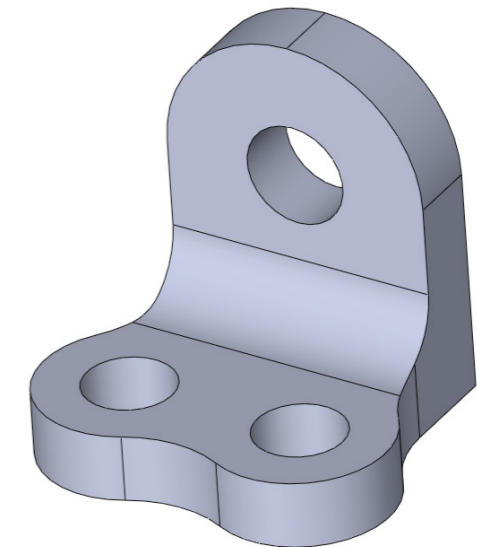

Prototype

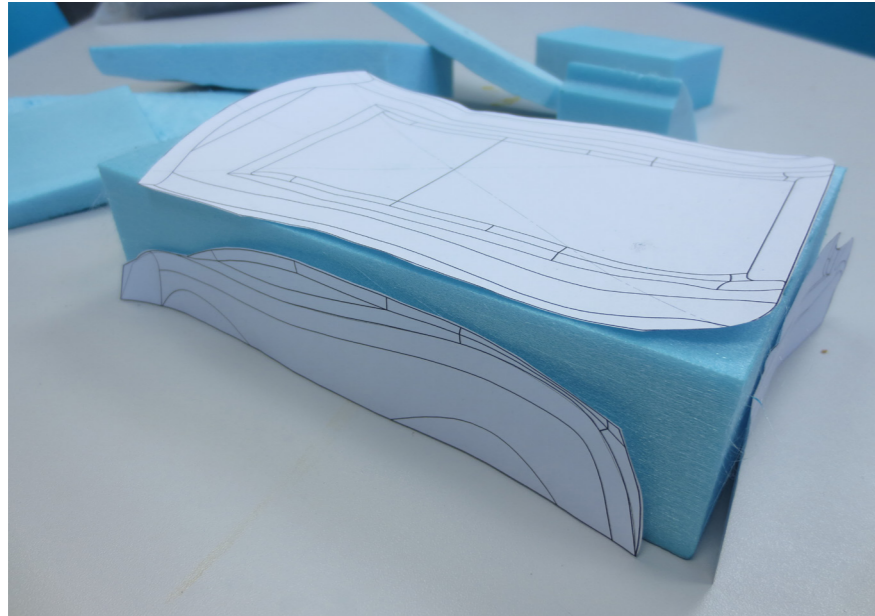

Once the solidworks model had been agreed upon and finalized, the orthographic views were printed, and mounted to a block of blue foam, which was trimmed to the approximate length, width, and height of the car. Each profile was then cut as accurately as possible with the hot wire cutter.

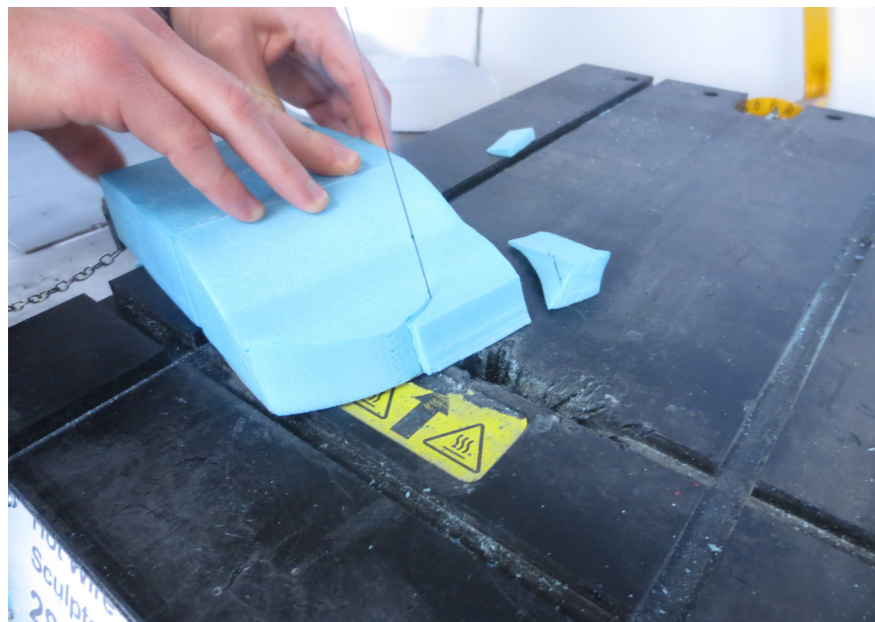

Steady curves were created with the pivot tool, and the wire was set to an angle to ensure adequate draft angles in the final mold. Once the general contours were removed, the body was sanded down, and the edges were rounded.

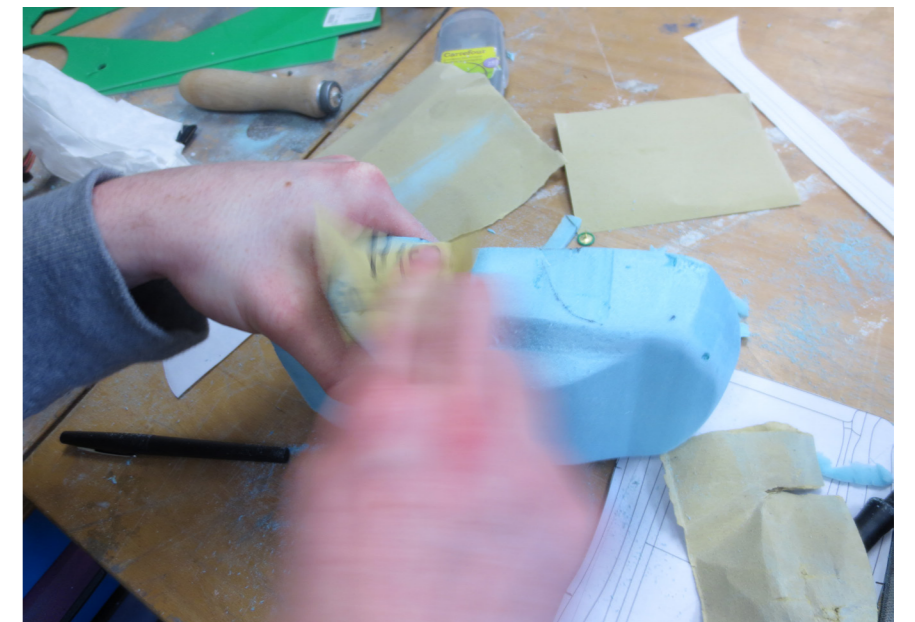

Prototype

We used the hand held scanner to scan our foam model of the body. The file we retained was then taken into FastScan and Cura, and edited to remove superfluous data points.

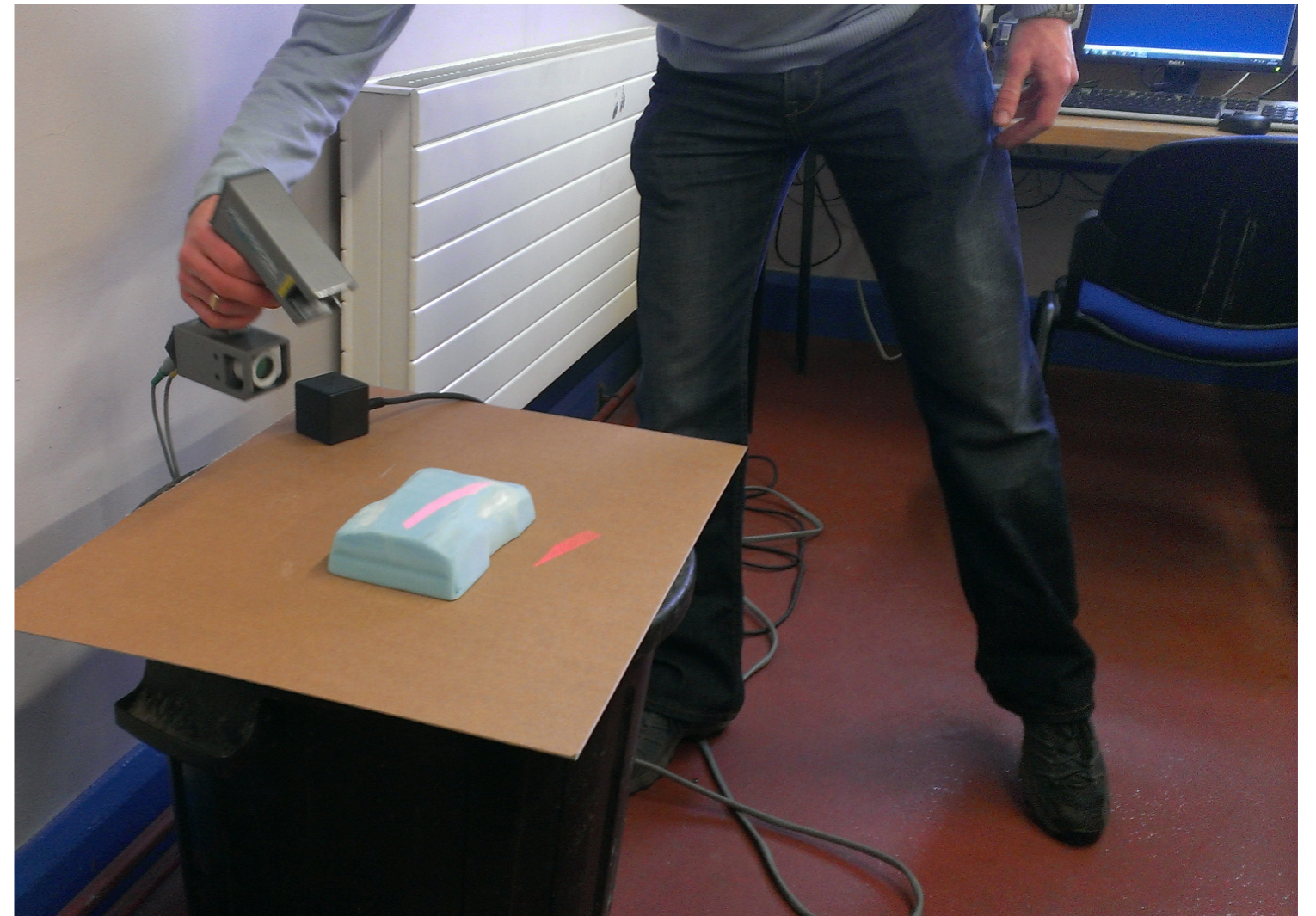
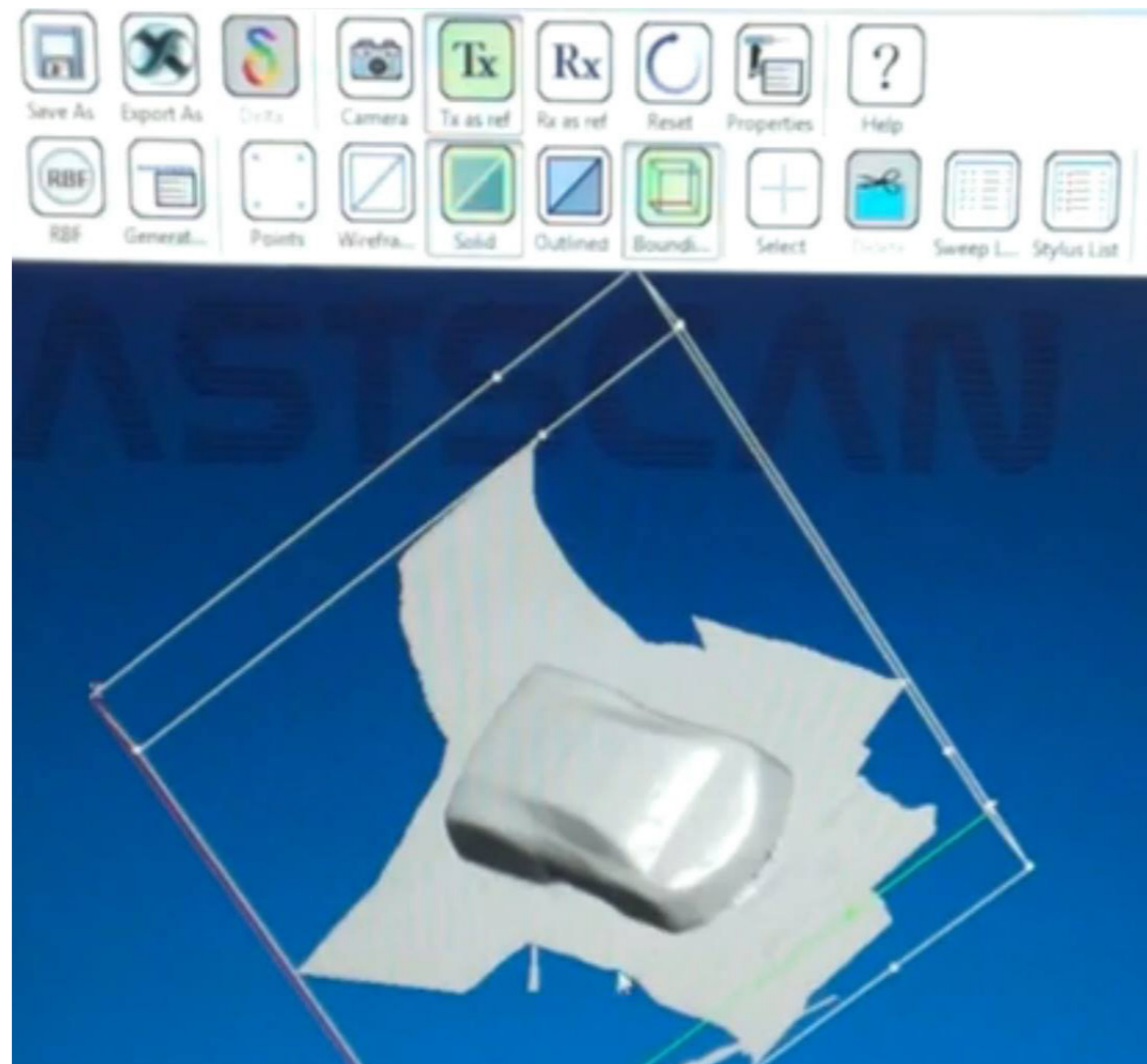

Prototype

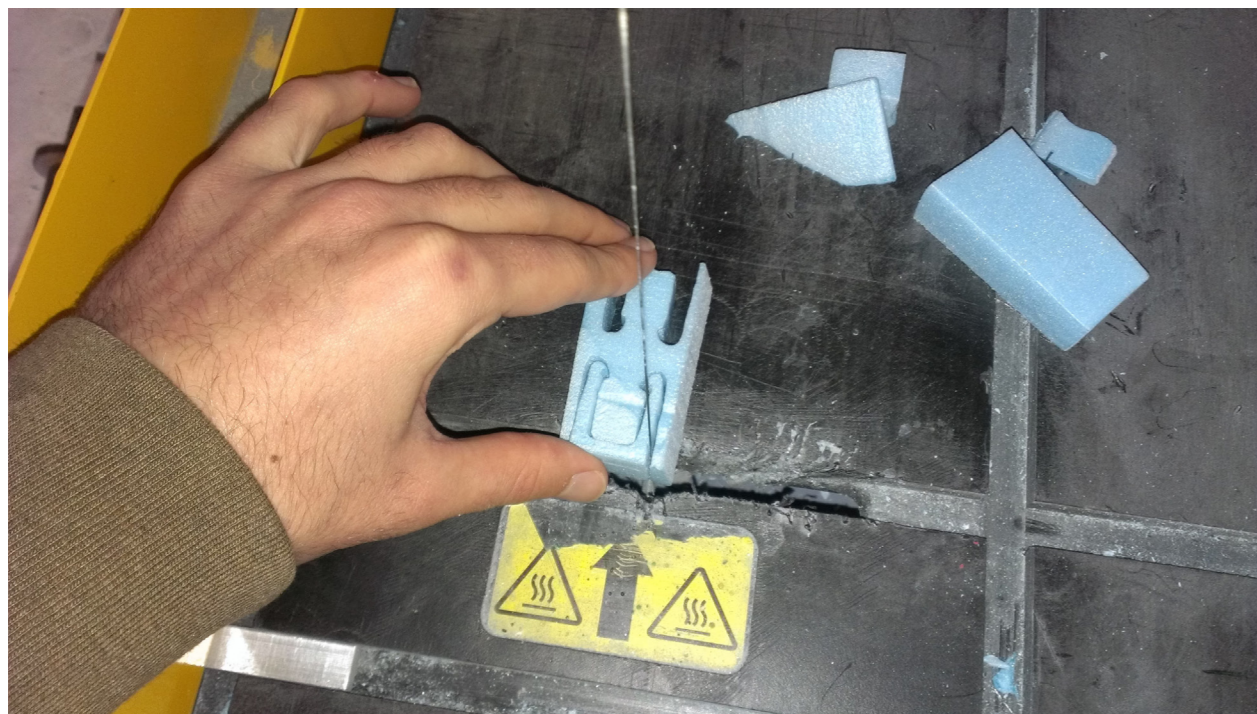

We made foam models of all our components to get an idea of the sizes of the parts and how they should be arranged on the chassis. When making the battery housing we noticed the batteries didn't fit with the mount. Luckily we noticed this problem with the foam model and were able to correct it before we made the actual part.

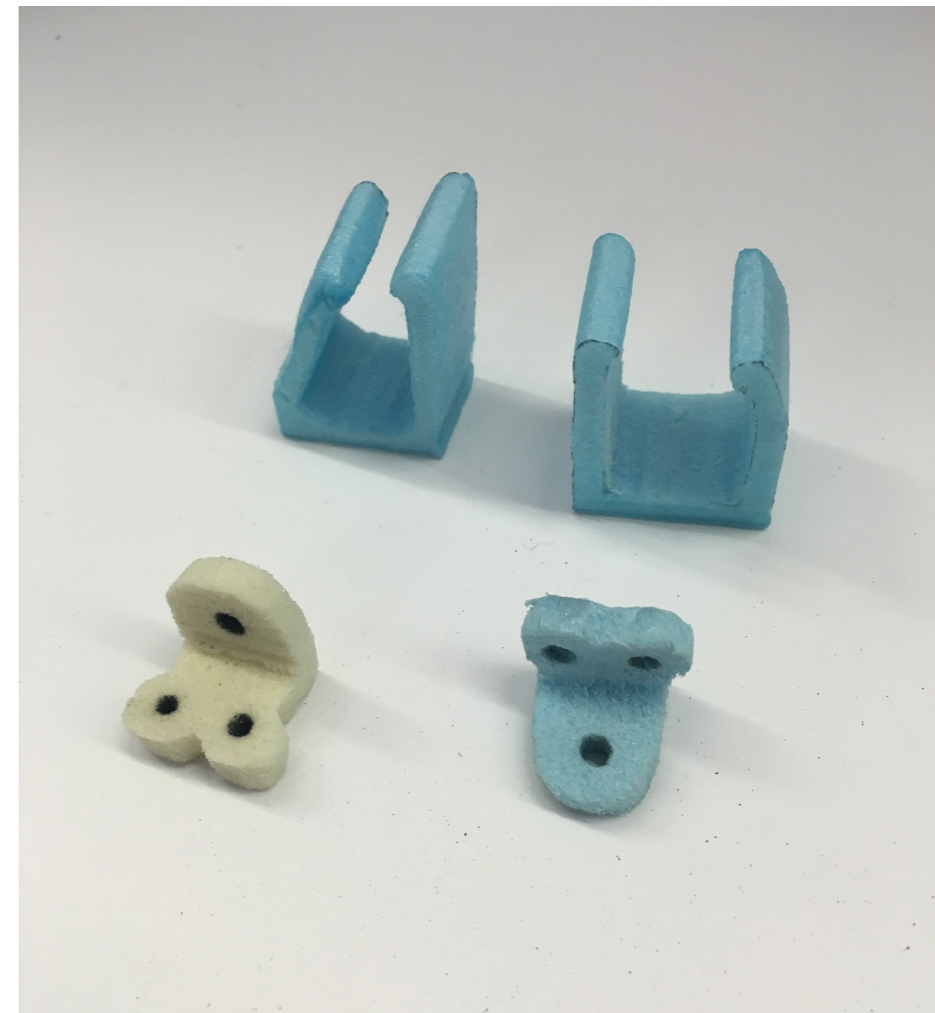

Prototype

We ended up using our original SolidWorks model to print our mold. We shelled the model to minimize the amount of material we used. We then uploaded the file to the powder printer to be printed. Once the mold was printed, we brushed off excess powder and sanded the surface. We then coated the outer surface of the mold with super glue to increase its strength. We used clay to fill the mold and keep it from collapsing under the pressure of the vacuum forming machine.

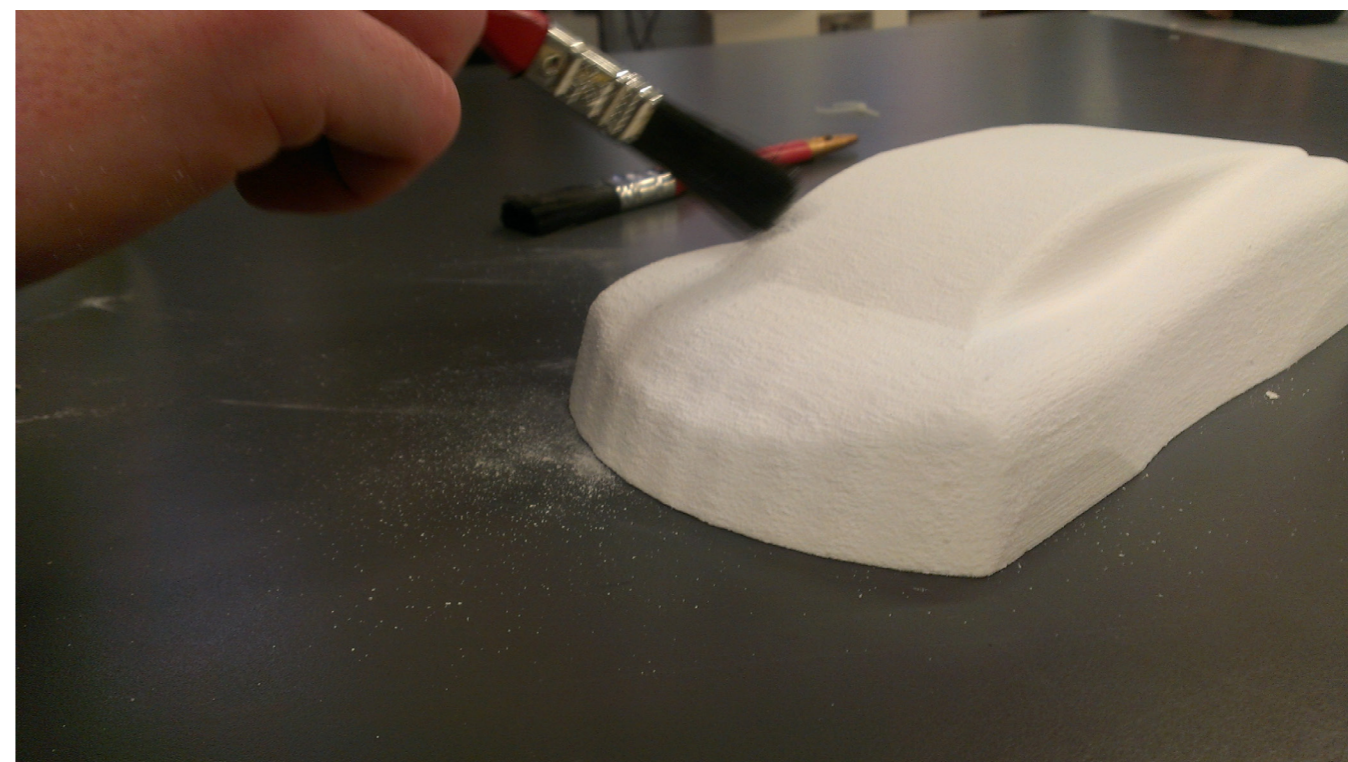

Prototype

Once the solidworks model had been shelled and powder printed, the resulting body was coated in super glue to reinforce the fragile shell. The cavity was then filled with clay, and it was placed in the vacuum former.

The powder body was easily removed before the plastic shell was trimmed and cleaned.



Prototype

Some final touch-up work is done to make all the components fit and operate smoothly. Holes in the body for the axles are turned in to channels to allow more simple assembly.

Small modifications are made to ensure the wheels function properly.



Prototype

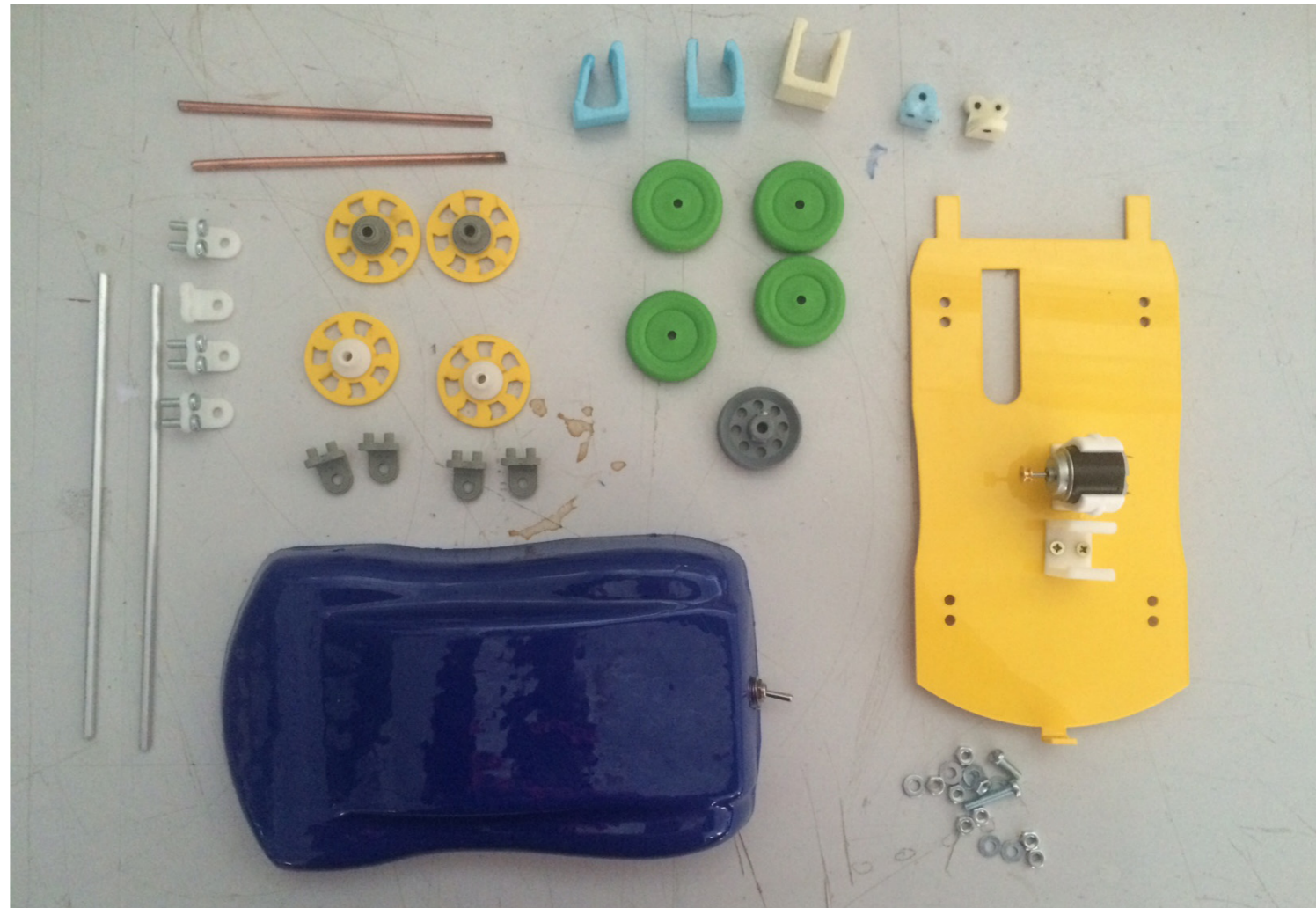

The selection of parts are spread out, old and new. The old wheels are cannibalized at the last minute to create stoppers, keeping the axles centered on the mounts.

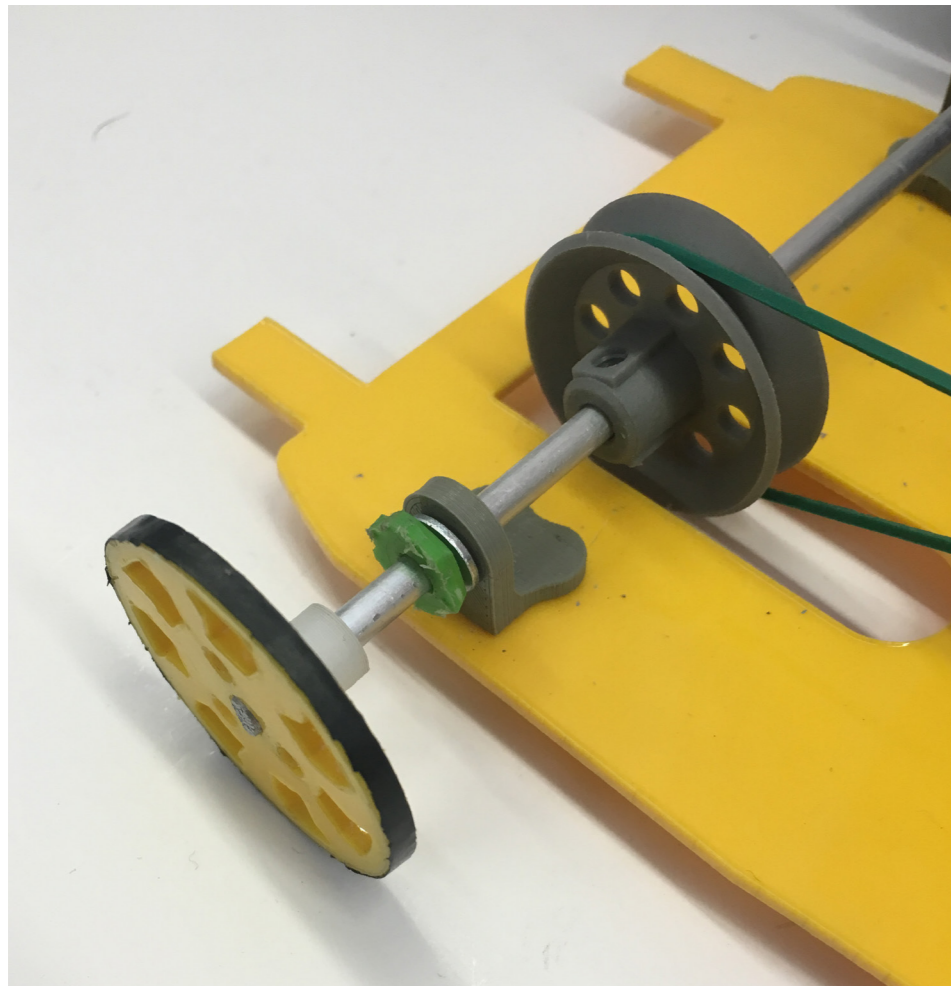

Finished Prototype



Finished Prototype

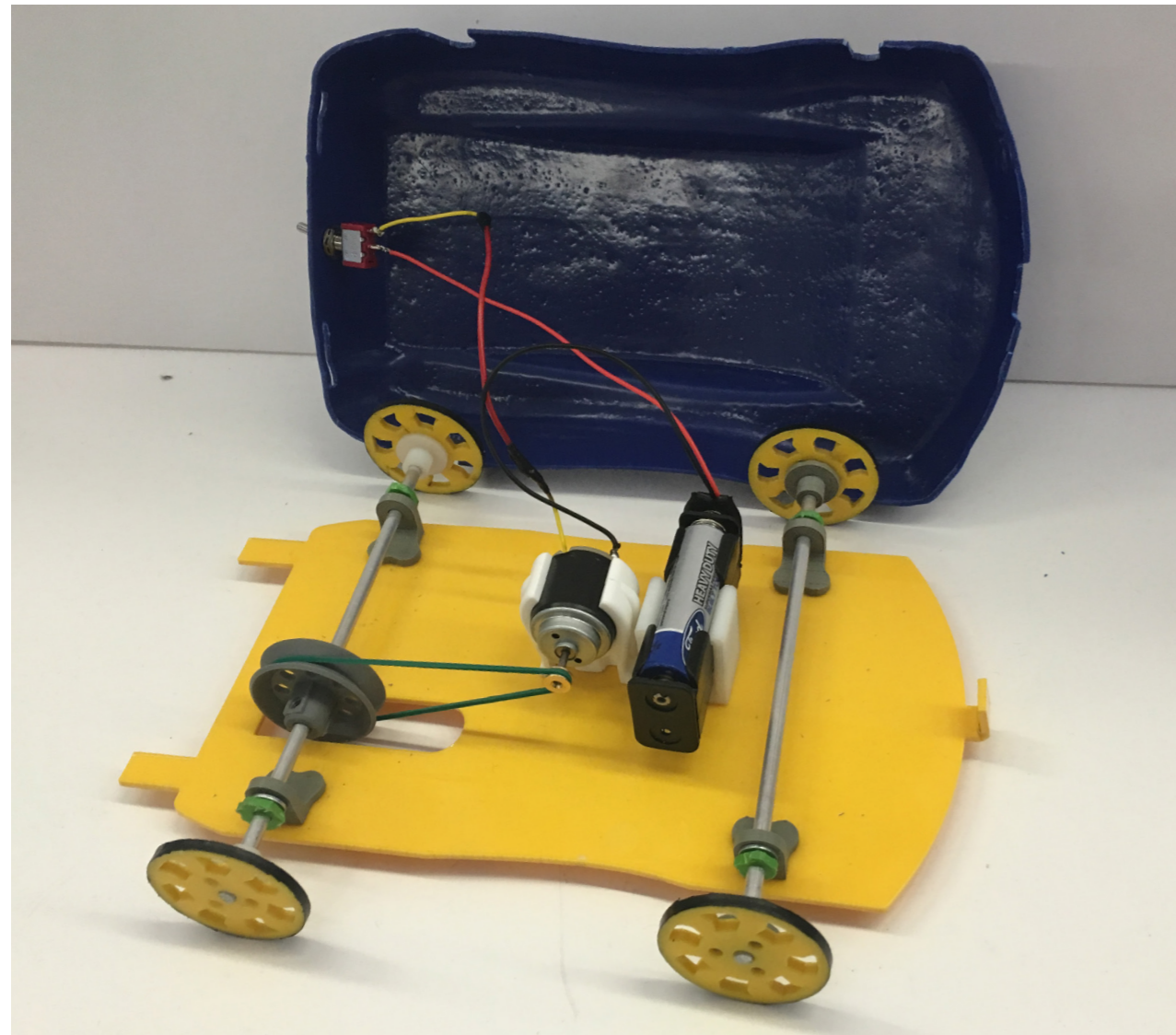

The cabin allows room for internal components. The electric motor was secured on the chassis at the tallest point on the body.

Barrel mounts fit snugly on the axle and lock into the laser-cut wheels. This keeps the wheels aligned.

We added black electrical tape to the bottom of the wheels to increase traction



Finished Prototype

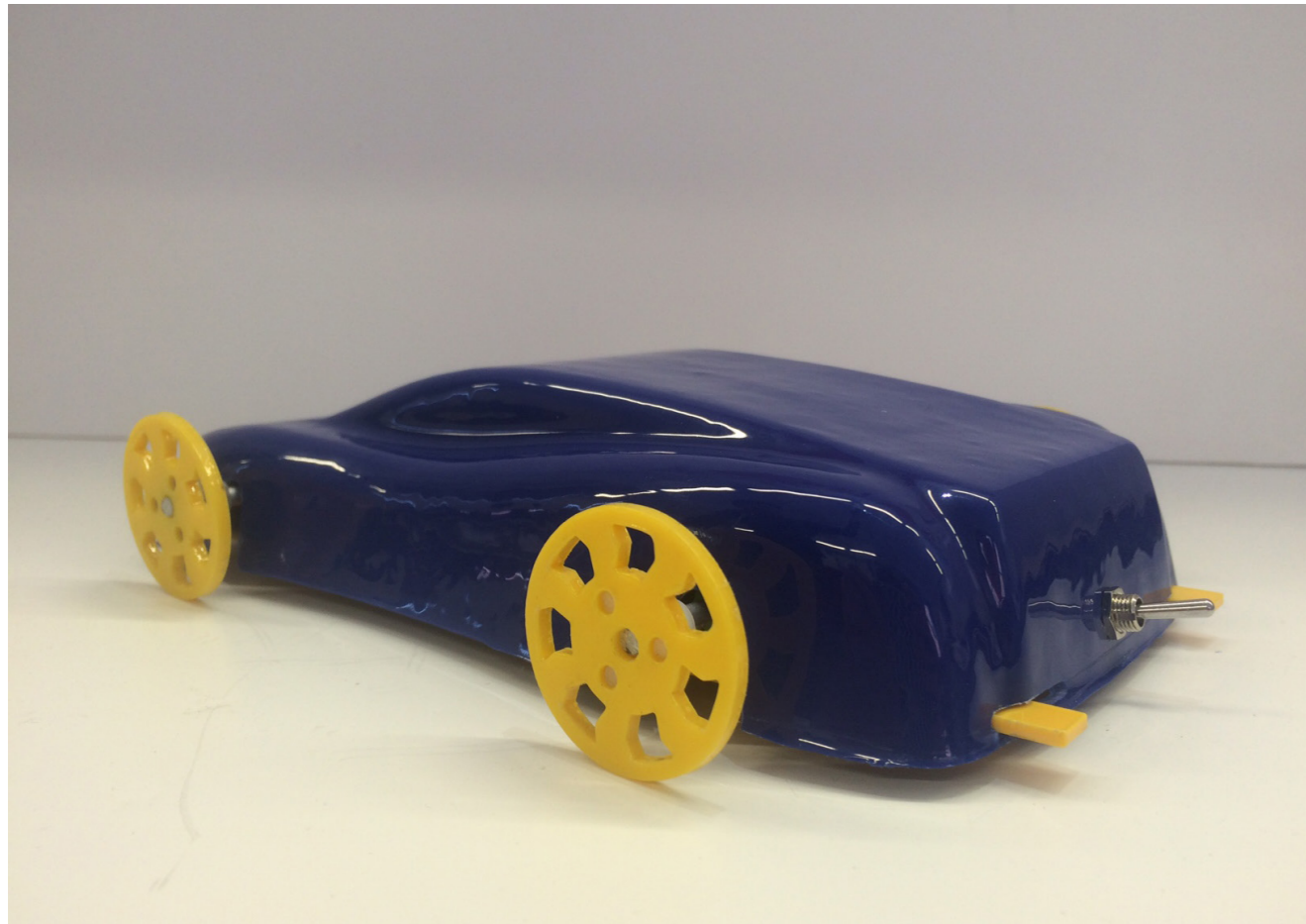

The body is held to the chassis with two forks which fits snugly in to corresponding slits.

The body sits very low to the ground, with bolts and mounts just barely clearing below the chassis.



Finished Prototype

The switch for the motor is mounted to the rear, so the forward movement is not impeded by the user.

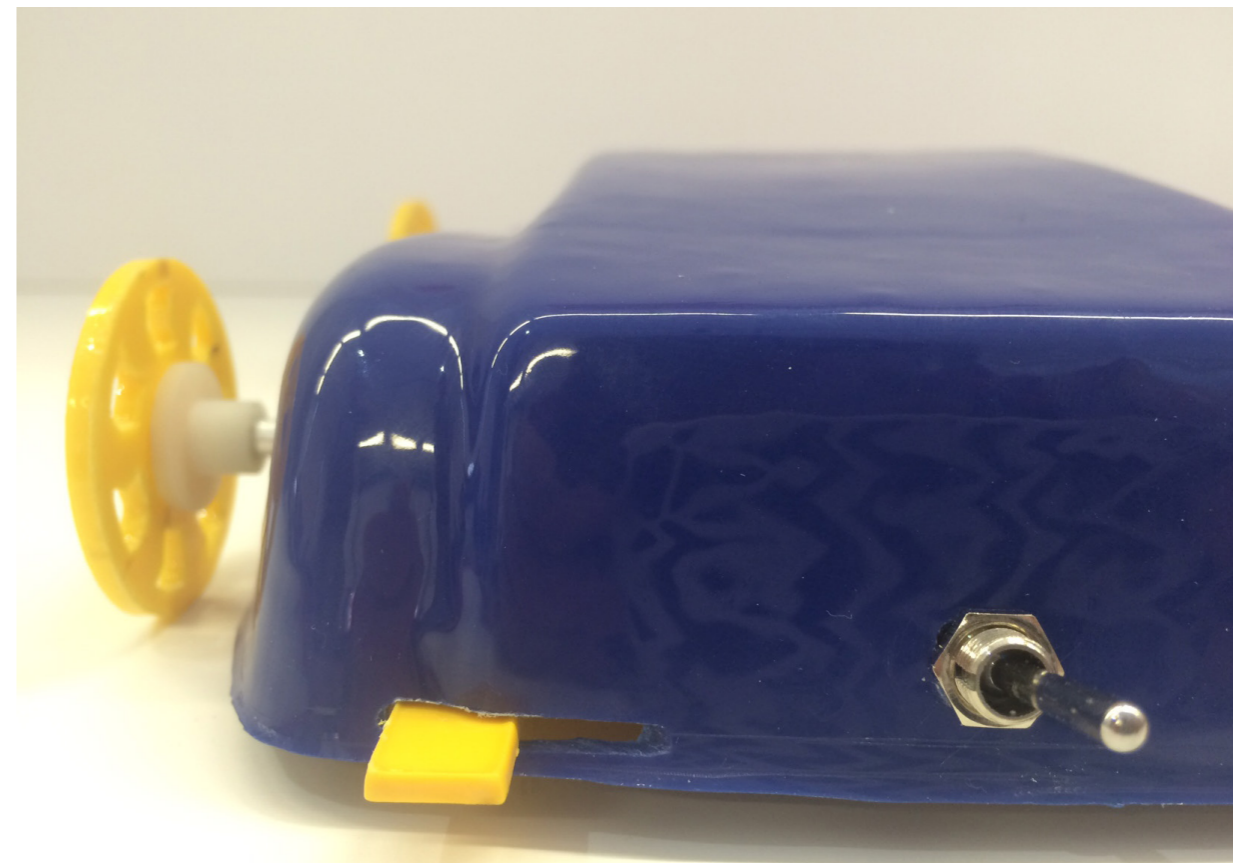
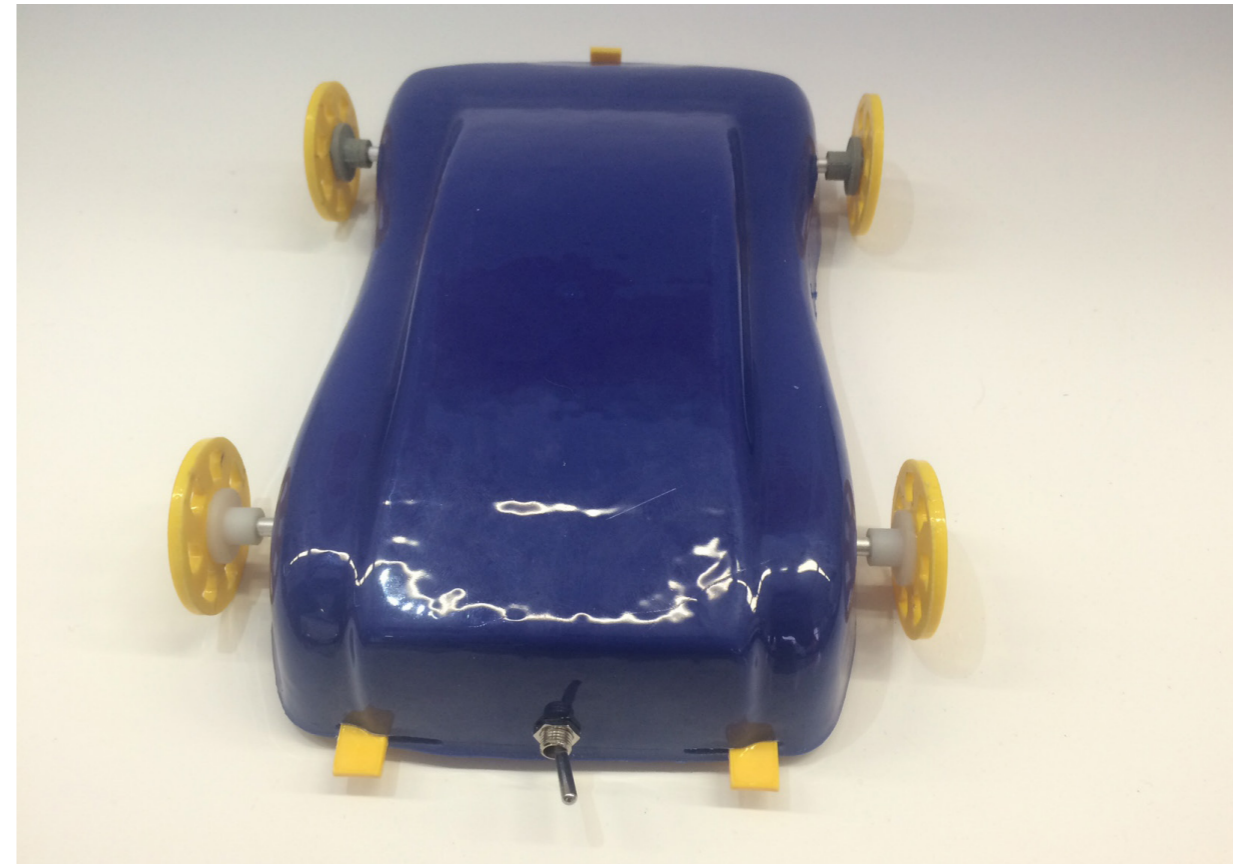
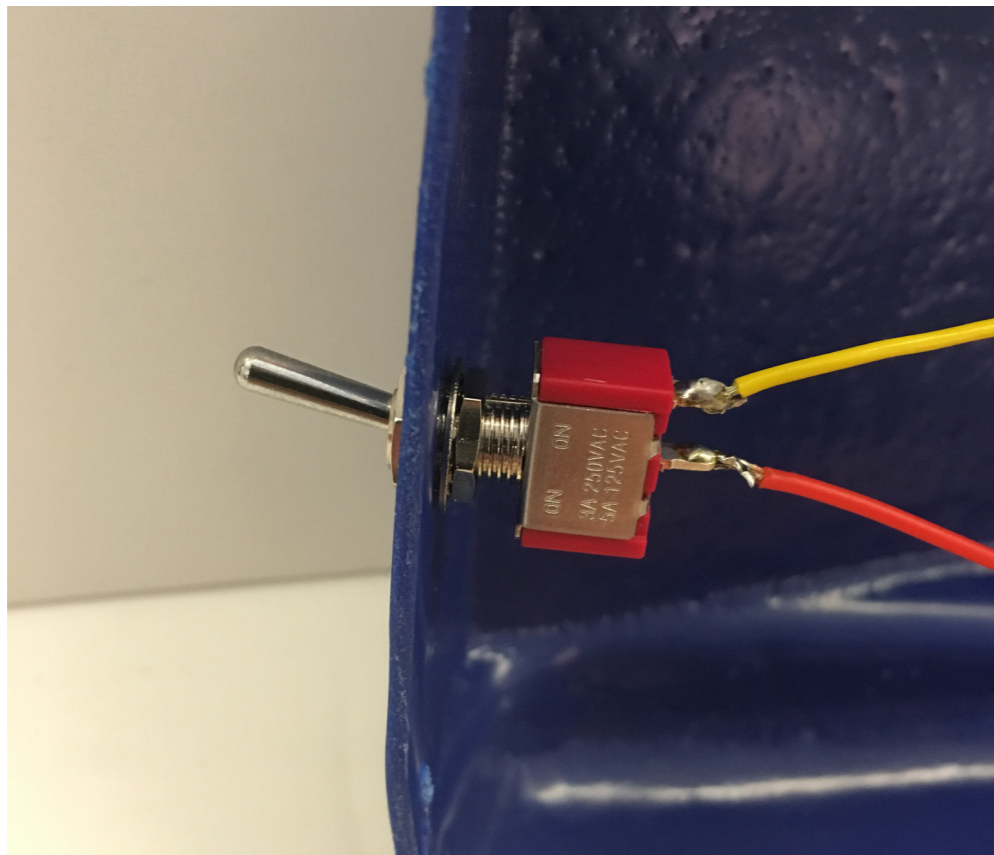

3.c BRIEFING TRABAJO DE INVESTIGACIÓN

DT001/2 - Rapid Product Development

Assignment 2: Prototyping Techniques - Project Brief and Schedule

This project carries 40% of the grade for the RPD module.

In this project, your team has been tasked with developing a coherent prototyping strategy for the company of which you are a part. Choose a company stating the company size, industries and markets in which it operates and the products developed.

You have been given four topics on which to base your work, one of which should be assigned to each team member. These topics are:

- 3D Printing (Encompassing the various technologies)
- Plastic Forming Processes (Vacuum Forming, Laser Cutting, Strip Bending, Joining Methods)
- 3D Scanning / Reverse Engineering (Contact Based Systems, Non-Contact Systems etc.)
- Short Run Moulding (Silicon Moulding, Reaction Injection Moulding, etc.)

For each of these processes, you will need to describe the following:

- History
- Current Technologies
- Future Trends
- Process characteristics, strengths and weaknesses
- Relevance to the company – e.g. which processes show most promise for incorporation into the company's product development plan, which technologies should be brought in-house or outsourced?

The author of the report on each topic should be clearly named at the beginning of each chapter.

A conclusion should follow the four chapters in which the main findings of the report are summarised by the team as a whole.

Schedule of Project Deliverables

- **Thursday, Week 10:** Brief Issued
- **Thursday, Week 14:** Presentation of your **final report**.
 - This report should be a bound document in A4 format and should employ the format provided in previous modules with respect to referencing, TOC, indices etc.
 - Any third party material which is not correctly referenced will leave the group at risk of a plagiarism investigation.

3.d TRABAJO DE INVESTIGACIÓN



Title: **Rapid Prototyping Report**

Description: **Manufacturing Methods**

Submitted by: **Jaume Luna, Daire Lonergan,
Callum Leneman**

Date Submitted: **12/05/2016**

Submitted for

Module: **Rapid Product Development**

Programme : **DT001-2, Product Design**

Lecturers: **Colm O'Kane**

Declaration

I certify that this submission is entirely my own work and has not been taken from the work of others, save and to the extent that such work has been cited and acknowledged within the text of my work.

Signature: _____

Date: _____

Signature: _____

Date: _____

Signature: _____

Date: _____

List of Figures

Figure 1 : Bio-Printed Tissues (Guardian, 2014)	1
Figure 2 : FDM Printing (Youtube, 2015)	2
Figure 3 : 3D Printing (Gajitz, 2014)	3
Figure 4 : LOM Printed Map (Sketchuaction, 2015)	3
Figure 5 : DLP Printing (Printr, 2016)	4
Figure 6 : Electron Micrograph of a Nanostructure (Forbes, 2016).....	5
Figure 7 : Custom Printed Lego Parts (Shapeways, 2014)	5
Figure 8 : Triangulation (RapidForm, 2014)	10
Figure 9 : Structured Light Scanner (RapidForm, 2014).....	11
Figure 10 : Laser Pulse Scanner (RapidForm, 2014).....	11
Figure 11 : Laser Phase Scanner (RapidForm, 2014).....	11
Figure 12 : 3D Scanner (3D, 2015)	12
Figure 13 : Tactile Scanner (Creaform3d, 2016)	13

1 Additive Manufacturing – Callum Leneman D15125002

1.1 History

Additive manufacturing, as it is known today, was pioneered by Hideo Kodama of the Nagoya Municipal Industrial Research Institute. In 1981, Nagoya published his research involving the production of a rudimentary three-dimensional model from the stacking of photopolymer layers (HowStuffWorks, 2016). This concept of building a 3D object by layering thin cross-sections is the foundation of current additive manufacturing techniques. This concept was pushed further by founder of 3D systems, Charles Hull at the Massachusetts Institute of Technology. In 1984, Hull is credited for inventing stereolithography; the process of exposing layers of photo-sensitive acrylic resin to UV light in order to cure it in to a hard object. In 1992, 3D systems created the first iteration of a Stereolithographic Apparatus (SLA), which applied the concept of stereolithography in a machine (LineShapeSpace, 2016). These novel methods were first applied in the field of rapid prototyping, to minimize the time needed to fabricate tangible, functioning prototypes.

By 1999, scientists at the Wake Forest Institute for Regenerative Medicine were able to print the skeleton of a human bladder, which they then covered in tissue cells from a patient in which the formed bladder would later be implanted. Because the patient donated the cells, the organ wouldn't be rejected by the immune system. Between that pivotal moment and 2009, many more bio-medical applications of 3D printing were explored, including the printing of a blood vessels in 2009, a functioning kidney in 2002, and even an articulating prosthetic leg in 2008 (Engineering, 2015).



Figure 1 : Bio-Printed Tissues (Guardian, 2014)

In 2006, selective laser sintering (SLS) machines were released commercially, making additive manufacturing available to private users for the first time. With this comes the beginning of so-called 'mass-customization', where individuals are capable of producing and modifying products from home. Private companies such as Shapeways also begin to appear around 2008, which offer customers affordably manufactured parts through an online service. In 2011, additive manufacturing technology is used to produce highly efficient parts for aircrafts and automobiles that would otherwise be cost-inefficient to produce.

Between 2010 and 2013, the price of a personal 3D printer dropped from nearly \$20,000, to less than \$1,000, and continues to become more available to the every-day user today.

1.2 Current Technologies

Since its genesis, 3D printing has made great strides and improvements, overcoming the limitations of its primitive infancy. The 3D printing process has become faster, cheaper, more detailed, and can be made of a greater variety of materials.

1.2.1 Fused Deposition Modelling (FDM)

FDM printers are the most common personal printers. This method builds objects by stacking layers of heated plastic filament on top of one another. First, virtual models are made of the part. Then software is used to cut the model into

slices that are appropriate for the fidelity of the FDM printer. Each slice will result in one layer of melted filament. The part is then digitally oriented in the machine to minimize printing time and material use.

The printer then heats thermoplastic filaments to a semi-liquid state, and extrudes the plastic on to a table. The table may be heated to increase the flatness of the bottom of the product. The extruding head then builds the object up one layer at a time. If there are areas that would require the extruder to leave a bead of plastic above an empty space, a support material will be built pre-emptively. This support material can be broken away, or made from a soluble plastic.

Once the object has finished being printed, it is allowed to cool, and removed from the table. Any support material is broken away or dissolved, and imperfections are cut or sanded off. The quality of the final object depends on the fidelity of the print. Higher resolution parts takes longer because the layers are thinner and the printing head has loner to travel. FDM printers can use a variety of filaments, as long as they are thermoplastics (Stratasys, 2015).

FDM printers generally have a lower resolution than alternative additive manufacturing methods due to the necessary thickness of the filament. Depending on the quality of the print, the part can be very strong.



Figure 2 : FDM Printing (Youtube, 2015)

1.2.2 3D Printing

Many additive manufacturing processes are referred to as 3D printing, however literal 3D printing involves layers of powder, selectively adhered with PVA glue. This process is nearly identical to ink printing, and even uses an ink cartridge and printing head to distribute the glue. Similar to FDM printing, virtual models are made of the part to be printed, and cut into slices. The printer houses two vats of powder, one which donates building material, and one in which the object will be built. As one lowers, the other rises, dusting powder onto the building area one layer at a time. The resulting body is removed from the building area, and the loose, un-glued powder is brushed off. In this state, the part is fragile and prone to crumbling until it is sealed with super glue.

This method of additive manufacturing has the potential to make high-resolution parts, however they are relatively weak compared to alternative manufacturing methods. Because the parts are being printed in a bed of powder, there is now need for additional support material, which minimizes the amount of wasted construction materials (Z-Corp, 2016). Multiple printing heads can be used, and the glue can be mixed with inks to produce coloured parts. Furthermore, multiple components can be printed individually, with colours distinct to each part.



Figure 3 : 3D Printing (Gajitz, 2014)

1.2.3 Laminated Object Manufacturing (LOM)

This additive manufacturing method operates using the same layering technique as the previous methods, however the layers are made from pre-formed sheets of material. Paper, for example, will be stacked one sheet at a time to build a part. Each layer that is added will be glued and cut along a computer-generated path with either a laser or a blade. The final block of paper must then be broken apart to reveal the part in the middle.

This method is a comparatively low-cost option because of the availability of the various sheet materials used in the process. The resulting part has many similar qualities to wood, and can therefore be finished in similar ways. Because there are no chemical reactions in LOM, parts can be relatively large (Anon., 2015). Depending on the adhesive used, the structural integrity of LOM parts can be compromised by various solvents.

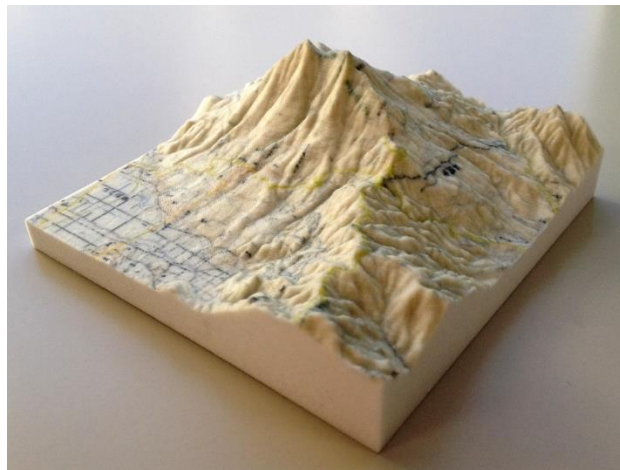

Figure 4 : LOM Printed Map (Sketchuaton, 2015)

1.2.4 Digital Light Processing (DLP)

DLP printing is a variety of Continuous Liquid Interface Polymerization (CLIP), in which parts are pulled out of a bath of resin. In the case of DLP, a photosensitive resin is selectively exposed to light, hardening layers of the liquid as the part is pulled away from the lens. Unlike other additive manufacturing processes, the DLP process is continuous, allowing for smoother parts (Industry, 2015).

DLP printed parts are extremely hard and stable. Because there are no discernible layers in the resulting object, fully transparent parts are achievable. Throughout the process, pieces under construction are supported by the bath they are made from, so there is no need for additional support material.

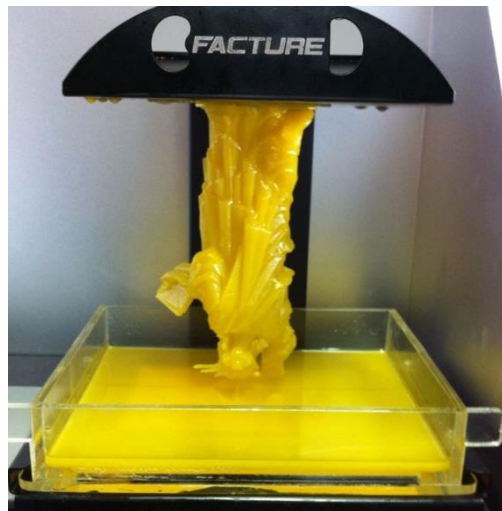

Figure 5 : DLP Printing (Printr, 2016)

1.3 Future Trends

By 2020, the field of 3D printing is expected to be a 8 ½ billion dollar industry, after growing by 14% per year (Print, 2016). In addition to improvements in speed, accuracy, cost, and material use, there are some foresights for the future of the additive manufacturing industry.

1.3.1 Transport

The versatility of additive manufacturing, and its ability to create objects that traditional injection moulding techniques would be incapable of producing makes it particularly interesting to the automotive and aerospace industries. By consolidating and combining functional parts into more complex components, planes, trains, and automobiles can become lighter and more efficient (PWC, 2016). Designers and manufacturers will be able to run through the iterative design process much more quickly with advanced rapid prototyping techniques. There is also now space for individuals and private companies to develop and produce replacement or aftermarket parts that are custom fit and have controllable properties.

1.3.2 Healthcare

The translation of existing scanning technology into complex tangible models has begun to make surgical procedures much more precise and comprehensible, and will continue to improve with the technology. The development of custom-designed orthopaedic appendages will result in enormous improvements to the ergonomics and functionality of prosthetics. Also, the continued expansion of bio-printed tissues and organs will revolutionize the field of healthcare.

1.3.3 Nano-Printing

3D printing on a microscopic scale has the potential to change the world, in areas such as bio-tech, electronics, and medicine. Batteries the size of a grain of rice and complex three dimensional circuit boards allow scientists and engineers to push the boundaries of nanotechnology (Forbes, 2016). The simplification of nanostructure manufacturing will make the evolution of nanotechnology much more economically viable.

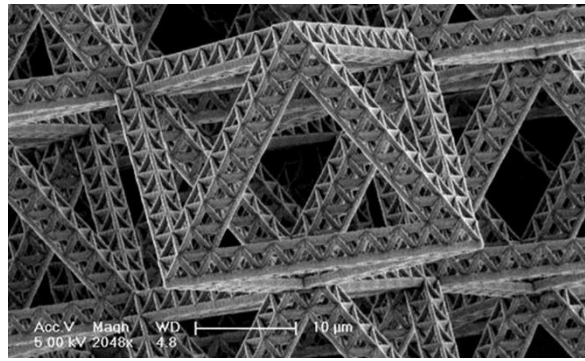

Figure 6 : Electron Micrograph of a Nanostructure (Forbes, 2016)

1.4 Application at Lego

1.4.1 Manufacturing

The relatively fast production times and potential variety of materials make 3D printing an ideal method of quick prototyping. New parts or product lines can be quickly modelled and mock-pieces can be produced without the expense of tooling in high-volume manufacturing.

1.4.2 Public Relations

Furthermore, Lego is currently investigating ways of including customizable 3D printed parts. Patent WO 2014005591 A1 involves technology that would allow personal consumers to print custom parts on pre-moulded Lego bases from home (Print, 2016). Lego customers have been FDM printing custom parts since the technology was available, and patenting plans and parts is the first step towards tackling the complex and ever-changing field of intellectual property protection with 3D printed parts.



Figure 7 : Custom Printed Lego Parts (Shapeways, 2014)

2 Plastic Forming – Daire Lonergan C14479238

2.1 Vacuum Forming

Vacuum forming is a very commonly used plastic forming technique. The process is quiet simple.

- Firstly a sheet of thermoplastic is heated until it become malleable.
- It is then lowered over a mould.
- The platform the mould sits on contains holes connected to a vacuum.
- The vacuum sucks all the air out, pulling the plastic tight to the mould.
- The plastic is then left to cool before being removed from the mould.

After WWII the former chief of the army map service, E.Bowman Stratton, Jr., started developing the vacuum forming machine. He wanted to be able to make 3 dimensional maps, and believed using sheet plastic would be the best way of achieving this (Dawes, 2015). Vacuums were already being used to remove air in plastic casting processes, and he saw how he could use a vacuum to pull a sheet of plastic over a mould.

The First vacuum forming machine was displayed at the 1952 SPI National Plastics Exhibition in Philadelphia, USA. The machine was an instant hit amongst the guests at the exhibition because of the inexpensive moulds (Dawes, 2015). This made producing plastic parts in small quantities much more viable, and thus sparked a massive increase in plastic production. In the beginning plastic forming machines were commonly used for displaying and marketing (Display Developments, n.d.).

Heating

Ceramic heaters are the most commonly used in modern vacuum forming machines. Ceramic heaters are desirable as they radiate long wavelength heat, which is easily absorbed by the plastic. (C.R Clark & Company, n.d.)

Quartz emitters are also used. They have a smaller thermal mass than ceramic heaters which allows them to heat up quicker, but the heats wavelengths are shorter. (C.R Clark & Company, n.d.)

For thicker sheets of plastic (*6mm+*) there may be heaters on both sides of the sheet, Instead of just on top. (C.R Clark & Company, n.d.)

Pressure forming

When vacuum forming, the pressure that can be applied to the plastic is limited by the atmospheric pressure. For certain applications this won't suffice. In this case the vacuum machine will also have a pressure chamber on top of the forming. This will help force the plastic into place. (C.R Clark & Company, n.d.)

Plug assisted forming

When forming with deep cavities, the plastic can become very thin. You cannot have a cavity deeper than half the diameter of the cavity with a normal sheet of plastic. When producing plastic cups and yogurt containers, they use a pre moulded plug to overcome the thinning effect caused by vacuum forming.

Vacuum forming uses low forming pressure enabling low cost tooling. The moulds can be made quicker and from cheaper materials than other forming processes, making it ideal for prototyping. The vacuum forming process can be completely automated, further reducing costs. Vacuum forming does require finishing, as the excess plastic needs to be trimmed off. (British Plastics Federation, n.d.)

LEGO would use vacuum moulding to make some of their packaging inserts. Vacuum moulding would be ideal for this because of its low cost, automation and high production volume.

2.2 Laser Cutting

A Laser (light amplification by stimulated emission of radiation) is a device that focuses light onto a specific point. With a high intensity lasers are capable of burning through materials.

Laser Cutting is a sheet forming process than can be used for an array of materials. It works by focussing a laser onto the sheet. The laser will fully cut or emboss the sheet. A path would be programmed into the machine for the laser to follow. After the cutting is complete the unwanted parts can be pushed out may be reused or recycled.

The first production laser machine was used to cut diamond dies in 1965. It had been produced by the Western Electric Engineering Research Centre (Bromberg, 1991). In the 1970s laser-assisted oxygen jet cutters were used to produce titanium parts for aerospace applications.

Semiconductor lasers are used for low power applications such as DVD and CD players.

Gas Lasers are used for medium power laser cutters

Solid state Lasers are the strongest and are used for cutting and welding metals (DIT, n.d.).

Laser cutters can be used to produce a surface finish as well as cut. Laser cutters can raster a sheet, which is burning little dots onto the surface to produce an image.

Lasers cutters can be used on many materials including

- Plastics
- Metals
- Woods
- Fabrics
- Leather
- Ceramics
- Paper/Card

Laser cutting is versatile in the types of materials and thicknesses that can be used. It is a fast, accurate and precise operation. There is usually no secondary processes necessary for laser cut parts, making it more efficient.

Laser cutters do use a lot of power, which is costly. The machines can be very expensive. Lasers can often burn the materials that they are cutting and cannot be used on reflective materials such as brass, copper or sometimes aluminium (Fab2order, 2015).

LEGO wouldn't use laser cutting for mass production of any of their products. However laser cutters could be used in the design development phases for their products. They could also use laser cutters for their signature LEGO statues that you see in their theme parks, LEGO Land.

2.3 Strip Bending

Strip bending is a plastic forming process that involves heating a straight 'strip' of a plastic part. The 'strip' part of the plastic becomes malleable allowing it to be bent.

Hot wire strip heaters work by sending a current though a resistive wire, causing it to heat up. The temperature can be controlled by changing the voltage. As long as he wire is in tension it will be perfectly straight. The plastic part is place near but not touching the wire, along the desired bending line. All thermoplastics can be used with hot wires. (CR Clarke & Co, n.d.)

Radiant Element or Inconel Sheathed Element Heaters can heat the plastic at different temperatures along the strip. These strip heating machines are suitable for plastics with a large elastic window. (CR Clarke & Co, n.d.)

Contact heating works by pressing a heated blade against the plastic. The blade is heated by integral heating elements. This bending process is effective with thinner plastics because of its accuracy. It's suitable for plastics with a large elastic window. (CR Clarke & Co, n.d.)

Strip bending is an inexpensive forming process as not much power is required. It can be fully automated. Plastics can get distorted while strip bending and large radius bends can be difficult. (CR Clarke & Co, n.d.)

LEGO wouldn't use strip bending in the production of their products. They could use it in design development, to make prototypes of new products.

2.4 Joining Methods

There are three different plastic joining methods.

Plastic parts can be mechanically fastened using hinge, latches or dents. This method only works with strong plastics as the joints have to survive the strain of assembly. This fastening method is effective for disassembly, and it can also join different types of plastic together. (Lee Spring, 2002)

Adhesives can be used to bond plastic parts together. There is usually surface preparation required and curing time, making it a slow process.

Plastics parts can be welded together. This gives a strong bond between the parts, but they need to be similar plastics. Plastic welding can only be done to thermoplastics and the parts cannot be disassembled.

LEGO would use plastic joining for some of its packaging. Some LEGO products come in plastic tubs with hinges on them. When LEGO 'master builders' are building their LEGO statues. They completely construct the statue first, disassemble it and then reassemble using super glue. This is stop it from being taken apart by kids.

3 Reverse Engineering – Jaume Luna Alapont D15126904

3.1 Definition

Reverse engineering is a process of measuring, analysing, and testing to reconstruct the mirror image of an object or retrieve a past event. It's a technology of reconstruction, reproduction and reinvention. It is also the art of applied science for preservation of the design intent of the original part (Wang, 2012).

Reverse engineering can be applied to re-create either the high value commercial parts for business profits or the valueless legacy parts for historical restoration. To accomplish this task, the engineer needs an understanding of the functionality of the original part and the skills to replicate its characteristic details.

Though it roots back to ancient times in history, the recent advancement in reverse engineering has elevated this technology to one of the primary methodologies utilized in many industries.

3.2 History

The impact of reverse engineering on today's industry is beyond just introducing less expensive products and stimulating more competition. It also plays a significant role in promoting industrial evolution. The life cycle of a new invention usually lasted for centuries in ancient times, however, the average life cycle of modern inventions is much shorter.

To accommodate this rapid rate of reinvention of modern machinery and instruments, reverse engineering provides a high tech tool to speed up the reinvention process for future industrial evolution. Reverse engineering plays a significant role in the aviation industry primarily because of the following reasons: maturity of the industry, advancement of modern technologies, and market demands. From the dawn of the aviation industry in the early 1900s to its hardware maturity with the development of jet aircraft in the 1950s, the aviation industry revolutionized the modes of transportation in about 50 years (Wang, 2012).

3.3 Applications in Design

Reverse engineering is a multidisciplinary generic science and virtually can be applied to every field universally. The primary applications of reverse engineering are either to recreate a mirror image of the original part, decode the mechanism of a function, or retrace the events of what happened. It is widely used in software and information technology industries, from software code development to Internet network security. It is also used to reconstruct the events just before and immediately after accidents in the aviation, automobile, and other transportation industries. Forensic science is another area where reverse engineering is used to help resolve the myth. Other fields, such as medical systems, architecture and civil engineering, shipbuilding, and art galleries, also find a lot of reverse engineering applications.

For the designers reverse engineering it's used in prototype production for new design and repairs for used parts as well. Thousands of parts are reinvented every year using reverse engineering to satisfy the aftermarket demands that worth billions of dollars.

Prototyping is often referred to as rapid prototyping to reflect one of the most distinctive features of this technology: much faster production of a tangible model part compared to traditional machining and other manufacturing processes. Prototyping revolutionizes the model part creation in machine design and reverse engineering, and provides designers with a tool to quickly convert a conceptual design idea into a physical model part. It helps engineers to visualize the design drawing and computer modelling (Fernandes, 2007).

Automation with modern digital technology is the primary advantage of prototyping, which subsequently leads to other benefits, such as the aforementioned speedy production, cost savings, easy operation, and free manufacturing of complex geometric design. Therefore, rapid prototyping is from time to time referred to as rapid manufacturing or direct digital manufacturing, depending on its applications. However, the current rapid prototyping methods featured with modern high technologies are still subject to some limitations that are critical to reverse engineering, such as part accuracy, material restrictions, and surface finishing. An additive prototyping process incrementally adds layers of ceramic, wax, or plastic one atop another to create a solid part, while a subtractive prototyping process such as milling or drilling removes material to shape up the part. It is very beneficial and sometimes essential in reverse engineering to first produce a few model parts from the collected

data before entering the production phase. Prototyping can quickly produce a model part at reasonable costs for form, fit, and functional test during the reverse engineering process.

3.4 Process

In recent years the part geometric form has been very accurately measured and replicated by the advanced technology of metrology. The precision hardware and sophisticated software allow engineers to visualize, meter, and analyse the part geometric details. They also allow the transformation of ray data to be intelligently reconstructed into computer mode. The revolutionary advancement in software algorithm and hardware infrastructure offers a set of new tools for rapid prototype in reverse engineering. All the miniature geometrical details of a part can be captured and retained. The development and deployment of the interchangeable operating systems and data transformability further accelerate today, reverse engineering capability metric form analysis and reproduction. These new technologies have a huge impact on modern reverse engineering and have been deployed in this field.

3.5 Current Technologies

As mentioned before designers use reverse engineering in their prototyping process, and now some of the technologies available are being explained.

Lasers, lights or x-rays and generates dense point clouds or polygon meshes can be considered a 3D scanner. They go by many names, including 3D digitizers, laser scanners, white light scanners, industrial CT, LIDAR, and others. The common uniting factor of all these devices is that they capture the geometry of physical objects with hundreds of thousands or millions of measurements.

And the current 3D laser scanner technologies are:

- Laser Triangulation 3D Scanners

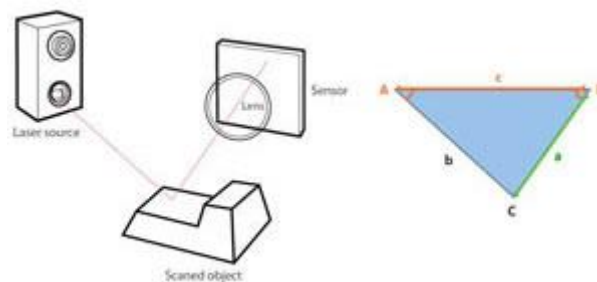

Figure 8 : Triangulation (RapidForm, 2014)

Laser triangulation scanners use either a laser line or single laser point to scan across an object. A sensor picks up the laser light that is reflected off the object, and using trigonometric triangulation, the system calculates the distance from the object to the scanner.

The distance between the laser source and the sensor is known very precisely, as well as the angle between the laser and the sensor. As the laser light reflects off the scanned object, the system can discern what angle it is returning to the sensor at, and therefore the distance from the laser source to the object's surface.

- Structured Light (White or Blue Light) 3D Scanners

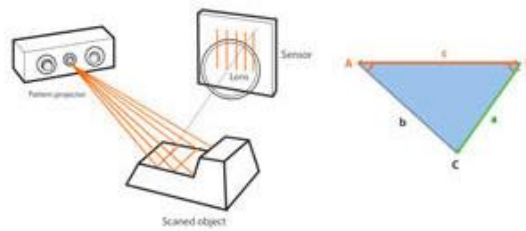

Figure 9 : Structured Light Scanner (RapidForm, 2014)

Structured light scanners also use trigonometric triangulation, but instead of looking at laser light, these systems project a series of linear patterns onto an object. Then, by examining the edges of each line in the pattern, they calculate the distance from the scanner to the object’s surface. Essentially, instead of the camera seeing a laser line, it sees the edge of the projected pattern, and calculates the distance similarly.

- Laser Pulse-based 3D Scanners

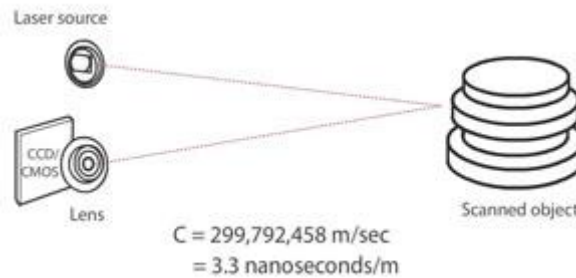

Figure 10 : Laser Pulse Scanner (RapidForm, 2014)

Laser pulse-based scanners, also known as time-of-flight scanners, are based on a very simple concept: the speed of light is known very precisely, so if we know how long a laser takes to reach an object and reflect back to a sensor, we know how far away that object is. These systems use circuitry that is accurate to picoseconds to measure the time it takes for millions of pulses of the laser to return to the sensor, and calculates a distance. By rotating the laser and sensor (usually via a mirror), the scanner can scan up to a full 360 degrees around itself.

- Laser Phase-shift 3D Scanners

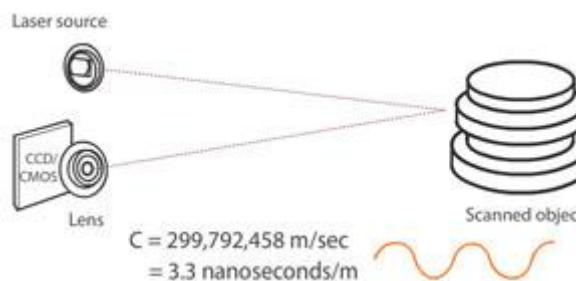





Figure 11 : Laser Phase Scanner (RapidForm, 2014)

Laser phase-shift systems are another type of time-of-flight 3D scanner technology, and conceptually work similarly to pulse-based systems. In addition to pulsing the laser, these systems also modulate the power of the laser beam, and

the scanner compares the phase of the laser being sent out and then returned to the sensor. For reasons that are beyond this web page’s scope, phase shift measurement is more precise.



FEATURES TECH SPECS USE CASES ACTIVATE DOWNLOADS [Buy Now](#)

-  The Sense 3D scanner delivers best-in-class accuracy of close to 1 mm with resolution at 1 mm.
-  Sense has an unprecedented color resolution of 1920 x 1080 pixels for perfect color texture mapping.
-  Sense has a generous scan range of between 7 and 72 inches to allow for rapid 3D scanning of a wide range of objects.
-  The Sense 3D scanner includes software to rapidly edit your 3D scan data and solidify for immediate 3D printing.
-  Save data out to four industry-standard formats for downstream uses.

SENSE 3D SCANNER TECH SPECS

<p>Supported operating systems Windows 8 or later</p>	<p>Scan volume ⓘ Min: 0.2m x 0.2m x 0.2m Max: 2m x 2m x 2m</p>	<p>Dimensions ⓘ 5.08(w) x 7.08(h) x 1.3(d) inches 12.9(w) x 17.8(h) x 3.3(d) cm</p>
<p>Operating range ⓘ Min: 0.2m Max: 1.6m</p>	<p>Depth image size ⓘ 640(w) x 480(h) px</p>	<p>Color image size 1920(w) x 1080(h) px</p>
<p>Field of view ⓘ Horizontal: 45° Vertical: 57.5° Diagonal: 69°</p>	<p>Spatial x/y resolution @ 0.5m 0.9mm</p>	<p>Depth resolution @ 0.5m ⓘ 1mm</p>
<p>Operating temperature 10-40° C</p>	<p>Data interface USB 3.0</p>	<p>USB cord length ⓘ 6 feet</p>
<p>Maximal image throughput ⓘ 30 fps</p>	<p>Hardware recommendations Intel® Core i5™ or equivalent processor RAM: 2 GB minimum 1280 x 1024 minimum screen resolution 4 GB available hard disk space</p>	<p>Warranty 1 year</p>

Figure 12 : 3D Scanner (3D, 2015)

Captures three-dimensional objects of less than 2 meters and translates that into a CAD file, also getting the colour of the object.

They're products are destined not only for designers and mechanical pieces manufacturing companies, also include easy controls that make the product available to use for regular non-professional users. That's because the scanning 3D scanning and printing technologies are a trend in the moment that even though the high price characteristic of these professional equipment, the products are arriving to a big non-professional customer.

- GOM touch prob



Figure 13 : Tactile Scanner (Creaform3d, 2016)

This touch probe enables 3D discrete point for direct comparison to CAD for difficult to access areas, hidden cavities, discrete points and primitives. Touch probe data can also be utilized for online data alignment. For non-standard applications, customized probe tips and adapters are available. Not only because of that is better than laser scanning, also can measurement of small to large objects.

But the main purpose of these procedure is to scan mechanical pieces which have geometrical forms, in the case of an organic or curved object a laser scan would be faster and more precise.

Example of reverse engineering in design prototyping process:



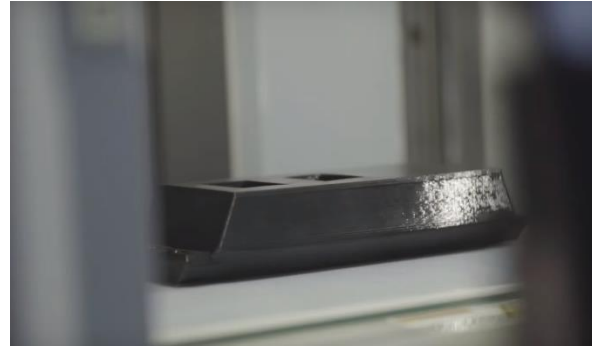
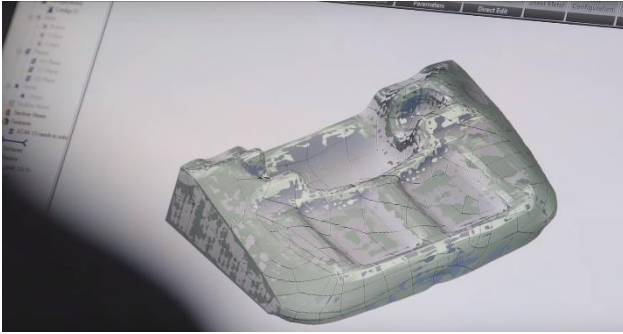

3.6 Application at LEGO

The company chosen LEGO would use reverse engineering in two ways because of the two different toy pieces that they manufacture.

For the geometrical and exact pieces they need these tools for design verification and for further redesigns saving money in new testing moulds for pieces. In these case touch probe technology would suit the accuracy level required.

An in the other hand they have organic pieces that need to have a mould so laser scanning which is very useful for curved and organic surfaces would be a good tool to make the CAD and moulding shorter and easier.

Summary and Conclusions

Modern technological advancements have revolutionized the way products are made. Designers are able to make functioning prototypes in a fraction of the time

The use of plastics in the fabrication of parts has revolutionized the manufacturing industry. Plastic materials offer an incredibly broad variety of properties, including strength, ductility, rigidity, colour and more, making plastic parts versatile and unique. Additive manufacturing techniques enable individuals and companies to build accurate, complex, and durable tangible objects in a matter of hours, allowing for physical investigation of models, and speeding up the iterative design process.

The methods of moulding, forming, cutting, and shaping parts are diverse and still evolving, leading to increasingly precise and complex objects.

Bibliography

3D, C., 2015. *Capture3D*. [Online]

Available at: <http://www.capture3d.com/3d-metrology-solutions/3d-scanners/gom-touch-probe.html>

[Accessed 6 May 2016].

3dPrint, 2014. *3dprint.com*. [Online]

Available at: <https://3dprint.com/1383/lego-awarded-3d-printing-patents-may-allow-users-to-print-own-bricks/>

[Accessed 9 May 2016].

Anon., 2015. *web.archive.org*. [Online]

Available at: <https://web.archive.org/web/20100102182152/http://home.att.net/~castleisland/lom.htm>

[Accessed 11 May 2016].

British Plastics Federation, n.d. *Vacume forming*. [Online]

Available at: http://www.bpf.co.uk/plastipedia/processes/vacuum_forming.aspx

Bromberg, J., 1991. *The Laser in America*. MIT press, p. 202.

C.R Clark & Company, n.d. *Introduction to thermoforming - vacume forming*.

CR Clarke & Co, n.d. *Local Line bending*. s.l.:s.n.

Creaform3d, 2016. *Creaform3d*. [Online]

Available at: <http://www.creaform3d.com/en/metrology-solutions/portable-3d-scanner-handyscan-3d>

[Accessed 2 May 2016].

Dawes, H., 2015. *1950s dawn of the comertial thermofoarming business*. [Online]

Available at: <http://www.plastimach.com/pmblog/thermoformers/1950s-dawn-of-the-commercial-thermoforming-business/>

Display Developments, n.d. *Vacume forming history*. [Online]

Available at: <http://www.displaydevelopments.co.uk/vacuum-forming-history-i-133.html>

DIT, n.d. *Laser Cutting and Forming*, s.l.: s.n.

Engineering, 2015. *Engineering*. [Online]

Available at: <http://www.engineering.com/3DPrinting/3DPrintingArticles/ArticleID/6262/Infographic-The-History-of-3D-Printing.aspx>

[Accessed 11 May 2016].

Fab2order, 2015. *Advantages/Disadvantages*. [Online]

Available at: <http://www.fab2order.com/advantages-and-disadvantages-of-laser-cutting/>

Fernandes, V. R. a. K. J., 2007. *Reverse engineering: an industrial perspective*. s.l.:s.n.

Forbes, 2016. *Forbes Magazine*. [Online]

Available at: <http://www.forbes.com/sites/ricksmith/2015/07/07/5-incredible-trends-that-will-shape-our-3d-printed-future/#28e8e936707f>

[Accessed 11 May 2016].

Forbes, 2016. *Forbes.com*. [Online]

Available at: <http://www.forbes.com/sites/ricksmith/2015/07/07/5-incredible-trends-that-will-shape-our-3d-printed-future/#28e8e936707f>

[Accessed 11 May 2016].

Gajitz, 2014. *Gajitz*. [Online]

Available at: <http://gajitz.com/pod-parts-3d-replicators-are-here-so-is-future/>

[Accessed 11 May 2016].

Guardian, 2014. *The Guardian*. [Online]

Available at: <http://guardianlv.com/2014/04/vaginas-engineered-in-laboratory-and-successfully-implanted/>

[Accessed 10 May 2016].

HowStuffWorks, 2016. *How Stuff Works*. [Online]

Available at: <http://computer.howstuffworks.com/3-d-printing1.htm>

[Accessed 8 May 2016].

Industry, 3. p., 2015. *3D printing Industry*. [Online]

Available at: <http://3dprintingindustry.com/3d-printing-basics-free-beginners-guide/processes/>

[Accessed 11 May 2016].

Lee Spring, 2002. *Machine design*. [Online]

Available at: <http://machinedesign.com/fasteners/joining-plastic>

LineShapeSpace, 2016. *LineShapeSpace*. [Online]

Available at: <https://lineshapespace.com/history-of-3d-printing/>

[Accessed 1 May 2016].

Print, 3., 2016. *3dPrint.com*. [Online]

Available at: <https://3dprint.com/54120/3d-printing-future-2/>

[Accessed 10 May 2016].

Printr, 3., 2016. *3DPrintr.com*. [Online]

Available at: <https://www.3printr.com/draken-new-dlpsla-3d-printer-kickstarter-2827037/>

[Accessed 11 May 2016].

PWC, 2016. *pwc.com*. [Online]

Available at: <http://www.pwc.com/us/en/technology-forecast/2014/3d-printing/features/future-3d-printing.html>

[Accessed 10 May 2016].

RapidForm, 2014. *RapidForm*. [Online]

Available at: <http://www.rapidform.com/3d-scanners/>

[Accessed 9 May 2016].

RedOrbit, 2016. *Redorbit.com*. [Online]

Available at: <http://www.redorbit.com/reference/the-history-of-3d-printing/>

[Accessed 8 May 2016].

Shapeways, 2014. *Shapeways*. [Online]

Available at: <https://www.shapeways.com/blog/archives/2021-a-mutant-minifigure-walks-out-of-shapeways-3d-printer.html>

[Accessed 11 May 2016].

Sketchuaction, 2015. *Sketchuaction.com*. [Online]

Available at: <http://sketchuaction.com/forums/viewtopic.php?f=388&t=55904&start=90>

[Accessed 11 May 2016].

Smithsonian, 2015. *SmithsonianMag.com*. [Online]

Available at: <http://www.smithsonianmag.com/science-nature/what-lies-ahead-for-3-d-printing->

[37498558/?no-ist=&fb_locale=en_GB&page=5](https://www.stratasys.com/3d-printers/technologies/fdm-technology)

[Accessed 9 May 2016].

Stratasys, 2015. *Stratasys*. [Online]

Available at: <http://www.stratasys.com/3d-printers/technologies/fdm-technology>

[Accessed 10 May 2016].

Wang, W., 2012. *Reverse engineering: technology of reinvention*. s.l.:s.n.

Youtube, 2015. *Youtube*. [Online]

Available at: <https://www.youtube.com/watch?v=vDKToHF9a4>

[Accessed 11 May 2016].

Z-Corp, 2016. *3dsystems*. [Online]

Available at: <http://www.3dsystems.com/about-us>

[Accessed 7 May 2016].

4. DESIGN ANALYSIS

En esta asignatura se estudian análisis físicos y de resistencia de objetos mediante el software informático Solidworks.

Y se emplea una metodología concreta para realizar informes físicos de productos que permite abordar todos los aspectos necesarios que una empresa podrá demandar de un diseñador industrial en un informe físico. Esta metodología se aplica al proyecto realizado.

4.a EJERCICIOS REALIZADOS

Class Exercise W05 Ex1 – Bone Wrench

Analysis Brief

The torque required to open a nut on a bike has been measured at 11.25 N.m. You are required to perform a design check on the handle area of a new wrench.

The area in Yellow makes contact with the nut, the force used to generate the torque is applied on the flat face of the other sphere.

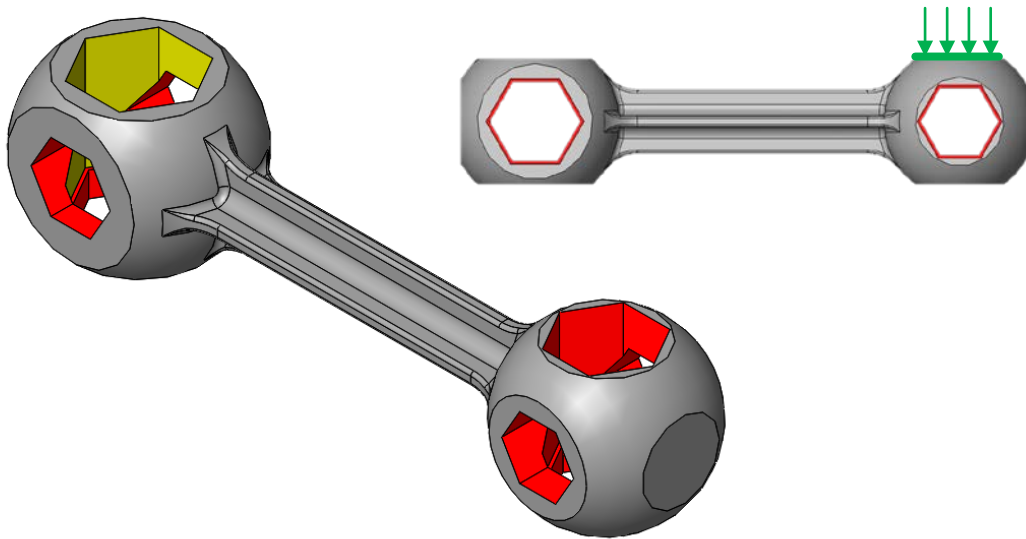

1. The planned material for the part is an Alloy Steel; $E = 210 \text{ GPa}$, Poisson's Ratio = 0.28, with a Yield Stress of approximately 724 MPa will this be sufficient for the part?

Yes/No _____

2. Focus groups have shown that a deflection of over 3mm can be felt by the user and has a negative effect on the perception of the product. Would the product pass this test?

Yes/No _____

Are any changes required to the part to meet the first two tests?

Draw a Free-body diagram for the body of the forces on the bone wrench.

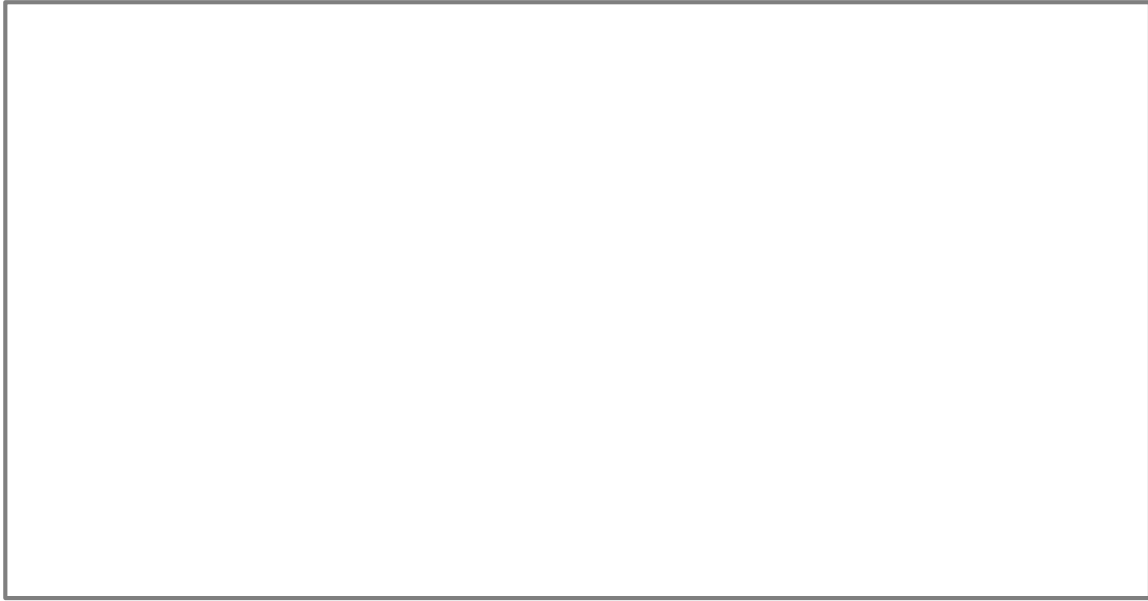

Using the files in "BoneWrench.SLDPRT" set up a linear static analysis using the loads from the Free-body diagram. Use simple boundary conditions to represent the system.

Complete a "Simulation Check" and "Simulation Record" for the analysis.

Class Exercise W03 Ex2 – Corkscrew

Analysis Brief

The force required to pull the cork out of the top of a wine bottle is in the range of 200 to 400 N. You are required to perform a design check on the handle of a new corkscrew.

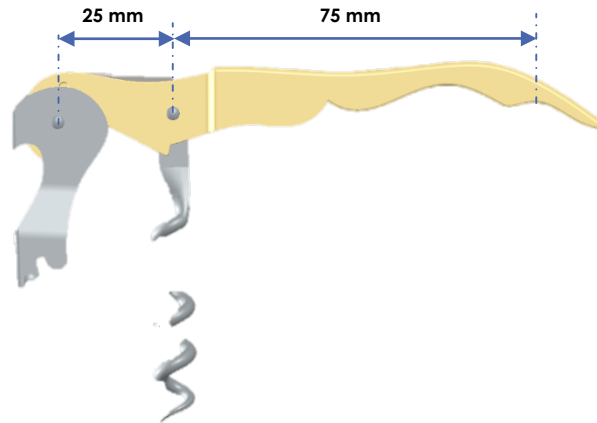

What assumptions are used about the loading? _____

Draw a Free-body diagram for the body of the corkscrew to balance the forces.



Using the files in “2 Step Corkscrew.zip” set up a linear static analysis using the loads from the Free-body diagram. Use simple boundary conditions to represent the system.

The planned material for the part is a 6061 Aluminum Alloy; $E = 69 \text{ GPa}$, Poisson's Ratio = 0.33, will this be sufficient for the part? Yes/No

What is your reason for this decision? _____

If not can you suggest an alternative material? _____

Design Analysis – Sample Questions



Exam Process (2 hours)

A zip file is provided containing all files required to complete the exam. Extract the folder to the desktop and ensure that all your work is saved in this folder regularly to avoid lost data.

For each question; open the part eg. “*Q01.SLDPRT*” and rename it to include you student number, i.e.

- *Q01_c00711111.SLDPRT*

Use Tabs for multiple simulations in a single file, include a tab name that describes the simulation, eg. “*Q1a Static*”.

Use **MMGS** settings in Solidworks and **MPa** for stress in all answers **including plot legends**.

Include units in all answers i.e. mm, Mpa

Design Analysis – Sample Questions

Open the part “Sample Q01.SLDPRT”.

The Plate shown (Alloy Steel SS) has a single bolt holding it to a wall with a 20 mm washer in contact with the front face.

A **vertical** mass of 50 Kg is applied through a second bolt hole with a 20 mm washer.

Restrain the part to represent the bolt, washer and contact with the wall.

- a) Using the default mesh size calculate the maximum stress and maximum displacement.

Default Mesh Size (mm) _____

Max Stress _____

Max Displacement: _____

- b) Create additional studies **in new tabs** to manually refine the mesh using the Solidworks mesh tools to find a suitable mesh for a 10% convergence criteria.

Converged Mesh Size (mm) _____

Max Stress _____

Max Displacement: _____

- c) Is the part suitable for use? _____

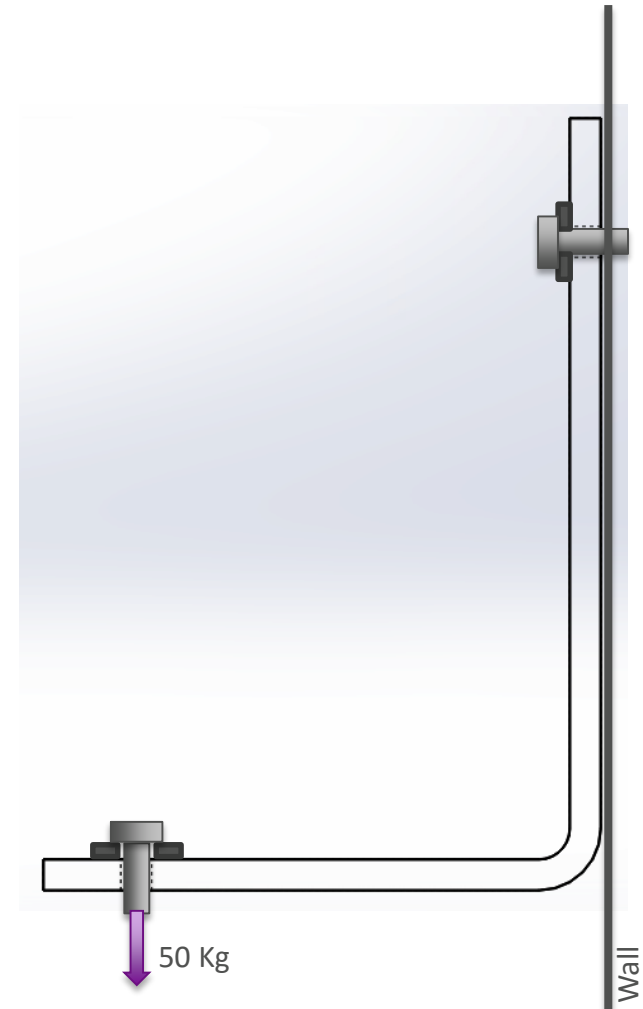

Design Analysis – Sample Questions



Open the part “Sample Q02.SLDPRT”.

The plate shown is made from Alloy Steel.
One end is **fully restrained**, the other has a 100,000 N horizontal force putting the plate in **tension**.

Restrain the part to represent these conditions and apply the Alloy steel model material.

- a) Using a 4.5 mm curvature based mesh find the maximum von Mises stress and maximum displacement in both the x and y directions.
Max Stress. _____
Max Displacement (x axis) _____
Max Displacement (y axis) _____
- b) What is the minimum factor of safety (FoS) in the plate based on the von Mises yield stress of the material?

Create a plot showing the areas where the FoS is below 2.

What does this mean if the design FoS is 2?

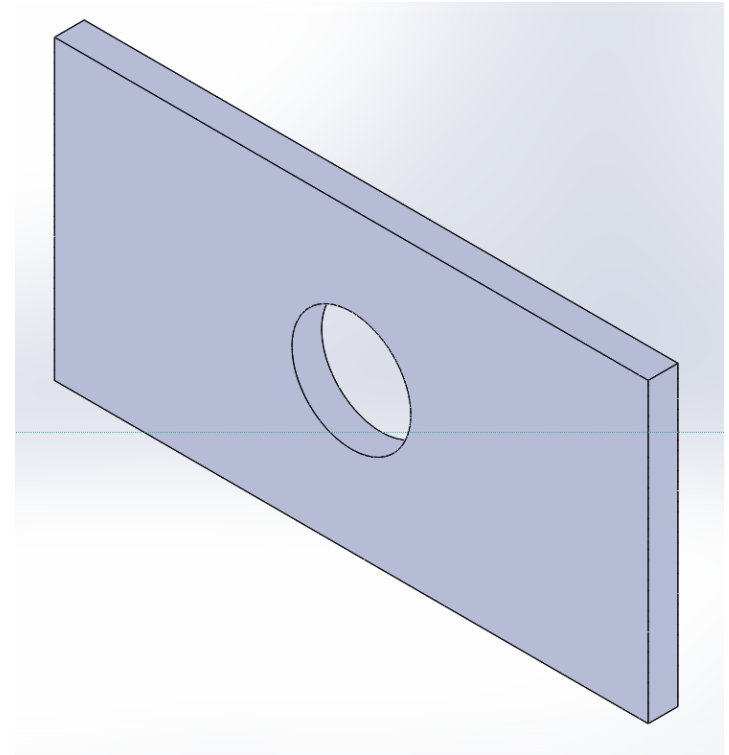

Design Analysis – Sample Questions

Open the part “Sample Q03.SLDPRT”.

The plate shown is made from Alloy Steel.
 One end is **fully restrained**, the other has a 100,000 N horizontal force putting the plate in **tension**.

Create an analysis to represent these conditions with an Alloy steel model material.

- a) Edit the part to apply suitable symmetry boundary conditions.

Which axes can symmetry be applied? _____

Why can these be applied? _____

Calculate the following in relation to the **mid point of the edge shown (1)**:

Max Stress. _____

Max Displacement (x axis) _____

Max Displacement (y axis) _____

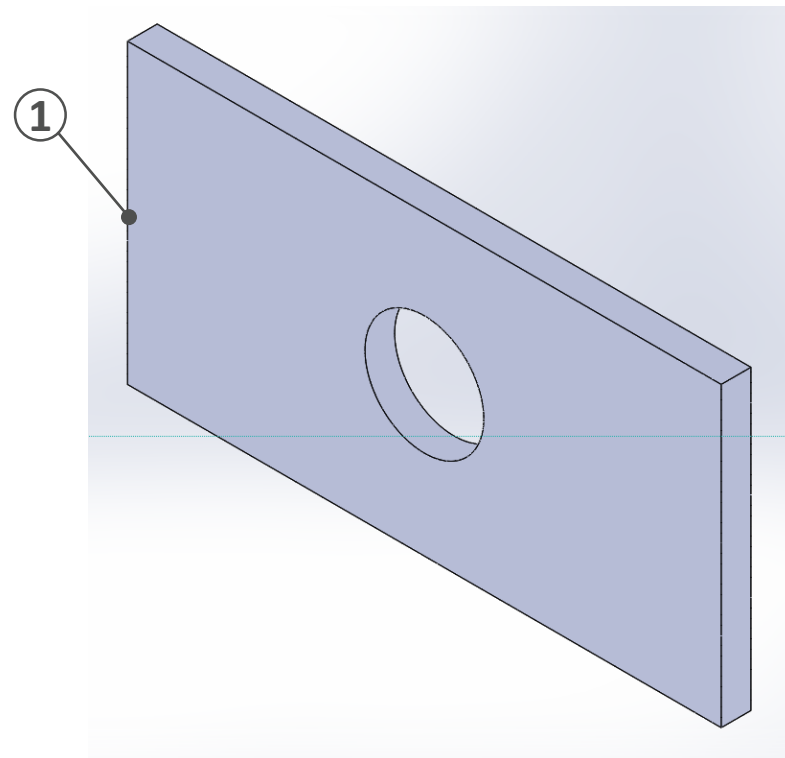

Design Analysis – Sample Questions

Open the part “Sample Q04.SLDPRT”.

The 10 mm plate shown is made from Alloy Steel.
One end is **fully restrained**, the other has a 100,000 N horizontal force putting the plate in **tension**.

Simplify the analysis using **2D simplification tools**.

Restrain the part to represent these conditions and apply the Alloy steel model material.

- a) Using a suitable 4 mm mesh calculate the maximum stress and maximum displacement in x y.

Max Stress. _____

Max Displacement (Resultant) _____

Max Displacement (x axis) _____

Max Displacement (y axis) _____

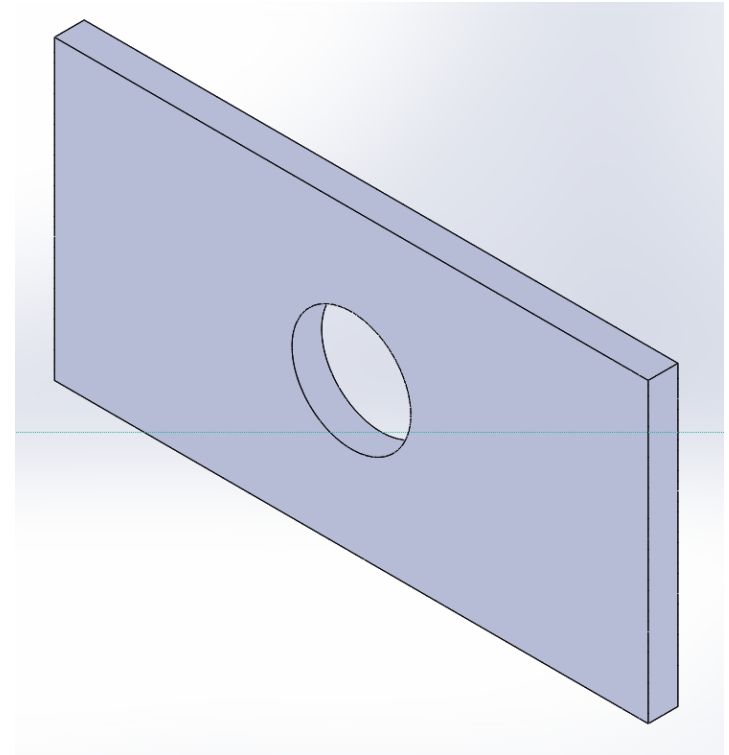

Design Analysis – Sample Questions

Open the part “Sample Q05.SLDPRT”.

The wrench shown is used to tighten a bolt. The bolt makes contact with the faces in red (1), and is tightened to **3 N.m** around Axis 1. The force required to generate this torque is applied **normal** to the face in green (2).

Build an analysis to represent this action, use a **suitable meshing process** to capture the part detail but reduce the number of elements.

a) What is the force required? _____

Which Material is suitable for this part:
6061 Alloy Aluminium / Alloy Steel

b) Max Stress. _____

Max Displacement (Resultant) _____

Minimum (von Mises) factor of safety (FoS)

If the FoS for the design of the part is 8, is the part suitable for use? _____

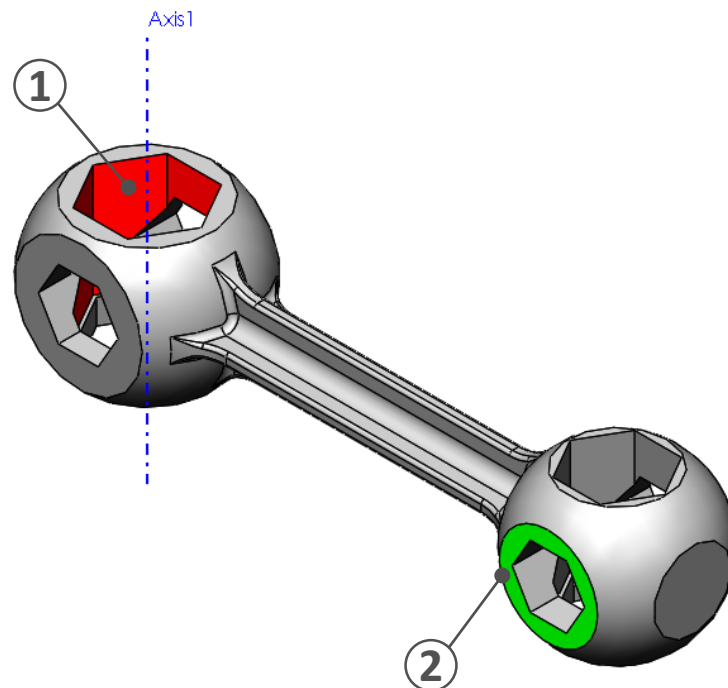

Design Analysis – Sample Questions

Open the part “Sample Q06.SLDPRT”.

The plate shown (Alloy Steel) is restrained at the two bolt holes (1) and undergoes a **vertical displacement** of 0.1 mm at the third hole (2). Build an analysis to represent this action

Manually control the mesh in the highlighted area to create **5 elements** along the arc of the fillet. **Use the default mesh settings** for the remainder of the part.

a) Refined mesh size _____
 Max Stress. _____

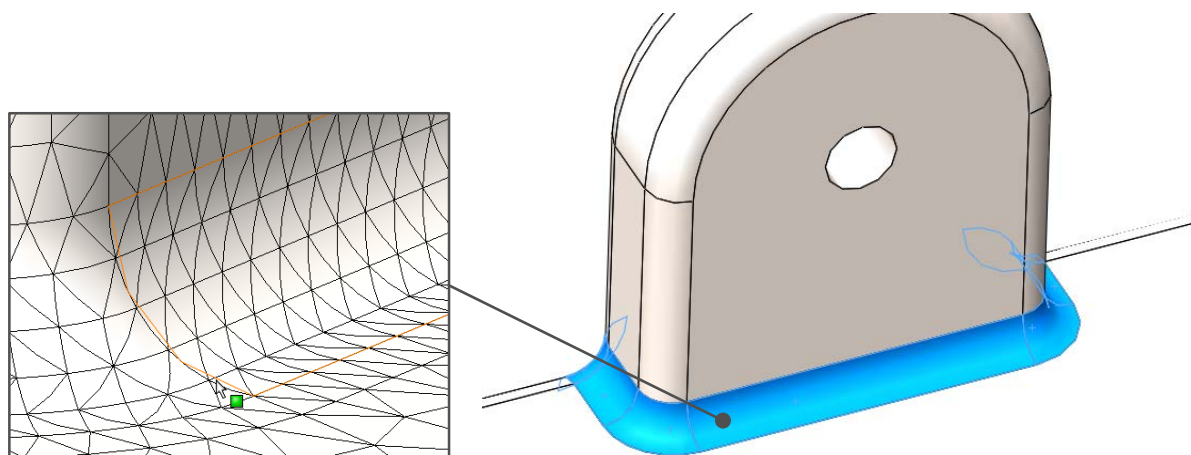
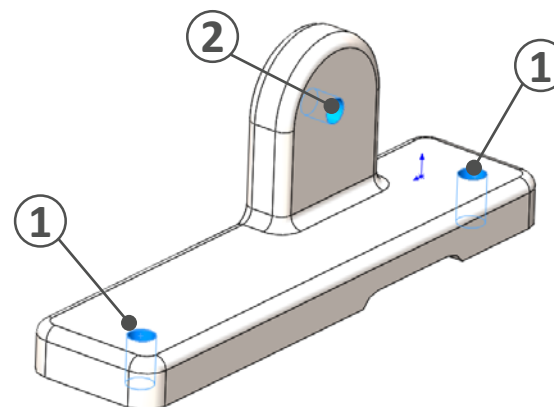

Design Analysis – Sample Questions

Open the part “Sample Q07.SLDPRT”.

The part shown (Plain Carbon Steel) is restrained at the centre (1) and has a **pressure of 5 N/mm²** applied around its edge (2).

Build an analysis to represent this action using **cyclic symmetry** to reduce the element count.

- a) Max Stress. _____
Max Displacement (Resultant) _____

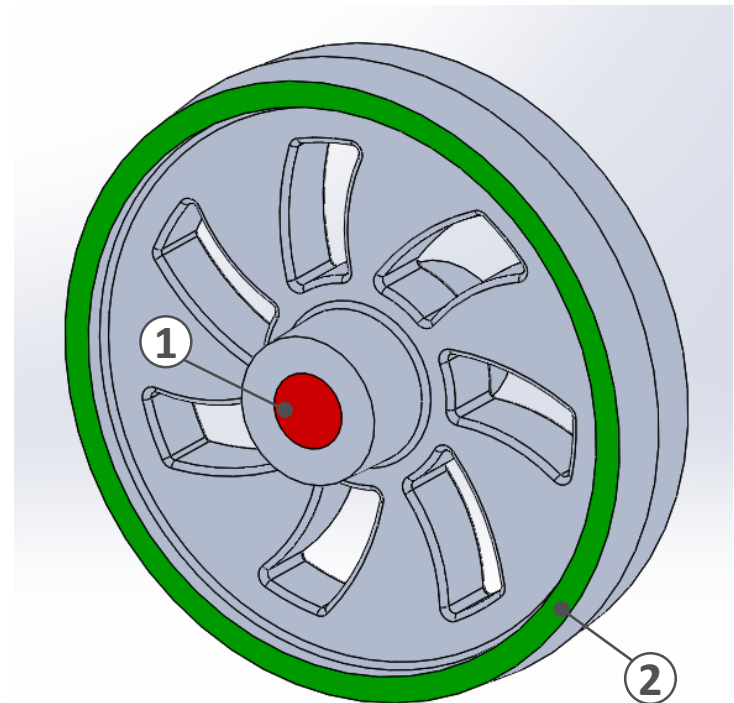

Design Analysis – Sample Questions

Open the part “Sample Q08.SLDPRT”.

The part shown (Chrome Stainless Steel) is restrained at the ends (1) with **pin joints** and has a **total vertical force** of 30000 N on the bearing surface (2).

Build an analysis using **8 mm curvature based mesh** to represent this action using **symmetry** to reduce the element count.

- a) Max Stress (von Mises) _____
 Max Displacement (Resultant) _____

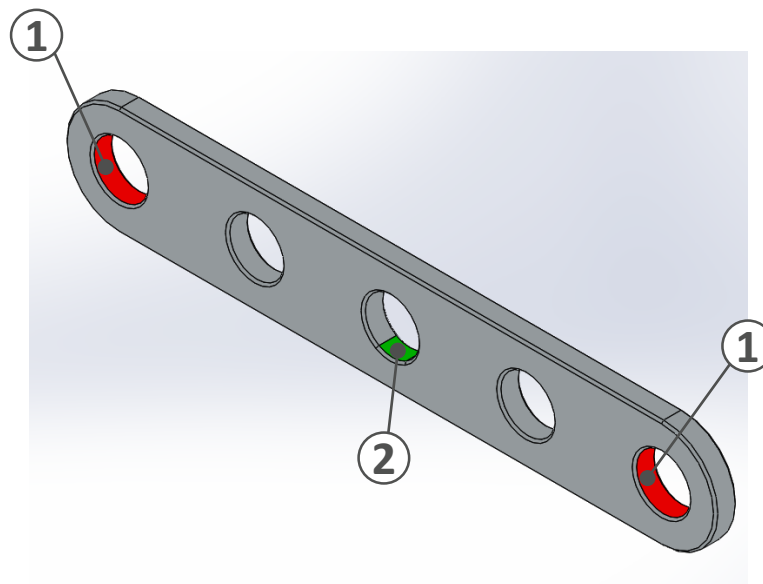

Design Analysis – Sample Questions

Open the part “Sample Q09.SLDPRT”.

The pressure vessel shown (Alloy Steel SS) is to be tested to an internal pressure of 1.4 N/mm^2 .

Simplify the analysis using **2D simplification tools** and build an analysis to represent this test using a **4 mm mesh**.

a) Max Stress (von Mises) _____

How much does the tank expand in the radial direction? _____

How much does the tank lengthen in the axial direction? _____

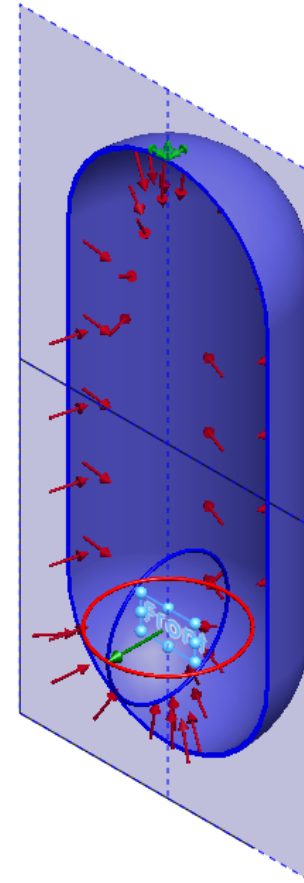

Design Analysis – Sample Questions

Open the part “Sample Q10.SLDPRT”.

The cantilever beam shown (Alloy Steel) is fully constrained at one end and subject to a vertical force of 2000 N at the other.

Simplify the analysis to a **1D Beam** with **10 elements** along its length.

- a) Max Stress (Upper Bound & Bending) _____
Beam Tip Displacement (mm) _____
Max Moment (N.m) _____

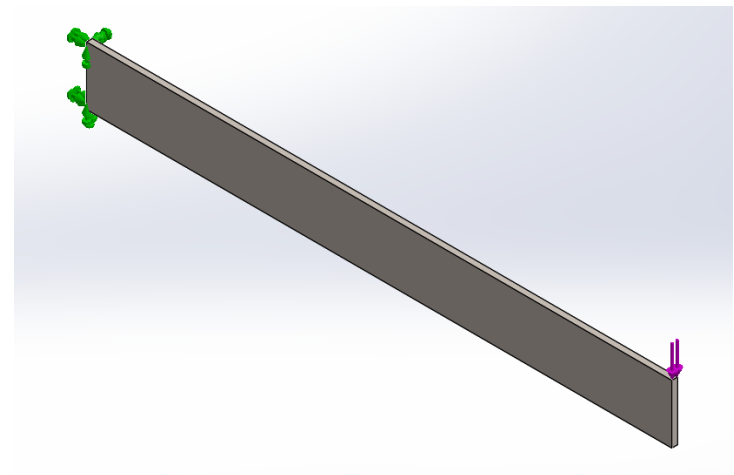

Design Analysis – Sample Questions

Open the part “Sample Q11.SLDASM”.

A heatsink (1060 Alloy) (1) removes heat from a Ceramic microchip (2) generating a total of **25 W of heat power**.

If the interface has a **Thermal Resistance of 0.0001 K.m²/W** and the heatsink transfers **25 W/(m²K)** to the air through convection in an ambient temperature of **300 Kelvin**.

Mesh the parts using a **4 mm curvature based mesh** and find:

a) Max System Temp (Celsius) _____

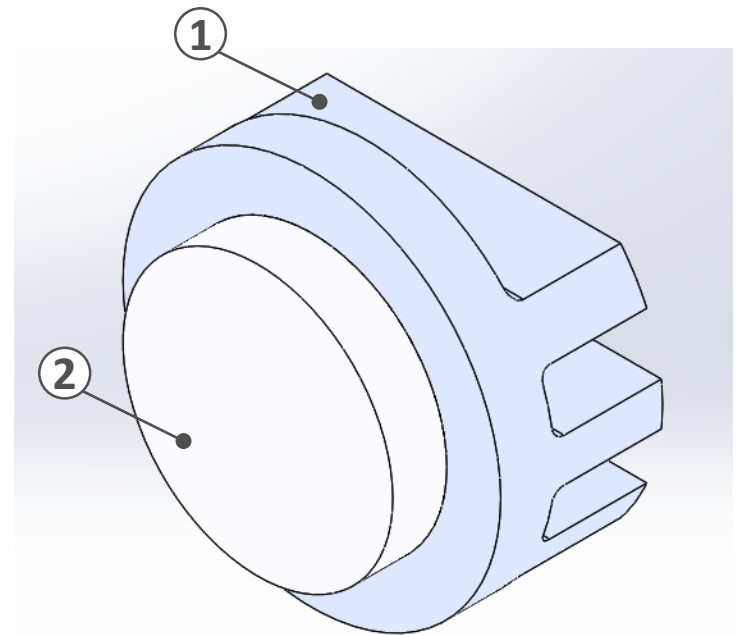

Design Analysis – Sample Questions

Open the part “Sample Q12.SLDASM”.

The temperature of the bi-metallic strip (Plain Carbon Steel & Aluminium 1060) shown **increases from an initial 25 °C to 125 °C**.

Create a fixture at the base of the strip (1) which **allows expansion** in the plane but avoids rigid body motion.

Find:

- a) Max Stress (von Mises) _____
 Beam Tip Displacement (mm) _____

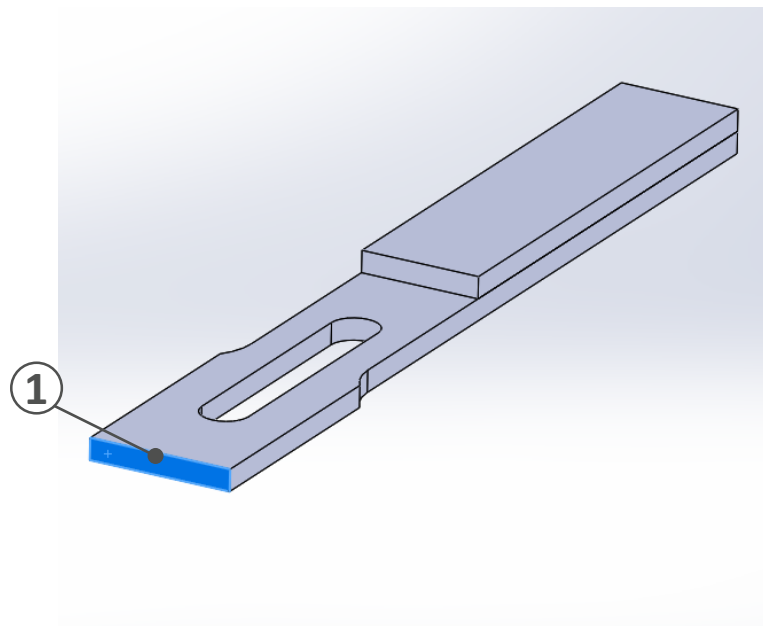

Design Analysis – Sample Questions

Open the part “Sample Q13.SLDASM”.

The welded bracket shown (AISI 304) has a **fixed restraint** along its back face (1) and a **1000 N load pushing down** normal to the washer area at a bolt hole (2).

The area where the vertical back plate meets the angled beam (3) is broken and has is **free to slide** up and down the back plate with a friction **coefficient of 0.05**.

All other joints are bonded under global contact rules.

Mesh the parts with the default mesh settings and find:

- a) Max Stress (von Mises) _____
- Max Tip Displacement (mm) _____
- Displacement at sliding face (3) _____
- Hint: Use Probe Tool

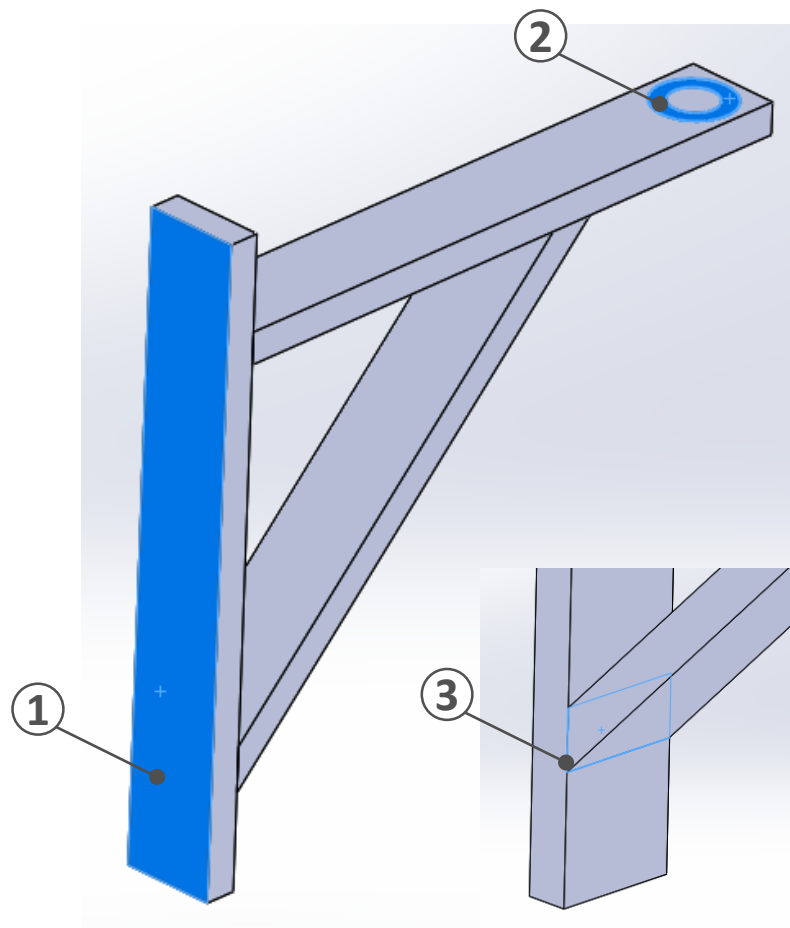

4.b PROYECTO



Simulation Record Combination wrench

for

Design analysis. Assignment 01

Jaume Luna Alapont

D15126904

05/04/2016

Simulation Record	
Course:	Design Analysis
Simulation/Project Name:	Assignment 01 – Combination Wrench (9mm)
Student Name:	Jaume Luna Alapont
Student #:	D15129604

1. Simulation Description:

Goals for this simulation are verifying that the 9 mm wrench will support the stress in which the spanner will be put to, in regular use situations. The torque necessary to open/close a nut is given so a force calculated depending on the dimensions of the spanner will be applied to the upper opposite part of it simulating the hand effort.

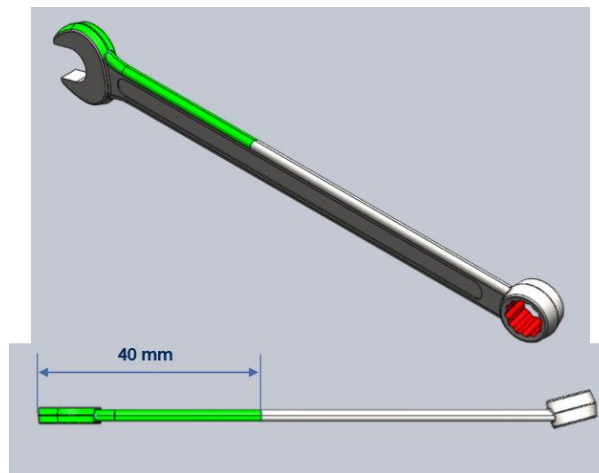

With these simulation its pretended to find if the spanner will exceed the plastic deformation and if that's the case give a solution.

Category of importance	DE. - Design Exploration
Analysis type	Plastic deformation, break estimation, design verification and optimisation if necessary.
Product type	Mechanic tool, spanner.

2. Required Output

Stress that the handle suffers to be compared with the yield stress.

Displacement of the spanner.

Results details from the union between the handle and the bolt subsection cylinder.

Material comparison.

Results Format	Design check sheet, Detailed report, Optimised CAD file.
----------------	--

Simulation Record	
Course:	Design Analysis
Simulation/Project Name:	Assignment 01 – Combination Wrench (9mm)
Student Name:	Jaume Luna Alapont
Student #:	D15129604

3. Simulation Details

Modelling Assumptions & Idealisation

A force is applied to the first 40 mm of the upper spanner part.

The area in contact with the nut is completely fixed.

The material used is linear, Alloy steel (0X2CrNiMoN22-5-3).

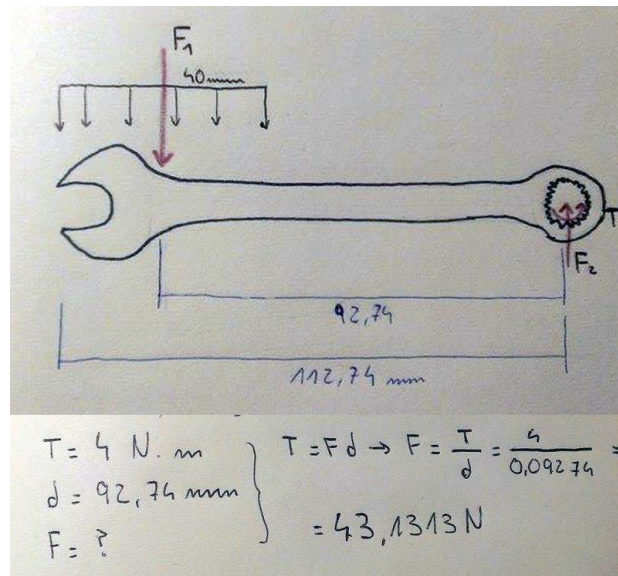

Geometry Analysed (Region of Interest):

The main interest area is the handle spanner, perceived as the middle part, and the most sensible part of stress will be the end of the handle in contact with the bolt subsection.

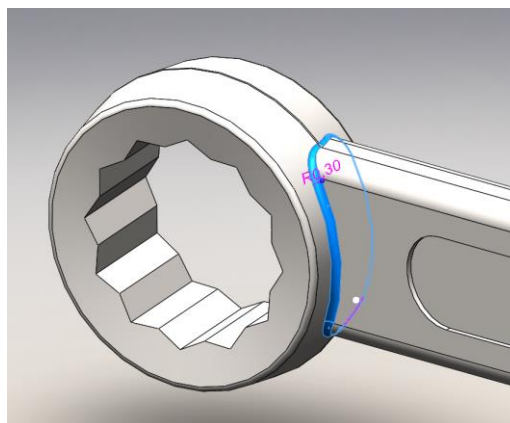

Simulation Record	
Course:	Design Analysis
Simulation/Project Name:	Assignment 01 – Combination Wrench (9mm)
Student Name:	Jaume Luna Alapont
Student #:	D15129604

Three surfaces from the handle have been split to a more accurate application of the forces by the creation of a new plane geometry and a line in it.

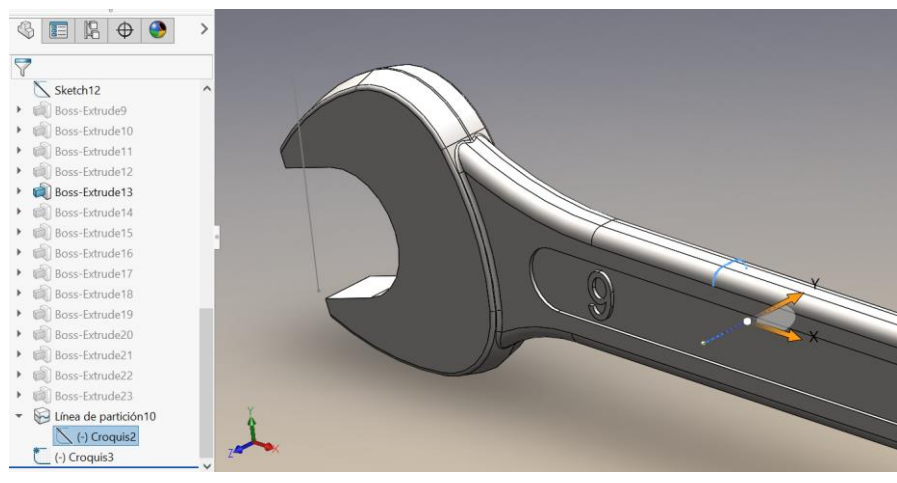

Geometry file(s)	Combination Wrench - Table Driven9mm
------------------	--------------------------------------

Material Model(s)

The planned material for the part is a Stainless Steel: E= 200 GPa, Poisson's Ratio = 0.28, with a Yield Stress of 650 MPa.

Material Details	
Study name	Análisis estático 1 (-9-)
Material name	1.4462 (X2CrNiMoN22-5-3)
Material source	Simulation library
Model type	Linear Elastic Isotropic
EX	2E+011 N/m ²
NUXY	0.28
GXY	7.9E+010 N/m ²
DENS	7800 kg/m ³
SIGXT	8.5E+008 N/m ²
SIGYLD	6.5E+008 N/m ²
ALPX	1.1E-005 /Kelvin
KX	14 W/(m.K)
C	440 J/(kg.K)

Material references	0X2CrNiMoN22-5-3
---------------------	------------------

Simulation Record	
Course:	Design Analysis
Simulation/Project Name:	Assignment 01 – Combination Wrench (9mm)
Student Name:	Jaume Luna Alapont
Student #:	D15129604

Load Details

A force is applied to the first 40 mm of the upper spanner part, so simulates the area in contact that the hand would be in. The load is 43,1313 N and is directed into the down part.

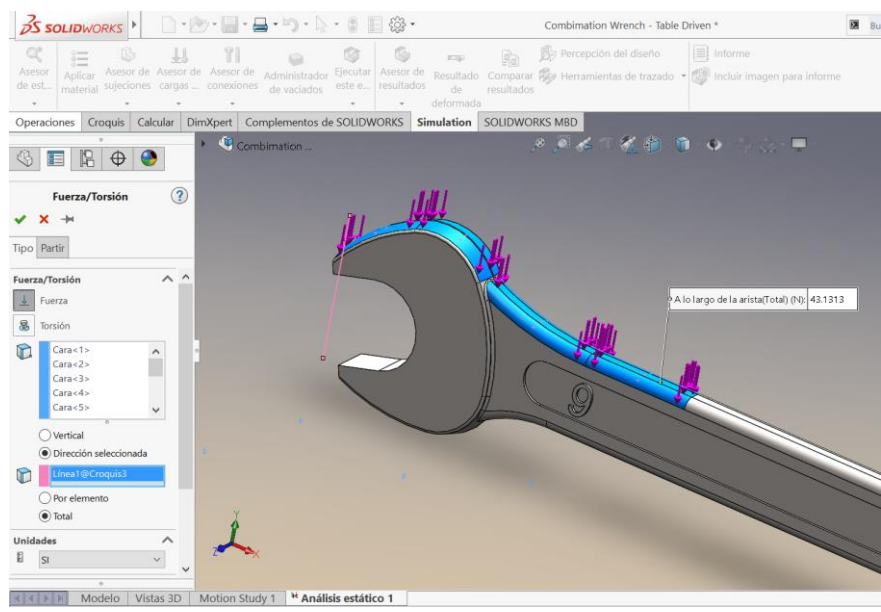

Boundary Constraint Details

The area in contact with the nut is completely fixed so the simulation will show the moment of higher stress in the handle of the spanner.

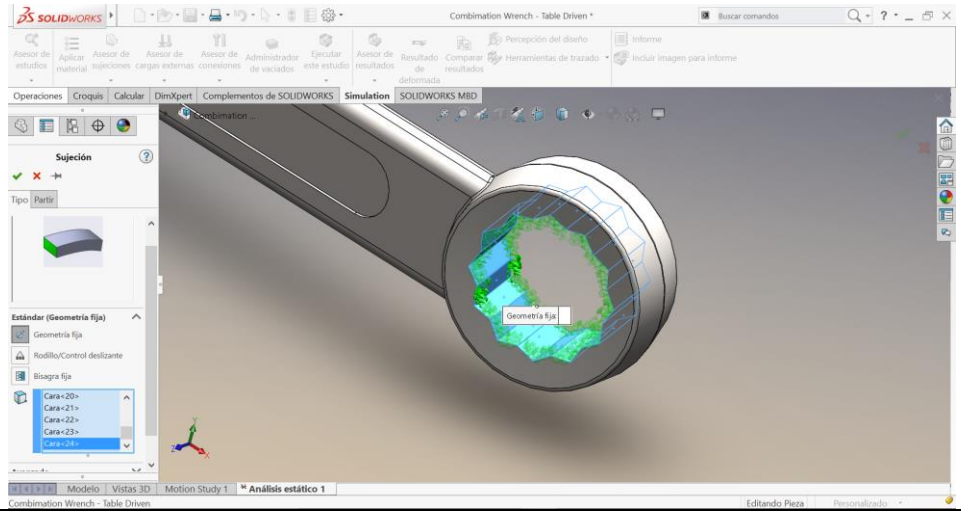

Simulation Record	
Course:	Design Analysis
Simulation/Project Name:	Assignment 01 – Combination Wrench (9mm)
Student Name:	Jaume Luna Alapont
Student #:	D15129604

Mesh Details

First a standard mesh command is used where all elements have the same size. The maximum stress here is 160 MPa.

Mesh Details	
Study name	Análisis estático 1 (-9-)
Mesh type	Solid Mesh
Mesher Used	Standard mesh
Automatic Transition	Off
Include Mesh Auto Loops	Off
Jacobian points	4 points
Element size	1.53034 mm
Tolerance	0.0765172 mm
Mesh quality	High
Total nodes	20053
Total elements	11776
Maximum Aspect Ratio	106.91
Percentage of elements with Aspect Ratio < 3	85
Percentage of elements with Aspect Ratio > 10	0.756
% of distorted elements (Jacobian)	0
Time to complete mesh(hh:mm:ss)	00:00:05
Computer name	

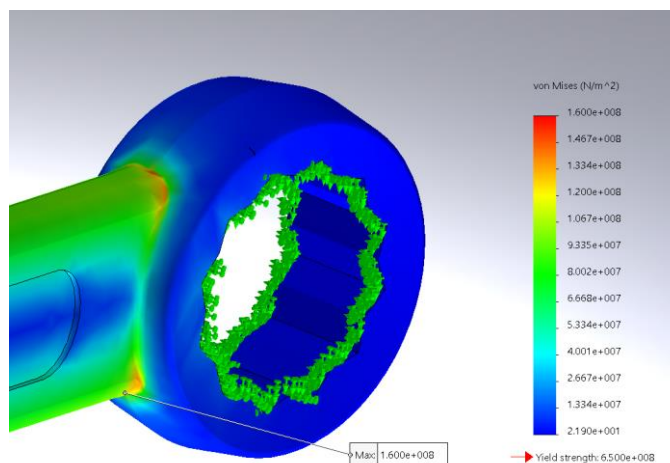
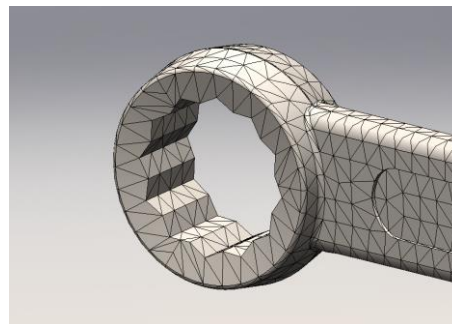

Simulation Record	
Course:	Design Analysis
Simulation/Project Name:	Assignment 01 – Combination Wrench (9mm)
Student Name:	Jaume Luna Alapont
Student #:	D15129604

And after, for more precise results a curvature-based command is used where the curve of interest gets more element so the results in these area will be better. And the maximum stress would be 173 MPa.

Mesh Details

Study name	Análisis estático 1 (-9-)
Mesh type	Solid Mesh
Mesher Used	Curvature-based mesh
Jacobian points	4 points
Max Element Size	3.06069 mm
Min Element Size	0.612137 mm
Mesh quality	High
Total nodes	38511
Total elements	23225
Maximum Aspect Ratio	29.319
Percentage of elements with Aspect Ratio < 3	87.5
Percentage of elements with Aspect Ratio > 10	0.435
% of distorted elements (Jacobian)	0
Time to complete mesh(hh:mm:ss)	00:00:03
Computer name	

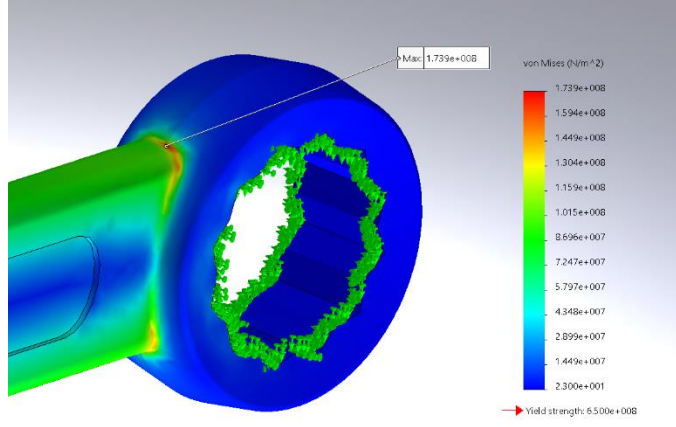
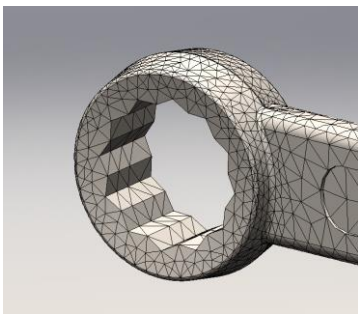

Element types	3D Tetra elements
Meshing controls	Curvature-based mesh to get more accurate results in the weak areas of study.
Mesh checks & results	In order to find the Convergence values where the simulation is more accurate and real, manual graphs have been created. With the standard parameters.

Simulation Record	
Course:	Design Analysis
Simulation/Project Name:	Assignment 01 – Combination Wrench (9mm)
Student Name:	Jaume Luna Alapont
Student #:	D15129604

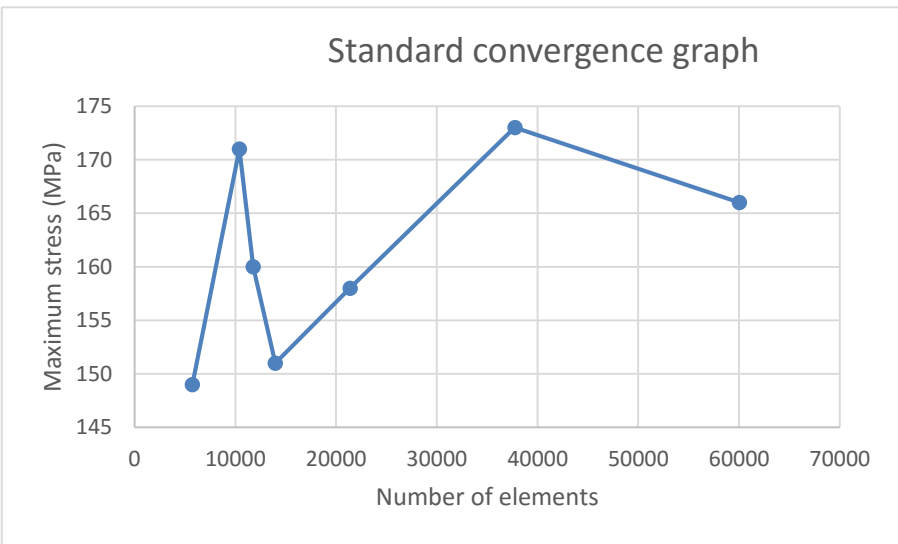

With curvature-based parameters.

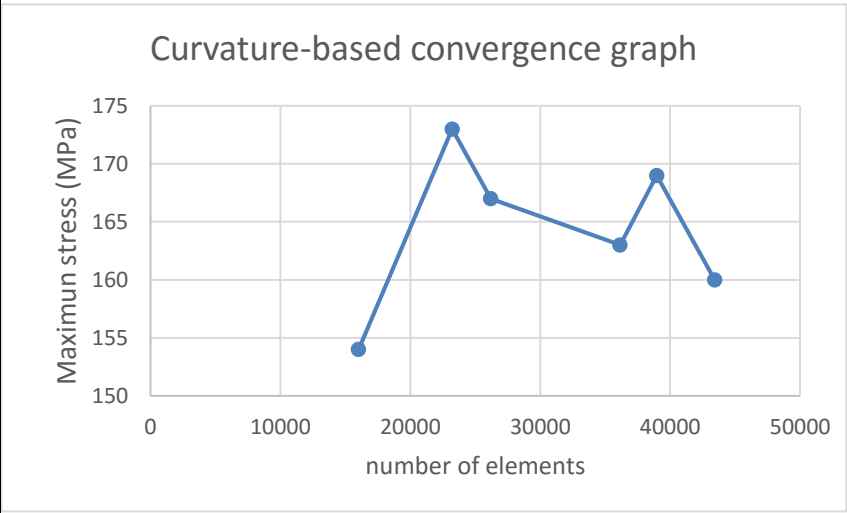

Simulation Record	
Course:	Design Analysis
Simulation/Project Name:	Assignment 01 – Combination Wrench (9mm)
Student Name:	Jaume Luna Alapont
Student #:	D15129604

A part from the manual values collection Solidworks can create the convergence graph by itself.

These is the convergence graph with the curvature-based parameters.

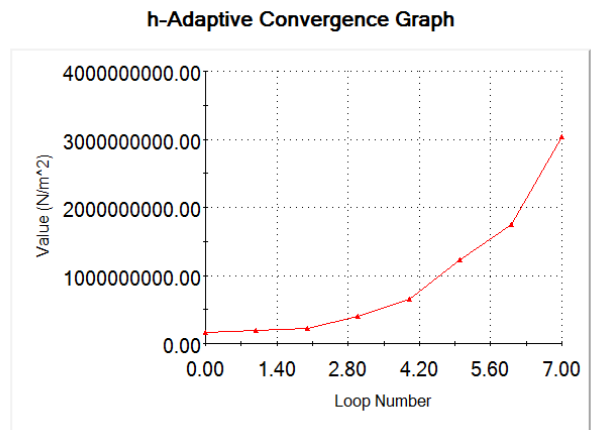

Global Criterion: Total relative Strain Energy Norm error < 1.22916%

—●— Maximum von Mises Stress

2.45892, 4.2963e+009

Solver Set-up

Solidworks FFEPlus

Assessment & Validation

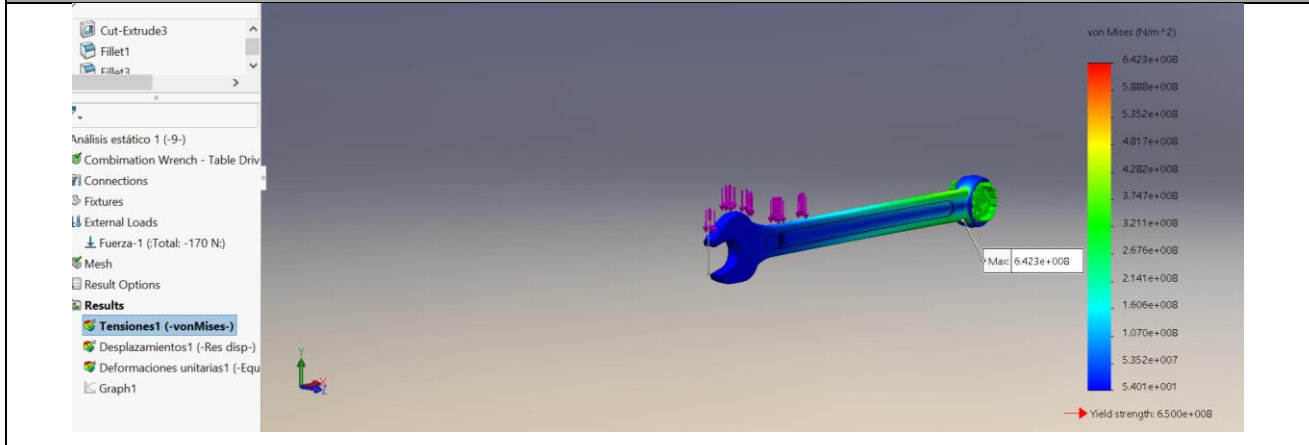

Simulation Record	
Course:	Design Analysis
Simulation/Project Name:	Assignment 01 – Combination Wrench (9mm)
Student Name:	Jaume Luna Alapont
Student #:	D15129604

<p>The approximate torque that the spanner resists is 15.76 N.m, in which the strength applied would be 170 N. So in these case the maximum stress doesn't goes over the yield stress of the material in any part of the spanner.</p>	
Validation references	-

4. Summary of Principle Results

Maximum stress is 162 MPa, while the stress yield is 650 MPa.
 Maximum displacement is 0.411 mm, while just the displacement over 3 mm is considered wrong. //
 These results have been obtained with a curvature based mesh optio with a total amount of 31068 elements.

5. Discussion of Results

The force applied in these regular usage conditions doesn't change the product properties because the results are inside the elastic deformation of the material, also there's one part of the handle that suffers more stress than the other because of the oblique direction of the handle respect to the bolt.

6. Conclusions & Recommendations

The results confirm that the product works in regular conditions.

7. Analysis File Details

Solidworks file name: "Combination wrench – TableDriven9mm"

Simulation Record	
Course:	Design Analysis
Simulation/Project Name:	Assignment 01 – Combination Wrench (9mm)
Student Name:	Jaume Luna Alapont
Student #:	D15129604

8. Appendices A – Simulation Check

Simulation check9mm (pdf attached)

9. Appendices B – Free-Body diagram and design questions

Free-Body diagram and design questions (pdf attached)

