

FINAL DEGREE PROJECT

RESEARCH ABOUT
ASSEMBLY DESIGNS



POLITECNICO
MILANO 1863

2017

Adrián Martínez Conejero – Mechanical Engineering

INDEX:

Introduction-----	3
Gearboxes-----	4
Audi Q7-----	4
Volkswagen Touareg-----	15
Definition of parts-----	26
Comparison between the two gearboxes-----	59

INTRODUCTION:

The gearbox is one of the basic elements of the drivetrain of a car, this old element has been developed since the last century with the first vehicles. In this project I'm going to study the design and the development of some gearboxes of two cars of the VW group. This cars are the big SUV's that are trendy nowadays, the Audi Q7 and the Volkswagen Touareg. They use automatic transmissions, one of them with an 8 speed gearbox and the other one with an 8 speed gearbox, this last one is a newer model of the 6 speed gearbox and I will describe what improvements have the newer gearbox in comparison with the old one. The most important factors are the disposition of the gearbox, their size, shape and the inner design, in the next part we will see the different parts of the gearboxes and how they are mounted, seeing too the differences between a mechanical differential and the electrical differential.



Volkswagen Touareg (2015)



Audi Q7 (2015)

GEARBOXES:

I have decided to compare 2 gearboxes of two actual cars of the Volkswagen group. These cars are a Audi Q7 (2015) V6 Diesel 3.0 TDI and an automatic transmission with 6 gears and a Volkswagen Touareg (2015) V6 Diesel 3.0 TDI and an automatic transmission with 8 gears.

This cars are of the same group but their transmissions have different solutions and elements, like the number of gears or the different types of differentials for the 4x4 traction.

This are the drawings of the transmissions of each car, with each part named and enumerated.

AUDI Q7(09D):

- Gearbox, complete, 6-speed automatic gearbox, for four-wheel drive

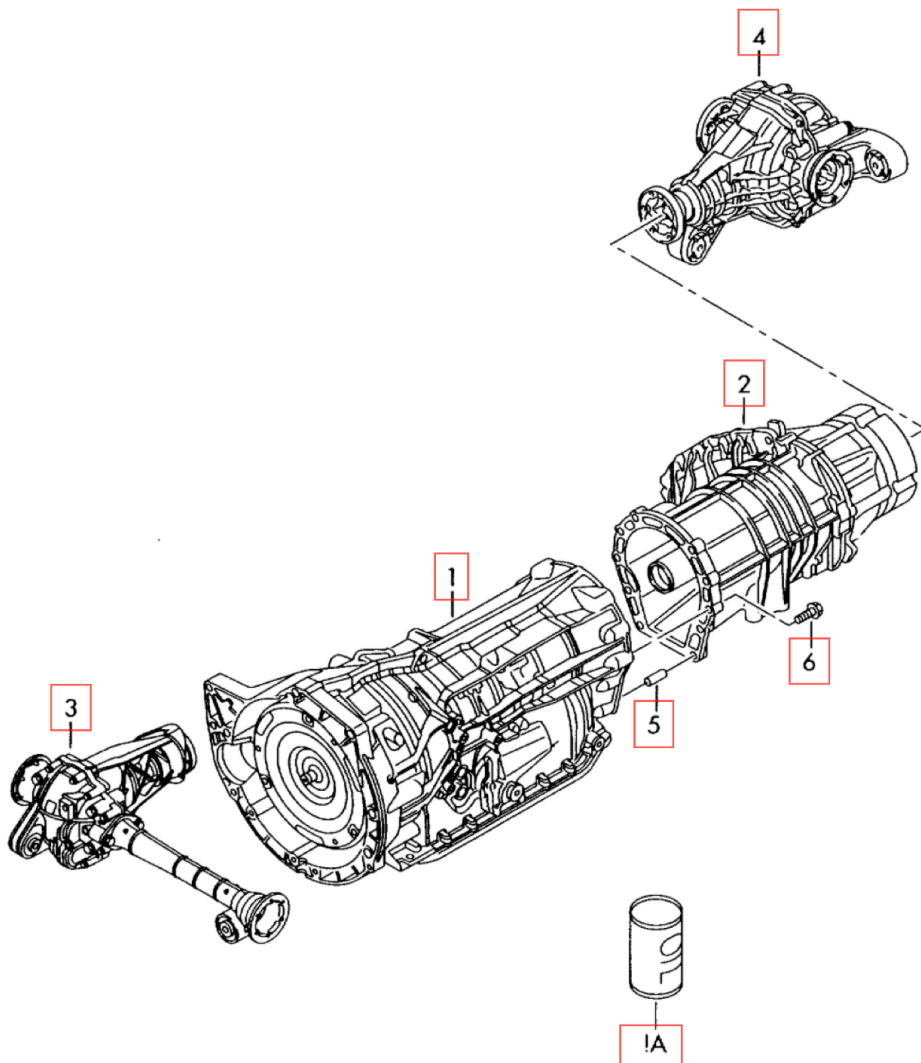

Parts:

N°	Title
1	6-speed automatic gearbox
1A	Automatic Transmission Fluid
2	Transfer box
3	Front axle differential
4	Rear axle differential
5	Sleeves
6	Sealing plug

- Transmission securing parts, 6-speed automatic gearbox, for four-wheel drive:

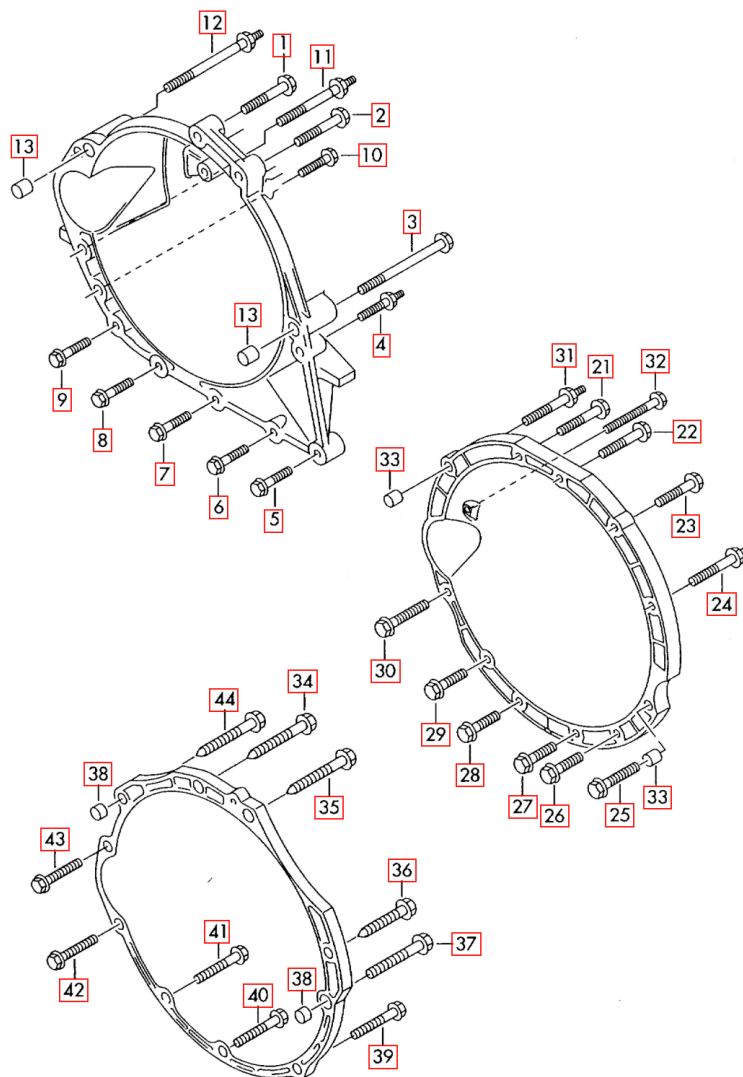

***Note:** The three parts are similar, so only one is explained piece by piece.

Parts:

N°	Title
34	Hexagon collared bolt with hexagon socket head (duo)
35	Hexagon collared bolt with hexagon socket head (duo)
36	Multi-point socket head bolt with collar
37	Hexagon collared bolt with hexagon socket head (duo)
38	Dowel sleeve
39	Hex collared bolt
40	Hex collared bolt
41	Hex collared bolt
42	Hex collared bolt
43	Hex collared bolt
44	Hexagon collared bolt with hexagon socket head (duo)

- Oil pressure line for gearbox oil cooling, for 6-speed automatic gearbox:

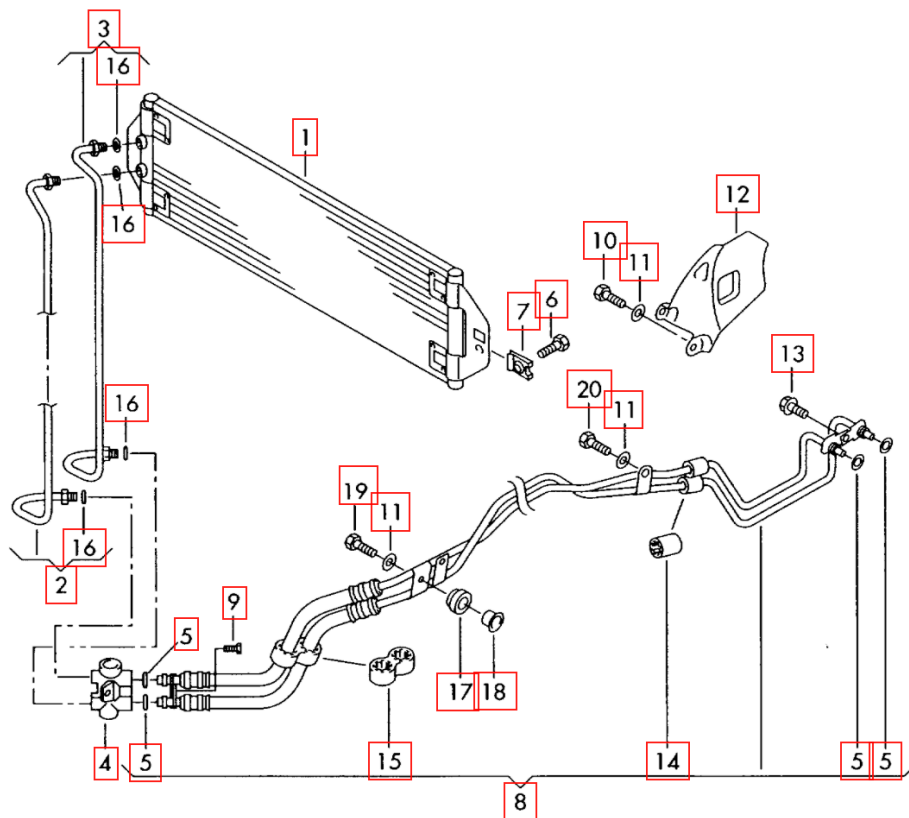

Parts:

N°	Title
1	Gear oil cooler
2	Oil pressure line
3	Oil pressure line
4	Oil temperature controller
5	O-ring
6	Oval hexagon socket head bolt
7	Retaining washer
8	Oil pressure line
9	Hexagon head bolt
10	Hexagon bolt
11	Washer
12	Guard plate
13	Hexagon head bolt
14	Protection
15	Protective hose
16	O-ring
17	Retaining washer
18	Sealing plug
19	Hexagon head bolt
20	Hexagon head bolt

- Converter, valve body, for 6-speed automatic gearbox, four-wheel drive:

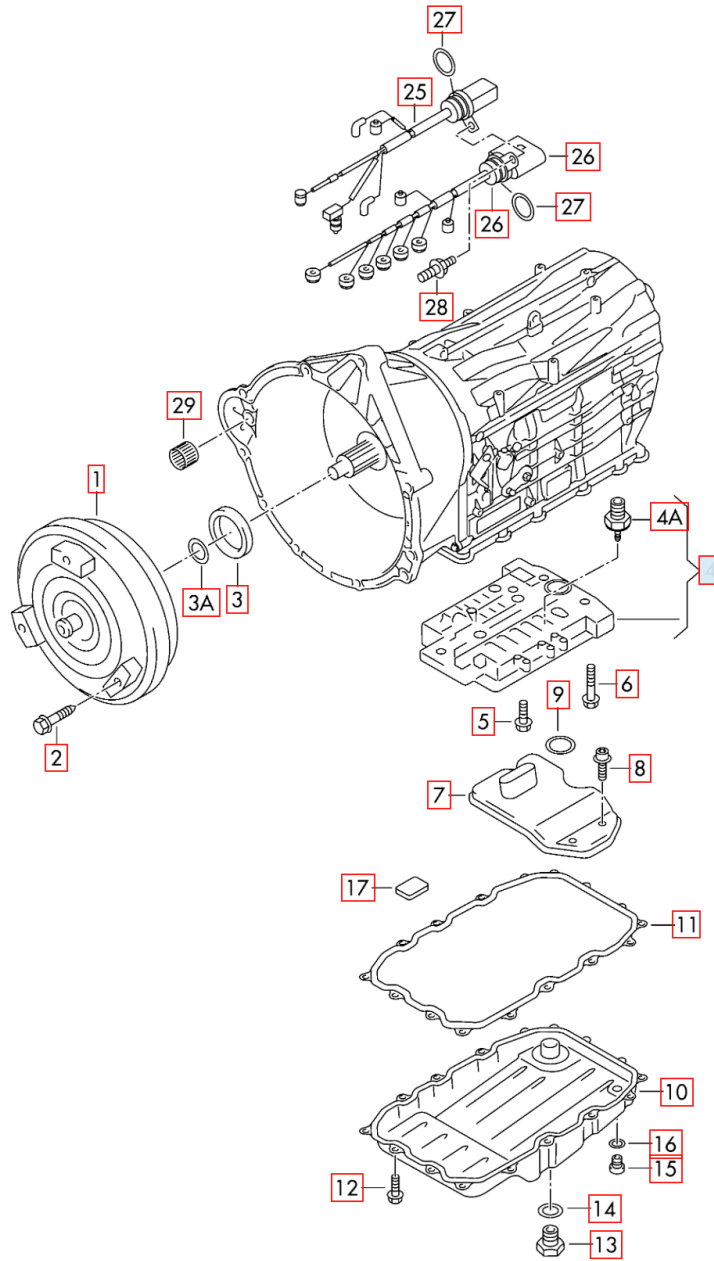

Parts:

N°	Title
1	Converter
2	Socket head bolt with hexagon
3	Radial shaft seal
3A	O-ring
4	Valve body
4A	Oil pressure switch
5	Hex collared bolt
6	Hexagon head bolt
7	Oil strainer
8	Hexagon head bolt
9	Seal
10	Transmission oil sump
11	Gasket for oil sump
12	Hexagon head bolt
13	Sealing plug
14	O-ring
15	Drain plug
16	O-ring
17	Magnet
27	O-ring
28	Double stud with hexagon drive

- Gear housing, guard plates, for 6-speed automatic gearbox, four-wheel drive:

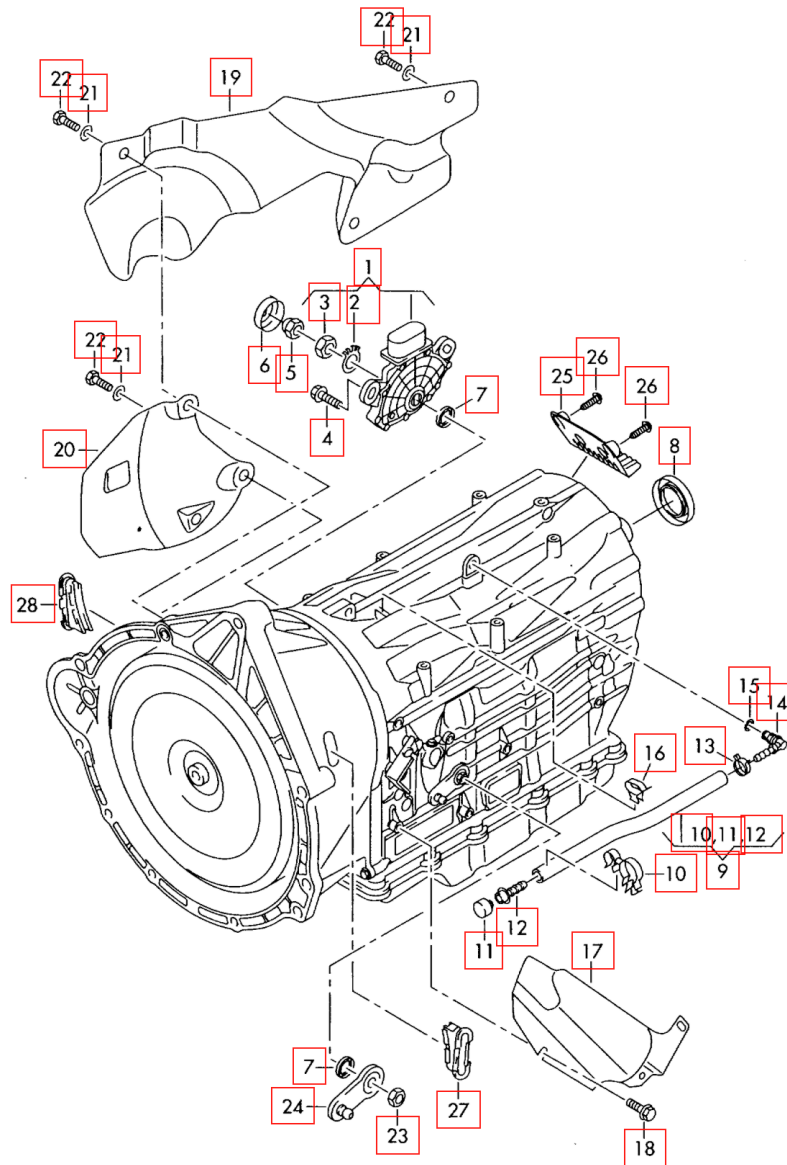

Parts:

N°	Title
1	Multi-function switch for automatic gearbox
2	Collar nut
3	Retaining washer
4	Hexagon bolt
5	Domed cap nut
6	Cover cap
7	Radial shaft seal
8	Radial shaft seal
9	Breather assy
10	Bracket

11	Cap for venting the gearbox
12	Ventilation union
13	Clip
14	Angled connector
15	O-ring
16	Clip
17	Guard plate
18	Hexagon head bolt
19	Guard plate
20	Guard plate
21	Washer
22	Hexagon bolt
23	Nut
24	Selector lever
25	Guard plate
26	Round hd. screw
27	Cover cap
28	Cover cap

- Transfer box, for 6-speed automatic gearbox:

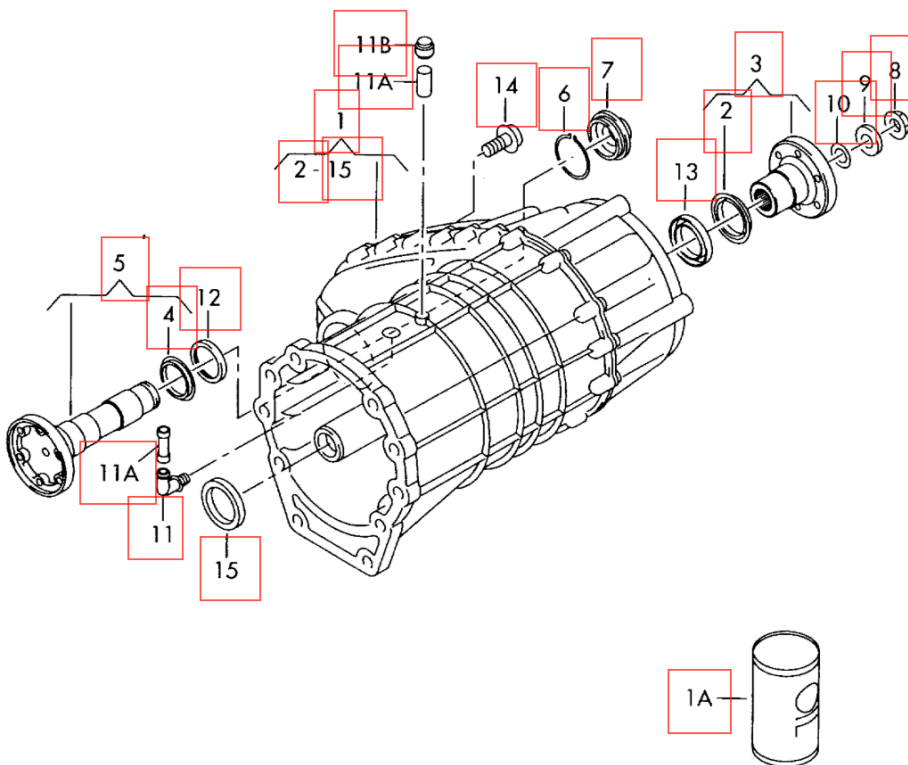

Parts:

N°	Title
1	Transfer box
1A	Automatic transm. fluid
2	Protective ring
3	Flange
4	Protective ring
5	Flange
6	Securing ring
7	Cover
8	Hexagon nut
9	Thrust washer
10	O-ring
11A	Sleeve
11B	Breather valve
12	Radial shaft seal
13	Radial shaft seal
14	Sealing plug
15	Radial shaft seal

- Drive chain, gears and shafts, for transfer box, for 6-speed automatic gearbox:

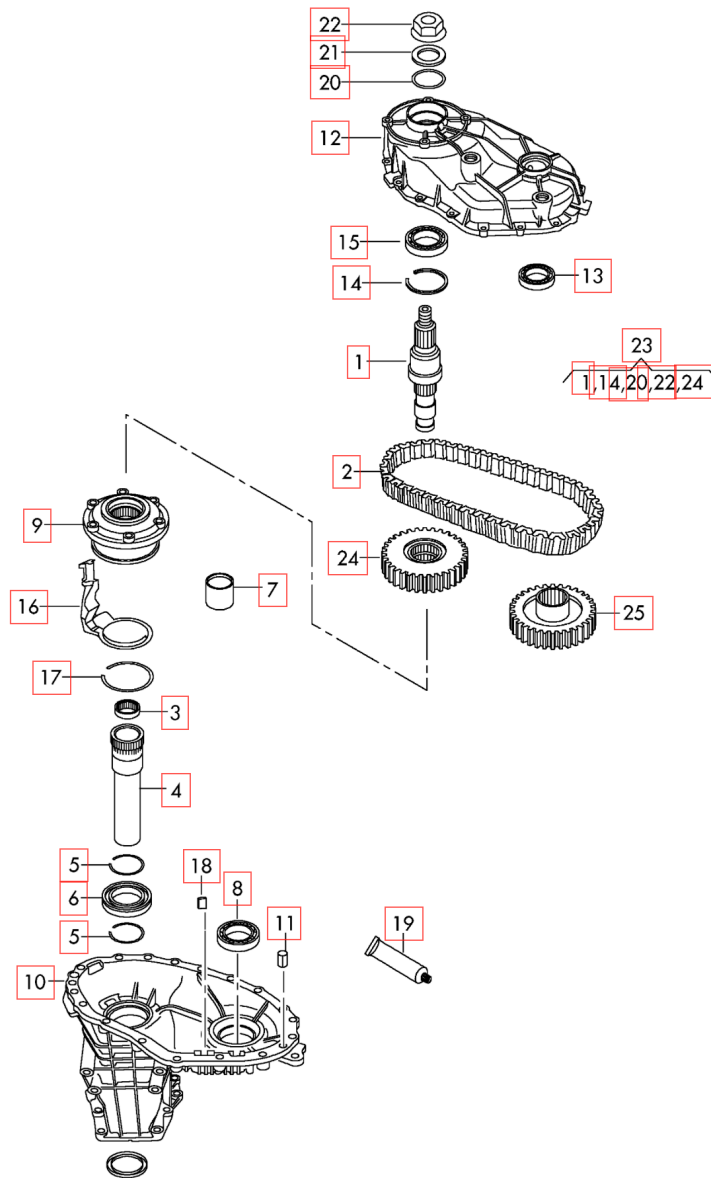

Parts:

N°	Title
1	Output shaft
2	Drive chain
3	Needle bearing
4	Input shaft
5	Securing ring
6	Grooved ball bearing
7	Sleeve
8	Grooved ball bearing
9	Centre differential
10	Case

11	Centre sleeve
12	Case
13	Grooved ball bearing
14	Securing ring
15	Grooved ball bearing
16	Oil drip tray
17	Securing ring
18	Magnet
19	Silicone sealant
20	O-ring
21	Thrust washer
22	Hexagon nut
24	Chain sprocket
25	Chain sprocket

- Securing parts for transfer box, for 6-speed automatic gearbox:

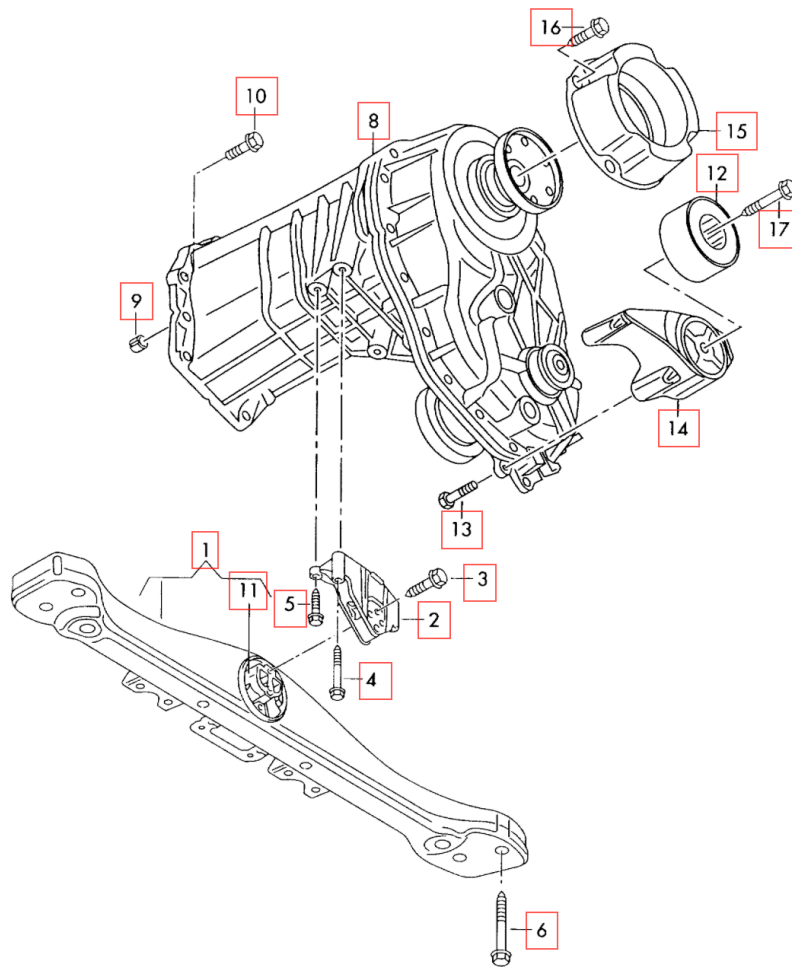

Parts:

N°	Title
1	Transmission carrier
2	Console
3	Bolt, hex. hd. with shoulder
4	Hex collared bolt
5	Hexagon bolt
6	Hexagon head bolt
8	Case
9	Dowel sleeve
10	Hex collared bolt
11	Gearbox mounting
12	Balance weight
13	Hexagon bolt
14	Bracket
15	Balance weight
16	Hex collared bolt
17	Bolt,hex.hd.with shoulder

VOLKSWAGEN TOUAREG (0C8):

- Gearbox, complete, 8-speed automatic gearbox, for four-wheel drive:

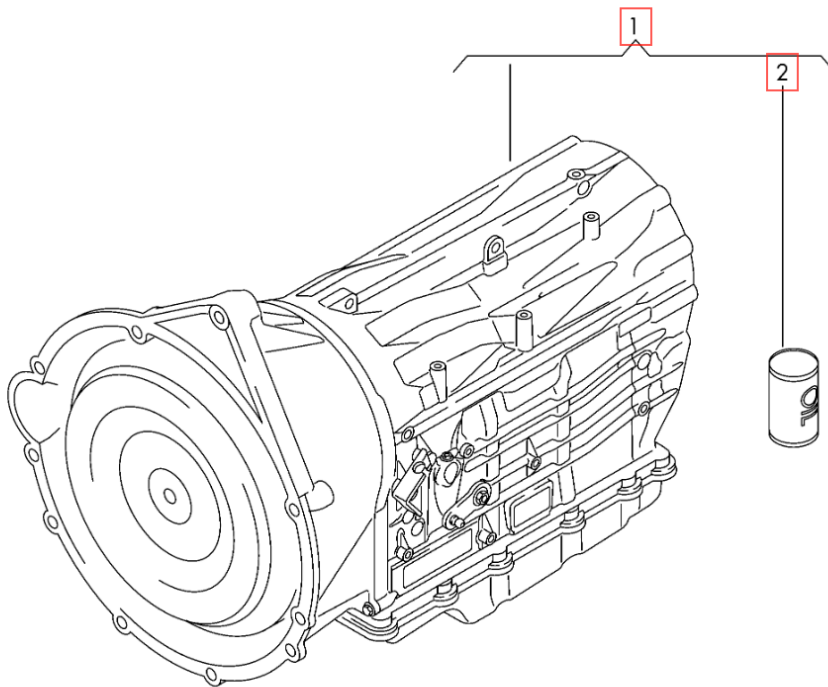

Parts:

N°	Title
1	8-speed automatic gearbox
1A	Transmission Fluid

- Transmission securing parts, 8-speed automatic gearbox, for four-wheel drive:

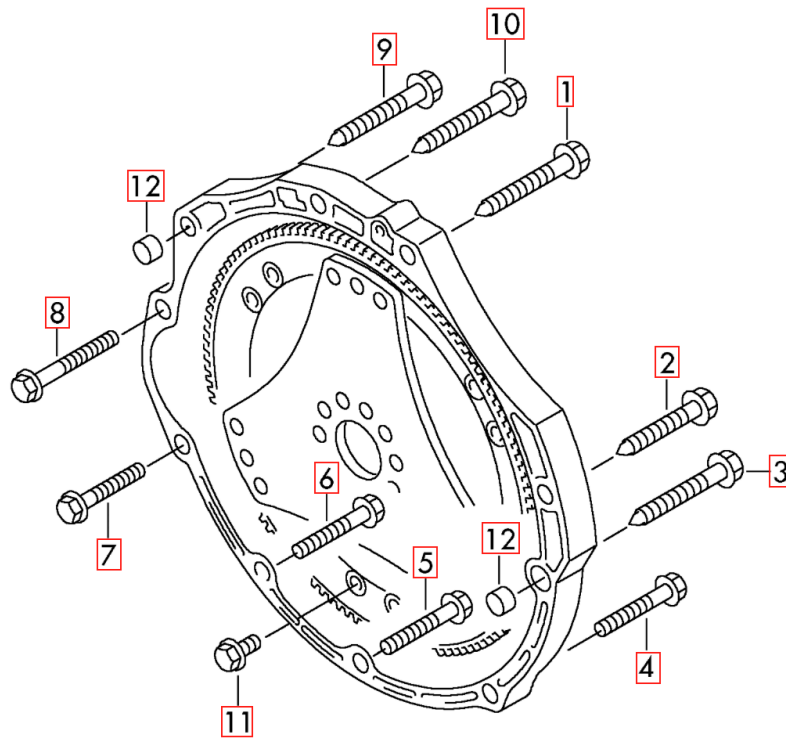

Parts:

N°	Title
1	Hexagon collared bolt with hexagon socket head (duo)
2	Multi-point socket head bolt with collar
3	Hexagon collared bolt with hexagon socket head (duo)
4	Hex collared bolt
5	Hex collared bolt
6	Hex collared bolt
7	Hex collared bolt, for starter
8	Hex collared bolt, for starter
9	Hexagon collared bolt with hexagon socket head (duo)
10	Hexagon collared bolt with hexagon socket head (duo)
11	Socket head bolt with hexagon socket head (combination)
12	Dowel sleeve

- Oil pressure line for gearbox oil cooling, for 8-speed automatic gearbox:

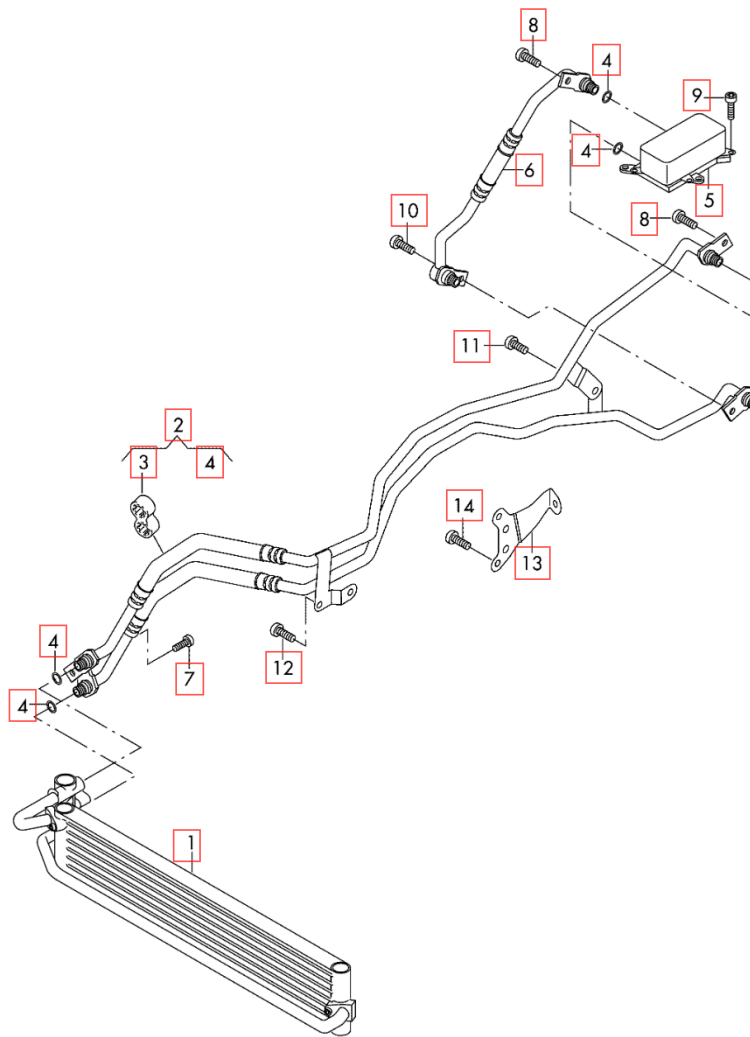

Parts:

N°	Title
1	Gear oil cooler
2	Oil pressure line
3	Protective hose
4	O-ring
5	Atf preheater
6	Oil pressure line
7	Hexagon socket flat head bolt
8	Bolt, hexagon head self-locking
9	Socket head bolt with inner multipoint head
10	Socket head bolt with inner multipoint head
11	Socket head bolt with inner multipoint head
12	Bolt, hexagon head self-locking

13	Spacer holder
14	Socket head bolt with inner multipoint head

- Converter, valve body, for 8-speed automatic gearbox, four-wheel drive:

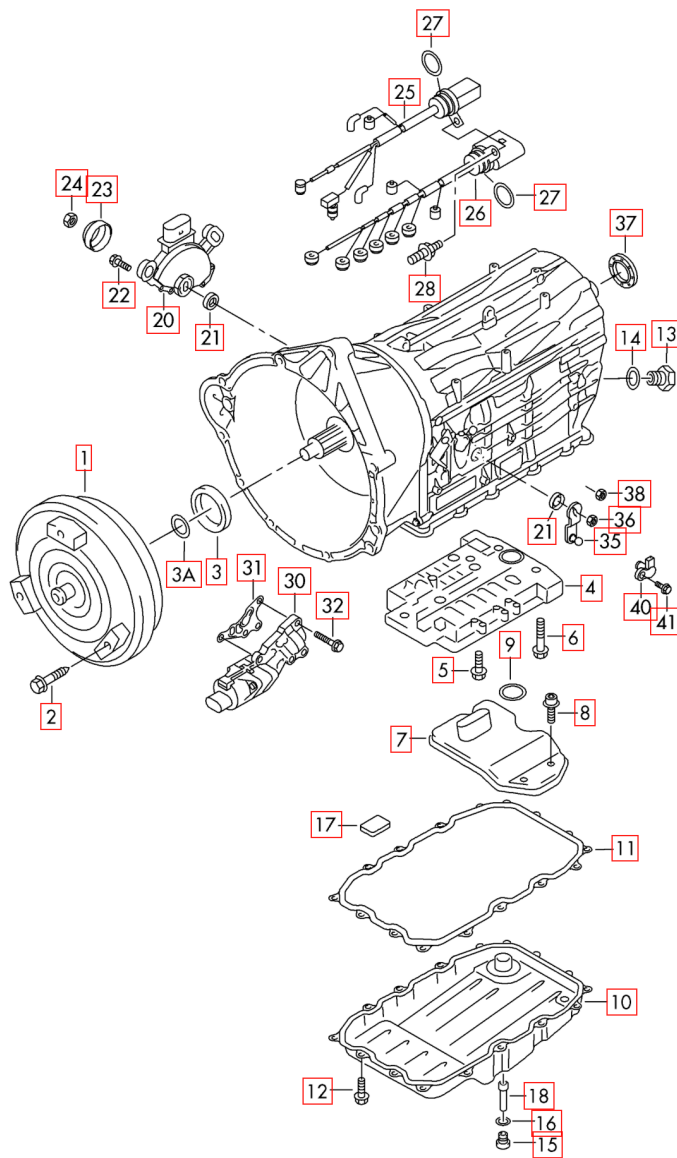

Parts:

N°	Title
1	Converter
2	Socket head bolt with hexagon
3	Shaft oil seal
3A	O-ring
4	Valve body
5	Hex collared bolt
6	Hexagon head bolt
7	Oil strainer

8	Hex collared bolt
9	Seal
10	Transmission oil sump
11	Gasket for oil sump
12	Hexagon head bolt
13	Sealing plug
14	O-ring
15	Drain plug
16	O-ring
17	Magnet
18	Oil pipe
20	Multi-function switch for automatic gearbox
21	Radial shaft seal
22	Hexagon bolt
23	Protective cap
24	Domed cap nut
25	Wiring harness for automatic gearbox
26	Wiring harness for automatic gearbox
27	O-ring
28	Double stud with hexagon drive
30	Oil pump
31	Seal
32	Hex collared bolt
35	Selector lever
36	Hexagon nut
37	Radial shaft seal
38	Securing ring
40	Gearbox speed sender
41	Hexagon head bolt (combi)

- Gear housing, guard plates, for 8-speed automatic gearbox, four-wheel drive:

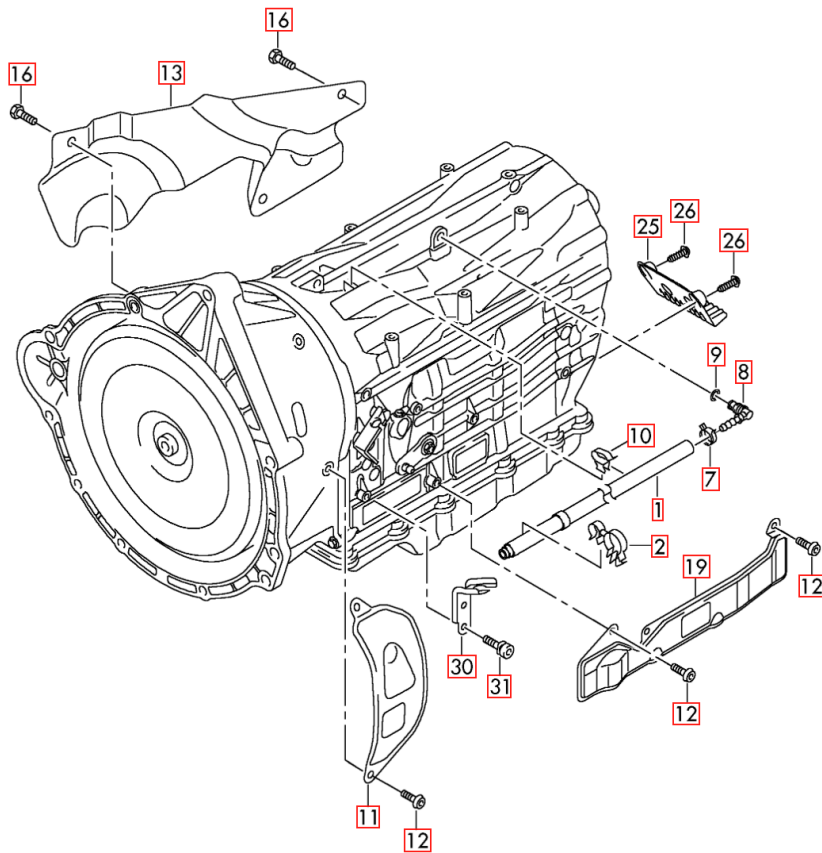

Parts:

N°	Title
1	Breather assy.
2	Bracket for corrugated pipe
7	Clip
8	Angled connector
9	O-ring
10	Clip
11	Guard plate
12	Hexagon socket flat head bolt
13	Guard plate
16	Bolt, hexagon head self-locking
19	Guard plate
25	Guard plate
26	Bolt, hexagon head self-locking
30	Abutment
31	Hex collared bolt

TWO DIFFERENTIAL TYPES:

Self-Locking centre differential:

- Transfer box with self- locking centre differential:

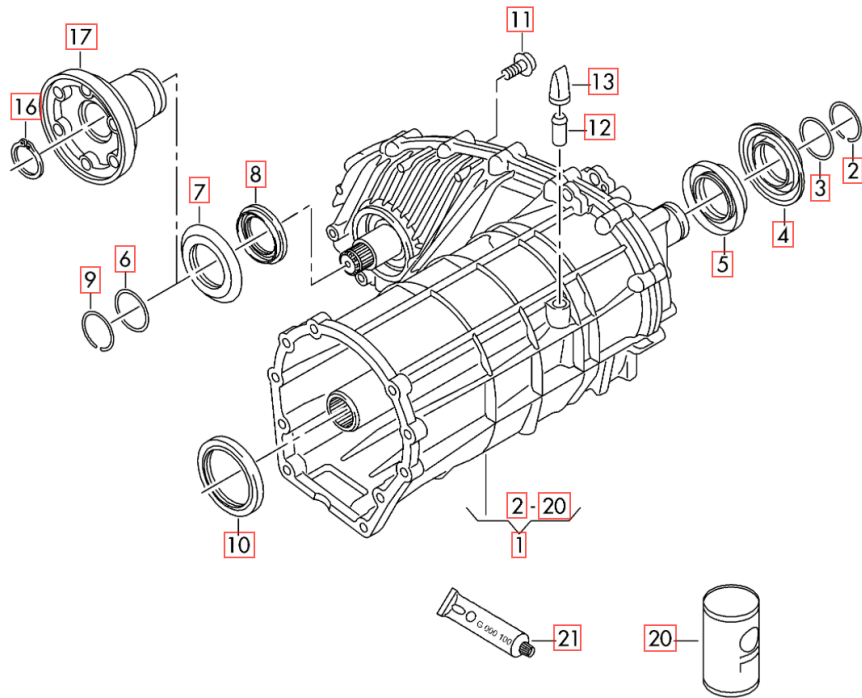

Parts:

N°	Title
1	Transfer box
2	Snap ring
3	O-ring
4	Protective ring
5	Radial shaft seal
6	O-ring
7	Protective ring
8	Radial shaft seal
9	Snap ring
10	Radial shaft seal
11	Sealing plug
12	Sleeve
13	Breather valve
16	Securing ring
17	Flange
20	Transfer box gear oil
21	Grease for clutch plate splines

- Attachment fasteners for transfer gearbox with self- locking centre differential:

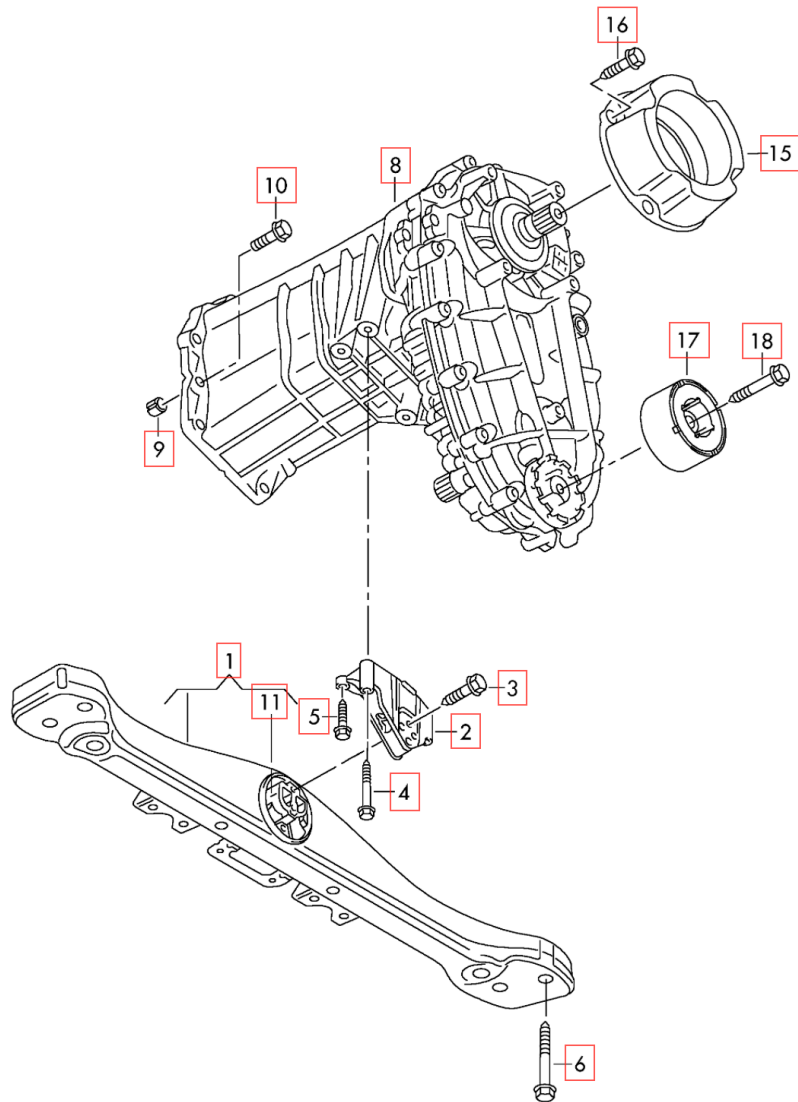

Parts:

N°	Title
1	Transmission carrier
2	Console
3	Bolt, hex. hd. with shoulder, self-locking
4	Hex collared bolt
5	Hexagon bolt
6	Hexagon head bolt (combi)
8	Transfer box, see illustration, item:
9	Dowel sleeve
10	Dodecagonal head bolt
11	Gearbox mounting
15	Balance weight

16	Hex collared bolt
17	Balance weight
18	Bolt,hex.hd.with shoul.(combi)

Electric Locking centre differential:

- Transfer box with electric locking centre differential, with reduction stage:

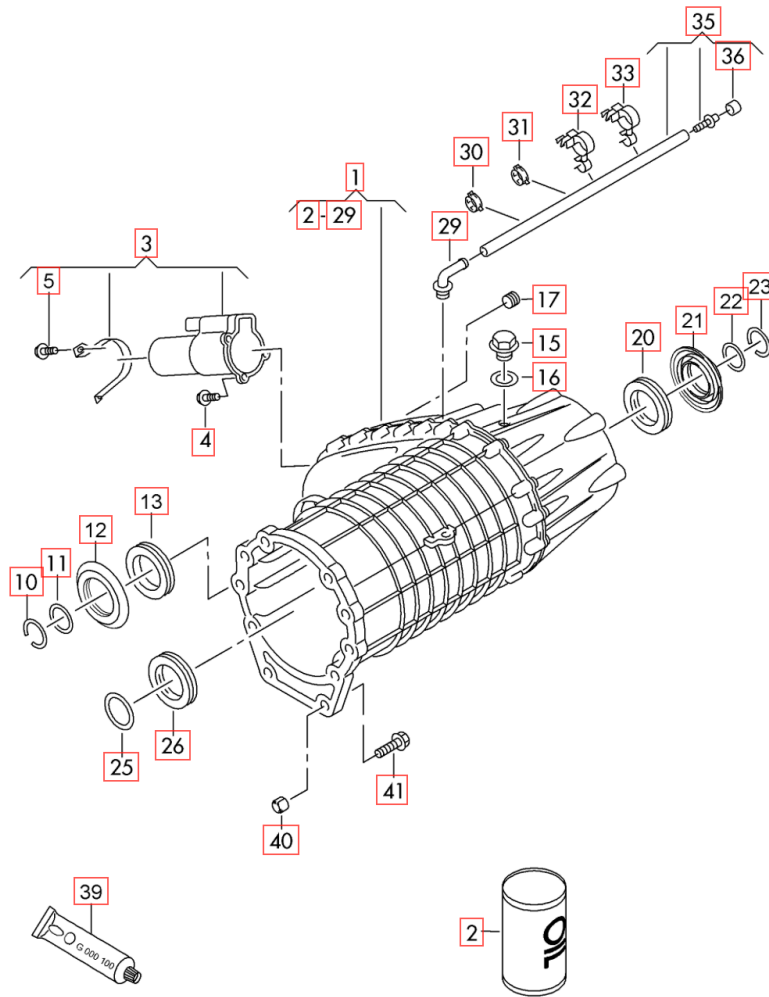

Parts:

N°	Title
1	Transfer box
2	Transfer box gear oil
3	Servomotor
4	Socket head bolt with inner multipoint head
5	Hexagon head bolt
10	Hexagon head bolt
11	O-ring

12	Protective ring
13	Radial shaft seal
15	Sealing plug
16	O-ring
17	Sealing plug
20	Radial shaft seal
21	Protective ring
22	O-ring
23	Snap ring
25	O-ring
26	Radial shaft seal
29	Breather line
30	Clip
32	Double clip
33	Retainer, swivel
35	Breather assy
36	Cap for venting the gearbox
39	Grease for clutch plate splines,
40	Dowel sleeve
41	Hex collared bolt

- Attachment fasteners for transfer gearbox with electrically locking centre differential:

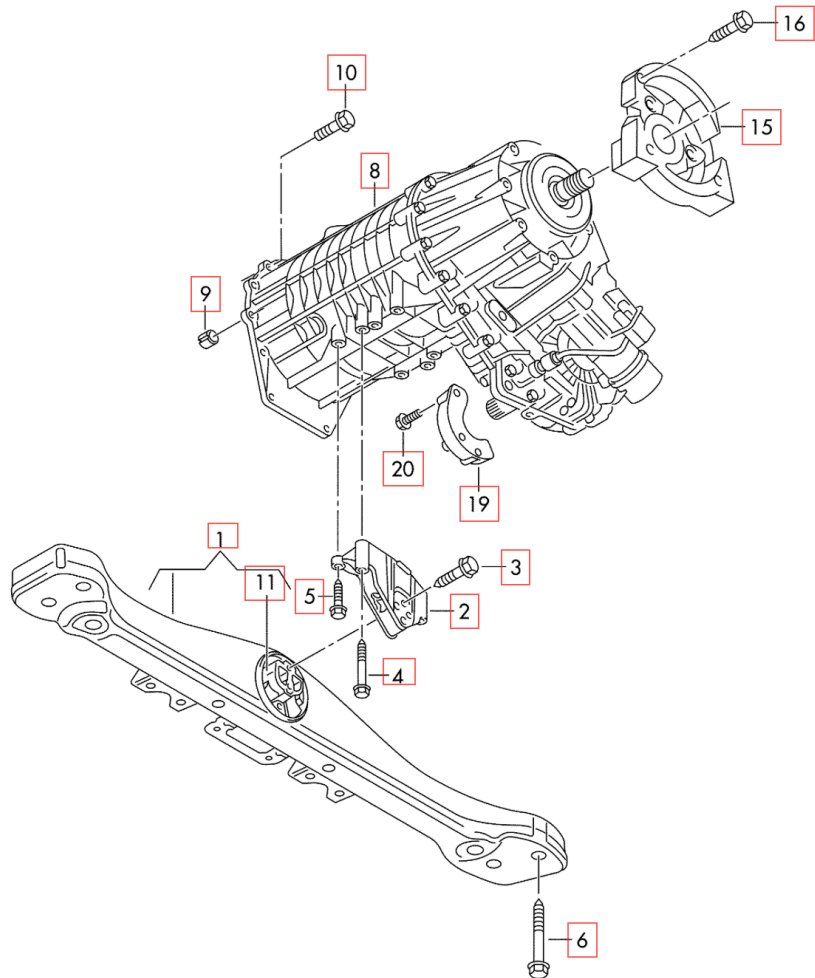

Parts:

N°	Title
1	Transmission carrier
2	Console
3	Bolt, hex. hd. with shoulder
4	Hex collared bolt
5	Hexagon bolt
6	Hexagon head bolt
8	Transfer box (case)
9	Dowel sleeve
10	Dodecagonal head bolt
11	Gearbox mounting
15	Balance weight
16	Hex collared bolt
19	Balance weight
20	Round hd. screw

DEFINITION OF PARTS:

Transmission Fluid:



Automatic transmission fluid (ATF) is the fluid used in vehicles with self-shifting or automatic transmissions. It is typically coloured red or green to distinguish it from motor oil and other fluids in the vehicle.

The fluid is optimized for the special requirements of a transmission, such as valve operation, brake band friction and the torque converter as well as gear lubrication.

ATF is also used as a hydraulic fluid in some power assisted steering systems, as a lubricant in some 4WD transfer cases, and in some modern manual transmissions.

Oil temperature controller:

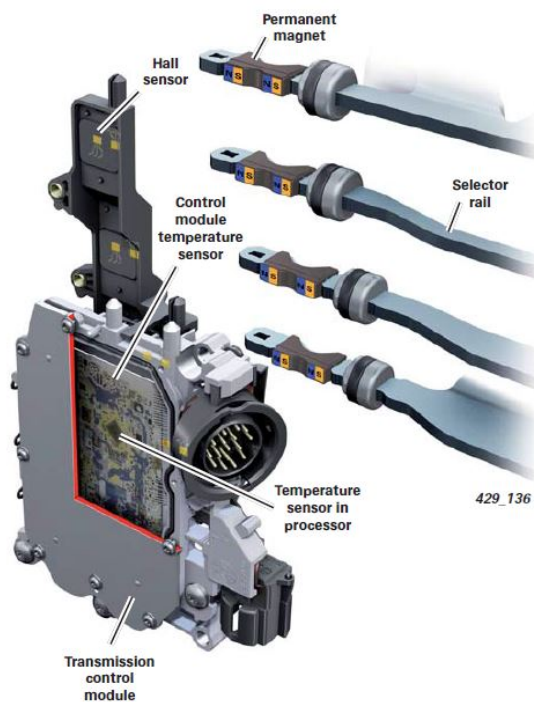

High temperatures have a negative impact on the useful life and performance of electronic components. Due to the integration of the transmission control module into the transmission housing (lubricated by ATF), it is very important to monitor the temperature of both the electronics and ATF. When the temperature reaches approx. 275°F (135°C) (measured by one of the two temperature sensors in the transmission control module), the electronics must be protected against a further rise in temperature. When this threshold value is exceeded, the transmission control module initiates a reduction in engine torque to reduce heat input. Up to a temperature of approx. 293°F (145 °C), engine torque can be reduced gradually until the engine is at idle. When the engine is at idle, the clutches are open and there is no power transmission from the engine to the drive wheels. When the protective function is activated, an entry is made in the fault memory and the following text message is displayed in the instrument cluster: "You can continue driving to a limited extent."

Socket head bolt with hexagon:

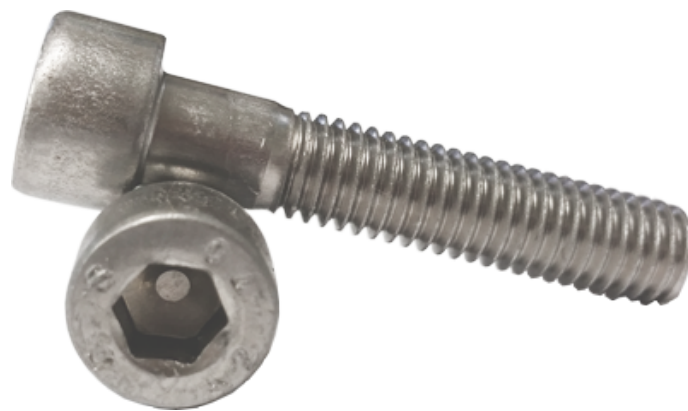

A bolt is a form of threaded fastener with an external male thread. Bolts are thus closely related to, and often confused with, screws.

The distinction between a bolt and a screw is commonly misunderstood. There are several practical differences, but most have some degree of overlap between bolts and screws.

The defining distinction, per Machinery's Handbook, is in their intended purpose: Bolts are for the assembly of two unthreaded components, with the aid of a nut. Screws in contrast are used with components, at least one of which contains its own internal thread, which even may be formed by the installation of the screw itself. Many threaded fasteners can be described as either screws or bolts, depending on how they are used.

Bolts are often used to make a bolted joint. This is a combination of the nut applying an axial clamping force and also the shank of the bolt acting as a dowel, pinning the joint against sideways shear forces. For this reason, many bolts have a plain unthreaded shank (called the grip length) as this makes for a better, stronger dowel.

Magnet:



Automatic Transmission Oil Pan Magnets are placed in the transmission oil pan and are designed to capture small pieces of metal before they can plug the transmission oil filter or damage the transmission.

Selector lever:

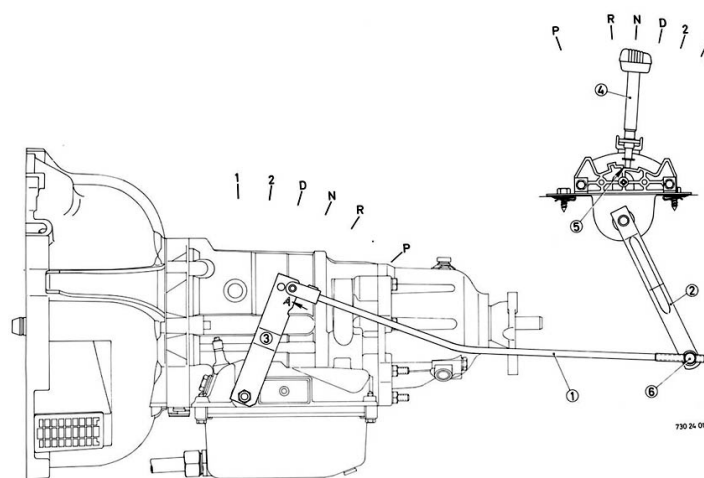

Conventionally, in order to select the transmission operating mode, the driver moves a selection lever located either on the steering column or on the floor (as with a manual on the floor, except that automatic selectors on the floor do not move in the same type of pattern as manual levers do). In order to select modes, or to manually select specific gear ratios, the driver must push a button in (called the shift-lock button) or pull the handle (only on column mounted shifters) out. Some vehicles position selector buttons for each mode on the cockpit instead, freeing up space on the central console.

Needle bearing:

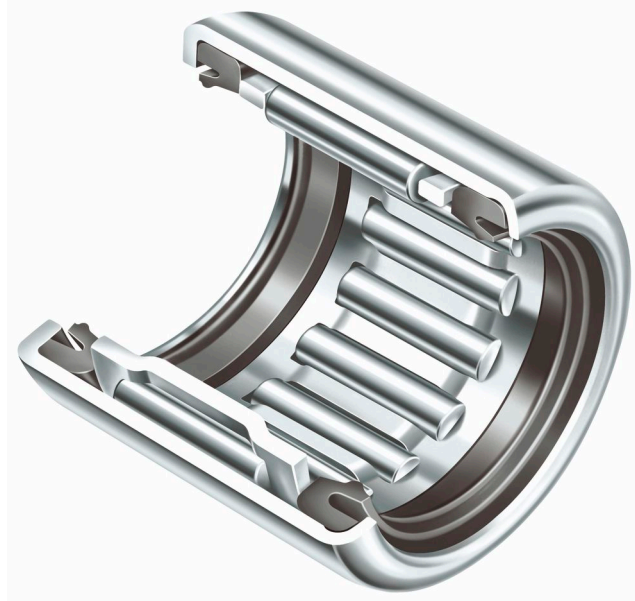

A needle roller bearing is a special type of roller bearing which uses long, thin cylindrical rollers resembling needles. Ordinary roller bearings' rollers are only slightly longer than their diameter, but needle bearings typically have rollers that are at least four times longer than their diameter. Like all bearings, they are used to reduce the friction of a rotating surface. Compared to ball bearings and ordinary roller bearings, needle bearings have a greater surface area in contact with the races, so they can support a greater load. They are also thinner, so they require less clearance between the axle and the surrounding structure. Needle bearings are heavily used in automobile components such as rocker arm pivots, pumps, compressors, and transmissions. The drive shaft of a rear-wheel drive vehicle typically has at least eight needle bearings (four in each U joint) and often more if it is particularly long, or operates on steep slopes.

Console:



This element permits to the driver to select the position of the automatic transmission, furthermore, the driver can shift up and down at will by toggling the (console mounted) shift lever similar to a semi-automatic transmission.

Snap ring:



IPN-U162860-678

info@cobratransmission.com • 1-800-293-1848

A circular spring, having a small break in its circumference, used as a fastener; a circlip.

Round hd. Screw:



Head for a screw or bolt with rounded top surface and flat lower surface. Holds screw or bolt to surface of an object. Designed into the screw or bolt. Can have various sizes and drive types.

Transfer box:

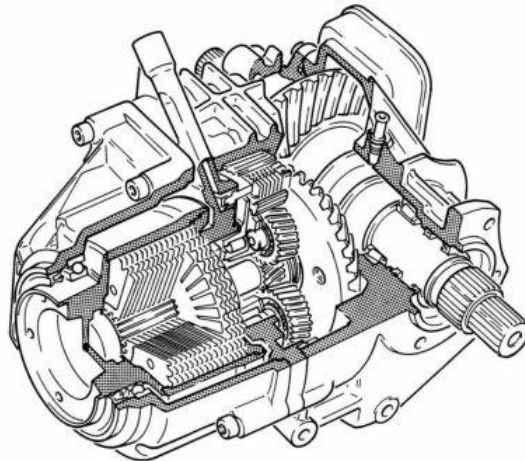

A transfer box or a transfer case is a part of the drivetrain of four-wheel-drive, all-wheel-drive, and other multiple powered axle vehicles. The transfer case transfers power from the transmission to the front and rear axles by means of drive shafts. It also synchronizes the difference between the rotation of the front and rear wheels, and may contain one or more sets of low range gears for off-road use.

O-ring:



An O-ring, also known as a packing, or a toric joint, is a mechanical gasket in the shape of a torus; it is a loop of elastomer with a round cross-section, designed to be seated in a groove and compressed during assembly between two or more parts, creating a seal at the interface. The O-ring may be used in static applications or in dynamic applications where there is relative motion between the parts and the O-ring. Dynamic examples include rotating pump shafts and hydraulic cylinder pistons.

O-rings are one of the most common seals used in machine design because they are inexpensive, easy to make, and reliable and have simple mounting requirements. They can seal tens of megapascals (thousands of psi) of pressure.

Radial shaft seal:

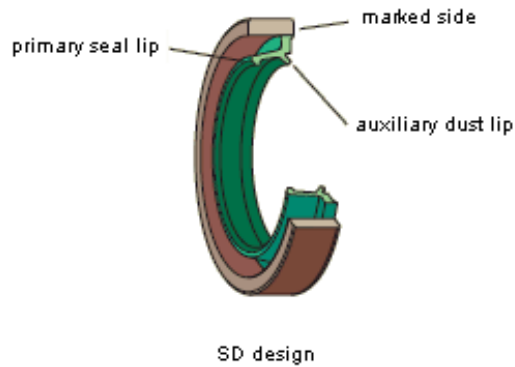

Radial shaft seals, also known as lip seals, are used to seal rotary elements, such as a shaft or rotating bore. Common examples include strut seals, hydraulic pump seals, axle seals, power steering seals, and valve stem seals. Early radial shaft seals utilized rawhide as the sealing element, and many elastomeric seal companies today once were tanneries. The advent of modern elastomers replaced rawhide, industry also added a garter spring which helps the sealing lip compensate for lip wear and elastomer material changes. The seal construction will consist of a sprung main sealing lip which has a point contact with the shaft. The point contact is formed by two angles, with the air side angle usually less than the oil side angle. Depending on the seal type these two angles are varied to create a pressure distribution at the seal contact point which has a steeper slope on the oil side of the seal. The shallower the slope on the oil side of the seal the wetter the seal will run. The spring is positioned such that axially the centerline of the spring is biased to the air side of the lip contact point.

Double stud with hexagon drive:



One type of bolt used in the VW group.

Cover cap:



A cap to cover some holes of the gearbox case.

Input shaft:



The input shaft brings the engine drive into the gearbox system and when a gear is engaged it withstands the torque generated and transmitted to the output shaft. Steel forging for input shafts allows the variety of shapes and fatigue resistance needed to ensure reliable transmission systems.

Output shaft:



The output shaft of the gearbox is the shaft that is connected to the drive wheels and it turns at a speed determined by the gear you have selected. In the lower gears this speed will be lower than the input shaft's speed to allow the engine to be running at an efficient speed

while the driven wheels are turning at a manageable speed. In top gear however, the output shaft will be turning at close to the input shaft's speed.

Bolt, hex. hd. with shoulder:



Shoulder bolts are screws with an unthreaded shoulder that is larger in diameter than the threads. Also known as stripper bolts.

Grease for clutch plate splines:



Grease used to lubricate the clutch plate.

Front axle differential:



A differential is a gear train with three shafts that has the property that the angular velocity of one shaft is the average of the angular velocities of the others, or a fixed multiple of that average.

Oval hexagon socket head bolt:



©2013 VW AUTOMOTIVE®

One kind of bolt of the VW group.

Valve body:

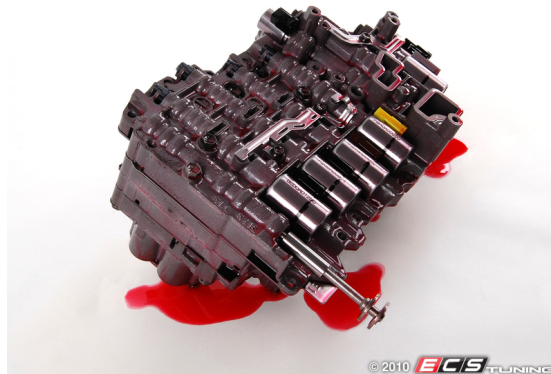

You will find this valve body on the front of the transmission block facing the radiator, under the side pan.

The valve body is the hydraulic control center that receives pressurized fluid from the main pump operated by the fluid coupling/torque converter. The pressure coming from this pump is regulated and used to run a network of spring-loaded valves, check balls and servo pistons. The valves use the pump pressure and the pressure from a centrifugal governor on the output side (as well as hydraulic signals from the range selector valves and the throttle valve or modulator) to control which ratio is selected on the gearset; as the vehicle and engine change speed, the difference between the pressures changes, causing different sets of valves to open and close. The hydraulic pressure controlled by these valves drives the various clutch and brake band actuators, thereby controlling the operation of the planetary gearset to select the optimum gear ratio for the current operating conditions. However, in many modern automatic transmissions, the valves are controlled by electro-mechanical servos which are controlled by the electronic engine control unit (ECU) or a separate transmission control unit (TCU, also known as transmission control module (TCM)).

Multi-function switch for automatic gearbox:



The multifunction switch (multifunction transmission range switch) is on the left side of the TIP transmission. When you select different gears the multifunction switch tells the transmission control module what gear you are in. The control module receives feedback from the switch (4 pins) and can determine if the switch is bad. The control module will then put the transmission in a limp mode to protect the transmission.

Protective ring:



A rubber ring to secure the flange of the transfer box.

Grooved ball bearing:



A ball bearing is a type of rolling-element bearing that uses balls to maintain the separation between the bearing races.

The purpose of a ball bearing is to reduce rotational friction and support radial and axial loads. It achieves this by using at least two races to contain the balls and transmit the loads through the balls. In most applications, one race is stationary and the other is attached to the rotating assembly (e.g., a hub or shaft). As one of the bearing races rotates it causes the balls to rotate as well. Because the balls are rolling they have a much lower coefficient of friction than if two flat surfaces were sliding against each other.

Ball bearings tend to have lower load capacity for their size than other kinds of rolling-element bearings due to the smaller contact area between the balls and races. However, they can tolerate some misalignment of the inner and outer races.

Balance weight:



This piece is used to reduce vibrations on the gearbox.

Transfer box gear oil:



The liquid necessary for the transfer box to work properly.

Rear axle differential:



It works in the same way than the front axle, with an open differential.

Retaining washer:

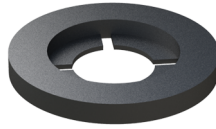

A retaining washer or ring is a fastener that holds components or assemblies onto a shaft or in a housing/bore when installed in a groove. Once installed, the exposed portion acts as a shoulder which retains the specific component or assembly. Circlips are a type of retaining ring.

Self-locking retaining rings may be installed in applications where there is no groove.

Retaining rings are typically made from carbon steel, stainless steel or beryllium copper and may feature a variety of finishes for corrosion protection depending on the type of environment in which they are used.

Oil pressure switch:



The automatic transmission will have pressure switches that activate a system to engage a gear or gear set. When the vehicle wants second gear, the computer will activate the pressure switch to allow hydraulic pressure to clamp down on the second gear set so the vehicle can shift to second gear. When these switches fail, a fault code may be stored and you may notice the vehicle does not operate properly.

Domed cap nut:

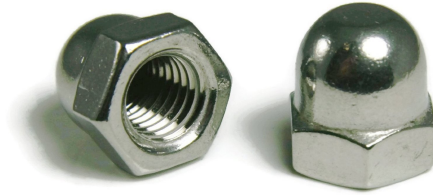

The acorn nut is a type of fastener which gets its name from its shape. Acorn nut is its common name and it is also called a crown hex nut, blind nut, cap nut or domed cap nut. It is a nut that has a domed top to cover the threads. This is to prevent contact with the external thread to protect the threads or protect other things the threads would rub against. In addition the dome gives a more finished appearance. It is usually made of brass, steel, stainless steel (low carbon content) or nylon. It can also be chrome plated and given a mirror finish.

Flange:



A flange is an external or internal ridge, or rim (lip), for strength, as the flange of an iron beam such as an I-beam or a T-beam; or for attachment to another object, as the flange on the end of a pipe, steam cylinder, etc., or on the lens mount of a camera; or for a flange of a rail car or tram wheel. Thus flanged wheels are wheels with a flange on one side to keep the wheels from running off the rails. The term "flange" is also used for a kind of tool used to form flanges.

Centre differential:



The self-locking center differential is configured as a planetary gear. An internal gear encloses a sun gear; rotating between these two elements are roller-shaped planet gears connected to a rotating housing. They distribute the torque asymmetrically – the somewhat larger fraction flows to the rear via the internal gear, which has a larger diameter, and the output shaft connected to it. The smaller fraction is transferred to the smaller sun gear, from where it is sent to the front axle.

If traction at one of the axles declines, the helical form of the gears and their oblique splines produce axial forces in the differential. These forces act on the friction disks to provide the desired locking torque and to divert the power to the wheels with the better friction values.

Atf preheater:



The ATF pre-heater consists of a set of plates soldered together to form a heat exchanger through which coolant and ATF flow. In a very tight installation space, this leads to a relatively large heat transfer area, by means of which the coolant's heat is transferred to the ATF.

Dodecagonal head bolt:



Other kind of bolts used in the transfer box.

Oil strainer:



An oil filter is a filter designed to remove contaminants from engine oil, transmission oil, lubricating oil, or hydraulic oil. Oil filters are used in many different types of hydraulic machinery. A chief use of the oil filter is in internal-combustion engines in on- and off-road motor vehicles, light aircraft, and various naval vessels. Other vehicle hydraulic systems, such as those in automatic transmissions and power steering, are often equipped with an oil filter.

Breather assy:

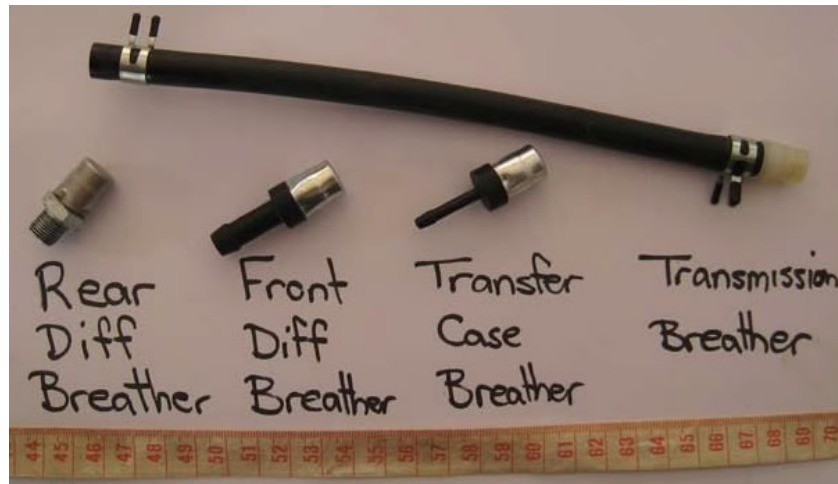

Breathers are extremely important in transmission preventive maintenance. If breathers become plugged and temperatures dip down during the evening, the cab becomes a vacuum because the cool air inside the cab shrinks. As the air inside the cab shrinks it draws in air, dirt and other contaminants through the gaskets and seals. If this occurs regularly, the gaskets and seals may sustain enough damage to allow water and other contaminants into the cab. Dirt and water are especially harmful to the electronics. Solenoids in your electronics control when and how quickly your clutches engage. When the solenoids become contaminated they become sluggish and your clutches may engage too quickly or they may slide.

Securing ring:



Similar to a retaining washer, it holds components or assemblies onto a shaft or in a housing/bore when installed in a groove.

Sleeves, centre sleeve and dowel sleeve:



A replaceable cylinder liner or tube, it is made of a pipe-like section that is either pressed or pushed into the block. If the cylinder cannot be re-bored to an oversize or if the liner has been damaged beyond repair, the cylinder may be re-sleeved. It is used in the joints of the transfer box.

Spacer holder:



Small steel plate that separates and holds the oil pressure lines.

Bolt, hex. hd. with shoulder, self-locking:



Self-Locking Bolts are bolts of any shape head that has a nylon patch or pellet inserted in the thread to prevent coming loose due to vibrations.

Multi-point socket head bolt with collar:



2012 | © | C. S. F. L. A. N. C. S.

This bolt is used to secure the front axle to the transmission.

Seal:



A seal for the oil strainer.

Bracket:

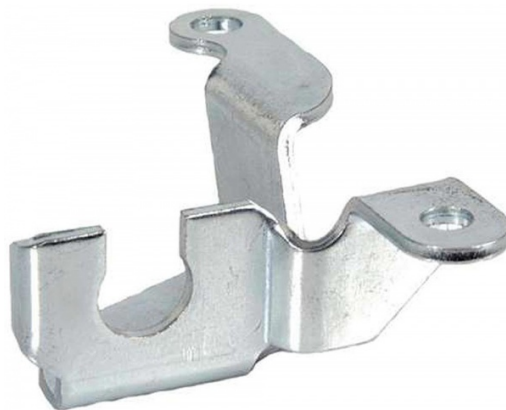

For support the transfer box to the transmission carrier.

Thrust washer:



Thrust washers are used as a bearing surface for rotary applications. They are usually made of steel, bronze, plastic, or other materials with low friction coefficients. Thrust washers, sometimes called rotary thrust washers, are washers designed to prevent movement along the axis of a shaft.

Thrust bearings support an axial load on a shaft. A thrust bearing can be a plate at the end of a shaft, or a device against which a collar on the shaft presses. Banded thrust bearings and washers are reinforced by a band encircling the outer edge.

Oil drip tray:

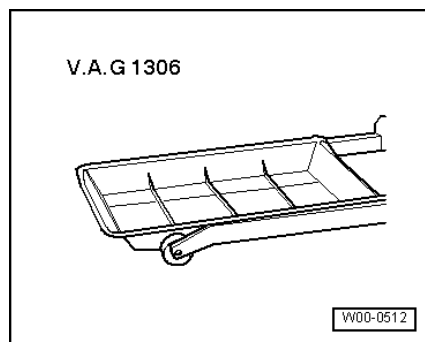

To collect the leftover oil of the centre differential.

Servomotor:



A servomotor is a rotary actuator or linear actuator that allows for precise control of angular or linear position, velocity and acceleration. It consists of a suitable motor coupled to a sensor for position feedback. It also requires a relatively sophisticated controller, often a dedicated module designed specifically for use with servomotors.

Servomotors are not a specific class of motor although the term servomotor is often used to refer to a motor suitable for use in a closed-loop control system.

Specifically this servomotor is used to control the electric locking centre differential of the transfer box.

Washer:



A washer is a thin plate (typically disk-shaped) with a hole (typically in the middle) that is normally used to distribute the load of a threaded fastener, such as a screw or nut. Other uses are as a spacer, spring (belleville washer, wave washer), wear pad, preload indicating device, locking device, and to reduce vibration (rubber washer). Washers usually have an outer diameter (OD) about twice larger than their inner diameter (ID).

Washers are usually metal or plastic. High-quality bolted joints require hardened steel washers to prevent the loss of pre-load due to Brinelling after the torque is applied.

Transmission oil sump:



Your transmission requires ATF (Automatic Transmission Fluid) in order to provide necessary fluid pressure, lubrication, and cooling capabilities. Other functions include cleaning metal surfaces, preventing rust, extending temperature range, preventing fluid oxidation, and conditioning gaskets. But all of that ATF has to be held somewhere though, which is exactly what the transmission pan is for. Besides holding ATF, they are also meant to:

- Protect the ATF from foreign contaminants
- Collect any dirt or particles in the ATF through the pan's magnet
- Prevent objects on the road such as rocks from springing a leak
- Help cool the ATF before it goes back into the transmission
- The transmission pan gasket prevents any fluid from leaking out

Cap for venting the gearbox:



Gearboxes, pumps and reservoirs have to “breathe” when the air expands and contracts, as well as when incoming fluid displaces air, or when air is drawn in when hydraulic components activate. The simple solution to these problems is the use of desiccant breathers, which can stop water and particulates from contaminating the lubricant in the first place.

Silicone sealant:



To seal the transfer box for prevent it of leakage.

Wiring harness for automatic gearbox:



The transmission wiring harness is one of the most critical components within today's complicated electronically controlled units. Electronic signals control nearly every function within the transmission. The wire harness conveys these signals to the solenoids and sensors. Any interruption will result in failure.

Breather line:



The line that permits the cap for venting of the transmission to breath.

Guard plate:



That allows elements of the gearbox to be safe from possible impacts

Gasket for oil sump:



A *gasket for oil sump* is a *gasket* that sits between the transmission oil sump and the back of the transmission in gearbox. Its purpose is to *seal* the joint to ensure that there are no leaks.

Ventilation union:



The part that is at the sides of the breather line and connects the plastic tube.

Breather valve:



Gearbox breathers are a first line of defense against airborne contaminants. The devices let the gearbox take in air as it cools while filtering water vapor and solid contaminants before they enter the fluid system. When gearboxes warm up, breathers should let air escape while keeping oil mist and splash inside. When a breather blocks up, the pressure differentials in a warming gearbox can push oil out its labyrinth seals and onto nacelle floors.

Oil pump:

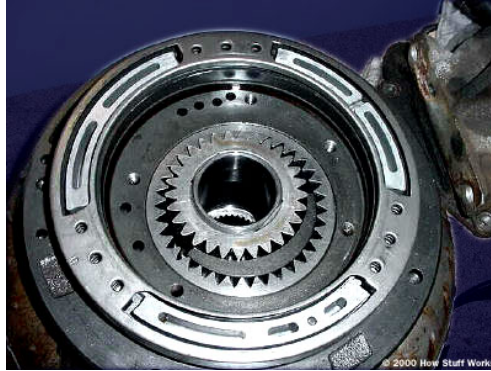

Automatic transmissions have a neat pump, called a gear pump. The pump is usually located in the cover of the transmission. It draws fluid from a sump in the bottom of the transmission and feeds it to the hydraulic system. It also feeds the transmission cooler and the torque converter.

The inner gear of the pump hooks up to the housing of the torque converter, so it spins at the same speed as the engine. The outer gear is turned by the inner gear, and as the gears rotate, fluid is drawn up from the sump on one side of the crescent and forced out into the hydraulic system on the other side.

Gear oil cooler:



The water/coolant mixture that flows through the radiator, transfers heat from the cylinders, engine block, heads, and intake manifold to the cooler air flowing past the radiator tubes from the outside.

Engine oil does its part, too, as it's constantly pumped over and around bearings, lifters, gears, chains, camshaft, crankshaft, connecting rods and pistons. On high-performance engines and most turbo-diesels, small "jets" spray oil at the bottoms of the pistons to remove heat from these heavily-stressed areas.

An automatic transmission also generates heat from friction between gears and clutch packs and shear loads in the torque converter. The heavier the load, the more friction and heat is generated.

Transmission fluid (oil) handles that cooling task as it circulates to the transmission cooler, which in most instances sits in front of the radiator. That cooler positioning is because transmission fluid temperatures are the most critical of all the fluids.

Protective hose:



To protect the oil pressure line of breakages.

Sealing plug:



For sealing the back part of the transfer box.

Clip:



A retainer clip to sustain air or oil lines.

Chain sprocket:



A sprocket or sprocket-wheel is a profiled wheel with teeth, or cogs, that mesh with a chain, track or other perforated or indented material. The name 'sprocket' applies generally to any wheel upon which radial projections engage a chain passing over it. It is distinguished from a gear in that sprockets are never meshed together directly, and differs from a pulley in that sprockets have teeth and pulleys are smooth.

Sprockets are used in bicycles, motorcycles, cars, tracked vehicles, and other machinery either to transmit rotary motion between two shafts where gears are unsuitable or to impart linear motion to a track, tape etc.

Gearbox speed sender:



The transmission speed sensors are used to calculate the actual gear ratio of the transmission while in use. There are generally two speed sensors that work in conjunction to provide accurate transmission data to the vehicle's powertrain control module. The first is known as the input shaft speed (ISS) sensor. As described, this sensor is used to monitor the speed of the transmission's input shaft. The other sensor is the output shaft speed (OSS) sensor. If either of these two sensors falls out of alignment or experiences electrical issues, it impacts the operation of the entire transmission.

Double clip or swivel retainer:

Size 2.6" x 1.3"



A double retainer for more than one tube.

Oil pressure line:



The line that allows the oil to pass through for cooling the gearbox.

Converter:



A torque converter is a type of fluid coupling that is used to transfer rotating power from a prime mover, such as an internal combustion engine, to a rotating driven load. The torque converter normally takes place of a mechanical clutch in a vehicle with an automatic transmission, allowing the load to be separated from the power source. It is usually located between the engine's flexplate and the transmission.

The key characteristic of a torque converter is its ability to multiply torque when the output rotational speed is so low as to allow the fluid coming off the curved vanes of the turbine to be deflected off the stator while it is locked against its one-way clutch, thus providing the equivalent of a reduction gear. This is a feature beyond that of the simple fluid coupling, which can match rotational speed but does not multiply torque, thus reduces power.

Some of these devices are also equipped with a "lockup" mechanism which rigidly binds the engine to the transmission when their speeds are nearly equal, to avoid slippage and a resulting loss of efficiency.

Drain plug:

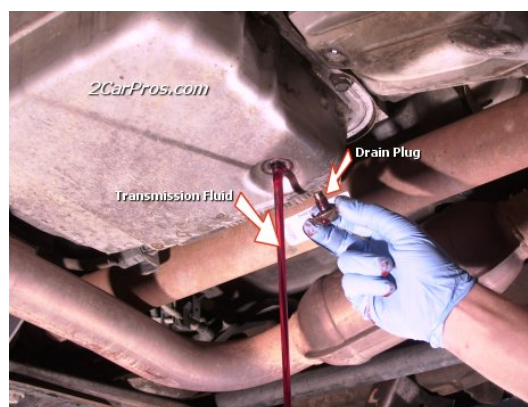

A drain plug is a plug which is taken out to allow a fluid to be drained from a tank such as an engine oil pan or sump.

Angled connector:



As the name says it's a connector that is made for connect two tubes with an angle of 90 degrees.

Drive chain:



Chain-driven transfer cases use a chain to drive most often only one axle, but can drive both axles. Chain-driven transfer cases are quieter and lighter than gear-driven ones. They are used in vehicles such as compact trucks, full size trucks, Jeeps and SUVs. Some off-road driving enthusiasts modify their vehicles to use gear-driven transfer cases, accepting the additional weight and noise to gain the extra strength they generally provide.

Transmission carrier:

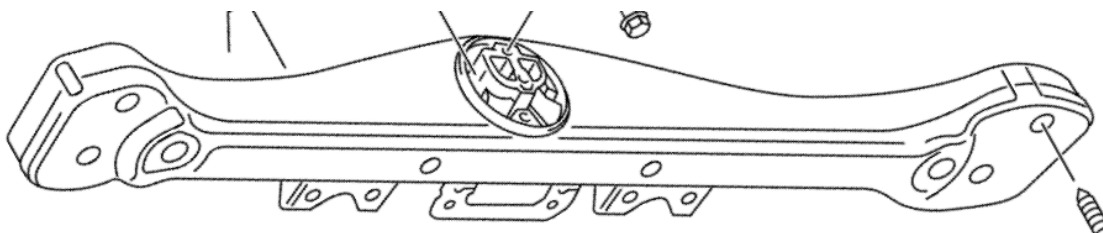

The steel bar that supports the weight of the transmission.

Abutment:



Small bent metal plate to sustain the breather to the gearbox.

Nut:



A nut is a type of fastener with a threaded hole. Nuts are almost always used in conjunction with a mating bolt to fasten multiple parts together. The two partners are kept together by a combination of their threads' friction (with slight elastic deformation), a slight stretching of the bolt, and compression of the parts to be held together.

COMPARISON BETWEEN THE TWO GEARBOXES:

- 09D Technical data:

Specifications	
Developer/Manufacturer	AISIN AW CO. LTD Japan
Designations	Manufacturer: TR-60SN Audi AG: AL750-6Q Service: 09D
Transmission Type	Electro-hydraulically Controlled Six-Speed Planetary Gear (step automatic transmission) with a Planetary Gear Set Concept Based on the Lepelletier Principle. Hydro-dynamic Torque Converter with Slip-Controlled Lockup Clutch. Designed for Longitudinal Installation in Combination with a Transfer Case
Control	Hydraulic Control Module (valve assembly) in the Oil Sump with External Electronic Control Module. Dynamic Shift Program (DSP) with Separate Sport Program in "Position S" and Tiptronic Shift Program for Manual Gear Shifting (optionally available with Tiptronic steering wheel). Special Feature: in Tiptronic Mode, it is Possible to Start in Second Gear.
Maximum Torque	553.1 lb ft (750 Nm) Depending on Type
Ratios: Planetary Transmission	1st Gear 4.148 2nd Gear 2.370 3rd Gear 1.556 4th Gear 1.155 5th Gear 0.859 6th Gear 0.686 R Gear 3.394
Spread	6.05
ATF Specification	Refer to ETKA
ATF Service	Approximately 9.5 qt (9.0 L) (new filling) Lifetime Filling
Weight	Between 213.8 - 242.5 lb (97 - 110 kg)
Limp-Home Capability	3rd Gear and R Gear

- 0C8 Technical data:

Technical data

Developer/manufacturer	AISIN AW CO. LTD Japan
Designation	Automatic gearbox 0C8
Gearbox features	Electrohydraulically controlled 8-speed planetary gearbox with a single primary planetary gear set and a downstream Ravigneaux planetary gear set as a secondary planetary gear set (planetary gearbox concept according to Lepelletier) Hydrodynamic torque converter with slip-controlled torque converter lock-up clutch Design for longitudinal mounting in combination with a transfer box
Control system	Hydraulic control unit (valve chest) in the sump with an external electronic control unit Dynamic shift program DSP with separate sports programme in "position S" and the "Tiptronic" shift programme for changing gear manually Special feature: Starting off in 2nd gear is possible in Tiptronic mode
Torque	Depending on version, up to 1000Nm
Achievement of top speed	Depending on the engine, in either 6th or 7th gear
Spread	7.17 to 7.25
ATF service	ATF: Refer to ELSA for service intervals
Weight	Depending on gearbox adaptation to the engine, between 91kg and 108kg
Emergency operation characteristics	In the case of faults which arise during vehicle operation: in gears 1-4 = 3rd gear in gears 5-8 = 7th gear as of restarting the vehicle, 3rd gear and reverse gear only

The 6 speed gearbox:

The 09D Six-Speed Automatic Transmission in the Audi Q7 unlike the Audi longitudinal AWD configurations where the front axle differential and transfer case are integrated with the transmission, the 09D six-speed automatic transmission in the Audi Q7 is designed as an independent component. The powertrain of the Audi Q7 has a modular configuration. This means that the various subassemblies – the transmission, the front axle differential, and the transfer case – are separate units.





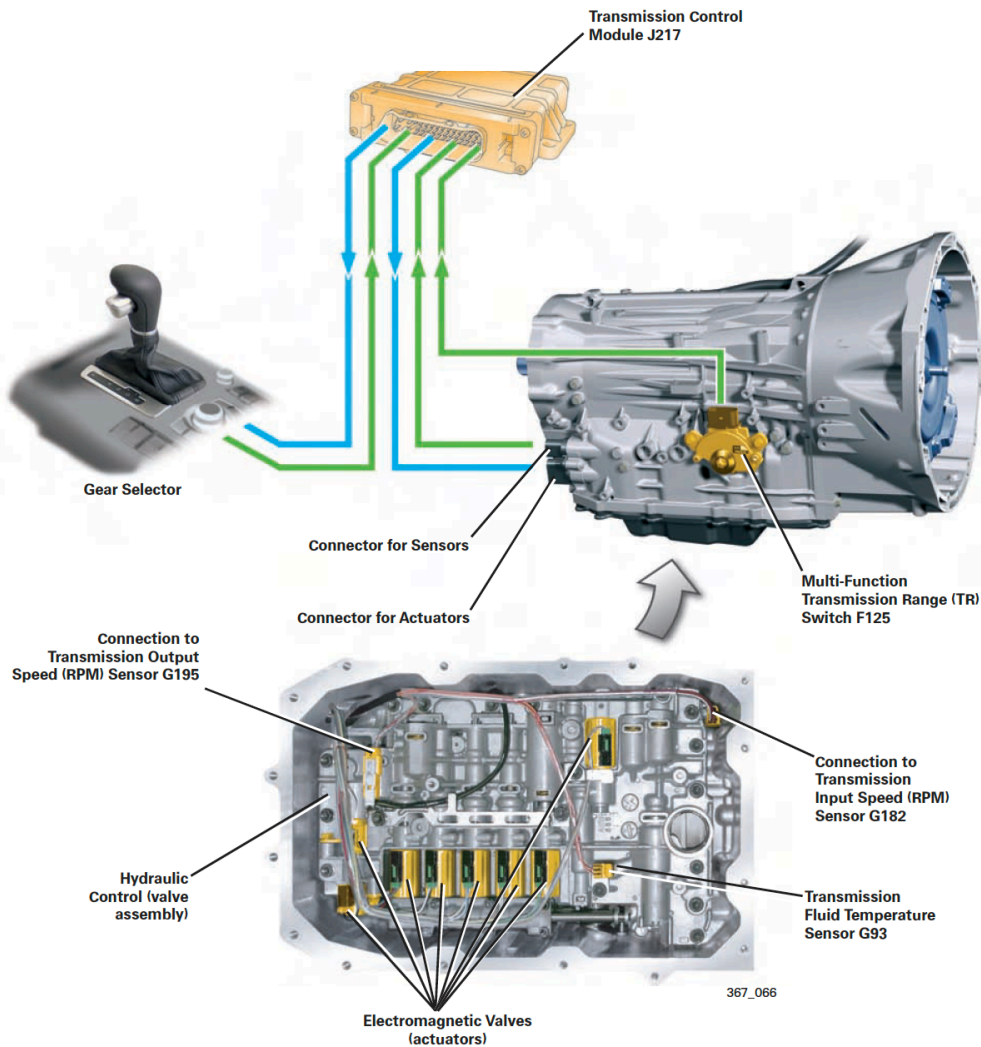



Special Features Designed for Off-Road Use:

- A special low ATF pick-up point and a high ATF capacity ensure reliable oil intake in rough terrain.
- A large ATF cooler maintains the ATF temperature at a safe level.
- The elevated transmission breather hose prevents ingress of water into the transmission, even under adverse conditions.
- A large torque converter with lockup clutch reduces heat build-up in the ATF and allows power to be transmitted directly.



Bottom View of the Transmission – Looking at the Hydraulic Control (valve assembly)

Legend to Sectional View of Transmission

	Hydraulic Parts, Hydraulic Control, ATF		Plastics, Seals, Rubber, and Washers
	Components of Planetary Gear Sets		Components of Shift Elements Cylinders, Pistons, and Air Sensor Plates
	Shafts and Gears		Housings, Screws, and Bolts
	Multi-Plate Clutches, Bearings, Washers, and Circlips		Electrical Components

09D gearbox

In the 09D and 0C8 transmission, torque is transmitted from the engine to the transmission by a hydro-dynamic torque converter with slip-controlled lockup clutch.

The 09D transmission is designed as an independent component, without the usual integrated transfer case and front axle differential.

The 8-speed automatic gearbox was introduced for the first time at Volkswagen in the Touareg 2011. The 8-speed automatic gearbox 0C8 is a further development of the 6-speed automatic gearbox 09D from the Japanese gearbox company AISIN AW CO LTD. Together with the extensive know-how provided by the Volkswagen engineers, success has been achieved in adapting the gearbox to the Volkswagen technologies' increased requirements.

Thanks to the eight forward gears and the closer gear ratio steps, consumption values and emission values have been reduced even further in comparison with the automatic gearbox 09D. Once again, the eight forward gears are made possible using the tried-and-tested Lepelletier gear set concept. The automatic gearbox 0C8 can be supplied together with the start/stop system, and is also designed for the hybrid drive. All engine variants in the Touareg are available exclusively with this gearbox. The self-study programme describes the design and function of the 8-speed automatic gearbox 0C8 as it is installed in the Touareg. The function and design of those components which are required in the gearbox for the start/stop system and the hybrid drive are described.

The 8-speed automatic gearbox consists of:

- The torque converter with torque converter lock-up clutch
- The ATF pump
- The valve chest
- The planetary gearbox according to Lepelletier
- The gearbox housing
- Auxiliary hydraulic pump for gearbox oil
- ATF pre-heater

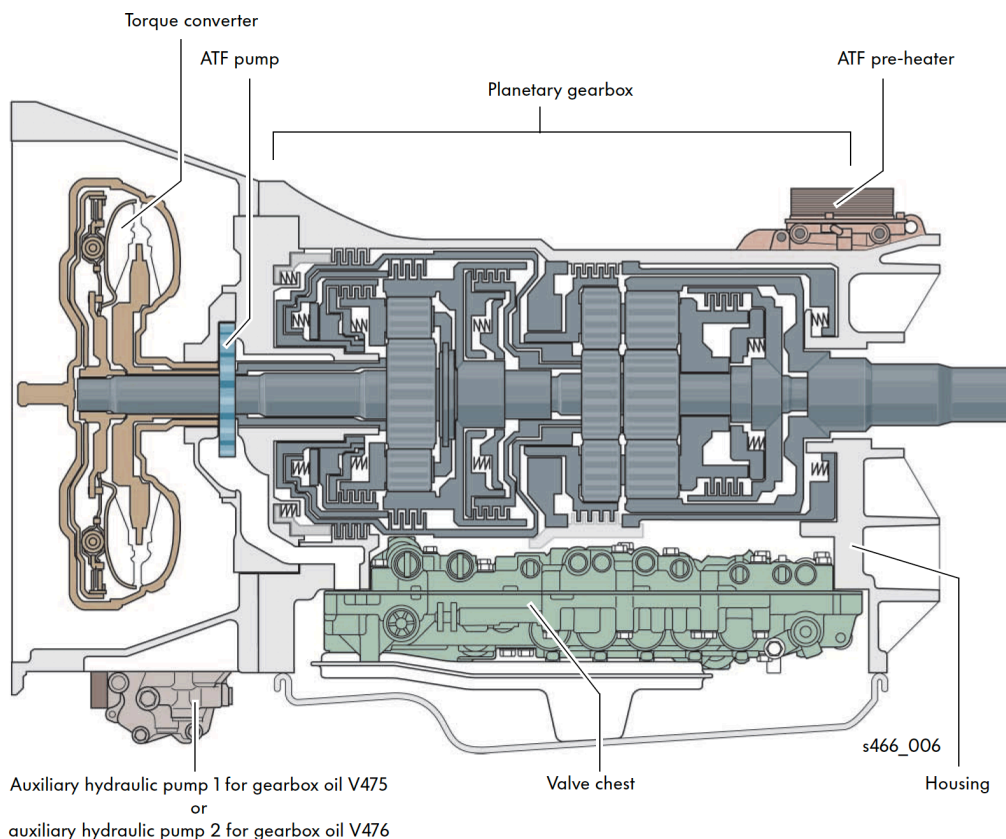

0C8 gearbox

The 0C8 automatic gearbox has an innovative thermal management system. The cooling system is only used by for other consumers once the combustion engine has reached its operating temperature. Via the CAN data bus, the gearbox control unit receives the information that the gearbox can be heated. The gearbox control unit supplies the cooling oil valve N471 with current; as a result, the pneumatic cut-off valve (rotary piston valve) is opened due to the vacuum which is released, and the warm coolant flows through the ATF pre-heater (plate heat exchanger) mounted on the gearbox.

The ATF pre-heater consists of a set of plates soldered together to form a heat exchanger through which coolant and ATF flow. In a very tight installation space, this leads to a relatively large heat transfer area, by means of which the coolant's heat is transferred to the ATF.

These gearboxes has the hill-holder function, that consists in secure the vehicle to prevent it from rolling back and enables comfortable starting off on slopes. In the Touareg 2015, the hill-holder function is undertaken by the electronic parking brake via the ABS control unit at an ATF temperature of less than approx. 10°C. At temperatures above 10°C, the function is carried out by the gearbox. If the automatic gearbox control unit J217 detects a slope based on the rolling resistance whilst simultaneously detecting a vehicle speed of "zero", it shifts to 2nd gear. Rolling back is not possible in 2nd gear, because the double planetary gear set's annulus would have to rotate backwards counter to the locking freewheel. The freewheel is only released when the starting torque is greater than the grade resistance, and the vehicle moves off comfortably.

The design and function of the gear change mechanism in the Touareg has been taken from the Audi Q7. In the Touareg, the gear change mechanism and the selector housing cannot be separated.

So in conclusion the 0C8 gearbox that mounts the Volkswagen Touareg is an evolution of the great 09D Audi Q7 gearbox.