

Advanced Concept Design

Antonio Chozas

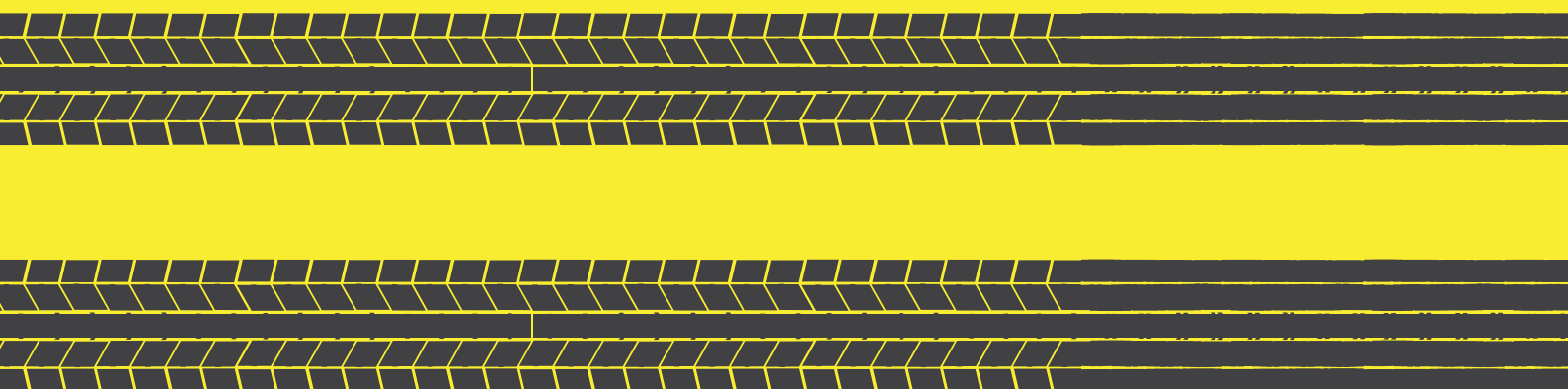

**AMIGO**

# ABSTRACT

The company Océ is planning to introduce the Artificial Intelligence technology in their printing systems, so they can increase their products efficiency and have a better portfolio to offer to their customers. This A.I. arrival will change drastically the way of working in the printing companies: operators will stop scheduling the orders by themselves, and they will just receive orders from a central system which schedules automatically, in the most efficient way. Here comes the problem assigned to us (TU Delft students) by Océ: Design ways of interaction between operators and the printer swarm, where the operators fulfill the printers needs while avoiding the mental problem of feeling like slaves of the system.

For the presented solution in this report, on one hand are studied the reasons that can lead to the mental problem, and how to solve it; and, on the other hand, it is studied how to help to reach the maximum efficiency of the whole system, which involves operators, printers and A.I.

This research gives way to the criteria with which the final solution is build: a single-seat vehicle, that will be given to each operator. Its main characteristics are:

For fighting against the mental problem:

- Enables a 2 way-communication between system and operator, giving the operators the chance of taking decisions.

- Reduces the 'master figure' (attributed to the scheduling system), being the vehicle (representing this scheduling system) used to do the tasks cooperating with the operator.

- Add fun. Makes the activity more enjoyable.

- Referring to the efficiency, the vehicle gives speed and makes easier the action of carrying loads, improving the operator's performance.

Along this report, it is shown the design process that leads to the idea to solve the raised problems, as well as the finals design that shapes this idea.

# TABLE OF CONTENTS

- 0. Abstract
- 1. Introduction
  - 1.1. Scheme
  - 1.2. Assignment
  - 1.3. Vision
  - 1.4. Approaches
- 2. amiGO
- 3. Why amiGO
  - 3.1. Communication device
  - 3.2. Cooperation + superiority feeling
  - 3.3. Attractive design
  - 3.4. More speed + ease carrying loads
- 4. How amiGO
  - 4.1. Main components and measures
  - 4.2. Manoeuvrability
  - 4.3. Loads elevator
  - 4.4. Interactive Key
- 5. Discussion
- 6. References
- 7. Appendices

# SCHEME

First of all, a summary of the design process is provided in the next page.

This scheme summarizes the design process from chapter 1 to chapter 3, and shows the logical steps that have been made to reach the final design.

Because the design process is very logical, and the steps are really important to understand the solution, this scheme it's going to be all the time next to the explanation indicating the design phase of the moment.

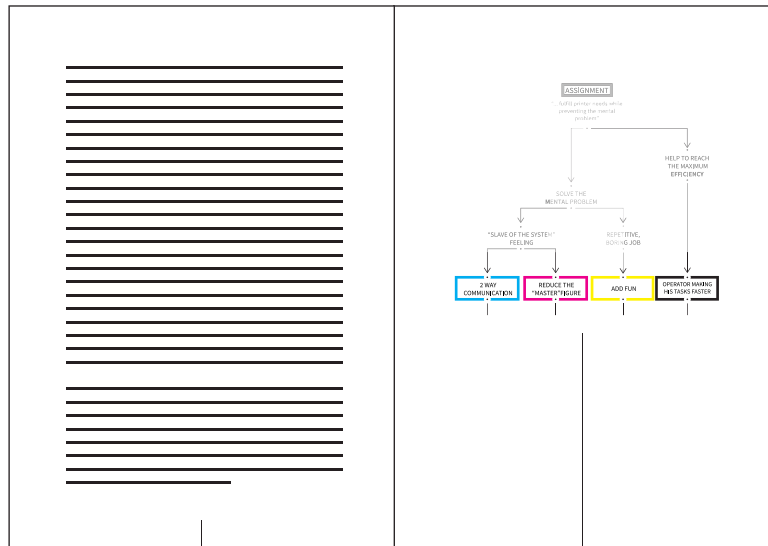

Process explanation

Current step

# ASSIGNMENT

"... fulfill printer needs  
while preventing the  
mental problem"

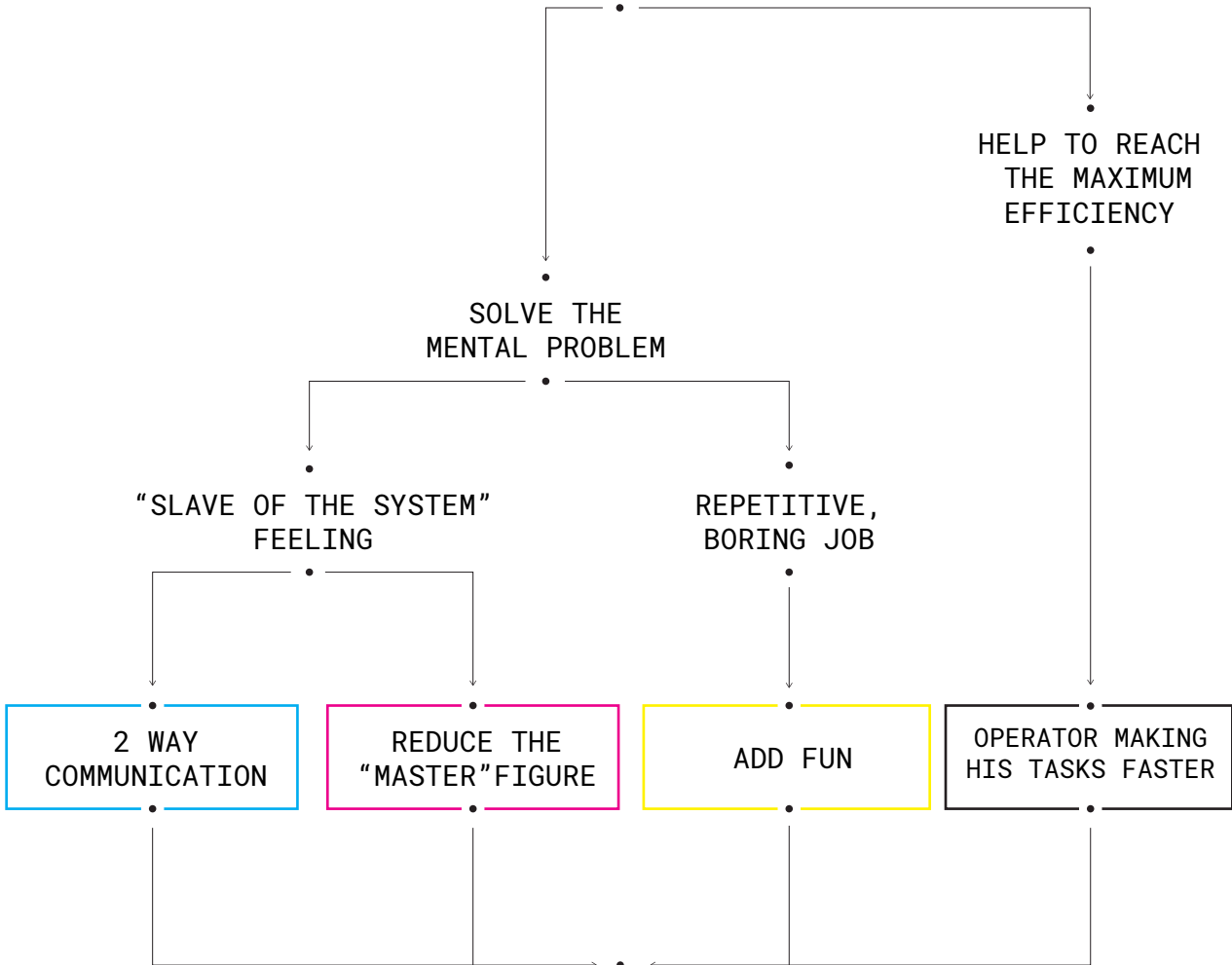

# VEHICLE

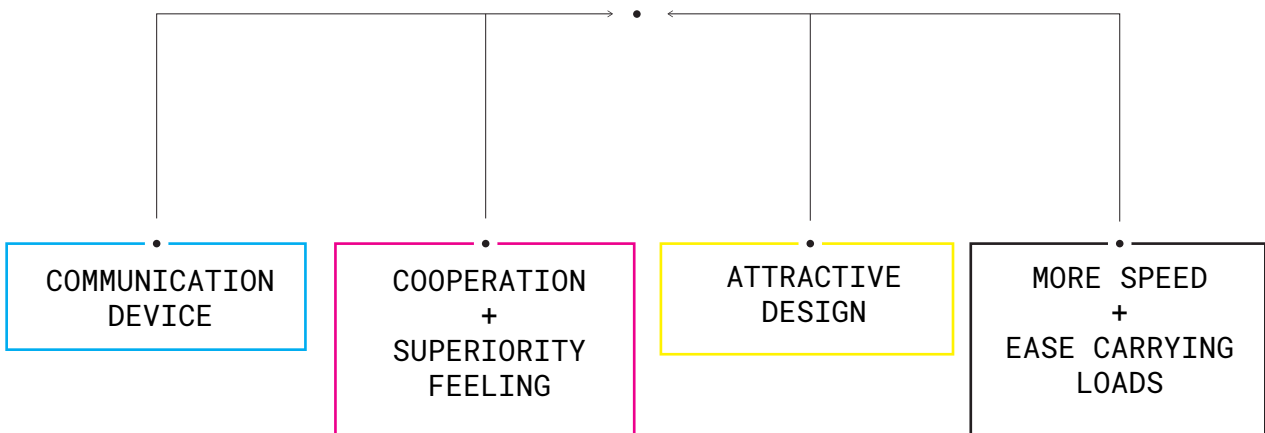

## ASSIGNMENT

During the first meeting with Océ, the company showed how they envision the future of the printing companies after the implementation of the artificial intelligence. In this vision, the artificial intelligence will schedule all the orders in the most efficient way, and operators will be told what to do. Sometimes, the system will be changing its schedule constantly, which can affect badly to the operators work. The interaction between printers and operators will not be one to one, but an operators 'team' will interact with the whole system.

After showing this future situation, an assignment was briefed, which can be summed up in two important points:

Look for ways of interaction between the 'operators team' & 'printer swarm', that helps the operators to fulfill the printer swarm's needs.

How to prevent in the operators the mental problem of 'not being in control' and 'feel like a slave of the system'



A CANON COMPANY



## ASSIGNMENT

“... fulfill printer needs  
while preventing the  
mental problem”

# VISION

In order to have a better knowledge about which solution could fit better with the company interests, a company analysis was carried out. After this analysis, I assumed that the main reason that Océ has for going into this 'adventure' is to improve their products efficiency, and thus, to have a more interesting range of products to offer to their clients. Therefore, here it is the first point of my vision: help to achieve the maximum efficiency. The organization which seems to be the most efficient is the following:

- A central system, which using A.I., is able to schedule all the incoming orders to be made in time. Once everything is scheduled, this system activates the correspondent printers and communicates individually to each operator which task he needs to do.

- Printers constantly working, which will need somebody to fill them when being empty (ink, paper, etc... ) and to fix them.

- Operators constantly doing the tasks that the central system is ordering to them: fix printer 5, fill paper of printer 12, pick up the finished books from printer 24, etc ...

With the printers and the operators working constantly, "listening' to central system orders, the maximum efficiency will be achieved.

On the other hand, the mental problem warned by Océ, is meant to happen in this 'efficient scenario':

- The operator is going to be constantly receiving orders from the system, having no chance of taking decisions.

- The relationship between operator & system is going to be based only in receiving orders.

These two factors will probably lead to the 'slave of the system feeling' invading operators mind.

In addition, with this new scenario proposed, arrives a new way of working for the operators, which seems to be way more repetitive, passive and boring.

For these reasons, the second purpose of my vision is to avoid this mental problem to happen in operators mind, designing solutions in order to fend off the 'slave of the system feeling' and adding some fun to their daily job.



## ASSIGNMENT

"... fulfill printer needs  
while preventing the  
mental problem"

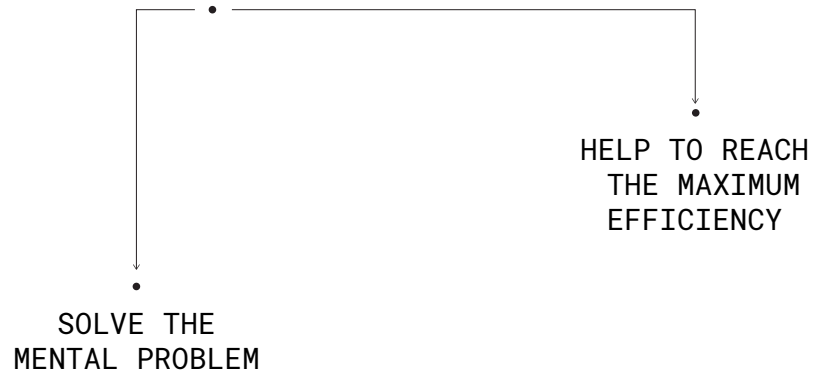

# APPROACHES

Once the problems had been stated at the vision, next step was how to approach them in order to solve them.

With this objective, was convenient to deeply analyze the 'slave of the system' concept to find what is behind of these words.

First of all, a slave exists when a master exists; and, in this case, was quite clear who was each character:

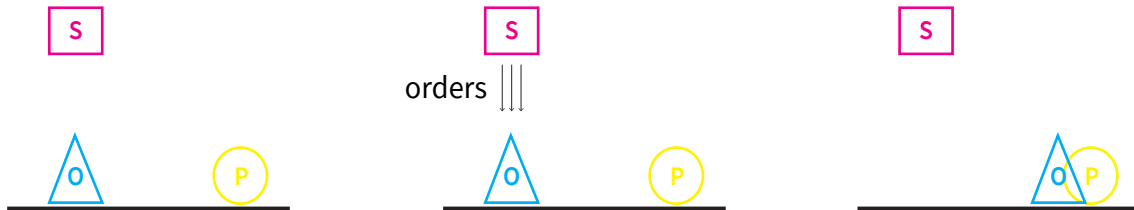

S=System = master / O=Operator = slave / P=Printer= task ordered (leyenda)

So, one way of getting rid of the 'slave' feeling could have been by removing the 'master' from the equation. However, this option was not possible, as it had been stated previously that the operators should be constantly receiving orders from the system to achieve the desired maximum efficiency. Instead of removed, the 'master' figure could be modified by lowering its 'master appearance', as it can be seen in the following example.

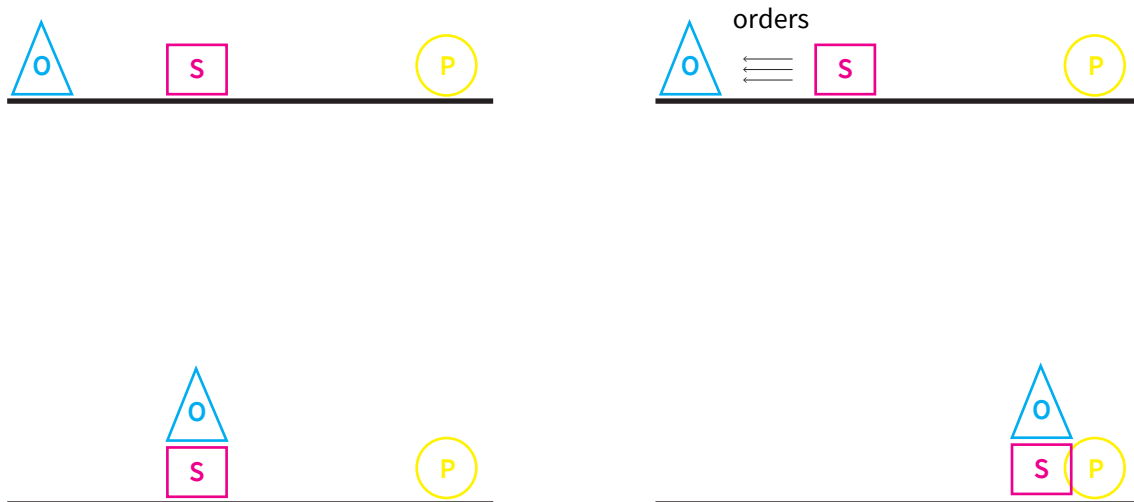

ASSIGNMENT

"... fulfill printer needs while preventing the mental problem"

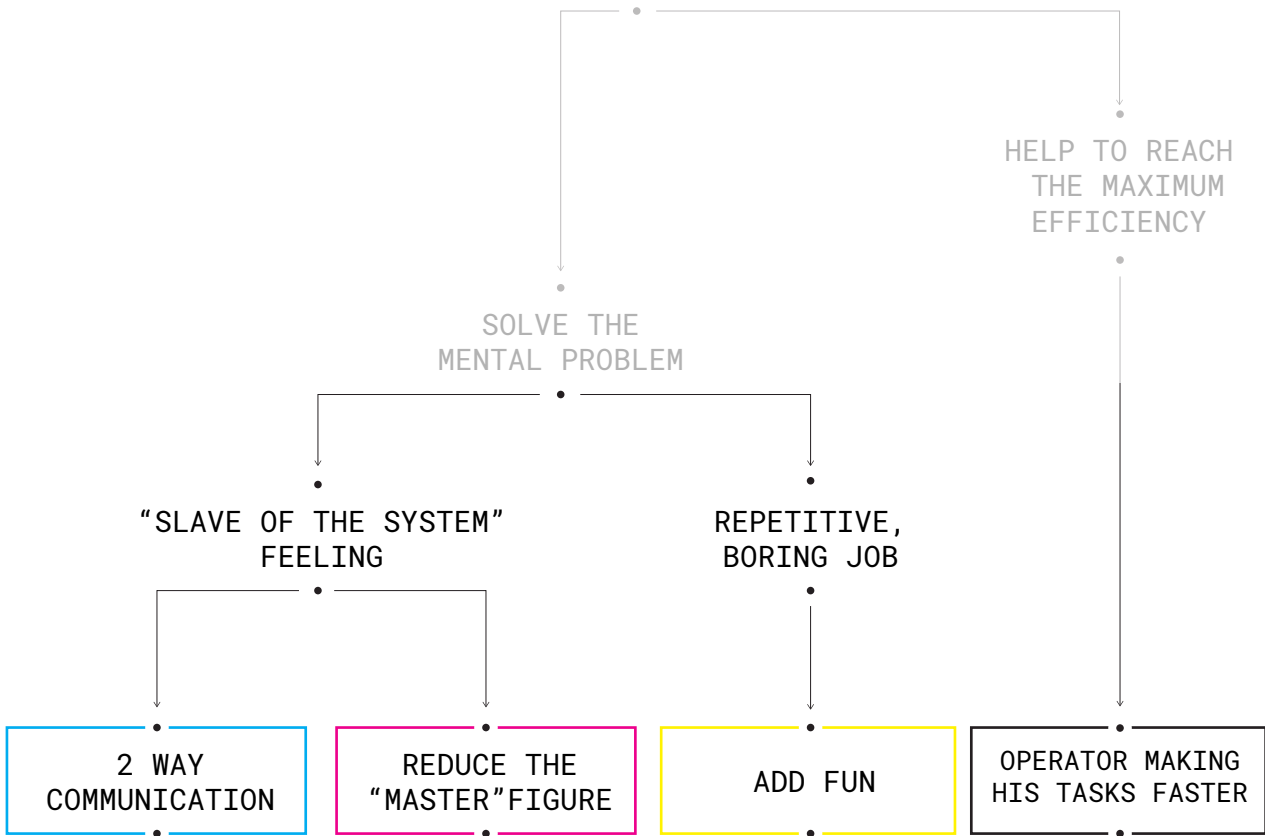

## APPROACHES

By this way, with the operator needing to use the system to do the task ordered, the 'master figure' was forced to collaborate with the operator in doing the task. Then, master figure is not so master figure, and therefore, slave figure is not so slave figure.

A metaphor which shows this concept is when a coach orders physical exercises to his team but goes with them sharing the suffering.



Real Madrid players running with their coach

Analyzing in a different way the concept 'slave of the system', it can be understood that the operator feels like a slave because he has no chance of taking decisions, and his relationship with the master is based on 1-way-communication (receiving orders).

From this analysis of the phrase 'slave of the system' came out two different approaches to low the mental problem:

- a) Enable a 2 way-communication channel where the operator has chance of taking decisions.
- b) Reduce the 'master figure'. Design a system where the operator has to use the 'master' to be able to accomplish the tasks ordered.

Apart from these two approaches, there are two others which the purpose of solving other two problems mentioned before:

- c) Add fun. To avoid the boring and repetitive daily work that is meant to happen in the 'efficient scenario'.
- d) In order to increase even more the efficiency, help the operator to make his tasks faster/easier.

ASSIGNMENT

"... fulfill printer needs while preventing the mental problem"

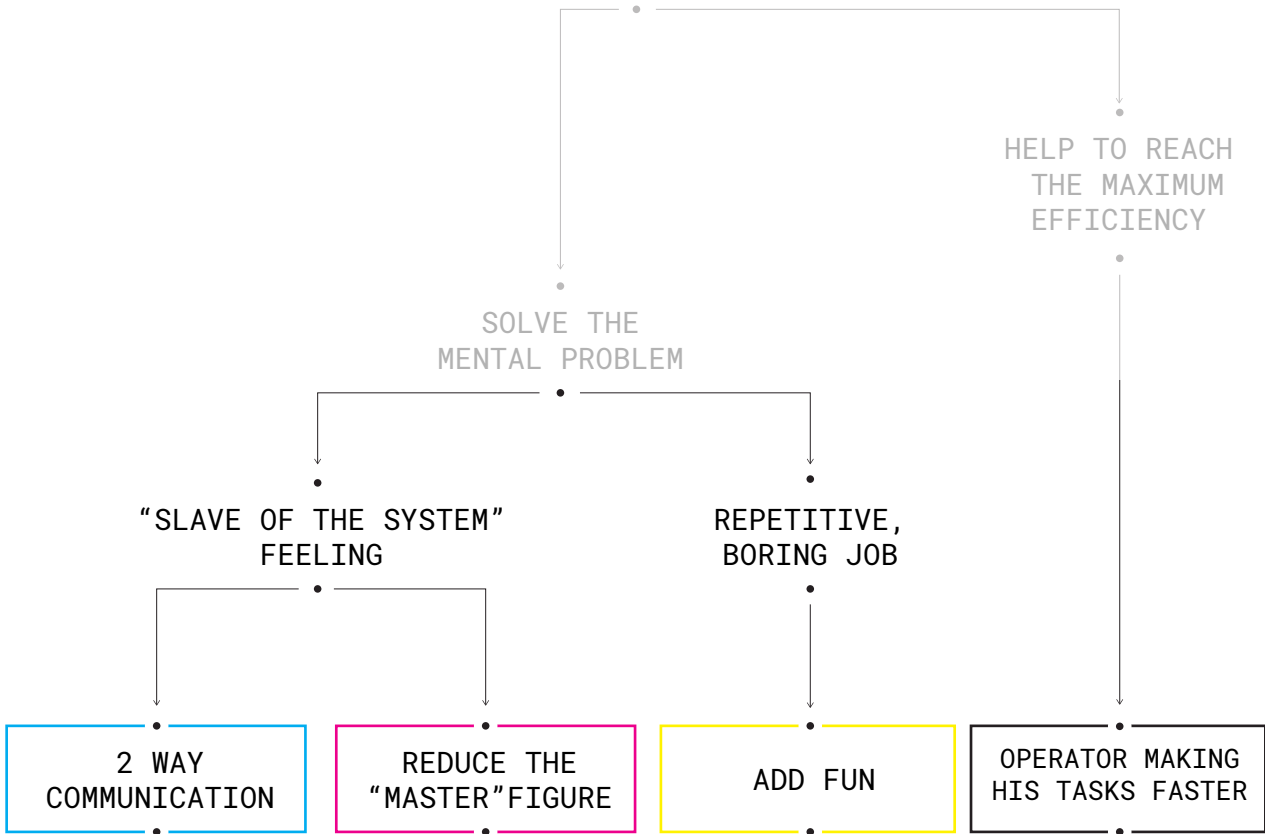

# amiGO

Using the criteria which concludes the last chapter, the final solution came out: amiGO.

AmiGO is a personal single-seat vehicle for each operator. It represents the system, showing to the operator the tasks he has to do, but also cooperating with him to carry out the tasks ordered. Therefore, amiGO enables the communication between operator & system, represent the system cooperating with the operator, improves the operators performance (more speed, easier to carry loads) and makes the activity more enjoyable and funny.

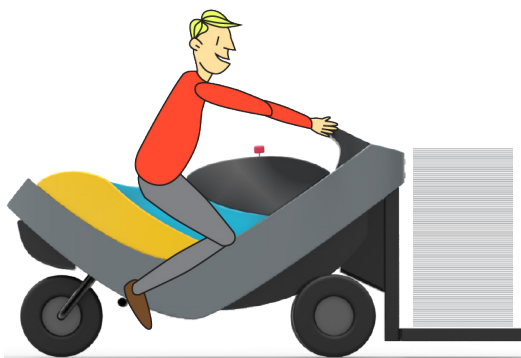
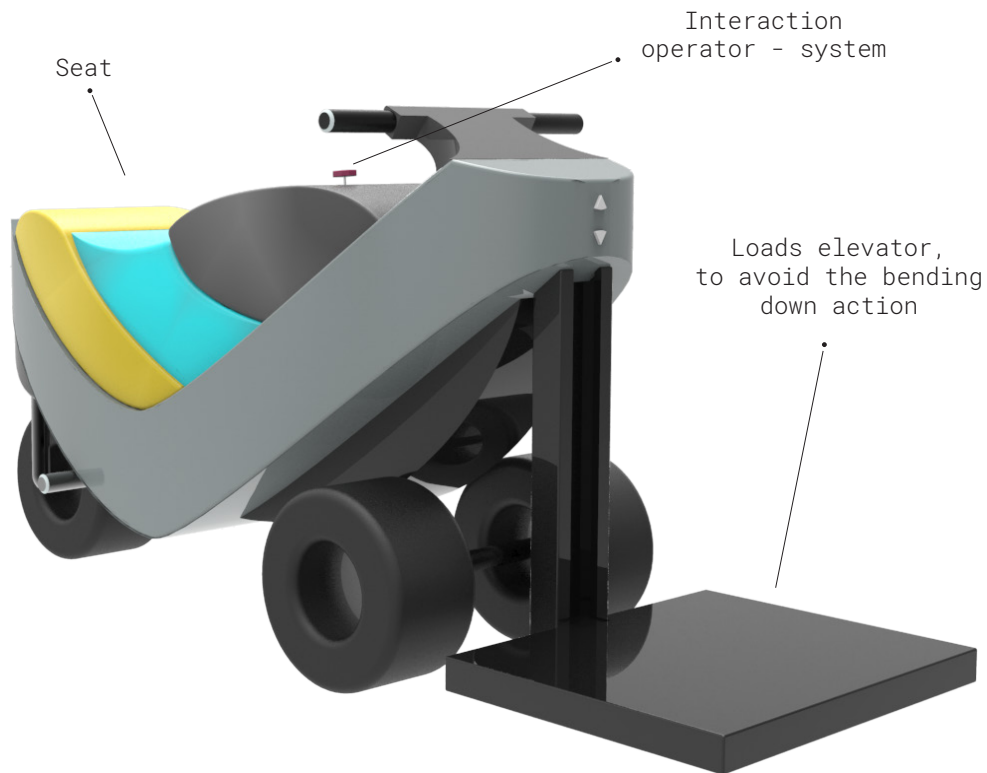

Operator driving amiGO. A paper load is being carried

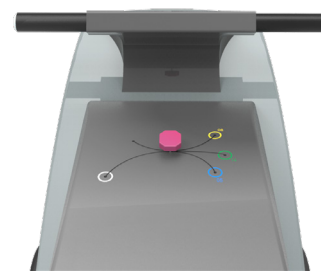

Interactive Key, used to be the communication between operator and system

ASSIGNMENT

"... fulfill printer needs while preventing the mental problem"

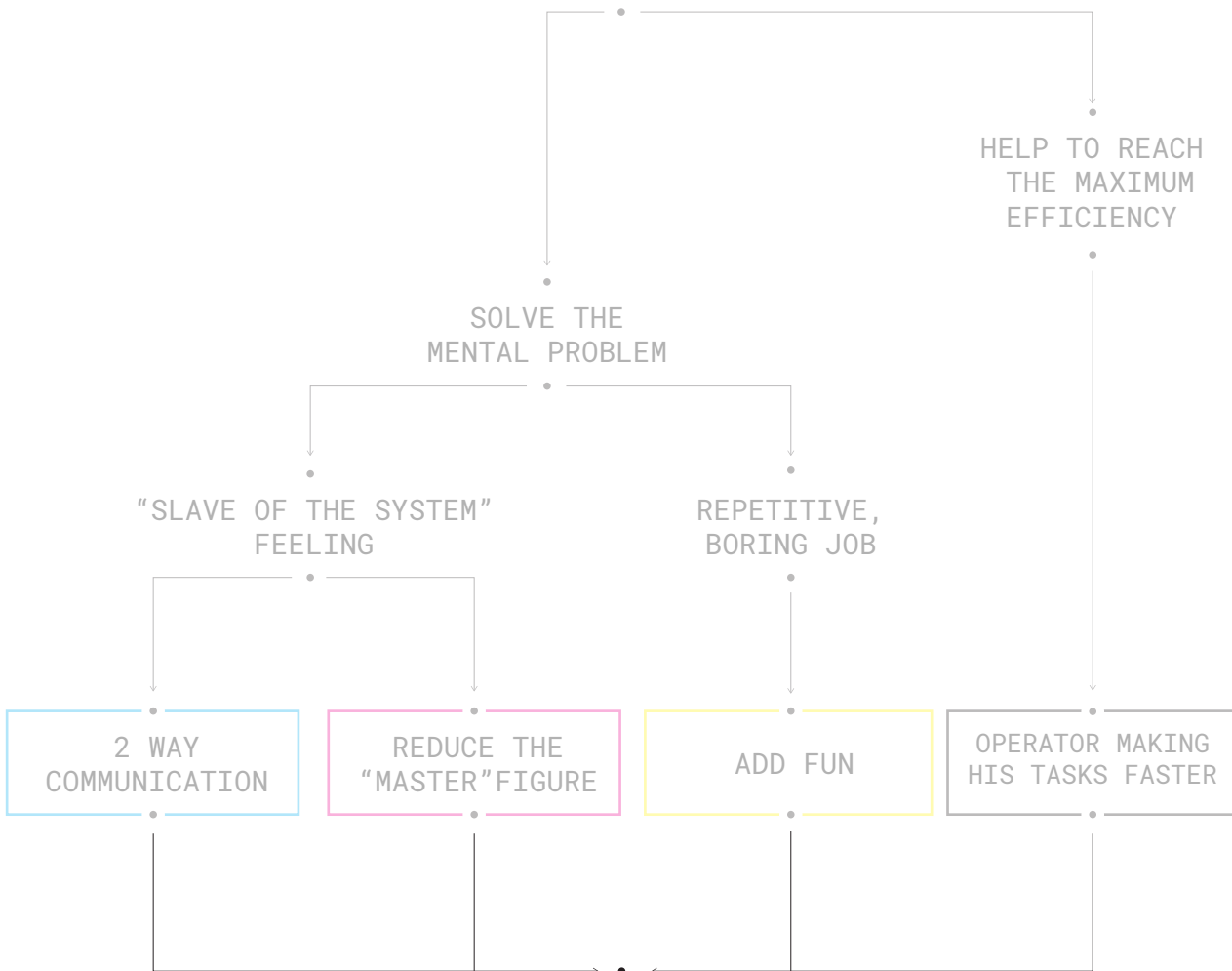

VEHICLE

## COMMUNICATION DEVICE

AmiGO brings together in itself the solutions that were looked for with the 4 approaches mentioned in chapter 1. How it is solved each problem is explained in the following points.

Enabling a 2 way-communication, where both (system and operator) can take decisions, will forge a relationship similar to the one that colleagues have, getting away from the idea of the 'slave' receiving orders.

In order of making possible this communication, first is needed to know what information needs to be exchanged.

What decisions can the operator take?

- To have a break & going to the WC. In any moment, the operator is able to decide to go to the toilette or to have a break. By this way, the operator has the control of the moments where he wants to rest. How would the system cope with this situation? The system will know the number of workers that are having a break and how much time are they going to be without working. With this information, the orders can be rescheduled in a way that the operators who are still working can manage the situation.

- Select the task he wants to do (within the 3 most urgent tasks). By this way, operators gain some freedom in choosing which task to do.

What information about the operator does the system need?

- Accepted task & finished task. By this way, the system will remove the accepted task from the others vehicles. Also, once it is known when the operator started the task, the time that he is going to spend in doing the task can be estimated. (Necessary information for the scheduling).

- When an operator is doing a break, and how long is going to take that break. (Also necessary for the scheduling).

In consequence, the enabled communication must have:

Output:

- 3 most urgent tasks
- Specification about which task it is and where it is.

Input:

- Accepted task
- Finished task
- WC break (10 minutes)
- Long break, specifying the number of minutes.



ASSIGNMENT

"... fulfill printer needs while preventing the mental problem"

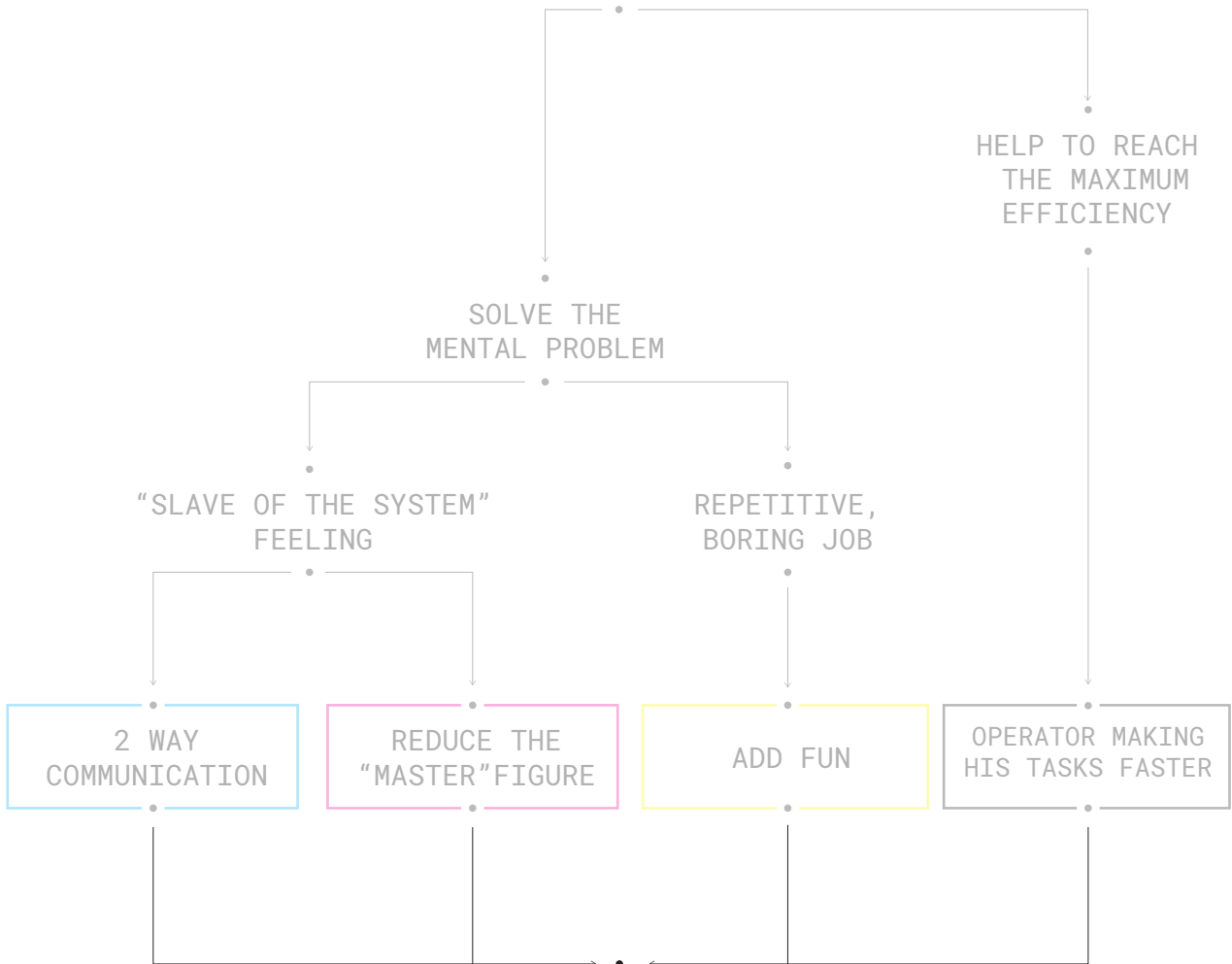

VEHICLE

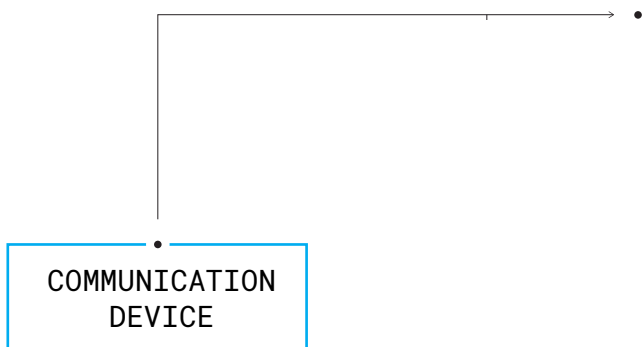

## COMMUNICATION DEVICE

How is the interaction going to be?

In order to avoid the feeling of communicating with an external body (a computer controlling everything), conventional methods such as screens are eluded. On the contrary, the objective of the interaction is that the operator feels like he is interacting with a physical entity.

As inspiration about how to reach this physical interaction, a research about the concepts "Rich interaction" and "Tangible interaction" was carried out (some examples of these interactions are shown in the appendix).

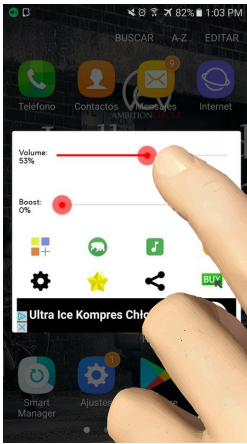

Modifying the volume in a touch screen



Modifying the volume in an analog device

In the first picture it's shown the kind of interaction to be avoided. In the second one, it is shown an example of which interaction it is looked for.

Once it is known WHAT needs to be in the communication, and WHICH KIND of interaction should it be, here is the result.

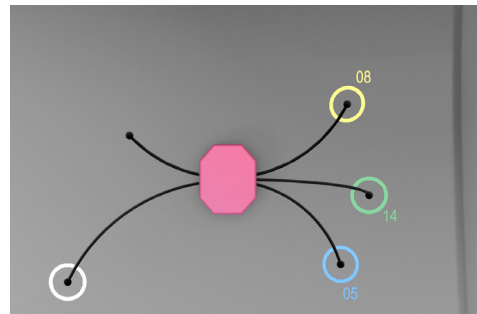
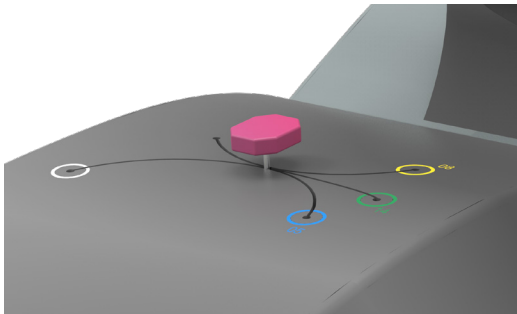

ASSIGNMENT

"... fulfill printer needs while preventing the mental problem"

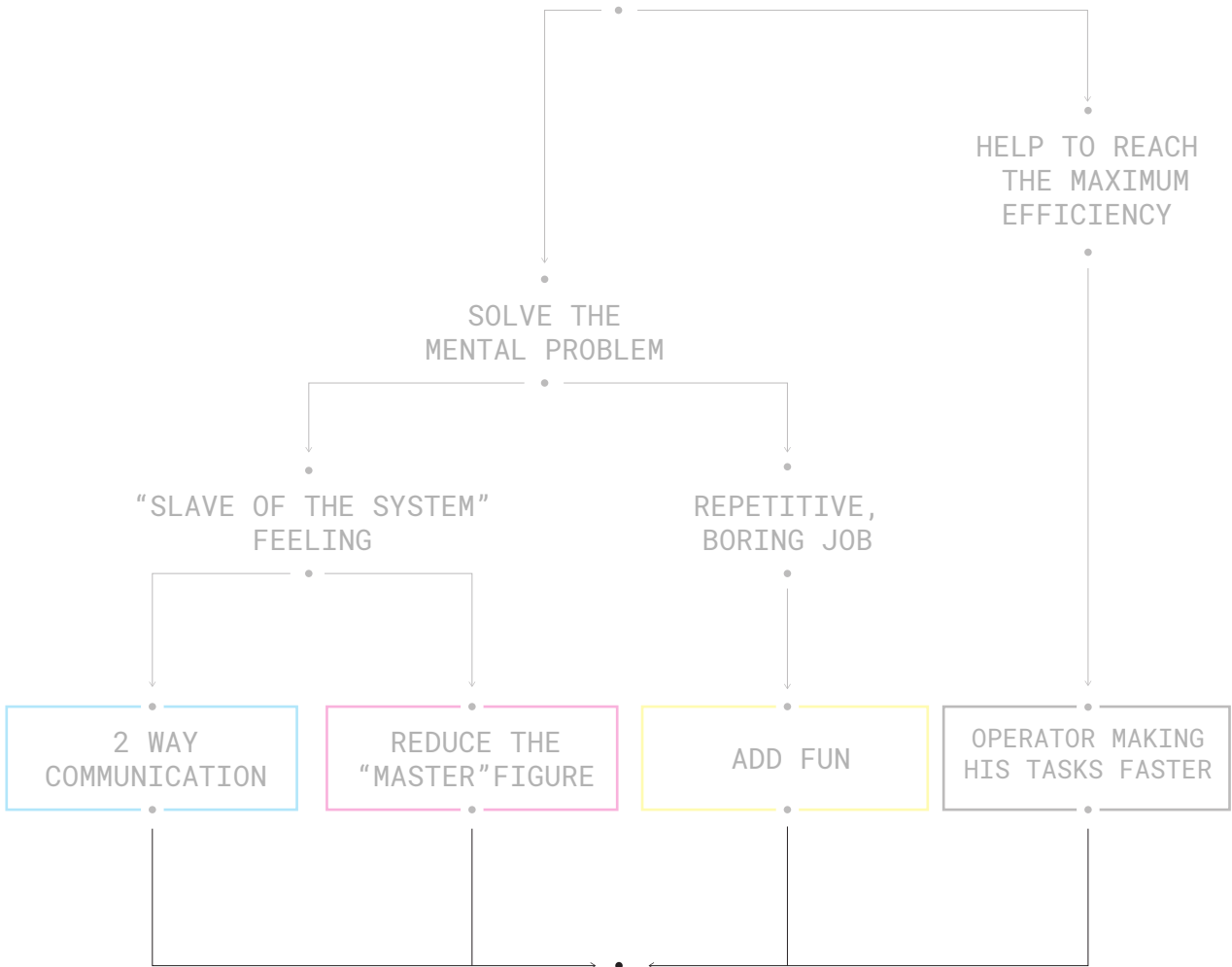

VEHICLE

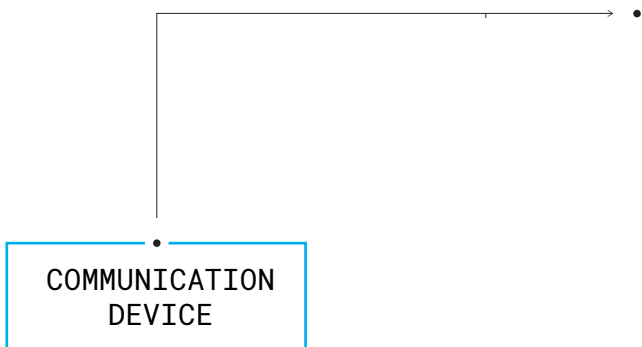

# COMMUNICATION DEVICE

The concept is that the 'block' can be moved to the different positions, representing what action is being done by the operator in each moment. There are 6 possible positions:

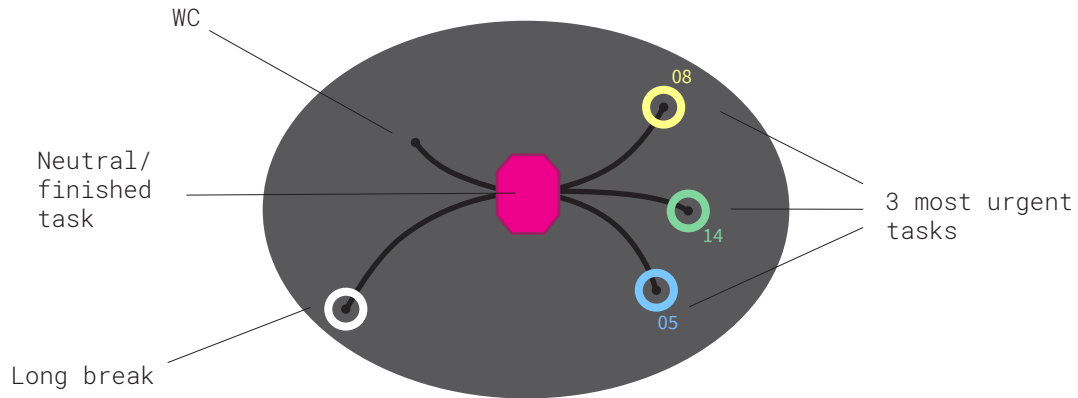

Then, here is shown how the input and output actions are carried out.

**Output:**

-3 most urgent tasks + which task & where

Colour indicates the kind of task.  
e.g. filling paper



Number indicates which printer needs the task

**Input:**

- Accepted task
- Finished task
- WC break (10 minutes)
- Long break + number of minutes.

- Moving the block there*
- Moving the block to neutral*
- Moving the block to WC*
- Moving the block to*

*long break + turning the block the quantity of minutes required*

Before turning,  
0 minutes

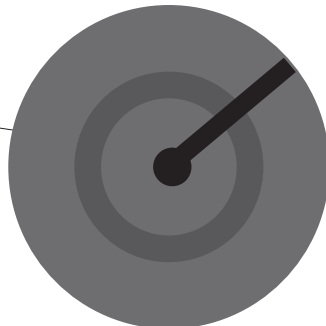

Turning the  
block 270°,  
45 minutes

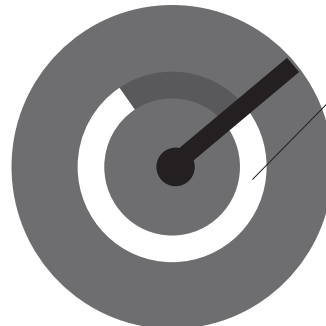

ASSIGNMENT

"... fulfill printer needs while preventing the mental problem"

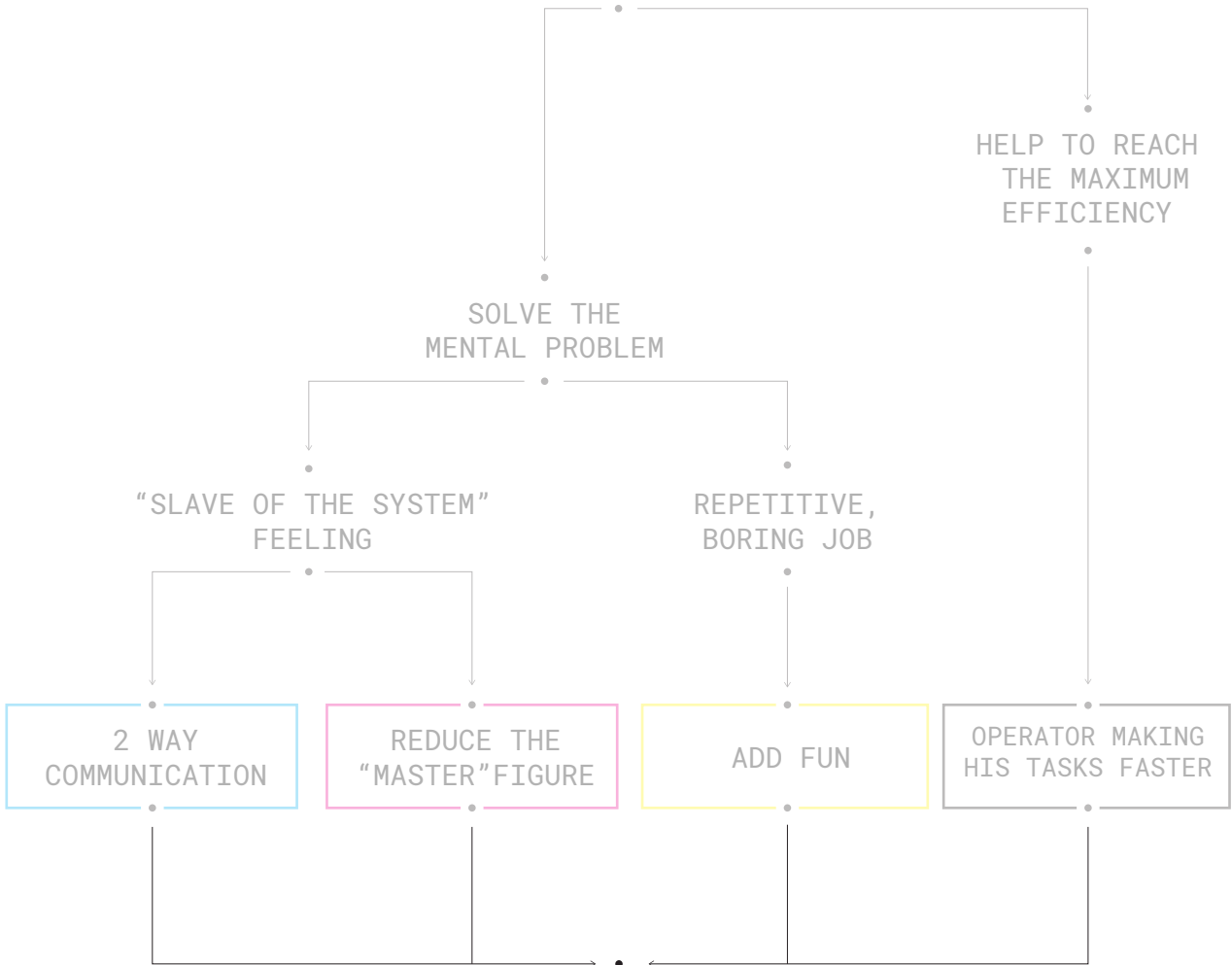

VEHICLE

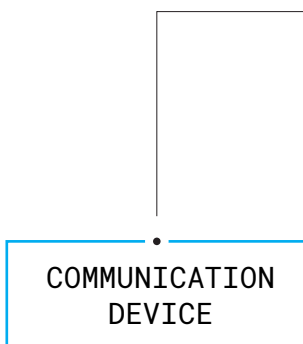

## COOPERATION + SUPERIORITY FEELING

In the eyes of the operator, the system (what schedules and gives orders) is the vehicle itself. So, if after communicating the task to the operator, the operator uses (driving the vehicle) the system to carry out the ordered task, will mean that both are collaborating to accomplish the task.

What were supposed to be slave and master are now working together. This fact dilutes the 'master figure', opening the way to a colleagues-relationship.

|   |  |
|---|--|
| -Complete paper.                            | <i>Transport</i>                           |
| -Bring paper from warehouse.                | <i>Transport + carrying loads</i>          |
| -Refill ink an other liquids.               | <i>Transport + carrying liquids</i>        |
| -Replace ink containers.                    | <i>Transport + carrying ink containers</i> |
| -Remove waste paper from error deposition.  | <i>Transport</i>                           |
| -Remove printed piles.                      | <i>Transport</i>                           |
| -Move printed piles to finished department. | <i>Transport + carrying piles</i>          |
| -Rectify papers faults.                     | <i>Transport</i>                           |

List of the possible operator's tasks, and how amiGO will collaborate.

In addition, the relative positions of both subjects -operator and system- lightly increases the superiority feeling of the operator against the system.

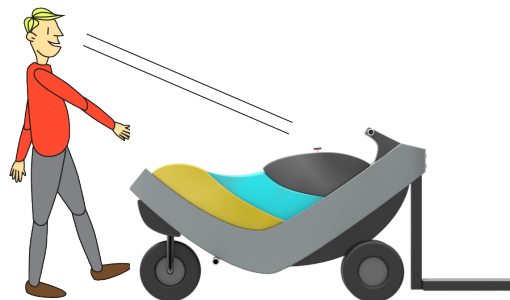

The operator needs to look down to communicate with the system, and, going further, he is the owner of the vehicle destination while he is driving it (he is controlling it). These two facts lower even more the identification of the vehicle as operators master.

# ASSIGNMENT

"... fulfill printer needs while preventing the mental problem"

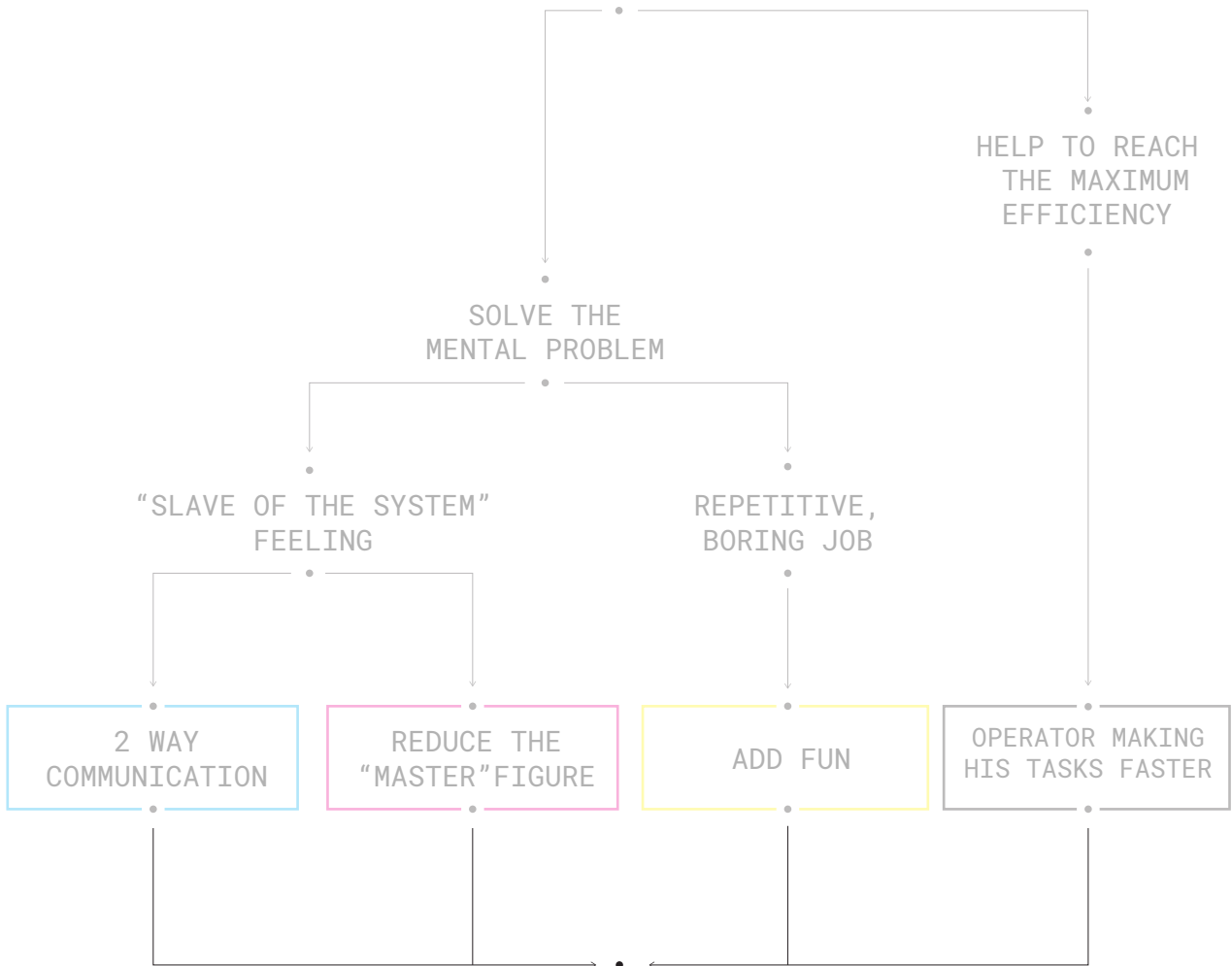

# VEHICLE

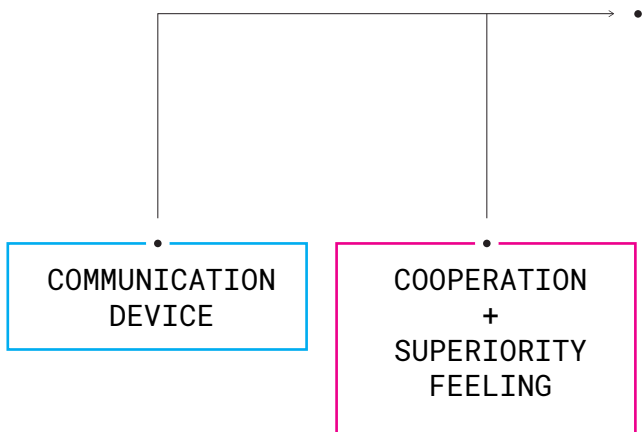

## ATTRACTIVE DESIGN

The daily work that comes with the new situation in the printer companies, appears to be tough (going from here to there, carrying loads, etc...), repetitive, and, definitely, boring. For this reason, is of crucial importance the added value that amiGO provides. Apart from avoiding the operator's physical toll (operator can use the vehicle instead of making physical efforts), amiGO turns the tasks into enjoyable activities. Driving is a funny and enjoyable activity to most people. Thus, amiGO can be seen as a sort of toy, creating fun while been driven. Also, its aesthetics try to stimulate this feature: without neglecting the professionalism, it has a slight touch of toy or racing car.

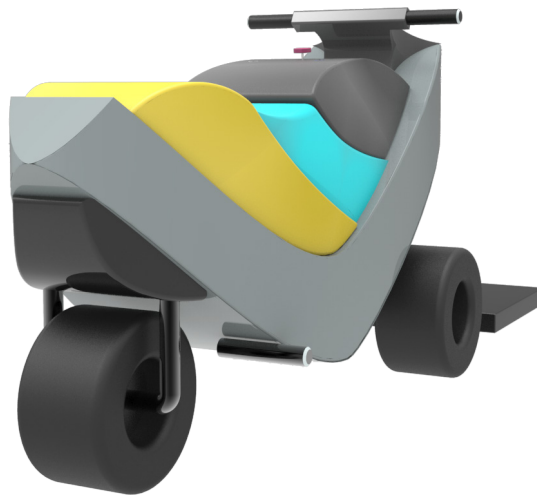

© 2015 Breda



# ASSIGNMENT

"... fulfill printer needs while preventing the mental problem"

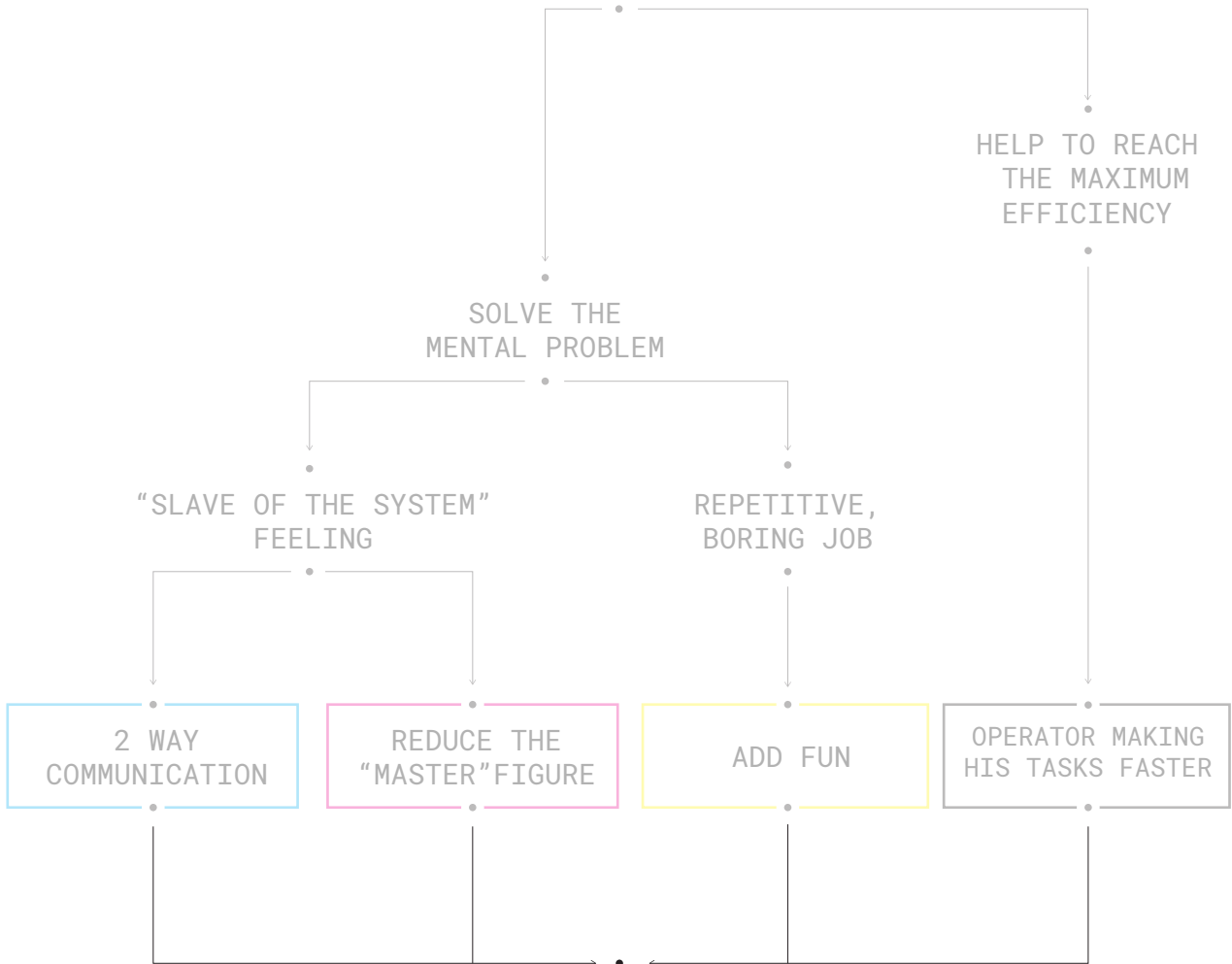

# VEHICLE

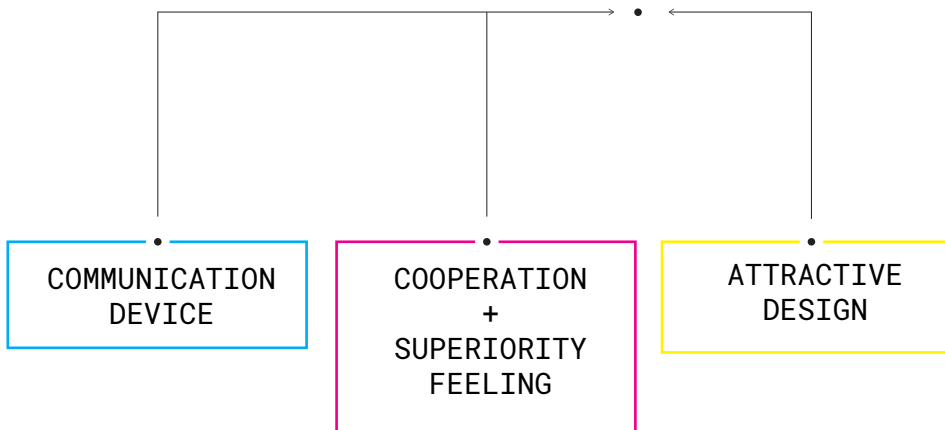

## MORE SPEED + EASE CARRYING LOADS

Increasing even more the whole system's efficiency, amiGO makes possible to operators to finish their tasks in less time.

On the one hand, gives more speed to operators, allowing them to move around the company faster than walking.

On the other hand, it helps the operators to carry loads such as papers, finished jobs or ink containers. Also, the platform where these objects are carried, is equipped with a motor that allows the elevation of the loads. Due to this mechanism, it is avoided the bending down action.

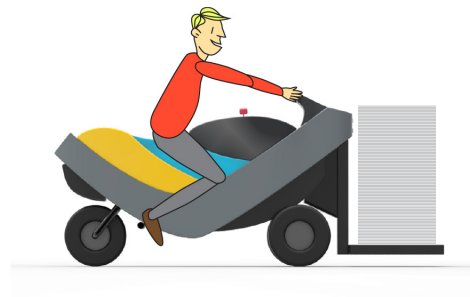

# ASSIGNMENT

"... fulfill printer needs while preventing the mental problem"

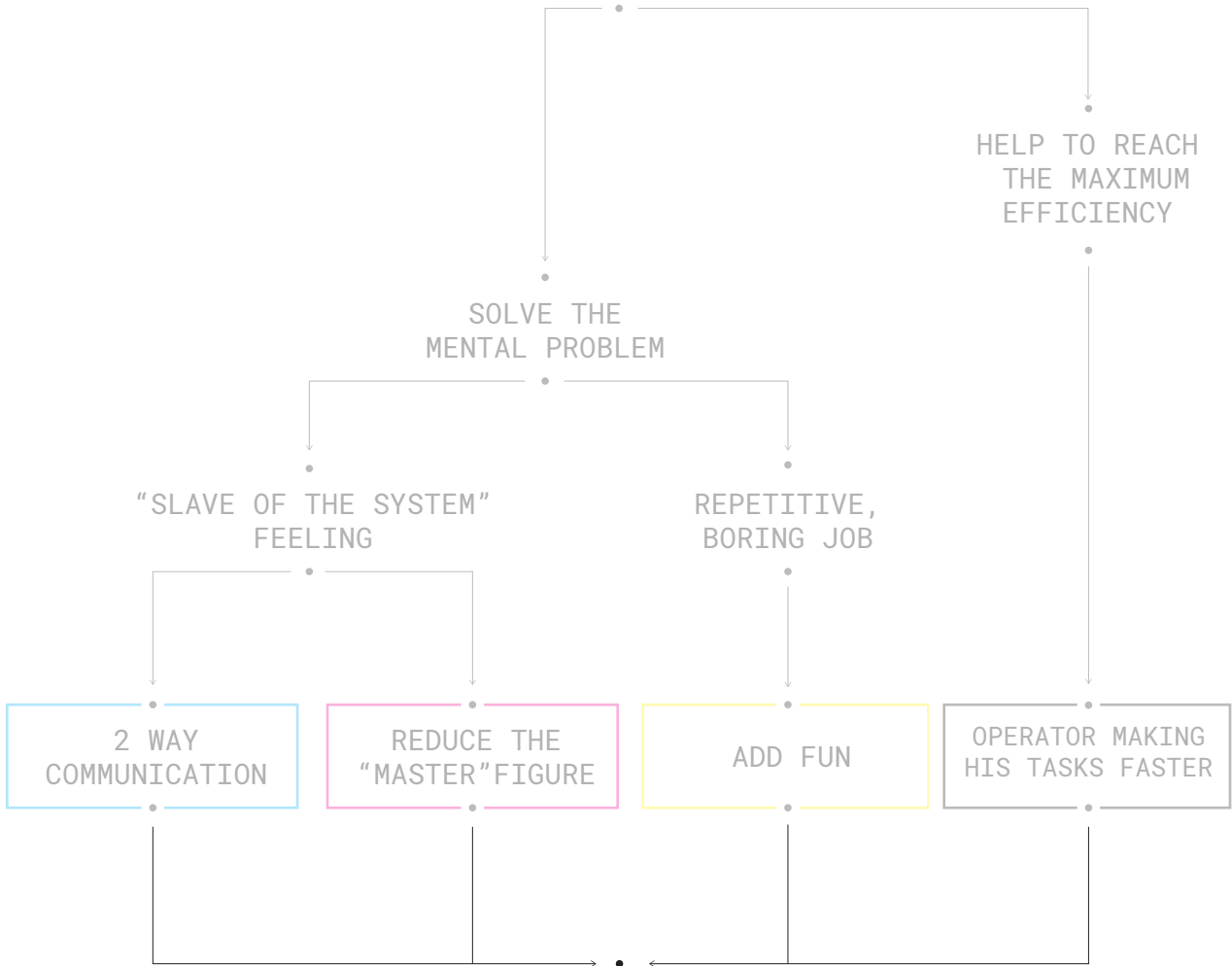

# VEHICLE

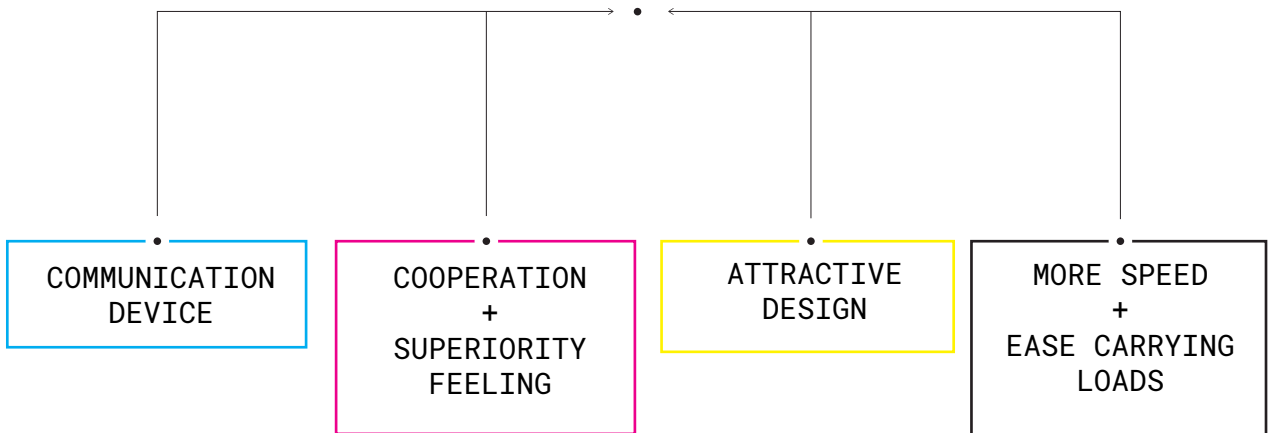

# HOW amiGO

In this chapter, are specified the amiGO's exact measures, its main components and the technical details of its more important mechanisms.

## MAIN COMPONENTS AND MEASURES

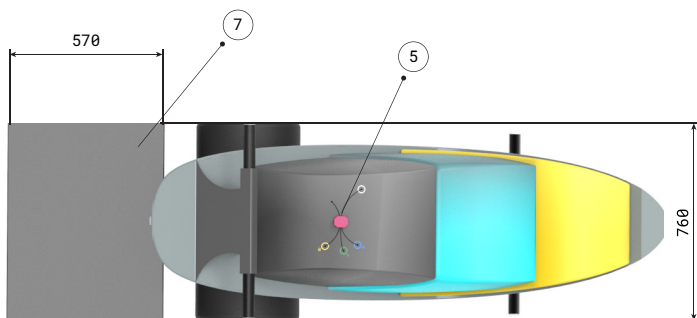
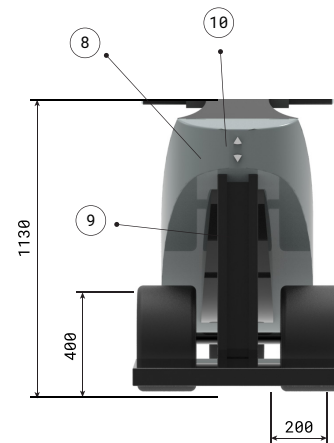
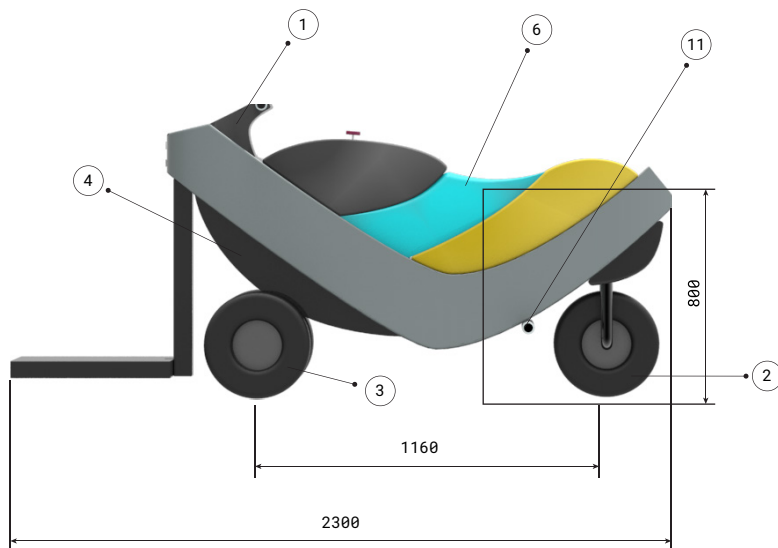

(mm)

- ① Steering wheel
- ② Rear wheel
- ③ Front wheels
- ④ Motor
- ⑤ Interactive key
- ⑥ Seat
- ⑦ Elevating platform
- ⑧ Elevating motor
- ⑨ Vertical guide
- ⑩ Up/Down buttons
- ⑪ Footrest

# MANOEUVRABILITY

Manoeuvrability happens to be a very important feature of vehicles that are supposed to work inside factories, given the constant necessity of making sharp turns along narrow corridors.



Example of printing company with its narrow corridors. (Bridge Publications)

The main problem for these vehicles is to be able to turn around in narrow spaces. Therefore, the objective is to achieve the lower turning radius possible.

After analysing other vehicles that have to solve the same problem, the most used solution and the one which fits better to amiGO, is to have a rear drive wheel motor, being the wheel able to turn in a range of 180 degrees.



Example of a rear drive wheel motor, with the rear wheel totally turned. (Heli)

# MANOEUVRABILITY

By this way, the vehicle rotates over itself, being the distance between front wheels and rear wheel the same as the turning radius. It is better explained in these following images.

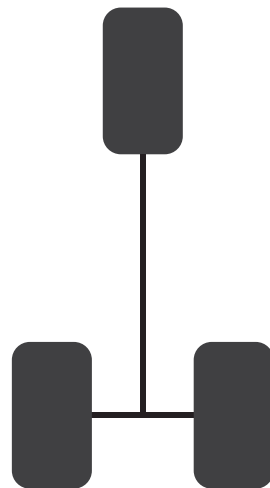
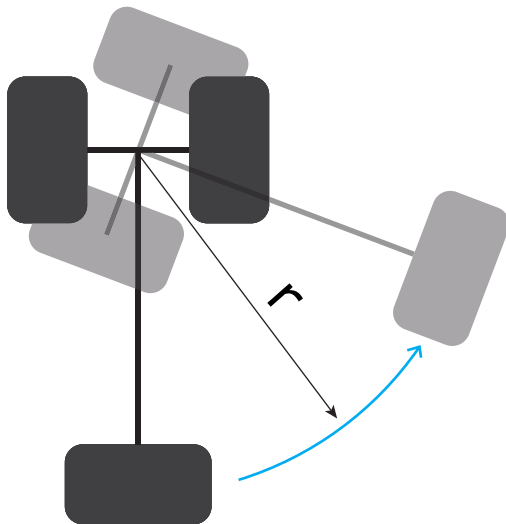
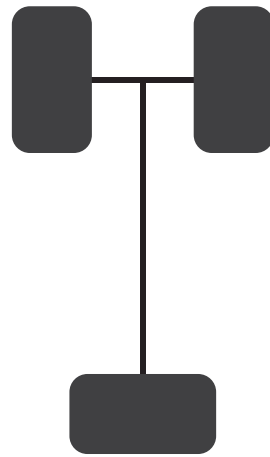
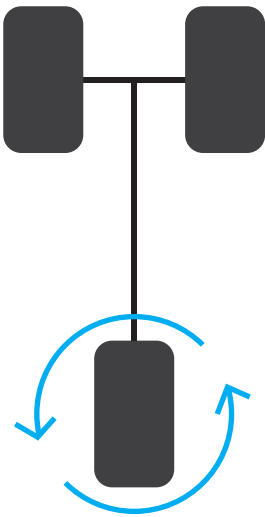

## LOADS ELEVATOR

Another important amiGO's feature is elevating the loads that have been carried. Once the operator arrives to the destination, he can elevate the loads before having to manipulate them (to fill the paper of a printer, for example), avoiding the bending down action.



Operator suffering pain in his back, because the action of lifting boxes

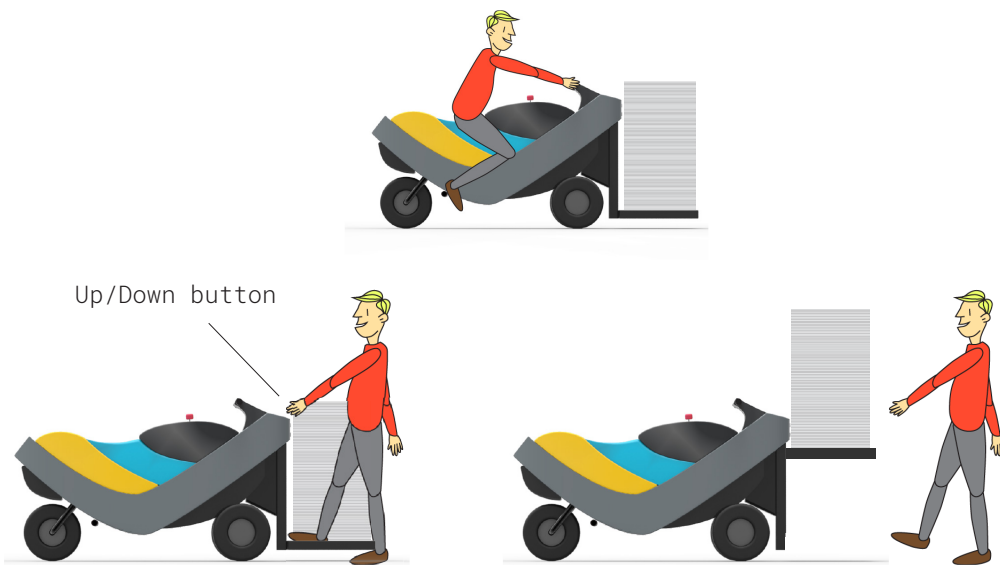

AmiGO's solution to the bending down problem

# LOADS ELEVATOR

How does the mechanism work?

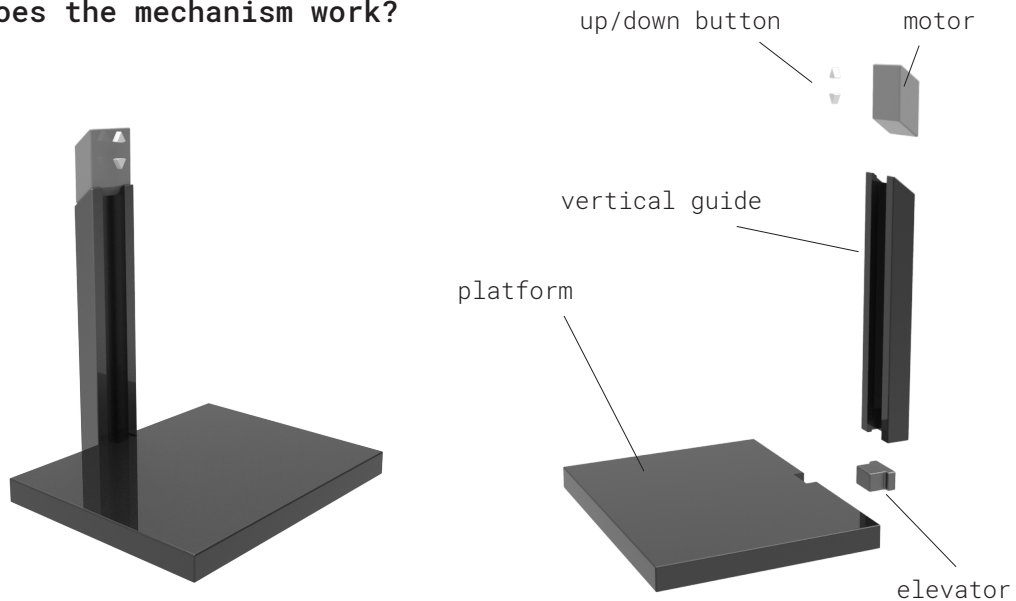

Pressing the up/down button, the motor generates movement for the elevator, which goes up or down through the vertical guide. Hereby, the platform moves the holded load.

Given that the loads will not exceed weights of 100 Kg, there is no need of a very powerful motor (like the one that the fork-lifts have). Therefore, a similar motor to the one that adjustable tables use (they are prepared to lift 250 Kg), is enough for the loads elevator.



Bekant table (Ikea)



Table's motor



# INTERACTIVE KEY

First of all, in order to know which is the better shape for the interactive key, a user test is conducted. In this user test, 4 different shapes are used.

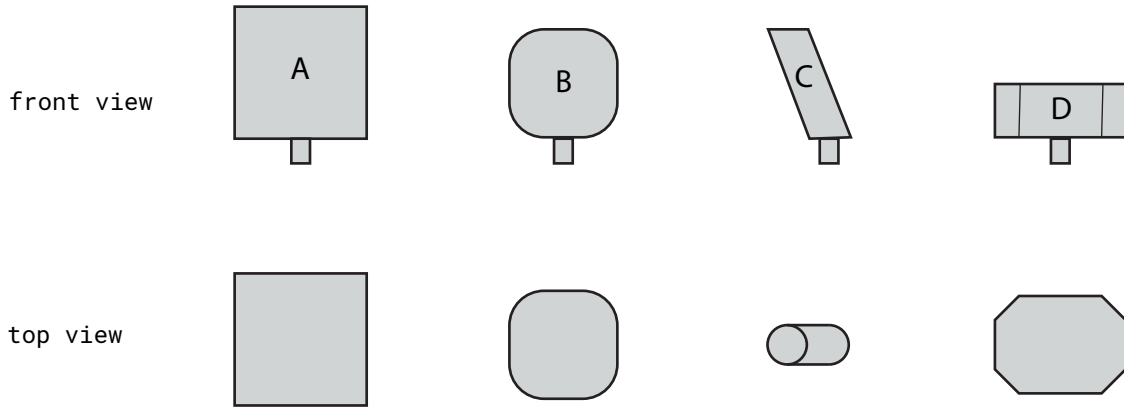

## Shape intentions:

A: This shape tries to transmit to the user the feeling of moving something big, like a stone block. The intention is to "give strength" to the decisions taken.

B: This shape looks for the most natural hand position (shown in the first picture), and, thus, its intention is to be comfortable for the user.

C: This shape looks also for the comfortability. It forces the user to a determined hand position (showed in the second image)

D: This shape has the same intention as C, but forcing the user to a different hand position (third image)



## INTERACTIVE KEY

A prototype was created using, on one hand, a metallic white-board (to attract the magnet) with cardboard guides showing the paths and different positions.

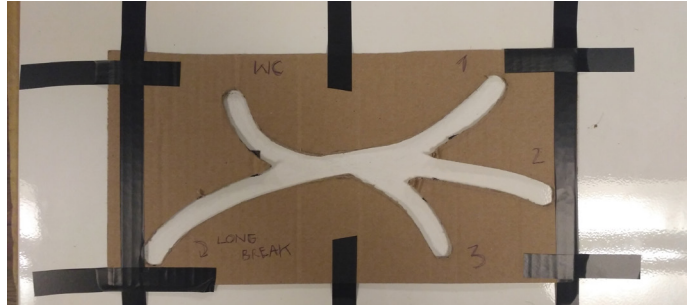



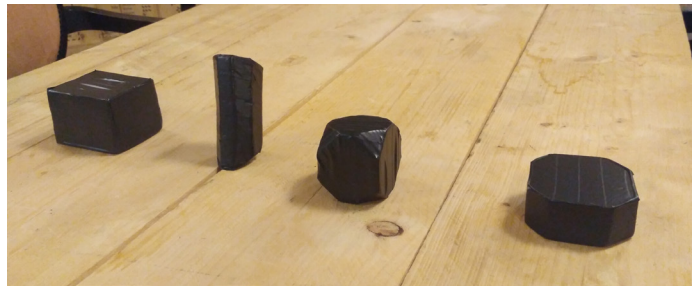

And on the other hand, 4 shapes were created with foam, all of them with a magnet at the end to allow the attraction to the metallic surface.

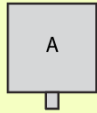

The test consists in simulate all the possible actions with the four different shapes. After this simulation, some questions were answered by the users.

Describe each experience with one word. If it wasn't relevant say nothing

|   |   |   |   |
|---|---|---|---|
|  |  |  |  |
| Which one has been more comfortable?  |   |   |   |
| A   | B   | C   | D   |
| Which one has been more enjoyable?  |   |   |   |
| A   | B   | C   | D   |
| If you had to work with it all the days, which one would you prefer to use?         |   |   |   |
| A   | B   | C   | D   |

# INTERACTIVE KEY

The form intention is:

To know which is the favourite shape to be used daily at the work. The shape with more votes is the selected shape.

Which is the relationship between the favourite shape with the most comfortable and with the most enjoyable one. Thus, the user priority (enjoyable action / comfortable action) will be clear.

The form (tested with 10 users) results are the following:

- With a percentage of 70 % of the votes, the most favourite shape is the shape D.
- In the majority of the cases, the favourite shape coincided with the perceived as most comfortable, and being different from the most enjoyable. Therefore, the user prefers a comfortable shape rather than an enjoyable one.

How does the mechanism work?

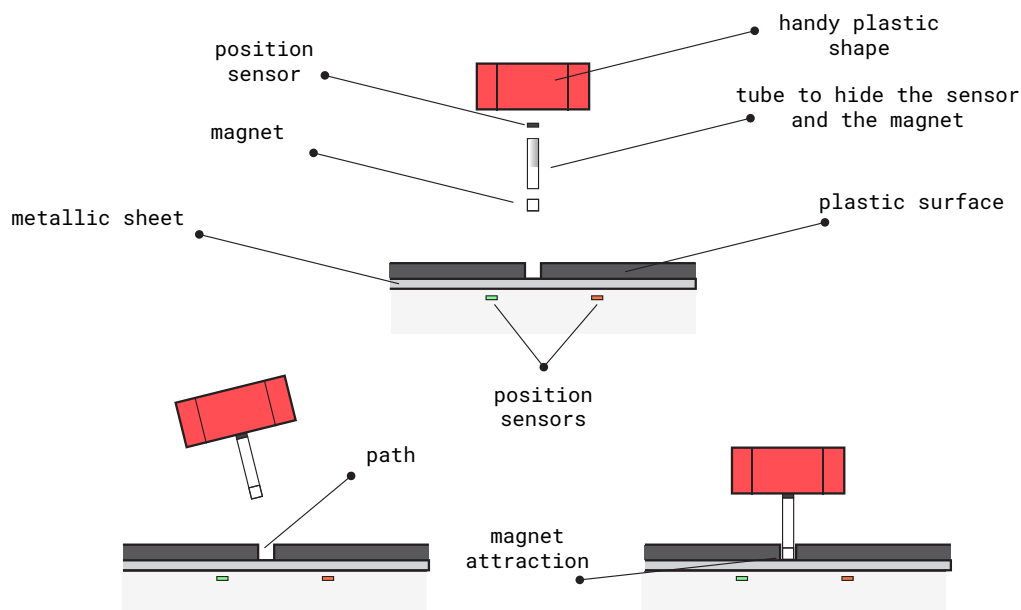

Regarding to the mechanism, the key is dragged along the paths, being the magnet attracted by the metallic material of the paths. Hereby, the key maintains itself in its position, but at the same time, it's easy to drag it to a different location. Relating to the information that needs to be transmitted (location of the key, in which position it is), the position sensors let the system know where the key is positioned at all times.

## DISCUSSION

It must be emphasized that the most of decisions taken during this design process have not been backed up by statistics, data or experts opinion. Therefore, different points could be discussed:

Referring to the first design phase (the concept behind the physical vehicle), is full of logical assumptions that are based in my own perception (issues about the master and the slave). This assumptions should be studied deeper, in order to find some statistic data to back them up.

Regarding to the technical details, I don't have the knowledge (and also did not have the time to acquire it) required to determine questions such as "which is the suitable driving system", "which are the exact pieces that the vehicle is going to need" or "how to make it efficient". Lot of more research should be done referring to this issues, if possible by experts in the field. The solutions to these questions that can be found in amiGO, are just result of an exploration about how are these problems solved in other similar products. Therefore, they are not validated, and they can only serve as the basis for future investigations.

Finally, the user test, carried out to know which was the suitable shape for the key, should be repeated with a bigger range of shapes and with more users tested. Nevertheless, the user test done can be used as well as basis for future investigations.

## REFERENCES

### Images references:

Logo Océ. Wikipedia

[https://upload.wikimedia.org/wikipedia/commons/thumb/6/6a/0c%C3%A9\\_Logo.svg/1200px-0c%C3%A9\\_Logo.svg.png](https://upload.wikimedia.org/wikipedia/commons/thumb/6/6a/0c%C3%A9_Logo.svg/1200px-0c%C3%A9_Logo.svg.png)

Logo TU Delft. TU Delft

[https://d1rkab7tlqy5f1.cloudfront.net/Websections/TU%20Delft%20Huisstijl/TU\\_Delft\\_logo\\_RGB.png](https://d1rkab7tlqy5f1.cloudfront.net/Websections/TU%20Delft%20Huisstijl/TU_Delft_logo_RGB.png)

Real Madrid training (2017). Mundo deportivo.

[http://www.mundodeportivo.com/r/GOD0/MD/p4/Futbol/Imagenes/2017/07/16/Recortada/20170716-636358377080656481\\_20170716213724-k00C-U4241758192581zE-980x554@MundoDeportivo-Web.jpg](http://www.mundodeportivo.com/r/GOD0/MD/p4/Futbol/Imagenes/2017/07/16/Recortada/20170716-636358377080656481_20170716213724-k00C-U4241758192581zE-980x554@MundoDeportivo-Web.jpg)

Screen volume. (2017). Para los curiosos.

[https://static.paraloscurosos.com/img/articles/18124/800x-800/59b7cdd3e7d13\\_screenshot\\_20170912-130310.jpg](https://static.paraloscurosos.com/img/articles/18124/800x-800/59b7cdd3e7d13_screenshot_20170912-130310.jpg)

Finger touching screen. (2012). Technology new worl.

<http://technologynewworl.blogspot.nl/>

Analog volume. (2016). Kirby Hamilton, Getty Images

[https://fthumb.tqn.com/VuHsfsiz6rdliQa9bItatAxwCk-M=/3872x2463/filters:no\\_upscale\(\):fill\(FFCC00,1\)/GettyImages-173753190-57bba13a5f9b58cdfd8470ee.jpg](https://fthumb.tqn.com/VuHsfsiz6rdliQa9bItatAxwCk-M=/3872x2463/filters:no_upscale():fill(FFCC00,1)/GettyImages-173753190-57bba13a5f9b58cdfd8470ee.jpg)

Race car. (2012). Fondos y pantallas.

[https://www.fondosypantallas.com/wp-content/uploads/2012/10/Re-nault\\_F1\\_104\\_1920x1200.jpg](https://www.fondosypantallas.com/wp-content/uploads/2012/10/Re-nault_F1_104_1920x1200.jpg)

Narrow corridors. (2013). Bridge publications.

[http://f.edgesuite.net/data/www.bridgepub.com/files/BRIDGE-004\\_0.jpg.crop\\_display.jpg](http://f.edgesuite.net/data/www.bridgepub.com/files/BRIDGE-004_0.jpg.crop_display.jpg)

Forklift HELI. Back view of the vehicle

<http://www.heliforklift.ca/images/fiches/documents/ac-1-5ton-rwd-new-brochure.pdf>

Lifting a box. (2003). Sei80.

[https://familydoctor.org/wp-content/uploads/2000/08/shutterstock\\_331056329-705x470.jpg](https://familydoctor.org/wp-content/uploads/2000/08/shutterstock_331056329-705x470.jpg)

Bekant table (Ikea). (2014). Xombit

<https://xombit.com/files/2014/10/mesa-bekant.jpg>

# APPENDIX

## Tangible user interfaces. Projects 2012. Copenhagen institute of interaction design



### Omnion

Shake it to change the song.

Turn the upper part to control de volume, the brightness of the light show the volume's level.

The shape guides you in how to use it, how to handle it.

You can record your own gestures.



### Skube

Flipping it is the way of changing its mode: Playlist / Explore

You can connect more speakers together, making them fit to each other. The irregular shape shows you how they should be positioned.



# APPENDIX

past.fm

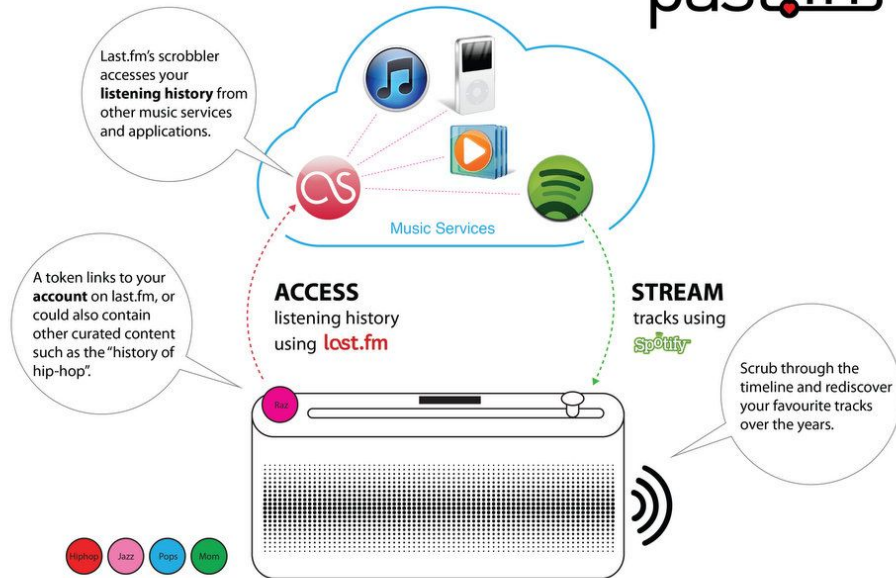

## Past.fm



### Jarlene

Taking off the top and holding jarlene near a music source captures the music. It's like you are opening a bottle to introduce music and keep it inside. Richhh

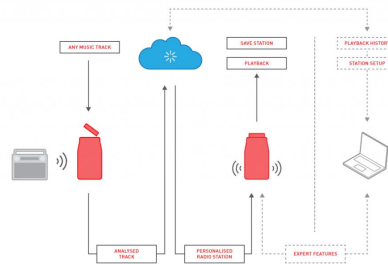

# APPENDIX

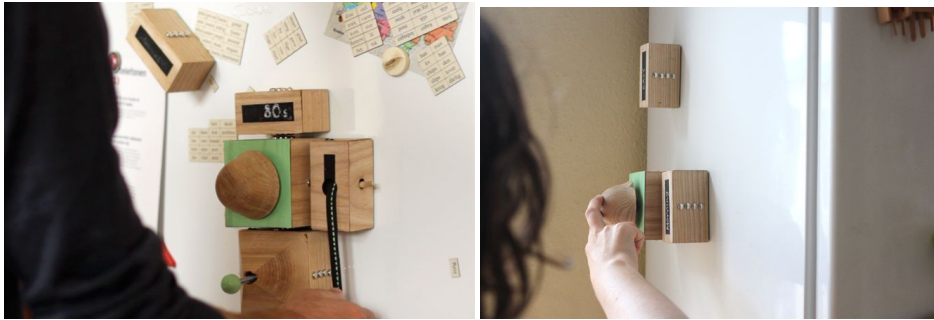

## Frijlets

The form-factor of each Frijlet echos its function: play/pause/volume is both button and knob; shuffle is a globe that actually requires shaking; and skip/previous is a bobble you push forward or backward

[http://www.maxmeulendijks.nl//\\_possible\\_unsafe\\_site](http://www.maxmeulendijks.nl//_possible_unsafe_site)

Max Meulendijks. TU eindhoven

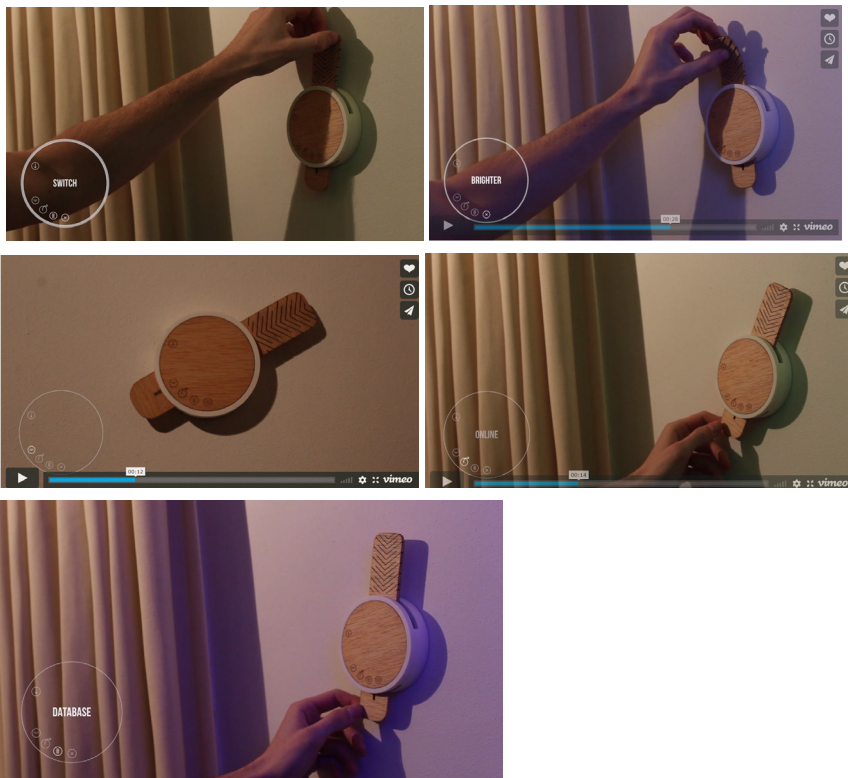

Rotating the stick



# APPENDIX

flexible stick, you can bend it.



Skal from Timo

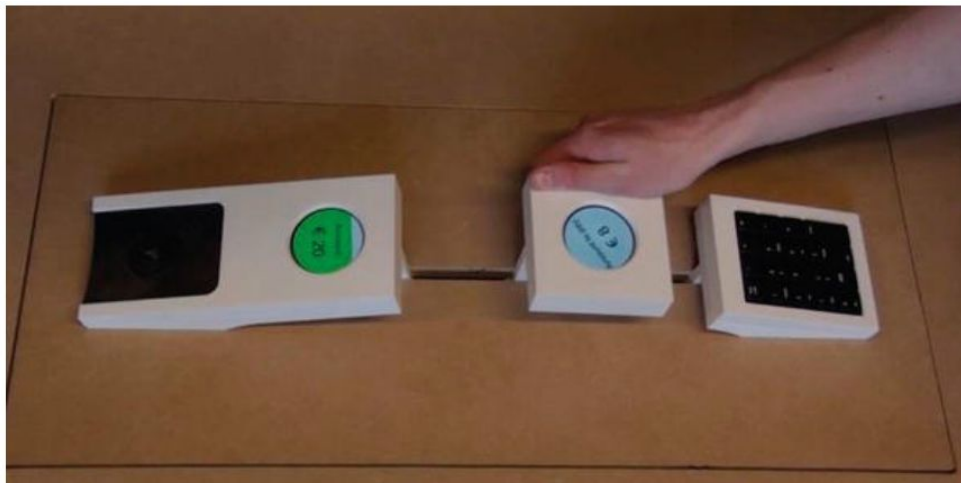

FIGURE 2.

Third stand payment terminal by Lukas van Campenhout [25, 26]. (Photo courtesy of Lukas van Campenhout.).

Payment method. You push the quantity to the other device

## APPENDIX

<https://www.intechopen.com/books/proceedings-of-the-conference-on-design-and-semantics-of-form-and-movement-sense-and-sensitivity-desform-2017/designing-for-embodied-and-rich-interaction-in-home-iot>

Research about: **Designing for Embodied and Rich Interaction in Home IoT**  
Very interesting.

<https://vimeo.com/205019915>

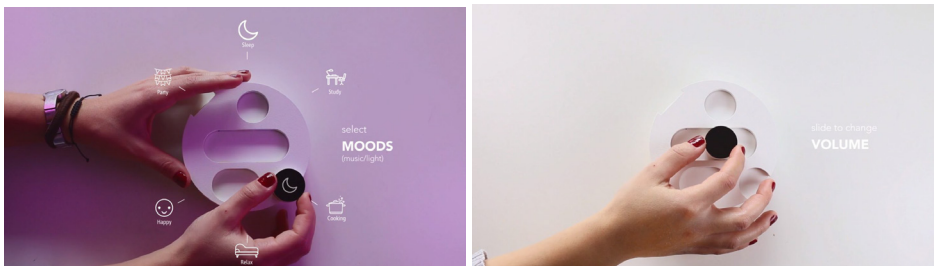

Designing for rich interaction in growing IoT - Yijun Yu

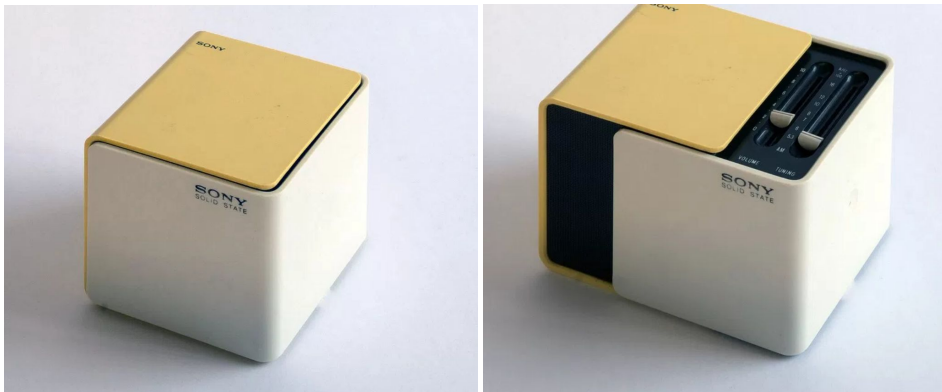

**SONY cube radio TR-1825K**

## APPENDIX

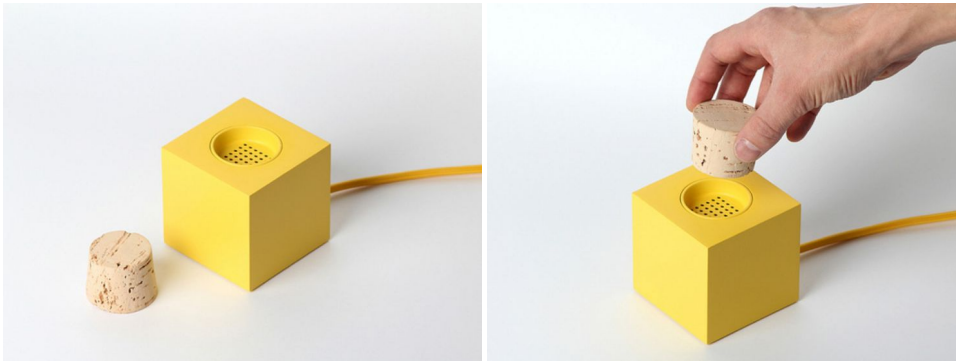

**Plugg radio by Skrekkøgle**

They use the physical act of stopping a cork as its on/off mechanism.

---



**Fan Flow - Simona Hruskova**

Ventilador



**Smart Alarm Clock Design - Hojung Cha**

2 positions

---



**Daisy - Lenneke Wispelwe**

## APPENDIX

Textures.. stripes only where you have to turn it

---

<https://www.pinterest.com.mx/pin/488148047097732228/>

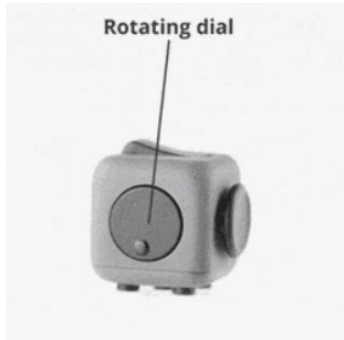

**Fidget cube** - Matthew and Mark McLachlan  
Examples of different kind of buttons, gears, joystick ...

---

<https://www.pinterest.com.mx/pin/488148047097180724/>



**Obake** - Dhairya Dand + Rob Hemsley  
2.5D screen, not 2D and rigid as they are always. It's elastic, you can pull it, push it ... they shape will change when deforming it.

---

<https://www.pinterest.com.mx/pin/488148047097122306/>

