

Document downloaded from:

<http://hdl.handle.net/10251/197322>

This paper must be cited as:

Xu, F.; Tsunogawa, H.; Kako, J.; Hu, X.; Eben Li, S.; Shen, T.; Eriksson, L.... (2022). Real-time energy optimization of HEVs under-connected environment: a benchmark problem and receding horizon-based solution. *Control Theory and Technology*. 20:145-160.  
<https://doi.org/10.1007/s11768-022-00086-y>



The final publication is available at

<https://doi.org/10.1007/s11768-022-00086-y>

Copyright Springer-Verlag

Additional Information

# Real-time Energy Optimization of HEVs under Connected Environment: ECOSM 2021 Benchmark Problem and a Case Study

Fuguo Xu<sup>a,\*</sup>, Hiroki Tsunogawa<sup>b</sup>, Junichi Kako<sup>b</sup>, Xiaosong Hu<sup>c</sup>, Shengbo  
Eben Li<sup>d</sup>, Tielong Shen<sup>a</sup>, Lars Eriksson<sup>e</sup>, Carlos Guardiola<sup>f</sup>

<sup>a</sup>*Department of Engineering and Applied Sciences, Sophia University, Tokyo 102-8554,  
Japan*

<sup>b</sup>*Higashi-Fuji Research Center, Toyota Motor Corporation, Shizuoka 410-1107, Japan*

<sup>c</sup>*The State Key Laboratory of Mechanical Transmissions, Chongqing University, Chongqing  
400044, China*

<sup>d</sup>*The State Key Lab of Automotive Safety and Energy, Tsinghua University, Beijing  
100084, China*

<sup>e</sup>*Vehicular Systems, Dept. Electrical Engineering, Linköping University, SE-581 83  
Linköping, Sweden*

<sup>f</sup>*Departamento de Máquinas y Motores Térmicos, Universitat Politècnica de València,  
46022 Camino de Vera s/n, Valencia, Spain*

---

## Abstract

This paper proposes a benchmark problem for the challengers aiming to energy efficiency control of hybrid electric vehicles (HEVs) on a road with slope. Moreover, it is assumed that the targeted HEVs are in the connected environment with obtainment of real-time information of vehicle-to-everything, including geographic information, vehicle-to-infrastructure information and vehicle-to-vehicle information. The provided simulator consists of an industrial-level HEV model and a traffic scenario database obtained through a commercial traffic simulator, where the running route is generated based on real-world data with slope and intersection position. The benchmark problem to be solved is the HEVs powertrain control using traffic information to fulfil fuel economy improvement while satisfying the constraints of the driving safety and travel time. To show the HEV powertrain characteristics, a case study is given with the speed planning

---

<sup>\*</sup>Fully documented templates are available in the elsarticle package on CTAN.

<sup>\*</sup>Corresponding author

*Email address:* `fuguoXu@eagle.sophia.ac.jp` (Fuguo Xu)

and energy management strategy.

*Keywords:* Powertrain control, Connected and automated vehicles, Hybrid electric vehicles, Vehicle-to-everything

*2010 MSC:* 00-01, 99-00

---

## 1. Introduction

Since the first hybrid electric vehicle (HEV) was launched onto the automotive market in 1997, HEV has been widely known as a green-energy car. The hybrid electric vehicle is a vehicle powered by a combination of battery-electric  
5 motors and an internal combustion engine. This combination enables the combustion engine not only operating at most efficient and green operating area, but also pre-planning the energy flow according to the driving route. During the last two decades, a large number of researches have been reported to explore the potential of HEVs in energy saving. From the view of powertrain control and  
10 management technology, the key issue is the energy management strategy that is implemented in the onboard control unit and delivers the commands to the power sources of powertrain according to the state of the powertrain and the power demand of the driver [1, 2]. However, most researches addressed this issue from system control are preplanning-based optimization schemes that seek the solu-  
15 tion for optimal energy consumption under the assumption of the power demand profile of the whole driving route to be previously known [3, 4, 5]. Although real-time optimization has been focused many attentions that challenge the energy consumption optimization problem without complete pre-information in [6, 7, 8], there still exists a gap between the onboard optimization technology  
20 and used in mass production HEVs.

A bottleneck to fill this gap is the variety and the uncertainty in drivers power demand in future period of driving trip, however, that is necessary to be previously known when one solve the energy consumption minimization problem with the existing methods proposed in the literatures. Therefore, further challenging  
25 in real-time optimization of energy consumption is still an open issue in power-

train control community. A new milestone is greatly anticipated by breaking the bottleneck not only from automotive industry but also the academic community of energy system and optimization. Fortunately, the connectivity progressed very recently provided a big opportunity in developing innovative technology of onboard optimization of energy consumption, since the real-time communication between vehicle-to-vehicle (V2V), vehicle-to-infrastructure (V2I) provides possibility in seeking the optimal solution. Indeed, many attempts have been reported to challenge the problem. For example, the future vehicle speed used for the energy management strategy is predicted through a chaining neural network with communication of V2V and V2I [9]. Further, the demand driver torques in the prediction horizon for receding horizon-based energy management are estimated through the predictors of extreme learning machine and Gaussian process regression, respectively [10, 11]. On the other hand, the technologies of connectivity and automated driving make it possible to jointly optimize the powertrain operation and vehicle dynamics for HEVs to improve the fuel economy further [12, 13, 14, 15].

The aim of this article is to propose a benchmark problem of real-time energy management strategy design for HEVs under the connected environment, which is developed for student competition in the 6th IFAC Conference on Engine and Powertrain Control, simulation and Modeling (E-COSM), Tokyo 2021. The purpose of the benchmark problem is to provide a platform for the students and younger researchers to challenge the issues of the next generation powertrain control, and exchanging the frontier research results in automotive system control and optimization. The benchmarking issues will be presented and detailed explanation of the provided simulation testing platform will be explained with the technical parameters. As a case study, a receding horizon optimization-based strategy is presented with the evaluating test results. Furthermore, evaluation method for benchmarking results will be presented, and the schedule of the benchmark competition of IFAC E-COSM 2021 can be found in the Appendix.

The rest of this paper is organized as follows. Section 2 proposes the bench-

mark problem focusing on the minimization of fuel consumption on a route of fixed initial and terminal points with satisfaction of serval constraints. The detail introduction of provided simulator, and the model description of powertrain and the available data of V2X are given in Section 3. Then the explanation of benchmark tasking and evaluation are given in Section 4. A case study of the powertrain control for the targeted HEV is conducted to show the characteristics of HEV powertrain in Section 5. Finally, the conclusion of the benchmark is conducted in Section 6.

65 **2. Benchmark Problem**

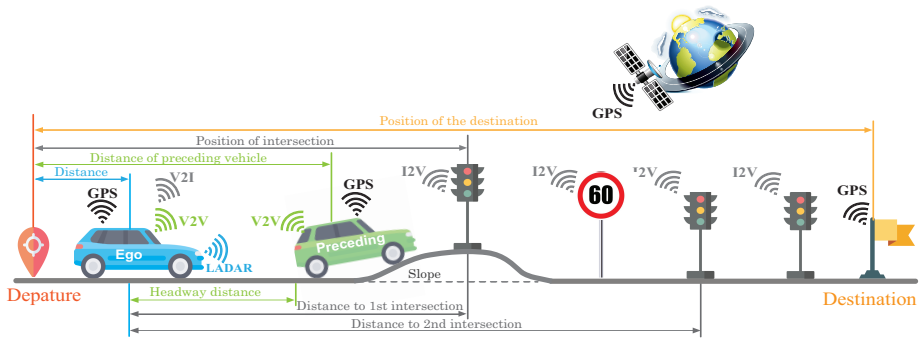

Figure 1: The framework of the vehicle in connected environment.

The framework of vehicles in the connected environment is sketched in Fig. 1 where the connected vehicles are enabled to communicated with GPS, V2V and V2I during the trip. For example, the V2I information, such as traffic light phase and timing, the distance to the next intersection can be obtained for ego vehicle. The distance headway between ego vehicle and the preceding vehicle should be considered for the driving safety and it is available to ego vehicle equipping the distance detecting sensor. The preceding vehicle information, such as distance, speed and acceleration, is transmitted to ego vehicle through the V2V. In the road, the maximum speed limit based on traffic rule is also considered. The targeted road for this benchmarking is shown in Fig. 2, which

is a montanic town area and the running route is highlighted by a white line. The data of height and slope along the route is obtained by automotive road tests and the profiles are shown in Fig. 3. When the departure and destination points in the road for ego vehicle are determined, the slope and position of the intersection along the road can be pre-known through GPS information.



Figure 2: The map showing the location of the road in the benchmark problem obtained from Google Maps.

The targeted vehicle is a passenger hybrid electric vehicle with power split hybrid system and produced by Toyota Motor Corporation. The structure of power-split powertrain system consisting of engine, motor, generator and planetary gear is shown in Fig. 4, where ENG, MG1 and MG2 denote the engine, generator and motor, respectively. An engine, a generator and a motor are mechanically connected to the carrier gear, sun gear and ring gear of the planetary gear, respectively. Both MG1 and MG2 are also connected to the battery electrically. The control inputs of the powertrain are torques of engine, motor and

generator, and a mechanical braking force is used to compensate the insufficient  
 90 generative force by the motors. The detail meanings of the parameters in Fig.  
 4 is described in Table. 1 and the values of these parameters are listed in Table.  
 2.

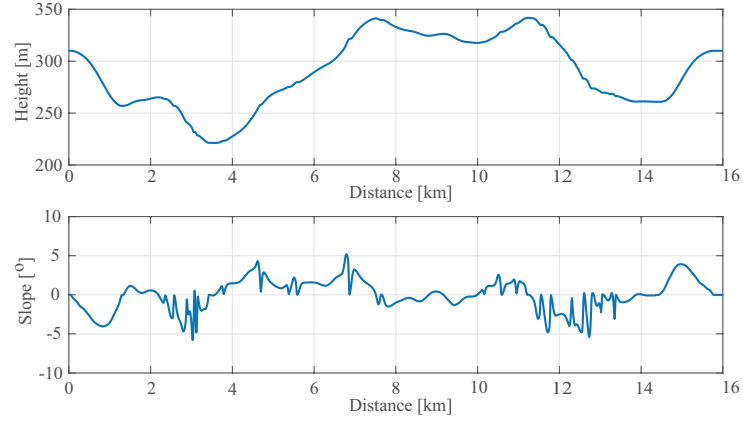

Figure 3: The height and slope information of the road.

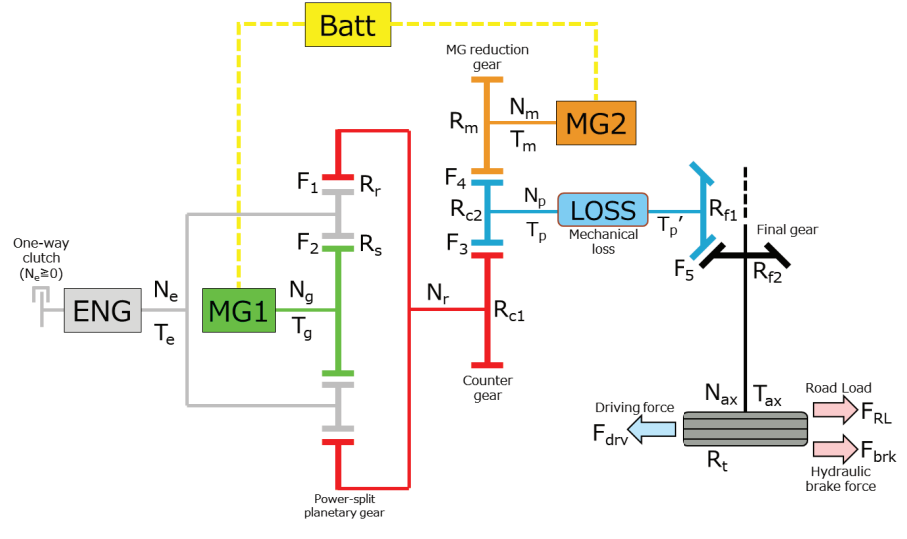

Figure 4: The structure of power-split HEV.

Table 1: The meaning of parameters

Parameter	Description	Parameter	Description
$R_r$	Ring gear radius	$R_s$	Sun gear radius
$R_m$	MG reduction gear radius	$R_{c_{1,2}}$	Carrier gear radius
$R_{f_{1,2}}$	Final gear radius	$R_t$	Tire radius
$I_c$	Inertia of engine and carrier	$I_g$	Inertia of MG1 and sun
$I_m$	Inertia of MG2 and reduction	$I_p$	Inertia of pera-shaft
$I_t$	Inertia of tire and drive-shift	$T_e$	Engine torque
$T_m$	MG2 (motor) torque	$T_g$	MG1 (generator) torque
$T_{p,p}$	Pera-shift torque	$T_{ax}$	Driving torque on tire
$N_e$	Engine speed	$N_m$	MG2 (motor) speed
$N_g$	MG1 (generator) speed	$N_p$	Pera-shift speed
$N_{ax}$	Tire speed	$F_{drv}$	Driving force
$F_{RL}$	Road load	$F_{brk}$	Hydraulic brake force

Table 2: The values of parameters

Parameter	Value [Unit]	Parameter	Value [Unit]
$I_e$	0.142 [ $kgm^2$ ]	$R_s$	30 [mm]
$I_m$	0.0074 [ $kgm^2$ ]	$R_r$	78 [mm]
$I_g$	0.0154 [ $kgm^2$ ]	$R_m$	17 [mm]
$I_t$	3.12 [ $kgm^2$ ]	$R_{c1}$	65 [mm]
$Q_{batt}$	23.275 [Ah]	$R_{c2}$	53 [mm]
$R_t$	634.5 [mm]	$R_{f1}$	19 [mm]
$M$	1700 [ $kg$ ]	$R_{f2}$	75 [mm]

The goal of the benchmark problem is to develop an on-board optimal energy management strategy for the targeted HEV that minimizes the total fuel con-



95 supmption when the vehicle finishes the trip along the given route but randomly  
 generated traffic environment. The control scheme proposed by the challengers  
 should drive the vehicle and manage the fuel consumption at the same time, but  
 it is not permitted to overtaking the preceding vehicle. The detailed constraints  
 and competition rules will be presented in the following sections.

### 100 3. Provided Simulation Platform

#### 3.1. Simulator

The key structure of the provided simulator is shown in Fig. 5, including  
 the traffic scenario, the controller and imitating the dynamics of powertrain and  
 the vehicle.

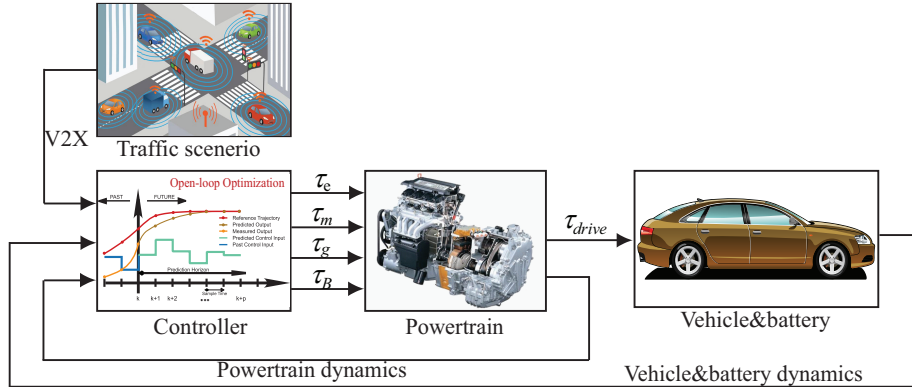

Figure 5: The structure of provided simulator.

105 The overview of the simulator is shown in Fig. 6, which mainly consists of  
 three blocks: the Traffic Scenario, the Controller and the Plant Model, where  
 the controller block is free for challengers to equip their won control scheme.  
 Moreover, there is also a block of Index Performance, which is used to calculate  
 the index values. The block of Total Fuel Calculation is used to calculate the  
 110 total fuel consumption, which converts the electricity consumption to fuel con-  
 sumption through an equivalent factor. The block of Index Display is used to  
 show the index values.

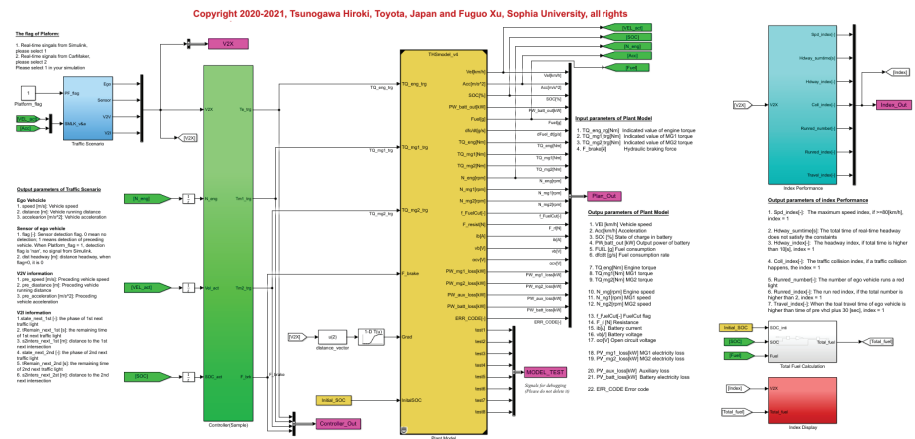

Figure 6: The overview structure of provided simulator.

### 3.1.1. Plant model

It is noted that the powertrain and vehicle are combined in an encrypted module and the challengers can not open it, named as *Plant Model*. It is noted  
115 that the challengers that this simulator can only run in MATLAB 2018a. The inputs of this module are commands of engine torque, motor torque, generator torque and the mechanical braking force, which should be the outputs of the controller designed by the challengers. The detail descriptions of output signals  
120 of *Plant Model* are listed in Table. 3.

Table 3: The meaning of output signals

Parameter	Description	Unit
$VEL$	Vehicle speed	$km/h$
$Acc$	Acceleration	$m/s^2$
$SOC$	state of charge	%
$PW\_batt\_out$	Battery output power	$kW$
$FUEL$	Fuel consumption	$g$
$dfc/dt$	fuel consumption rate	$g/s$
$TQ_{eng}$	Engine torque	$Nm$
$TQ_{mg1}$	MG1 torque	$Nm$
$TQ_{mg2}$	MG2 torque	$Nm$
$N_{eng}$	Engine speed	$rpm$
$N_{mot1}$	MG1 speed	$rpm$
$N_{mot2}$	MG2 speed	$rpm$
$f_{FuelCut}$	Fuel cut flag	–
$F_{rt}$	Resistance	$N$
$ib$	battery current	$A$
$vb$	battery voltage	$V$
$ocv$	open circuit voltage	$V$
$PW\_mg1\_loss$	MG1 electricity loss	$kW$
$PW\_mg2\_loss$	MG2 electricity loss	$kW$
$PW\_aux\_loss$	Auxiliary loss	$kW$
$PW\_batt\_loss$	Battery electricity loss	$kW$
$ERR.CODE$	Error code	–

### 3.1.2. Traffic scenario

There are four parts in the block of the Traffic Scenario, including the Ego vehicle information, the Sensor information, the V2V information and the V2I information, as is shown in Fig. 7. When the Platform flag is selected as 1,

125 which means the real-time vehicle information from Simulink, the block of ego vehicle information is not activated actually.

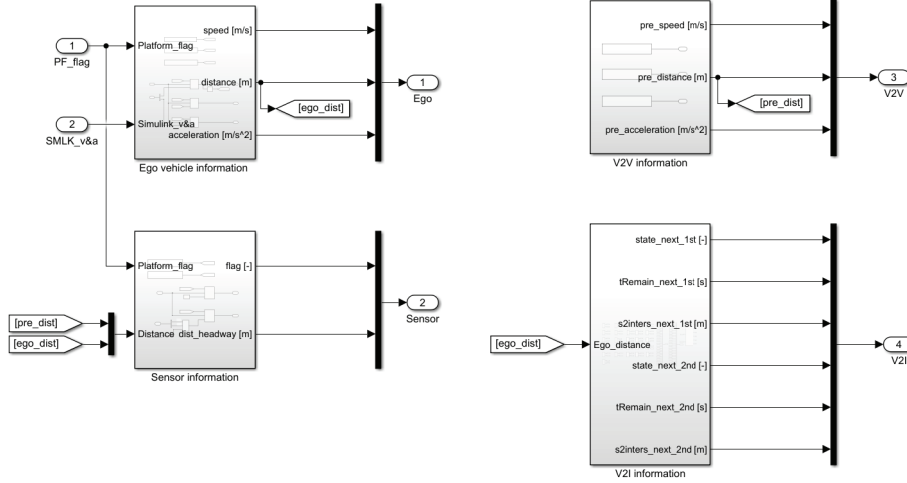

Figure 7: The structure in the block of traffic scenario.

### 3.1.3. Controller

For the sample controller, only signals of engine speed, vehicle speed, *SOC* from the *Plant Model* and V2X information from the Traffic Scenario are given to this block. The challenger can design your own scheme in this block and it is possible to use any output signal of *Plant Model* and any signal of the V2X without hesitate.

### 3.1.4. Index performance

In the block of Index Performance, there are four subblocks, including speed limitation, Traffic collision, Distance headway Run the light and Total travel time, shown in Fig. 8. These blocks are used to show the indexes that may disqualify the challengers. The detail information of them will be given in the later section.

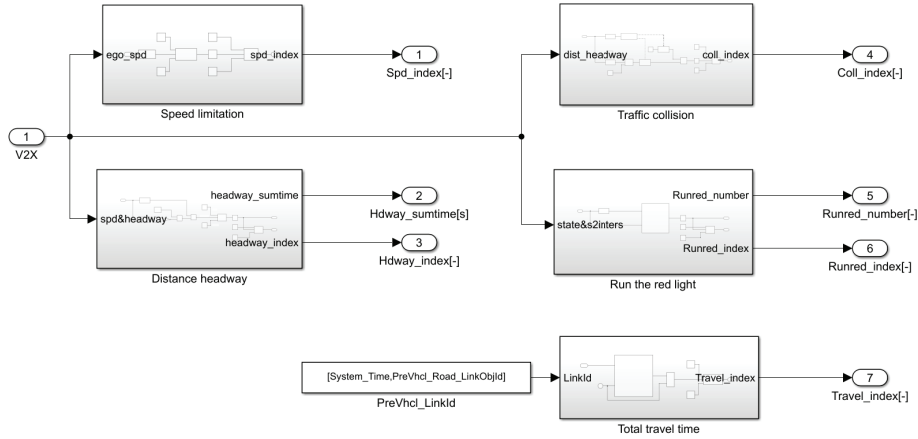

Figure 8: The structure in the block of Index Performance.

### 3.2. Component Model and Physical Parameter

140 In this subsection, the detail models of powertrain and battery, and physical parameter of ego vehicle sensor and V2X are briefly explained, respectively.

#### 3.2.1. Powertrain model

(a) Engine model The fuel consumption rate of engine  $\dot{m}_f$  is dependent on the engine speed  $N_e$  [rpm] and engine torque  $\tau_e$ , which is described as a map  
 145 form, shown in Fig. 9. Moreover, the minimum and maximum of speed and torque for engine are forced. The maximum engine torque is dependent on the engine speed. A negative torque is considered when engine is not ignited. All about information is given in the simulator, where the challengers can obtain it.

(b) Motors model As shown in Fig. 4, there are two motors in this planetary gear structure, which are MG1 and MG2 treated as generator and motor, respectively. The electric powers  $P_i$ ,  $i \in [m, g]$  for motor and generator are related to torque  $\tau_i$  and speed  $\omega_i$ . The electric machines modeling are represented as efficiency maps, shown in (a) and (b) of Fig. 10. The limitation of speed and torque for motors are also forced. Similarly, the maximum and minimum torques of motor and generator are dependent on the speed. For more

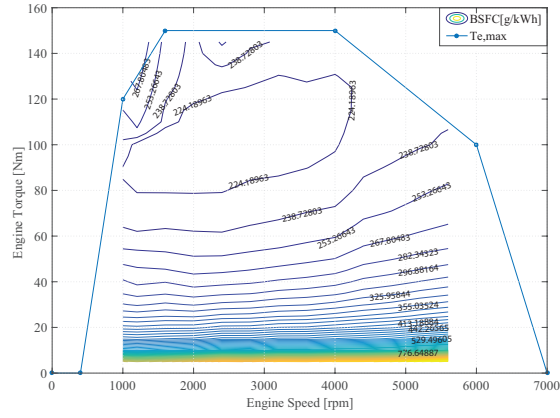

Figure 9: The map of fuel consumption.

information, please see the simulator package. Actually, the power loss is given in the simulator and the relationship between the power loss and efficiencies of the generator and motor can be described as follows:

$$\eta_i = \begin{cases} \frac{\tau_i \omega_i - P_{loss} * 1000}{\tau_i \omega_i}, & \tau_i \omega_i > 0 \\ \frac{\tau_i \omega_i + P_{loss} * 1000}{\tau_i \omega_i}, & \tau_i \omega_i < 0 \end{cases} \quad (1)$$

150 where  $P_{loss}$  is the power loss [kW] in motors, the detail map information dependent on  $\tau$  and  $\omega$  is given in the simulator package.

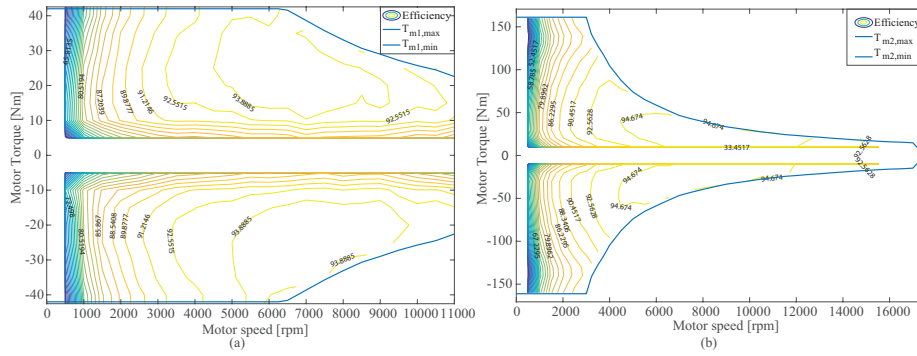

Figure 10: The maps of efficiencies of MG1 and MG2.

(c) Battery model For the goal of controller diversity, this benchmark

does not provide any detail expression of the battery dynamics. However, inner signals of the battery, including battery current, battery voltage and open circuit  
155 voltage, are available in the simulator. Based on these real-time signals, the challenger can build the SOC model of battery by yourselves.

### 3.3. V2X

In the real-world traffic scenario with ability of advanced communication technology, the traffic information is available for the ego vehicle, which mainly  
160 consists of geographical information and traffic participants. In the following part of this section, the information obtained from ego vehicle sensor, geographical equipment and other traffic participants will be introduced, respectively.

#### 3.3.1. Ego vehicle sensor

For ego vehicle equipped with sensor, it is possible to detect the inter distance  
165 between ego vehicle and preceding vehicle. The real-time signals of detection flag and distance headway are provided in the simulator. The detection flag signal 1 and 0 denote detectable and undetectable, respectively. If flag signal is 1, the real-time distance headway is available; otherwise, the value of distance headway is given as 0. The profiles of ego sensor's information in three traffic  
170 scenarios running in the route of Fig. 2 are shown in Fig. 11.

#### 3.3.2. Geographical information

Although the route shown in Fig. 2 is full of turns, it is assumed that the road in this benchmark is a straight one without any turn, but with intersections in the real-world positions and there are traffic lights in these intersections. The ge-  
175 ographical information, including road length, intersections' location and route slope, is assumed to be available for ego vehicle through GPS. In this benchmark, there are 26 intersections along the road; moreover, it is assumed that the vehicles ahead the ego vehicle will be disappeared after the 26th intersection and only ego vehicle runs on the link after 26th intersection, whose length is  
180 195 [m]. The distance of each intersection to departure point is listed in Table. 4. Above geographical information can also be obtained in the simulator.

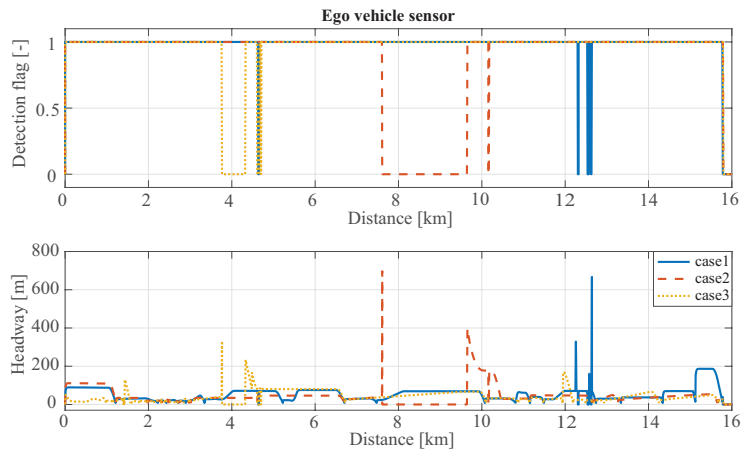

Figure 11: The ego vehicle' sensor information of three traffic cases.

Table 4: The position of intersections

Intersection	Position [m]	Intersection	Position [m]
#1	1288	#14	10162
#2	2358	#15	10575
#3	2572	#16	10948
#4	2886	#17	11201
#5	3066	#18	11537
#6	3150	#19	11781
#7	3422	#20	12302
#8	3784	#21	12587
#9	4696	#22	12785
#10	5377	#23	13032
#11	5576	#24	13368
#12	6855	#25	14364
#13	7626	#26	15807



3.3.3. Traffic participants

(1) For vehicle running in the real-world traffic scenario, the other traffic participants in the same scenario should also be considered, consisting of traffic lights and vehicles ahead the ego vehicle. The real-time position, speed and acceleration of preceding vehicle are available to ego vehicle through V2V communication. The profiles of speed and acceleration of preceding vehicle in three cases are shown in Fig. 12. It is noted that the vehicles ahead the ego vehicle are disappeared after the 26th intersection and only ego vehicle runs to the destination.

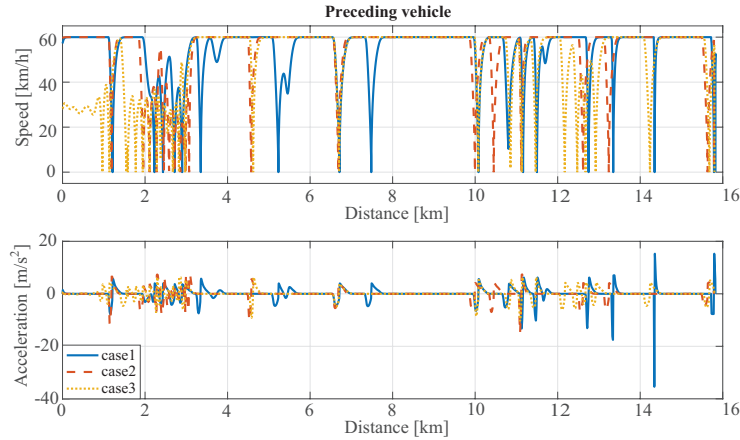

Figure 12: The speed and acceleration of preceding vehicle of three traffic cases.

190

(2) The ego vehicle should follow the rule of traffic light. It is noted that only red and green signals for the traffic light so that it follows the rule that vehicle runs and stops when facing with the green and red signals at the intersection, respectively. There is a traffic light at each intersection and the distance to the intersection (traffic light) is available to the ego vehicle. Moreover, it is noted that the traffic light phase at each intersection is not identical. In this benchmark, the total traffic light information of 10 data is provided in the simulator. But in the simulator, only on-board traffic lights's information of next 2 intersections are available for real-time controller. The phases and remaining

195

200 timings of upcoming 2 traffic lights in three cases are shown in Fig. 13 and Fig. 14, respectively.

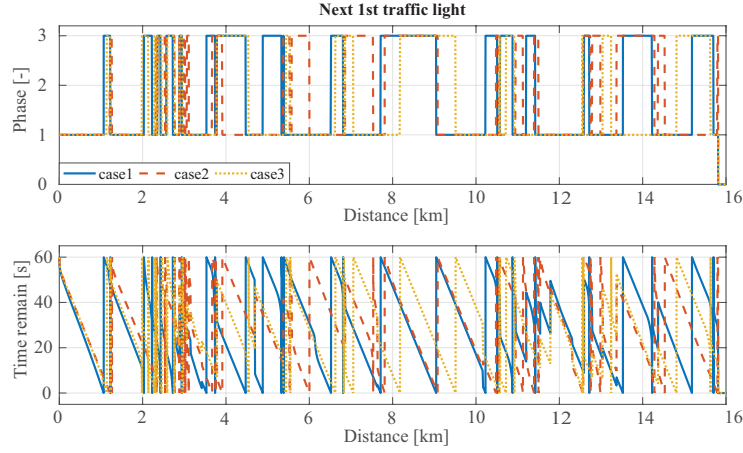

Figure 13: The 1<sup>st</sup> upcoming traffic light's remain timing and phase of three traffic cases.

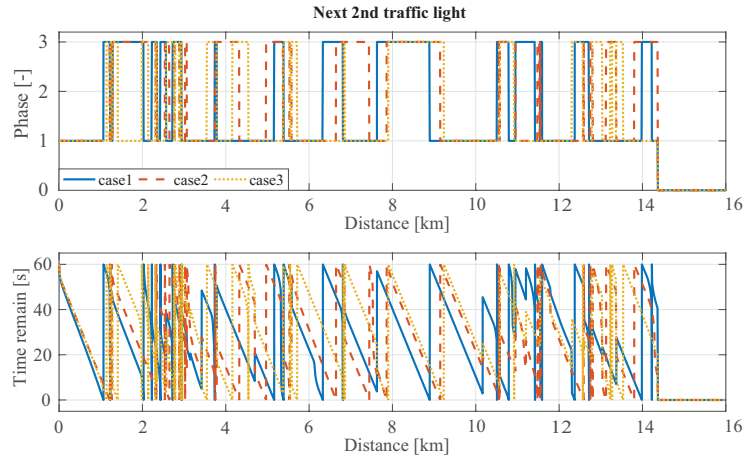

Figure 14: The 2<sup>nd</sup> upcoming traffic light's remain timing and phase of three traffic cases.

In summary, the information of geographical equipment, ego vehicle sensor, V2V and V2I that is available for ego vehicle in the provided simulator for benchmark is listed in Table. 5.

Table 5: V2V and V2I information

Category	Variable	Description
GPS	$x_e$	Distance
	$\theta$	Road slope
	$P_{inter}$	Intersection positions
	$P_{desti}$	Destination positon
Sensor	$s$	Distance headway
	$p_{detec}$	Preceding vehicle detection
V2V	$x_p$	Preceding vehicle distance
	$v_p$	Preceding vehicle speed
	$a_p$	Preceding vehicle acceleration
V2I	$l_{ph,1}$	Traffic light phase of next 1 <sup>st</sup> intersection
	$l_{time,1}$	Traffic light timing of next 1 <sup>st</sup> intersection
	$l_{ph,2}$	Traffic light phase of next 2 <sup>nd</sup> intersection
	$l_{time,2}$	Traffic light timing of next 2 <sup>nd</sup> intersection

205 **4. Challenging and Evaluating**

4.1. *Challenging*

As shown in Fig. 6, the challengers can use the signals from block of *Traffic Scenario* in Table. 5 and the output signals from the block of *Plant Model* in Table. 3. It is noted that the provided signals may be surplus and the  
 210 challengers can discretionarily select some of them for your controller design. But the controller should be set in the *Controller* block. The other blocks, such as Traffic Scenario, Plant Model and Index Performance are not allowed to make any modification.

The task of the benchmark is to design a controller that achieving the min-  
 215 imization of fuel consumption on the route shown in Fig. 1. The real-time dynamic information of powertrain, battery and vehicle are available to the controller. Meanwhile, the real-time traffic scenario information, including ego

vehicle sensor, GPS, V2I and V2V, are also provided to the controller. The challengers can be selective to use above real-time information. Moreover, the safety constraints, including vehicle speed and distance headway between ego vehicle and preceding vehicle should be satisfied. On the one hand, the physical constraints of powertrain, battery and vehicle should be satisfied. On the other hand, the stop constraint when facing a red traffic light at the intersection should be considered. In the following, the above four tasks will be introduced in detail.

#### 4.1.1. Fuel consumption

The main goal is to improve the fuel economy of HEVs in the connected environment under the constraint of travel time. With set of initial and terminal SOC, the goal can be seen as the minimization of fuel consumption of engine. Since the start point and terminal point are fixed, the goal of this benchmark is also to reduce the travel time  $t_f$  in this road. However, overtaking behavior is not allowed in the traffic scenario. To minimize the total fuel consumption is the main objective of this benchmark problem. But, the electricity consumption calculated by the difference between the initial and the terminal SOC will be taken into account to the total fuel consumption mass (see the following section for details).

#### 4.1.2. Physical constraints

The physical limitations of powertrain, including engine, motor and generator, and the battery that the vehicle has to follow are written as follows:

$$\left\{ \begin{array}{l} \tau_{e,min} \leq \tau_e \leq \tau_{e,max} \\ \tau_{m,min} \leq \tau_m \leq \tau_{m,max} \\ \tau_{g,min} \leq \tau_g \leq \tau_{g,max} \\ N_{e,min} \leq N_e \leq N_{e,max} \\ N_{m,min} \leq N_m \leq N_{m,max} \\ N_{g,min} \leq N_g \leq N_{g,max} \\ P_{batt,min} \leq P_{batt} \leq P_{batt,max} \\ SOC_{min} \leq SOC \leq SOC_{max} \end{array} \right. \quad (2)$$

where the minimum and maximum torque of engine, motor and generator are also dependent on corresponding speeds, respectively. And the detail values of other parameters are listed in Table. 6.

Table 6: The values of minimum and maximum parameters

Parameter	Value [Unit]	Parameter	Value [Unit]
$N_{e_{min}}$	0 [rpm]	$N_{e_{max}}$	6000 [rpm]
$N_{m_{min}}$	0 [rpm]	$N_{m_{max}}$	17000 [rpm]
$N_{g_{min}}$	0 [rpm]	$N_{g_{max}}$	11000 [rpm]
$P_{batt_{min}}$	-55 [kW]	$P_{batt_{max}}$	55 [kW]
$SOC_{min}$	10 [%]	$SOC_{max}$	90 [%]

On the other hand, the initial conditions of powertrain, vehicle and battery are also determined:

$$\left\{ \begin{array}{l} x(t_0) = 0 \\ x(t_f) = L \\ SOC(t_0) = SOC_0 \\ v(t_0) = 0 \\ v(t_f) = 0 \\ \omega_e(t_0) = \omega_{e,0} \\ \omega_m(t_0) = \omega_{m,0} \\ \omega_g(t_0) = \omega_{g,0} \end{array} \right. \quad (3)$$

#### 4.1.3. Boundary constraints

(1) The headway distance  $s$  between ego vehicle and preceding vehicle for driving safety should be considered, which is shown as follows:

$$s \geq s_{min} + hv \quad (4)$$

where  $s_{min}$  is the minimum allowed distance headway and  $h$  denotes the driver reaction time.

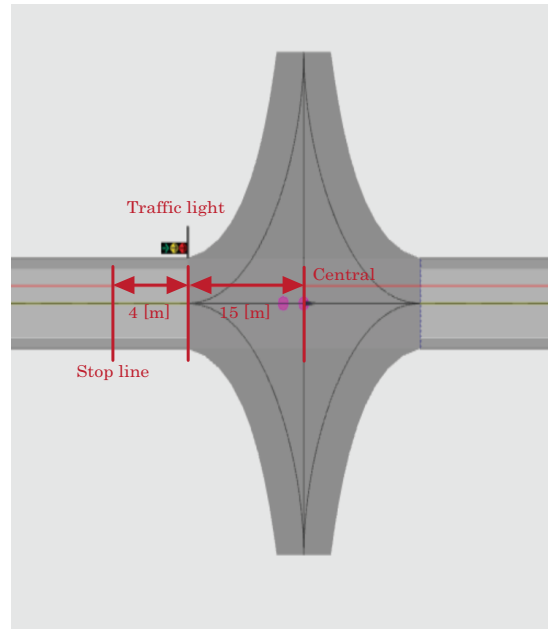

Figure 15: The distances of stop line and the traffic light to the central of intersection.

(2) Since there are traffic lights at the intersection along the route, the vehicle  
 245 should stop before the stop line when the traffic light is in red. In this route,  
 the distance of traffic light to the central of intersection is set as 15 [m] and  
 the distance of stop line to the traffic light is set as 4 [m], as shown in Fig. 15.  
 When the traffic light is red, the vehicle has to stop before 19 [m] to the central  
 of intersection. It is noted that the central of intersection is the end of previous  
 250 link and the start of the new link. If the ego vehicle does not stop before the

stop line when facing with the red light, a punishment time will be added to the actual travel time.

#### 4.2. Evaluating

The materials for submitting benchmarking results is explained in Appendix  
 255 A. When the final controller packages of challengers are received to us, the performance of controllers will be evaluated in other 3 random traffic scenarios, but the road and slope are same as the sample data that have been provided in the public simulator. Mainly, the traffic densities on the links and initial phase and timing of traffic lights in the 3 random traffic scenarios will be different  
 260 from these in the sample data. The championship evaluating process will be conducted through the following items.

##### 4.2.1. Disqualification

The challenger will be disqualified if one of the following rules is broken by the challenger:

- 265 •  $v_i > 60[km/h]$ : Ego vehicle speed is higher than the speed limitation on the road.
- $s_i \leq 0[m]$ : the distance between ego vehicle and preceding vehicle is not higher than 0, that is a case of crush accident.
- $Red_i > 2[-]$ : Ego vehicle runs through intersection during the red light is  
 270 more than 2 times.
- $\sum_j \Delta T_{i,j} > 20[sec]$ : In any test random traffic scenario  $i$ , the total time staying emergency inter-vehicle distance that may cause accident, where at  $j$ -th  $\Delta T_{i,j}$  is the time period that the distance headway between ego vehicle and preceding vehicle, that is headway  $s$  satisfies  $s < kv_e + s_{min}$ .
- 275 •  $T_i > T_{Pre,i} + 60 \times 2 + 30[sec]$ : The travel time of ego vehicle is higher than the travel time of preceding vehicle plus additional 120 [sec].

#### 4.2.2. Scoring

The total fuel consumptions in the 3 testing traffic scenarios are used to obtain the score for each challenger. The fuel consumption and the arriving  
280 time will be evaluated individually with the following methods:

(1) Total fuel consumption

$$F = \sum_{i=1}^3 [m_{fi} + \gamma(SOC_0 - SOC(t_{fi}))] \quad (5)$$

where  $m_{fi}$  and  $t_{fi}$  are the total fuel consumption mass and arriving timing, respectively. When  $SOC_0 - SOC(t_{fi}) < 0$ , there is electric energy saved in the battery;  $SOC_0 - SOC(t_{fi}) > 0$  denotes more electric energy is used for propelling the vehicle. To calculate the fuel consumption accurately,  $SOC_0 -$   
285  $SOC(t_{fi})$  should be transformed to fuel consumption by using the equivalent factor  $\gamma > 0$ .  $i$  indicates the index of testing scenario. Based on the energy consumption of patterns of pure engine and pure motor, the equivalent factor  $\gamma$  is set as 25.

(2) Travel time

$$T_i = t_{fi} + Red_i \quad (6)$$

290 where the second term is penalty for red light crossing, which means each time of red light crossing would plus additional 60 [sec].

With satisfaction of the physical and boundary constraints that are shown in subsections of Section 5 and removing the disqualified challengers, the championship goes to the one challenger with least total fuel consumption in the rest  
295 challengers.

## 5. Case Study

### 5.1. Proposed control scheme

The block diagram of the control scheme for this case study is shown in Fig. 16. Based on the traffic scenario, a speed planning algorithm is used to obtain



300 the optimal reference speed. This algorithm is achieved by the IPG CarMaker, where the flowchart of this algorithm is shown in Fig. 17. The reader can obtain more detail information of this speed planning algorithm in the User Manual Version 7.1.1 IPGDriver.

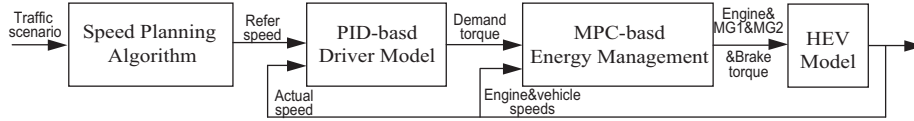

Figure 16: The block diagram of the control scheme in case study.

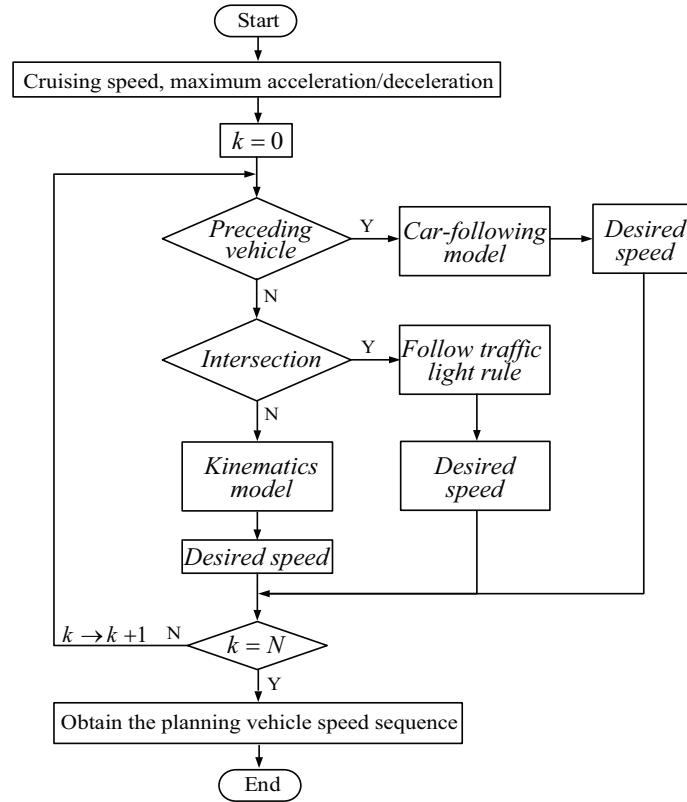

Figure 17: The flowchart of the vehicle speed planning.

With the difference between reference speed and the actual speed, a PID-

305 based driver model is used to derive the demand torque. In the Model Predictive Control (MPC) based energy management strategy, the predictive horizon is set as 8 steps and the sampling time is 0.1 [sec]. It is noted that without prediction of demand torque, the further torques in the prediction horizon are set as same as the current one. The state variables for energy management strategy are  
 310 vehicle speed and engine speed with consideration of the powertrain motion. The control inputs are set as engine torque and generator torque. Then the motor torque can be calculated under determination of demand torque, engine torque and generator torque. Moreover, the braking mechanical force is determined through a rule-based controller. The readers can find more detail information  
 315 about the energy management strategy in Ref. [11].

The designed energy management strategy consists of driving mode decision and MPC-based controller. In the driving mode decision, the modes between EV (energy generation in the braking scenario) and HEV are determined through the demand torque from driver  $\tau_{dr}$ , shown as follows:

$$\begin{cases} EV \text{ mode}, & \tau_{dr} < 0 \\ HEV \text{ mode}, & \text{otherwise} \end{cases} \quad (7)$$

In the HEV mode, to reduce the computation burden, the MPC-based controller is only activated when the the demand acceleration reaches a specific value, which is seen as the driver demand torque reaches a specific value. For the MPC-based controller, the goal is to minimize the energy consumption in  
 320 monetary sense, including the fuel consumption and electricity consumption. Meanwhile, the tracking performance is considered between the actual engine speed and the optimal engine speed  $\omega_{e,d}$  that is derived through the optimal line of engine torque and engine speed. The constrained optimal control problem is formulated as follows:

$$\min_{[\tau_e, \tau_g]^T} J = \int_t^{t+\Delta TN_f} \left\{ [\gamma \dot{m}_f(s) + \beta \dot{m}_e(s)] + \alpha [\omega_e(s) - \omega_{e,d}(s)]^2 \right\} ds \quad (8)$$

$$s.t. \begin{cases} \dot{v}(s) = F(\tau_e(s), \tau_g(s), v(s)) \\ \dot{\omega}_e(s) = G(\tau_e(s), \tau_g(s), v(s)) \\ \tau_{e,\min} \leq \tau_e(s) \leq \tau_{e,\max} \\ 0 \leq \tau_m(s) \leq \tau_{m,\max} \\ \tau_{g,\min} \leq \tau_g(s) \leq \tau_{g,\max} \\ 0 \leq v(s) \leq v_{\max} \\ \tau_{dr}(s) = a_1\tau_e(s) + a_2\tau_m(s) + a_3\tau_g(s) \end{cases} \quad (9)$$

325 where  $\Delta T$  and  $N_f$  are the sampling time and the prediction step, respectively.  $\dot{m}_f$  and  $\dot{m}_e$  are the consumption rates of fuel and electricity;  $\gamma$  and  $\beta$  are the prices of fuel and electricity and  $\alpha$  is the weight factor. Functions  $F$  and  $G$  are the dynamic equations of vehicle speed and engine speed, the detail expressions can be obtained in Ref. [11]. The state variables and control inputs are selected  
 330 as  $x = [v, \omega_e]^T$  and  $u = [\tau_e, \tau_g]^T$ , respectively. In HEV mode, the torques of engine, motor and generator should satisfy the driver demand torque in the last equation of Eq. 9, where  $a_i$ ,  $i = 1, 2, 3$  are the parameters. When the  $\tau_{dr}$ ,  $\tau_e$  and  $\tau_g$  are determined, the motor torque  $\tau_m$  can be calculated.

### 5.2. Simulation Validation

335 The simulation results in case 1 are shown in Fig. 18–Fig. 21. In Fig. 18, it is shown that the actual speed can track the demand speed well; however when there is high acceleration demand at the high vehicle speed, the tracking performance is not that good because of the powertrain performance limitation. Fig. 19 and Fig. 20 show the torques and speeds of engine, generator and motor,  
 340 it can be concluded that the torque and speed can satisfy the powertrain physical constraints. The fuel consumption in engine and electricity consumption in battery (SOC) in case 1 are also shown in Fig. 21. Since the SOC dynamics in the energy management strategy proposed by Ref. [11] is not considered in the optimal control problem, the terminal SOC is relative low.

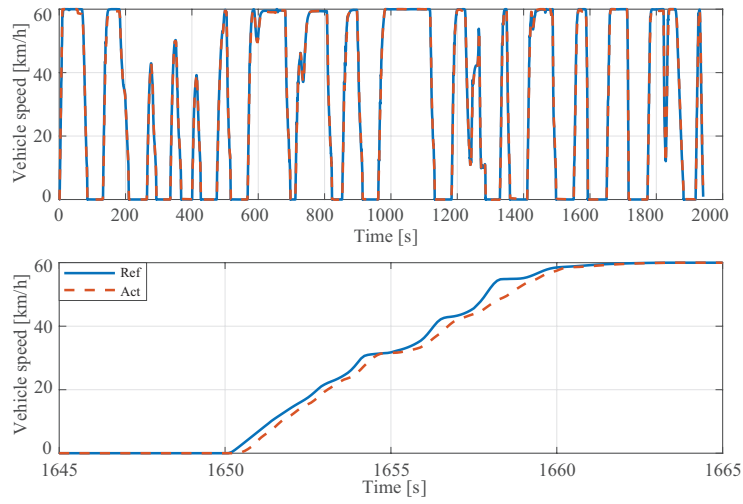

Figure 18: The vehicle speed in case 1.

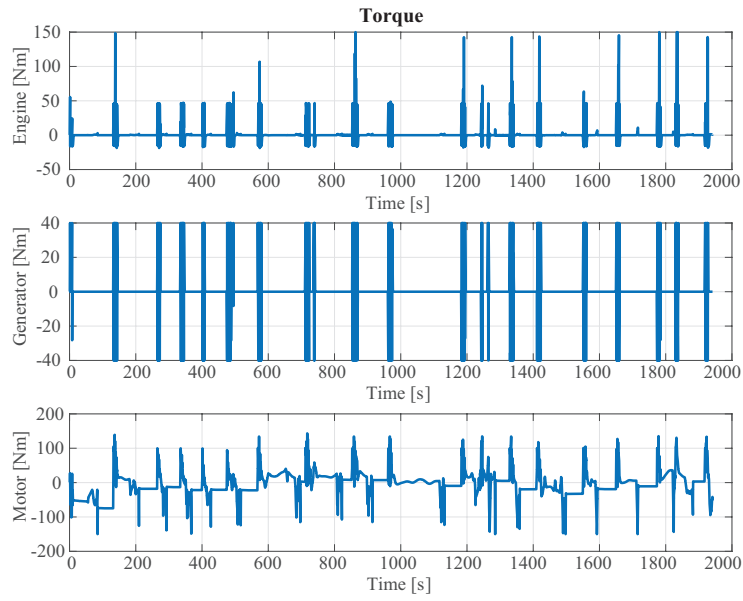

Figure 19: The torques of engine, generator and motor in case 1.

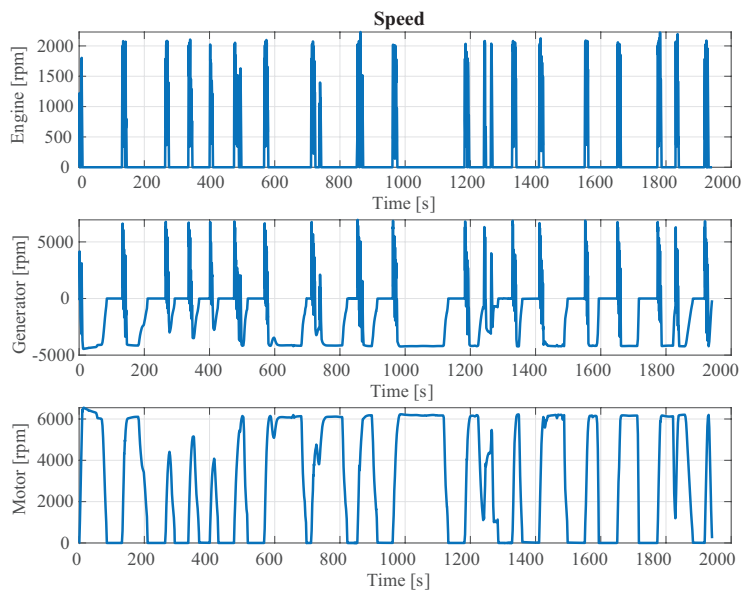

Figure 20: The speeds of engine, generator and motor in case 1.

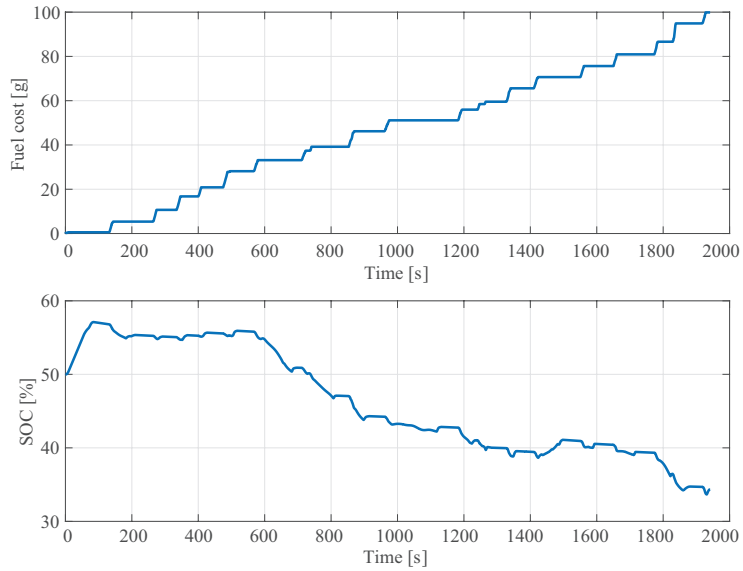

Figure 21: The curve of SOC in case 1.

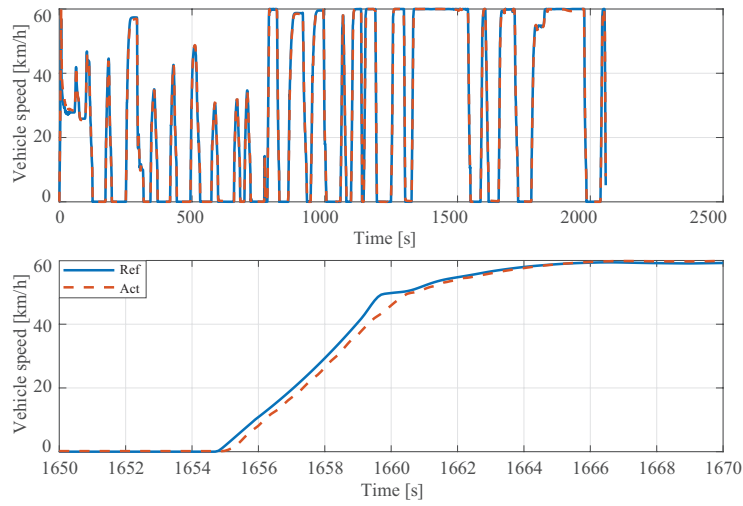

Figure 22: The vehicle speed in case 2.

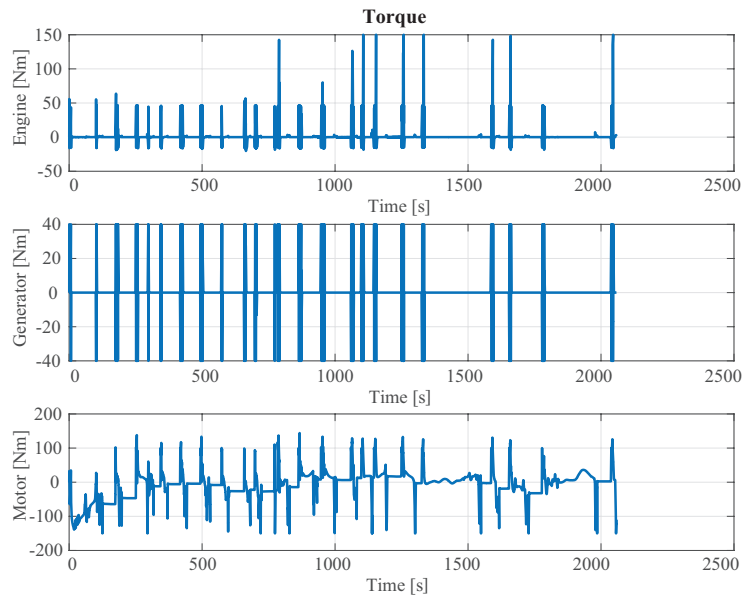

Figure 23: The torques of engine, generator and motor in case 2.

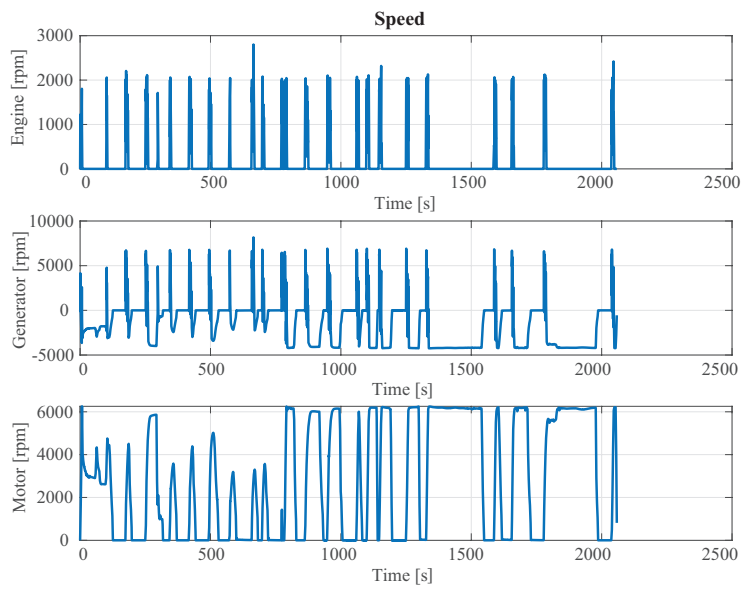

Figure 24: The speeds of engine, generator and motor in case 2.

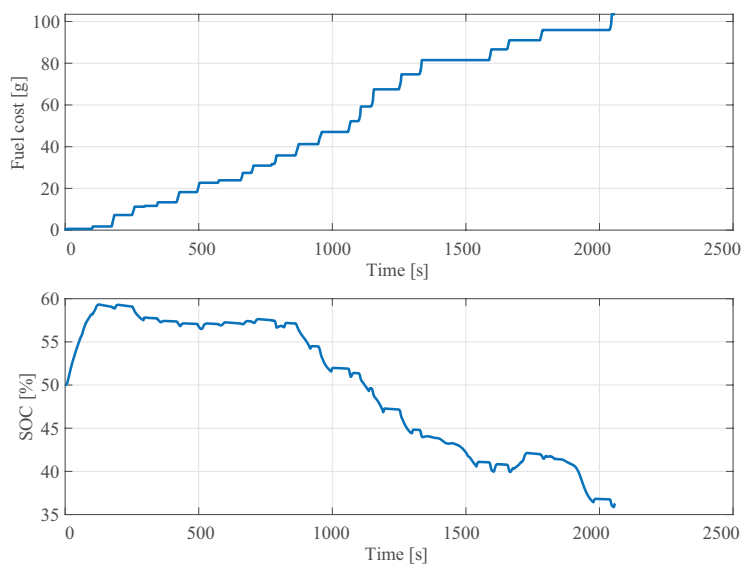

Figure 25: The curve of SOC in case 2.

345 Moreover, the simulation results in case 2 are also shown in Fig. 22–Fig. 25

and the similar conclusions can be obtained through these results. The performance comparison under different cases are given in the Table. 7, including fuel consumption, terminal SOC and total travel time.

Table 7: The performance comparison under different cases

Case	Fuel cost [g]	Terminal SOC [%]	Travel time [s]
#1	99.8646	34.3336	1947.3
#2	83.8881	33.2546	2295.5
#3	83.0784	34.1099	1862.5
#4	102.3738	33.4603	2194
#5	99.5338	36.2813	1919
#6	100.4878	35.9957	2081.6
#7	103.4882	36.2937	2058.1

### 5.3. Discussion

350 (1) It is seen that the control scheme in this case study includes two layers. In the first layer the vehicle dynamics is optimized and the powertrain operation is controlled in the second layer. However, the planning vehicle speed in the first layer does not consider the physical limitation of powertrain. When the vehicle speed is high, the high acceleration demand can not be achieved even  
 355 though both engine and motor work in maximum torque states, shown in the lower curve of Fig. 18 and Fig. 22. So the optimization of vehicle dynamics and powertrain operation jointly is very important or in the planning of vehicle speed, the powertrain constraints, such as maximum engine torque (dependent on engine speed), should be taken into account. It is noted that the control  
 360 scheme in the case study is only used to show the problem of the benchmark. The designed control scheme by the challengers can actually be any form.

(2) In the optimal control problem of the case study, the SOC dynamics and the terminal SOC are not considered so that the terminal SOC is free and it is lower than the initial SOC in this case study. So there are electric energy from



365 battery is used to propel the vehicle. The additional electricity consumption  
should be transformed into fuel consumption based on the  $\gamma$ .

## 6. Conclusion

In this paper, a benchmark problem for optimal powertrain control of power-  
split HEVs using V2X information is proposed. A simulator of HEV in connect-  
370 ed environment is provided and built in the MATLAB/Simulink platform, which  
consists of V2X information communication and HEV model. The task of the  
benchmark is to design an optimal controller on a fixed road with slope to im-  
prove the performances of the fuel economy; meanwhile several criteria have to  
be fulfilled, such as the travel safety and travel time. A case study is given to  
375 show the characterisers of the powertrain and it is also shown the necessariness  
of optimal powertrain control with consideration of V2X information.

## 7. Acknowledgements

The powertrain model of HEVs in the simulator is provided by Toyota Motor  
Corporation, Japan.

## 380 Appendix A. Delivering

The proposed solutions of the benchmark problem by the challengers should  
be delivered to us in a single package and the file format should be as zip or rar.  
Following actions should be completed in the package:

- The version of MATLAB for controller must be 2018a.
- 385 • The main file of the designed controller must be as a module named Con-  
troller and saved as Controller.slx.
- The necessary pre-computations parameters for controller should be saved  
in the Initial\_parameters.m.
- The supporting files for controller should be named as "FirstAuthor\_XXX".

- 390
- All the documents, including the designed controller, initial parameters and support files for the controller should be in one package and named as "FirstAuthor\_Controller.rar/zip".
  - The success of submission is only certified based on a letter in reply from us.

395 **Appendix B. Important Date**

Table B.8: The time schedule

Event	Time	Remark
Open problem	August 1st, 2020	E-COSM 2021 Website
First submit	May 31st, 2021	Debugging
Final submit	June 30th, 2021	-
Awards	During the conference	-

*Appendix B.1. Open simulator*

The open time of simulator of this benchmark for the challengers are August 1st, 2020. To find the link to download the simulator, please go to the conference website <http://shenlab.jp/ecosm2021/index.html> and the flyer of the Benchmark is in Call for Challenger of the News. For more detail information to the challengers can be found in Benchmark challenge of Programm through this link: <http://shenlab.jp/ecosm2021/program/benchmark-challenge.html>. Even the organizers have tried their best to avoid the mistake, the inevitable updated information of the simulator will also be seen in the page. If there is any question about the simulator, please contact: Dr. Fuguo XU through email: [fuguoXu@sophia.ac.jp](mailto:fuguoXu@sophia.ac.jp).

400

405

*Appendix B.2. Testing period*

During the controller design process for challengers, it is available to test it in our simulation environment since different simulation environment may

410 cause different performance and sometime the controller may not run in our simulation environment. The testing period is set as May 31st, 2021–June 30th, 2021. During this period, please send the designed controller block to *fuguoxu@sophia.ac.jp* and you can test the controller through online remote controlling our public server.

415 *Appendix B.3. Deadline of submit*

The deadline of submitting the final proposed controller block is set as June 30th, 2021 and only a letter in reply from us can certify the successfulness of submission. Please be careful that the submission after this deadline is invalid.

*Appendix B.4. Award*

420 The competition results will be announced at IFAC E-COSM 2021 conference. There is at least one best challenger award for the challenger and other awards will be set dependent on the sponsors. We will try our best to find more sponsors for the benchmark awards.

**References**

- 425 [1] Zhang J, Shen T and Kako J. Short-term optimal energy management of power-split hybrid electric vehicles under velocity tracking control. IEEE Trans. Veh. Technol 2020; 69(1): 182-193.
- [2] Zhang F, Hu X, Langari R and Cao D. Energy management strategies of connected HEVs and PHEVs: recent progress and outlook. Prog. Energy Combust. Sci. 2019; 73: 235-256.
- 430 [3] Lin C C, Peng H, Grizzle J W, et al. Power management strategy for a parallel hybrid electric truck. IEEE Trans. Control Syst. Technol. 2003; 11(6): 839-849 .
- [4] Kim N, Cha S, Peng H. Optimal control of hybrid electric vehicles based on Pontryagins minimum principle. IEEE Trans. Control Syst. Technol. 2010;19(5):1279C87.
- 435

- [5] Larsson V, Johannesson L and Egardt B. Analytic solutions to the dynamic programming subproblem in hybrid vehicle energy management. *IEEE Trans. Veh. Technol.* 2014; 64(4): 1458-1467.
- 440 [6] Sciarretta A, Serrao L, Dewangan P C and et al. A control benchmark on the energy management of a plug-in hybrid electric vehicle. *Control Eng. Pract.* 2014; 29: 287-298.
- [7] Zhang J, Shen T. Real-time fuel economy optimization with nonlinear MPC for PHEVs. *IEEE Trans. Control Syst. Technol.* 2016; 24(6): 2167-2175.
- 445 [8] Sun C, Sun F, He H. Investigating adaptive-ECMS with velocity forecast ability for hybrid electric vehicles. *Appl. Energy* 2017; 185: 1644C1653.
- [9] Zhang F, Xi J, and Langari R. Real-time energy management strategy based on velocity forecasts using V2V and V2I communications. *IEEE Trans. Intell. Transp. Syst.* 2016; 18(2): 416-430.
- 450 [10] Zhang J, Xu F, Zhang Y, et al. ELM-based driver torque demand prediction and realtime optimal energy management strategy for HEVs. *Neural Comput. Appl.* 2019:1C19.
- [11] Zhang B, Zhang J, Xu F and Shen T. Optimal control of power-split hybrid electric powertrains with minimization of energy consumption. *Appl. Energy* 2020; 266: 114873.
- 455 [12] Qi X, Wu G, Hao P and Boriboonsomsin K and Barth M J. Integrated-connected eco-driving system for PHEVs with co-optimization of vehicle dynamics and powertrain operations. *IEEE Trans. Intell. Veh.* 2017; 2(1): 2-13.
- 460 [13] Chen B, Evangelou S A and Lot R. Series hybrid electric vehicle simultaneous energy management and driving speed optimization. *IEEE/ASME Trans. Mechatron.* 2019; 24(6): 2756-2767.

[14] Hu Q, Amini M R, Feng Y, Yang Z, Wang H, Kolmanovsky I and Seeds J B. Engine and aftertreatment co-optimization of connected HEVs via multi-range vehicle speed planning and prediction 2020; SAE Technical Paper 2020-01-0590.

[15] Xu F and Shen T. Look-ahead prediction-based real-time optimal energy management for connected HEVs 2020; IEEE Trans. Veh. Technol., 69(3): 2537-2551.