



UNIVERSITAT  
POLITÈCNICA  
DE VALÈNCIA

UNIVERSITAT POLITÈCNICA DE VALÈNCIA  
DOCTORAL SCHOOL  
**PhD Thesis**

**BIM FOR STEEL BUILDING PROJECTS BIM-  
DFE**

**Author:**

**D. JOSE IGNACIO AVENDAÑO BERNAL**

**Thesis Submitted to the Office of Graduate Studies for the Degree of**

**PHD IN BUILDING ENGINEERING**

**Advisors:**

**DR. ALBERTO DOMINGO CABO**

**DR. CHRISTIAN CORREA**

Valencia, November 2023.

This PhD Thesis is presented in the modality of compendium of published articles, the complete references of the articles that constitute the body of the thesis are shown in the references section.

**Article 1:** Avendaño, José Ignacio, Sisi Zlatanova, Alberto Domingo, Pedro Pérez, and Christian Correa. 2022. "Utilization of BIM in Steel Building Projects: A Systematic Literature Review" *Buildings* 12, no. 6: 713. <https://doi.org/10.3390/buildings12060713>

**Article 2:** Avendaño, José Ignacio, Sisi Zlatanova, Pedro Pérez, Alberto Domingo, and Christian Correa. 2022. "Integration of BIM in Steel Building Projects (BIM-DFE): A Delphi Survey" *Buildings* 12, no. 9: 1439. <https://doi.org/10.3390/buildings12091439>

**Article 3:** Avendaño, José Ignacio, Alberto Domingo, and Sisi Zlatanova. 2023. "Building Information Modeling in Steel Building Projects Following BIM-DFE Methodology: A Case Study" *Buildings* 13, no. 9: 2137. <https://doi.org/10.3390/buildings13092137>

# ACKNOWLEDGMENTS

I extend my sincerest gratitude to Dr. Alberto Domingo Cabo for his unwavering support and guidance. I also express my appreciation to Dr. Sisi Zlatanova and Dr. Christian Correa for their valuable contributions. I am especially grateful to myself for persevering through challenging times and overcoming all the obstacles that came my way. I commend myself for embarking on this journey from humble beginnings, starting in a public school in Talca, Chile, and progressing through an industrial institute, then ventured into the realm of higher education, followed by a professional degree, a master's, and now concluding with a doctorate.

I dedicate this thesis to all those who start from the bottom, driven by a desire for self-improvement. To them, I say, when the night seems darkest, take heart, for it's a sign that dawn is about to break. This thesis reflects that consistency triumphs over fleeting brilliance, and every step counts on the path we each define as happiness.

Dedicated to: Carla, Maite, Mateo. /  
Anita Bernal, Jose Eustaquio  
Avendaño, Anita Avendaño &  
Alejandra.

# ABSTRACT

Steel is an essential material for the construction industry; as a result, its consumption and production per capita have grown considerably, owing to population growth and increasing demands for industrialization in developing countries, among other factors. Steel offers certain advantages over other construction materials, such as low weight, adequate structural behaviors, a high degree of prefabrication, and increased construction speed. However, the use of steel as a construction material has increased the complexity of projects, particularly in terms of information management, because it is imperative to ensure quality and timely information for the different actors involved in the workflow. The inefficient use of information results in fragmentation during construction, to cope with such fragmentation, it is necessary to include building information modeling (BIM) that facilitate collaboration between the different actors involved in the building life cycle. BIM has been associated with improved productivity and cooperation among teams. However, the benefits of using BIM in the steel building process have not been explored comprehensively, even more when BIM does not exhibit continuity throughout the phases of a steel construction project; as a result, its benefits are curtailed. Therefore, there is a need to investigate, develop, and propose BIM integration that generate continuous communication, coordination and management between steel building phases, in order to ensure deliverables that conclude with a building that meets the initially established project requirements.

The present PhD thesis proposes a BIM integration model called BIM for design, fabrication and erection in steel buildings (BIM-DFE) to improve communication, integration, comprehensible procurement processes, and production processes defined by critical stakeholders in the steel industry. These operating benefits can result in benefits for steel-building projects. Although this research is oriented to steel-building projects, the proposed BIM-DFE model can be extrapolated to different materials with similar processes such as concrete, wood or any prefabricated material for the construction industry.

**Keywords:** building information modeling (BIM); steel project life cycle; Delphi; integration model; steel buildings; communication in steel construction projects.

# RESUMEN

El acero es un material esencial para la industria de la construcción; en consecuencia, su consumo y producción per cápita ha aumentado considerablemente, entre otros factores debido al crecimiento de la población y las demandas de industrialización de los países en vías de desarrollo. El acero ofrece ciertas ventajas sobre otros materiales de construcción, por ejemplo, comportamientos estructurales adecuados, alto grado de prefabricación y velocidad de ejecución. En este mismo sentido, el uso del acero como material de construcción ha incrementado la complejidad de los proyectos, particularmente en cuanto a la gestión de la información, ya que se hace imperativo asegurar la información de calidad y oportuna para los diferentes actores que intervienen en el flujo de trabajo. Por otro lado, La fragmentación de las distintas fases que componen un proyecto de construcción en acero da como resultado un uso ineficiente de la información. Para hacer frente a este uso ineficiente, es necesario incluir metodologías como el modelado de información de construcción (BIM) que facilita la colaboración entre los diferentes profesionales y técnicos involucrados en el ciclo de vida de los proyectos de construcción. Generalmente BIM se ha asociado con una mayor productividad y cooperación entre los equipos. Sin embargo, los beneficios de usar BIM en el proceso de construcción en acero no se han explorado exhaustivamente, más aún, cuando BIM es aplicado no existe una homogeneidad de su aplicación a lo largo de las fases de un proyecto de construcción en acero; como resultado, sus beneficios se reducen. Por lo tanto, existe la necesidad de investigar, desarrollar y proponer una integración BIM que

genere una comunicación y coordinación entre las diferentes fases de los proyectos de construcción en acero, de tal manera de asegurar que los entregables cumplan con los requisitos inicialmente establecidos del proyecto.

La presente tesis doctoral propone un modelo de integración de los procesos BIM llamado BIM para el diseño, fabricación y montaje en edificios de acero (BIM-DFE) con el fin de mejorar la comunicación y desempeño en las distintas etapas de este tipo de proyectos. Estos beneficios operativos tienen como finalidad conseguir incrementos importantes de productividad para los proyectos de construcción. Si bien esta investigación está orientada a proyectos de edificación en acero, el modelo BIM-DFE propuesto se podría extrapolar en futuras investigaciones asociadas a diferentes materiales con procesos similares como el hormigón, la madera o cualquier material prefabricado para la industria de la construcción.

**Palabras claves:** building information modeling (BIM); ciclo de vida de los proyectos de acero; Delphi; modelo de integración; construcción en acero; comunicación en proyectos de construcción en acero.

# RESUM

L'acer és un material essencial per a la indústria de la construcció; com a resultat, el seu consum i la producció per càpita han crescut considerablement, a causa del creixement de la població i l'augment de les demandes d'industrialització als països en desenvolupament, entre altres factors.

L'acer ofereix certs avantatges respecte a altres materials de construcció, com ara el baix pes, comportaments estructurals adequats, un alt grau de prefabricació i un augment de la construcció velocitat. No obstant això, l'ús de l'acer com a material de construcció ha augmentat la complexitat de projectes, especialment pel que fa a la gestió de la informació, perquè és imprescindible garantir una informació de qualitat i oportuna als diferents actors implicats en el flux de treball. L'ús ineficient de la informació provoca la fragmentació durant la construcció, per fer front a aquesta fragmentació, cal incloure la modelització de la informació de l'edifici (BIM) que faciliti la col·laboració entre els diferents actors implicats en el cicle de vida de l'edifici. BIM s'ha associat amb una millora de la productivitat i la cooperació entre els equips. No obstant això, els beneficis d'utilitzar BIM en el procés de construcció d'acer no s'han explorat de manera exhaustiva, encara més quan s'utilitza BIM no presenta continuïtat al llarg de les fases d'un projecte de construcció d'acer; com a resultat, els seus beneficis es redueixen. Per tant, cal investigar, desenvolupar i proposar una integració BIM que generi una comunicació, coordinació i gestió contínua entre les fases de



la construcció d'acer, i garantir els lliuraments que concloguin amb un edifici que compleixi els requisits inicialment establerts del projecte.

La present tesi doctoral proposa un model d'integració BIM anomenat BIM per al disseny, fabricació i muntatge en edificis d'acer (BIM-DFE) per millorar la comunicació, la integració, els processos d'adquisició comprensibles i els processos de producció definits per les parts crítiques de la indústria siderúrgica. Aquests beneficis operatius poden donar lloc a beneficis per als projectes de construcció d'acer. Tot i que aquesta recerca està orientada a projectes de construcció d'acer, el model BIM-DFE proposat es pot extrapolar a diferents materials amb processos similars com el formigó, la fusta o qualsevol material prefabricat per a la indústria de la construcció.

**Paraules clau:** modelització de la informació de l'edifici (BIM); cicle de vida del projecte d'acer; Delfos; model d'integració; edificis d'acer; comunicació en projectes de construcció d'acer

# Index

|  |     |
|--|-----|
| Chapter 1 Introduction.....  | 1   |
| 1.1 Background.....  | 1   |
| 1.1.1 Steel and construction industry .....  | 2   |
| 1.1.2 Research problem .....   | 3   |
| 1.1.3 Research Objectives .....  | 3   |
| 1.3 Methodology.....   | 4   |
| 1.4 Dissertation structures.....   | 6   |
| Chapter 2 Utilization of BIM in Steel Building Projects: A Systematic Literature Review .. | 7   |
| 2.1 Introduction .....   | 8   |
| 2.2 Materials and Methods .....  | 12  |
| 2.3 Results .....  | 17  |
| 2.4 Discussion and conclusion .....  | 23  |
| Chapter 3 Integration of BIM in Steel Building Projects (BIM-DFE): A Delphi Survey ....    | 24  |
| 3.1 Introduction .....   | 26  |
| 3.2 Literature Review .....  | 28  |
| 3.3 Research Methodology .....   | 34  |
| 3.4 Results .....  | 40  |
| 3.5 Discussion and conclusion .....  | 51  |
| Chapter 4 BIM in Steel Building Following BIM-DFE Methodology: A Case Study.....           | 52  |
| 4.1 Introduction .....   | 54  |
| 4.2 BIM-DFE.....   | 58  |
| 4.3 Research Methodology .....   | 60  |
| 4.4 Case Study 1 CAD-BIM Application. ....   | 63  |
| 4.5 Case Study 2: BIM-DFE Application. ....  | 76  |
| 4.6 Results .....  | 93  |
| 4.7 Discussion and conclusion .....  | 98  |
| Chapter 5 Discussion of the results .....  | 99  |
| 5.1 Research Question Q1 .....   | 99  |
| 5.2 Research Question Q2 .....   | 108 |

|  |     |
|--|-----|
| 5.3 Research Question Q3 .....   | 123 |
| Chapter 6 Conclusions, contribution, future directions and limitations ..... | 129 |
| 6.1 Research Question Q1. ....   | 129 |
| 6.2 Research Question Q2. ....   | 133 |
| 6.3 Research Question Q3. ....   | 135 |
| References .....   | 137 |
| Appendix .....   | 149 |

## Index of table

|   |     |
|---|-----|
| Table 1. Inclusion and exclusion criteria .....   | 14  |
| Table 2. Keyword combinations for BIM practices used in the SLR process. ....           | 15  |
| Table 3. Articles that resulted from this systemic search.....                          | 16  |
| Table 4. Systemic search results. ....  | 17  |
| Table 5. Number of uses by steel building phases. ....                                  | 21  |
| Table 6. The application of BIM based on phases. ....                                   | 29  |
| Table 7 Inclusion and Exclusion Criteria.....   | 35  |
| Table 8. Panel of experts.....  | 37  |
| Table 9. 1st round of Delphi survey-BIM integration in steel construction projects...43 |     |
| Table 10. Second round of Delphi, BIM integration in steel construction projects.....47 |     |
| Table 11. Characteristics of the case study projects .....                              | 62  |
| Table 12. Team members in planning and design stages.....65                             |     |
| Table 13. Details of subprocesses and personnel involved.....74                         |     |
| Table 14. Planning phase. ....  | 94  |
| Table 15. Design phase. ....  | 94  |
| Table 16. Fabrication phase.. ....  | 94  |
| Table 17. Planning phase. ....  | 96  |
| Table 18. Design phase. ....  | 96  |
| Table 19. Fabrication phase.. ....  | 96  |
| Table 20. BIM uses in application phase and bibliographic resources.....                | 107 |
| Table 21. Deliverables of the BIM integration process map by phases.....                | 122 |
| Table A1. Questions for the first round .....   | 151 |
| Table A2. Questions for the second round.....   | 154 |

## Index of figures

|  |    |
|--|----|
| Figure 1. SLR proces. ....   | 13 |
| Figure 2. Percentage of ranked journals in the bibliographic data. ....  | 18 |
| Figure 3. Evolution of the research literature review. ....  | 19 |
| Figure 4. Number of publications per journal.....  | 19 |
| Figure 5. Cites by continent.....  | 20 |
| Figure 6. BIM utilization is related to the six project life cycle phases: planning, design, fabrication, transport, planning for construction, and erection. .... | 22 |
| Figure 7. Preliminary integration of BIM in steel building projects.....   | 34 |
| Figure 8. Flow chart of the methodology employed in this study . ....  | 34 |
| Figure 9. Evolution of the research literature review. ....  | 40 |
| Figure 10. Number of publications per journal.....   | 41 |
| Figure 11. Importance rating and IRA analysis of the factors (benefits) of the first round of experts.....   | 45 |
| Figure 12 IRA analysis of the factors (benefits) of the second round of experts. ....  | 49 |
| Figure 13. Final consensus of the BIM integration model in steel building projects after the Delphi survey based on expert agreement. ....                         | 50 |
| Figure 14. Outline of the methodology.....   | 61 |
| Figure 15. Details of case study 1.....  | 63 |
| Figure 16. Description of tools used for case study 1.....   | 64 |
| Figure 17. Planning subprocess (case study 1). ....  | 65 |
| Figure 18. Computer-aided design (CAD) estimation drawings (case study 1).....   | 67 |
| Figure 19. Design subprocess (case study 1). ....  | 68 |
| Figure 20. Three-dimensional analytical model sample (case study 1).....   | 68 |
| Figure 21. Two-dimensional preliminary plan (case study 1). ....   | 69 |
| Figure 22. Modified drawing after client approval (case study 1).....  | 70 |
| Figure 23. CAD connection design sample (case study 1) ....  | 70 |
| Figure 24. Sample 2D CAD drawing (case study 1) ....   | 71 |
| Figure 25. Fabrication subprocess (case study 1). ....   | 72 |
| Figure 26. Material preparation using (CNC) plasma sample (case study 1). ....   | 73 |
| Figure 27. Preassembly.....  | 75 |
| Figure 28. Flowchart of the CAD-BIM methodology used in case study 1. ....   | 75 |
| Figure 29. Isometric case study 2 .....  | 76 |

|   |     |
|---|-----|
| Figure 30. Description of tools used for case study 2.....                        | 77  |
| Figure 31. Planning processes for case study 2 .....                              | 78  |
| Figure 32. BIM estimation model.....  | 79  |
| Figure 33. Design process for case study 2.....                                   | 82  |
| Figure 34. IFC configuration from the Tekla structure.....                        | 83  |
| Figure 35. Sample analysis of model in SAP2000 .....                              | 84  |
| Figure 36. SAP2000 export to Tekla structure by Steel-Detailing Neutral File..... | 85  |
| Figure 37. Optimized Tekla model. ....  | 85  |
| Figure 38. Steel connection import and export to and from RISA 3D. ....           | 86  |
| Figure 39. Fabrication phase for case study 2.....                                | 88  |
| Figure 40. Steel-detailing samples (case study 2).....                            | 89  |
| Figure 41. Nesting process and Tekla STRUMIS information transfer .....           | 91  |
| Figure 42. Summary of hours by phases.....  | 97  |
| Figure 43. Summary of fabrication hours/ton.....                                  | 98  |
| Figure 44. Fish processing plant by the VVL engineering company.. ....            | 110 |
| Figure 45. BIM estimation model sample.....                                       | 111 |
| Figure 46. CAD connection design sample (case study 1) .....                      | 112 |
| Figure 47. Design process of BIM-DFE.....   | 113 |
| Figure 48. ETABS Model LOD 200 sample .....                                       | 114 |
| Figure 49. Tekla Model Study sample.....  | 115 |
| Figure 50. Steel BIM LOD 400—Study sample.....                                    | 115 |
| Figure 51. Idea Connection software sample.....                                   | 116 |
| Figure 52. Fabrication process by BIM-DFE .....                                   | 117 |
| Figure 53. Steel BIM Fabrication Study sample. ....                               | 118 |
| Figure 54. Transportation by BIM-DFE. ....  | 119 |
| Figure 55. Steel BIM truck loading sample.....                                    | 119 |
| Figure 56. BIM-DFE Erection .....   | 120 |
| Figure 57. BIM-DFE-Erection model.....  | 121 |
| Figure A1. Journal Citation Reports.....  | 159 |
| Figure A2. Article 1 front page.....  | 161 |
| Figure A3. Article 2 front page.....  | 162 |
| Figure A4. Article 3 front page.....  | 163 |

---



# Chapter 1

## Introduction

### 1.1 Background

The construction industry, which includes design and construction activities, is a fundamental part of the global economy and accounts for approximately six percent of the total gross domestic product, which is equivalent to approximately 10 trillion USD annually (Stojanovska-Georgievska et al., 2022; Barbosa et al., 2017). Recently, the conventional construction industry encountered a technological revolution that mitigates the classic errors of this industry, such as time delays, cost, and construction quality. An important factor in this technological revolution is building information modeling (BIM), which was developed as a solution to mitigate the errors of traditional construction (Basta et al., 2020). BIM is a series of activities that can improve deliverables in the design and construction process (Miettinen & Paavola, 2014; Succar, 2009; M. Wang et al., 2020) and is intended to optimize the information transfer processes, which is vital for fluid design and construction. Examples of how BIM can benefit the stakeholders in this industry include the following:

Principal/owner: Control of project expectations from an economic and visual perspective.

Engineers/Designers: Designers can improve the long-term relationships with various stakeholders owing to a better understanding of the different sub-processes for the materialization of construction projects.

Builder/executing engineer: Permit to contribute



their knowledge during the design process or update the model during different stages of construction, thus improving pre-execution and on-site planning and gaining a better understanding of the design and building (Diakite & Zlatanova, 2020; Avendaño et al., 2022b; Wang et al., 2020).

### **1.1.1 Steel and construction industry**

Steel is an essential material for the construction industry; as a result, its consumption and production per capita have grown considerably, owing to population growth and increasing demands for industrialization in developing countries, among other factors. Steel offers certain advantages over other construction materials, such as low weight, adequate structural behaviors, a high degree of prefabrication, and increased construction speed (Liu et al., 2021; Navaratnam et al., 2019) Steel construction can be divided into two categories: (1) “concrete building,” which is realized using concrete and steel bars (reinforced concrete); and (2) “steel building,” where steel is considered the primary construction material (Hadiwattege & Kandemulla., 2018). Steel construction involves a wide variety of projects, such as industrial, housing, and non-housing projects, which have lower costs and greater social values than those associated with reinforced concrete (Y. F. Liu et al., 2021; Navaratnam et al., 2019).

A steel building project comprises factory-made components or units transported and assembled in the shop or on-site (IA et al., 2016). The work phases involved are (1) planning, (2) design, (3) fabrication, (4) transport, (5) construction planning, and (6) erection of the structure (IA et al., 2016; K. Kim et al., 2009). The efficient completion of these steps maximizes the benefits of working with steel (Thomas et al., 2017). However, the use of steel as a construction material has increased the complexity of projects, particularly in terms of

information management, therefore it is imperative to ensure quality and timely information for the different actors involved in the workflow. Thus, redoing processes can be avoided, and, consequently, the associated costs and construction time can be reduced (Avendaño et al., 2022b).

### **1.1.2 Research problem**

The use of BIM does not exhibit continuity throughout the phases of a steel construction project; therefore, its benefits are curtailed. In other cases, they are developed in the late phases or within a phase. Therefore, there is a need to investigate, develop, and propose a BIM process map that generate continuous communication, coordination, management between phases, and ensure deliverables that conclude with a building that meets the initially established project requirements.

### **1.1.3 Research Objectives**

Considering the gaps described in the previous section, the present PhD thesis aims to answer the following questions and objectives:

Q1. What are the use cases of BIM in steel building projects?

- Objective 1.1: Identify BIM uses in steel building projects validated by the scientific community.
- Objective 1.2: Identify the BIM uses that generate continuity in the transfer of information through the different phases of the steel building project.
- Objective 1.3: Establish new lines of BIM research for steel building projects.

Q2. Is it possible to merge the scientific knowledge and the industry experience, in order to create an original BIM integration process map to improve the management of steel building projects?

- Objective 2.1: Design a BIM process map based on the BIM uses found in the scientific literature.
- Objective 2.2: Systematically validate the BIM process map with experts in the steel building industry.

Q3. How does the implementation of the BIM-based process map for steel construction projects, derived from the preceding objectives 2.1 and 2.2, quantitatively influence outcomes when applied within an authentic case study?

- Objective 3.1: Implement the BIM-based process map for steel construction projects in a real-world case.
- Objective 3.2: Compare the BIM-based process map for steel construction projects with traditional CAD-BIM methodologies used in the industry.

The present PhD thesis proposes a BIM integration process map to improve communication, integration, comprehensible procurement processes, in the design, fabrication and erection for steel-building projects (BIM-DFE).

### **1.3 Methodology**

To comply with the BIM-DFE proposal in this PhD thesis, the following activities were established:

Firstly, as theoretical phase a systematic literature review (SLR) was designed to locate, analyze, and synthesize the evidence available in literature to answer the aforementioned

research question (Q1). Systematic reviews follow well-defined and transparent steps and always require the following: precision of the question, identification of the available scientific documentation, and summary of the findings. Therefore, an SLR was used to achieve the research objectives.

Secondly, considering the results obtained from the literature review, a preliminary BIM-DFE proposal was considered as the first approach in integrating BIM in steel building projects.

Thirdly, as validation phase 32 participants were invited to complete a two-round Delphi questionnaire to validate the BIM-DFE proposal. The participants were classified according to their knowledge level (skilled or expert). The Delphi methodology was used to obtain a consensus from this panel of experts with geographically dispersed (Q2). A statistical analysis was performed from the first round of the Delphi questionnaire, the results generated new adjustment guidelines for the questionnaire in the second round. The second round was conducted with the same experts and total number of participants in the validation phase. As a result, an integrated BIM process map called BIM-DFE consensus was reached.

Finally, this thesis seeks to showcase BIM-DFE, within a real-world context. This constitutes the inaugural application of this methodology to an actual case. In pursuit of this objective, two steel building projects featuring analogous design typologies were meticulously selected. The primary project harnessed computer-aided design and conventional BIM techniques throughout the planning, design, and fabrication phases. In contrast, the BIM-DFE methodology was implemented within the same phases for the secondary project. As a result, a quantitative comparison of project outcomes was undertaken. Furthermore, this study attested to the pragmatic viability of the BIM-DFE methodology in real-world scenarios

## 1.4 Dissertation structures

Taking into consideration the overall research method displayed in the previous section, the general structure of the dissertation is:

- Chapter 1 provides an overview of the thesis highlighting the research problem, knowledge gap, research questions, and research goals, as well as the research methodology conducted.
- Chapter 2 presents a literature review to bridge the information gap pertaining to the utilization of building information modeling (BIM) in steel building projects. It was conducted to synthesize the available BIM uses. In this chapter it is also possible to visualize the gaps that exist around this topic and future lines of research.
- Chapter 3 presents the BIM integration model for steel building projects. It was developed in the following three phases: (i) theoretical phase, (ii) validation phase, and (iii) statistical analysis for the theoretical phase.
- Chapter 4 the utilization of BIM-DFE methodology in real-world scenarios for steel building projects is discussed. The chapter explores two comparable projects, evaluating traditional CAD-BIM approaches against BIM-DFE integration.
- Chapter 5 presents a discussion of the results obtained in the previous chapters.
- Chapter 6 Summarizes the main conclusions, and future research directions drawn from this PhD thesis.
- References.
- Appendix.

# Chapter 2

## Utilization of BIM in Steel Building Projects: A Systematic Literature Review

Authors: José Ignacio Avendaño, Sisi Zlatanova, Alberto Domingo, Pedro Pérez and Christian Correa

Status: Manuscript published

Journal: Buildings 2022

DOI: <https://doi.org/10.3390/buildings12060713>

JCR IF (2021): 3.324

| JCR Category                       | Ranking | Quartile |
|------------------------------------|---------|----------|
| Construction & Building Technology | 28/68   | Q2       |
| Engineering, Civil                 | 58/138  | Q2       |

Presentation: Post-Print (Author version)

**Abstract:** This research aims to bridge the information gap pertaining to the utilization of building information modeling (BIM) in steel building projects. Therefore, a systematic literature review (SLR) was conducted to synthesize the available uses. This research involved three phases planning, execution, and reporting according to the PRISMA guide, which includes the main aspects of identification, screening, and eligibility. As a result of the SLR, it is evident how and where BIM facilitates steel building projects, which were grouped into three different categories according to their main BIM topics. One of the uses that stands out as a common denominator across the different processes is “early integration.” Early integration allows for optimization of the design based on existing resources, directly affecting the cost and time of steel building projects in a positive manner.

**Keywords:** building information modeling (BIM); steel project life cycle; project management; communication in steel construction projects.

## **2.1 Introduction**

Steel is an essential material for the construction industry; as a result, its consumption and production per capita have grown considerably, owing to population growth and increasing demands for industrialization in developing countries, among other factors (Gutowski et al., 2017). Steel offers certain advantages over other construction materials, such as low weight, adequate structural behaviors, a high degree of prefabrication, and increased construction speed (Y. F. Liu et al., 2021; Navaratnam et al., 2019). Steel construction can be divided into two categories: (1) “concrete building,” which is realized using concrete and steel bars (reinforced concrete); and (2) “steel building,” where steel is considered the primary construction material (Hadiwattege & Kandemulla., 2018). Steel construction involves a

wide variety of projects, such as industrial, housing, and non-housing projects, which have lower costs and greater social values than those associated with reinforced concrete (Y. F. Liu et al., 2021; Navaratnam et al., 2019). A steel building project comprises factory-made components or units transported and assembled in the shop or on-site (IA et al., 2016). The work phases involved are (1) planning, (2) design, (3) fabrication, (4) transport, (5) construction planning, and (6) erection of the structure (IA et al., 2016; K. Kim et al., 2009). The efficient completion of these steps maximizes the benefits of working with steel (Thomas et al., 2017.). However, the use of steel as a construction material has increased the complexity of projects, particularly in terms of information management, because it is imperative to ensure quality and timely information for the different actors involved in the workflow. Thus, redoing processes can be avoided, and, consequently, the associated costs and construction time can be reduced. The inefficient use of information results in fragmentation during construction (Mellado et al., 2020). To cope with such fragmentation, it is necessary to include building information technologies that facilitate collaboration between the different actors involved in the building life cycle (Bryde et al., 2013).

Building information modeling (BIM) refers to a set of processes that improve the deliverables, relationships, and roles of stakeholders in the construction industry (Kaewunruen et al., 2020; Succar, 2009). These deliverables are framed under the concept of the level of development, which is a reference tool that is aimed at improving the quality of communication between the users of building information models and provides guidelines pertaining to the characteristics and details of the elements in the 3D models. (Moretti et al., 2020 ; Olanrewaju et al., 2022). BIM reduces costs and improves management efficiency (Ghaleb et al., 2022; Stojanovska-Georgievska et al., 2022), prioritizing the needs of the



project, among other things, above each specialty or process. Some of the benefits of using this technology for each actor are as follows:

Principal/Owner: Enables efficient information exchange, streamlines project communications, and generates options that allow for effective changes to achieve the project objective, without sacrificing cost control, budget management, and schedule.

Engineers/Designers: Enables designers to improve their long-term relationship with different stakeholders, owing to better understanding of the different sub-processes for the materialization of the construction project.

Builder/Executing Engineer: Enables the contribution of their knowledge during the design process, or updating of the model during different stages of construction, thereby improving pre-execution and on-site planning, and affording a better understanding of design and building (Diakite & Zlatanova, 2020; M. Wang et al., 2021).

Over recent years, other technologies have been complemented by BIM, such as virtual reality (VR), augmented reality (AR), digital twins, and the Internet of Things (IoT) (Schiavi et al., 2022).

Augmented Reality: This computer technology can provide a highly immersive construction experience to different stakeholders, or be used to monitor the construction process (García-Pereira et al., 2020; Moretti et al., 2020).

Virtual Reality: Contrary to AR, VR is mainly used for planning and simulation in the different phases of construction projects. This technology can be used to reveal limitations

from a contractor's perspective because it is considered more akin to an animation, rather than an actual construction representation (M. Wang et al., 2020).

Digital Twins: This concept aims to bridge the actual and digital worlds by employing sensor technology for monitoring and analysis, in order to adapt to actual construction or digital plans. Similar to BIM, it can be used across different project stages (Deng et al., 2021).

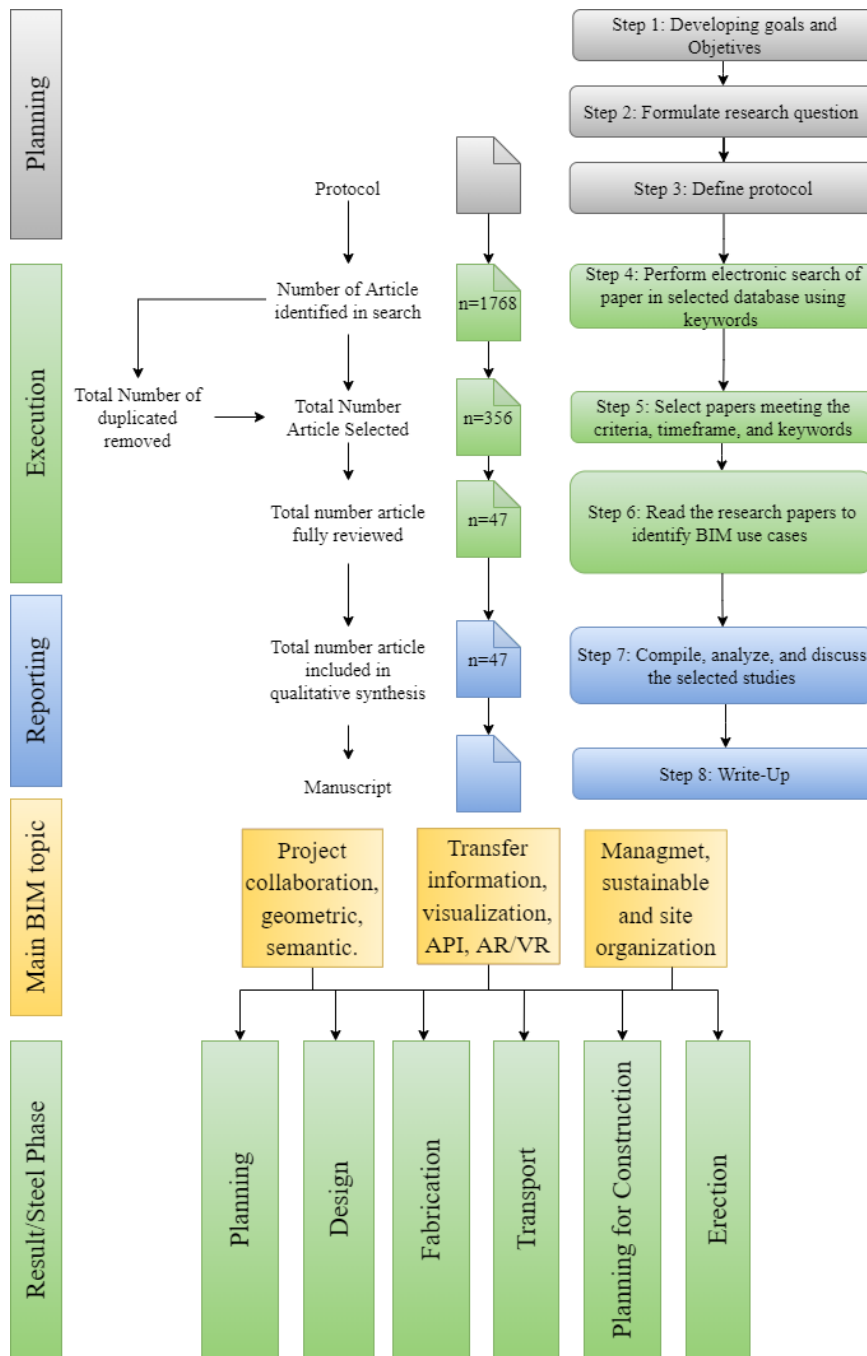
Internet of Things: The IoT facilitates interconnect physical entities (such as humans, equipment, devices, and workstations) and collects all data from different processes (H. M. Chen & Huang, 2013; L. K. Chen et al., 2021b; Moretti et al., 2020).

Combining BIM, AR/VR, digital twins, and IoT with actual data from a construction project enables stakeholders to obtain information regarding the predicted state of construction. However, many challenges exist in transferring data between the different software packages to allow for smooth and seamless utilization (García-Pereira et al., 2020; Nguyen et al., 2021).

BIM has been associated with improved productivity and cooperation among teams and different phases; accordingly, BIM has been employed in many applications, such as urban management and navigation (L. Liu et al., 2021). However, the benefits of using BIM in the steel building process have not been explored comprehensively (S. Chen et al., 2020). Hence, the objective of this study was to identify the uses of BIM and its benefits pertaining to steel building processes. To this end, a systematic literature review (SLR) related to BIM in steel buildings was conducted.

## **2.2 Materials and Methods**

Traditional literature reviews lack a transparent and reproducible process that enables others to determine the accuracy of the results (Tricco et al., 2011). By contrast, systematic reviews of the literature are more informative and scientific when conducted rigorously and are, therefore, well justified (Paul et al., 2021; Hijazi et al., 2021). Thus, in this work, a systematic review was designed to locate, analyze, and synthesize the evidence available in literature to accomplish the objective of this research (Valdés et al., 2018). Systematic reviews follow well-defined and transparent steps and always require the following: precision of the question, identification of the available scientific documentation, and summary of the findings (Boland et al., 2017). Therefore, an SLR was used to achieve the research objectives, according to the approach suggested by Tanfield (Tranfield et al., n.d.). The structure of this research entails three phases: (1) planning, (2) execution, and (3) reporting (Daspit, 2017); this is illustrated in Figure 1.



**Figure 1.** SLR process. Modified from (S. W. Kim & Brown, 2021).

Protocol establishes searching and evaluating processes regarding information to answer questions and to achieve the objective (Vera-Puerto et al., 2020), that is, to identify BIM practices in the steel building project. Subsequently, research questions were formulated

based on the provisions of the population, the phenomenon of interest, and context (PIC) elements for qualitative reviews. PIC elements can aid in defining the question, and the inclusion, and exclusion, criteria used to select studies for systematic review (Stern et al., 2014). Therefore, the following question was formulated.

Research Question: ¿What are the use cases of BIM in steel building projects?

To address the issue of article quality, it was decided to primarily include content from peer-reviewed journals, such as the Web of Science (WOS) and Scopus. Between 2012 and 2022, see Table 1, the search strings used were: (a) “Steel” (b) “Building Information Modeling”, (c) “Detailing”, (d) “Construction”, (e) “Manufacturing”, (f) “Prefabrication,” (g) “Impact business”, (h) “Innovation industry”, (i) “Structures”, and (j) “Projects performance.” see Table 2.

**Table 1.** Inclusion and exclusion criteria. Modified from (Boland et al., 2017)

| <b>Criteria</b> | <b>Inclusion</b>  | <b>Exclusion</b>  |
|-----------------|---|---|
| 1               | Articles that discuss BIM in the steel building project | Articles that do not discuss BIM in the steel building projects |
| 2               | Articles that are in WOS and/or Scopus                  | Articles that are not in WOS and/or Scopus                      |
| 3               | Articles that were published in 2012–2022               | Article published before 2012                                   |

**Table 2.** Keyword combinations for BIM practices used in the SLR process.

| Combinations          | Results from database  |        |
|-----------------------|--|--------|
|                       | WoS  | Scopus |
| C1: K1 AND K2 AND K3  | 118  | 19     |
| C2: K1 AND K2 AND K4  | 267  | 327    |
| C3: K1 AND K2 AND K5  | 94   | 64     |
| C4: K1 AND K2 AND K6  | 12   | 9      |
| C5: K1 AND K2 AND K7  | 3  | 9      |
| C6: K1 AND K2 AND K8  | 22   | 6      |
| C7: K1 AND K2 AND K9  | 420  | 319    |
| C8: K1 AND K2 AND K10 | 35   | 44     |
| TITLE-ABS-KEY         | C1: Steel AND Building Information Modeling AND Detailing            |        |
|                       | C2: Steel AND Building Information Modeling AND Construction         |        |
|                       | C3: Steel AND Building Information Modeling AND Manufacturing        |        |
|                       | C4: Steel AND Building Information Modeling AND Prefabrication       |        |
|                       | C5: Steel AND Building Information Modeling AND Impact business      |        |
|                       | C6: Steel AND Building Information Modeling AND Innovation industry  |        |
|                       | C7: Steel AND Building Information Modeling AND Structures           |        |
|                       | C8: Steel AND Building Information Modeling AND Projects performance |        |

The execution process began with a documentation search of the selected databases. Duplicate articles (present in different databases) were only considered once to avoid counting a previously found article twice. The selected articles were positioned as relevant or irrelevant, according to the magnitude of their titles and abstracts to respond to the research questions (Valdés et al., 2018; Vera-Puerto et al., 2020). Categorization was performed independently by each author (L. K. Chen et al., 2021). Articles were evaluated using an article quality checklist. This quality checklist form was adapted from PRISMA 2020 and contained 12 items. The most relevant ones are the locality of the research, steel building project description, BIM use name,

BIM use description, and performance indicators (Page et al., 2021). Table 3 summarizes the SLR that resulted in a total of 47 articles.

**Table 3.** Articles that resulted from this systemic search.

| Screening Step                   | Number of Articles in Sample |
|----------------------------------|------------------------------|
| Original sample                  | 1768                         |
| Duplicates removed               | 643                          |
| After cut-off point              | 356                          |
| Unrelated articles removed       | 309                          |
| Articles that could be retrieved | 47                           |
| Final sample                     | 47                           |

Once the relevant articles were identified, the “Quality assessment” activity was conducted. In this activity, the authors conducted a comprehensive analysis of the relevant articles to select those related to BIM utilization in steel building projects. As in the previous process, a crosscheck of the documentation found was performed (Krippendorff, 2018). Subsequently, the “Data extraction” activity commenced, which consisted of obtaining information directly related to the question of this work. The systematic classification and evaluation of the evidence in the articles were conducted using the methodological principles of the grounded data theory (TFD); in other words, through constant comparisons, the evidence is collected, coded, and analyzed to generate concepts and groups to discover the relationships between these articles and, thus, obtain decisive evidence pertaining to the questions posed and construct explanations (Pellicer et al., 2012). To minimize errors in the analysis and interpretation of the extracted information, the authors held periodic online meetings to resolve inconsistencies in the interpretation of the results.

In the reporting stage, the results of the research were recorded. Then, we mapped the main elements of the literature, that is, tabulated the results to visualize how many studies met the

inclusion criteria. The next step was to combine the BIM use cases into one of the three groups: 1. Project collaboration: Geometric Semantic; 2. Transfer information, visualization API, AR, and VR; 3. Management, sustainability, and site organization. The information/uses analyzed, due to the complexity, were grouped into the following project phases (IA et al., 2016; K. Kim et al., 2009): (1) planning, (2) design, (3) fabrication, (4) transport, (5) planning for construction, and (6) erection; this helps explain its application and its relationship with the other phases of the steel building project

### 2.3 Results

Table 4 shows the year of publication, journal, CI, quartile, and impact factor of the journals that published this bibliographical search. The Journal of Conservation and Recycling has the highest impact factor, followed by the Journal of Cleaner Production and the Automation in Construction journal.

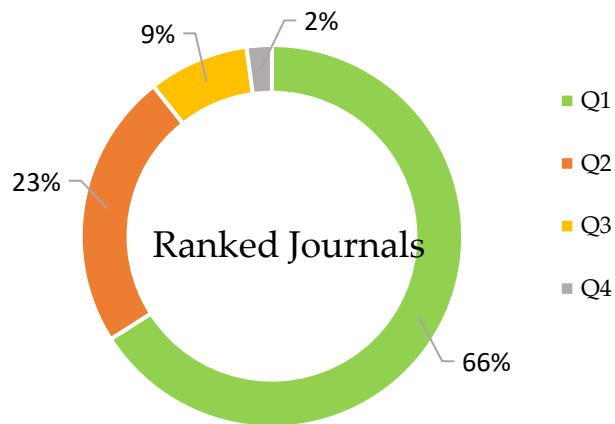
**Table 4.** Systemic search results.

| Source  | Quartile | Impact Factor |
|---|----------|---------------|
| Advanced Engineering Informatics                | Q1       | 6.41          |
| Advances in Civil Engineering                   | Q3       | 1.8           |
| Applied Mechanics and Materials                 | Q2       | 3.15          |
| Applied Sciences                                | Q2       | 2.736         |
| Architectural Engineering and Design Management | Q2       | 2.19          |
| Automation in Construction                      | Q1       | 9.16          |
| Bautechnik                                      | Q3       | 0.35          |
| Conservation and Recycling                      | Q1       | 9.93          |
| ISPRS International Journal of Geo-Information  | Q1       | 2.899         |
| International Journal of Steel Structures       | Q2       | 1.33          |



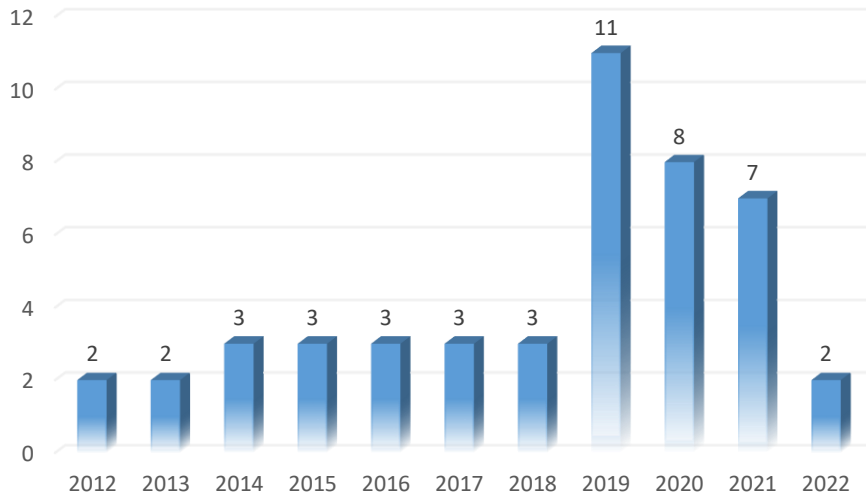
|  |    |       |
|--|----|-------|
| Journal of Building Engineering  | Q1 | 5.7   |
| Journal of Cleaner Production  | Q1 | 9.297 |
| Journal of Facilities Management   | Q2 | 2.19  |
| Key Engineering Materials  | Q4 | 0.45  |
| KSCE Journal of Civil Engineering  | Q2 | 1.97  |
| Stahlbau   | Q3 | 0.23  |
| Sustainability (Switzerland)   | Q1 | 3.48  |
| Transportation Research Record: Journal of the Transportation Research Board | Q2 | 1.81  |

Figure 2 shows the percentage of ranked journals in the bibliographic data; 66% of the data are from the journals in the first quartile, 23% are from those in the second quartile, 9% are from those in the third quartile, and 2% are from those in the fourth quartile.



**Figure 2.** Percentage of ranked journals in the bibliographic data.

Figure 3 depicts the historical literature review, which indicates that the largest number of publications related to this research was presented between 2019 and 2020.



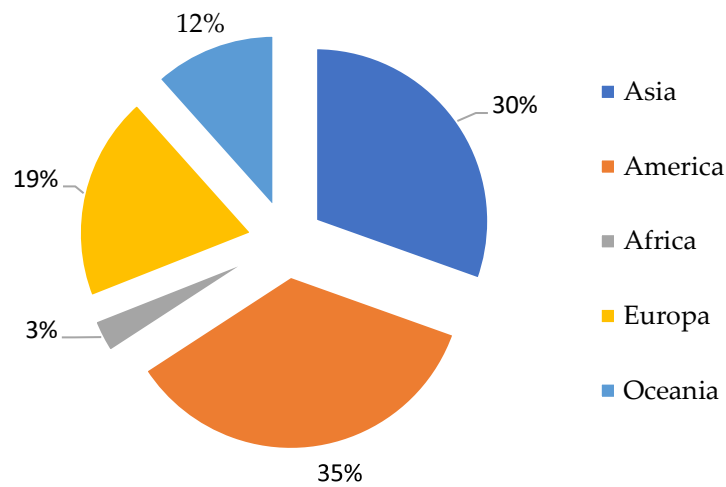
**Figure 3.** Evolution of the research literature review.

Figure 4 shows the relationship between the journals with the highest number of publications on this topic. The Automation in Construction journal stands out with 21 articles.



**Figure 4.** Number of publications per journal.

Figure 5 shows the percent of citations found for the articles included in this review, divided by continent. It indicates that most articles were cited from Asia and North America, followed by Europe, Oceania, and Africa. Authors with more than one publication include Al-Hussein, M., Ahmad, R., followed by Yoo, M., Martinez, P., Wang, Q., Cheng, J., Yu, J., and Park, J.



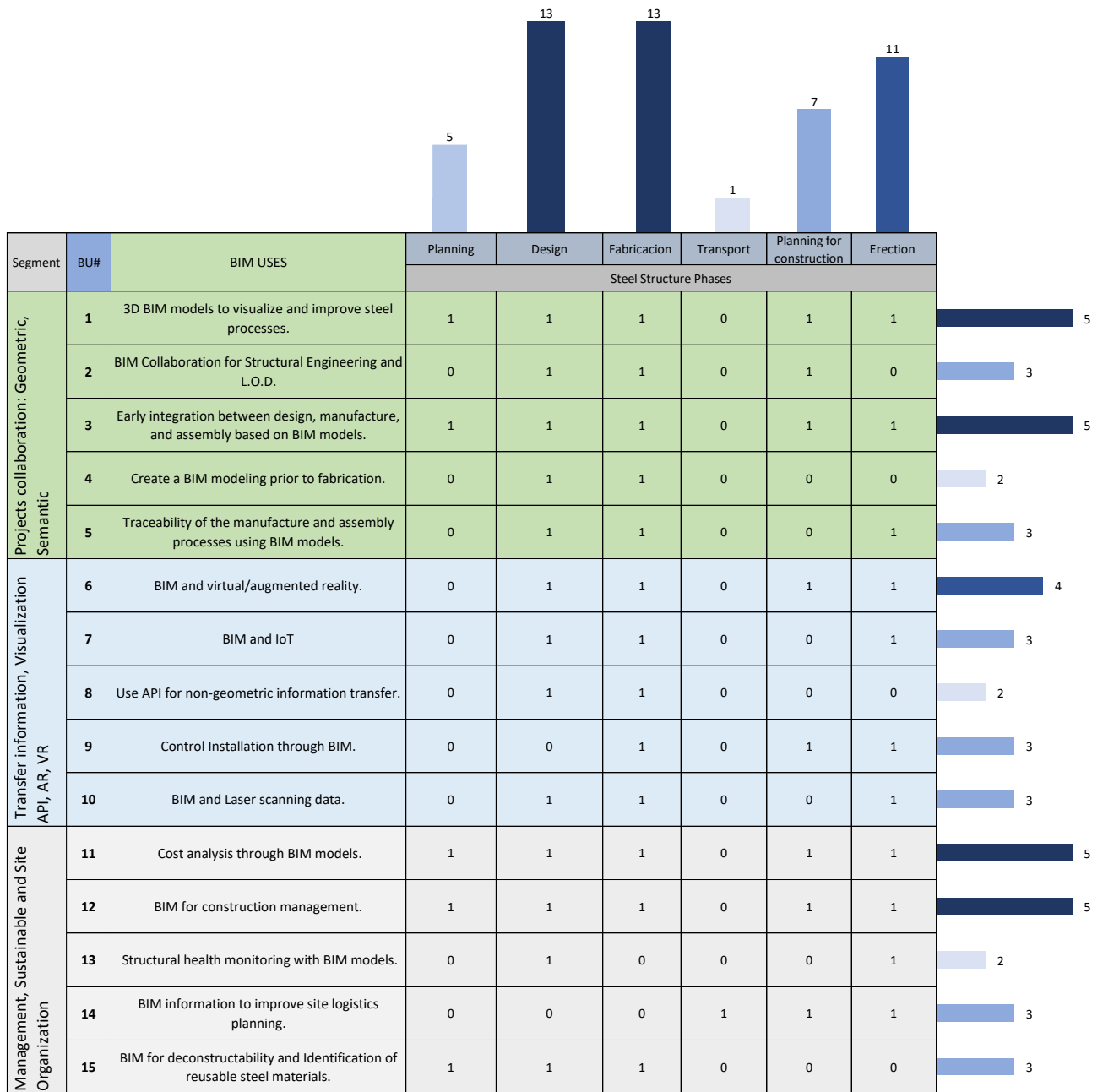
**Figure 5.** Cites by continent.

Table 5 shows the BIM uses involved in the different stages of the steel buildings project life cycle. These uses were compiled for each phase, as indicated in Figure 6.

**Table 5.** Number of uses by steel building phases.

| <b>Number of BIM Uses by Phases</b> |               |                    |                  |                                  |                 |
|-------------------------------------|---------------|--------------------|------------------|----------------------------------|-----------------|
| <b>Planning</b>                     | <b>Design</b> | <b>Fabrication</b> | <b>Transport</b> | <b>Planning for Construction</b> | <b>Erection</b> |
| 5                                   | 13            | 13                 | 1                | 7                                | 11              |

Figure 6 summarizes the BIM uses related to the six steel building phases involved: planning, design, fabrication, transport, planning for construction, and erection (IA et al., 2016; K. Kim et al., 2009). The sidebars indicate the specific process in which the uses are executed, whereas the upper bars indicate the number of uses involved in each process. In addition, these were grouped under three different categories according to their main BIM topics.



**Figure 6.** BIM utilization is related to the six project life cycle phases: planning, design, fabrication, transport, planning for construction, and erection.

## **2.4 Discussion and conclusion**

Considering that the investigations presented in this PhD thesis are complementary to each other, the discussions and conclusions have been grouped in chapter 5 and 6 respectively.

## Chapter 3

# Integration of BIM in Steel Building Projects (BIM-DFE): A Delphi Survey

Authors: José Ignacio Avendaño, Sisi Zlatanova, Alberto Domingo, Pedro Pérez and Christian Correa

Status: Manuscript published

Journal: Buildings 2022

DOI: <https://doi.org/10.3390/buildings12091439>

JCR IF (2021): 3.324

| JCR Category                       | Ranking | Quartile |
|------------------------------------|---------|----------|
| Construction & Building Technology | 28/68   | Q2       |
| Engineering, Civil                 | 58/138  | Q2       |

Presentation: Post-Print (Author version)

**Abstract:** This study aims to design an integrated BIM process map for steel building projects (BIM-DFE). It was developed in the following three phases: (i) theoretical phase, (ii) validation phase, and (iii) statistical analysis for the theoretical phase. A literature review was conducted to study the applications of BIM in steel building projects and to develop an integrated BIM process map for the construction lifecycle of steel buildings. Subsequently, in the validation phase, 32 participants were invited to complete a two-round Delphi questionnaire to validate the BIM-DFE proposal. The participants were classified according to their knowledge level (skilled or expert). Based on the literature review, a process map that integrates BIM in different phases of a steel building project was created. In the first round of the Delphi questionnaire for the validation phase, the various groups studied (skilled vs. expert) were in moderate agreement with the BIM-DFE proposal; however, after the second round, this agreement became better. Therefore, this study contributes to the current body of knowledge by providing a BIM integration model to improve the management of steel building projects as defined by critical stakeholders in the steel industry. In addition, a real-time case is presented to elucidate a part of the research contribution.

**Keywords:** building information modeling (BIM); steel project life cycle; delphi; integration model; steel buildings



### 3.1 Introduction

The construction industry, which includes engineering and construction activities, is a fundamental part of the global economy and accounts for approximately six percent of the total gross domestic product, which is equivalent to approximately 10 trillion USD annually (Barbosa et al., 2017; Stojanovska-Georgievska et al., 2022). Recently, the conventional construction industry encountered a technological revolution that mitigates the classic errors of this industry, such as time delays, cost, and construction quality. An important factor in this technological revolution is building information modeling (BIM), which was developed as a solution to mitigate the errors of traditional construction (Basta et al., 2020). BIM is a series of activities that can improve deliverables in the design and construction process (Miettinen & Paavola, 2014; Succar, 2009; M. Wang et al., 2020) and is intended to optimize the information transfer processes, which is vital for fluid design and construction. Examples of how BIM can benefit the stakeholders in this industry include the following:

Principal/owner: Control of project expectations from an economic and visual perspective.

Engineers/Designers: Designers can improve the long-term relationships with various stakeholders owing to a better understanding of the different threads for the materialization of construction projects.

Builder/executing engineer: Permit to contribute their knowledge during the design process or update the model during different stages of construction, thus improving pre-execution

and on-site planning and gaining a better understanding of the design and building (Diakite & Zlatanova, 2020; Avendaño et al., 2022; Wang et al., 2020).

BIM can offer different options for construction management as it provides effective design and documentation as well as supports and improves the critical factors of a project (Hyarat et al., 2022).

However, there could be issues with regard to the generated data, such as data loss, data inconsistency, errors, and liability for erroneous or incomplete data in 3D BIM models. Adopting a collaborative approach to BIM in certain projects further complicates these issues (Alreshidi et al., 2017). BIM management has been attributed to the productivity and cooperation between teams.

Considering the growth of the global population and increase in industrialized materials, steel has become an essential component for construction (Gutowski et al., 2017); however, its use has increased the complexity of projects, particularly in information management, because it is imperative to present quality information in a timely manner to the different actors involved in the workflow (Mellado et al., 2020). A steel-building project comprises factory-made components or units that are transported and assembled in a shop or on-site and involves the following phases: (1) planning, (2) design, (3) fabrication, (4) transport, and (5) erection of the structure. An efficient completion of these steps maximizes the benefits of working with steel (Avendaño et al., 2022a; Thomas & Ellis, 2017). However, the benefits of using BIM for steel construction projects have not been accurately explored (S. Chen et al., 2020).

The use of BIM does not exhibit continuity throughout the phases of a steel construction project; therefore, its benefits are curtailed. In other cases, they are developed in the late phases or within a phase. Therefore, there is a need to investigate, develop, and propose BIM usages that generate continuous communication, coordination, management between phases, and ensure deliverables that conclude with a building that meets the initially established project requirements (Avendaño et al., 2022b).

This integration is achieved by incorporating BIM in the process map throughout the all phases of steel buildings. It is then validated by surveying a forum of experts using the Delphi methodology. The aim of this study is to propose a model to improve communication, integration, comprehensible procurement processes, and production processes in this specific area of steel construction. These operating benefits can result in macroeconomic benefits for steel-building projects.

### **3.2 Literature Review**

A literature review was conducted to analyze the current evidence in the academic community regarding the application of BIM for steel construction and its integration between the phasing between. Fifteen uses of BIM were identified; the observations of each are presented in Table 6. This shows that in steel construction projects, BIM is usually used as a visualization engine that replaces 2D drawings with 3D virtual models to generate a greater comprehension of the objects materialized during steel construction processes (S. Chen et al., 2020; Xie et al., 2017; M. Yoo & Ham, 2020).

**Table 6.** The application of BIM based on phases. Ref. Table 1 (Avendaño et al., 2022b)

| <b>BIM (B#)</b> | <b>BIM Utilization</b>   | <b>Observation from Literature Review</b>   |
|-----------------|--|---|
| 1               | 3D BIM models to visualize and improve steel processes.  | <i>The 3D model is used as a compression engine that replaces 2D drawings and is used in all phases except the transport phase.</i>   |
| 2               | BIM Collaboration for Structural Engineering and LOD.  | <i>Defining the levels of detail (LOD) in BIM models saves time in the design process and reduces the information requirement for stakeholders.</i>   |
| 3               | Early integration between design, manufacturing, and assembly based on BIM models.             | <i>Integration between design, manufacturing, and assembly based on BIM models allows incorporating the physical resources of the fabricator, transport, and erector, which results in the reduction in total project costs.</i>  |
| 4               | Creating a BIM prior to fabrication.   | <i>The creation of BIM models, including in the manufacturing stages, empowers manufacturers to automate their fabrication processes by connecting computer numerical control (CNC) with the BIM model. It also reduces the time for steel detailing and the fabrication processes.</i> |
| 5               | Quality control and traceability of the manufacturing and assembly processes using BIM models. | <i>BIM models in fabrication stages provide the status of each manufactured item, such as painting, welding, assembly, and dispatch status. This imparts traceability to the steel elements.</i>  |
| 6               | BIM and virtual/augmented reality  | <i>The augmented reality application improves decision-making because it allows simulating various scenarios for selection of the one most advantageous for the project.</i>  |
| 7               | BIM and IoT  | <i>Controlling the erection of steel structures through BIM and Internet of things (IoT) allows for a transparent relationship between the contractor and subcontractor and an exact follow-up of the assembled elements.</i>   |
| 8               | Use of API for non-geometric information transfer.   | <i>Application programming interface (API) allows transferring non-geometric information, such as supplier codes and technical specifications, which increases technical communication between stakeholders.</i>  |
| 9               | Controlled installation through BIM.   | <i>Controlling the erection of steel structures through BIM allows for an exact follow-up of the assembled elements.</i>  |
| 10              | BIM and laser scanning data.   | <i>The use of laser scanners and BIM models in erection stages allows for the precise erection in a field. It is also generally used to create a BIM model based on existing conditions through point clouds.</i>   |
| 11              | Cost analysis through BIM models.  | <i>4D and 5D BIM models allow an independent evaluation of each specialty, allowing a better understanding of the scope of work for each bidder.</i>  |
| 12              | BIM for construction management.   | <i>BIM models allow controlling the amount of material used in a project and managing the man-hours assigned in planning to detect deviations in time and materials from an economic perspective at an early stage and make decisions accordingly.</i>                                  |
| 13              | Structural health monitoring with BIM models.  | <i>The use of microchips along with BIM models allows for the identification of structural failures caused by transportation or poor stockpiling of material prior to assembly.</i>   |
| 14              | BIM information to improve site logistics planning.  | <i>The use of BIM models oriented to planning for construction generates a delivery action map of the elements to be assembled in the field; thus, stockpiling and transfer times are optimized.</i>  |
| 15              | BIM for deconstructability and identification of reusable steel materials                      | <i>BIM is used to identify reusable materials in the deconstruction stage to reduce construction waste and cost of project materials.</i>   |

There is limited use of BIM in the early stages of a project, particularly in the planning phase. This prevents the optimization of the benefits obtained by using these models at this stage, including understanding stakeholders who are not part of the construction industry, such as the owners or investors of a project (Avendaño et al., 2022).

Studies have demonstrated various forms of BIM usage in the design stage, where early integration is highlighted as a methodology that enables a better understanding of the manufacturer and erector resources to make them available in the design stages (Barg et al., 2018; Erfurth, 2019; Laefer & Truong-Hong, 2017; Z. S. Liu et al., 2014).

Regarding the manufacturing phase, BIM is presented as a communication amplifier that transforms 3D graphic information from the design to the numerical control machinery (CNC) used to materialize steel structures, such as cutting plasmas and robotic welding machines (An et al., 2020; S. Chen et al., 2020; Costin et al., 2021).

In contrast to the previous phases, the transportation phase provides the least amount of evidence of BIM usage in steel construction (Avendaño et al., 2022b), highlighting only the incorporation of sensors in steel structures, which allows for the identification of the location of trucks through GPS sensors to improve planning and logistics in the field (H. M. Chen & Huang, 2013).

Regarding the planning phases for construction and erection, the use of BIM is highlighted as a repository of costs to identify the pricing of machinery and labor to be used in construction (Navaratnam et al., 2022; Barg et al., 2018; Oti & Tizani, 2015; Shahtaheri et al., 2017), and to control the structural state of the parts arriving from the factory before and after

assembly (AbouHamad & Abu-Hamd, 2019; Akanmu & Okoukoni, 2018; H. M. Chen & Huang, 2013; L. K. Chen et al., 2021; K. Kim et al., 2020; Liao et al., 2012; Mischo et al., 2019; Navaratnam et al., 2022; Nekouvaght Tak et al., 2020; Yang et al., 2020; Yoo et al., 2019; Yu et al., 2021; Zhang & Bai, 2015; Tummalapudi et al., 2021). The literature highlights the use of BIM to identify materials with reusable potential in deconstruction stages to minimize the costs of future projects and reduce the carbon footprint in the construction industry (Asgari Siahboomy et al., 2021; Basta et al., 2020; Ding et al., 2019).

Although the aforementioned literature review shows the benefits of using BIM in the different phases of steel construction projects, they are either unilaterally considered in the phases or the integration is evident only between two phases (design and fabrication); a collaborative BIM process map that integrates all phases of the project supported by the BIM methodology remains absent (Avendaño et al., 2022b).

The BIM usage process map is considered as the first approach in integrating BIM in steel building projects (BIM-DFE) (Figure 7). BIM-DFE consists of five phases and groups of processes. The phases are as follows:

*Planning phase:* The planning phase begins with the need for construction determined by the owner. The type of project is subsequently defined; it can be commercial, residential, or industrial. The following proposed sub-process includes the selection of a design engineer who will fulfill the role of the project manager and accompany the entire steel construction process from design to assembly (Barg et al., 2018; Erfurth, 2019; Laefer & Truong-Hong, 2017; Tian et al., 2021). Once the project manager and designer have been selected, a BIM estimation model is created, allowing early identification of the number of tons to be

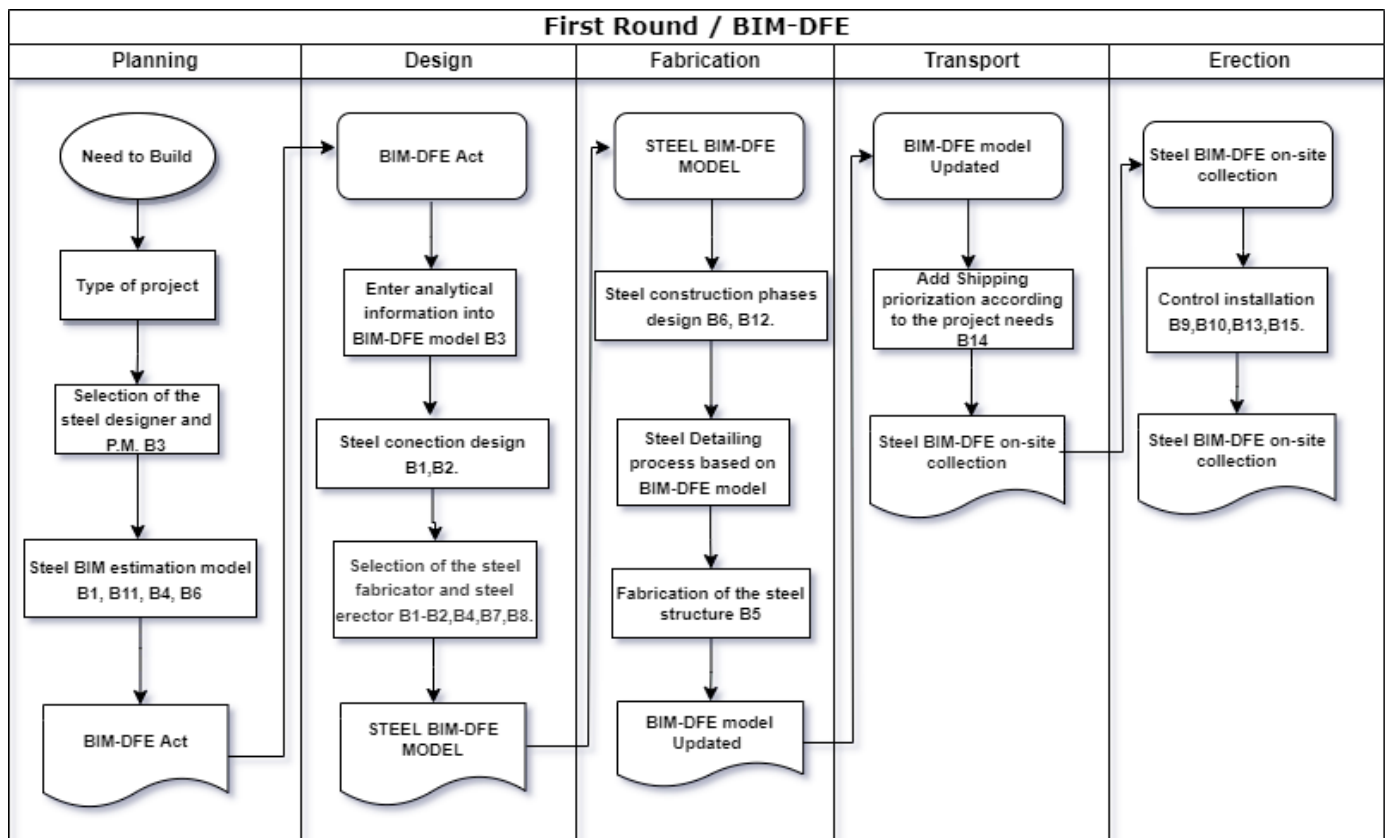
processed. Finally, this stage is completed with a BIM-DFE act that frames the BIM deliverables of each specialty in the subsequent phases.

*Design Phase:* The proposed design phase begins with the BIM-DFE act from the previous phase, and the next sub-process is the incorporation of the finite element analysis of the structure; the BIM estimation model from the previous phase (AbouHamad & Abu-Hamd, 2019; Akanbi et al., 2018; Akanmu & Okoukoni, 2018; Asgari Siahboomy et al., 2021; Bartenbach et al., 2019; Bortolini et al., 2019; H. M. Chen & Huang, 2013; L. K. Chen et al., 2021; Costin et al., 2021; Ding et al., 2018; Ding et al., 2019; Galic et al., 2015; Jeong et al., 2016; K. Kim et al., 2020; Liao et al., 2012; Z. S. Liu et al., 2014; Martinez et al., 2019; Nekouvaght Tak et al., 2020; Ness et al., 2015; Scianna et al., 2022; Soh et al., 2022; Tang et al., 2019; Tavares et al., 2019; Tummalapudi et al., 2021; W. C. Wang et al., 2014; Wei et al., 2014; Yang et al., 2020; M. Yoo et al., 2019; W. S. Yoo et al., 2012; Yu et al., 2021; Zhang & Bai, 2015; Zhu et al., 2021) is considered as the starting point. The connection calculation thread is subsequently introduced (Barg et al., 2018). Once the design of the structural elements and the connections is complete, it is passed to the next sub-process, which is the selection of the manufacturer and assembler (Oti & Tizani, 2015). The design process ends with a BIM-DFE model with a defined structural design.

*Fabrication phase:* This phase begins with the BIM-DFE model from the previous phase. The following thread is the determination of the phases and sequences of the project (Asgari Siahboomy et al., 2021); the structural details are developed to create the parts and pieces necessary for manufacturing according to the aforementioned phases and sequences. Subsequently, the manufacturing stage begins and is monitored using a BIM model (Malik et al., 2019). This phase finally ends with a BIM-DFE model that contains an update regarding the manufacturing status.

*Transport Phase:* This phase begins with the BIM-DFE model updated with the manufacturing information from the previous phase. The prioritization of shipments is then added according to the needs of the project. This phase ends with a BIM-DFE model that contains updated information regarding the shipments from the fabricator to the field.

*Erection Phase:* This phase begins with the BIM-DFE on-site collection model from the previous phase, and the assembly of the steel elements is controlled using a laser scanner in coordination with other specialties of the project (Mischo et al., 2019; Yang et al., 2020). Finally, this phase ends with a BIM-DE model that contains updated information on the project assembly status to be shared with the remaining stakeholders.

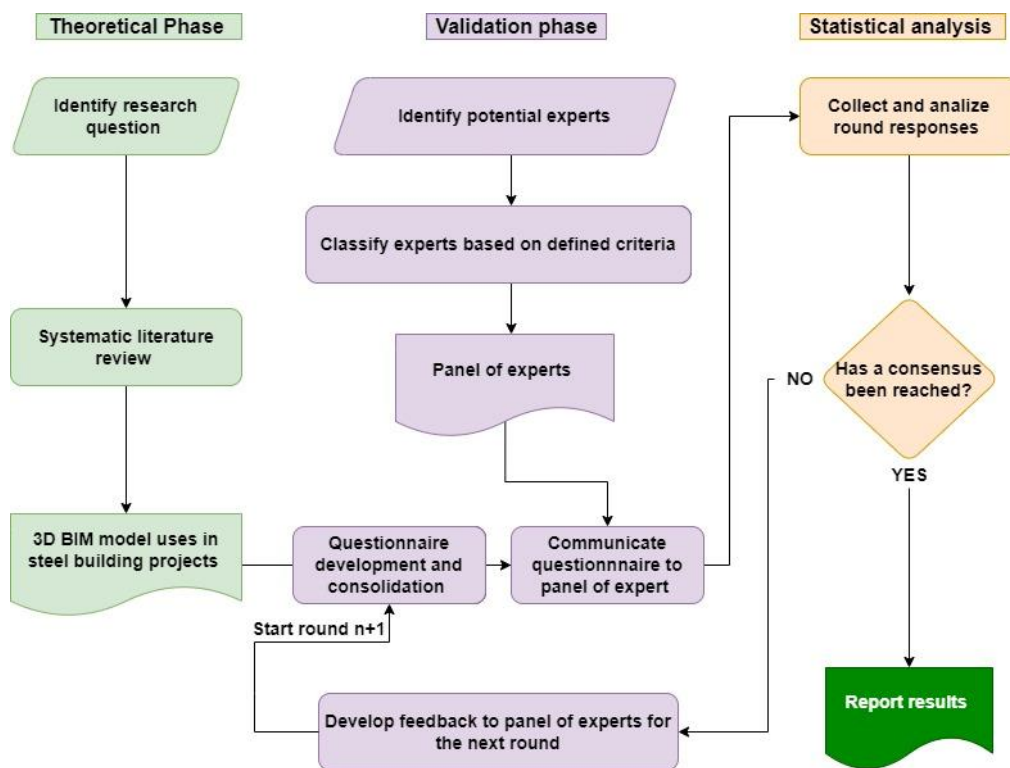




**Figure 7.** Preliminary integration of BIM in steel building projects (B# indicates the BIM uses from Table 6).

### 3.3 Research Methodology

The methodology proposed in this study consists of the following three phases theoretical, validation and statistical analysis. (Figure 8).



**Figure 8.** Flow chart of the methodology employed in this study. Modified from (Vera-Puerto et al., 2020).

#### *Theoretical Phase*

The theoretical phase involved a literature review to determine BIM uses and processes in steel building projects; in addition, the literature review helped identify the lack of BIM

integration in steel building projects and in developing a preliminary BIM-DFE proposal (Figure 7).

The literature review included content from peer-reviewed journals, such as the Web of Science (WOS) and Scopus (Table 7). The following search strings were used for the relative articles published between 2012 and 2022: “steel”, “building information modeling”, “detailing”, “construction”, “manufacturing”, “prefabrication”, “steel process construction”, “steel BIM process construction”, “structures” and “projects performance”.

**Table 7.** Inclusion and Exclusion Criteria (Avendaño et al., 2022).

| Criteria | Inclusion   | Exclusion  |
|----------|---|--|
| 1        | Articles discussing BIM in a steel building project | Articles not discussing BIM in steel building projects |
| 2        | Articles in WOS and/or Scopus                       | Articles not in WOS and/or Scopus                      |
| 3        | Articles published between 2012–2022                | Articles published prior to 2012                       |

#### *Validation Phase: Modified Delphi Methodology*

The Delphi method consists of a systematic and interactive search to retrieve the greatest agreement from a group of experts regarding a specific topic; an underlying definition of the method is provided as follows: “Delphi may be characterized as a method for structuring a group communication process so that the it is effective in allowing a group of individuals, as an entirety, to manage a complex problem”. This methodology provides an accurate approach for the search of new information regarding complex topics (Evans & Farrell, 2021).

The Delphi technique is a structured method used to obtain a consensus from a panel of experts (Ginigaddara et al., 2022; Olawumi & Chan, 2019); moreover, it presents the advantage of conducting reviews with geographically dispersed experts from various industrial sectors

(Biggs et al., 2013; Cerezo-Narváez et al., 2021; LeBreton & Senter, 2008; Olatunji et al., 2017; Olawumi & Chan, 2019; Saka & Chan, 2020; Soh et al., 2020; Tummalapudi et al., 2021). This method was used for identifying the integration of BIM in steel-building projects, which was careful not to guide any response through the questions that were presented to the panel of experts; a consensus of the opinions was then calibrated based on the responses from the experts in the rounds of questions (Cerezo-Narváez et al., 2021). At least two rounds of questions and answers are imperative for correctly using the Delphi method. In this manner, a valid consensus on the hypothesis or questions posed can be ensured. At least seven members of a panel of experts are recommended to answer the questions for this method to be successful (Cerezo-Narváez et al., 2021; Olawumi & Chan, 2019; Saka & Chan, 2020).

Following the literature review, a combination of qualitative and quantitative methods was performed with a panel of experts. This is often referred to as the ‘modified Delphi method’ (MDM). First, a pilot survey was conducted with four participants (industry experts) to review and validate the factors that helped further specify the questionnaire (Olawumi & Chan, 2019). All the changes proposed by these four experts were included in the first Delphi rounds. Subsequently, 32 experts were invited to answer the Delphi questionnaire. The selected experts should have the knowledge and competence in the relative subject matter, as well as a significant understanding of the problem. Accordingly, the panel members required to be part of the initial sample were steel building experts. The initial requirements for this included having relevant experience and a significant understanding of BIM and steel building projects; Table 8 demonstrates the qualifications of the panel of experts. The requirements were as follows:

- Expertise in building project management, construction management,

- Designing technical projects, or directing projects.
- A minimum of fifteen years of experience.
- Participation in at least ten projects worth more than \$500,000.
- Transfer experience with at least five collaboration contracts in different phases of steel building projects.

The level of agreement in the questionnaire for each steel building phase was based on the 5-point Likert scale: 1 = disagree, 2 = indifferent, 3 = slightly agree, 4 = agree, and 5 = strongly agree. The number of iterations required to obtain the agreement of the experts was determined according to the answers received. Finally, the questionnaire collected personal information from the experts. The authors guaranteed anonymity of the participants (Cerezo-Narváez et al., 2021; Ginigaddara et al., 2022; Hyarat et al., 2022; Olawumi & Chan, 2019; Vera-Puerto et al., 2020).

**Table 8.** Panel of experts.

| Country   | Specialization | Profession                | Development Area | Average Years of Experience |
|-----------|----------------|---------------------------|------------------|-----------------------------|
| Argentina | Planning       | Civil engineer            |                  | 22.5                        |
|           | Design         | Building engineer         | Professional     |                             |
|           | Fabrication    | Assembler                 | Academic         |                             |
|           | Erector        |                           |                  |                             |
| Chile     |                | Civil engineer            |                  | 18.3                        |
|           | Planning       | Mechanical civil engineer |                  |                             |
|           | Design         | Assembler                 | Professional     |                             |
|           | Fabrication    | Maker                     | Academic         |                             |
|           | Erection       | Industrial engineer       |                  |                             |
|           |                | Building engineer         |                  |                             |

|               |             |                     |              |      |
|---------------|-------------|---------------------|--------------|------|
|               | Planning    |                     |              |      |
| Spain         | Design      | Civil engineer      | Professional | 21.4 |
|               | Fabrication | Computer engineer   | Academic     |      |
|               | Erection    |                     |              |      |
|               | Planning    | Civil engineer      |              |      |
| United States | Design      | Mechanical engineer | Professional | 25.6 |
|               | Fabrication | Assembler           | Academic     |      |
|               | Erection    |                     |              |      |

### *Expert Panel Composition and Classification*

A panel of experts was selected based on their knowledge and experience of steel construction projects, including those currently working in universities, research centers, steel manufacturing, steel design engineering, and steel structure assembly. The panel of experts was classified based on years of experience, as follows: (a) one to 15 years (five experts); (b) greater than 16 years (27 experts) (Table 3).

### *Statistical Analysis*

The agreement level of the experts was determined using statistical tools for the questionnaire techniques, which are presented in the same order as they were used:

- a. A Cronbach's reliability test (a) was conducted to validate the reliability of the questionnaire based on the responses. The values varied from zero to one. Values greater than 0.7 were considered acceptable for further analysis (Olatunji et al., 2017).
- b. The following characterizations were made to define a level of significance based on each question:

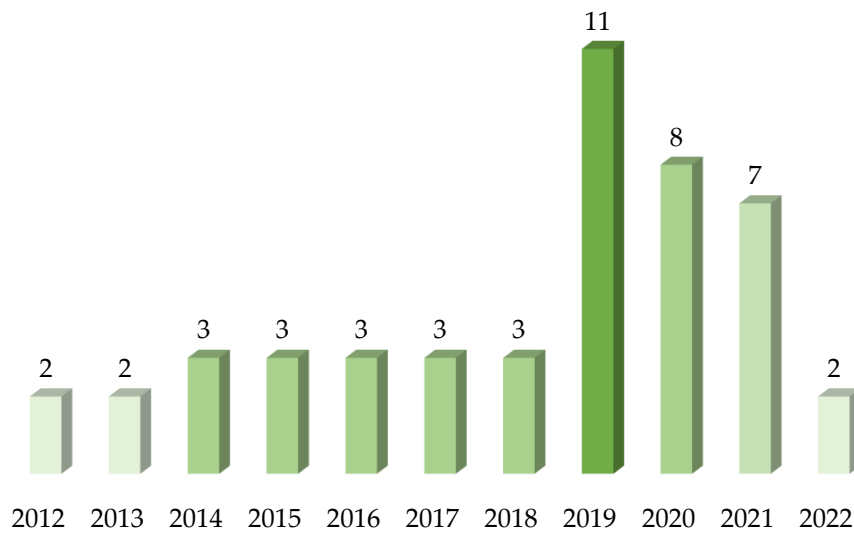
- i. “Not important” ( $M < 1.5$ ),
  - ii. “Somewhat important” ( $1.51 < M < 2.5$ ),
  - iii. “Important” ( $2.51 < M < 3.5$ ),
  - iv. “Very important” ( $3.51 < M < 4.5$ ), and
  - v. “Extremely important” ( $M > 4.51$ ).
  
- c. Kendall’s coefficient of concordance ( $W$ ) was used to measure the level of agreement within the panel of experts and ascertain the consistency of agreement across the two rounds of the Delphi survey. The value of  $W$  ranged from zero (perfect disagreement) to one (perfect agreement). Additionally, the chi-square value indicates the robustness of the consensus with the associated p-value (significance level, 0.05).
  
- d. Interrater agreement statistics (IRA;  $a_{wg}$ ) were used to analyze and validate the expert agreements among the respondent groups. IRA analysis was performed using the code deduced in (LeBreton & Senter, 2008) as follows:
  - i.  $0.0 < a_{wg} < 0.30$  “lack of agreement”,
  - ii.  $0.31 < a_{wg} < 0.50$  “weak agreement”,
  - iii.  $0.51 < a_{wg} < 0.70$  “moderate agreement”,
  - iv.  $0.71 < a_{wg} < 0.90$  “strong agreement” and
  - v.  $0.91 < a_{wg} < 1.00$  “very strong agreement”.

All statistical analyses were performed using the SPSS software version Statistics.

### 3.4 Results

#### *Theoretical Phase*

Figure 9 illustrates that the largest number of publications relative to this study were presented between 2019 and 2021.



**Figure 9.** Evolution of the research literature review.

Figure 10 presents the journals with the highest number of publications regarding this topic.

The journal of *Automation in Construction* is noteworthy considering 21 articles.



**Figure 10.** Number of publications per journal.

*Validation Phase: Delphi Methodology: First Round*

The Delphi survey was answered by 32 experts, of which (a) five participants had between one and 15 years of experience, (b) and 27 participants had greater than 16 years of experience. To assess the consistency of the survey, the responses were segmented as indicated above. Therefore, the relevant statistical analyses were performed using Cronbach's alpha test and Kendall's coefficient.



Tables 9 and 10 present the statistical analyses performed for the answers provided by the expert panel, which demonstrates a variety of data such as the average, standard deviation, number of experts, value that defines the normality of the sample, as well as Cronbach's alpha value and Kendal's coefficient that endorse the reliability and concordance between specialists, respectively. Kendall's W coefficient was greater than zero for all processes, indicating an agreement among those evaluated. Table 9 presents the coding of the questions from Appendix Table A1. The mean and standard deviation for the panel of experts classified into the following: one to fifteen years of experience, greater than sixteen years of experience, number of respondents, and the statistical data. As a result of the first analysis, the Cronbach's alpha coefficient values that were obtained ranged between 0.795 to 0.55, as the experts were segmented as indicated. The Cronbach's alpha value of all the experts was 0.773, which is higher than 0.7, making it acceptable for further analysis (Biggs et al., 2013).

**Table 9.** 1st round of Delphi survey-BIM integration in steel construction projects.

**EXPERTS ROUND 1**

| Code | All the experts in the area |                    | One to fifteen years of experience |                    | More than sixteen years of experience |                    |
|------|-----------------------------|--------------------|------------------------------------|--------------------|---------------------------------------|--------------------|
|      | Mean                        | Standard Deviation | Mean                               | Standard Deviation | Mean                                  | Standard Deviation |
| Q1   | 4.03                        | 0.822              | 4.00                               | 0.707              | 4.04                                  | 0.854              |
| Q2   | 2.59                        | 1.214              | 2.20                               | 0.837              | 2.67                                  | 1.271              |
| Q3   | 4.13                        | 0.660              | 4.00                               | 0.707              | 4.15                                  | 0.662              |
| Q4   | 4.31                        | 0.738              | 4.40                               | 0.894              | 4.30                                  | 0.724              |
| Q5   | 4.53                        | 0.567              | 4.60                               | 0.894              | 4.52                                  | 0.509              |
| Q6   | 4.47                        | 0.671              | 4.60                               | 0.548              | 4.44                                  | 0.698              |
| Q7   | 4.09                        | 0.777              | 3.80                               | 0.837              | 4.15                                  | 0.770              |
| Q8   | 3.75                        | 0.762              | 3.80                               | 0.837              | 3.74                                  | 0.764              |
| Q9   | 4.16                        | 0.515              | 4.00                               | 0.707              | 4.19                                  | 0.483              |
| Q10  | 3.84                        | 0.808              | 3.80                               | 0.837              | 3.85                                  | 0.818              |
| Q11  | 4.25                        | 0.672              | 4.40                               | 0.894              | 4.22                                  | 0.641              |
| Q12  | 4.28                        | 0.729              | 4.60                               | 0.548              | 4.22                                  | 0.751              |
| Q13  | 4.50                        | 0.622              | 4.60                               | 0.548              | 4.48                                  | 0.643              |
| Q14  | 4.03                        | 0.822              | 4.00                               | 0.707              | 4.04                                  | 0.854              |
| Q15  | 4.06                        | 0.716              | 4.00                               | 1.000              | 4.07                                  | 0.675              |
| Q16  | 4.09                        | 0.777              | 4.20                               | 0.837              | 4.07                                  | 0.781              |
| Q17  | 4.03                        | 0.822              | 4.20                               | 0.837              | 4.00                                  | 0.832              |
| Q18  | 4.22                        | 0.792              | 3.80                               | 0.837              | 4.30                                  | 0.775              |
| Q19  | 4.28                        | 0.772              | 4.00                               | 1.225              | 4.33                                  | 0.679              |
| Q20  | 4.34                        | 0.787              | 4.60                               | 0.548              | 4.30                                  | 0.823              |
| Q21  | 4.25                        | 0.762              | 4.60                               | 0.548              | 4.19                                  | 0.786              |
| Q22  | 4.16                        | 0.628              | 4.20                               | 0.447              | 4.15                                  | 0.662              |
| Q23  | 3.94                        | 0.716              | 4.00                               | 0.707              | 3.93                                  | 0.730              |
| Q24  | 4.19                        | 0.780              | 4.60                               | 0.548              | 4.11                                  | 0.801              |
| Q25  | 4.19                        | 0.859              | 4.00                               | 1.225              | 4.22                                  | 0.801              |

|     |      |       |      |       |      |       |
|-----|------|-------|------|-------|------|-------|
| Q26 | 4.16 | 0.677 | 4.60 | 0.548 | 4.07 | 0.675 |
| Q27 | 4.09 | 0.689 | 4.40 | 0.548 | 4.04 | 0.706 |
| Q28 | 4.03 | 0.782 | 4.00 | 0.707 | 4.04 | 0.808 |

---

STATISTICAL DATA

---

|   |       |       |       |
|---|-------|-------|-------|
| Cronbach's $\alpha$<br>reliability value          | 0.773 | 0.55  | 0.795 |
| Number of<br>respondents                          | 32    | 5     | 27    |
| Kendall's<br>coefficient of<br>concordance<br>(W) | 0.133 | 0.258 | 0.127 |

---

Figure 11 presents the results of the IRA analysis and the significance level of the questions for the assessment of the strength of the expert consensus regarding these questions, generating a basis for the second round and defining the status of the first questionnaire. The ranking of the consensus of all the experts was analyzed considering their years of experience. In the first round, “Q2” was the lowest-performing question.

| EXPERTS ROUND 1 |                             |                    |                     |                                    |                    |                     |                                       |                    |                     |
|-----------------|-----------------------------|--------------------|---------------------|------------------------------------|--------------------|---------------------|---------------------------------------|--------------------|---------------------|
| Code            | All the experts in the area |                    |                     | One to fifteen years of experience |                    |                     | More than sixteen years of experience |                    |                     |
|                 | avg SCORE                   | Agreement level    | Significance grade  | avg SCORE                          | Agreement level    | Significance grade  | avg SCORE                             | Agreement level    | Significance grade  |
| Q1              | 0.56                        | moderate agreement | very important      | 0.68                               | moderate agreement | very important      | 0.52                                  | moderate agreement | very important      |
| Q2              | 0.26                        | lack of agreement  | important           | 0.60                               | moderate agreement | somewhat important  | 0.20                                  | lack of agreement  | important           |
| Q3              | 0.69                        | moderate agreement | very important      | 0.68                               | moderate agreement | very important      | 0.68                                  | moderate agreement | very important      |
| Q4              | 0.54                        | moderate agreement | very important      | 0.24                               | lack of agreement  | very important      | 0.56                                  | moderate agreement | very important      |
| Q5              | 0.63                        | moderate agreement | extremely important | -                                  | not applicable     | not applicable      | 0.70                                  | moderate agreement | extremely important |
| Q6              | 0.53                        | moderate agreement | very important      | 0.60                               | moderate agreement | extremely important | 0.51                                  | weak agreement     | very important      |
| Q7              | 0.58                        | moderate agreement | very important      | 0.60                               | moderate agreement | very important      | 0.57                                  | moderate agreement | very important      |
| Q8              | 0.67                        | moderate agreement | very important      | 0.60                               | moderate agreement | very important      | 0.67                                  | moderate agreement | very important      |
| Q9              | 0.81                        | strong agreement   | very important      | 0.68                               | moderate agreement | very important      | 0.83                                  | strong agreement   | very important      |
| Q10             | 0.62                        | moderate agreement | very important      | 0.60                               | moderate agreement | very important      | 0.61                                  | moderate agreement | very important      |
| Q11             | 0.64                        | moderate agreement | very important      | 0.24                               | lack of agreement  | very important      | 0.68                                  | moderate agreement | very important      |
| Q12             | 0.57                        | moderate agreement | very important      | 0.60                               | moderate agreement | extremely important | 0.57                                  | moderate agreement | very important      |
| Q13             | 0.57                        | moderate agreement | very important      | 0.60                               | moderate agreement | extremely important | 0.56                                  | moderate agreement | very important      |
| Q14             | 0.56                        | moderate agreement | very important      | 0.68                               | moderate agreement | very important      | 0.52                                  | moderate agreement | very important      |
| Q15             | 0.66                        | moderate agreement | very important      | 0.36                               | weak agreement     | very important      | 0.69                                  | moderate agreement | very important      |
| Q16             | 0.58                        | moderate agreement | very important      | 0.47                               | weak agreement     | very important      | 0.59                                  | moderate agreement | very important      |
| Q17             | 0.56                        | moderate agreement | very important      | 0.47                               | weak agreement     | very important      | 0.55                                  | moderate agreement | very important      |
| Q18             | 0.52                        | moderate agreement | very important      | 0.60                               | moderate agreement | very important      | 0.50                                  | weak agreement     | very important      |
| Q19             | 0.51                        | moderate agreement | very important      | 0.04                               | lack of agreement  | very important      | 0.60                                  | moderate agreement | very important      |
| Q20             | 0.46                        | weak agreement     | very important      | 0.60                               | moderate agreement | extremely important | 0.44                                  | weak agreement     | very important      |
| Q21             | 0.54                        | moderate agreement | very important      | 0.60                               | moderate agreement | extremely important | 0.54                                  | moderate agreement | very important      |
| Q22             | 0.71                        | strong agreement   | very important      | 0.85                               | strong agreement   | very important      | 0.68                                  | moderate agreement | very important      |
| Q23             | 0.68                        | moderate agreement | very important      | 0.68                               | moderate agreement | very important      | 0.67                                  | moderate agreement | very important      |
| Q24             | 0.55                        | moderate agreement | very important      | 0.60                               | moderate agreement | extremely important | 0.55                                  | moderate agreement | very important      |
| Q25             | 0.45                        | weak agreement     | very important      | 0.04                               | lack of agreement  | very important      | 0.51                                  | weak agreement     | very important      |
| Q26             | 0.67                        | moderate agreement | very important      | 0.60                               | moderate agreement | extremely important | 0.69                                  | moderate agreement | very important      |
| Q27             | 0.67                        | moderate agreement | very important      | 0.72                               | strong agreement   | very important      | 0.67                                  | moderate agreement | very important      |
| Q28             | 0.60                        | moderate agreement | very important      | 0.68                               | moderate agreement | very important      | 0.57                                  | moderate agreement | very important      |

**Figure 11.** Importance rating and IRA analysis of the factors (benefits) of the first round of experts.

Considering the IRA score and significance level analysis, the results for the other questions provided results ranging from a weak to a strong agreement for the IRA, and from important to extremely important for the significance level with respect to the mean.

*Validation Phase: Delphi Methodology: Second Round*

After processing the information provided by the experts in the first round, the results generated new adjustment guidelines for the questionnaire in the second round. Consequently, a new questionnaire (Appendix Table A2) with the same number of questions was presented. The second round was conducted with the same experts and total number of participants in this validation phase. As a result of the second round of the Delphi survey, a higher reliability of the data was evident with a Cronbach's alpha value above 0.8, which is excellent. This was replicated for experts with greater than 16 years of experience. The sample experts with one to fifteen years of work experience had a score of 0.743. The Kendall's W coefficient in the participant sample, which indicates the level of agreement among the experts, was higher in the overall round compared to the first round (first round  $W = 0.133$ ; second round  $W = 0.140$ ), which demonstrates a better agreement in the second round of the Delphi survey (Table 5).

**Table 10.** Second round of Delphi survey-BIM integration in steel construction projects.

**EXPERTS ROUND 2**

| Code | All the experts in the area |                    | One to fifteen years of experience |       | More than sixteen years of experience |                    |
|------|-----------------------------|--------------------|------------------------------------|-------|---------------------------------------|--------------------|
|      | Mean                        | Standard Deviation | Standard Deviation                 | Mean  | Mean                                  | Standard Deviation |
| Q1   | 4.13                        | 0.336              | 4.20                               | 0.447 | 4.11                                  | 0.320              |
| Q2   | 4.00                        | 0.672              | 4.20                               | 0.447 | 3.96                                  | 0.706              |
| Q3   | 3.97                        | 0.309              | 4.00                               | 0.000 | 3.96                                  | 0.338              |
| Q4   | 4.09                        | 0.296              | 4.20                               | 0.447 | 4.07                                  | 0.267              |
| Q5   | 4.53                        | 0.507              | 4.40                               | 0.548 | 4.56                                  | 0.506              |
| Q6   | 3.97                        | 0.400              | 3.80                               | 0.447 | 4.00                                  | 0.392              |
| Q7   | 4.44                        | 0.504              | 4.40                               | 0.548 | 4.44                                  | 0.506              |
| Q8   | 4.09                        | 0.466              | 4.20                               | 0.447 | 4.07                                  | 0.474              |
| Q9   | 4.06                        | 0.504              | 3.80                               | 0.447 | 4.11                                  | 0.506              |
| Q10  | 4.06                        | 0.435              | 4.00                               | 0.000 | 4.07                                  | 0.474              |
| Q11  | 4.50                        | 0.508              | 4.60                               | 0.548 | 4.48                                  | 0.509              |
| Q12  | 4.63                        | 0.492              | 5.00                               | 0.000 | 4.56                                  | 0.506              |
| Q13  | 4.13                        | 0.609              | 4.00                               | 0.707 | 4.15                                  | 0.602              |
| Q14  | 4.28                        | 0.634              | 4.20                               | 0.447 | 4.30                                  | 0.669              |
| Q15  | 4.56                        | 0.504              | 4.40                               | 0.548 | 4.59                                  | 0.501              |
| Q16  | 4.22                        | 0.608              | 4.40                               | 0.548 | 4.19                                  | 0.622              |
| Q17  | 4.22                        | 0.659              | 4.20                               | 0.837 | 4.22                                  | 0.641              |
| Q18  | 4.44                        | 0.564              | 4.20                               | 0.837 | 4.48                                  | 0.509              |
| Q19  | 4.13                        | 0.609              | 4.20                               | 0.447 | 4.11                                  | 0.641              |
| Q20  | 4.31                        | 0.693              | 4.20                               | 0.837 | 4.33                                  | 0.679              |
| Q21  | 4.19                        | 0.592              | 4.40                               | 0.548 | 4.15                                  | 0.602              |
| Q22  | 4.22                        | 0.553              | 4.00                               | 0.707 | 4.26                                  | 0.526              |
| Q23  | 4.22                        | 0.553              | 4.20                               | 0.447 | 4.22                                  | 0.577              |
| Q24  | 4.38                        | 0.554              | 4.60                               | 0.548 | 4.33                                  | 0.555              |
| Q25  | 4.28                        | 0.457              | 4.40                               | 0.548 | 4.26                                  | 0.447              |

|   |       |       |       |       |       |       |
|---|-------|-------|-------|-------|-------|-------|
| Q26   | 4.09  | 0.390 | 4.20  | 0.447 | 4.07  | 0.385 |
| Q27   | 4.34  | 0.545 | 4.60  | 0.548 | 4.30  | 0.542 |
| Q28   | 4.16  | 0.369 | 4.20  | 0.447 | 4.15  | 0.362 |
| STATISTICAL DATA                                  |       |       |       |       |       |       |
| Cronbach's $\alpha$<br>reliability<br>value       | 0.861 |       | 0.743 |       | 0.875 |       |
| Number of<br>respondents                          | 32    |       | 5     |       | 27    |       |
| Kendall's<br>coefficient of<br>concordance<br>(W) | 0.140 |       | 0.264 |       | 0.139 |       |

Figure 12 presents the IRA results and the significance level of the factors from the second round of the Delphi survey, in addition to the data for the total sample of experts and the ranking of the experts indicated, as shown in the table header. The product obtained in this second questionnaire is more promising and consolidated with respect to the first round, improving the resolution of each question and the result of the reformulated question of code Q2 (Appendix Tables A1, A2). A considerable agreement was observed in the IRA analysis and significance level for the other questions; ranging from a strong to very strong agreement and from very important to extremely important, these factors support the consensus reached by the expert panel after the second round of the Delphi surveys and validate the agreements.

EXPERTS ROUND 2

| Code | All the experts in the area |                       |                     | One to fifteen years of experience |                       |                     | More than sixteen years of experience |                       |                     |
|------|-----------------------------|-----------------------|---------------------|------------------------------------|-----------------------|---------------------|---------------------------------------|-----------------------|---------------------|
|      | avg SCORE                   | Agreement level       | Significance grade  | avg SCORE                          | Agreement level       | Significance grade  | avg SCORE                             | Agreement level       | Significance grade  |
| Q1   | 0.92                        | very strong agreement | very important      | 0.85                               | strong agreement      | very important      | 0.93                                  | very strong agreement | very important      |
| Q2   | 0.71                        | moderate agreement    | very important      | 0.85                               | strong agreement      | very important      | 0.69                                  | moderate agreement    | very important      |
| Q3   | 0.94                        | very strong agreement | very important      | 1.00                               | very strong agreement | very important      | 0.93                                  | very strong agreement | very important      |
| Q4   | 0.94                        | very strong agreement | very important      | 0.85                               | strong agreement      | very important      | 0.95                                  | very strong agreement | very important      |
| Q5   | 0.70                        | moderate agreement    | extremely important | 0.72                               | strong agreement      | very important      | 0.69                                  | moderate agreement    | extremely important |
| Q6   | 0.90                        | strong agreement      | very important      | 0.89                               | strong agreement      | very important      | 0.90                                  | strong agreement      | very important      |
| Q7   | 0.75                        | strong agreement      | very important      | 0.72                               | strong agreement      | very important      | 0.74                                  | strong agreement      | very important      |
| Q8   | 0.85                        | strong agreement      | very important      | 0.85                               | strong agreement      | very important      | 0.85                                  | strong agreement      | very important      |
| Q9   | 0.83                        | strong agreement      | very important      | 0.89                               | strong agreement      | very important      | 0.82                                  | strong agreement      | very important      |
| Q10  | 0.87                        | strong agreement      | very important      | 1.00                               | very strong agreement | very important      | 0.85                                  | strong agreement      | very important      |
| Q11  | 0.72                        | strong agreement      | extremely important | 0.60                               | moderate agreement    | extremely important | 0.72                                  | strong agreement      | very important      |
| Q12  | 0.66                        | moderate agreement    | extremely important | -                                  | not applicable        | not applicable      | 0.69                                  | moderate agreement    | extremely important |
| Q13  | 0.74                        | strong agreement      | very important      | 0.68                               | moderate agreement    | very important      | 0.74                                  | strong agreement      | very important      |
| Q14  | 0.67                        | moderate agreement    | very important      | 0.85                               | strong agreement      | very important      | 0.63                                  | moderate agreement    | very important      |
| Q15  | 0.69                        | moderate agreement    | extremely important | 0.72                               | strong agreement      | very important      | 0.67                                  | moderate agreement    | extremely important |
| Q16  | 0.72                        | strong agreement      | very important      | 0.72                               | strong agreement      | very important      | 0.71                                  | strong agreement      | very important      |
| Q17  | 0.67                        | moderate agreement    | very important      | 0.47                               | weak agreement        | very important      | 0.68                                  | moderate agreement    | very important      |
| Q18  | 0.68                        | moderate agreement    | very important      | 0.47                               | weak agreement        | very important      | 0.72                                  | strong agreement      | very important      |
| Q19  | 0.74                        | strong agreement      | very important      | 0.85                               | strong agreement      | very important      | 0.71                                  | strong agreement      | very important      |
| Q20  | 0.59                        | moderate agreement    | very important      | 0.47                               | weak agreement        | very important      | 0.60                                  | moderate agreement    | very important      |
| Q21  | 0.74                        | strong agreement      | very important      | 0.72                               | strong agreement      | very important      | 0.74                                  | strong agreement      | very important      |
| Q22  | 0.77                        | strong agreement      | very important      | 0.68                               | moderate agreement    | very important      | 0.78                                  | strong agreement      | very important      |
| Q23  | 0.77                        | strong agreement      | very important      | 0.85                               | strong agreement      | very important      | 0.74                                  | strong agreement      | very important      |
| Q24  | 0.72                        | strong agreement      | very important      | 0.60                               | moderate agreement    | extremely important | 0.73                                  | strong agreement      | very important      |
| Q25  | 0.83                        | strong agreement      | very important      | 0.72                               | strong agreement      | very important      | 0.84                                  | strong agreement      | very important      |
| Q26  | 0.90                        | strong agreement      | very important      | 0.85                               | strong agreement      | very important      | 0.90                                  | strong agreement      | very important      |
| Q27  | 0.74                        | strong agreement      | very important      | 0.60                               | moderate agreement    | extremely important | 0.76                                  | strong agreement      | very important      |
| Q28  | 0.90                        | strong agreement      | very important      | 0.85                               | strong agreement      | very important      | 0.91                                  | strong agreement      | very important      |

**Figure 12.** Importance rating and IRA analysis of the factors (benefits) of the second round of experts.

Figure 13 presents the process map resulting from integrating the BIM model in steel construction projects after two rounds of the Delphi method.





**Figure 13.** Final consensus of the BIM integration model in steel building projects after the Delphi survey based on expert agreement.

### **3.5 Discussion and conclusion.**

Considering that the investigations presented in this PhD thesis are complementary to each other, the discussions and conclusions have been grouped in chapter 5 and 6 respectively.

# Chapter 4

## BIM in Steel Building Projects

### Following BIM-DFE Methodology: A Case Study

Authors: José Ignacio Avendaño, Alberto Domingo, Sisi Zlatanova.

Status: Manuscript published

Journal: Buildings 2023

DOI: <https://doi.org/10.3390/buildings13092137>

JCR IF (2022): 3.8

| JCR Category                       | Ranking | Quartile |
|------------------------------------|---------|----------|
| Construction & Building Technology | 23/68   | Q2       |
| Engineering, Civil                 | 46/139  | Q2       |

Presentation: Post-Print (Author version)

**Abstract:** Construction is a key industry that significantly contributes to the global gross domestic product and generates substantial revenues. However, it faces challenges such as errors and high costs. The aim of this study is to demonstrate the methodology of applying building information modeling integration for the design, fabrication, and erection of steel buildings, called BIM-DFE, in a real-world scenario. This is the first study in which this methodology is applied in an actual case. Two steel building projects with similar design typologies were selected. The first project was executed using computer-aided design and traditional BIM techniques during the planning, design, and fabrication phases. The BIM-DFE methodology was applied to the same phases in the second project. The results of the two projects were compared quantitatively. The experiments suggest that the application of the BIM-DFE methodology reduced the development time in the planning phase, incorporated manufacturing constraints in the design phase, and significantly reduced assembly times in the fabrication phase. This study confirmed the feasibility of applying BIM-DFE methodology in an actual case scenario, which is the result of collaboration between the scientific community and the industry in steel building projects.

**Keywords:** building information modeling (BIM); steel building projects; integration model

## 4.1 Introduction

Construction is a key industry that significantly contributes to the global gross domestic product (GDP), accounting for approximately 6% of the global GDP and generating annual revenues of approximately \$10 trillion (Avendaño et al., 2022a). However, the productivity of the construction industry lags compared with that of other sectors (Stojanovska-Georgievska et al., 2022). Historically, the industry has been prone to errors, high costs, and interference. (Bahamid et al., 2022; Basta et al., 2020). Steel structures have recently gained increased attention owing to their strength, durability, and efficiency (Succar, 2009). However, the lack of coordination among the different parties involved in construction projects has become a common problem that causes delays, cost overruns, and low project quality (Avendaño et al., 2022a; Bahamid et al., 2022). This problem is particularly severe in steel construction, where supply chain fragmentation and the lack of communication between engineers, fabricators, designers, and contractors have led to problems in planning, design, fabrication, transportation, and erection (Avendaño et al., 2022a; Avendaño, et al., 2022b; Kamunda et al., 2021; Niu et al., 2017; Turk, 2020). A steel construction project consists of several phases, ranging from material and fabricator selection to the erection and finishing of the structure (Avendaño et al., 2022b; Y. Liu et al., 2021; Sampaio et al., 2023). As the use of steel in construction increases, the complexity of projects also increases, especially in terms of information management (Avendaño et al., 2022b; Ding et al., 2019; Turk, 2020; W. C. Wang et al., 2014). The quality and timeliness of information in different stages of the workflow must be ensured to avoid the repetition of processes and interference and reduce the associated costs and construction time (Turk, 2020; W. C. Wang et al., 2014). The inefficient use of information causes fragmentation of a steel project lifecycle. Therefore, information technologies that facilitate collaboration between the different stages of a

project must be adopted (Kamunda et al., 2021; Niu et al., 2017; Turk, 2020). The development of computer-aided design (CAD) software in the 1980s allowed engineers and architects to create accurate and detailed technical drawings in reduced time (Ozcan Deniz, 2018). The evolution of CAD to building information modeling (BIM) has allowed the creation of detailed three-dimensional (3D) models and a database of project information (Ding et al., 2019; Y. Liu et al., 2021; Ozcan Deniz, 2018; Rashidian et al., 2023; Steel et al., 2012; Succar, 2009; W. C. Wang et al., 2014) for different application in construction (Diakite & Zlatanova, 2020), urban planning (Alattas et al., 2021; Aleksandrov et al., 2019; L. Liu et al., 2021), and indoor navigation (Abou Diakité & Zlatanova, 2016; Isikdag et al., 2013). BIM also promotes collaboration between team members (Azhar & Asce, 2011). It has become a standard tool in the construction and civil engineering industries to improve the efficiency and accuracy in the planning, design, and construction process (Ding et al., 2019; Y. Liu et al., 2021; Ozcan Deniz, 2018; Rashidian et al., 2023; Steel et al., 2012; Succar, 2009; W. C. Wang et al., 2014). In recent decades, the construction industry has undergone a technological revolution; in particular, BIM has become an essential tool that encompasses a series of activities aimed at improving the outcomes of different project stages (Ding et al., 2019; Niu et al., 2017; Ozcan Deniz, 2018; Steel et al., 2012). Although utilizing steel in construction has advantages, the usefulness of BIM has not yet been explored in detail (Avendaño et al., 2022a; Avendaño et al., 2022b). The efficient management in the planning, design, fabrication, transport, and erection phases of a construction project maximizes the benefits of working with steel. However, the lack of coordination between different teams can cause problems (Avendaño et al., 2022a; Avendaño et al., 2022b) The adoption of information technologies that facilitate collaboration between the teams ensures the quality and timeliness of information and reduces the costs and construction time (Avendaño,

Zlatanova et al., 2022a; Avendaño et al., 2022b; Y. G. Wang et al., 2022). The utilization of BIM in steel construction can enhance the coordination between diverse project stakeholders and facilitate efficient information management in all the project phases (Alizadehsalehi et al., 2020; Avendaño et al., 2022a). BIM allows the creation of a 3D digital model that integrates all project-related information, ranging from drawings and technical specifications to costs and planning (Avendaño et al., 2022b; Avendaño et al., 2022a; Costin et al., 2021; Diakite & Zlatanova, 2020; Soh et al., 2022). This enables collaboration between stakeholders by providing access to the same information so that they can work together in real-time to solve problems (Alizadehsalehi et al., 2020; Avendaño et al., 2022a; Disney et al., 2022). However, BIM must be applied with standards and tools that allow the integration of project information (Avendaño et al., 2022b; Jeon et al., 2021; Tang et al., 2020). These standards include the Information Delivery Manual (IDM), which defines the processes, protocols, and formats for information exchange between stakeholders. By following the IDM guidelines, the project information can be standardized (Arayici et al., 2018; Jeon et al., 2021; Sacks et al., 2018). Another important standard is the Industry Foundation Classes (IFC), which enables the exchange and sharing of BIM data between different software and tools used in construction (Qiu et al., 2021; Ramaji et al., 2020; Shan et al., 2012; Wu et al., 2019). Information-sharing between stakeholders in a construction project improves the communication efficiency and reduces errors and misunderstanding (Avendaño et al., 2022a; Avendaño et al., 2022b; Qiu et al., 2021; Ramaji et al., 2020; Tang et al., 2020; Wu et al., 2019). The CAD-BIM methodology is an integrated approach that combines CAD and BIM to enhance the design and construction processes in the architecture, engineering, and construction industry. This methodology has proven to be effective in information management for steel construction projects. However, it is unable to solve all the problems

encountered in the industry (Bartenbach et al., 2019; Tavares et al., 2019). In contrast, BIM for the design, fabrication, and erection of steel buildings, abbreviated BIM-DFE (Avendaño, et al., 2022b), considers the lifecycle of a project with emphasis on early integration. It focuses on the fabrication process, which accounts for the largest resource expenditures (Avendaño et al., 2022a; Avendaño et al., 2022b). The CAD-BIM methodology has been widely used by the construction industry, with IDM as a guide for deliverables and IFC for information transfer in general construction projects (Jeon et al., 2021; Pan & Zhang, 2022; Ramaji et al., 2017; Sibenik & Kovacic, 2020; Son et al., 2022; Vaughan et al., 2013). However, these tools have failed to fully integrate the benefits of BIM into other construction subprocesses (e.g., steel construction) owing to their holistic nature [9]. Recent studies on the application of BIM in steel construction (e.g., BIM-DFE) have been validated by the academic community and industry. A Delphi study showed that the BIM-DFE methodology enhanced the utilization of BIM in steel construction projects (Avendaño et al., 2022b). However, the methodology has not been tested in real-world cases. Therefore, one of the primary objectives of this study is to assess the applicability of recent methodologies related to BIM and steel construction in real-world scenarios (Lucko et al., n.d.; Vaughan et al., 2013).



## 4.2 BIM-DFE

BIM for the design, fabrication, and erection of steel buildings (BIM-DFE) is a comprehensive approach that integrates digital technologies and collaborative workflows to optimize steel construction projects. The BIM-DFE method can facilitate communications between all the parties involved (e.g., client, designers, fabricators, erectors, etc.) to ensure the success of the project. It leverages BIM at all stages of the steel construction lifecycle. A 3D BIM model is fed with information at different stages of the project (e.g., planning, design, fabrication, transportation, and erection) (Avendaño et al., 2022b). Information is transferred using open BIM collaboration files in the IFC format, as it plays a crucial role in ensuring efficient data exchange and enabling integration among diverse software platforms. The use of BIM in planning and design is crucial to obtain a clear understanding of the costs of fabrication, transportation, and erection of steel structures. The BIM-DFE approach emphasizes the integration of stakeholder resources from the outset to achieve the optimal design. This integration focuses on the planning and design phases, in which preliminary analyses were conducted to improve the understanding of decision-makers. BIM models should include relevant information for the transportation simulation in the design phase. This allows the classification and tracking of the components to be transported, which enables the prioritization of transportation according to the needs of the project. Although this information is often excluded, its inclusion can have a significant impact on the total cost of the project (Avendaño et al., 2022a; Avendaño et al., 2022b).

#### **4.2.1. BIM-DFE Steel Planning Phase**

To effectively manage a project, the project type (industrial, commercial, public, etc.) must be selected in the planning phase. A notable process in BIM-DFE is the selection of a project manager to assume the role of a design engineer, who possesses skills and experience in BIM projects. If no qualified project manager is found, then another search is conducted. This is a basic requirement because the project manager is tasked with generating the 3D estimation model (Avendaño et al., 2022a).

#### **4.2.2. BIM-DFE Steel Design Phase**

In the design phase, the model is analyzed for the purpose of optimization. Once the model is optimized, a meeting is held with the client to determine the resources consumed by optimization. The model is optimized until it is approved by the client. Then, the design team verifies the connections using specialized software. When the entire model is approved, it goes through several stages and sequences so that the information in the model can be easily understood by the fabrication team. This model is called the Steel BIM-DFE model (Avendaño et al., 2022a).

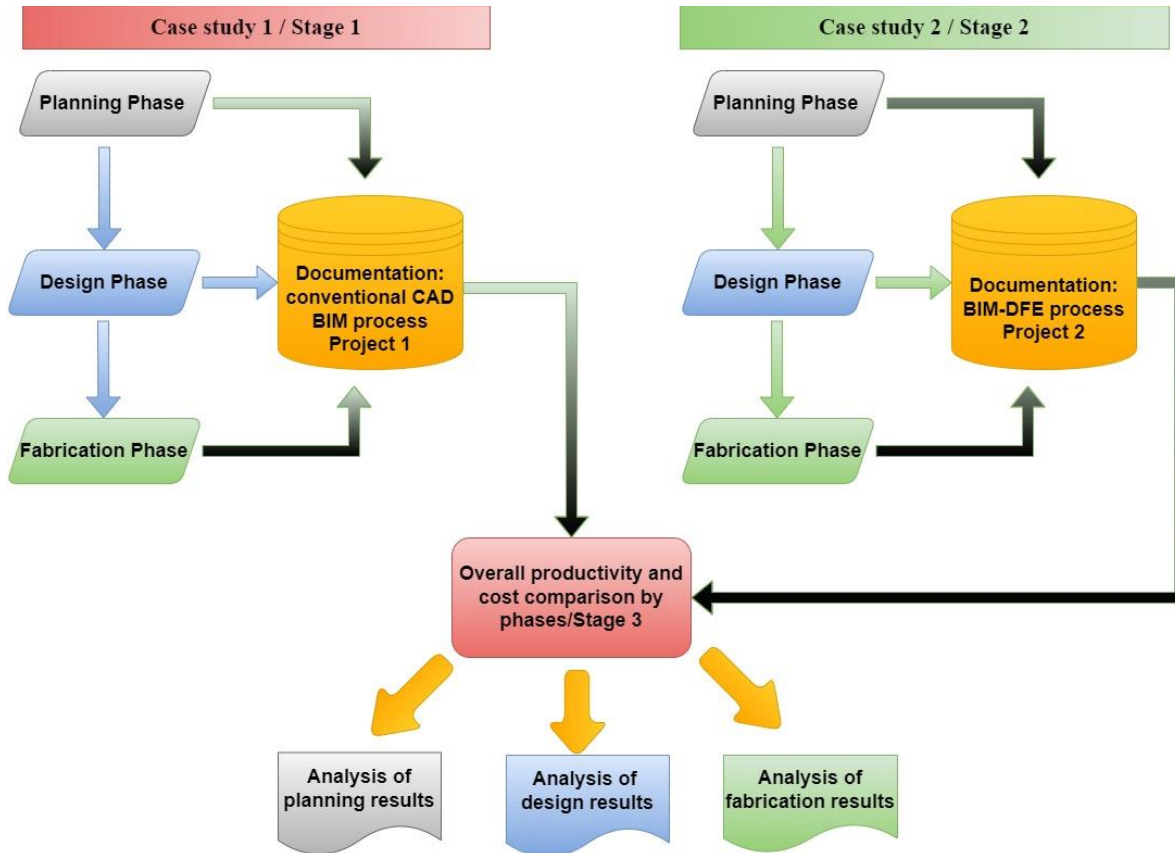
#### **4.2.3. BIM-DFE Fabrication Phase**

In the fabrication phase, detailed engineering and planning for fabrication are simultaneously conducted to optimize the transportation resources. Then, the components are fabricated, and the final 3D model approved in the previous phases is generated. This model is shared through the common data environment to provide information to stakeholders (Avendaño et al., 2022a). Given the current state of the steel construction industry and the significance of BIM in this context, the primary objective of this study is to conduct a

comparative analysis between the traditional CAD-BIM methodology and the specific BIM-DFE methodology for steel construction. This comparative analysis is accomplished by applying both methodologies to two selected case studies and rigorously examining and comparing their respective quantitative productivity indicators across the critical phases of planning, design, and fabrication. These phases represent pivotal stages in which crucial decisions are made in steel construction projects. Through this in-depth comparative analysis, the study aims to evaluate the impact of the methodologies, providing valuable academic insights that can inform decision-making processes and contribute to the optimization of performance within the field of steel construction.

#### **4.3. Research Methodology**

The objective of a case study is to identify the relationship between the causes and effects of conditions applied in a certain process and to replicate the advantages in similar processes (Vaughan et al., 2013). The data collected from the selected projects are used to conduct a comparative analysis of the costs and benefits (Pan & Zhang, 2022) of the BIM-DFE integration methodology in the planning, design, and manufacturing phases of steel construction projects. The following workflow was applied in this study: (1) documentation of the processes in Project 1 (case study 1) using the traditional CAD-BIM methodology; (2) documentation of the processes in Project 2 (case study 2) using the BIM-DFE integration methodology; and (3) comparison of the overall productivity of different phases. The research workflow is shown in Figure 14.



**Figure 14.** Outline of the methodology.

#### 4.3.1 Process Comparison and Scope of Analyses

Two cases were compared in the quantitative analyses of the BIM-DFE method. A follow up analysis was conducted on two actual steel construction projects during the planning, design, and manufacturing phases. In Project 1, the conventional CAD-BIM integration methodology was applied in the planning and design phases. In Project 2, the BIM-DFE integration

methodology was applied, considering its early integration in the planning phase and the modeling tools validated by steel industry experts as fundamental to integration.

To conduct an accurate quantitative comparison, projects with a similar typology and function were commissioned by the same client for the same teams (i.e., planner, designer, engineer, and manufacturer). The team categorized the difficulty level both projects as 6 on a scale of 1–10. This was used to reduce the variables that could affect the results of the study (Table 11). The quantification of time allocation in each project was obtained through the documentation of daily activities performed by workers. This record provided precise data regarding the hours assigned to individual workers for each project, focusing primarily on the planning and design phase. In the subsequent fabrication phase, a log daily productivity was maintained, encompassing the recorded hours of machinery and workstation utilization dedicated to each project. Furthermore, this log was complemented with the registration of tonnage allocated to each workstation, facilitating the calculation of production output in terms of tons per hour for each segmented workstation within each project.

**Table 11.** Characteristics of the case study projects.

| <b>Characteristics</b>  | <b>Case Study 1</b>     | <b>Case Study 2</b>     |
|---|-------------------------|-------------------------|
| Location  | Buenos Aires, Argentina | Buenos Aires, Argentina |
| Type of project   | Industrial              | Industrial              |
| Square meters   | 1665                    | 11,000                  |
| Tons  | 63.34                   | 304.2                   |
| Type of connections   | 90% bolted/10% welded   | 90% bolted/10% welded   |
| Project complexity  | 6 out of 10             | 6 out of 10             |
| Project cost (planning, steel design, fabrication, and raw materials) | 285,030 USD             | 1,368,900 USD           |

The projects are located in Buenos Aires, Argentina. In the construction industry, the development and execution times are key indicators of the project performance (Alattas et al., 2021). Therefore, after the application of the traditional CAD-BIM and BIM-DFE methodologies, the benefits were quantified based on the average time required to perform each of the processes in each phase (Bartenbach et al., 2019b; Sampaio et al., 2023)..

#### 4.4. Case Study 1 CAD-BIM Application.

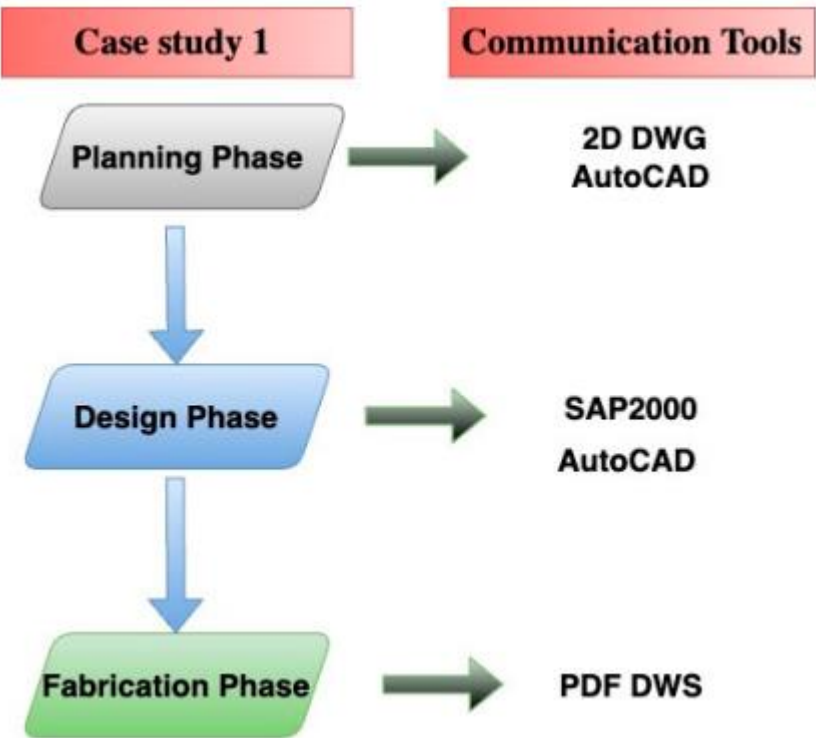
Project 1 encompasses a steel construction featuring a spectrum of structural components, including columns, beams, rafters, vertical and horizontal bracing, walls, and roof rafters (Figure 15). Detailed project characteristics are provided in Table 1.



**Figure 15.** Details of case study 1.

The methodology used in this study was supported by CAD and BIM technologies implemented in the aforementioned phases of the steel structures. AutoCAD 2019 and SAP2000 were used as the tools in case study 1, as shown in Figure 16. The team involved

in the planning and design phases includes a project manager who also assumed the roles of the senior designer, a junior engineer, senior draftsman/modeler, and two draftsmen. Engineers were classified as either junior or senior depending on their years of experience: more than 10 years for senior and less than 10 years for junior engineers. They were considered CAD or BIM experts if they had participated in at least 20 steel structure projects that used CAD or BIM as design or planning tools. Table 12 lists the classification of the team members by their role and participation in each stage.



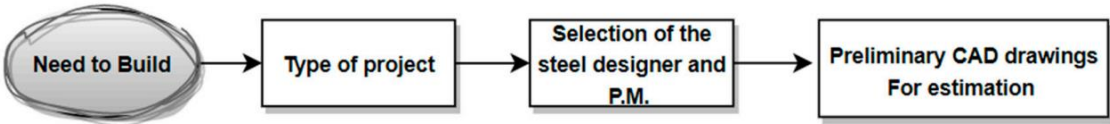
**Figure 16.** Description of tools used for case study 1.

**Table 12.** Team members in planning and design stage

| Team Member | Project Manager | Senior | Junior | Participation Stage |        | Expertise Area |     |
|-------------|-----------------|--------|--------|---------------------|--------|----------------|-----|
|             |                 |        |        | Planning            | Design | CAD            | BIM |
| Engineer 1  | ✓               | ✓      |        | ✓                   | ✓      | ✓              | ✓   |
| Engineer 2  |                 |        | ✓      |                     | ✓      | ✓              | ✓   |
| Draftsman 1 |                 | ✓      |        | ✓                   | ✓      | ✓              | ✓   |
| Draftsman 2 |                 |        | ✓      |                     | ✓      |                | ✓   |
| Draftsman 3 |                 |        | ✓      |                     | ✓      |                | ✓   |

**4.4.1. Planning Phase (Phase 1)**

The roles and responsibilities of the project team are established, and potential risks that could affect the completion of the project are identified. In addition, the project type and designer are selected, the necessary resources are defined, and the decision-making and change management procedures for the entire project are established. In short, the planning phase lays the foundation for the entire project and sets up the framework for success. Each of the subprocesses in the planning phase of Project 1 is detailed as follows. The first subprocess is the intent to build, as shown in Figure 17, which is decided by the client. In this subprocess, the objectives and requirements of the project are established. The feasibility of building the structure in the proposed location is also evaluated by considering factors such as the availability of land, required permits, and capacity to absorb work from the company.

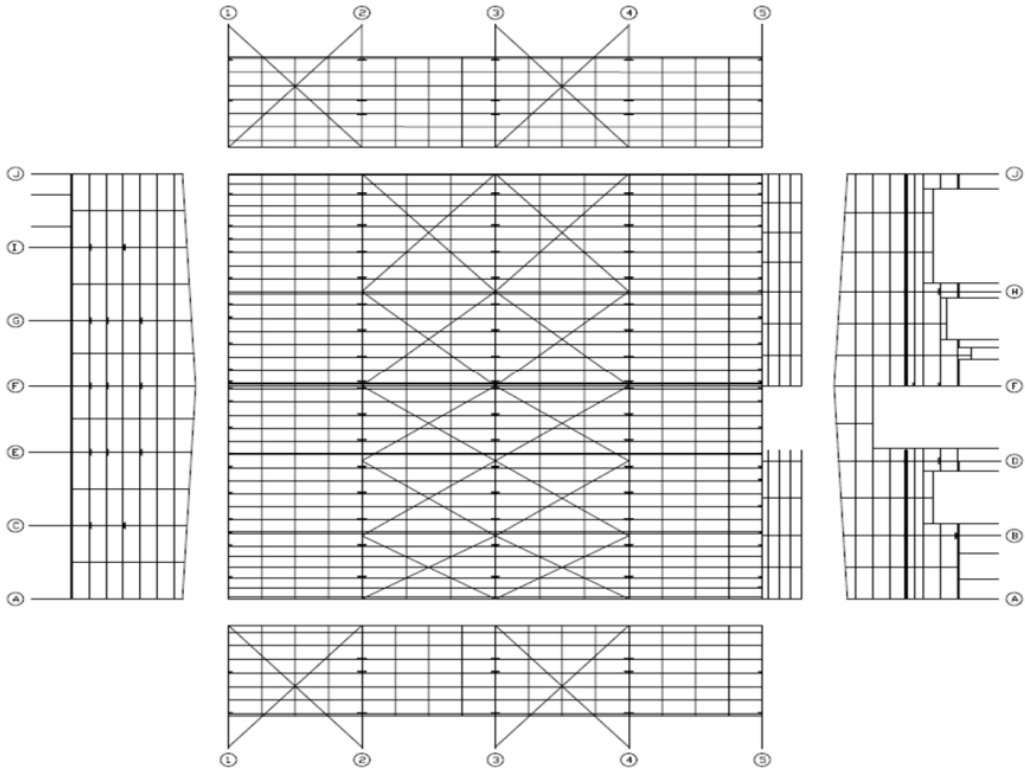


**Figure 17.** Planning subprocess (case study 1).



The second subprocess is selecting the type of project that meets the needs of the client and the capabilities of the company being studied. The main objective is to determine whether the project should be industrial or commercial according to the specifications and requirements of the client. Factors such as the project location, and the size, complexity, and end-use of the structure were analyzed. The project type was categorized as industrial. To proceed to the next step, the available resources (e.g., personnel to conduct design and manufacturing) were also considered. Determining the right project type is essential to meet client expectations and ensure project profitability. The third subprocess is selecting the designer and project manager, which requires a professional with extensive experience in the type of project selected (i.e., industrial projects). This individual must possess skills and knowledge in project management. Choosing the right person for the job is crucial to the success of the project as this individual will be responsible for leading and coordinating the team throughout the project. The selection process includes evaluating the skills and experience of various candidates within the team. It is important that the designer and project manager have the ability to work with clients to understand their needs, translate these into technical specifications, coordinate the team, and ensure that deadlines and budgets are met. A designer with experience in industrial projects must be selected because of the need to modify the design to meet the client's needs. This individual also plays the role of the project manager who ensures coherent and cohesive teamwork. The fourth subprocess is the preliminary CAD drawing. This involves creating two dimensional (2D) planimetry to serve as the basis for estimating the number of tons to be processed and, therefore, the final budget of the project. This task is performed by a senior designer, who also assumes the roles of a project manager and senior draftsman who works for 60 and 80 h, respectively, to produce deliverables. Once completed, the planimetry and budget are presented to the client. The

delivery of these documents completes the subprocess. Figure 18 shows sample CAD drawings



**Figure 18.** Computer-aided design (CAD) estimation drawings (case study 1).

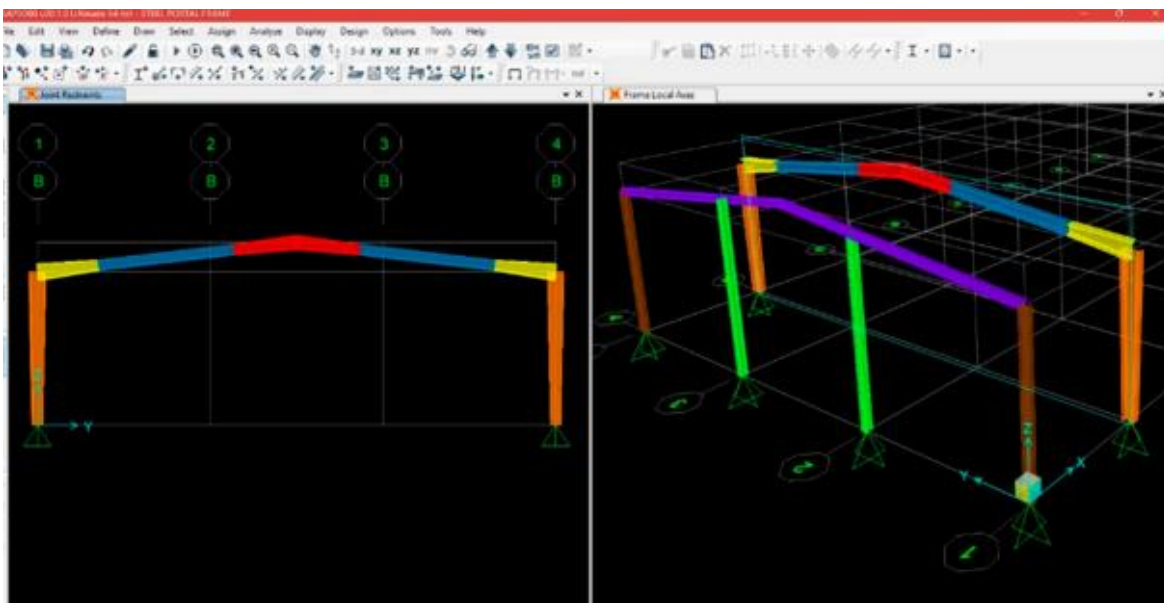
**4.4.2. Design Phase**

The design phase in case study 1 includes a series of subprocesses, as shown in Figure 19. The first subprocess is the entry of information from the CAD model in the previous phase into the SAP2000 software. The model is used to perform structural engineering calculations to determine the load capacity of the structure. A thorough review of the results was then conducted, followed by the required modifications to the model, including the materials selected and structural specifications. The available options were evaluated, and the section

sizes that suit the needs of the project were selected, as indicated by the 3D analytical model in Figure 20. In this subprocess, a senior engineer was required to work for 80 h.



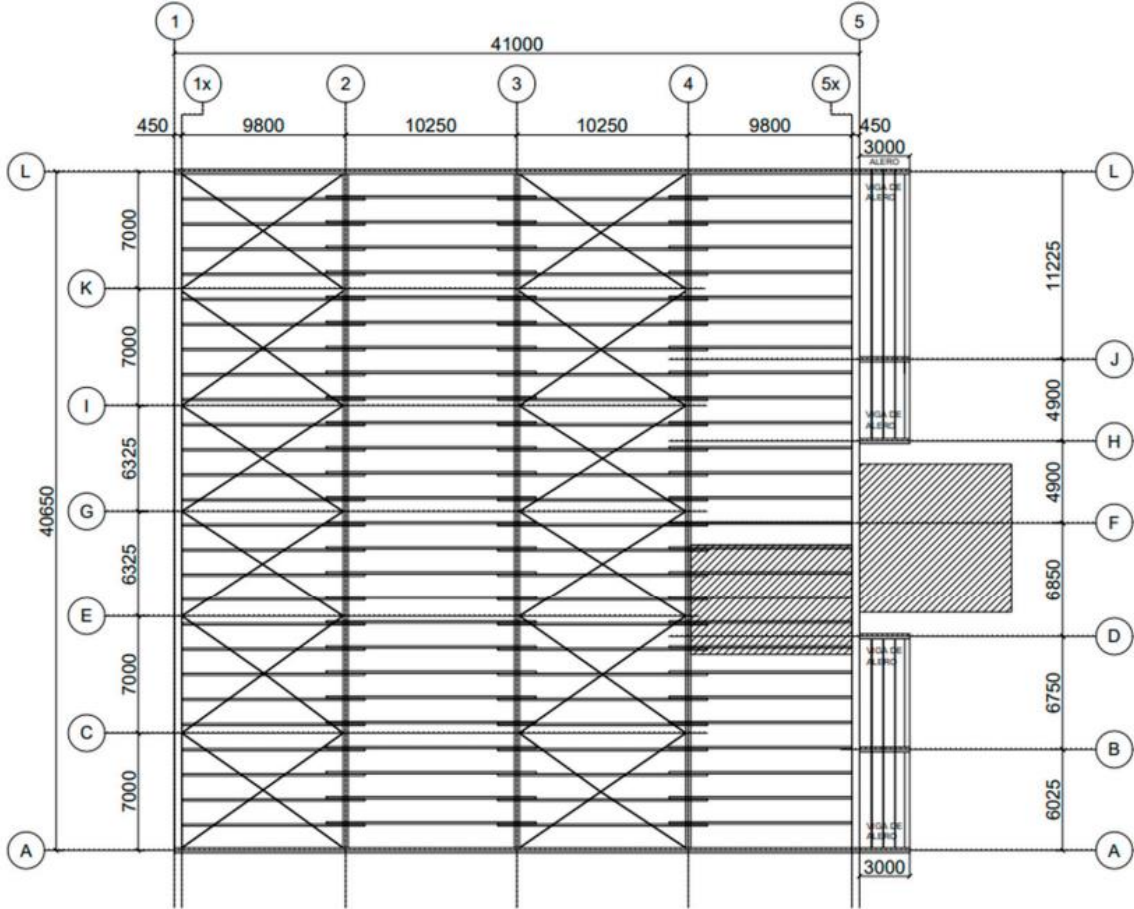
**Figure 19.** Design subprocess (case study 1).



**Figure 20.** Three-dimensional analytical model sample (case study 1).

In the second subprocess, 2D preliminary drawings were created by transferring all the graphical designs (2D drawings of floor plans, elevations, and other details) made in AutoCAD (2D), as shown in Figure 21 (preliminary floor plan). This process consumed a total of 100 h: 60 h by the senior draftsman and 40 h by the junior draftsman. The third subprocess is obtaining the client's approval of the design. The drawings were initially sent to the client. However, owing to the client's failure to understand the planimetry

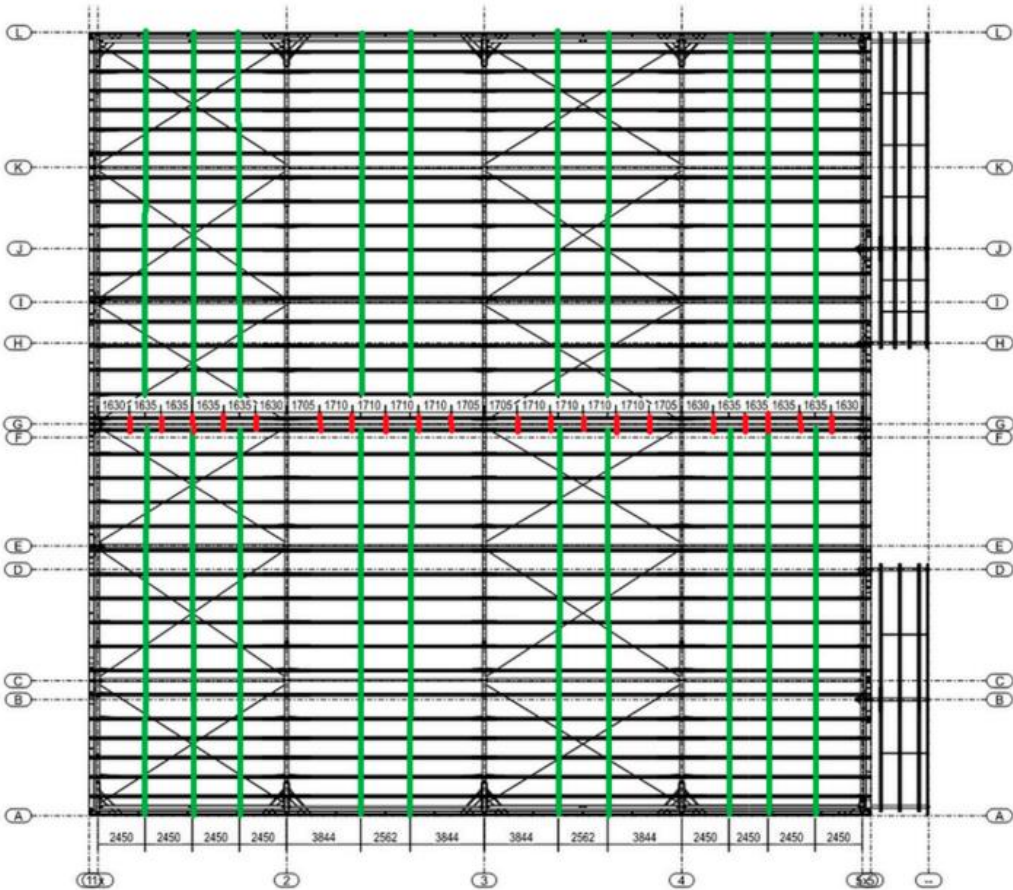
interpretation, the drawings were rejected. Thus, the senior engineers had to meet with the client and explain the drawings and present a new proposal. The second proposal, depicted in Figure 22, was accepted by the client, who also approved the advancement to the next subprocess. This subprocess required a total of 45 and 35 h for engineering and drawing, respectively.



**Figure 21.** Two-dimensional preliminary plan (case study 1)



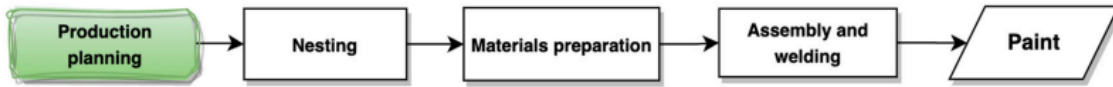
The final subprocess in the design phase is generating the 2D CAD drawing, as shown in Figure 19. Information on the steel connections was incorporated together with the floor plans, axis elevations, and other details for the manufacturing process, as shown in Figure 24. This subprocess required 30 h each from the senior and junior draftsmen



**Figure 24.** Sample 2D CAD drawing (case study 1).

**4.4.3. Fabrication Phase**

Subsequently, the fabrication phase is elucidated according to Figure 25



**Figure 25.** Fabrication subprocess (case study 1)

The team tasked with building the structure in Projects 1 and 2 included an engineering supervisor with 18 years of experience, who managed quality control in the entire fabrication phase from planning to painting, as shown in Figure 25. The first subprocess is production planning, which was assigned to Engineer 2 with 12 years of experience. In this subprocess, the information obtained in the previous phase was used to make the necessary purchases. The information from the 2D plans was used to estimate the amount of steel required and generate the purchase orders for the raw materials. Engineer 2 was also tasked with extracting the information on raw materials from the 2D drawings, which took 40 h. This is the first subprocess in the fabrication phase, as shown in Figure 25. The second subprocess is nesting, which was performed to optimize the raw materials for the fabrication of the structure. This process was performed using AutoCAD, which required an additional 20 h of work from Engineer 2. The third subprocess is material preparation, which was performed by two operators who transferred information from the previous subprocess, i.e., from “Nesting”, to the computer numerical control (CNC) plasma (Figure 26), which was used to cut the plates for processing. The operators were also tasked with cutting, roughing, chamfering, and drilling the subcomponents of the structural assemblies. This subprocess involved two factory operators who worked an average of 2.5 h/t



**Figure 26.** Material preparation using computer numerical control (CNC) plasma sample (case study 1).

The fourth subprocess is assembly and welding (Figure 25), in which parts from the previous stage were gathered at a specific location with sufficient space to present the parts and with only a small weld bead provided, as shown in Figure 27. Finally, the assembled components were welded, which required an average.



**Figure 27.** Preassembly



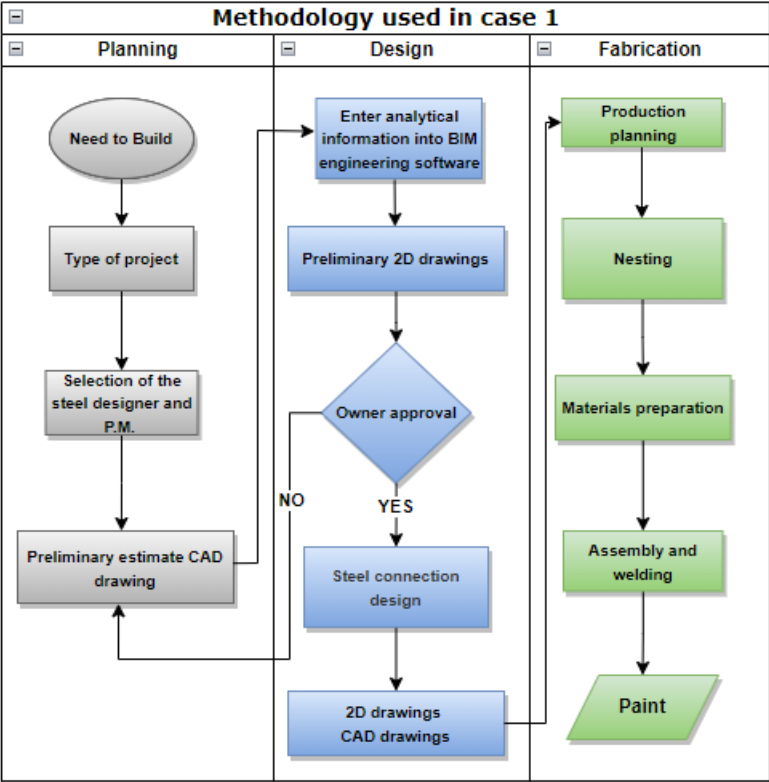
The final subprocess is painting, which was applied according to the specifications. Two workers were tasked with painting and cleaning the residues, which took 0.5 h/t.

Table 13 presents a detailed breakdown of the subprocesses in the fabrication phase. These include production planning, nesting, material preparation, assembly and welding, and painting. The table also lists the professionals responsible for overseeing and ensuring the quality of each subprocess, and the technical staff who execute each task. The comprehensive breakdown of each subprocess provides a thorough understanding of the fabrication phase and a clear framework for its execution.

**Table 13.** Details of subprocesses and personnel involved in the manufacturing subprocess.

| <b>Manufacturing Subprocesses</b> |                            |                |                             |                             |                 |
|-----------------------------------|----------------------------|----------------|-----------------------------|-----------------------------|-----------------|
| <b>Team Member</b>                | <b>Production Planning</b> | <b>Nesting</b> | <b>Material Preparation</b> | <b>Assembly and Welding</b> | <b>Painting</b> |
| Engineer 1 Supervisor             | √                          | √              | √                           | -                           | √               |
| Engineer 2 Planning               | √                          | √              | -                           | -                           | -               |
| CNC Operator 1                    | -                          | -              | √                           | -                           | -               |
| Operator 2                        | -                          | -              | √                           | √                           | -               |
| Operator 3                        | -                          | -              | -                           | √                           | -               |
| Operator 4                        | -                          | -              | -                           | √                           | √               |
| Operator 5                        | -                          | -              | -                           | -                           | √               |

Figure 28 displays a flowchart of the CAD-BIM methodology used in case study 1, which consists of three phases (planning, design, and fabrication) and their corresponding subprocesses. The flowchart includes a breakdown of the subprocesses, such as material preparation, assembly and welding, and painting. The methodology employed provides a visual representation of the different tasks and personnel involved in each phase.



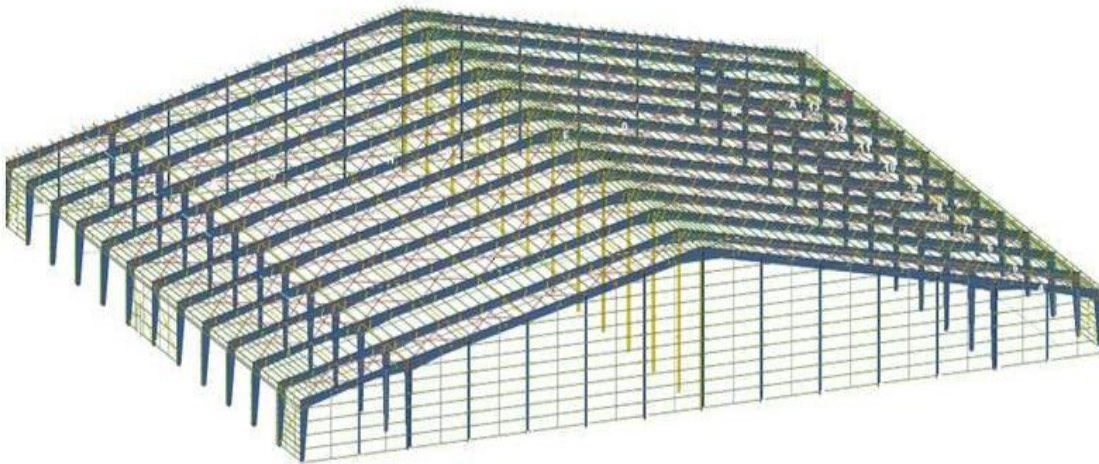
**Figure 28.** Flowchart of the CAD-BIM methodology used in case study 1.

In case study 1, significant challenges were identified across different project stages. During the planning phase, difficulties arose in coordinating and allocating resources. In the design stage, insufficient communication with the client and a lack of optimization in the analysis

model became evident. Additionally, in the fabrication phase, the lack of connectivity between CAD plans and CNC machinery posed challenges.

#### 4.5. Case Study 2: BIM-DFE Application.

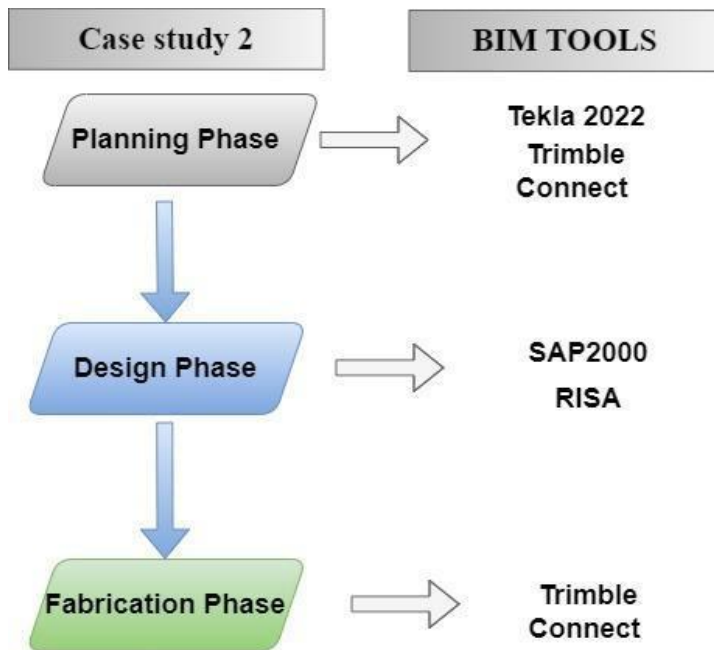
Project 2 encompasses a steel construction, showcasing a range of structural components similar to Project 1 (Figure 29). Detailed project characteristics are provided in Table 11.



**Figure 29.** Isometric case study 2.

The BIM-DFE methodology was applied in all three phases. The tools used were Tekla, SAP2000, and RISA (Avendaño et al., 2022b), as shown in Figure 30. The team that developed the project during the planning and design phases included the project manager, who also fulfilled the role of senior designer; one junior engineer, one senior draftsman/modeler, and two detail draftsmen. The classification of juniors and seniors was based on years of experience. Individuals with over 10 years of experience were classified as seniors, while those with less than 10 years were juniors. Finally, they were classified as CAD or BIM based on their participation in at least 20 steel construction projects that used

CAD or BIM as design or planning tools. Table 12 lists the team members according to their roles and participation in each phase.



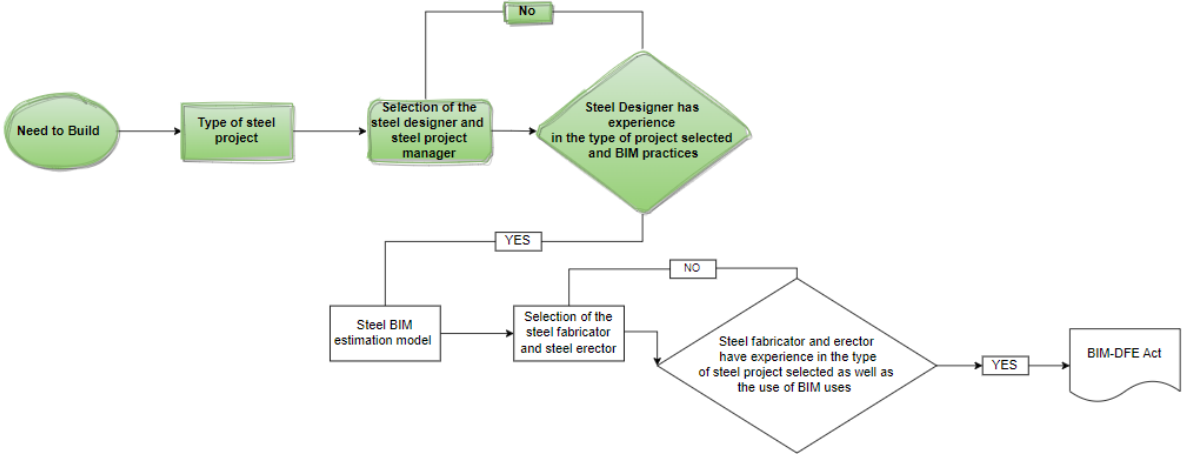
**Figure 30.** Description of tools used for case study 2.

#### 4.5.1. Planning Phase for Case Study 2.

In case study 2, similar to case study 1, the project began with the client's intention to build the structure, followed by the identification of the project type; in this case an industrial project. Then, the designer was selected to play the role of the project manager and provide the client with technical assistance throughout the project.

A key element of the BIM-DFE approach is the careful selection of the team that will implement the project based on their experience in the type of project selected and the use of

BIM models for steel structures, as indicated in Table 12. Accordingly, a thorough search was conducted for the designer who would interact with the client Figure 31. The designer was required to have at least five years of experience in industrial projects and should have managed at least 10 projects using BIM.



**Figure 31.** Planning processes for case study 2.

**BIM Estimation**

In the planning phase of the project, the subprocess of developing the BIM estimation model was conducted using the Tekla Structure 2022 tool. The main objective is to determine the geometric scope of the project in collaboration with the client to avoid wasting time on this task once the calculations for the structure were completed. The BIM estimation model made it possible to accurately determine the amount of steel to be manufactured and assembled, thereby accelerating quotations from the manufacturers, transporters, and assemblers. In the implementation of the estimation model, the model created in Tekla Structure was exported



## Selection of the Steel Fabricator

In-line with the BIM-DFE methodology, manufacturer selection is crucial to the successful execution of the project. An experienced manufacturer is required, i.e., with experience in industrial projects and the ability to utilize the BIM model from the early stages of the project. Therefore, it is important to consider the following characteristics in manufacturer selection.

First, the fabricator must have CNC machinery that allows the nesting of steel components to be fabricated in the material preparation subprocess to facilitate the optimization of resources and reduce production times.

Second, the fabricator must have a manufacturing-enterprise resource planning (MERP) software to manage the purchasing of raw materials to be manufactured using the nesting process in the BIM model. This allows more efficient management of the purchasing process and reduces the time required for raw material acquisition. In such cases, STRUMIS software can be used.

Third, production control that can be applied in Trimble Connect or in the same MERP is required to ensure the transparency of the manufacturing process for the benefit of stakeholders. This improves the control and monitoring of the production process.

Finally, the Tekla model is expected to be used by manufacturing inspectors as well as assembly and welding operators to facilitate their understanding of the geometry of various assemblies. This allows for more accurate and efficient execution of the project.

In summary, manufacturer selection is critical to the successful application of the BIM-DFE methodology. It is important to find a manufacturer with the aforementioned characteristics

to ensure the efficient and effective management of the project using the BIM-DFE methodology.

### BIM-DFE ACT

To finalize the estimation process using the BIM-DFE methodology, a BIM-DFE ACT report was generated (Figure 31), which identifies the following characteristics of the planning process:

All parts and components of the project were modeled according to the requirements of the client, considering the restrictions of the geographical location of the project. All the necessary information for cost estimation and control were included, such as the quantity and type of materials, and the location and quantity of components.

The model was shared with the project manager and client for review and feedback.

The manufacturer selected for the application of the BIM-DFE methodology has the following characteristics:

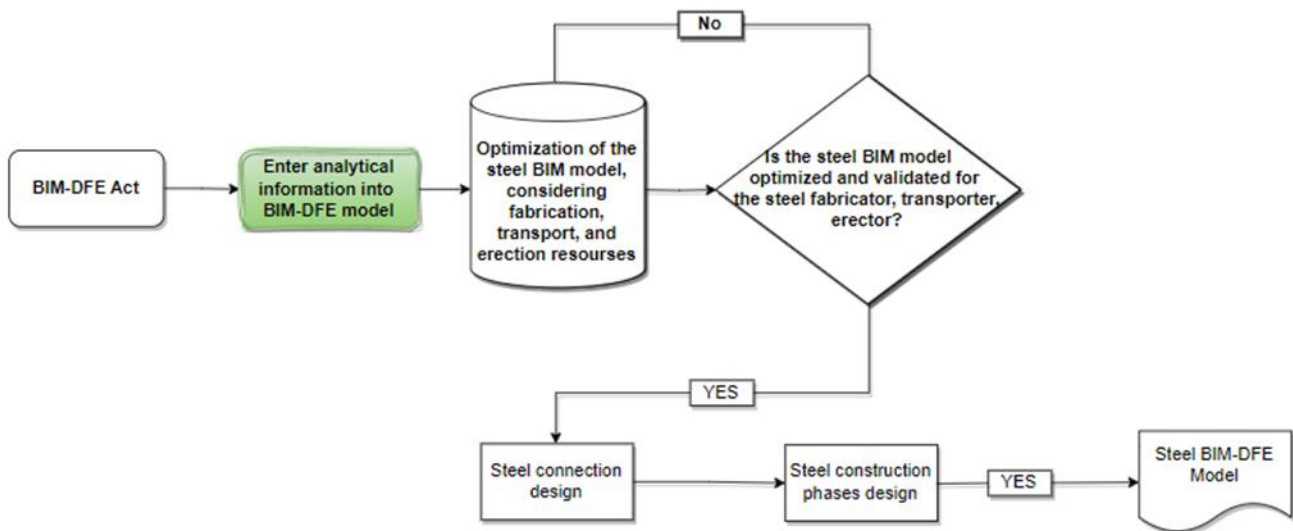
- Experience in the type of project selected, i.e., industrial projects;
- CNC machinery for the preparation of the material and a MERP to manage the purchase of raw materials;
- Transparent production control that discloses the progress of the manufacturing process to other stakeholders.
- Use of the Tekla model to facilitate the understanding of the geometry of different assemblies by the manufacturing inspectors and assembly and welding operators.

Finally, the estimation process was completed in 40 h by a senior engineer



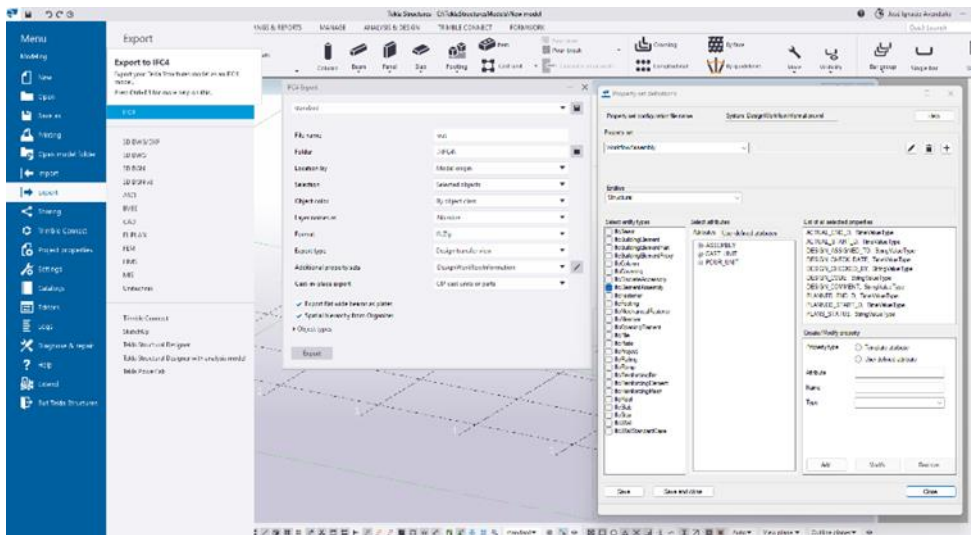
#### 4.5.2. Design Phase Using BIM-DFE

Analytical Information Input into the BIM-DFE Model. The first subprocess in the design phase is to input the analytical information into the BIM-DFE model, as shown in Figure 33.



**Figure 33.** Design process for case study 2.

Interoperability between the design and structural analysis software is essential to ensure the efficiency and accuracy of the analytical model. In this regard, the IFC Tekla model from the previous stage was proven to be a significantly useful tool for the transfer of information between project planning and its analysis and design, as shown in Figure 34.

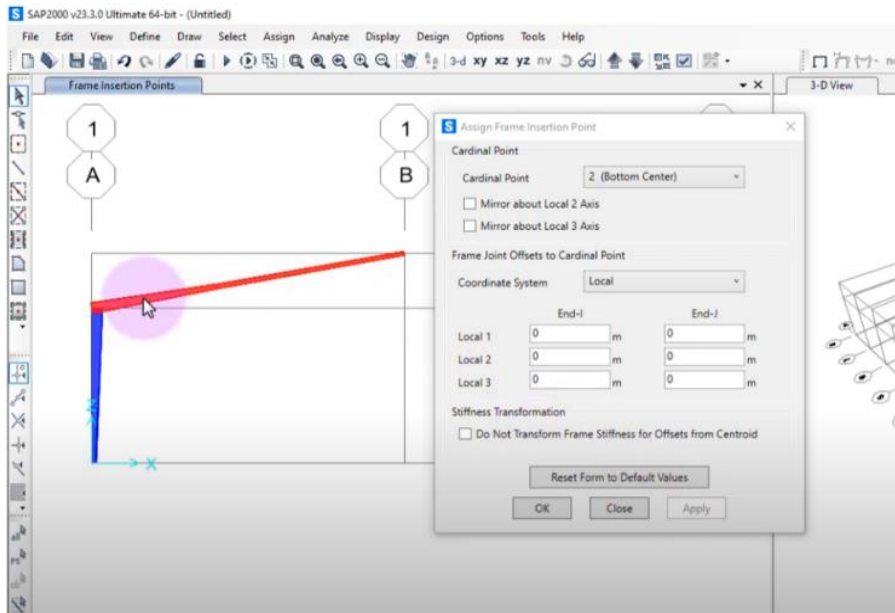


**Figure 34.** IFC configuration from the Tekla structure.

The transfer of IFC models between Tekla and SAP2000 for the load analysis was highly beneficial. This was achieved by satisfying certain characteristics of the model, such as precision, consistency, data hierarchy, clear identification of components, and detailed properties of the components in the estimation stage. These requirements ensured that the model transferred from the estimation to the design stage is complete, accurate, and easy to analyze.

In SAP2000, a complete structural analysis was performed to verify the wind, snow, and earthquake loads along with the live and dead loads of the structure, while considering the geographical location of the project. Local design codes and standards were considered to ensure that the structure met safety and regulatory requirements.

Figure 35 shows the model analyzed in SAP2000 to ensure that the structure is safe and meets the design requirements.



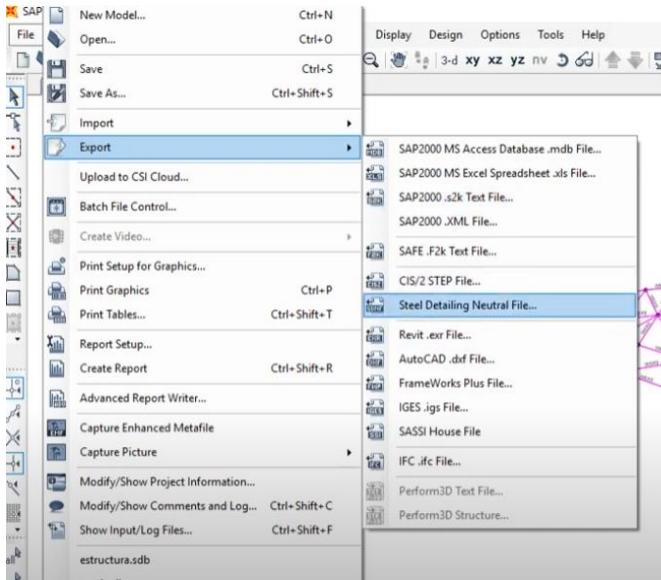
**Figure 35.** Sample analysis of model in SAP2000.

The analysis in SAP2000 allowed the engineer/project manager to optimize the structure to meet the security and efficiency requirements. Design changes were made to meet the load requirements without compromising the integrity or undermining the original design approved by the client. This subprocess required 20 h from the engineer/project manager.

### Optimization of the Steel Structure

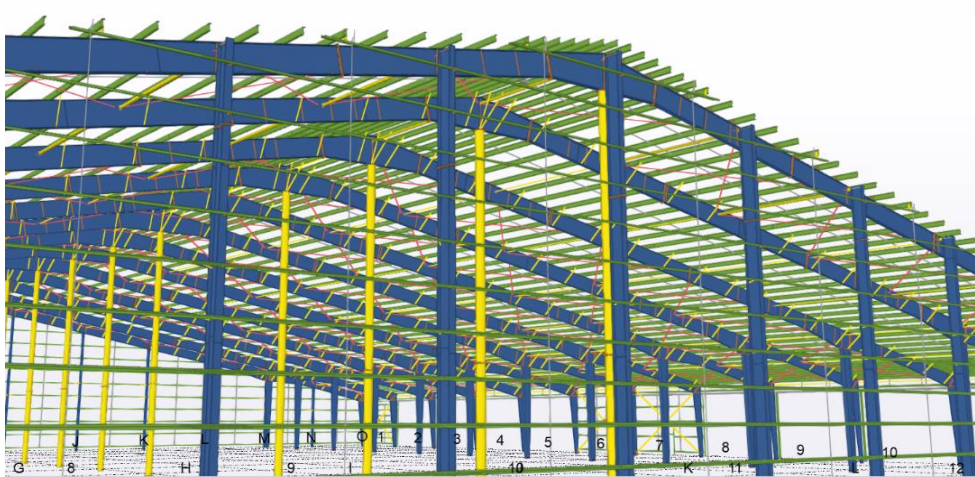
Once the structural model was validated in the design and analysis stage using SAP2000, it was optimized by considering the manufacturer resources, as shown in Figure 33.

This was achieved by exporting the model from SAP2000 to Tekla in the IFC format, as shown in Figure 36.



**Figure 36.** SAP2000 export to Tekla structure by Steel-Detailing Neutral File.

Subsequently, the factory manager (manufacturing) was asked to validate the Tekla model along with the engineer and project manager. The length restrictions of the materials to be processed and optimization of factory resources were considered. In this process, engineer and project manager spent 12 h, while the senior manager (manufacturing) spent 8 h, for a total of 20 h. A Tekla model optimized for the factory characteristics was obtained, as shown in Figure 37.

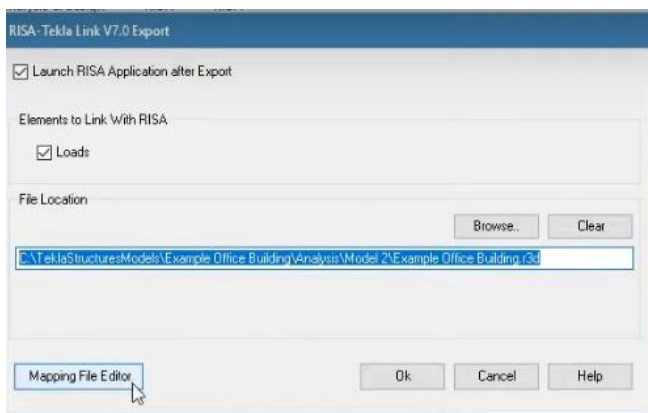


**Figure 37.** Optimized Tekla model.

The validation and optimization of the Tekla model allowed the identification of potential problems and optimization of the manufacturing process. Because of the collaboration between the engineers and senior manufacturing managers, the Tekla model remained within the factory constraints, thus improving the efficiency of the manufacturing process. This process also allowed structural engineers and fabricators to collaborate in the optimization of the structural model, resulting in a more efficient and accurate final structure.

### Steel Connection Design

After optimizing the Tekla model for manufacturing the structural components, the structural connections were validated, and the fabrication phases identified (Figure 19). The tool used was the RISA 3D software. The information transfer between Tekla and RISA 3D was performed by extending RISA 3D to Tekla, as shown in Figure 38.



**Figure 38.** Steel connection import and export to and from RISA 3D.

The validation of structural connections is a critical process in structural design because such connections are subjected to the highest stress and could be the most vulnerable to failure if designed incorrectly. In other words, the connections must be validated to ensure the safety and efficiency of the structure.

In this process, the senior engineer/project manager is in charge of validating the structural connections using the RISA 3D software. The connections were validated for 10 h, during which they were thoroughly checked to ensure that they meet safety and efficiency requirements.

The validation of structural connections ensures their integrity and their adequate design and dimensions to support the applied loads and forces. Finally, in collaboration with the manufacturing manager, the manufacturing phases and sequences were established with the aim of prioritizing the production of structural components according to the factory constraints. At this point, the 3D model had a level of detail (LOD) of 400. This process made it possible to identify production bottlenecks and determine preventive and corrective measures to ensure the efficiency of the manufacturing process and compliance with established deadlines. Collaboration between the structural engineers and manufacturing manager was essential to the success of this process as it allowed the optimization of the manufacturing process and reduction of costs and delivery durations. These steps required a total of 25 h, i.e., 15 h and 10 h from the senior designer and manufacturing manager, respectively.

#### **4.5.3. Steel Construction/Fabrication Phase**

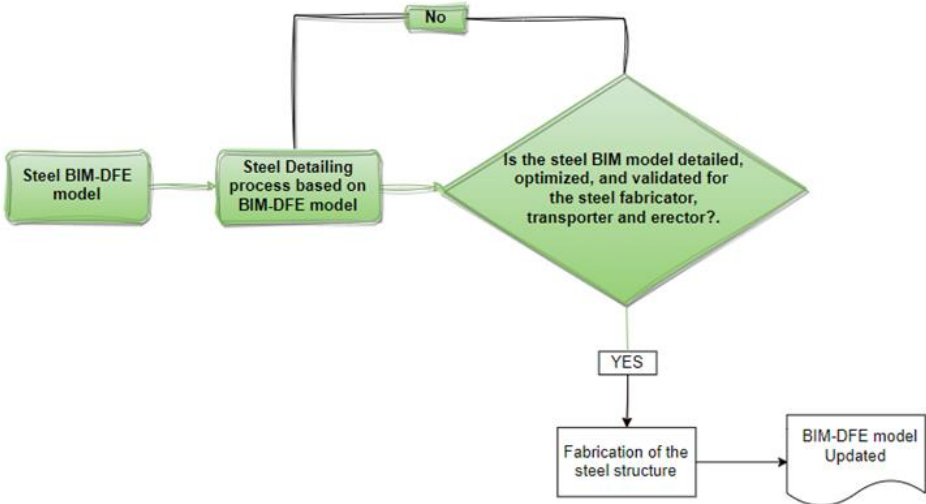
After the design and analysis processes were completed, a 3D BIM of the steel structure was obtained. This model contained detailed information on the geometry, loads, and properties of the structural components, making it an accurate virtual representation of the actual structure. The model also contained information on the construction sequence and manufacturing phases for their efficient planning.

The steel BIM was enriched with additional information, such as the manufacturer and supplier information, material specifications, and data on the manufacturing equipment used. Integrating this information into the BIM facilitates a higher level of collaboration between engineers and fabricators, resulting in a more efficient and accurate structure.

In summary, the 3D BIM-DFE model of the steel structure provides a detailed representation of the structure and the required fabrication processes. This information is essential to begin the next phase of manufacturing and ensure an efficient and accurate building process.

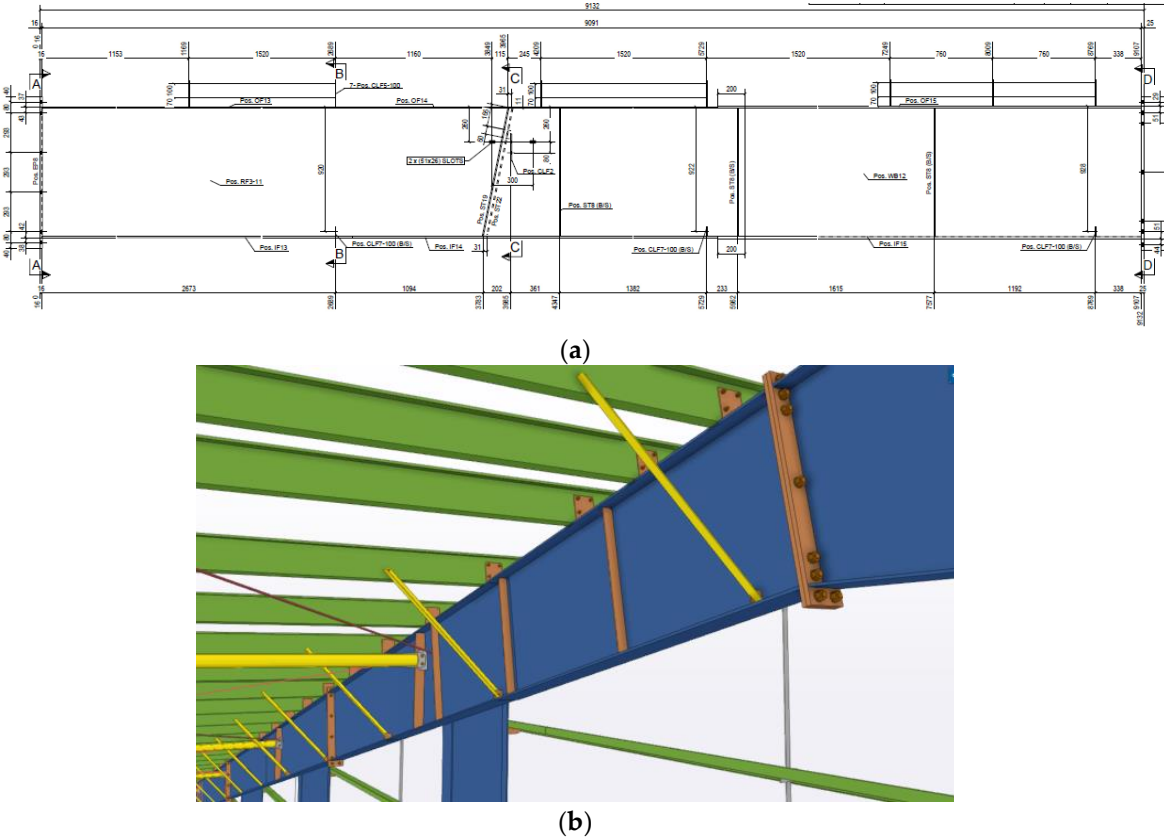
### Steel Detailing Using the BIM Model for Case Study 2

In the fabrication phase, the BIM-DFE methodology establishes guidelines for starting the fabrication process with the steel BIM-DFE from the previous phase, as shown in Figure 39. This BIM has an LOD 400, which is rich in engineering information, prioritization, and fabrication phases. This allows the model to guide the fabrication process to ensure that the technical specifications and structural design requirements are satisfied.



**Figure 39.** Fabrication phase for case study 2.

The steel-detailing process generates the plans for the production of the structural components. Performed using specialized Tekla software, it generates detailed information on structural components such as cuts, perforations, and welds, and extracts dimensions automatically generated by the Tekla model based on information from the previous design phase, Figure 40.



**Figure 40.** Steel-detailing samples (case study 2): (a) 2D beam sample and (b) 3D beam sample

According to the BIM-DFE methodology, the steel-detailing process must be validated by the fabricator, transporter, and erector. As transportation and erection are beyond the scope



of this study, only validation by the fabricator was considered in this engineering stage. However, the BIM-DFE model can be applied to transportation and construction.

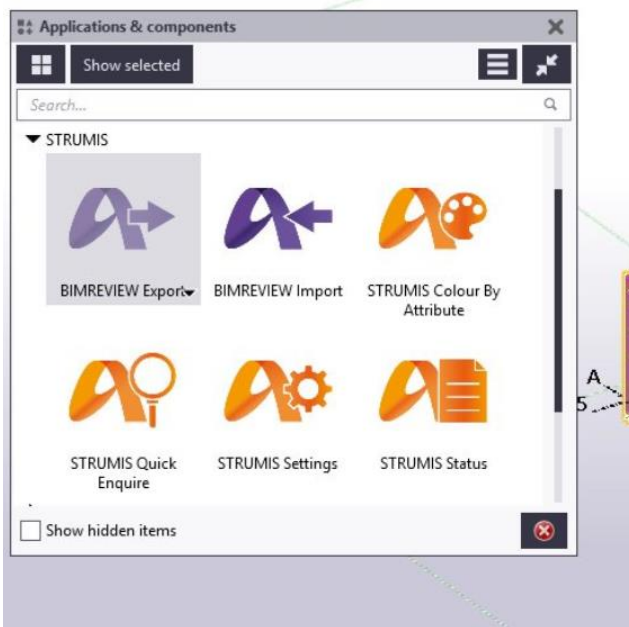
In summary, the fabrication phase began with the steel BIM-DFE model, which served as a guide in the first stage of fabrication and ensured that the technical specifications and structural design requirements were met. The steel-detailing process was then conducted to generate the plans for the materialization of the structural components.

#### Fabrication of the Steel Structure

After the steel-detailing process was completed, the information was transmitted to the factory using the CNC numerical files and planimetry extracted from the detailed model. This information transfer allowed the materialization of the structural components in the factory, which increased the efficiency of the manufacturing process. In addition, nesting of the raw materials was achieved by connecting the Tekla model and MERP STRUMIS. In the fabrication phase, the STRUMIS shop-floor management software was used to plan and monitor the production process of the structural components. The Tekla extension called STRUMIS Integrator was used, which allows the direct transfer of structural information from Tekla to STRUMIS for factory production planning and management (Figure 41a,b).

| En Inv.                             | Retenid                  | Cortes a realizar | Una marca | Marca | Elemento de Planos | Lote   | Fase              | Acabados de   | Cort                     | Estación de               |
|-------------------------------------|--------------------------|-------------------|-----------|-------|--------------------|--------|-------------------|---------------|--------------------------|---------------------------|
| Tipo de HEA HE240A-5235JRG2         |                          |                   |           |       |                    |        |                   |               |                          |                           |
| <input checked="" type="checkbox"/> | <input type="checkbox"/> | 1 @ 12000mm       | Residuo   | 509mm | Resto              | 0mm    | Lote IPE + Placas | Plan de corte |                          | 13636                     |
|                                     | <input type="checkbox"/> | 1 @ 7529mm        | C3        | Pr8   | C3                 | Lote 1 | Oficinas          | GALV          | <input type="checkbox"/> |                           |
|                                     | <input type="checkbox"/> | 1 @ 4039mm        | A117      | Pr53  | A117               | Lote 1 | Oficinas          | GALV          | <input type="checkbox"/> |                           |
|                                     |                          |                   |           |       |                    |        |                   |               |                          | Resto: 0mm Residuo: 509mm |
|                                     |                          |                   |           |       |                    |        |                   |               |                          |                           |
| <input checked="" type="checkbox"/> | <input type="checkbox"/> | 1 @ 12000mm       | Residuo   | 509mm | Resto              | 0mm    | Lote IPE + Placas | Plan de corte |                          | 13637                     |
|                                     | <input type="checkbox"/> | 1 @ 7529mm        | B115      | Pr52  | B115               | Lote 1 | Oficinas          | GALV          | <input type="checkbox"/> |                           |
|                                     | <input type="checkbox"/> | 1 @ 4039mm        | C7        | Pr33  | C7                 | Lote 1 | Oficinas          | GALV          | <input type="checkbox"/> |                           |
|                                     |                          |                   |           |       |                    |        |                   |               |                          | Resto: 0mm Residuo: 509mm |
|                                     |                          |                   |           |       |                    |        |                   |               |                          |                           |
| <input checked="" type="checkbox"/> | <input type="checkbox"/> | 1 @ 12000mm       | Residuo   | 509mm | Resto              | 0mm    | Lote IPE + Placas | Plan de corte |                          | 13638                     |
|                                     | <input type="checkbox"/> | 1 @ 7529mm        | C6        | Pr32  | C6                 | Lote 1 | Oficinas          | GALV          | <input type="checkbox"/> |                           |
|                                     | <input type="checkbox"/> | 1 @ 4039mm        | C9        | Pr10  | C9                 | Lote 1 | Oficinas          | GALV          | <input type="checkbox"/> |                           |

(a)



(b)

**Figure 41.** a) Nesting process and (b) Tekla STRUMIS information transfer.

The information transferred included the geometry, location, part numbers, quantities, cuts, holes, welds, and other manufacturing details. The STRUMIS Integrator extension also provided feedback from STRUMIS to Tekla to enable the verification and correction of errors in the detailed model.

This information transfer between Tekla and STRUMIS ensured the accuracy and efficiency of the production process and reduced the production time. Moreover, the integration of Tekla and STRUMIS improved the control and monitoring of the production process and reduced errors in the fabrication of structural components.

#### BIM-DFE Update

During the fabrication process, all the information was shared with the client using the Trimble Connect web-based platform. The Tekla model and information generated during the steel-detailing phase were shared through Trimble Connect. Production, scheduling, and quality control information was shared from STRUMIS through Trimble Connect. Trimble Connect was also used for the real-time collaboration and information exchange between various project participants. Other software options, such as PowerFab or Steel Project, can also be used to share information in the fabrication process.

For the manufacturing process in case study 2, the same team and planning process were used as in case study 1. Engineer 2 worked a total of 2.5 h owing to the automated information transfer from Tekla to STRUMIS, which took 1 h. Nesting generation required 1.5 h to achieve an efficient cutting process. The material preparation rate was maintained at 2.5 h/ton, similar to that in case study 1.

For the assembly and welding subprocess, the production rate of 7 h/ton optimized the completion time of the manufacturing process. For the entire manufacturing process, the operators had access to tablets that allowed them to clarify any doubts related to the process. Finally, the painting subprocess had a production rate of 0.4 h/ton, which allowed uniform and high-quality paint application. The entire manufacturing process was monitored and

shared with the client through Tekla, STRUMIS, and Trimble Connect. These facilitated the fluid and transparent communication between all parties involved, leading to efficient management of the manufacturing process and delivery of a high-quality final product.

#### **4.6 Results.**

This section presents the results of the productivity indicator analyses for both case studies. Specifically, the productivity indicators are summarized with a focus on the planning and design phases for case studies 1 and 2. The productivity indicator in the fabrication phase was examined using the classic productivity indicator of hours per ton produced, which is commonly used in the industry (Leon et al., 2018).

##### **4.6.1. Case Study 1**

The results of case study 1 are presented. The planning phase (Table 14) includes the subprocess “Preliminary CAD Drawings for Estimation”, where only the professionals participated. The design phase (Table 15), where only the senior and junior design professionals participated, includes the following subprocesses: “Enter Analytical Information into the BIM Engineering Software”, “Preliminary 2D Drawings”, “Client Approval”, “Steel Connection Design”, and “2D CAD Drawings”. Finally, in the fabrication phase (Table 16), professionals participated, such as operators. The subprocesses in this phase include “Production Planning”, “Nesting”, “Material Preparation”, “Assembly and Welding”, and “Painting”.

**Table 14.** Planning phase.

| <b>Project 1: Planning Phase</b> |                  |              |
|----------------------------------|------------------|--------------|
| Subprocesses                     | Team Member      | Hours Worked |
| Preliminary CAD Drawings         | Project Manager  | 60           |
| for Estimation                   | Senior Draftsman | 80           |

**Table 15.** Design phase.

| <b>Project 1: Design Phase</b>                                 |                  |              |
|--|------------------|--------------|
| Subprocesses   | Team Member      | Hours Worked |
| Enter Analytical Information into the BIM Engineering Software | Senior Engineer  | 80           |
| Preliminary 2D Drawings  | Senior Draftsman | 60           |
|  | Junior Draftsman | 40           |
| Client Approval  | Engineer         | 45           |
|  | Draftsman        | 35           |
| Steel Connection Design  | Senior Engineer  | 40           |
|  | Senior Draftsman | 50           |
|  | Junior Draftsman | 40           |
| 2D CAD Drawing   | Senior Draftsman | 30           |
|  | Junior Draftsman | 30           |

**Table 16.** Fabrication phase.

| <b>Project 1: Fabrication Phase</b> |                   |              |            |
|-------------------------------------|-------------------|--------------|------------|
| Subprocesses                        | Team Member       | Hours Worked | Hours/Tons |
| Production Planning                 | Engineer Number 2 | 40           | -          |
| Nesting                             | Engineer Number 2 | 20           | -          |
| Material Preparation                | Operators         | -            | 2.5        |
| Assembly and Welding                | Operators         | -            | 9.5        |
| Painting                            | Operators         | -            | 0.5        |

In case study 1, the average time of fabrication subprocesses such as material preparation, assembly and welding, and painting was 12.5 h/ton. This metric provides valuable insights into the time required for these specific fabrication activities per ton of material in the examined project.

#### **4.6.2. Case Study 2**

In case study 2, the same phases were considered as in the first case, but with notable differences in the results and subprocesses. This was attributed to the interoperability, automation, and optimization of the different models in each phase. In the planning phase (Table 17), the “BIM Estimation” and “BIM-DFE Act” subprocesses required only the participation professionals in the project team. In the design phase (Table 18), the subprocesses “Enter Analytical Information into the BIM-DFE”, “Optimization of the Steel Model Process”, and “Steel Connection Design and Phase Identification Process” required the participation of only the professionals with extensive experience. In the fabrication phase (Table 19), the subprocesses were the same as those in the first case, but with a significant difference in productivity owing to the interoperability between the previous phases and the technology used in this phase.

**Table 17.** Planning phase.

| <b>Project 2: Planning Phase</b> |                    |                     |
|----------------------------------|--------------------|---------------------|
| <b>Subprocesses</b>              | <b>Team Member</b> | <b>Hours Worked</b> |
| BIM                              | Senior Engineer    | 40                  |
| BIM-DFE Act.                     | Senior Engineer    | 40                  |

**Table 18.** Design phase.

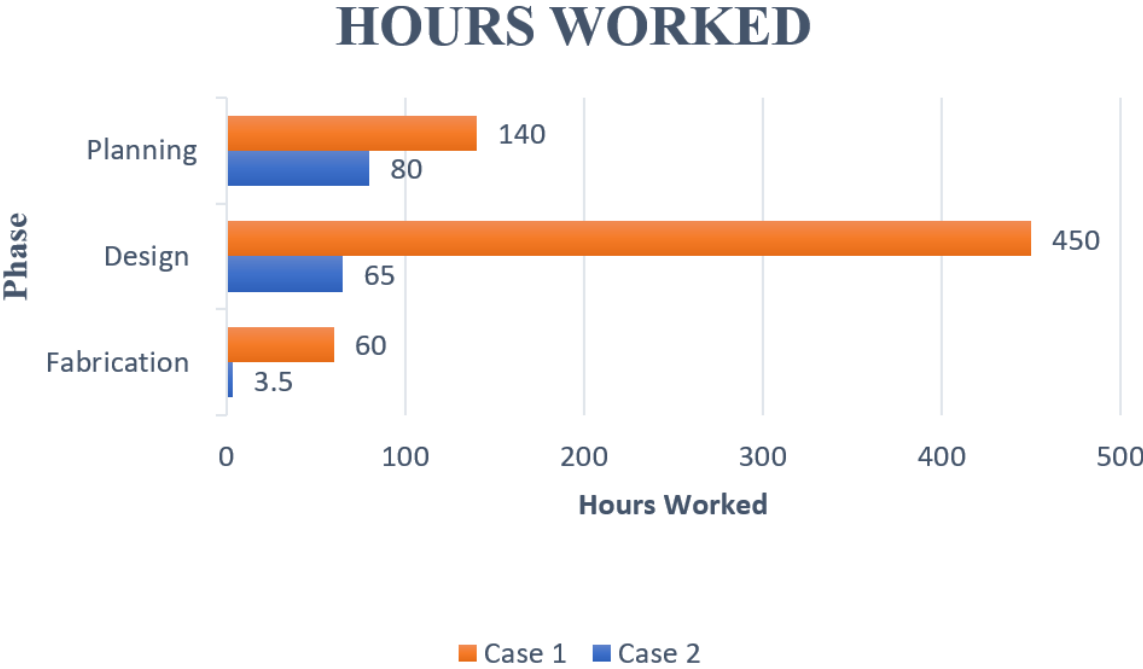
| <b>Project 2: Design Phase</b>                           |                                 |                     |
|--|---------------------------------|---------------------|
| <b>Subprocesses</b>                                      | <b>Team Member</b>              | <b>Hours Worked</b> |
| Enter Analytical Information Into the BIM-DFE            | Engineer/Project Manager        | 20                  |
| Optimization of the Steel Model Process                  | Engineer/Project Manager        | 12                  |
|  | Senior Manufacturing Manager    | 8                   |
| Steel Connection Design and Phase Identification Process | Senior Engineer/Project Manager | 10                  |
|  | Head of Manufacturing           | 15                  |

**Table 19.** Fabrication phase.

| <b>Project 2: Fabrication Phase</b> |                    |                     |                  |
|-------------------------------------|--------------------|---------------------|------------------|
| <b>Subprocesses</b>                 | <b>Team Member</b> | <b>Hours Worked</b> | <b>Hours/ton</b> |
| Production Planning                 | Engineer Number 2  | 1                   | -                |
| Nesting                             | Engineer Number 3  | 2,5                 | -                |
| Material Preparation                | Operators          | -                   | 2.5              |
| Assembly and Welding                | Operators          | -                   | 7                |
| Painting                            | Operators          | -                   | 0.4              |

In case study 2, the average fabrication time was 9.9 h/ton of material. This result provides specific insights into the time required for tasks such as material preparation, assembly and welding, and painting.

Although the sizes of the studied projects vary, the project typology, steel connections, and complexity are similar. The relevant indicators in this study are the planning, design, and fabrication phases, while transportation and erection were excluded. Figure 42 shows a comparison of the total hours worked in case studies 1 and 2 (engineers and draftsmen). The graph presents the number of hours worked by each professional in the planning, design, and fabrication phases of the project. The total hours worked in case study 2 are significantly lower than those in case study 1.



**Figure 42.** Summary of hours by phases.



Figure 43 shows a bar graph summarizing the number of hours worked per ton in case studies 1 and 2.



**Figure 43.** Summary of fabrication hours/ton.

#### 4.7. Discussion and conclusion.

Considering that the investigations presented in this PhD thesis are complementary to each other, the discussions and conclusions have been grouped in chapter 5 and 6 respectively.

# CHAPTER 5

## Discussion of the results

The present chapter discusses the results obtained from each of the research questions of this PhD thesis.

### 5.1 Research Question Q1

What are the use cases of BIM in steel building projects?

The bibliographic review was analyzed and grouped into three sections: 1. Project collaboration: Geometric Semantic; 2. Transfer information, visualization API, AR, VR; and 3. Management, Sustainable, and Site Organization. This discussion section includes observations of the BIM uses (BU)

BIM utilization descriptions:

*Use of 3D BIM in collaborative steel building projects: Geometric and semantic.*

BU#1: One of the main applications of this BIM use is the visualization and improvement of steel processes. This has been the focus of literature to date (An et al., 2020; Case et al., 2014; S. Chen et al., 2020; Xie et al., 2017; M. Yoo & Ham, 2020), highlighting 3D BIM as a comprehensive project engine that will replace 2D drawings with a communication channel that principally works through a 3D model (Shin, 2017; Stojanovska-Georgievska et al., 2022). The visualization and comprehension benefits of 3D BIM models can be used by people fulfilling various roles in the steel building process, such as owners, welders in the

factory, and workers installing structural bolts during the erection stage (Laefer & Truong-Hong, 2017). Conversely, the exclusion of BIM can impact the level of understanding and stakeholder expectations of the project (Xie et al., 2017). Should a 3D BIM model be executed only in certain phases of a project, these phases alone will benefit from the visualization and comprehension provided by the 3D model (Erfurth, 2019). Furthermore, excluding this BIM use from steel construction will prevent detection of interferences with other mechanical engineering and plumbing MEP disciplines (M. Yoo & Ham, 2020). BIM use applies to the planning, design, manufacturing, construction planning, and erection phases. This use is not applicable to the transportation phase.

BU#2: From a structural engineering perspective, BIM collaboration in structural engineering, and level of detail (L.O.D), permits interoperability and aims to maximize building model information collaboration to improve work efficiency and structural quality (Shin, 2017). To implement this, the level of information detail that will be transferred between the different stakeholders must initially be agreed upon (Tian et al., 2021). The literature review showed that this utilization was not applied in three of the six building project construction phases: planning, transport, and erection phases were excluded. For example, by not applying this utilization in the planning phase, it would be impossible to determine the steel tonnage to be processed by the manufacturer and assembler, which is essential information for a correct estimate of the project costs by stakeholders, especially the owner (Barg et al., 2018). In addition, a lack of guidelines that clearly state the L.O.D required in the BIM models for the erection stage could result in misunderstandings and delays.

BU#3: The early integration between design, manufacture, and assembly, based on BIM models, is a critical utilization in this section, although there is no evidence of it in the transportation process. It is evident from this literature review that the incorporation of BIM models to ensure early integration between the designer, manufacturer, and erector reduces the cost and time of steel building projects (Barg et al., 2018; Bartenbach et al., 2019a; Malik et al., 2019; Shahtaheri et al., 2017; Wei et al., 2014; Zhu et al., 2021). This ensures that the resources available to the fabricator and erector are considered in the design process (Barg et al., 2018). In addition, the stakeholder is encouraged to work toward a common, and not an individual, objective (Soh et al., 2022; W. C. Wang et al., 2014; W. S. Yoo et al., 2012). Conversely, insufficient information is available to show the beneficial effects of early integration in the transport phase.

BU#4: The creation of BIM models before manufacturing positively impacts the following phases of transportation, planning for construction, and erection. Before manufacturing, the utilization of BIM models primarily takes advantage of the ability of BIM to detail steel structures and automatically generate the 2D drawings required for fabrication (Barg et al., 2018; S. Chen et al., 2020; Wei et al., 2014). In addition, the steel detailing software can transfer information from the BIM model to the factory's computer numerical control machinery to optimize cutting, bending, and punching (Malik et al., 2019). The exclusion of BIM from the stages preceding fabrication results in delays and a lack of accuracy in the documentation necessary for manufacturing, as these processes are done manually by a draftsman, rather than by BIM software algorithms (Costin et al., 2021a; Soh et al., 2022). The 3D BIM model increases the reliability and precision of the results, or deliverables, of each phase of the project.

BU#5: The traceability of the manufacture and assembly processes using BIM models is primarily utilized in the design, manufacture, and erection processes. Similar to the previous BIM utilization (BU#4), the BIM model includes detailing software rich in information with graphical and non-graphical examples of the primary and secondary steel elements (Bartenbach et al., 2019). This information is transferred to the Enterprise Resource Planning (ERP) software to implement production control and can be directed to a common data environment to share the manufacturing or assembly statuses with the stakeholders (Tavares et al., 2019). The exclusion of BIM utilization necessitates the manual input of information for fabrication control and assembly, which decelerates the process and exposes it to greater errors because of human interactions and the transfer of information (Tavares et al., 2019).

*Utilization of BIM information in steel building projects: Transfer information, visualization API, AR, and VR.*

This group of BIM uses facilitates communication and comprehension for defining deliverables, stakeholder decisions, and the coordination between phases and construction professionals. However, the absence of this group of BIM uses in the planning and transportation phases can generate errors in defining the product (building) and a lack of coordination or control between the manufacturing, transportation, and assembly phases.

BU#6: BIM and virtual/augmented reality are notable developments in this section. Combining BIM models with augmented and virtual realities improves the comprehension of stakeholders, such as owners and investors, who are unfamiliar with construction language (Ding et al., 2019a; Tavares et al., 2019). It has also been incorporated into manufacturing to check the quality of steel components, such as welds and holes, and simulate complex assemblies. This BIM utilization is present in all phases, except planning and transportation.

BU#7: IoT is one of the rarest, but most disruptive, utilization of BIM. The primary purpose of this utilization is to optimize steel construction information by applying data-driven methods and analytics to perform real-time collaborative management, and control of steel elements, manufacturing, and assembly activities (Tang et al., 2019). The information obtained from IoT tags and sensors is fed into a centralized database where the average performance of steel activities can be recorded (Scianna et al., 2022; Tang et al., 2019). This information allows for faster decision making when deviations or project reorganizations occur. Notably, this utilization is found in the design, fabrication, and erection phases.

BU#8: An API is used for non-geometric information transfer. Programming interfaces (APIs) are useful links that run plugins between the different software involved in the design and manufacturing processes to customize interoperability between BIM models (Jeong et al., 2016). In addition, it saves time for repetitive tasks within known scenarios related to design (Jeong et al., 2016; Malik et al., 2019), and it can be programmed to exchange information from the BIM model to the design phase and ERP. This is possible as long as the BIM and ERP software have open API. This BIM utilization occurs primarily in the design and fabrication phases.

BU#9: Controlled installation through BIM is used to monitor and control the erection of steel structures based on the BIM model. One of the main objectives of this utilization is to report, in real-time, the status of the fabrication items, such as painting, welding, assembly, and dispatch, to the stakeholders, and the erector contractor, in particular (Tian et al., 2021; M. Yoo et al., 2019). This utilization is present only in the construction planning and erection phases.

BU#10: BIM and laser scanning data: the main characteristic of this utilization in steel construction is the development of a BIM model from real survey data of existing project conditions by importing the information through a point cloud (Mischo et al., 2019; Oti & Tizani, 2015), which is specially oriented to isostructural development. This information, obtained by a laser scanner, can also be used to prepare complex assemblies and resolve interferences with other specialties (M. K. Kim et al., 2016; Yang et al., 2020). This utilization is mainly found in the design, fabrication, and erection phases.

*Use of BIM in Steel Project Management, Sustainable, and Site Organization*

This group of BIM uses facilitates project management at a tactical and operational level in each phase. In addition, it is used to incorporate the concepts of sustainability and infrastructure management.

BU#11: Cost analysis using BIM models is one of the largest uses in this segment. The particularity of this use is the addition of non-graphical information to the BIM model, which permits the calculation of the costs of each steel element (AbouHamad & Abu-Hamd, 2019; Barg et al., 2018; Shahtaheri et al., 2017). With this use, it is possible to segment the costs according to the type of steel structure (light, heavy, or extra heavy), which allows the total project costs to be predicted with greater certainty (Nekouvaght Tak et al., 2020; Yu et al., 2021). This use appeared in all phases except for transport.

BU#12: BIM for construction management is one of the largest uses of BIM in different steel building processes. Here, BIM is used for the different stages of the project, from the quantification of materials to managing person-hours in the field (Navaratnam et al., 2022; Oti & Tizani, 2015). In addition, it allows the reporting of information to estimate possible

deviations of the project from an economic perspective (W. C. Wang et al., 2014). This use was observed in all phases, except for transport.

BU# 13: Structural health monitoring with BIM models permits automated data and damage visualization module to be created, through which sensor data are interpreted to identify damage or anomalies in the steel structure, and the affected building components are highlighted and labeled in the 3D BIM model (Zhang & Bai, 2015). To facilitate the display, damaged or nearly damaged module elements are highlighted in the BIM model through color coding, based on deformation threshold values to be considered by the designer, and facilitates making decisions. This applies to new projects in the development phase and reusable structures in the remodeling phase. This purpose was displayed in the manufacturing and erection phases.

BU# 14: BIM information to improve site logistics planning: the use of BIM stands out as a coordination engine to improve construction planning, considering methodologies, such as just in time, to optimize the limited spaces in the field model (L. K. Chen et al., 2021; Costin et al., 202), especially for projects that are conducted in urban areas where the collection space material is limited. With this use, it is possible to simulate different scenarios in the BIM model to reach the best decisions according to the project's needs (Asgari Siahboomy et al., 2021; Bortolini et al., 2019). This use occurs mainly in the transportation, construction planning, and erection phases.

BU#15: BIM is used for de-constructability and the identification of reusable steel materials in remodeling stages, thus allowing the BIM model to identify potential structural elements that can be reused, which decreases project costs and benefits the total cost of the project (Akanbi et al., 2018; Ness et al., 2015). Existing elements can be modeled with a laser



scanner, as shown using BU#10 and structure verification using BU#13. However, with this use, it is possible with the same models to optimize the planning of deconstruction according to the characteristics of the project (Basta et al., 2020). This use is presented in the first three phases of a steel project: planning, design, and fabrication.

The BIM uses found do not exhibit continuity throughout the phases of the steel construction project; hence, their benefits are truncated. In other cases, they are developed in the late phases or specifically within a phase. The aforementioned discussion serves as evidence that BIM has been unable to break the fragmentation of the steel construction industry. Therefore, there is a need to investigate, develop, and propose BIM uses that generate continuous communication, coordination, and management between phases and assure deliverables that conclude with a building that meets the requirements established at the beginning of the project.

Table 20 presents the findings of the systematic literature review regarding BIM uses and the software tools in steel buildings; the table shows the bibliographic sources used to summarize each BIM utilization. The studied cases indicated a wide variety of tools used in the steel building process and also revealed how information is exchanged between the tools (IFC format); however, certain trends in the tools used were identified. The prevailing BIM tool is Tekla, which appears in 13 of the 15 BIM applications. Other software tools with more than one use were Revit, Naviswork, MicroStation, and ArchiCAD.

**Table 20.** BIM uses in application phase and bibliographic resources. (Avendaño et al., 2022)

| <b>BIM Utilization</b>   | <b>BIM use in Application Phase</b>  | <b>3D Software Tools</b>  |
|--|--|---|
| 3D BIM models to visualize and improve steel processes.                                      | <i>Planning, design, fabrication, and planning for construction.</i>           | Tekla, Navisworks, Revit, ArchiCAD, SketchUp.                         |
| BIM Collaboration for Structural Engineering and L.O.D.                                      | <i>Design, fabrication, and planning for construction.</i>                     | Tekla, Revit, MicroStation.   |
| Early integration between design, manufacture, and assembly based on BIM models.             | <i>Planning, design, fabrication, planning for construction, and erection.</i> | Tekla, Navisworks, Revit, MicroStation.                               |
| Create a BIM modeling before fabrication.  | <i>Design and fabrication.</i>   | Tekla, Revit.   |
| Quality control and traceability of the manufacture and assembly processes using BIM models. | <i>Design, fabrication, and erection.</i>                                      | SolidWorks, Revit, Tekla.   |
| BIM and virtual/augmented reality  | <i>Design, fabrication, and planning for construction erection.</i>            | Revit, Tekla.   |
| BIM and IoT  | <i>Design, fabrication, and erection.</i>                                      | Revit, Tekla.   |
| Use API for non-geometric information transfer.  | <i>Design and fabrication.</i>   | Revit, Navisworks.  |
| Control installation through BIM.  | <i>Fabrication, planning for construction, and erection.</i>                   | Revit, Navisworks, Tekla, MicroStation                                |
| BIM and Laser scanning data.   | <i>Design, fabrication, and erection.</i>                                      | Revit, Tekla, AECOSim, FARO SCENE.                                    |
| Cost analysis through BIM models.  | <i>Planning, design, and fabrication, planning for construction.</i>           | Tekla, MASTAN2, STAAD Pro, SAP2000, Revit.                            |
| BIM for construction management.   | <i>Planning, design, and fabrication, planning for construction.</i>           | Revit, Civil 3D, MS Projet, Navisworks, Tekla, ArchiCAD, Synchro Pro. |
| Structural health monitoring with BIM models.  | <i>Design and erection.</i>  | Revit, Tekla, ArchiCAD.   |
| BIM information to improve site logistics planning.  | <i>Transport, planning for construction, and erection.</i>                     | Revit, Tekla, Synchro Pro, MicroStation                               |
| BIM for de-constructability and identification of reusable steel materials                   | <i>Planning, design, and fabrication.</i>                                      | Revit, Dynamo.  |

## 5.2 Research Question Q2.

Is it possible to merge the scientific knowledge and the industry experience, in order to create an original BIM integration model to improve the management of steel building projects?

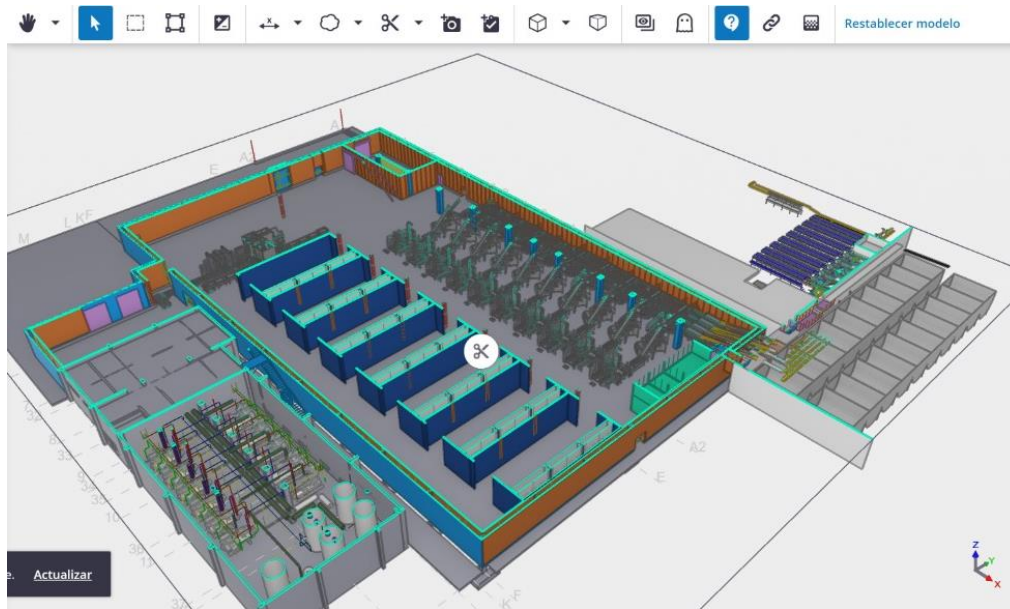
After two rounds of the Delphi questionnaire, a consensus among the experts regarding BIM integration applied to steel construction processes was reached.

As indicated in the scientific literature, the need to conduct an early integration through a BIM model is highlighted among experts in the design phase. This early integration is also recommended to be advanced as a steel BIM estimation model in the planning phase, which allows the determination of the amount of steel tonnage to be processed in the planning phase, and is critical because most stakeholders of steel construction projects provide quotes, estimates, and yields based on the indicated tons to be processed. Knowing the value of the amount of steel to be processed makes it possible to select different steel suppliers in the planning stage. This presents repercussions in applying manufacturer resources in the design phase, transport, and erection, which in turn reduces the quotation and execution time of the steel project.

Another outstanding consensus among the experts is the need to have a project manager who accompanies the owner of the steel project during all phases because this is generally outside the construction industry; the role of the project manager is recommended to be obtained by the design engineer, who will ensure that the level of detail described in the BIM models of each phase is met. Therefore, it is recommended that the status of individual processes in each phase is reported through data in a common real-time environment to enable the monitoring and decision-making based on the current situation of a project.

Herein, the results of this study are interpreted based on the expert agreement level in each main phase to fully understand the integration of BIM usage in the steel building process (BIM-DFE). As a reference to the BIM integration in various processes, B# indicates the BIM usages shown in Table 6. In addition, a real case is presented to graphically illustrate the integration of BIM in the different phases of the steel building projects.

A fish processing plant located in Coronel, Concepción, Chile, was selected as a representative sample to illustrate the findings for research question 2. This project was executed and coordinated by the VVL engineering company (Figure 44). More than 80% of this project involved steel construction work. One of the biggest challenges this project presented was the coordination of different specialties because each specialty was represented with different BIM tools. Trimble Connect software was used to conduct the BIM coordination, in which the BIM models were introduced in the IFC format from different specialties. This allowed for the identification and resolution of collisions during the early stages of the project. In the erection and construction stage, this common data environment helped in understanding the progress of the structure, which was used by the remaining stakeholders for payment purposes against the delivery of the assembled structure.

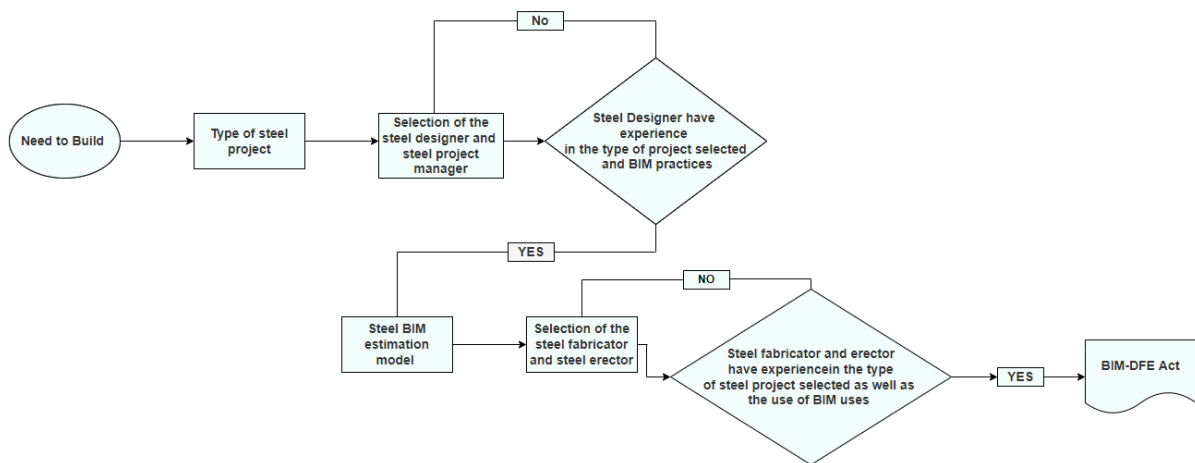


**Figure 44.** Fish processing plant by the VVL engineering company.

*Phase 1: Steel Planning*

The implementation of a BIM model in this early stage was proposed, which in addition to managing the visual expectations of the owner (B1), it provides a preliminary analysis of the costs of the fabrication, transportation, and erection of the steel structure (B11). Thus, the owner can optimize resources, reduce operational costs, and evaluate different alternatives that satisfy construction needs, opting for the most sustainable alternative (Laefer & Truong-Hong, 2017). To achieve this, the application of BIM and augmented reality is proposed to improve the understanding of the decision-makers (M. Wang et al., 2020), especially those unfamiliar with the technical construction terminology (B6). Therefore, the main contribution of BIM in this phase is the visual expectations of the owner. Another target of this phase is to determine the amount of steel required for the project, thus accelerating the quotation response of supplier companies that must be selected in the following process (Barg et al., 2018), such as steel fabricators and erectors (B3).

Figure 45 presents the activities that were agreed upon by the panel of experts regarding the planning stage of a steel construction project, which is required at the beginning of every type of construction project that needs to be built. Depending on this requirement, the type of steel to be used in the project was identified, which can be industrial or commercial. Subsequently, the next sub-process is the selection of the steel designer and project manager, which is a critical step for the success of the project because these professionals will guide the owner during the entire steel construction cycle. The panel of experts concluded that the role of the project manager would ideally be filled by the design engineer; however, it could also be accomplished by another professional with expertise in BIM usage and the type of steel selected for construction in the previous step.

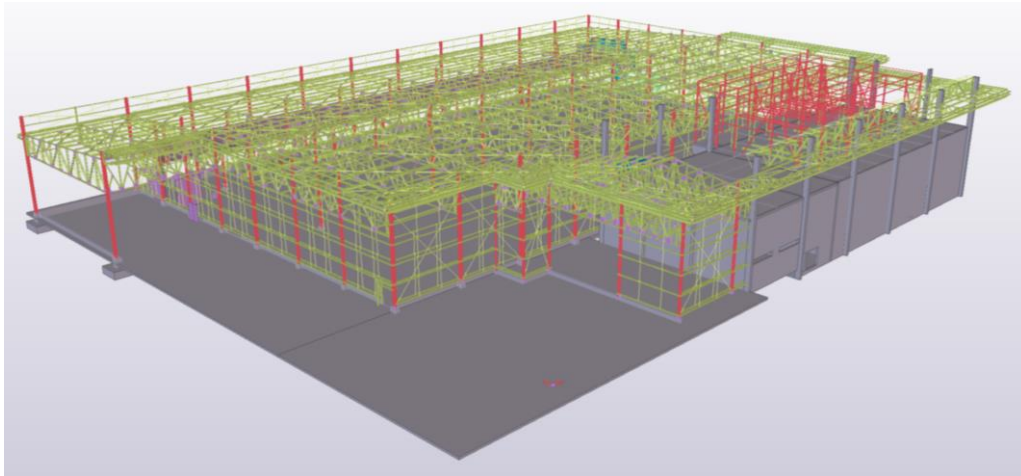


**Figure 45.** Steel BIM planning process.

The selected design company or professional must have experience in the type of steel project selected (industrial or commercial), the use of BIM (Avendaño et al., 2022), and the capabilities necessary to create a preliminary BIM estimation model (Figure 46). This preliminary BIM model can be created using BIM software, such as Tekla, SDS/2, and Advance Steel.

The main objective of this phase is to identify the amount of steel in tons that will be used in the project; therefore, it will accelerate the quotation response of the supplier companies that must be selected in the next sub process, such as steel fabricators and erectors.

This phase ends with the BIM-DFE Act. (3D BIM model, and definitions of the BIM collaboration between the steel designer, steel fabricator, and steel erector), which defines the scope for each specialty, the level of detail for the deliverables of the BIM steel project, and the guidelines for the collaboration and commitment between specialties throughout the steel construction phases.

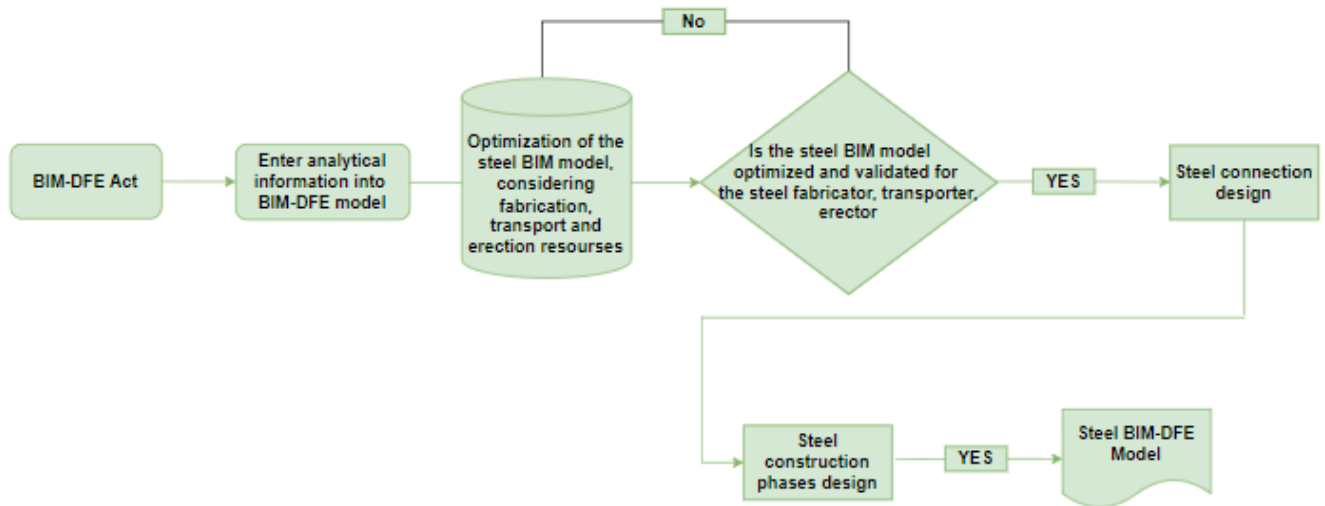


**Figure 46.** BIM estimation model sample.

### *Phase 2: Steel Design*

In this stage, the collaboration and validation between the various groups for materializing a steel-building project are generated. The communication between the client and designers, the designer and fabricator, the designer and erector, and the erector and fabricator, ensures the success of the project (Barg et al., 2018; Erfurth, 2019; Saka & Chan, 2020; W. C. Wang et al., 2014) by reducing time, improving traceability, production control, optimizing

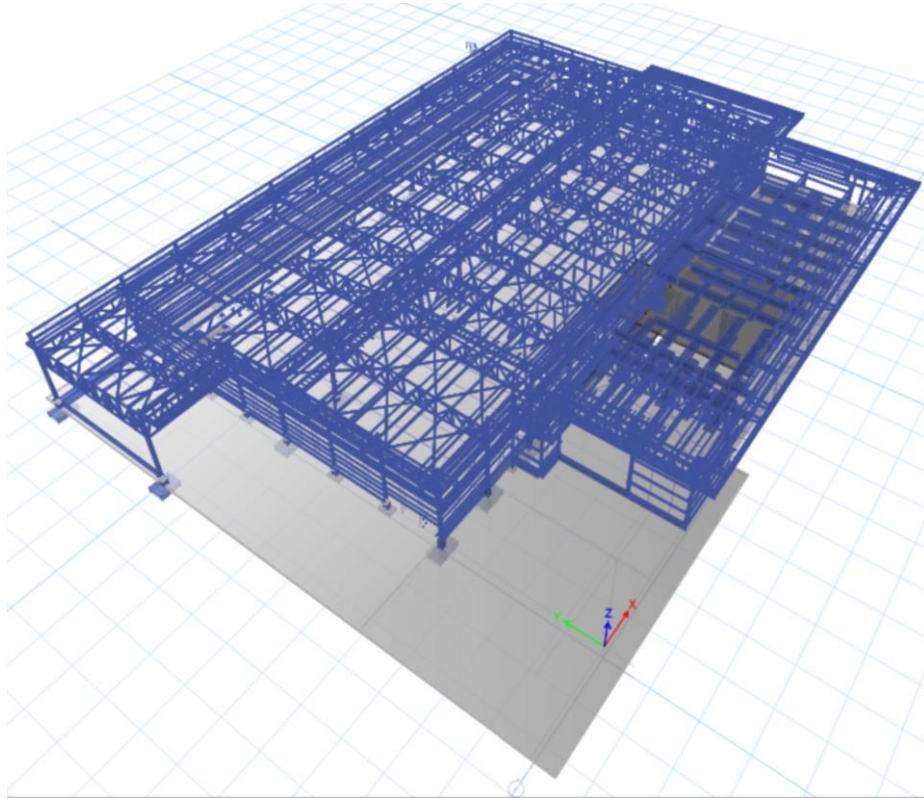
transportation, and assembly of the structure (B3, B11). The main objective of BIM in this phase is to develop a BIM model that incorporates the resources of the manufacturer and assembler that were previously selected in the planning phase to expedite future phases.



**Figure 47.** Design process of BIM-DFE.

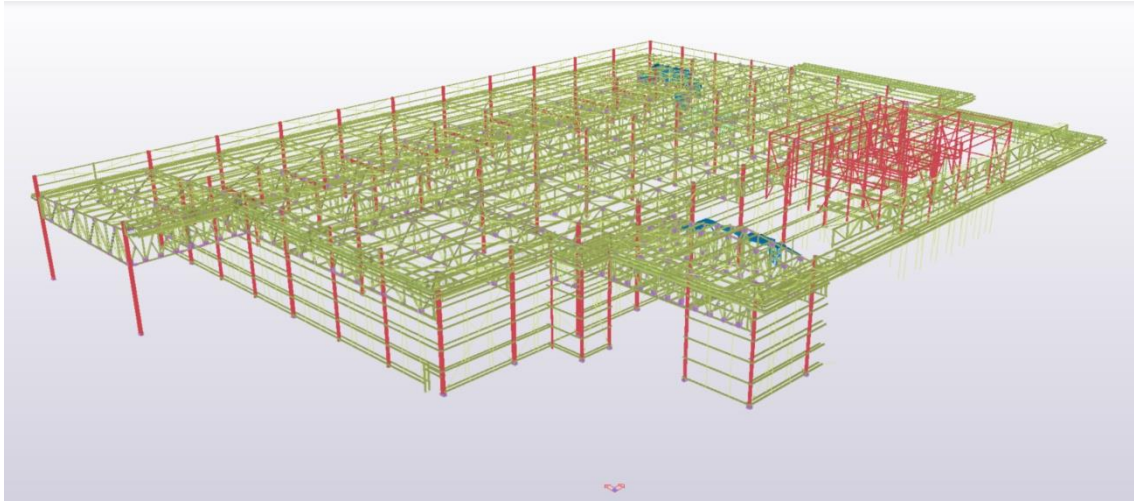
As shown in Figure 47, this process begins with the guidelines of the BIM-DFE act and adds analytical engineering information to the BIM estimation model created in the previous phase. At this stage, the BIM estimation model is exported to a structural calculation software, such as SAP, ETABS, RAM, or the Industry Foundation Classes (IFC) format for a precise analysis, considering the project requests (live loads, dead loads, wind load, snow load, earthquakes, etc.) (An et al., 2020; Barg et al., 2018; Case et al., 2014; Erfurth, 2019; Laefer & Truong-Hong, 2017; Oti & Tizani, 2015; Shahtaheri et al., 2017; Shin, 2017; Tian et al., 2021). Figure 48 presents an example of the ETABS Model.



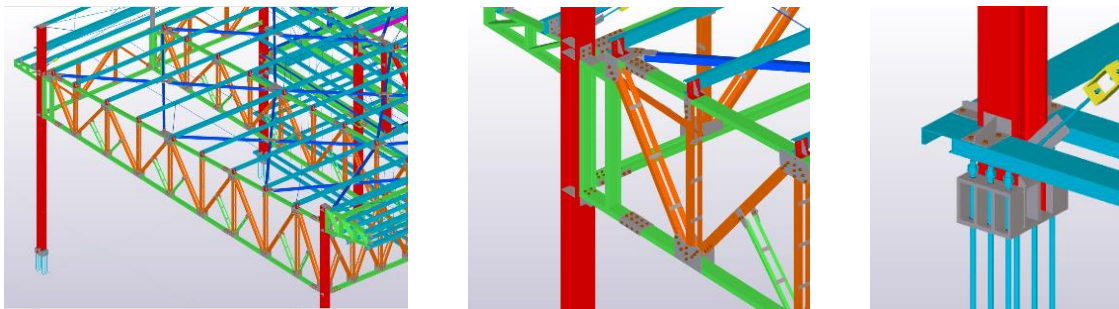


**Figure 48.** ETABS Model LOD 200 sample.

The BIM model is optimized in the following step considering fabrication, transportation, and erection with one of the following specialized software: Tekla, SDS/2, Advance Steel, or a similar software (B1, B3, B11) (Figure 49). At this stage, the resource constraints of the fabricator, transport, and erection of the structure are incorporated into the steel BIM model. Incorporating the fabricator and erector constraints into the engineering design facilitates the flow of production in the fabrication, transportation, and erection processes and provides greater certainty for the entire project; at this stage, the level of detail (LOD) is increased to LOD 400 for a greater efficiency in the transfer of information among all the project stakeholders (Figure 50).



**Figure 49.** Tekla Model—Study sample.



(a)

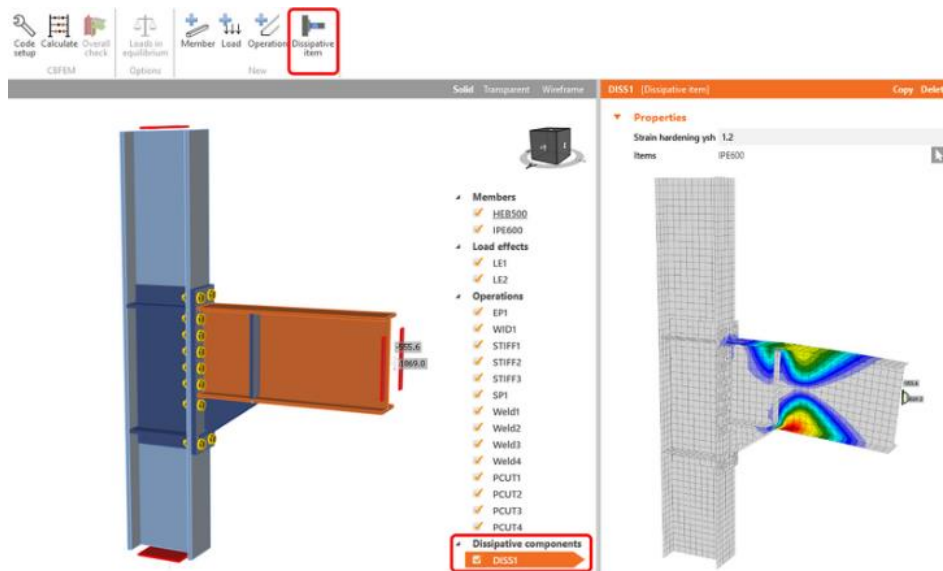
(b)

(c)

**Figure 50.** Steel BIM LOD 400—Study sample. (a) Tekla Model LOD 400, (b) Miscellaneous LOD 400; (c) Steel Column LOD 400.

The information should be shared with the remaining stakeholders through a common data environment, such as Trimble Connect, to enable all stakeholders to comment on and validate the information exposed in the optimization stage of the project. When the BIM model has been validated, the following process of calculating the connections is implemented.

The main problem between the design team and contractors is the inadequate submission of information related to steel connections. Finding a solution to this problem can initiate the improvement of the design process, which is essential for transferring the information the contractors have regarding the project to the design team in an early stage (Soh et al., 2020). At this stage, the connections can be calculated in a calculation software, such as Static Idea, which can be transferred bidirectionally to the BIM model using the IFC format (Figure 51).



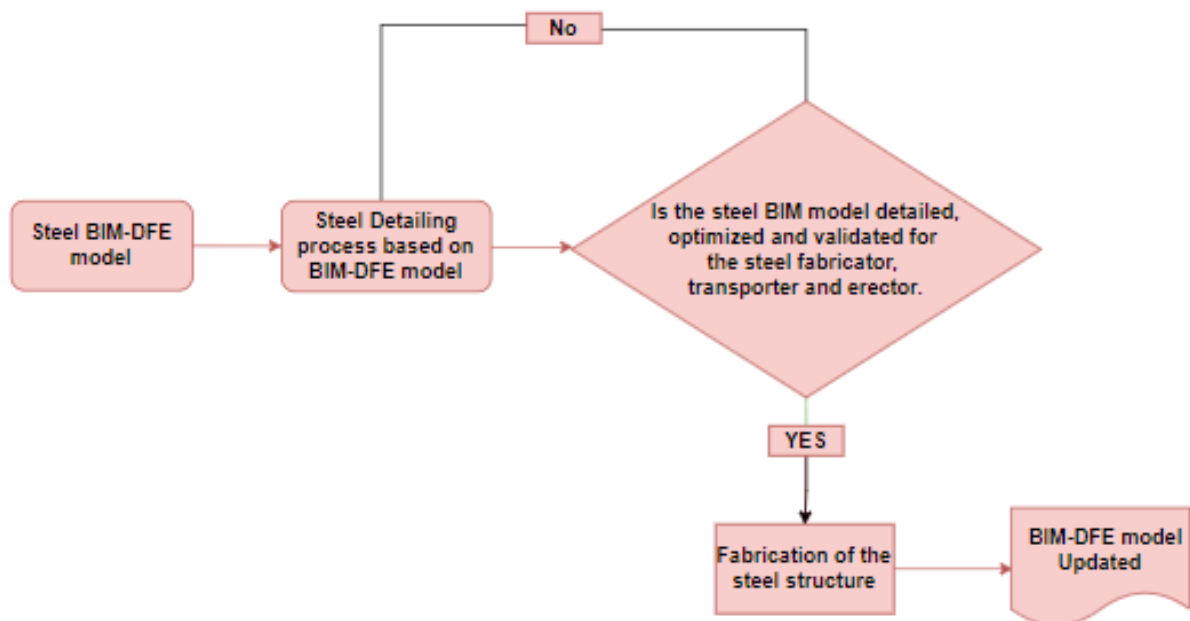
**Figure 51.** Idea Connection software sample.

The following process continues with the design of the steel construction phases led by the designer and validated by the erector and/or contractor (B1, B3, B4, and B14). Similar to the previous stage, this stage aims to validate the steel BIM model, which will be responsible for materializing on-site. The result of the aforementioned activities is a steel BIM-DFE fabrication model. Defining this new steel BIM fabrication model based on structural engineering generates a deliverable framework with a high level of detail, which ensures the

efficient use of resources during fabrication, transport, and erection (Avendaño et al., 2022; Barg et al., 2018; Costin et al., 2021).

### *Phase 3: Fabrication*

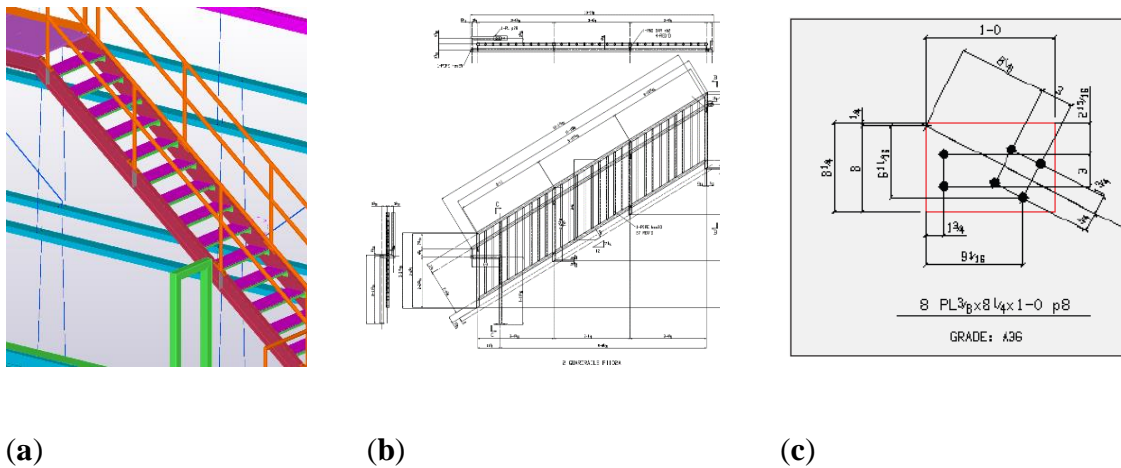
The main objective of this phase is to accelerate the manufacturing processes, given that the project has already considered the manufacturing resources of the previous phases (Figure 22).



**Figure 52.** Fabrication process by BIM-DFE.

This phase begins with the steel BIM-DFE process from the previous phase (Figure 52). Experts agreed that taking advantage of the early integration and LOD 400 conducted in the previous design stage is necessary in this phase, not to add more information to the 3D model. It is possible to begin with the planimetric information extraction from the BIM model to manufacture and generate CNC files for cutting, welding, and perforating the steel elements (An et al., 2020; Barg et al., 2018; S. Chen et al., 2020; Jeong et al., 2016). This can be

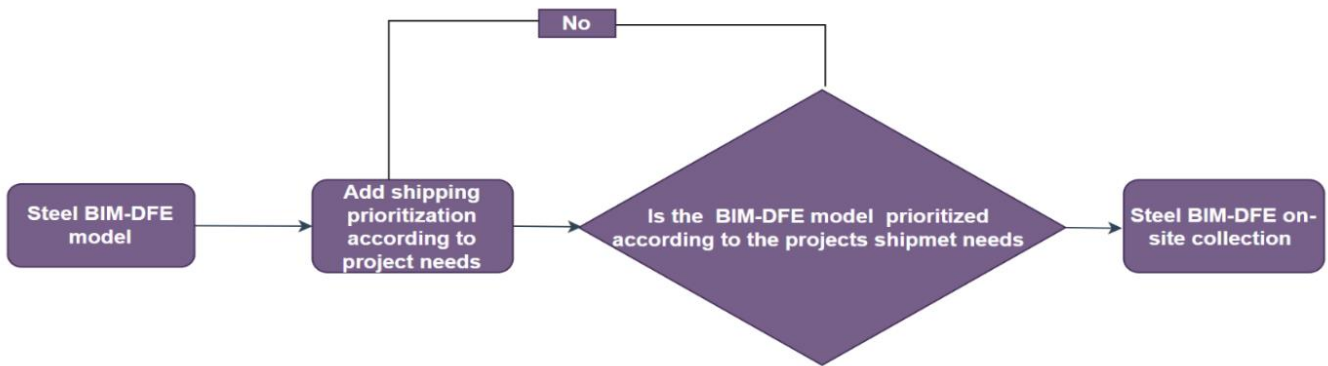
achieved using BIM visualization software, such as the Tekla visualizer. It is also proposed that the manufacturing status be shared by different stakeholders through a common environment, such as Trimble Connect, to publicize the manufacturing status (Figure 53) (B4).



**Figure 53.** Steel BIM Fabrication—Study sample. (a) 1Tekla model LOD 400, (b) Automatic planimetry extraction, (c) CNC extraction.

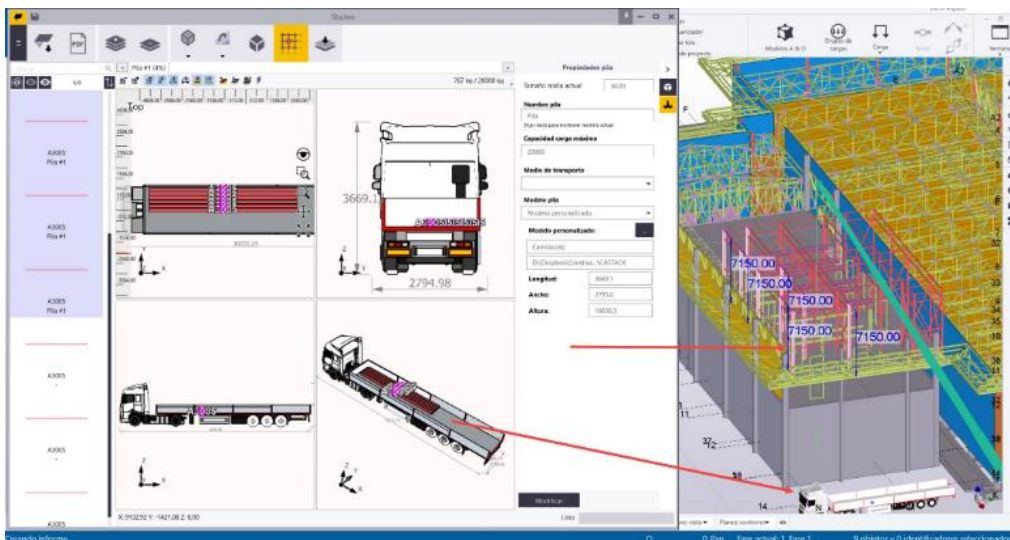
#### *Phase 4: Steel Transportation*

As shown in Figure 54, this phase begins with the BIM model optimized and nurtured from all the previous stages, allowing the carrier to use this information to classify the elements to be transported (B13), conduct a follow-up, and prioritize the shipment according to the needs of the project (L. K. Chen et al., 2021) (B14). The result of this process is sending the material to the work site and always having the information regarding where, how, and when the elements are to be assembled.



**Figure 54.** Transportation by BIM-DFE.

This also has a significant impact on the assembly logistics. A common mistake at this stage was the lack of control over the dispatch of steel elements from the factory to the field. In this phase, the expert agreed to take advantage of the information from the manufacturing BIM model and transfer it through IFC files to the software that generates the use of truck spaces to be sent to the field by using algorithms, such as the Fortosi software. This reduces the number of shipments and alerts the factory of any missing elements to be sent (Figure 55).



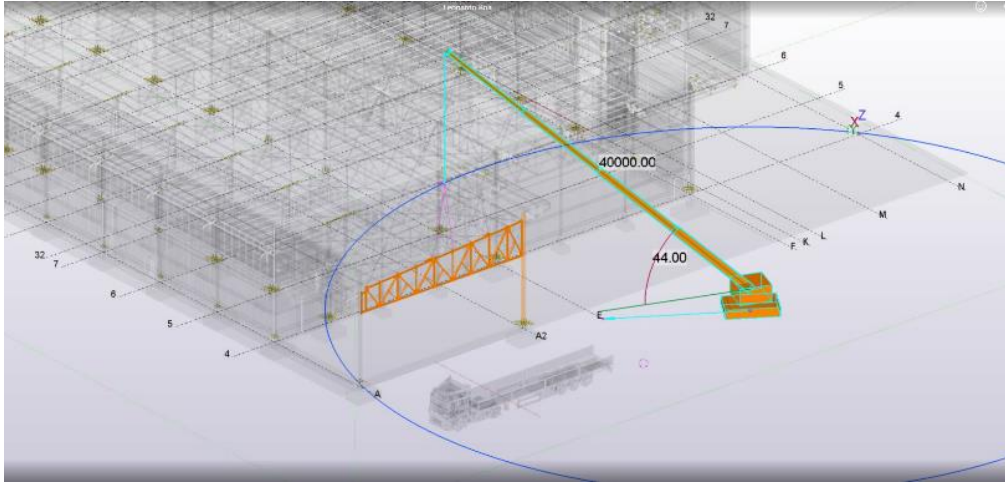
**Figure 55.** Steel BIM truck loading sample.

### *Phase 5: Erection*

As shown in Figure 56, this process begins with the steel BIM on-site collection with significant information from all the previous phases, which allows the planning, budgeting, and adequate supervision of the construction and assembly processes of a steel building site. (BU9) (Figure 57). The steel construction progress phase is displayed in real-time, directly and accurately reflecting the hole construction process (B14). The express process includes sensors in the steel structures that allow the identification of failures caused by transportation or stockpiling to prevent the detection of these failures when the structure is already assembled or worse, in the construction operation stage (Zhang & Bai, 2015). Finally, combining IoT with the common data environment allows the control of the different stages of the steel section. It reports the steel status of the work site to all the specialties to facilitate the coordination in the fabrication process and make the relationship between the rider and client more transparent regarding the supervision and costs of the work performed (B7, B9, B13).



**Figure 56.** BIM-DFE Erection.



**Figure 57.** BIM-DFE-Erection model.

Table 20 presents a summary of the inputs, outputs, stakeholders and BIM models corresponding to the BIM integration process map proposed in this doctoral thesis. Ref: Figures 13, 45, 47, 52, 54, 56.



**Table 21.** Summary of the deliverables of the BIM integration process map by phases.

| <b>Application Phase</b> | <b>Stakeholders</b>                         | <b>BIM Software Tools</b>  | <b>Inputs from the previous phase</b> | <b>Deliverables (Outputs)</b>  |
|--------------------------|---|--|---------------------------------------|--|
| Planning.                | Owner, steel designer.                      | Tekla, SDS/2, Advance Steel.   | -----                                 | Preliminary BIM estimation model.<br>BIM-DFE Act: Definitions of the BIM collaboration between the steel designer, fabricator, erector.  |
| Design.                  | Designer, fabricator, transporter, erector. | SAP, Etabs, RAM, Tekla, SDS/2, Advance Steel, Trimble Connect, Idea StatiCA, | Preliminary BIM estimation model.     | BIM-DFE Model: BIM model that incorporates the resources of the manufacturer and assembler that were previously selected.  |
| Fabrication.             | Fabricator, transporter, erector.           | Tekla project viewer, Trimble connect, SDS/2, Tekla, Advance Steel.          | BIM-DFE Model.                        | BIM-DFE Updated: Updated BIM model with graphic and non-graphic elements that provide information on the manufacturing status (material preparation, assembly, welding, painting, dispatch). |
| Transportation.          | Fabricator, transporter, erector.           | Fortosi, Tekla Stacker.  | BIM-DFE Updated.                      | BIM-DFE on site Collection: BIM model with the classification of the elements to be transported and prioritization of the shipment according to the needs of the project.                    |
| Erection.                | Owner, fabricator, transporter, erector.    | Tekla project viewer, Trimble connect, SDS/2, Tekla, Advance Steel.          | BIM-DFE on site Collection.           | As built BIM-DFE steel structure erected model: Model to simulate material collection, erections and provide feedback on the status of the elements assembled on site.                       |

### 5.3 Research Question Q3.

Research Question Q3 investigates the quantitative impact of implementing the BIM-based process map for steel construction projects, stemming from objectives 2.1 and 2.2, within an authentic case study. This section presents outcomes and implications of the two case studies. The first study employed the traditional CAD-BIM approach for planning, designing, and fabricating a steel construction project. The second study utilized the BIM-DFE methodology, validated by industry and scientific experts, but not yet applied practically.

#### *Planning Phase*

In case study 1, the traditional CAD-BIM methodology was used in the planning, design, and fabrication phases of a steel construction project, in which a total of 140 h was spent on planning: 60 h by the project manager/senior engineer and 80 h by a senior draftsman. The software tools used were AutoCAD and SAP2000. One disadvantage in this case was the use of two software tools that did not consider the transfer of nongraphical information between them, which slowed the planning process. Moreover, the presentation of 2D drawings to the client, who was not an expert in the construction industry, hindered their understanding of the project, which increased the period until the final design was approved.

In contrast, in the planning phase of case study 2, BIM tools following the BIM-DFE methodology were used together with the software tools Tekla and SAP2000. The use of BIM in this phase helped the client understand the final design, which was presented in 3D, thereby accelerating the planning process. The transfer of information between the software tools was bidirectional in the IFC format, allowing interactions regardless of the geographic

location because the model was shared in the Trimble Connect cloud of Tekla. The senior engineer spent a total of 40 h in the planning phase. The hours spent by the draftsman were not considered because the same engineer/project manager conducted both the modeling and verification following the client's approval. It should be noted that while the project sizes were significantly different, the typology was the same. As the project in case study 1 was significantly smaller than that in case study 2, the total hours spent in case study 2 was considerably lower, indicating improved performance.

Note that the objective of planning in both cases was to determine the quantity of steel (in tons) that could be processed to estimate the costs. Therefore, it can be concluded that the use of BIM technology following the BIM-DFE methodology in case study 2 improved the performance in the planning phase compared with that in case study 1, which used traditional CAD-BIM methodology. The reduced number of the hours spent on planning in case study 2 highlights the efficiency and effectiveness of applying BIM technology in the construction industry.

The traditional CAD-BIM method in the planning phase suffers from the drawback of limited integration between BIM and non-BIM software (e.g., AutoCAD and SAP2000). This could slow the process owing to the need to manually transfer nongraphical information between different software platforms. In addition, 2D drawings are not as effective as 3D models in communicating the design intent to the owner, which can lead to delays in the approval process and potentially increase the number of hours required to complete the planning phase. Another disadvantage is that the traditional CAD-BIM method could require more specialized personnel, such as a senior project manager and draftsman, compared with the BIM-DFE method, which requires fewer personnel with more diverse skill sets.

### *Design Phase*

In case study 1, the CAD-BIM utilized the traditional CAD method, in which the structural design was modeled in SAP engineering software and required 80 h from the senior engineer. After the analysis, a total of 100 h were spent on drawing: 60 h and 40 h by the senior and junior AutoCAD draftsman, respectively. The final design was disapproved by the client, and this required the engineer and senior AutoCAD draftsman to spend an additional 45 and 35 h, respectively, making necessary changes. This rejection was attributed to the client's inability to understand the 2D plans, which prompted design changes. Finally, the senior engineer spent an additional 40 h calculating the connections, while the senior and junior draftsmen spent 50 and 40 h, respectively, representing the connections in 2D. An additional 60 h of drawing were required to complete the 2D deliverable in this phase.

In case study 2, the implementation of BIM-DFE utilized a BIM estimation derived from the previous planning phase. This facilitated the efficient exchange of information in the IFC file format for seamless integration with the SAP2000 calculation software. This process required only 20 h from the senior engineer. The need for draftsmen was eliminated as the model was seamlessly transferred bidirectionally to Tekla, and then to Trimble Connect for client comprehension. The manufacturing plant constraints were seamlessly integrated at this stage, which required an additional 12 h of the engineer/project manager's time and 8 h of the senior manufacturing manager's time. This early communication fostered an enriched BIM, enabling the analysis of connections that required an additional 10 h of the senior engineer's time. To ensure the feasibility of these connections, an additional 15 h of the senior engineer's time were allocated for verification purposes.

A comparison of the two cases showed that the use of BIM in the design phase has several advantages over traditional CAD methods. BIM facilitates the transfer of information for a more efficient design process with fewer errors. The early incorporation of manufacturing constraints helps identify potential issues, saves time, and reduces the likelihood of expensive changes in the future. In addition, the BIM model improves the visualization and facilitates the client's understanding of the design, thereby reducing the risk of design changes due to misunderstanding. Furthermore, apart from the proven advantages highlighted in the case study, it is crucial to recognize that there are numerous other established and valuable benefits associated with BIM. These encompass improved collaboration, optimized project scheduling, and enhanced facility management. These additional advantages greatly contribute to the overall value and efficacy of BIM in construction projects.

In contrast, the traditional CAD method required more time and resources in the design phase, as seen in case study 1. Design changes were extensive and required significant additional time from the senior engineer and AutoCAD draftsmen. In addition, the 2D plan format made it difficult for the client to understand the design, leading to further design changes.

Overall, the use of BIM-DFE in the design phase has clear benefits over the traditional CAD method. It facilitates a more efficient and effective design process and reduces the likelihood of expensive changes and misunderstandings.

### *Fabrication Phase*

Subsequently, an evaluation is conducted regarding the advantages and disadvantages inherent in employing a manual production planning process within case study 1. Conversely, in case study 2, BIM technology was employed for meticulous planning and detailed modeling, emphasizing a deliberate prioritization of fabrication elements.

#### *Advantages and Disadvantages in Case Study 1*

In case study 1, the production planning process required 40 h to manually extract information from the 2D drawing files. This manual process is prone to errors and could cause delays in the production process. In addition, the nesting process required 20 h and preparation 2.5 h/ton of steel.

The assembly and welding subprocess required 9.5 h/ton. The painting subprocess required 0.5 h/t, which is relatively fast but may be insufficient for large-scale projects.

#### *Advantages and Disadvantages in Case Study 2*

In case study 2, the production planning process required only 1 h because information from the previous stage was already available in the BIM model. Obtaining the details of the parts to be fabricated was significantly faster because of the automated process. The cleaning routines for the drawings were preconfigured in Tekla, which reduced errors and lead times.

The information for nesting and production tracking was extracted in 2.5 h using tools such as Tekla and STRUMIS. Material preparation using a CNC plasma machine resulted in a productivity rate of 2.5 h/ton, the same as that in case study 1. However, the assembly and welding subprocesses were significantly faster than those in case study 1, with a productivity

rate of 7 h/ton. This increase in productivity was attributed to the clarity of information presented in the 3D models, reducing the need for consultation with the fabrication manager and minimizing the need for the assembly and welding personnel to leave their workstations. The availability of information in the 3D model improved the organization of the workload. The painting subprocess had a productivity rate of 0.6 h/ton, which is slightly better than that in case study 1. This was attributed to the size of Project 2 rather than the BIM-DFE.

Overall, the productivity indicator for case study 2 was 9.9 h/ton. This is a reduction of 2.6 h/ton and has a significantly positive impact on the manufacturing and construction durations of steel projects.

The use of BIM technology in the fabrication process offers several advantages over manual processing. Automated detailing, reduced errors, and increased clarity of information in the 3D model contribute to improved productivity. This improvement is particularly significant in critical subprocesses, such as assembly and welding. The use of BIM technology shortened lead times, reduced production costs, and increased customer satisfaction. However, the implementation of BIM-DFE requires investments in both software and personnel training.

BIM-DFE has proven to be a highly efficient methodology in the steel construction industry, as demonstrated by the case studies. BIM-DFE has the advantage of being specifically designed for steel construction by providing targeted solutions and optimizations for the unique challenges and requirements of this industry.

# CHAPTER 6

## Conclusions, contribution, future directions and limitations

The present chapter shows the conclusion and future directions obtained from each of the research questions of this PhD thesis.

### 6.1 Research Question Q1.

What are the use cases of BIM in steel building projects?

The literature review made to answer this question identified 15 uses of BIM in the life cycle of steel construction projects, which were then grouped into three categories: 1. Project collaboration: Geometric Semantic; 2. Transfer information, visualization API, AR, and VR; and 3. Management, Sustainable, and Site Organization.

Regarding the first segment, BIM uses with the greatest presence in the steel construction phases were BU#1 (3D BIM model to visualize and improve the steel process) and BU#3 (early integration between design, manufacture, and assembly based on BIM models).



For the second segment, the use of BIM and augmented reality, BU#6 stands out with greater presence; with less presence, it shows the use of APIs for transferring non-geometric information between BIM models (BU#8).

Related to the third segment, the use of BIM with the greatest presence is cost analysis (BU#11) and the use of BIM for construction management (BU#12). Conversely, the least frequent use found for this segment was BU#13 (structural health monitoring with BIM models).

In the steel construction processes, BIM is mostly used in the design, fabrication, and erection stages. Conversely, planning and transportation have the least number of BIM uses. According to the SLR, most BIM uses for steel construction have been published as research work between Asia and North America; the rest are distributed between Europe and Africa. However, there is no evidence for BIM use cases in South America.

Regarding the historical evolution of scientific publications on BIM uses in steel construction, an evolution was observed between 2012 and 2022, and 2019 was the year with the most publications pertaining to this topic. However, over the last three years, the number of publications has decreased, likely due to the reduction in investments worldwide as a result of the COVID-19 pandemic. This, in turn, has affected drop-in construction projects and, consequently, the potential use cases that can be documented.

Early integration highlights the use of a BIM model as a pivot among the designer, manufacturer, and erector, which reduces the cost and time associated with steel building projects. It is recommended to adopt this early integration in the design stage because it

permits collaboration and validation between the different actors involved in the materialization of the project.

Notably, some BIM uses are not widespread in the steel construction industry; these include the combination of BIM for structural health monitoring (BU#13), the use of API for transferring non-geometric information (BU#8 or BU# 15), and BIM for the de-constructability and identification of reusable materials.

Regarding the tools used for BIM modeling, Tekla appears in 87% of the uses, mainly in the design and manufacturing phases; other software, such as Revit, MicroStation, and Naviswork, are frequently mentioned in the design and erection stages.

#### *Use of 3D BIM in Collaborative Steel Building Projects: Geometric and Semantic*

The review of scientific literature revealed that, in the segment of geometry and semantics, BIM is widely used in the design and manufacturing phases, albeit to a lesser extent than in the fabrication and design phases. No evidence related to transportation was found in this segment. Considering the benefits of BIM, it is recommended that further studies focus on these three phases, which are less prominent in existing literature.

#### *Utilization of BIM Information in Steel Building Projects: Information Transfer, Visualization API, AR, and VR*

In this segment, the transfer of information through the different phases involved in steel construction is widely mentioned. Few reports focus on the transfer of non-geometric information between the BIM models through APIs for steel construction projects. Hence, this topic is recommended to be addressed in future research.

### *Use of BIM for Steel Project Management, Sustainability, and Site Organization*

According to the bibliographic review of literature, in this segment, all the phases show at least one BIM use. It is noteworthy that, in this segment, where the use of BIM is framed in the costs and logistics of the project, the manufacturing and transportation phases are the ones with the least presence. Therefore, it is recommended that these uses be treated under future research.

According to the SLR, 65% of the uses of BIM for steel construction have been published as research work from Asia and North America, with the rest distributed between Europe and Africa. However, there is no evidence related to BIM use cases in South America. This indicates a gap related to disseminating the uses of BIM in steel construction, which needs to be addressed in future research, especially with reference to this continent.

All these guidelines for future research are recommended to be addressed by the scientific community, with support from the most critical stakeholders and the industry.

### *Contribution to Scientific Community, research question 1.*

The contribution of this work to the scientific community is the identification of BIM uses for steel projects. Based on this review, it can be determined how, when, and where BIM uses are executed in steel building projects. This answers the previously posed research question regarding the use of BIM in steel building projects. In addition, it identified the uses with greater and lesser disclosures, as well as future research directions.

### *Future Research Directions, research question 1.*

The review of scientific literature revealed that, in the segment of geometry and

semantics, BIM is widely used in the design and manufacturing phases, albeit to a lesser extent than in the fabrication and design phases. No evidence related to transportation was found in this segment. Considering the benefits of BIM, it is recommended that further studies focus on these three phases, which are less prominent in existing literature.

## **6.2 Research Question Q2.**

Is it possible to merge the scientific knowledge and the industry experience, in order to create an original BIM integration model to improve the management of steel building projects?

The use of an integrated BIM, BIM-DFE, is proposed to guide a systematic, efficient, and effective steel construction. The BIM model is to be used for communication between all stakeholders, such as the client and designers, designer and fabricator, designer and erector, and erector and fabricator, to ensure the success of the steel building project. BIM-DFE improves construction plans by determining the most economical and sustainable plan.

After two rounds of the Delphi method, an integrated BIM-use BIM-DFE (BIM for design, fabrication, and erection in steel construction projects) consensus was reached by the panel of experts. BIM-DFE is an integration proposal for using BIM throughout the steel construction lifecycle. The BIM-DFE should be used as a federated BIM 3D model and must be nurtured in different stages; this transfer of information should be through open BIM collaboration files such as IFC.

The use of BIM is most prominent in the planning and design phases, which is highlighted in the preliminary analyses of the costs of fabrication, transportation, and erection of the steel structure, aiming to improve the understanding of decision-makers, especially emphasizing

the planning and design phases, and integrating the resources of the remaining stakeholders at the disposal of an optimized design.

Finally, it is imperative to add information related to transport simulation to the BIM models in the design stage. This permits the classification of the elements to be transported to conduct a follow-up and prioritize the shipment according to the needs of the project. Although these are not typically included, they significantly impact the total cost of the project.

*Contribution to Scientific Community, research question 2.*

The contribution to the scientific community is the consensus of BIM integration use based on scientific evidence validated by the critical stakeholders in the industry.

*Future Research Directions, research question 2.*

Considering that the problems of BIM usage in steel buildings presented in this study can be extrapolated to other building materials, it is proposed for performing a methodological expert consensus for other materials, such as concrete and wood, where the findings of the scientific literature can be integrated into a methodology with the relative consensus of experts in the industry. Finally, it is proposed to make a comparison of BIM-DFE with other taxonomies accepted by the industry that could be left out of this scope of work.

Limitations: The literature reviewed for question 2 was limited to the last ten years; only peer-reviewed publications were included, BIM organizations, doctoral theses, and proceedings were excluded. Moreover, the experts in this study had experience only in Europe, Latin America, and North America. Furthermore, the investigation was framed only for integrating BIM usage in the different phases of steel building projects.

### 6.3 Research Question Q3.

How does the implementation of the BIM-based process map for steel construction projects BIM-DFE, quantitatively influence outcomes when applied to a real-world case study?

The analysis of the results of case studies 1 and 2 using the CAD-BIM and BIM-DFE methodologies, respectively, showed that BIM significantly improved the efficiency and productivity of the steel planning, design, and fabrication phases.

In case study 1, the manual extraction of information from 2D drawings extended the planning process, which led to longer processing times in the subsequent fabrication phase. In contrast, case study 2 exhibited notable improvements in planning and design, leading to a significant decrease in the duration of the fabrication phase, particularly the assembly and welding subprocesses. Case study 2 also demonstrated that the BIM-DFE methodology facilitated the automation of steel detailing by incorporating manufacturer constraints, resulting in a significant reduction in the time required for this process. BIM-DFE also reduced the need for human intervention, resulting in fewer errors and a more streamlined fabrication process.

The BIM-DFE methodology offers a more integrated approach, continuously enriching the model's information from planning to fabrication, which ultimately results in a more efficient and effective process for all stakeholders. It can be concluded that the BIM-DFE methodology was not only validated by the literature and industry experts but also by its application to a real case in this study.

*Future Research Directions, research question 3.*

Potential directions for future research related to this study include the following:

Evaluation of the impact of BIM-DFE on the construction, transport, and installation processes;

Exploration of the potential benefits of BIM-DFE in different types of construction projects, such as those using different materials or construction methods;

Development of new tools and workflows to enhance the integration of BIM and DFE methodologies, such as the integration of optimization algorithms and machine learning techniques.

Limitations: Among the limitations of this study is its focus on the planning, design, and fabrication phases of the project. Other phases, i.e., transportation and erection, were excluded owing to the timeline of the project

# REFERENCES

- Abou Diakité, A., & Zlatanova, S. (2016). Valid Space Description in BIM for 3D Indoor Navigation. *International Journal of 3-D Information Modeling*, 5(3), 1–17.  
<https://doi.org/10.4018/ij3dim.2016070101>
- AbouHamad, M., & Abu-Hamd, M. (2019). Framework for construction system selection based on life cycle cost and sustainability assessment. *Journal of Cleaner Production*, 241.  
<https://doi.org/10.1016/j.jclepro.2019.118397>
- Akanbi, L. A., Oyedele, L. O., Akinade, O. O., Ajayi, A. O., Davila Delgado, M., Bilal, M., & Bello, S. A. (2018). Salvaging building materials in a circular economy: A BIM-based whole-life performance estimator. *Resources, Conservation and Recycling*, 129(May 2017), 175–186.  
<https://doi.org/10.1016/j.resconrec.2017.10.026>
- Akanmu, A., & Okoukoni, F. (2018). Swarm nodes for automated steel installation tracking: A case study. *Automation in Construction*, 90(June 2017), 294–302.  
<https://doi.org/10.1016/j.autcon.2018.01.011>
- Alattas, A., Kalogianni, E., Alzahrani, T., Zlatanova, S., & van Oosterom, P. (2021). Mapping private, common, and exclusive common spaces in buildings from BIM/IFC to LADM. A case study from Saudi Arabia. *Land Use Policy*, 104. <https://doi.org/10.1016/j.landusepol.2021.105355>
- Aleksandrov, M., Diakité, A., Yan, J., Li, W., & Zlatanova, S. (2019). SYSTEMS ARCHITECTURE for MANAGEMENT of BIM, 3D GIS and SENSORS DATA. *ISPRS Annals of the Photogrammetry, Remote Sensing and Spatial Information Sciences*, 4(4/W9), 3–10.  
<https://doi.org/10.5194/isprs-annals-IV-4-W9-3-2019>
- Alizadehsalehi, S., Hadavi, A., & Huang, J. C. (2020). From BIM to extended reality in AEC industry. *Automation in Construction*, 116. <https://doi.org/10.1016/j.autcon.2020.103254>
- Alreshidi, E., Mourshed, M., & Rezgui, Y. (2017). Factors for effective BIM governance. *Journal of Building Engineering*, 10(July 2016), 89–101. <https://doi.org/10.1016/j.jobbe.2017.02.006>
- An, S., Martinez, P., Al-Hussein, M., & Ahmad, R. (2020). Automated verification of 3D manufacturability for steel frame assemblies. *Automation in Construction*, 118(May).  
<https://doi.org/10.1016/j.autcon.2020.103287>
- Arayici, Y., Fernando, T., Munoz, V., & Bassanino, M. (2018). Interoperability specification development for integrated BIM use in performance based design. *Automation in Construction*, 85, 167–181. <https://doi.org/10.1016/j.autcon.2017.10.018>
- Asgari Siahboomy, M., Sarvari, H., Chan, D. W. M., Nassereddine, H., & Chen, Z. (2021). A multi-criteria optimization study for locating industrial warehouses with the integration of BIM and



- GIS data. *Architectural Engineering and Design Management*, 17(5–6), 478–495.  
<https://doi.org/10.1080/17452007.2021.1881880>
- Avendaño, J. I., Zlatanova, S., Pérez, P., Domingo, A., & Correa, C. (2022a). Integration of BIM in Steel Building Projects (BIM-DFE): A Delphi Survey. *Buildings*, 12(9).  
<https://doi.org/10.3390/buildings12091439>
- Avendaño, J. I., Zlatanova, S., Domingo, A., Pérez, P., & Correa, C. (2022b). Utilization of BIM in Steel Building Projects: A Systematic Literature Review. *Buildings*, 12(6).  
<https://doi.org/10.3390/buildings12060713>
- Azhar, S., & Asce, A. M. (2011). Building Information Modeling (BIM): Trends, Benefits, Risks, and Challenges for the AEC Industry. In *Leadership Manage. Eng* (Vol. 11).
- Bahamid, R. A., Doh, S. I., Khoiry, M. A., Kassem, M. A., & Al-Sharafi, M. A. (2022). The Current Risk Management Practices and Knowledge in the Construction Industry. *Buildings*, 12(7).  
<https://doi.org/10.3390/buildings12071016>
- Barbosa, F., Woetzel, J., Mischke, J., Ribeirinho, M. J., Sridhar, M., Parsons, M., Bertram, N., & Brown, S. (2017). Reinventing Construction: A Route To Higher Productivity. *Mckinsey Global Insititute, February*, 168. <http://www.mckinsey.com/industries/capital-projects-and-infrastructure/our-insights/reinventing-construction-through-a-productivity-revolution>
- Barg, S., Flager, F., & Fischer, M. (2018). An analytical method to estimate the total installed cost of structural steel building frames during early design. *Journal of Building Engineering*, 15, 41–50. <https://doi.org/10.1016/j.jobe.2017.10.010>
- Bartenbach, J., Schindler, S., Schulze, F., & Kulzer, W. (2019). Stahlbau unter Nutzung von BIM in einem heterogenen Softwareumfeld. In *Stahlbau* (Vol. 88, Issue 8, pp. 786–795).  
<https://doi.org/10.1002/stab.201900019>
- Basta, A., Serror, M. H., & Marzouk, M. (2020). A BIM-based framework for quantitative assessment of steel structure deconstructability. *Automation in Construction*, 111(October 2019), 103064. <https://doi.org/10.1016/j.autcon.2019.103064>
- Biggs, S. E., Banks, T. D., Davey, J. D., & Freeman, J. E. (2013). Safety leaders' perceptions of safety culture in a large Australasian construction organisation. *Safety Science*, 52, 3–12.  
<https://doi.org/10.1016/j.ssci.2012.04.012>
- Bortolini, R., Formoso, C. T., & Viana, D. D. (2019). Site logistics planning and control for engineer-to-order prefabricated building systems using BIM 4D modeling. *Automation in Construction*, 98(October 2018), 248–264. <https://doi.org/10.1016/j.autcon.2018.11.031>
- Bryde, D., Broquetas, M., & Volm, J. M. (2013). The project benefits of building information modelling (BIM). *International Journal of Project Management*, 31(7), 971–980.  
<https://doi.org/10.1016/j.ijproman.2012.12.001>
- Case, F., Beinat, A., Crosilla, F., & Alba, I. M. (2014). Virtual trial assembly of a complex steel structure by Generalized Procrustes Analysis techniques. *Automation in Construction*, 37, 155–165. <https://doi.org/10.1016/j.autcon.2013.10.013>

- Cerezo-Narváez, A., Pastor-Fernández, A., Otero-Mateo, M., & Ballesteros-Pérez, P. (2021). The relationship between building agents in the context of integrated project management: A prospective analysis. In *Buildings* (Vol. 11, Issue 5).  
<https://doi.org/10.3390/buildings11050184>
- Chen, H. M., & Huang, P. H. (2013). 3D AR-based modeling for discrete-event simulation of transport operations in construction. *Automation in Construction*, *33*, 123–136.  
<https://doi.org/10.1016/j.autcon.2012.09.015>
- Chen, L. K., Yuan, R. P., Ji, X. J., Lu, X. Y., Xiao, J., Tao, J. B., Kang, X., Li, X., He, Z. H., Quan, S., & Jiang, L. Z. (2021). Modular composite building in urgent emergency engineering projects: A case study of accelerated design and construction of Wuhan Thunder God Mountain/Leishenshan hospital to COVID-19 pandemic. *Automation in Construction*, *124*.  
<https://doi.org/10.1016/j.autcon.2021.103555>
- Chen, S., Wu, J., & Shi, J. (2020). A bim platform for the manufacture of prefabricated steel structure. *Applied Sciences (Switzerland)*, *10*(22), 1–20.  
<https://doi.org/10.3390/app10228038>
- Costin, A., Hu, H., & Medlock, R. (2021). Building information modeling for bridges and structures: Outcomes and lessons learned from the steel bridge industry. *Transportation Research Record*, *2675*(11), 576–586. <https://doi.org/10.1177/03611981211018691>
- Daspit, J. J. (2017). D. Andreini and C. Bettinelli: Business model innovation: from systematic literature review to future research directions. *Journal of Management & Governance*, *21*(3), 785–792. <https://doi.org/10.1007/s10997-017-9388-2>
- Deng, M., Menassa, C. C., & Kamat, V. R. (2021). From BIM to digital twins: A systematic review of the evolution of intelligent building representations in the AEC-FM industry. *Journal of Information Technology in Construction*, *26*, 58–83.  
<https://doi.org/10.36680/J.ITCON.2021.005>
- Diakite, A. A., & Zlatanova, S. (2020). Automatic geo-referencing of BIM in GIS environments using building footprints. *Computers, Environment and Urban Systems*, *80*(December 2019), 101453. <https://doi.org/10.1016/j.compenvurbsys.2019.101453>
- Ding, K., Shi, H., Hui, J., Liu, Y., Zhu, B., Zhang, F., & Cao, W. (2018). *Smart steel bridge construction enabled by BIM and Internet of Things in industry 4.0: A framework*. 1–5.  
<https://doi.org/10.1109/ICNSC.2018.8361339>
- Ding, Z., Liu, S., Liao, L., & Zhang, L. (2019). A digital construction framework integrating building information modeling and reverse engineering technologies for renovation projects. *Automation in Construction*, *102*(January), 45–58.  
<https://doi.org/10.1016/j.autcon.2019.02.012>
- Disney, O., Roupé, M., Johansson, M., & Domenico Leto, A. (2022). Embracing BIM in its totality: a Total BIM case study. *Smart and Sustainable Built Environment*.  
<https://doi.org/10.1108/SASBE-06-2022-0124>

- Erfurth, L. (2019). BIM im Stahlbau: etablierte Arbeitsweisen und neue Wege. *Stahlbau*, 88(3), 214–222. <https://doi.org/10.1002/stab.201900008>
- Evans, M., & Farrell, P. (2021). Barriers to integrating building information modelling (BIM) and lean construction practices on construction mega-projects: a Delphi study. *Benchmarking*, 28(2), 652–669. <https://doi.org/10.1108/BIJ-04-2020-0169>
- Galic, M., Dolacek-Alduk, Z., Cerovecki, A., Glick, D., & Abramovic, M. (2015). BIM in planning deconstruction projects. *EWork and EBusiness in Architecture, Engineering and Construction - Proceedings of the 10th European Conference on Product and Process Modelling, ECPPM 2014*, 81–85. <https://doi.org/10.1201/b17396-17>
- García-Pereira, I., Portalés, C., Gimeno, J., & Casas, S. (2020). A collaborative augmented reality annotation tool for the inspection of prefabricated buildings. *Multimedia Tools and Applications*, 79(9–10), 6483–6501. <https://doi.org/10.1007/s11042-019-08419-x>
- Ghaleb, H., Alhajlah, H. H., bin Abdullah, A. A., Kassem, M. A., & Al-Sharafi, M. A. (2022). A Scientometric Analysis and Systematic Literature Review for Construction Project Complexity. *Buildings*, 12(4). <https://doi.org/10.3390/buildings12040482>
- Ginigaddara, B., Perera, S., Feng, Y., & Rahnamayiezekavat, P. (2022). Development of an offsite construction typology: A delphi study. *Buildings*, 12(1). <https://doi.org/10.3390/buildings12010020>
- Gutowski, T., Cooper, D., & Sahni, S. (2017). Why we use more materials. In *Philosophical Transactions of the Royal Society A: Mathematical, Physical and Engineering Sciences* (Vol. 375, Issue 2095). Royal Society. <https://doi.org/10.1098/rsta.2016.0368>
- Hyarat, E., Hyarat, T., & Al Kuisi, M. (2022). Barriers to the Implementation of Building Information Modeling among Jordanian AEC Companies. *Buildings*, 12(2), 1–18. <https://doi.org/10.3390/buildings12020150>
- IA, R., Haggag SY, A., I, M., & HM, E. (2016). Construction Performance Control in Steel Structures Projects. *Industrial Engineering & Management*, 05(04). <https://doi.org/10.4172/2169-0316.1000201>
- Isikdag, U., Zlatanova, S., & Underwood, J. (2013). A BIM-Oriented Model for supporting indoor navigation requirements. *Computers, Environment and Urban Systems*, 41, 112–123. <https://doi.org/10.1016/j.compenvurbsys.2013.05.001>
- Jeong, W. S., Chang, S., Son, J. W., & Yi, J. S. (2016). BIM-integrated construction operation simulation for just-in-time production management. *Sustainability (Switzerland)*, 8(11), 1–26. <https://doi.org/10.3390/su8111106>
- Jeon, K., Lee, G., Kang, S., Roh, H., Jung, J., Lee, K., & Baldwin, M. (2021). A relational framework for smart information delivery manual (IDM) specifications. *Advanced Engineering Informatics*, 49. <https://doi.org/10.1016/j.aei.2021.101319>

- Kaewunruen, S., Peng, S., & Phil-Ebosie, O. (2020). Digital twin aided sustainability and vulnerability audit for subway stations. *Sustainability (Switzerland)*, *12*(19). <https://doi.org/10.3390/SU12197873>
- Kamunda, A., Renukappa, S., Suresh, S., & Jallow, H. (2021). BIM in the water industry: addressing challenges to improve the project delivery process. *Engineering, Construction and Architectural Management*, *28*(2), 510–529. <https://doi.org/10.1108/ECAM-12-2019-0692>
- Kim, K., Kim, G., Kim, K., Lee, Y., & Kim, J. (2009). Real-time progress management system for steel structure construction. *Journal of Asian Architecture and Building Engineering*, *8*(1), 111–118. <https://doi.org/10.3130/jaabe.8.111>
- Kim, K., Park, J. W., & Cho, C. (2020). Framework for Automated Generation of Constructible Steel Erection Sequences Using Structural Information of Static Indeterminacy Variation in BIM. *KSCE Journal of Civil Engineering*, *24*(11), 3169–3178. <https://doi.org/10.1007/s12205-020-0163-6>
- Kim, M. K., Wang, Q., Park, J. W., Cheng, J. C. P., Sohn, H., & Chang, C. C. (2016). Automated dimensional quality assurance of full-scale precast concrete elements using laser scanning and BIM. *Automation in Construction*, *72*, 102–114. <https://doi.org/10.1016/j.autcon.2016.08.035>
- Kim, S. W., & Brown, R. D. (2021). Urban heat island (UHI) intensity and magnitude estimations: A systematic literature review. In *Science of the Total Environment* (Vol. 779). Elsevier B.V. <https://doi.org/10.1016/j.scitotenv.2021.146389>
- Laefer, D. F., & Truong-Hong, L. (2017a). Toward automatic generation of 3D steel structures for building information modelling. *Automation in Construction*, *74*, 66–77. <https://doi.org/10.1016/j.autcon.2016.11.011>
- Laefer, D. F., & Truong-Hong, L. (2017b). Toward automatic generation of 3D steel structures for building information modelling. *Automation in Construction*, *74*, 66–77. <https://doi.org/10.1016/j.autcon.2016.11.011>
- LeBreton, J. M., & Senter, J. L. (2008). Answers to 20 questions about interrater reliability and interrater agreement. *Organizational Research Methods*, *11*(4), 815–852. <https://doi.org/10.1177/1094428106296642>
- Leon, H., Osman, H., Georgy, M., & Elsaid, M. (2018). System Dynamics Approach for Forecasting Performance of Construction Projects. *Journal of Management in Engineering*, *34*(1). [https://doi.org/10.1061/\(asce\)me.1943-5479.0000575](https://doi.org/10.1061/(asce)me.1943-5479.0000575)
- Liao, X., Fang, Z., Yu, J., Yang, Y., & Yang, S. (2012). Applications of BIM in erecting steel structure. *Applied Mechanics and Materials*, *193–194*, 1440–1443. <https://doi.org/10.4028/www.scientific.net/AMM.193-194.1440>
- Liu, L., Li, B., Zlatanova, S., & van Oosterom, P. (2021). Indoor navigation supported by the Industry Foundation Classes (IFC): A survey. In *Automation in Construction* (Vol. 121). Elsevier B.V. <https://doi.org/10.1016/j.autcon.2020.103436>

- Liu, Y. F., Luo, S. S., & Wang, H. (2021). Research on a Complete Set of Technologies for Assembled Residential Buildings with Steel-Structure Based on House Type Modularization and Component Standardization. *IOP Conference Series: Earth and Environmental Science*, 719(2). <https://doi.org/10.1088/1755-1315/719/2/022063>
- Liu, Y., Li, M., Wong, B. C. L., Chan, C. M., Cheng, J. C. P., & Gan, V. J. L. (2021). BIM-BVBS integration with openBIM standards for automatic prefabrication of steel reinforcement. *Automation in Construction*, 125. <https://doi.org/10.1016/j.autcon.2021.103654>
- Liu, Z. S., Wu, X. F., & Xu, R. L. (2014). Applied research of BIM technology on prestressed steel structures in Xuzhou stadium. *Applied Mechanics and Materials*, 444–445, 971–975. <https://doi.org/10.4028/www.scientific.net/AMM.444-445.971>
- Lucko, G., Asce, A. M., & Rojas, E. M. (n.d.). *Research Validation: Challenges and Opportunities in the Construction Domain*. <https://doi.org/10.1061/ASCECO.1943-7862.0000025>
- Malik, N., Ahmad, R., & Al-Hussein, M. (2019). Generation of safe tool-paths for automatic manufacturing of light gauge steel panels in residential construction. *Automation in Construction*, 98(July 2018), 46–60. <https://doi.org/10.1016/j.autcon.2018.11.023>
- Martinez, P., Ahmad, R., & Al-Hussein, M. (2019). A vision-based system for pre-inspection of steel frame manufacturing. *Automation in Construction*, 97(September 2018), 151–163. <https://doi.org/10.1016/j.autcon.2018.10.021>
- Mellado, F., Lou, E. C. W., & Becerra, C. L. C. (2020). Synthesising performance in the construction industry: An analysis of performance indicators to promote project improvement. *Engineering, Construction and Architectural Management*, 27(2), 579–608. <https://doi.org/10.1108/ECAM-09-2018-0419>
- Miettinen, R., & Paavola, S. (2014). Beyond the BIM utopia: Approaches to the development and implementation of building information modeling. *Automation in Construction*, 43, 84–91. <https://doi.org/10.1016/j.autcon.2014.03.009>
- Mischo, H., Seifried, J., Thiele, K., Schanzenbach, S., & Grassl, M. (2019). Vom 3-D-Laserscan zum BIM-Modell: Ein Erfahrungsbericht aus dem Stahlbrückenbau. *Bautechnik*, 96(7), 564–571. <https://doi.org/10.1002/bate.201900031>
- Moretti, N., Xie, X., Merino, J., Brazauskas, J., & Parlikad, A. K. (2020). An openbim approach to iot integration with incomplete as-built data. *Applied Sciences (Switzerland)*, 10(22), 1–17. <https://doi.org/10.3390/app10228287>
- Navaratnam, S., Ngo, T., Gunawardena, T., & Henderson, D. (2019). Performance review of prefabricated building systems and future research in Australia. In *Buildings* (Vol. 9, Issue 2). MDPI AG. <https://doi.org/10.3390/buildings9020038>
- Navaratnam, S., Satheeskumar, A., Zhang, G., Nguyen, K., Venkatesan, S., & Poologanathan, K. (2022). The challenges confronting the growth of sustainable prefabricated building construction in Australia: Construction industry views. *Journal of Building Engineering*, 48(2), 2–5. <https://doi.org/10.1016/j.jobe.2021.103935>

- Nekouvaght Tak, A., Taghaddos, H., Mousaei, A., & Hermann, U. (Rick). (2020). Evaluating industrial modularization strategies: Local vs. overseas fabrication. *Automation in Construction*, 114(February), 103175. <https://doi.org/10.1016/j.autcon.2020.103175>
- Ness, D., Swift, J., Ranasinghe, D. C., Xing, K., & Soebarto, V. (2015). Smart steel: New paradigms for the reuse of steel enabled by digital tracking and modelling. *Journal of Cleaner Production*, 98, 292–303. <https://doi.org/10.1016/j.jclepro.2014.08.055>
- Niu, Y., Lu, W., Liu, D., Chen, K., Anumba, C., & Huang, G. G. (2017). An SCO-Enabled Logistics and Supply Chain–Management System in Construction. *Journal of Construction Engineering and Management*, 143(3). [https://doi.org/10.1061/\(asce\)co.1943-7862.0001232](https://doi.org/10.1061/(asce)co.1943-7862.0001232)
- Olatunji, S. O., Olawumi, T. O., & Aje, I. O. (2017). Rethinking Partnering among Quantity-Surveying Firms in Nigeria. *Journal of Construction Engineering and Management*, 143(11), 05017018. [https://doi.org/10.1061/\(asce\)co.1943-7862.0001394](https://doi.org/10.1061/(asce)co.1943-7862.0001394)
- Olawumi, T. O., & Chan, D. W. M. (2019). Critical success factors for implementing building information modeling and sustainability practices in construction projects: A Delphi survey. *Sustainable Development*, 27(4), 587–602. <https://doi.org/10.1002/sd.1925>
- Oti, A. H., & Tizani, W. (2015). BIM extension for the sustainability appraisal of conceptual steel design. *Advanced Engineering Informatics*, 29(1), 28–46. <https://doi.org/10.1016/j.aei.2014.09.001>
- Ozcan Deniz, G. (2018). Emerging CAD and BIM trends in the AEC education: an analysis from students' perspective. In *Journal of Information Technology in Construction (ITcon)* (Vol. 23). Ozcan Deniz. <http://www.itcon.org/2018/7>
- Page, M. J., McKenzie, J. E., Bossuyt, P. M., Boutron, I., Hoffmann, T. C., Mulrow, C. D., Shamseer, L., Tetzlaff, J. M., Akl, E. A., Brennan, S. E., Chou, R., Glanville, J., Grimshaw, J. M., Hróbjartsson, A., Lalu, M. M., Li, T., Loder, E. W., Mayo-Wilson, E., McDonald, S., ... Moher, D. (2021). The PRISMA 2020 statement: An updated guideline for reporting systematic reviews. *Journal of Clinical Epidemiology*, 134, 178–189. <https://doi.org/10.1016/j.jclinepi.2021.03.001>
- Pan, W., & Zhang, Z. (2022). Evaluating Modular Healthcare Facilities for COVID-19 Emergency Response—A Case of Hong Kong. *Buildings*, 12(9). <https://doi.org/10.3390/buildings12091430>
- Paul, J., Lim, W. M., O’Cass, A., Hao, A. W., & Bresciani, S. (2021). Scientific procedures and rationales for systematic literature reviews (SPAR-4-SLR). *International Journal of Consumer Studies*. <https://doi.org/10.1111/ijcs.12695>
- Pellicer, E., Yepes, V., Correa, C. L., & Alarcón, L. F. (2012). Organizational improvement through standardization of the innovation process in construction firms. *EMJ - Engineering Management Journal*, 24(2), 40–53. <https://doi.org/10.1080/10429247.2012.11431935>

- Qiu, Q., Zhou, X., Zhao, J., Yang, Y., Tian, S., Wang, J., Liu, J., & Liu, H. (2021). From sketch BIM to design BIM: An element identification approach using Industry Foundation Classes and object recognition. *Building and Environment*, 188. <https://doi.org/10.1016/j.buildenv.2020.107423>
- Ramaji, I. J., Asce, A. M., Memari, A. M., Asce, F., & Messner, J. I. (2017). *Product-Oriented Information Delivery Framework for Multistory Modular Building Projects*. [https://doi.org/10.1061/\(ASCE\)](https://doi.org/10.1061/(ASCE))
- Ramaji, I. J., Messner, J. I., & Mostavi, E. (2020). IFC-Based BIM-to-BEM Model Transformation. *Journal of Computing in Civil Engineering*, 34(3). [https://doi.org/10.1061/\(asce\)cp.1943-5487.0000880](https://doi.org/10.1061/(asce)cp.1943-5487.0000880)
- Rashidian, S., Drogemuller, R., & Omrani, S. (2023). Building Information Modelling, Integrated Project Delivery, and Lean Construction Maturity Attributes: A Delphi Study. *Buildings*, 13(2). <https://doi.org/10.3390/buildings13020281>
- Review, L. (2022). *Utilization of BIM in Steel Building Projects : A Systematic Literature Review*.
- Sacks, R., Kedar, A., Borrmann, A., Ma, L., Brilakis, I., Hühwohl, P., Daum, S., Kattel, U., Yosef, R., Liebich, T., Barutcu, B. E., & Muhic, S. (2018). SeeBridge as next generation bridge inspection: Overview, Information Delivery Manual and Model View Definition. *Automation in Construction*, 90, 134–145. <https://doi.org/10.1016/j.autcon.2018.02.033>
- Saka, A. B., & Chan, D. W. M. (2020). Knowledge, skills and functionalities requirements for quantity surveyors in building information modelling (BIM) work environment: an international Delphi study. *Architectural Engineering and Design Management*, 16(3), 227–246. <https://doi.org/10.1080/17452007.2019.1651247>
- Sampaio, A. Z., Sequeira, P., Gomes, A. M., & Sanchez-Lite, A. (2023). BIM Methodology in Structural Design: A Practical Case of Collaboration, Coordination, and Integration. *Buildings*, 13(1). <https://doi.org/10.3390/buildings13010031>
- Scianna, A., Gaglio, G. F., & La Guardia, M. (2022). Structure Monitoring with BIM and IoT: The Case Study of a Bridge Beam Model. *ISPRS International Journal of Geo-Information*, 11(3). <https://doi.org/10.3390/ijgi11030173>
- Shahtaheri, Y., Rausch, C., West, J., Haas, C., & Nahangi, M. (2017). Managing risk in modular construction using dimensional and geometric tolerance strategies. *Automation in Construction*, 83, 303–315. <https://doi.org/10.1016/j.autcon.2017.03.011>
- Shan, Y., Goodrum, P., Haas, C., & Caldas, C. (2012). Assessing productivity improvement of quick connection systems in the steel construction industry using building information modeling (BIM). *Construction Research Congress 2012: Construction Challenges in a Flat World, Proceedings of the 2012 Construction Research Congress, Nbims 2011*, 1135–1144. <https://doi.org/10.1061/9780784412329.114>
- Shin, T. S. (2017). Building information modeling (BIM) collaboration from the structural engineering perspective. *International Journal of Steel Structures*, 17(1), 205–214. <https://doi.org/10.1007/s13296-016-0190-9>

- Sibenik, G., & Kovacic, I. (2020). Assessment of model-based data exchange between architectural design and structural analysis. *Journal of Building Engineering*, 32. <https://doi.org/10.1016/j.jobe.2020.101589>
- Soh, M. F., Barbeau, D., Doré, S., & Forgues, D. (2020). Qualitative analysis of Request for Information to identify design flaws in steel construction projects. *Organization, Technology and Management in Construction*, 12(1), 2083–2094. <https://doi.org/10.2478/otmcj-2020-0005>
- Soh, M. F., Bigras, D., Barbeau, D., Doré, S., & Forgues, D. (2022). Bim machine learning and design rules to improve the assembly time in steel construction projects. *Sustainability (Switzerland)*, 14(1). <https://doi.org/10.3390/su14010288>
- Son, S., Lee, G., Jung, J., Kim, J., & Jeon, K. (2022). Automated generation of a model view definition from an information delivery manual using idmXSD and buildingSMART data dictionary. *Advanced Engineering Informatics*, 54. <https://doi.org/10.1016/j.aei.2022.101731>
- Steel, J., Drogemuller, R., & Toth, B. (2012). Model interoperability in building information modelling. *Software and Systems Modeling*, 11(1), 99–109. <https://doi.org/10.1007/s10270-010-0178-4>
- Stern, C., Jordan, Z., & Mcarthur, A. (2014). *SYSTEMATIC REVIEWS, Step by Step Developing the Review Question and Inclusion Criteria* (Vol. 114, Issue 4).
- Stojanovska-Georgievska, L., Sandeva, I., Krleski, A., Spasevska, H., Ginovska, M., Panchevski, I., Ivanov, R., Arnal, I. P., Cerovsek, T., & Funtik, T. (2022). BIM in the Center of Digital Transformation of the Construction Sector—The Status of BIM Adoption in North Macedonia†. *Buildings*, 12(2). <https://doi.org/10.3390/buildings12020218>
- Succar, B. (2009). Building information modelling framework: A research and delivery foundation for industry stakeholders. *Automation in Construction*, 18(3), 357–375. <https://doi.org/10.1016/j.autcon.2008.10.003>
- Tang, S., Shelden, D. R., Eastman, C. M., Pishdad-Bozorgi, P., & Gao, X. (2019). A review of building information modeling (BIM) and the internet of things (IoT) devices integration: Present status and future trends. *Automation in Construction*, 101(June 2018), 127–139. <https://doi.org/10.1016/j.autcon.2019.01.020>
- Tang, S., Shelden, D. R., Eastman, C. M., Pishdad-Bozorgi, P., & Gao, X. (2020). BIM assisted Building Automation System information exchange using BACnet and IFC. *Automation in Construction*, 110. <https://doi.org/10.1016/j.autcon.2019.103049>
- Tavares, P., Costa, C. M., Rocha, L., Malaca, P., Costa, P., Moreira, A. P., Sousa, A., & Veiga, G. (2019). Collaborative Welding System using BIM for Robotic Reprogramming and Spatial Augmented Reality. *Automation in Construction*, 106(March), 102825. <https://doi.org/10.1016/j.autcon.2019.04.020>



- Thomas, H. R., & Ellis, R. D. (2017). Site Layout. In *Construction Site Management and Labor Productivity Improvement*. <https://doi.org/10.1061/9780784414651.ch04>
- Thomas, H. R., Ralph, P. E., & Ellis, D. (n.d.). *How to Improve the Bottom Line and Shorten the Project Schedule Construction Site Management and Labor Productivity Improvement*.
- Tian, J., Luo, S., Wang, X., Hu, J., & Yin, J. (2021). Crane Lifting Optimization and Construction Monitoring in Steel Bridge Construction Project Based on BIM and UAV. *Advances in Civil Engineering, 2021*. <https://doi.org/10.1155/2021/5512229>
- Tranfield, D., Denyer, D., & Smart, P. (n.d.). *Towards a Methodology for Developing Evidence-Informed Management Knowledge by Means of Systematic Review \**.
- Tricco, A. C., Tetzlaff, J., & Moher, D. (2011). The art and science of knowledge synthesis. *Journal of Clinical Epidemiology, 64*(1), 11–20. <https://doi.org/10.1016/j.jclinepi.2009.11.007>
- Tummalapudi, M., Killingsworth, J., Harper, C., & Mehaney, M. (2021). US Construction Industry Managerial Strategies for Economic Recession and Recovery: A Delphi Study. *Journal of Construction Engineering and Management, 147*(11). [https://doi.org/10.1061/\(asce\)co.1943-7862.0002175](https://doi.org/10.1061/(asce)co.1943-7862.0002175)
- Turk, Ž. (2020). Interoperability in construction – Mission impossible? *Developments in the Built Environment, 4*. <https://doi.org/10.1016/j.dibe.2020.100018>
- Valdés, H., Correa, C., & Mellado, F. (2018). Proposed model of sustainable construction skills for engineers in Chile. *Sustainability (Switzerland), 10*(9). <https://doi.org/10.3390/su10093093>
- Vaughan, J. L., Leming, M. L., Liu, M., & Jaselskis, E. (2013). Cost-Benefit Analysis of Construction Information Management System Implementation: Case Study. *Journal of Construction Engineering and Management, 139*(4), 445–455. [https://doi.org/10.1061/\(asce\)co.1943-7862.0000611](https://doi.org/10.1061/(asce)co.1943-7862.0000611)
- Vera-Puerto, I., Valdes, H., Correa, C., Agredano, R., Vidal, G., Belmonte, M., Olave, J., & Arias, C. (2020). Proposal of competencies for engineering education to develop water infrastructure based on “Nature-Based Solutions” in the urban context. *Journal of Cleaner Production, 265*. <https://doi.org/10.1016/j.jclepro.2020.121717>
- Wang, M., Wang, C. C., Sepasgozar, S., & Zlatanova, S. (2020). A systematic review of digital technology adoption in off-site construction: Current status and future direction towards industry 4.0. *Buildings, 10*(11), 1–29. <https://doi.org/10.3390/buildings10110204>
- Wang, M., Wang, C. C., Zlatanova, S., Sepasgozar, S., & Aleksandrov, M. (2021). Onsite quality check for installation of prefabricated wall panels using laser scanning. *Buildings, 11*(9). <https://doi.org/10.3390/buildings11090412>
- Wang, W. C., Weng, S. W., Wang, S. H., & Chen, C. Y. (2014). Integrating building information models with construction process simulations for project scheduling support. *Automation in Construction, 37*, 68–80. <https://doi.org/10.1016/j.autcon.2013.10.009>

- Wang, Y. G., He, X. J., He, J., & Fan, C. (2022). Virtual trial assembly of steel structure based on BIM platform. *Automation in Construction*, 141. <https://doi.org/10.1016/j.autcon.2022.104395>
- Wei, L. S., Wei, Q., & Sun, K. (2014). Development of BIM Technology in Steel Structure Design Software. *Applied Mechanics and Materials*, 501–504, 2546–2549. <https://doi.org/10.4028/www.scientific.net/AMM.501-504.2546>
- Wu, J., Asce, S. M., Zhang, J., & Asce, A. M. (2019). *New Automated BIM Object Classification Method to Support BIM Interoperability*. [https://doi.org/10.1061/\(ASCE\)CP.1943](https://doi.org/10.1061/(ASCE)CP.1943)
- Xie, Y., Li, C., & Li, Z. (2017). Smart building materials of BIM and RFID in LifeCycle management of steel structure. *Key Engineering Materials*, 723 KEM, 736–740. <https://doi.org/10.4028/www.scientific.net/KEM.723.736>
- Yang, L., Cheng, J. C. P., & Wang, Q. (2020). Semi-automated generation of parametric BIM for steel structures based on terrestrial laser scanning data. *Automation in Construction*, 112(March 2019), 103037. <https://doi.org/10.1016/j.autcon.2019.103037>
- Yoo, M., & Ham, N. (2020). Productivity analysis of documentation based on 3D model in plant facility construction project. *Applied Sciences (Switzerland)*, 10(3). <https://doi.org/10.3390/app10031126>
- Yoo, M., Kim, J., & Choi, C. (2019). Effects of BIM-based construction of prefabricated steel framework from the perspective of SMEs. *Applied Sciences (Switzerland)*, 9(9). <https://doi.org/10.3390/app9091732>
- Yoo, W. S., Lee, H. J., Kim, D. I., Kang, K. I., & Cho, H. (2012). Genetic algorithm-based steel erection planning model for a construction automation system. In *Automation in Construction* (Vol. 24, pp. 30–39). <https://doi.org/10.1016/j.autcon.2012.02.007>
- Yu, J., Wang, J., Hua, Z., & Wang, X. (2021). BIM-based time-cost optimization of a large-span spatial steel structure in an airport terminal building. *Journal of Facilities Management*, 1–7. <https://doi.org/10.1108/JFM-12-2020-0097>
- Zhang, Y., & Bai, L. (2015). Rapid structural condition assessment using radio frequency identification (RFID) based wireless strain sensor. *Automation in Construction*, 54, 1–11. <https://doi.org/10.1016/j.autcon.2015.02.013>
- Zhu, A., Pauwels, P., & de Vries, B. (2021). Smart component-oriented method of construction robot coordination for prefabricated housing. *Automation in Construction*, 129. <https://doi.org/10.1016/j.autcon.2021.103778>



# APPENDIX

# **APPENDIX 1**

## **Questions applied in the Delphi method**

# APPENDIX 1

## Questions applied in the Delphi method

**Table A1.** Questions for the First Round.

| Code | Questions  | Phase/<br>Software | Subprocess                               | BIM Uses         |
|------|--|--------------------|--|------------------|
| Q1   | According to your experience, please indicate if you agree whether the following phases are related to the steel building project: planning, design, fabrication, planning for construction, and erection. If so, do you think the last ones could operate in a single phase? Please indicate your level of agreement and explain your answer.               | -                  | -  | -                |
| Q2   | Considering your experience, please indicate your level of agreement with the statement that the budget process should be the first in the planning stage.   | Planning           | Project budget                           | -                |
| Q3   | Considering your experience, what is your level of agreement regarding a project manager who also fulfills the role of a design engineer being selected in the planning stages? Please explain your answer. Ref: planning process map.   | Planning           | Selection of the steel designer and P.M. | -                |
| Q4   | Considering your experience, what is your level of agreement regarding that a BIM estimation model should be created in the planning stage prior to the design and analysis phase to determine the number of tons to process prior to the selection of steel, transportation, and assembly suppliers? Please explain your answer. Ref: planning process map. | Planning           | Steel BIM estimation model               | B1, B4, B6, B11. |
| Q5   | What is your level of agreement regarding that the planning stage should end with communicating the guidelines and level of detail of the BIM models that will be developed in the following stages? Please explain your answer. Ref: planning process map.  | Planning           | BIM-DFE act.                             | -                |
| Q6   | What is your level of agreement regarding the design stage beginning with an act that frames the scopes and types of BIM deliverables of the project in the design phase? Ref: Design process map.   | Design             | BIM-DFE act.                             | -                |

|     |   |             |   |                 |
|-----|---|-------------|---|-----------------|
| Q7  | What is your level of agreement regarding the next sub-process being the entry of analytical information into the BIM estimation model to accurately determine the structural steel sections to be used? Ref: Design process map.   | Design      | Enter analytical information into the BIM-DFE model | B3.             |
| Q8  | What is your level of agreement regarding that in the design phase, following the design analysis subprocess, the steel connection will be made with a software that can process the connection types considering the inputs of the BIM model in the previous stage? Please justify your answer. Ref: Design process map. | Design      | Steel connection design                             | B1, B2.         |
| Q9  | What is your level of agreement regarding that the response in the quote of the potential suppliers (manufacturers, assembler) can be accelerated using the BIM model from the previous stages and that this influences the decision-making of the selection of suppliers? Ref: Design process map.                       | Design      | Selection of the steel fabricator and steel erector | B1, B2, B4, B6. |
| Q10 | What is your level of agreement regarding this phase ending with selecting the manufacturer, assembler, and a BIM model with the connections defined before manufacturing? Ref: Design process map.   | Design      | Steel BIM-DFE Model                                 | -               |
| Q11 | What is your level of agreement regarding the manufacturing stage beginning with the BIM model from the previous phase? Do you think this increases the speed and rigor in the manufacturing stage? Ref: Fabrication process map.   | Fabrication | Steel BIM-DFE Model                                 | -               |
| Q12 | What is your level of agreement regarding the following thread determining the manufacturing and assembly phases in the BIM model according to the needs of the project? Ref: Fabrication process map.  | Fabrication | Steel construction phases design                    | B6, B12         |
| Q13 | What is your level of agreement regarding the following thread detailing the structure to generate the parts and pieces for manufacturing and assembly? Please explain. Ref: Fabrication process map.   | Fabrication | Steel detailing process based on BIM-DFE model      | -               |
| Q14 | What is your level of agreement regarding the next sub-process being the fabrication of the structure and using the BIM model as a tool for portability in the manufacturing processes? Ref: Fabrication process map.   | Fabrication | Fabrication of the steel structure                  | B5              |
| Q15 | What is your level of agreement regarding the manufacturing process ending with a BIM model that obtains all the information based on the state of the manufactured process, and this is shared with the  | Fabrication | BIM-DFE model updated                               | -               |

|     |  |                              |  |               |
|-----|--|------------------------------|--|---------------|
|     | transporter and assembler? Please explain. Ref: Fabrication process map.   |                              |  |               |
| Q16 | What is your level of agreement regarding the transport phase beginning with the BIM model resulting from the previous phase? Please explain. Ref: Transport process map.  | Transport                    | BIM-DFE model updated                                      | -             |
| Q17 | What is your level of agreement regarding the following process in the transport phase prioritizing shipment according to the needs of the site? Ref: Transport process map.   | Transport                    | Add shipping prioritization according to the project needs | B14           |
| Q18 | What is your level of agreement regarding a BIM model being used to optimize the shipment according to the truck type to be used in the same previous process? Ref: Transport process map.   | Transport                    | Add shipping prioritization according to the project needs | B14           |
| Q19 | What is your level of agreement regarding this transportation phase ending with a BIM model with all the information on the shipping priorities according to the needs of the project and transportation resources? Ref: Transport process map.                            | Transport                    | Steel BIM-DFE on-site collection                           | -             |
| Q20 | What is your level of agreement regarding the planning and erection phase beginning with the BIM model fed from the previous stages? Ref: Erection process map,  | Planning for C. and Erection | Steel BIM-DFE on-site collection                           | -             |
| Q21 | What is your level of agreement regarding the next sub-process in the planning stage for erection being the simulation of the assembly structure considering the resources available in the field? Ref: Erection process map.  | Planning for C. and Erection | Control installation                                       | B9, B10, B13. |
| Q22 | What is your level of agreement regarding the assembly stage ending with a BIM model that has significant information regarding the project, reflects the final state of the steel elements, and is shared in real-time by all the stakeholders? Ref: Erection process map | Planning for C. and Erection | Steel BIM-DFE on-site collection                           | -             |
| Q23 | Based on your experience, what is your level of agreement regarding the BIM tools that are most used in the planning phase are the following: Revit, SDS/2, Tekla, Advance Steel, and CYPECAD? If you do not completely agree, please explain your answer.                 | Software                     | -  | -             |
| Q24 | According to your experience, what is your level of agreement regarding the BIM tools that are most used in the design phase are the following: SAP2000, Tekla Structural  | Software                     | -  | -             |



designer, ETABS, and RAM? If you do not agree completely, please argue your answer.

Q25 According to your experience, what is your level of agreement regarding the BIM tools that are most used in the manufacturing phase are the following: Tekla, SDS/2, Strumis, and Tekla PowerFab? If you do not completely agree or if you consider that certain software is missing, please comment and explain your response.

Q26 According to your experience, what is your level of agreement regarding the BIM tools that are most used in the transport phase are the following: SDS/2 Fortosi and Tekla Track loading? If you do not completely agree or if you consider that certain software is missing, please comment and explain your answer.

Q27 Do you feel it would be helpful to have a BIM model in the erection stage that reflects the physical state of the elements prior to erection?

Q28 Based on your experience, what is your level of agreement regarding the BIM information exchange format between the different phases being IFC? If you do not completely agree or if you consider that there is another software extension, please comment and justify your answer.

**Table A2.** Questions for the Second Round.

| <b>Code</b> | <b>Questions</b>  | <b>Phase/<br/>Software</b> | <b>Subprocess</b>      |
|-------------|---|----------------------------|------------------------|
| Q1          | According to your experience, please indicate your level of agreement with the following statement: The phases of steel building projects are planning, design, fabrication, and erection.  | -                          | -                      |
| Q2          | Considering your experience, please indicate your level of agreement regarding the planning process beginning with the need to build, followed by the selection of the type of project (industrial, commercial, etc.)? Ref. Planning process map. | Planning                   | Type of project        |
| Q3          | Considering your experience, please indicate your level of agreement regarding that a project manager should be selected in the planning phase? This project manager can be one of the project  | Planning                   | Selection of the steel |

|     |   |             |  |
|-----|---|-------------|--|
|     | stakeholders with experience in BIM usage for steel construction and the type of project selected. Ref: planning process map.   |             | designer and P.M.  |
| Q4  | Considering your experience, please indicate your level of agreement regarding a BIM estimation model being created in the planning phase prior to the design and analysis phases to determine an approximate number of steel tons to process prior to the selection of the steel fabricator, transportation, and erection suppliers in this phase.? Please explain your answer. Ref: planning process map. | Planning    | Steel BIM estimation model, Selection of the steel fabricator and steel erector. |
| Q5  | Please indicate your level of agreement regarding the planning stage ending with a BIM-act that would provide the communication guidelines and level of detail of the BIM models that will be developed in the following phases? Please explain your answer. Ref: planning process map.   | Planning    | -  |
| Q6  | Please indicate your level of agreement regarding the design stage beginning with a BIM-act that frames the scopes and types of BIM deliverables of the project in the design phase? Ref: Design process map.   | Design      | BIM-DFE act.   |
| Q7  | Please indicate your level of agreement regarding the next sub-process being the entry of the structural design information into the BIM model from the previous stage selected in the previous phase, and that in this design stage, the resources of the suppliers selected in the previous stage are also considered? Please explain. Ref: Design process map.   | Design      | Enter analytical information into the BIM-DFE model                              |
| Q8  | What is your level of agreement regarding that in the design phase, following the design analysis subprocess, the steel connection will be made with a software that can process the connection types considering the inputs of the BIM model in the previous stage? Please justify your answer. Ref: Design process map.   | Design      | Steel connection design  |
| Q9  | What is your level of agreement regarding the erection sequences of the project being defined in the following sub-process in this phase?   | Design      | Steel construction design  |
| Q10 | What is your level of agreement regarding this phase (design) ending with selecting the fabricator, erector, and a BIM model with the connections defined prior to fabrication? Ref: Design process map.  | Design      | Steel BIM-DFE Model  |
| Q11 | What is your level of agreement regarding the fabrication phase beginning with the BIM model from the previous design phase? Ref: Fabrication process map.  | Fabrication | Steel BIM-DFE Model  |

|     |  |                              |  |
|-----|--|------------------------------|--|
| Q12 | What is your level of agreement regarding the following subprocess detailing the steel structure (optimized and validated for the steel fabricator, transport, and erector) to generate the parts and pieces for fabrication and erection information? Please explain. Ref: Fabrication process map. | Fabrication                  | Steel Detailing process based on BIM-DFE model             |
| Q13 | What is your level of agreement regarding the following thread manufacturing the structure with the detailed documentation of the BIM model of the previous subprocess? Ref: Fabrication process map.  | Fabrication                  | Fabrication of the steel structure                         |
| Q14 | What is your level of agreement regarding that the BIM model would be used as a quality control tool in the steel fabrication process?   | Fabrication                  | Fabrication of the steel structure                         |
| Q15 | What is your level of agreement regarding the manufacturing process ending with a BIM model that obtains all the information regarding the state of the manufactured process, and would be shared with the transporter and erector? Please explain. Ref: Fabrication process map.                    | Fabrication                  | BIM-DFE model updated                                      |
| Q16 | What is your level of agreement regarding the transport phase beginning with the BIM model resulting from the previous phase? Please explain. Ref: Transport process map.  | Transport                    | BIM-DFE model updated                                      |
| Q17 | What is your level of agreement regarding the following dub process in the transport phase being prioritized for shipment according to the needs of the site? Ref: Transport process map.  | Transport                    | Add shipping prioritization according to the project needs |
| Q18 | What is your level of agreement regarding that in the same previous process, a BIM model is used to optimize the shipment according to the type of truck to be used? Ref: Transport process map.   | Transport                    | Add Shipping prioritization according to the project needs |
| Q19 | What is your level of agreement regarding this transportation phase ending with a BIM model with all the information on shipping priorities according to the needs of the project and transportation resources? Ref: Transport process map.  | Transport                    | Steel BIM-DFE on-site collection                           |
| Q20 | What is your level of agreement regarding the planning and erection phase beginning with the BIM model fed from the previous stages? Ref: Erection process map.  | Planning for C. and Erection | Steel BIM-DFE on-site collection                           |

|     |   |                              |  |
|-----|---|------------------------------|--|
| Q21 | What is your level of agreement regarding the next sub-process in the planning stage for the erection being the simulation of the assembly structure considering the resources available in the field?<br>Ref: Erection process map.  | Planning for C. and Erection | Monitoring of the elements erected on site |
| Q22 | What is your level of agreement regarding the assembly stage ending with a BIM model with significant information that reflects the final state of the steel elements and it being shared in real-time by all the stakeholders? Ref: Erection process map.  | Planning for C. and Erection | Steel BIM-DFE on-site collection           |
| Q23 | Based on your experience, what is your level of agreement regarding the BIM tools that are most used in the Planning phase are as follows: Revit, SDS/2, and Tekla? If you do not completely agree, please explain your answer.   | Software                     | -  |
| Q24 | According to your experience, what is your level of agreement regarding the BIM tools that are most used in the design phase are as follows: SAP2000, Tekla Structural designer, ETABS, and RAM? If you do not completely agree, please explain your answer.  | Software                     | -  |
| Q25 | According to your experience, what is your level of agreement regarding the BIM tools that are most used in the manufacturing phase are as follows: Tekla, SDS/2, Advance Steel, Steel Project, Strumis, Power Fab. If you do not completely agree or if you consider that certain software is missing, please comment and explain your response. | Software                     | -  |
| Q26 | According to your experience, what is your level of agreement regarding the most used BIM tools in the transport phase are as follows: SDS/2 Fortosi and Tekla Track loading? If you do not completely agree or if you consider that certain software is missing, please comment and explain your answer.   | Software                     | -  |
| Q27 | Do you feel it would be helpful to have a Tekla, Revit, SDS/2, Naviswork, or Trimble Connect BIM model in the erection stage that reflects the physical state of the elements prior to erection? Please explain.  | Software                     | -  |
| Q28 | Based on your experience, what is your level of agreement regarding the BIM information exchange format between the different phases being IFC? If you do not completely agree or if you consider that there is another software extension, please comment and justify your answer.   | Software                     | -  |

## **APPENDIX 2**

**Impact factor in the Journal Citation Reports (JCR) of the articles that constitute the body of this thesis**

# APPENDIX 2

## Impact factor in the Journal Citation Reports (JCR) of the articles that constitute the body of this thesis

According to Clarivate's JCR, the journals indexed in SCIE/SSCI have an impact factor.

**Buildings Ranking**

|                             |                              |  |                     |
|-----------------------------|------------------------------|--|---------------------|
| <b>Impact Factor:</b> 3.324 | <b>Total Citations:</b> 3842 | <b>SJR (SCImago Journal Rank):</b> 0.605 | <b>Quartile:</b> Q1 |
|-----------------------------|------------------------------|--|---------------------|

The Impact Factor of Buildings is 3.324.

The impact factor (IF) is a measure of the frequency with which the average article in a journal has been cited in a particular year. It is used to measure the importance or rank of a journal by calculating the times its articles are cited.

|                       |  |
|-----------------------|--|
| <b>Journal Title:</b> | Buildings  |
| <b>Publisher:</b>     | Multidisciplinary Digital Publishing Institute (MDPI)                                    |
| <b>ISSN:</b>          | 20755309   |
| <b>Type:</b>          | journal  |
| <b>Journal Scope:</b> | Engineering  |
| <b>Country:</b>       | Switzerland  |
| <b>H-Index:</b>       | 45   |
| <b>SJR:</b>           | 0.605  |
| <b>Quartile:</b>      | Architecture (Q1); Building and Construction (Q2); Civil and Structural Engineering (Q2) |

**BUILDINGS**

Journal Impact Factor™

|       |           |
|-------|-----------|
| 2021  | Five Year |
| 3.324 | 3.354     |

| JCR Category   | Category Rank | Category Quartile |
|--|---------------|-------------------|
| CONSTRUCTION & BUILDING TECHNOLOGY<br><i>in SCIE edition</i> | 28/68         | Q2                |
| ENGINEERING, CIVIL<br><i>in SCIE edition</i>                 | 58/138        | Q2                |

Source: Journal Citation Reports 2021. [Learn more](#)

Journal Citation Indicator™

|      |      |
|------|------|
| 2021 | 2020 |
| 0.66 | 0.68 |

| JCI Category   | Category Rank | Category Quartile |
|--|---------------|-------------------|
| CONSTRUCTION & BUILDING TECHNOLOGY<br><i>in SCIE edition</i> | 32/89         | Q2                |
| ENGINEERING, CIVIL<br><i>in SCIE edition</i>                 | 72/175        | Q2                |

**Rank by Journal Impact Factor**

Journals within a category are sorted in descending order by Journal Impact Factor (JIF) resulting in the Category Ranking below. A separate rank is shown for each category in which the journal is listed in JCR. Data for the most recent year is presented at the top of the list, with other years shown in reverse chronological order. [Learn more](#)

| EDITION  | Science Citation Index Expanded (SCIE) | EDITION      | Science Citation Index Expanded (SCIE) |          |          |              |                |
|----------|--|--------------|--|----------|----------|--------------|----------------|
| CATEGORY | CONSTRUCTION & BUILDING TECHNOLOGY     | CATEGORY     | ENGINEERING, CIVIL                     |          |          |              |                |
|          | <b>23/68</b>                           |              | <b>46/139</b>                          |          |          |              |                |
| JCR YEAR | JIF RANK                               | JIF QUARTILE | JIF PERCENTILE                         | JCR YEAR | JIF RANK | JIF QUARTILE | JIF PERCENTILE |
| 2022     | 23/68                                  | Q2           | 66.9                                   | 2022     | 46/139   | Q2           | 67.3           |
| 2021     | 28/68                                  | Q2           | 59.56                                  | 2021     | 58/138   | Q2           | 58.33          |
| 2020     | 32/67                                  | Q2           | 52.99                                  | 2020     | 61/137   | Q2           | 55.84          |

Figure A1. Journal Citation Reports.

## **APPENDIX 3**

### **Articles front page**

## Articles front page



Article

### Utilization of BIM in Steel Building Projects: A Systematic Literature Review

José Ignacio Avendaño<sup>1</sup>, Sisi Zlatanova<sup>2</sup>, Alberto Domingo<sup>1</sup>, Pedro Pérez<sup>3</sup> and Christian Correa<sup>3,\*</sup>

- <sup>1</sup> Department of Construction Engineering and Civil Engineering Projects, University Polytechnic of Valencia, 46003 Valencia, Spain; jo.ignacio.a@gmail.com (J.I.A.); adoming@cst.upv.es (A.D.)
- <sup>2</sup> GRID, School of Built Environment, University of New South Wales, Sydney 2052, Australia; s.zlatanova@unsw.edu.au
- <sup>3</sup> Department of Civil Works, Faculty of Engineering Sciences, University Católica del Maule, Talca 3480094, Chile; pedro.perez@alu.ucm.cl
- \* Correspondence: clcorrea@ucm.cl

**Abstract:** This research aims to bridge the information gap pertaining to the utilization of building information modeling (BIM) in steel building projects. Therefore, a systematic literature review (SLR) was conducted to synthesize the available uses. This research involved three phases—planning, execution, and reporting—according to the PRISMA guide, which includes the main aspects of identification, screening, and eligibility. As a result of the SLR, it is evident how and where BIM facilitates steel building projects, which were grouped into three different categories according to their main BIM topics. One of the uses that stands out as a common denominator across the different processes is “early integration”. Early integration allows for optimization of the design based on existing resources, directly affecting the cost and time of steel building projects in a positive manner.

**Keywords:** building information modeling (BIM); steel project life cycle; project management; communication in steel construction projects



**Citation:** Avendaño, J.I.; Zlatanova, S.; Domingo, A.; Pérez, P.; Correa, C. Utilization of BIM in Steel Building Projects: A Systematic Literature Review. *Buildings* 2022, 12, 713. <https://doi.org/10.3390/buildings12060713>

Academic Editor: Morten Gjerdet

Received: 13 April 2022  
Accepted: 20 May 2022  
Published: 25 May 2022

**Publisher's Note:** MDPI stays neutral with regard to jurisdictional claims in published maps and institutional affiliations.



Copyright: © 2022 by the authors. Licensee MDPI, Basel, Switzerland. This article is an open access article distributed under the terms and conditions of the Creative Commons Attribution (CC BY) license (<https://creativecommons.org/licenses/by/4.0/>).

#### 1. Introduction

Steel is an essential material for the construction industry; as a result, its consumption and production per capita have grown considerably, owing to population growth and increasing demands for industrialization in developing countries, among other factors [1]. Steel offers certain advantages over other construction materials, such as low weight, adequate structural behaviors, a high degree of prefabrication, and increased construction speed [2,3]. Steel construction can be divided into two categories: (1) “concrete building,” which is realized using concrete and steel bars (reinforced concrete); and (2) “steel building,” where steel is considered the primary construction material [4]. Steel construction involves a wide variety of projects, such as industrial, housing, and non-housing projects, which have lower costs and greater social values than those associated with reinforced concrete [2,3]. A steel building project comprises factory-made components or units transported and assembled in the shop or on-site [5]. The work phases involved are (1) planning, (2) design, (3) fabrication, (4) transport, (5) construction planning, and (6) erection of the structure [5,6]. The efficient completion of these steps maximizes the benefits of working with steel [7]. However, the use of steel as a construction material has increased the complexity of projects, particularly in terms of information management, because it is imperative to ensure quality and timely information for the different actors involved in the workflow. Thus, redoing processes can be avoided, and, consequently, the associated costs and construction time can be reduced. The inefficient use of information results in fragmentation during construction [8]. To cope with such fragmentation, it is necessary to include building information technologies that facilitate collaboration between the different actors involved in the building life cycle [9].

Figure A2. Article 1 front page.



Article

# Integration of BIM in Steel Building Projects (BIM-DFE): A Delphi Survey

José Ignacio Avendaño <sup>1</sup>, Sisi Zlatanova <sup>2</sup>, Pedro Pérez <sup>3</sup>, Alberto Domingo <sup>1</sup> and Christian Correa <sup>3,\*</sup>

<sup>1</sup> Department of Construction Engineering and Civil Engineering Projects, University Polytechnic of Valencia, 46003 Valencia, Spain

<sup>2</sup> GRID, School of Built Environment, University of New South Wales, Sydney 2052, Australia

<sup>3</sup> Department of Civil Works, Faculty of Engineering Sciences, University Católica del Maule, Talca 3480094, Chile

\* Correspondence: ccorrea@ucm.cl

**Abstract:** This study aims to design a BIM integration model for steel building projects (BIM-DFE). It was developed in the following three phases: (i) theoretical phase, (ii) validation phase, and (iii) statistical analysis for the theoretical phase. A literature review was conducted to study the applications of BIM in steel building projects and to develop an integrated BIM process map for the construction lifecycle of steel buildings. Subsequently, in the validation phase, 32 participants were invited to complete a two-round Delphi questionnaire to validate the BIM-DFE proposal. The participants were classified according to their knowledge level (skilled or expert). Based on the literature review, a process map that integrates BIM in different phases of a steel building project was created. In the first round of the Delphi questionnaire for the validation phase, the various groups studied (skilled vs. expert) were in moderate agreement with the BIM-DFE proposal; however, after the second round, this agreement became better. Therefore, this study contributes to the current body of knowledge by providing a BIM integration model to improve the management of steel building projects as defined by critical stakeholders in the steel industry. In addition, a real-time case is presented to elucidate a part of the research contribution.

**Keywords:** building information modeling (BIM); steel project life cycle; Delphi; integration model; steel buildings



**Citation:** Avendaño, J.I.; Zlatanova, S.; Pérez, P.; Domingo, A.; Correa, C. Integration of BIM in Steel Building Projects (BIM-DFE): A Delphi Survey. *Buildings* **2022**, *12*, 1439. <https://doi.org/10.3390/buildings12091439>

Academic Editor: Francisco López Almansa

Received: 4 August 2022

Accepted: 8 September 2022

Published: 13 September 2022

**Publisher's Note:** MDPI stays neutral with regard to jurisdictional claims in published maps and institutional affiliations.



**Copyright:** © 2022 by the authors. Licensee MDPI, Basel, Switzerland. This article is an open access article distributed under the terms and conditions of the Creative Commons Attribution (CC BY) license (<https://creativecommons.org/licenses/by/4.0/>).

## 1. Introduction

The construction industry, which includes engineering and construction activities, is a fundamental part of the global economy and accounts for approximately six percent of the total gross domestic product, which is equivalent to approximately 10 trillion USD annually [1,2]. Recently, the conventional construction industry encountered a technological revolution that mitigates the classic errors of this industry, such as time delays, cost, and construction quality. An important factor in this technological revolution is building information modeling (BIM), which was developed as a solution to mitigate the errors of traditional construction [3]. BIM is a series of activities that can improve deliverables in the design and construction process [4–6] and is intended to optimize the information transfer processes, which is vital for fluid design and construction. Examples of how BIM can benefit the stakeholders in this industry include the following:

**Principal/owner:** Control of project expectations from an economic and visual perspective.



**Engineers/Designers:** Designers can improve the long-term relationships with various stakeholders owing to a better understanding of the different threads for the materialization of construction projects.

**Builder/executing engineer:** Permit to contribute their knowledge during the design process or update the model during different stages of construction, thus improving

**Figure A3.** Article 2 front page.

Article

# Building Information Modeling in Steel Building Projects Following BIM-DFE Methodology: A Case Study

José Ignacio Avendaño <sup>1,\*</sup> , Alberto Domingo <sup>1</sup> and Sisi Zlatanova <sup>2</sup> 

<sup>1</sup> Department of Construction Engineering and Civil Engineering Projects, University Polytechnic of Valencia, 46003 Valencia, Spain; adoming@cst.upv.es

<sup>2</sup> GRID—Geospatial Research Innovation Development, School of Built Environment, University of New South Wales, Sydney 2052, Australia; s.zlatanova@unsw.edu.au

\* Correspondence: jo.ignacio.a@gmail.com

**Abstract:** Construction is a key industry that significantly contributes to the global gross domestic product and generates substantial revenues. However, it faces challenges such as errors and high costs. The aim of this study is to demonstrate the methodology of applying building information modeling integration for the design, fabrication, and erection of steel buildings, called BIM-DFE, in a real-world scenario. This is the first study in which this methodology is applied in an actual case. Two steel building projects with similar design typologies were selected. The first project was executed using computer-aided design and traditional BIM techniques during the planning, design, and fabrication phases. The BIM-DFE methodology was applied to the same phases in the second project. The results of the two projects were compared quantitatively. The experiments suggest that the application of the BIM-DFE methodology reduced the development time in the planning phase, incorporated manufacturing constraints in the design phase, and significantly reduced assembly times in the fabrication phase. This study confirmed the feasibility of applying BIM-DFE methodology in an actual case scenario, which is the result of collaboration between the scientific community and the industry in steel building projects.

**Keywords:** building information modeling (BIM); steel building projects; integration model



**Citation:** Avendaño, J.I.; Domingo, A.; Zlatanova, S. Building Information Modeling in Steel Building Projects Following BIM-DFE Methodology: A Case Study. *Buildings* **2023**, *13*, 2137. <https://doi.org/10.3390/buildings13092137>

Academic Editor: Amos Darko

Received: 15 July 2023  
Revised: 17 August 2023  
Accepted: 21 August 2023  
Published: 23 August 2023



**Copyright:** © 2023 by the authors. Licensee MDPI, Basel, Switzerland. This article is an open access article distributed under the terms and conditions of the Creative Commons Attribution (CC BY) license (<https://creativecommons.org/licenses/by/4.0/>).

## 1. Introduction

Construction is a key industry that significantly contributes to the global gross domestic product (GDP), accounting for approximately 6% of the global GDP and generating annual revenues of approximately \$10 trillion [1,2]. However, the productivity of the construction industry lags compared with that of other sectors [3]. Historically, the industry has been prone to errors, high costs, and interference [4–6].

Steel structures have recently gained increased attention owing to their strength, durability, and efficiency [7,8]. However, the lack of coordination among the different parties involved in construction projects has become a common problem that causes delays, cost overruns, and low project quality [1,4,6]. This problem is particularly severe in steel construction, where supply chain fragmentation and the lack of communication between engineers, fabricators, designers, and contractors have led to problems in planning, design, fabrication, transportation, and erection [1,9–12].

A steel construction project consists of several phases, ranging from material and fabricator selection to the erection and finishing of the structure [1,13,14]. As the use of steel in construction increases, the complexity of projects also increases, especially in terms of information management [1,12,15,16]. The quality and timeliness of information in different stages of the workflow must be ensured to avoid the repetition of processes and interference and reduce the associated costs and construction time [12,16]. The inefficient use of information causes fragmentation of a steel project lifecycle. Therefore, information

**Figure A4.** Article 3 front page.