



UNIVERSITAT POLITÈCNICA
DE VALÈNCIA

HYDRAULIC ENGINEERING AND ENVIRONMENT DEPARTMENT

Ph. D. in Water and Environmental Engineering

Ph.D. Thesis

OPTIMAL DESIGN OF URBAN SEWER SYSTEMS

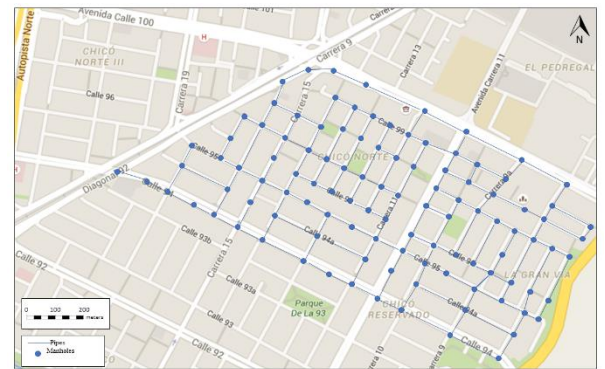

Author

Juan Saldarriaga

Thesis supervisor

Professor Pedro L. Iglesias Rey

December 2023, Valencia, Spain



UNIVERSITAT
POLITÈCNICA
DE VALÈNCIA

HYDRAULIC ENGINEERING AND ENVIRONMENT DEPARTMENT

Ph. D. in Water and Environmental Engineering

Ph.D. Thesis

OPTIMAL DESIGN OF URBAN SEWER SYSTEMS

Author:

Juan Saldarriaga

Thesis supervisor:

Professor Pedro L. Iglesias Rey

December 2023, Valencia, Spain

When you put together the science of the motions of water,
remember to include under each proposition its application, in
order that this science may not be useless.

Leonardo Da Vinci

There is no philosophy which is not founded upon knowledge
of the phenomena, but to get any profit from this knowledge
it is absolutely necessary to be a mathematician.

Daniel Bernoulli

Dedication

A Carolina, Juliana, Alejandro y Catalina,
mis compañeros de viaje en esta vida. Sin
su apoyo esta tesis no hubiese sido posible.
Con todo mi amor.

To Carolina, Juliana, Alejandro, and Catalina
my travel companions in this life. Without
their support this thesis would not have
been possible. With all my love.

Acknowledgments

The present Ph.D. thesis has been the result of the guidance of Professor Pedro Luis Iglesias Rey of Universitat Politècnica de València. I would like to thank him for his academic and administrative support during the development of this thesis, and for his sincere and profound interest in developing new knowledge in hydraulic engineering. It was his idea to engage me in pursuing a Ph.D. degree so late in my academic life. He believed in my knowledge and abilities to develop independent research, and for that I am in debt.

Dr. Francisco Javier Martínez Solano has known about my research in urban drainage systems for several years and has helped me with ideas and advice. I am very grateful for his acceptance to be part of the thesis tribunal. Professor Martínez and all the professors from the Hydraulic Engineering and Environment Department of Universitat Politècnica de València, specifically those belonging to the Ph.D. in Water and Environmental Engineering, always showed their support to the development of this thesis. Each time I visited Valencia I was welcomed by them, their companionship made me feel like I was at home.

I also extend my gratitude to Professor Andrés Medaglia, from the Department of Industrial Engineering at Universidad de los Andes, for sharing his knowledge and that of his team on Optimization, through his students in the Center for Optimization and Applied Probability, whose work is outstanding. It was through Professor Medaglia that I learned about the importance of applied mathematics; a necessity as stated by Daniel Bernoulli. This made it possible to obtain an optimized design of an urban drainage network.

Professors Dragan Savic, Steven Buchberger, Orazio Giustolisi, Bruno Brunone, Dominic Boccelli, Martin Lambert, Jakobus Van Zyl, Javier Martínez Solano, Amparo López Jiménez, and my former student and now Professor Jessica Bohórquez, I thank all of you for agreeing to be my jurors and, as a result, for helping me contribute to, in the words of Leonardo Da Vinci, the science of the motions of water.

Finally, I must also thank my current and former students at the Water Supply and Sewerage Systems Research Center (Centro de Investigaciones en Acueductos y Alcantarillados, CIACUA) at Universidad de los Andes in Bogotá, Colombia. They have been a source of inspiration to address challenges related to urban hydraulics. It has been an honor to learn alongside them, and from them, throughout these years, and to be their advisor. Listing all of them here would be impossible.

Abstract

Urban drainage systems, also known as sewer systems, have the purpose of draining both rainwater and wastewater from our cities. These systems are one of the different civil infrastructures that allow the proper functioning of modern cities. Stormwater systems are responsible for moving the rainwater that falls in the city safely and in a reasonable time, without allowing flooding, to the natural receiving bodies located downstream. On the other hand, wastewater systems are designed to collect sewage from domestic, industrial, and commercial sources and transport it safely to a wastewater treatment plant before sending it definitively to a receiving body or to a reuse system, if available. Both types of sewer systems, but particularly wastewater systems, have an extensive impact on public health with implications for the viability of a city.

The existing urban drainage infrastructure presents new challenges to urban hydraulic engineering. On the one hand, stormwater systems, in addition to being subjected to aging problems with deterioration of materials and soil settlement, are facing serious problems caused by climate change. In many cities this phenomenon is implying radical changes in urban hydrology; intensities and frequencies of rainfall events are increasing so that the existing systems, which were designed for different hydrological conditions, are running out of capacity, increasing the frequency of urban flooding with its consequences on safety and human health. On the other hand, wastewater systems also present engineering challenges due to problems of increasing population density in cities, lack of resilience to external events such as earthquakes, and water quality problems in receiving waters within urban areas, in groundwater, and natural water currents. These systems are also affected by the deterioration of materials and soil settlement problems.

Now, a different problem is the non-existence of urban drainage systems in many cities of the world, particularly in those located in developing countries. In the vast majority of these cases, the lack of sewers is caused by the high cost of this infrastructure, making its construction unfeasible for local governments. In addition, the growth of urban areas in these countries exacerbates the problem. Not only does the necessary infrastructure become larger and more complex, but the public health problems associated with the lack of environmental sanitation increase. Therefore, the challenge for modern urban water engineering is to achieve greater access to this essential service. One way to solve this is by lowering the construction and operating costs of drainage systems, making them financially viable while maintaining their resilience and safety. This will help meet Sustainable Development Goal No. 6 Clean Water and Sanitation.

Considering the above, the aim of this thesis was to propose a methodology that would lead to the minimum cost design of conventional sewer networks, maintaining their resilience and ease of operation, while complying with all the hydraulic, constructive, and operational restrictions that, according to international empirical experience, are appropriate to guarantee a correct behavior of the drainage system.

The optimized design of a sewer network is composed of two mutually dependent parts: the layout selection and the hydraulic design. In this thesis, the two problems were solved separately from a mathematical point of view, maintaining their interdependence through an iterative process. For a given layout, which could be random for a first iteration, the hydraulic design problem was solved as a

shortest path problem using the Bellman-Ford algorithm that guarantees the global minimum cost for that layout. The problem is model as a directed graph in which the nodes represent the combination of diameters and invert elevations at every manhole, and the arcs represent the diameter and upstream and downstream invert elevation of a specific pipe. As a result, the optimization process of this part gives the diameters and slopes of each pipe and the corresponding filling ratio, for the design flow rate of each pipe, complying with all the constraints given by the designer. With these results a cost equation can be obtained for each pipe as a function of the diameter and the required excavation volume, which is the input for the layout selection process in the next iteration.

The original process of choosing the new layout uses the mentioned cost equation to perform a linear regression between the cost and the flow rate of each pipe. The resulting coefficients of the linear regression are used to feedback the objective function of the layout selection model, which uses Mixed Integer Programming. With this actualization of the objective function, a new layout is selected. With this, the entire process of calculating a new hydraulic design and layout is repeated until the total costs of two successive iterations are very similar. The design process proved to be computationally expensive, especially for large sewer networks with a number of pipes above 500.

In order to reduce this computational time, in a second stage of the thesis, the general process was changed to avoid starting from a random layout. A new methodology was established to choose the initial layout based on understanding the topological aspects of the terrain and the layout of streets (geometry of the problem) and the dissipated power corresponding to the flow rate multiplied by the length and slope of each pipe (physics of the problem). In this way it was possible to reduce the iterations of the general process to no more than 2 or 3, with which the computational cost was substantially reduced depending only on the efficiency of the Bellman-Ford algorithm. Subsequently, the way was traced to introduce other typical structures of a sewer network using drop manholes as an example. This means that the optimized design methodology proposed in the thesis can include any structure of an urban drainage system. Finally, an analysis of the resilience of the optimized designs was performed.

The methodology and the corresponding computer programs were tested on benchmark urban drainage networks reported in the technical literature, obtaining the lowest costs reported to date. A new benchmark network was also introduced based on a real network that is part of the stormwater of the city of Bogota, Colombia. This network is described in Appendix 2 of this document. Thus, as a result of the thesis, it can be stated that the problem of optimized design of a sewer network has been solved.

As this is a Ph.D. Thesis based on a compendium of publications, it is endorsed on 4 papers already published in journals of the International Scientific Index ISI, all of them Q1/Q2, and 3 papers already sent. That compendium forms the main body of this document.

Resumen

Los sistemas de drenaje urbano, también conocidos como sistemas de alcantarillado, tienen el propósito de drenar tanto las aguas lluvias como las aguas residuales de nuestras ciudades. Estos sistemas son una de las diferentes infraestructuras civiles que permiten el correcto funcionamiento de las ciudades actuales. Los sistemas de alcantarillados pluviales se encargan de mover las aguas lluvias que caen en la ciudad en forma segura y en un tiempo razonable, sin permitir inundaciones, hacia los cuerpos receptores naturales localizados aguas abajo. Los sistemas de alcantarillado sanitario, por otra parte, tienen el objetivo de recolectar las aguas servidas, de origen domiciliario, industrial y comercial, y transportarlas en forma segura hacia una planta de tratamiento de aguas residuales antes de enviarlas en forma definitiva hacia un cuerpo receptor o hacia un sistema de reuso, en caso de que este exista. Ambos tipos de alcantarillado, pero particularmente los sanitarios, tienen un profundo impacto sobre la salud pública con implicaciones sobre la viabilidad de una ciudad.

La infraestructura de drenaje urbano existente plantea nuevos retos a la ingeniería hidráulica urbana. Por un lado, los sistemas de drenaje de aguas lluvias, además de verse sometidos a problemas de envejecimiento con deterioros de materiales y asentamientos de suelos, se están enfrentando a serios problemas causados por el Cambio Climático. En muchas ciudades este fenómeno está implicando cambios radicales en la hidrología urbana; en muchas ciudades las intensidades y frecuencias de los eventos de lluvia están aumentando con lo cual los sistemas existentes, que fueron diseñados para hidrologías diferentes, se quedan sin capacidad aumentando la frecuencia de las inundaciones urbanas con sus consecuencias sobre la seguridad y salud humana. Por otro lado, los sistemas sanitarios también presentan retos a la ingeniería por problemas de aumento de la densidad poblacional de las ciudades, la falta de resiliencia ante eventos externos como sismos, y a problemas de calidad de agua en los cuerpos receptores al interior de las zonas urbanas, en las aguas freáticas y las corrientes naturales de agua. Estos sistemas también se ven afectados por el deterioro de los materiales y los problemas de asentamiento de los suelos.

Ahora, un problema diferente es la no existencia de sistemas de drenaje urbano en muchas ciudades de nuestro mundo, particularmente en aquellas localizadas en países en vías de desarrollo. En la gran mayoría de esos casos, esa falta de alcantarillados es causada por el alto costo de esa infraestructura cuya construcción hace inviable para los gobiernos locales. Además, el crecimiento de las zonas urbanas en esos países agrava el problema. No solamente la infraestructura necesaria se hace más grande y compleja, sino que aumentan los problemas de salud pública asociados con la falta de sanidad ambiental. Por consiguiente, el reto para la ingeniería hidráulica urbana moderna es lograr un mayor acceso a ese servicio esencial. Una de las formas de resolverlo es bajando los costos de construcción y operación de los sistemas de drenaje, haciéndolos financieramente viables a la vez que se mantienen su resiliencia y seguridad. De esta manera se ayudará a cumplir con el Objetivo de Desarrollo Sostenible No. 6 Agua Limpia y Saneamiento.

Teniendo en cuenta lo anterior, el objetivo de esta tesis fue proponer una metodología que llevara al diseño de mínimo costo de redes de alcantarillado convencionales, manteniendo su resiliencia y facilidad de operación, a la vez que se cumplieran todas las restricciones hidráulicas, constructivas y de operación que, de acuerdo con la experiencia empírica internacional, son las apropiadas para garantizar un correcto comportamiento del sistema de drenaje.

El diseño optimizado de una red de alcantarillado está compuesto por dos partes mutuamente dependientes: la selección del árbol y el diseño hidráulico. En esta tesis se resolvieron los dos problemas en forma separada desde el punto de vista matemático, manteniendo su interdependencia a través de un proceso iterativo. Para un árbol dado, que podría ser aleatorio para una primera iteración, el problema del diseño hidráulico se resolvió como un problema de ruta más corta usando el algoritmo de Bellman-Ford que garantiza el costo mínimo global para ese árbol. El problema recorre un grafo dirigido en el que los nodos representan las combinaciones existentes de diámetros y profundidades de excavación y los arcos representan las conexiones factibles entre nodos. Como resultado el proceso de optimización de esta parte da los diámetros y pendientes de cada tubería y la relación de llenado correspondiente, para el caudal de diseño de cada tubo, cumpliendo con todas las restricciones dadas por el diseñador. Con estos resultados se puede obtener una ecuación de costos de cada tubo como función del diámetro y el volumen de excavación necesario, la cual es el insumo de entrada para el proceso de selección del árbol en la siguiente iteración.

El proceso original de escogencia del nuevo árbol usa la anterior ecuación y la convierte en una en la que el costo es función del caudal y de la dirección de flujo. Usando un modelo de Programación Entera Mixta, se llega a un nuevo árbol. Con este se repite todo el proceso de cálculo de un nuevo diseño hidráulico y un nuevo árbol, el cual se detiene cuando en dos iteraciones sucesivas los costos totales sean muy parecidos. El proceso de diseño probó ser costoso en tiempo computacional, especialmente para redes de drenaje grandes, con un número de tubos por encima de los 500.

Con el fin de disminuir ese tiempo computacional, en una segunda etapa de la tesis se cambió el proceso general para evitar que este partiera de un árbol aleatorio. Se estableció una nueva rutina para escoger el árbol inicial basada en entender los aspectos topológicos del terreno y del trazado de calles y carreras (geometría del problema) y la potencia disipada correspondiente al caudal multiplicado por la longitud y la pendiente de cada tubería (física del problema). De esta forma se logró reducir las iteraciones del proceso general a no más de 2 o 3, con lo cual el costo computacional se redujo sustancialmente dependiendo únicamente de la eficiencia del algoritmo de Bellman-Ford. Posteriormente se trazó el camino para introducir otras estructuras típicas de una red de alcantarillado usando como ejemplo las cámaras de caída. Esto significa que la metodología de diseño optimizado propuesta en la tesis puede incluir cualquier estructura de un sistema de drenaje urbano. Finalmente se hizo un análisis de la resiliencia de los diseños optimizados.

La metodología y los correspondientes programas de computador fueron probados en las redes patrón (benchmarks) de redes de drenaje urbano reportadas en la literatura técnica, obteniendo los menores costos reportados hasta ahora. Igualmente se introdujo una nueva red patrón (benchmark) basada en una red real que forma parte del sistema de drenaje de aguas lluvias de la ciudad de Bogotá, Colombia. Esta red se encuentra descrita en el Apéndice 2 de este documento. De esta forma se puede afirmar, como resultado de la tesis, que el problema del diseño optimizado de una red de alcantarillado es un problema resuelto.

Como esta es una tesis basada en un compendio de publicaciones, incluye 4 artículos ya publicados en revistas periódicas del International Scientific Index ISI, todas ellas Q1/Q2, y 3 artículos adicionales ya enviados. Ese compendio forma el cuerpo principal de este documento.

Resum

Els sistemes de drenatge urbà, també coneguts com a sistemes de clavegueram, tenen el propòsit de drenar tant les aigües pluges com les aigües residuals de les nostres ciutats. Aquests sistemes són una de les diferents infraestructures civils que permeten el correcte funcionament de les ciutats actuals. Els sistemes de claveguerams pluvials s'encarreguen de moure les aigües pluges que cauen a la ciutat en forma segura i en un temps raonable, sense permetre inundacions, cap als cossos receptors naturals localitzats aigües avall. Els sistemes de clavegueram sanitari, d'altra banda, tenen l'objectiu de recol·lectar les aigües servides, d'origen domiciliari, industrial i comercial, i transportar-les en forma segura cap a una planta de tractament d'aigües residuals abans d'enviar-les en forma definitiva cap a un cos receptor o cap a un sistema de reuse, en cas que aquest existisca. Tots dos tipus de clavegueram, però particularment els sanitaris, tenen un profund impacte sobre la salut pública amb implicacions sobre la viabilitat d'una ciutat.

La infraestructura de drenatge urbà existent planteja nous reptes a l'enginyeria hidràulica urbana. D'una banda, els sistemes de drenatge d'aigües pluges, a més de veure's sotmesos a problemes d'envelliment amb deterioracions de materials i assentaments de sòls, s'estan enfrontant a seriosos problemes causats pel Canvi Climàtic. En moltes ciutats aquest fenomen està implicant canvis radicals en la hidrologia urbana; en moltes ciutats les intensitats i freqüències dels esdeveniments de pluja estan augmentant amb la qual cosa els sistemes existents, que van ser dissenyats per a hidrologies diferents, es queden sense capacitat augmentant la freqüència de les inundacions urbanes amb les seues conseqüències sobre la seguretat i salut humana. D'altra banda, els sistemes sanitaris també presenten reptes a l'enginyeria per problemes d'augment de la densitat poblacional de les ciutats, la falta de resiliència davant esdeveniments externs com a sismes, i a problemes de qualitat d'aigua en els cossos receptors a l'interior de les zones urbanes, en les aigües freàtiques i els corrents naturals d'aigua. Aquests sistemes també es veuen afectats per la deterioració dels materials i els problemes d'assentament dels sòls.

Ara, un problema diferent és la no existència de sistemes de drenatge urbà en moltes ciutats del nostre món, particularment en aquelles localitzades en països en vies de desenvolupament. En la gran majoria d'aqueixos casos, aqueixa falta de claveguerams és causada per l'alt cost d'aqueixa infraestructura la construcció de la qual fa inviable per als governs locals. A més, el creixement de les zones urbanes en aqueixos països agreuja el problema. No solament la infraestructura necessària es fa més gran i complexa, sinó que augmenten els problemes de salut pública associats amb la falta de sanitat ambiental. Per consegüent, el repte per a l'enginyeria hidràulica urbana moderna és aconseguir un major accés a aqueix servei essencial. Una de les maneres de resoldre-ho és baixant els costos de construcció i operació dels sistemes de drenatge, fent-los financerament viables alhora que es mantenen la seua resiliència i seguretat. D'aquesta manera s'ajudarà a complir amb l'Objectiu de Desenvolupament Sostenible No. 6 Aigua Neta i Sanejament.

Tenint en compte l'anterior, l'objectiu d'aquesta tesi va ser proposar una metodologia que portara al disseny de mínim cost de xarxes de clavegueram convencionals, mantenint la seua resiliència i facilitat d'operació, alhora que es compliren totes les restriccions hidràuliques, constructives i d'operació que, d'acord amb l'experiència empírica internacional, són les apropiades per a garantir un correcte comportament del sistema de drenatge.

El disseny optimitzat d'una xarxa de clavegueram està compost per dues parts mútuament dependents: la selecció de l'arbre i el disseny hidràulic. En aquesta tesi es van resoldre els dos problemes en forma separada des del punt de vista matemàtic, mantenint la seua interdependència a través d'un procés iteratiu. Per a un arbre donat, que podria ser aleatori per a una primera iteració, el problema del disseny hidràulic es va resoldre com un problema de ruta més curta usant l'algorisme de Bellman-Ford que garanteix el cost mínim global per a aqueix arbre. El problema recorre un graf dirigit en el qual els nodes representen les combinacions existents de diàmetres i profunditats d'excavació i els arcs representen les connexions factibles entre nodes. Com a resultat el procés d'optimització d'aquesta part dona els diàmetres i pendents de cada canonada i la relació d'ompliment corresponent, per al cabal de disseny de cada tub, complint amb totes les restriccions donades pel dissenyador. Amb aquests resultats es pot obtenir una equació de costos de cada tub com a funció del diàmetre i el volum d'excavació necessari, la qual és l'input d'entrada per al procés de selecció de l'arbre en la següent iteració.

El procés original de escogència del nou arbre usa l'anterior equació i la converteix en una en la qual el cost és funció del cabal i de la direcció de flux. Usant un model de Programació Sencera Mixta, s'arriba a un nou arbre. Amb aquest es repeteix tot el procés de càlcul d'un nou disseny hidràulic i un nou arbre, el qual es deté quan en dues iteracions successives els costos totals siguen molt semblants. El procés de disseny va provar ser costós en temps computacional, especialment per a xarxes de drenatge grans, amb un nombre de tubs per damunt dels 500.

Amb la finalitat de disminuir aqueix temps computacional, en una segona etapa de la tesi es va canviar el procés general per a evitar que aquest partira d'un arbre aleatori. Es va establir una nova rutina per a triar l'arbre inicial basada a entendre els aspectes topològics del terreny i del traçat de carrers i carreres (geometria del problema) i la potència dissipada corresponent al cabal multiplicat per la longitud i el pendent de cada canonada (física del problema). D'aquesta manera es va aconseguir reduir les iteracions del procés general a no més de 2 o 3, amb la qual cosa el cost computacional es va reduir substancialment depenent únicament de l'eficiència de l'algorisme de Bellman-Ford. Posteriorment es va traçar el camí per a introduir altres estructures típiques d'una xarxa de clavegueram usant com a exemple les cambres de caiguda. Això significa que la metodologia de disseny optimitzat proposta en la tesi pot incloure qualsevol estructura d'un sistema de drenatge urbà. Finalment es va fer una anàlisi de la resiliència dels dissenys optimitzats.

La metodologia i els corresponents programes de computador van ser provats en les xarxes patró (benchmarks) de xarxes de drenatge urbà reportades en la literatura tècnica, obtenint els menors costos reportats fins ara. Igualment es va introduir una nova xarxa patró (benchmark) basada en una xarxa real que forma part del sistema de drenatge d'aigües pluges de la ciutat de Bogotà, Colòmbia. Aquesta xarxa sen troba descrita en l'Apèndix 2 d'aquest document. D'aquesta manera es pot afirmar, com a resultat de la tesi, que el problema del disseny optimitzat d'una xarxa de clavegueram és un problema resolt.

En tractar-se d'una tesi doctoral basada en un compendi de publicacions, està avalada per 4 treballs ja publicats en publicacions periòdiques de l'Índex Científic Internacional ISI, tots ells Q1/Q2, i 3 treballs ja enviats. Aqueix compendi constitueix el cos principal d'aquest document.

About this document

The present document contains the final report of a Ph.D. Thesis based on a series of papers published in International Scientific Index ISI journals Q1/Q2 in the field of urban drainage, specifically related to the optimal design of sewer networks. It has 9 chapters and two appendices.

Chapter 1 contains the motivation, and the research question. It also shows some international statistics related to the lack of basic sanitation and storm water infrastructure worldwide. This deficit makes it impossible to achieve U.N. Sustainable Development Objective No. 6 “Potable water and basic sanitation for all”.

Chapter 2 introduces the sewer network optimal design. It describes the problem, the information and data needed, the hydraulic, construction and commercial constraints, and the design results. Then, it explores the size of the solution space, and the cost equations needed to describe the objective equation, i.e., the cost that must be minimized.

Chapters 3 to 6, in chronological order, present the 4 papers already published. The first one, Chapter 3, describes the mathematical framework for the optimization methodology, dividing the process into the network layout selection and the hydraulic design, using a minimum cost path and a graph frame. Chapter 4 introduces the use of topographical, geometrical, and power concepts to accelerate the optimization algorithm by predetermining the network layout. Chapter 5 adds a new component on the sewer network; it describes how to include drop manholes in the graph and in the methodology, as a first example of how to deal with any other component of an urban drainage system. Finally, Chapter 6 analyses the relation between an optimal design and the resilience on a sewer network.

Chapter 7 is dedicated to making discussions on the scope and results of this thesis. It includes a general discussion on the optimal design of urban drainage systems and the cost of urban infrastructure. There are also discussions on current and future design constraints, both hydraulic and constructive, and their relevance in the optimal design of sewer systems. Finally, the proposed methodology and the obtained results are discussed.

Chapter 8 contains the general and specific conclusions of this doctoral thesis as well as the recommendations. It describes the papers already published in ISI journals and international technical and scientific congresses and seminars.

Chapter 9 deals with the future works related to this thesis. It describes three other papers already submitted to ISI journals, under reviewing processes at the time of writing this document. Also describes some postgraduate and continuing education courses under development as results of the design process developed for the optimal design of urban drainage infrastructure. Finally, it shows some possible association with Colombian Government institutions to apply the new methodology to the design of sewer systems in lower income communities.

Appendix 1 contains the references of all chapters; the references are divided per chapter to facilitate the reading process. And Appendix 2 provides additional information on the Chicó network, located in Bogotá, Colombia, and used in this thesis. Additionally, it includes the DOI to access online information about the network and the results obtained from the optimized design.

Contents

Dedication	III
Acknowledgments.....	V
Abstract.....	VII
Resumen	IX
Resum.....	XI
About this document	XIII
1. Introduction	1
Preamble	1
1.1 Motivation: Need for Optimal Sewer Systems	1
1.2 Current Needs	2
1.2.1 Wastewater	3
1.2.2 Stormwater	6
2. Sewer Networks Design (SND)	9
Preamble	9
2.1 SND Description	10
2.2 Problem Definition	10
2.3 Problem Size.....	14
2.3.1 Series of Pipes	15
2.3.2 Sewer networks.....	16
2.3.3 Comparison and Growth.....	16
2.4 Cost Equations.....	17
2.5 Constraints	20
3. Sewer Network Layout Selection and Hydraulic Design Using a Mathematical Optimization Framework	23
Preamble	23
3.1 Introduction	23
3.2 Problem Statement and Definitions.....	26
3.2.1 Layout Selection	27
3.2.2 Hydraulic Design.....	28
3.3 Methodology.....	28
3.3.1 Layout Selection Model.....	29
3.3.2 Layout Representation as a Tree-Like Directed Graph	31

3.3.3	Hydraulic Design Model and Solution Approach	31
3.3.4	Iterative Scheme	34
3.3.5	Software and Data.....	36
3.3.6	Case Studies	36
3.4	Results.....	37
3.4.1	Benchmark Li and Matthew [34].....	37
3.4.2	Benchmark Moeini and Afshar.....	39
3.4.3	Real Network: Chicó.....	40
3.4.4	Convergence Curves.....	41
3.5	Discussion.....	43
3.6	Conclusions	44
4.	Layout Selection for an Optimal Sewer Network Design Based on Land Topography, Streets Network Topology, and Inflows.....	47
	Preamble.....	47
4.1	Introduction	47
4.2	Background	49
4.3	Methodology.....	51
4.3.1	Selection of an Initial Layout.....	51
4.3.2	Iteration with Penalties in Excavation	54
4.3.3	Case Studies	57
4.4	Results.....	58
4.4.1	Benchmark Network Proposed by Li and Matthew	58
4.4.2	Benchmark Network Proposed by Moeini and Afshar.....	60
4.4.3	Benchmark Network Proposed by Duque et al.: Chicó.....	63
4.4.4	Computational Effort.....	64
4.5	Discussion.....	64
4.6	Conclusions	65
5.	Optimal Sewer Network Design for Cities in Hilly Regions	67
	Preamble.....	67
5.1	Introduction	67
5.2	General methodology for sewer networks design.....	69
5.3	Methodology adapted for hilly regions.....	70
5.3.1	Addition of drop manholes in the developed optimization scheme.....	70
5.3.2	Development of a drop manhole cost function	72
5.4	Case studies.....	73
5.5	Results and discussion	74

5.5.1	Results in the series of pipes.....	74
5.5.2	Results in Chicó sewer network	76
5.5.3	Comparison with previous works.....	80
5.5.4	Sensitivity analysis of the discretization parameter ΔZ in the excavation depth of the methodology with the extension of drop manholes	80
5.6	Conclusions	81
6.	Sewer network design methodology for low-cost, resilient, and reliable designs	85
	Preamble	85
6.1	Introduction	85
6.2	Methodology.....	87
6.2.1	Optimal sewer network design	87
6.2.2	Reliability index	90
6.2.3	Resilience index.....	90
6.2.4	Evaluation of resilience and reliability in sewer networks designs	91
6.3	Case studies.....	94
6.4	Results.....	96
6.5	Discussion.....	99
6.6	Conclusions	100
7.	Discussion.....	103
7.1	About the Optimal Design of Urban Drainage Systems	103
7.2	About the Cost of Urban Water Infrastructure	104
7.3	About the New Constraints.....	106
7.4	About the Proposed Methodology	107
7.4.1	Hydraulic Design.....	107
7.4.2	Layout Selection (Tree-shaped structure)	107
7.5	About the Advantages of the Directed Graph Structure.....	108
7.6	About the Results Obtained	111
7.6.1	General Results	111
7.6.2	Design Constraints	112
7.6.3	Sewer Systems in Hilly Regions	113
7.6.4	Sewer Systems in Flat Areas with Pumps.....	113
7.6.5	Reliability and Resilience of Urban Drainage Systems	114
8.	Conclusions and Recommendations	117
	Preamble	117
8.1	Conclusions	117
8.1.1	Conclusions on General Methodology	117

8.1.2	Conclusions on Hydraulic Design (HD)	118
8.1.3	Conclusions on Layout Selection (LS)	119
8.1.4	Conclusions on Sewer Network Hydraulics.....	120
8.1.5	Conclusions on Sewer Systems Resilience	121
8.1.6	General Conclusions.....	121
8.2	Recommendations on Future Works	122
8.2.1	Further Developments	122
8.2.2	General Recommendations.....	122
8.3	Publications Resulting from this Doctoral Thesis	123
8.3.1	Scientific Papers	123
8.3.2	Papers in International Congresses ad Conferences	124
8.3.3	Scientific Papers Under Reviewing.....	124
9.	Future works	127
	Preamble	127
9.1	Lines of Work	127
9.2	Papers in Development.....	128
9.2.1	Optimal Design of Series of Pipes in Sewer Systems Including Pumping Stations for Flat Terrains	128
9.2.2	Analysis of the effect of pipe roughness in optimal sewer networks with drop manholes in steep terrains.....	129
9.2.3	Optimal Sewer Network Design with Pumping Stations.....	129
9.3	Divulgation plans.....	130
9.4	Collaboration with the Government of Colombia.....	131
	Appendix 1	133
	Appendix 2	143

1. Introduction

Preamble

This first chapter of the doctoral thesis is dedicated to make an introduction related to the need to solve the problem of the lack of urban drainage, both wastewater and stormwater that exist today globally. The approach followed in the thesis is to develop a methodology that allows the optimal design of sewer networks, through a mathematical approach, which increases the economic and financial viability of these urban infrastructure projects. The introduction is divided into two parts. The first part describes the motivation for the research, establishing the characteristics of traditional design methods that have resulted in costly systems that are difficult to operate and maintain, causing a large percentage of the world's population to lack access to this basic sanitation service, with the associated public health and quality of life problems. This raises the research question.

The second part of the chapter is devoted to displaying statistics on the coverage of sewer services, both wastewater and stormwater, at the global, Organization for Economic Cooperation and Development (OECD), Latin American, and, finally, Colombia levels. The goal is to draw attention to the lack of adequate urban drainage systems coverage. These statistics show that we are still a long way from meeting the United Nations' Sustainable Development Goal (SDG) No. 6 of "Ensure access to water and sanitation for all." The issue is most acute in developing countries, particularly in the poorest communities. There is a severe lack of modern sewer systems in Sub-Saharan Africa, Latin America, and Southeast Asia, particularly in rural areas and small and intermediate cities.

1.1 Motivation: Need for Optimal Sewer Systems

Even though conventional design and construction methodologies for urban drainage networks are widely known and used around the world, it has not yet been possible to achieve universal coverage of basic sanitation services, which are essential for a good quality of life. The lack of this service is especially serious in poor areas of developing countries, where it has been impossible to meet or progress toward meeting United Nations Sustainable Development Goals. The cost of this conventionally designed infrastructure is economically and financially unfeasible for many communities, which is one of the many causes that have led to this situation.

The conventional design of sewerage systems, both stormwater and wastewater, has advanced very little in recent years and is based on empirical knowledge both for the choice of the optimal layout and for the hydraulic design of the integrated system. Usually, the layout selection is made by the designer based on his experience or the experience that other engineers have written about in sanitary engineering texts. Usually purely geometrical and topographical methods are used without taking into account other factors such as flow distribution and the possible variation in the number and location

of the delivery points of the water. Similarly, the hydraulic design, although based on modern equations, leaves it up to the designer to choose the slope of each of the sections. This results in a correct design from the point of view of hydraulics that respects all the restrictions, again empirical, that are imposed to ensure an adequate behavior of the system, but which is very costly.

Additionally, extreme topographical features influence the design of sewer systems in some cities. Because of the flat topography, the sewer system must be supplemented with pumping stations, which are costly to build, operate, and maintain. Energy consumption costs, which are frequently higher than construction costs, may make the system unviable once more. Naturally, this is subject to cost optimization processes from the design stage. A very hilly topography, such as that found in mountain cities, requires sewer systems to be accompanied by numerous drop manholes and other types of energy dissipation structures, the cost of which can be several times that of the pipes and manholes. Furthermore, in combined sewer systems, the need for structures such as combined sewer overflows and delivery structures to in-town receiving bodies significantly raises construction and operating costs.

Also, in some areas of the world, particularly those located in the tropics, the intensity and frequency of rainfall events are increasing due to climate change. This means that stormwater systems will have to move larger flows, requiring more capacity in the systems. This leads to greater pipe diameters and a significant increase in construction costs.

All the preceding highlights the importance of incorporating the concept of optimization in order to achieve the lowest possible cost into the design process of sewer systems. Sewer costs can thus be reduced to less than half of their original value, making them economically viable for these communities. This is done while adhering to all the hydraulic, construction, and commercial standards and constraints that have ensured the proper operation of sewer systems around the world.

Surprisingly, this had already occurred in the case of the other urban hydraulic networks, the drinking water distribution networks, since the mid-1990s. Since then, various heuristics have been used to solve the problem of optimizing the design of these networks in order to achieve the lowest cost while respecting hydraulic and water quality constraints. The optimized design of these networks is now considered a solved problem. There are heuristic-based methodologies that lead not only to the lowest-cost networks, but also to those that are more resilient and better manage water quality. This has not been the case with urban sewer networks.

All of the above formed the main motivation for this doctoral thesis. Then, the question to answer was: Is it possible to develop a methodology that allows the optimized design of a minimum cost sewer network, including the layout selection and the hydraulic design respecting all the hydraulic, constructive, and commercial constraints?

1.2 Current Needs

This section describes the current unmet needs for wastewater and stormwater systems in urban areas around the world. The statistics presented show that basic sanitation service coverage varies greatly between developed and developing countries. In some cases, the lack of coverage is severe,

particularly in rural and small-town areas. The statistics for stormwater drainage show an even greater backlog.

Current needs are divided into two categories: a lack of basic sanitation services, such as sewer networks, wastewater treatment plants, on-site sanitation systems, and non-conventional systems, and a lack of stormwater drainage services. Each of these is further subdivided into global statistics, OECD statistics, Latin American statistics, and Colombian statistics.

1.2.1 Wastewater

Regarding the coverage of the wastewater system, the gathered information will be divided into four groups based on the geographical scope: global, within the OECD, at the Latin American level, and at the national level.

1.2.1.1 Global Statistics

Within the framework of the Sixth Sustainable Development Goal (SDG 6), which refers on ensuring the availability and sustainable management of water and sanitation for all, the United Nations has been monitoring the global coverage of wastewater systems using different statistics. The most recent studies on the subject are from 2020. However, these studies exhibit significant gaps because they are managed and carried out mainly by each state, and numerous states do not prioritize the collection of that data. For this reason, the statistics presented below are the product of the data available only.

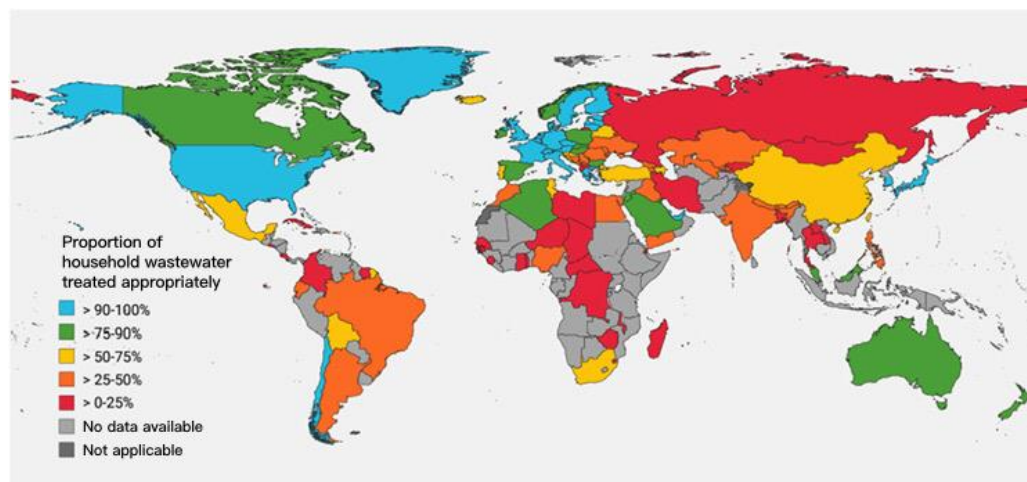

Figure 1.1. Percentage of household wastewater adequately treated in 2020. Taken and adapted from [1]

About the current state of sanitation services, by 2020, 54% of the global population used a sanitation service safely. Of this, 34% used private sanitation facilities connected to the sewage systems that treated the water, while 20% used toilets or latrines that ensured the secure on-site disposal of excreta. Moreover, 78% of the world's population used at least one basic sanitation service [1].

Additionally, Figure 1.1 shows that in the majority of countries for which data was available, less than half of the wastewater generated by households received proper treatment. This is complemented by the fact that more than 1.7 billion people do not have access to basic sanitation

services, and in 2020, 45% of domestic wastewater was discharged without applying safe treatment [1]. Although these statistics are not direct indicators of sewerage status, the absence of adequate sanitation services and wastewater treatment facilities can be attributed in part to the lack of a safe and adequate sewerage system.

1.2.1.2 OECD

Emphasizing in the OECD, sewerage coverage is considered a key indicator in the development of a country's social well-being. For this reason, by 2019 the average sewerage coverage among OECD member nations stood at 84% [1]. However, there are important differences between OECD member countries. This is variation can be seen in Figure 1.2, where there are countries that reach a coverage rate above 99%, such as Denmark, Hungary, Sweden and Finland, in contrast to others like Ireland, and Mexico, where rate is below 80%.

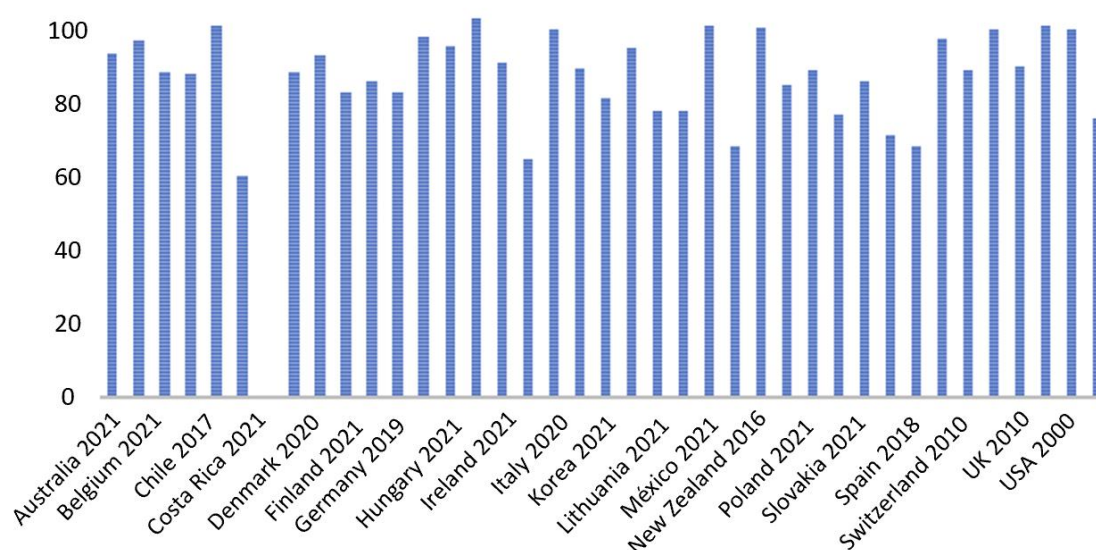

Figure 1.2. Total public sewerage (% of the resident population connected to a wastewater collection system). Retrieved and adapted from [2]

These statistics are a key indicator of the development and social well-being of a country, so the large differences indicate inequality between the member countries of the Organization. Based on this, the OECD has recommended its member countries to adopt policies and measures to improve sewerage and basic sanitation coverage.

1.2.1.3 Latin America

Regarding sewerage coverage in Latin America, according to UNESCO the coverage rate in 2015 was 65% [4]. Additionally, even though basic sanitation coverage has increased in recent decades at a regional level, there still exist countries where coverage remains considerably inadequate. For example, a study carried out by the Economic Commission for Latin America and the Caribbean (ECLAC) in 2021 indicated that in some countries, such as Haiti and Nicaragua, coverage is less than 10%, while in others, such as Argentina, Chile and Uruguay, the rate exceeds 80% [3]. The countries with coverage below 85% can be seen in Figure 1.1 in the green bars.

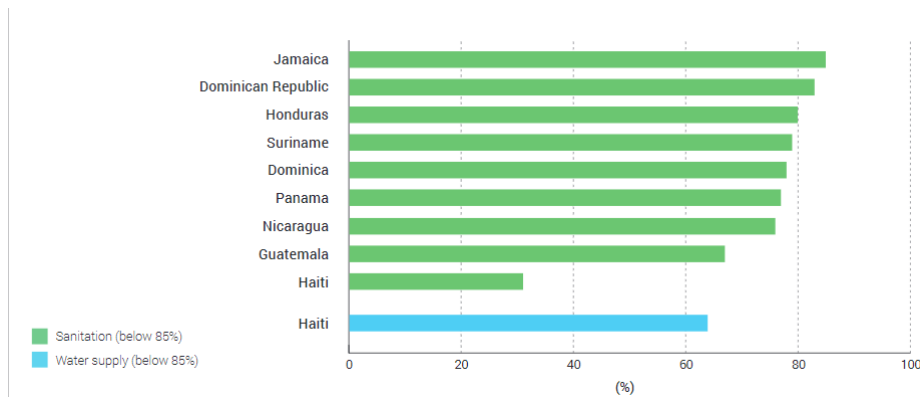
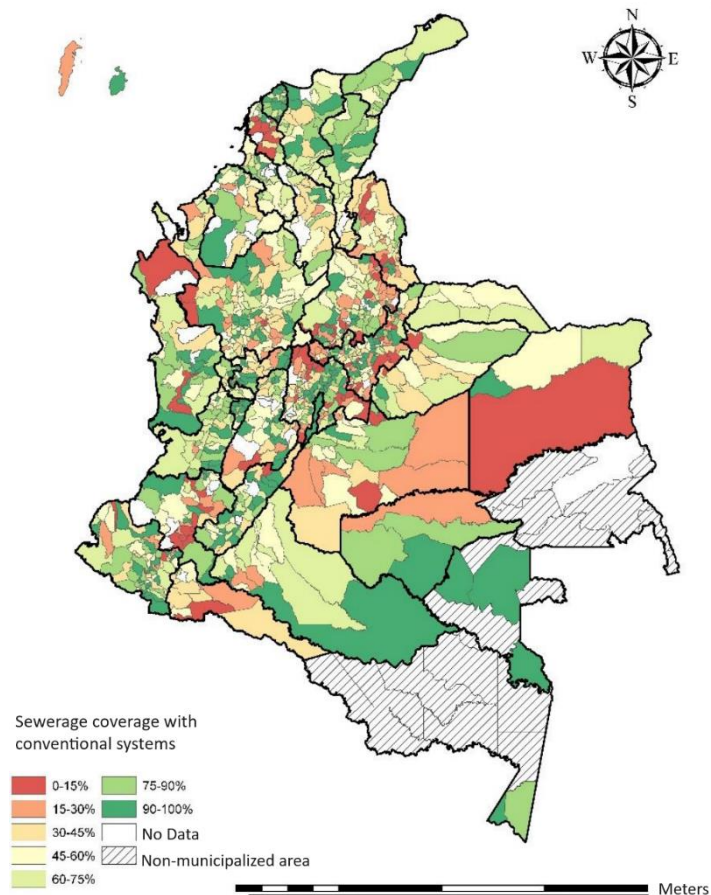

Figure 1.2. Countries in Latin America and the Caribbean with low levels of access to at least basic water and sanitation services. Retrieved from [4]

In the region, nearly 89 million people lack a basic sanitation service, and 495 million lack safely managed services [5]. Additionally, it is observed that there are large differences within the same countries, where coverage is significantly lower in rural areas than in urban areas (22% on average). These differences are exacerbated by the technical solutions implemented in rural areas, such as wells, septic tanks, and latrines [5]. However, these solutions do not ensure a level of quality or functionality comparable to that found in urban settings [4]. The process of decentralization in many countries has caused sewerage systems to be highly fragmented, resulting in a numerous service provider that often struggle to function optimally due to insufficient resources and incentives to deal effectively with the complexity of the processes involved in providing services.

1.2.1.4 Colombia

Finally, regarding Colombia, it stands as one of the countries where significant internal differences can be observed in terms of coverage. According to Law 142 of 1994, the responsibility to ensure effective provision of public services, including sewerage, to all residents within a jurisdiction through public service companies lies with municipalities and districts. As mentioned in the section of Latin America, this creates problems due to the lack of system integration and the segmentation of service areas. According to National Administrative Department of Statistics (DANE), by 2019, 76.6% of households nationwide had sewerage service [6]. In addition, by 2020, 16% of Colombia's municipalities (181) had coverage equal to or less than 15%, while 20% of the municipalities (223) had coverage between 15% and 30%; and only 7% of the municipalities (81) had sewerage coverage greater than 90% [7]. Sewerage coverage nationwide is portrayed in the following map.



3 Figure 1.4. Sewerage coverage with conventional systems. Retrieved from [7]

At the regional level, large differences in the range of coverage can also be observed. For example, Figure 1.4 portrays the difference between urban and rural coverage in a significant way. Where urban areas have more coverage of sewerage systems (632 municipalities in coverage ranges between 90% and 100%) than rural areas (only 35 municipalities in coverage ranges between 90% and 100%). On the other hand, the rural zone of 764 municipalities presents sewerage coverage less than or equal to 15%, this indicates where the efforts of the national government should be directed to guarantee basic sanitation in the country.

1.2.2 Stormwater

The information reported of the stormwater coverage at the national and international levels is limited because it is usually related to the wastewater system. This is due to the fact that both systems are usually managed jointly as combined systems.

The information presented below is taken from the report "Planning for the preparation of the sectoral strategic plan for urban rainwater drainage in Colombia BID-INE/WSA," which addresses the coverage of stormwater drainage in the country's major cities in detail. Information about Barranquilla, Bogotá, Cartagena, and Medellín will be presented.

To begin, it is well known that Barranquilla has a separate sewer system, which is primarily used to transport wastewater. Typically, water is transported underground and flows into major bodies of water surrounding the city, such as the Magdalena River, the León and Grande streams, which lead to

the Mallorquín Marsh. Because the city currently lacks urban drainage, heavy rain events result in large streams and flooding.

In terms of the capital city, Bogotá has the highest coverage in the country in terms of urban drainage systems that are linked to wastewater treatment plants and potable water treatment plants. According to the reports, Bogotá's sewer system has both combined and separate areas. The downtown sector has a combined system, while the low areas to the west have a separate system. Figure 1.5 depicts the coverage of Bogotá's stormwater, wastewater, and combined sewer systems [8].

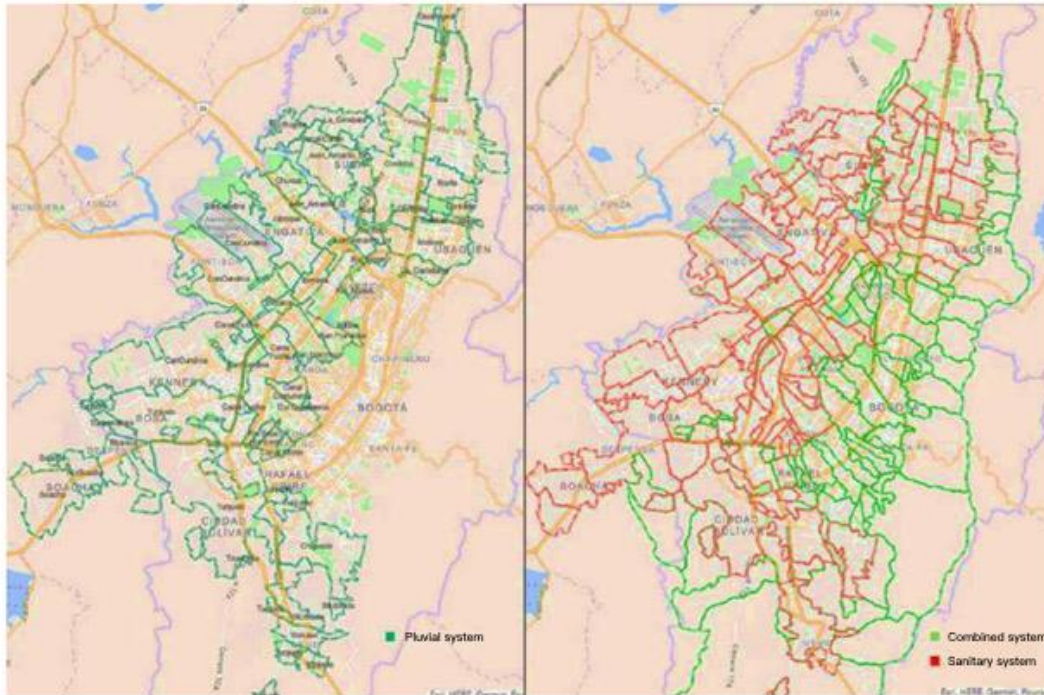

Figure 1.5. Coverage map of storm, sanitary and combined sewer systems. Taken and adapted from: Planning or the preparation of the sectoral strategic plan for urban stormwater drainage in Colombia BID-INE/WSA. Retrieved from [8]

The map on the left side of the image depicts the stormwater system network, while the map on the right side of the image depicts the combined sewer system network (green lines) and the wastewater system network (red lines). The system has 10,170.02 km of sewer networks, of which 1,862.38 km correspond to the combined system, 4,970.90 km to the wastewater system, and 3,336.74 km to the stormwater system, covering approximately 1.7 million users [8].

Regarding Cartagena, there is no updated information of stormwater systems coverage. In fact, no changes to the stormwater system have been documented since 2008. Cartagena has a network of streams and channels that cover a total area of 2215.60 hectares [8]. Cartagena has grown in recent years, indicating that the stormwater system does not provide extensive coverage.

The city of Medellín has 4,245.14 km of aqueduct lines that are divided into wastewater, stormwater, and combined systems [9]. It is known to have a combined system coverage of 35.55%, a stormwater coverage of 26.83%, and a wastewater system coverage of 37.62% [8]. Medellín, along with Bogotá, is regarded as one of the cities with the greatest coverage of stormwater drainage.

Now that the generalities of each city have been resumed, a table is presented showing the coverage percentages of conventional sewerage systems:

Table 1.1. Table showing the percentage of coverage of conventional sewerage systems in different cities of Colombia. Retrieved from [8]

	Global	Urban	Rural
Barranquilla	97.04%	97.09%	77.01%
Bogotá	98.98%	99.24%	0.74%
Cartagena	44.48%	47.90%	9.53%
Medellín	95.45%	97.60%	40.79%

Table 1.1 confirms that the highest coverage in drainage systems is held by the capital city, despite its relatively low coverage in the surrounding rural areas. On the other hand, the cities of Medellín and Barranquilla also have a significant percentage of coverage of drainage networks. Finally, it is important to note that Cartagena has the lowest overall coverage, which was expected due to its low investment in efforts to improve its rainwater drainage systems in recent years.

Table 1.2. The table show the percentage of coverage of sewerage systems, including alternative solutions. Retrieved from [8]

Global	Urban	Rural
46.12%	48.48%	28.04%

Table 1.2 refers to the coverage of sewerage systems, including alternative solutions, exclusively for the case of Bogotá, as it is the only city that has a significant percentage regarding alternative solutions.

As previously mentioned, the information reported for rainwater drainage coverage is usually quite limited. However, for the year 2020, the National Planning Department of Colombia estimated that more than 43% of the Colombian population does not have an adequate rainwater drainage system [10].

2. Sewer Networks Design (SND)

Preamble

The purpose of this chapter is to present the optimal urban drainage network design problem. First, a brief description of the problem from the technical point of view is given, starting from the description of the purpose of an urban drainage network and describing its component parts. It is established that any sewer network must have a tree structure, which implies that a water particle entering the system can only follow one and only one path from its entry point to the network outfall or exit point. Subsequently, a formal definition of the problem of making a minimum cost design of this type of network is made. It is established that the problem has two main mutually interdependent components: the layout or tree selection and the hydraulic design. The input data and information required for the minimum cost design are described in detail, as well as the general procedure and methodology developed.

Once the problem statement is understood, the solution space can be established. Given the large number of variables involved in the minimum cost design process, it is important to understand the size of this space. Thus, in the third part of this chapter we will establish how to calculate it for two different cases. On the one hand, for a series of sewer pipes, consisting of \mathcal{M} manholes (nodes), and exactly $\mathcal{M} - 1$ pipes (arcs). Each manhole has one inlet and one outlet pipe, except for the last one (network outfall) which has only one inlet pipe. And, on the other hand, for a tree-shaped network which would have $(\mathcal{M} - 1)^{\mathcal{M}-2}$ different alternatives of trees. In order to size the solution space, a comparison of its size is made for different number of nodes while analyzing the growth rate as a function of that number.

Since the process of optimizing a design aims to provide the design with the minimum cost within a set of hydraulic, constructive, and commercial constraints, it is important to establish the cost equations of each component parts of the sewer network in order to establish the objective function. The third part of the chapter introduces the cost equations of some of the main components of an urban drainage network. The general equations describing the costs of pipes, manholes, drop manholes, and in-line pumps and pumping stations are given. The equations show the independent variables of which these costs are function.

Finally, the design must comply with a series of constraints that allow correct behavior from the hydraulic point of view, lead to feasible construction processes, and make use of the materials and diameters of sewer pipes existing in the local market. These constraints depend on the technical standards and regulations of each city, but they are generally very similar since they are based on the experience gained from successful projects already built worldwide. The constraints used for the designs that are part of this doctoral thesis are shown at the end of this chapter.

2.1 SND Description

As is well known, the purpose of a sewer network is to drain rainwater or wastewater produced in an urban center or part of it. In the case of rainwater, the drainage system is designed to handle the flows produced by a design storm. This storm is characterized by a return period, duration, and intensity selected by the designer, allowing the calculation of a rainfall hyetograph that falls in the urban. Using this hyetograph, the inflows to the pipes can be calculated. On the other hand, for the design of a wastewater system, the design is carried out by calculating a future wastewater flow rate projected to a return period of 20 or 30 years. Wastewater should include all its components: residential, industrial, commercial, and, in some cases, special wastewater. The design must consider the standards, regulations, and municipal laws, which typically establish that in every street of the city there must be a wastewater sewer pipe and a stormwater sewer pipe, except in the case of combined systems where only one pipe exists. In addition, these regulations establish technical and constructive constraints to ensure the correct operation of the system. One of these constraints' states that the flow within the pipes must always be at free surface conditions, making it a problem of open channel hydraulics.

Therefore, the general layout of a sewer network consists of a pipe in every street and road of the city joined at the corners by a manhole and forming a tree-like geometric configuration. The inflows enter the network at multiple points, but for design purposes they are concentrated in the manholes at each corner. The layout has a single outfall, so that a drop of water entering the system can travel only by one route. The outfall can be a receiving body, a wastewater treatment plant, or a major sewer already operating in that urban area. Manholes usually have other functions, the most common being inspection and maintenance (cleaning) of the system. However, manholes can also have different uses, such as drops in very steep terrains or facilitating in-line pumping in flat terrains. All network components including pipes, manholes, drops, pumping stations, and other possible components are the subject of the system design.

The aim of the design is to determine the tree-like layout, the diameter, and the filling ratio of each pipe, the invert elevations of each manhole (which coincide with the invert elevations of the incoming and outgoing pipe(s) of the manhole), the location of drop manholes and/or pumping stations, and other structures, within a scheme with hydraulic and constructive constraints, trying to achieve a low construction, maintenance and operation cost. The process of obtaining the tree-like layout is known as Layout Selection (LS) and the calculation of the network components is known as Hydraulic Design (HD).

2.2 Problem Definition

The predominant approach to solve the sewer design problem considers the LS and the HD as independent (and subsequent) problems. This separation allows for tractability of the problem i.e., the designer can see the evolution of the layout and the minimum-cost design obtained for each one of them in the second part of the problem. Even though the shortest path algorithm always gives the

minimum cost for a given layout, the evolution of the layout selection part does not always get the one that would produce the global minimum-cost.

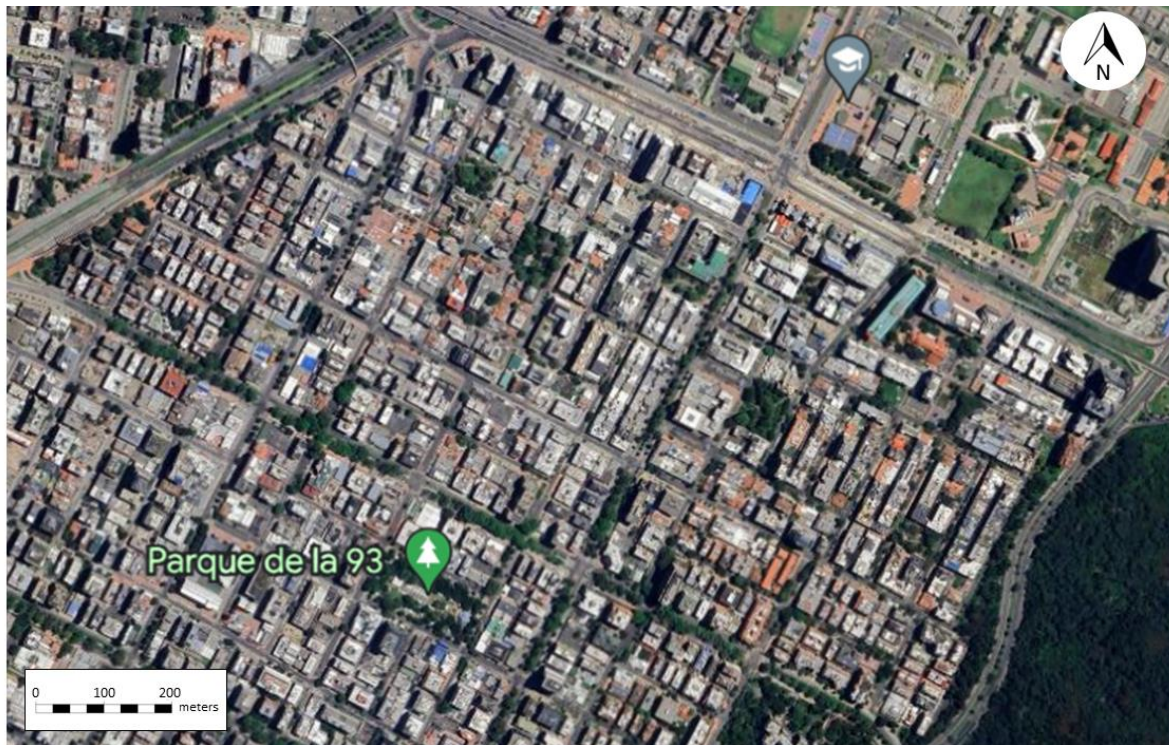

Figure 2.1. Satellite image of barrio Chicó in Bogotá.

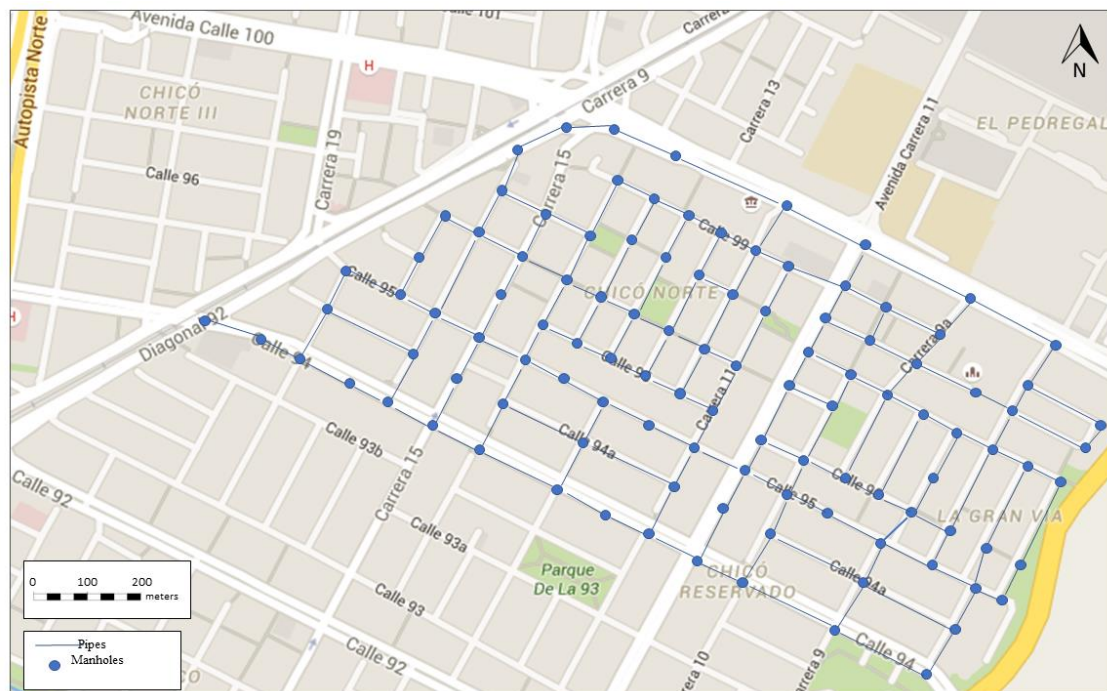

Figure 2.2. Topology of the sewerage network in Chicó neighborhood.

In the LS process, the aim is to identify the optimal layout to solve the sewer design problem. To do so, certain input parameters must be taken into consideration. Primarily, the urban topology, defined by the streets, is crucial to determine the location of the manholes and the length of the pipes connecting them (See Figure and Figure , shown in previous page). The manholes data are represented by coordinates (x, y) . The topography (see Figure) of the terrain is also incorporated, presented in (z) coordinates, where "z" denotes the altitude of the terrain. This information is crucial to know the elevation of each manhole. To continue, it is essential to obtain the inflows of each manhole, which can be derived from both rainfall and wastewater. Also, information of the location of the outfall of the sewer system is available. Finally, this process results in the tree structure and additional information, such as the type of pipe (inner-branch pipes or outer-branch pipes), as well as the direction and magnitude of the flow rate in each pipe.

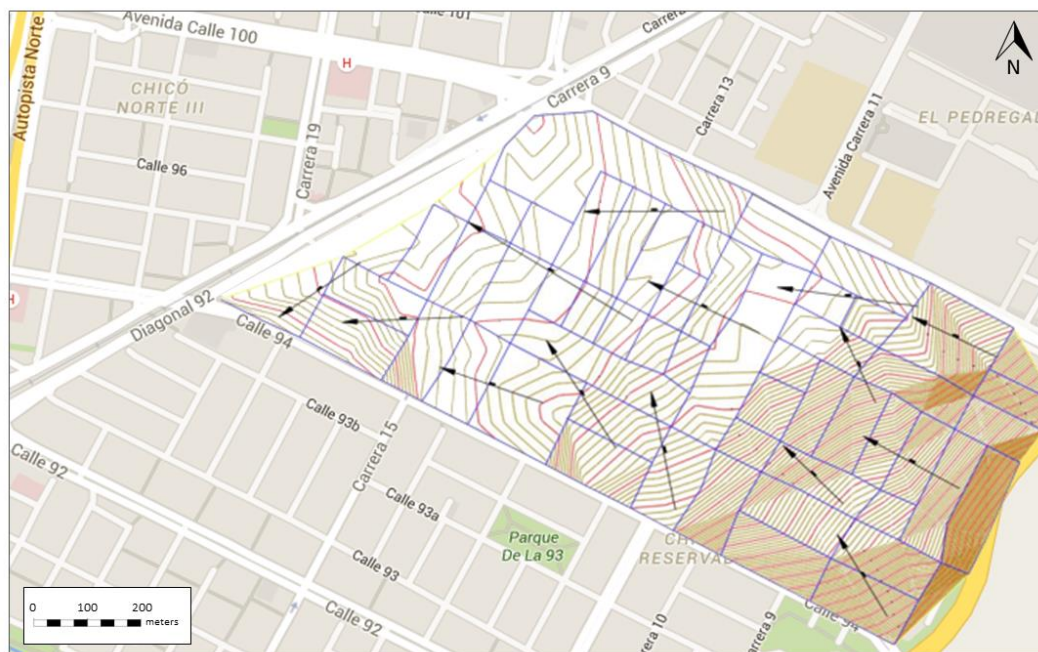

Figure 2.3. Topography of Chicó neighborhood.

The second stage of the procedure deals with the HD of the sewer network. In this phase, several factors are considered to achieve an optimal design, taking into account that the tree structure from the previous step is already selected. These include the length of the pipes, the different diameter options available, the roughness of the materials used, and the cost equations related to pipes, excavation, manholes, drop manholes and pumps. In addition, the essential constraints for the sewer problem must be considered and complied with. These constraints include the minimum allowable diameter, the minimum velocity, the minimum shear, the maximum velocity, as well as the minimum and maximum installation depth. Also, attention must be paid to the maximum filling ratio to ensure proper operation of the system.

The HD will primarily provide the corresponding diameters for each pipe. In addition, this process will generate relevant information such as pipe slopes, inlet and outlet depths for each pipe, drop heights for each drop manhole and pumping heights. One characteristic of the optimal sewer network design is that the possible diameters for each of the pipes are a discrete variable; each diameter can only be one from the set of commercial diameters in which the pipes are manufactured. Therefore,

the optimal sewer network design problem is a discrete variable problem. Figure 2.4, shown below, represents the general process followed throughout this investigation. The left side represents the layout selection process, while the right side shows the hydraulic design process.

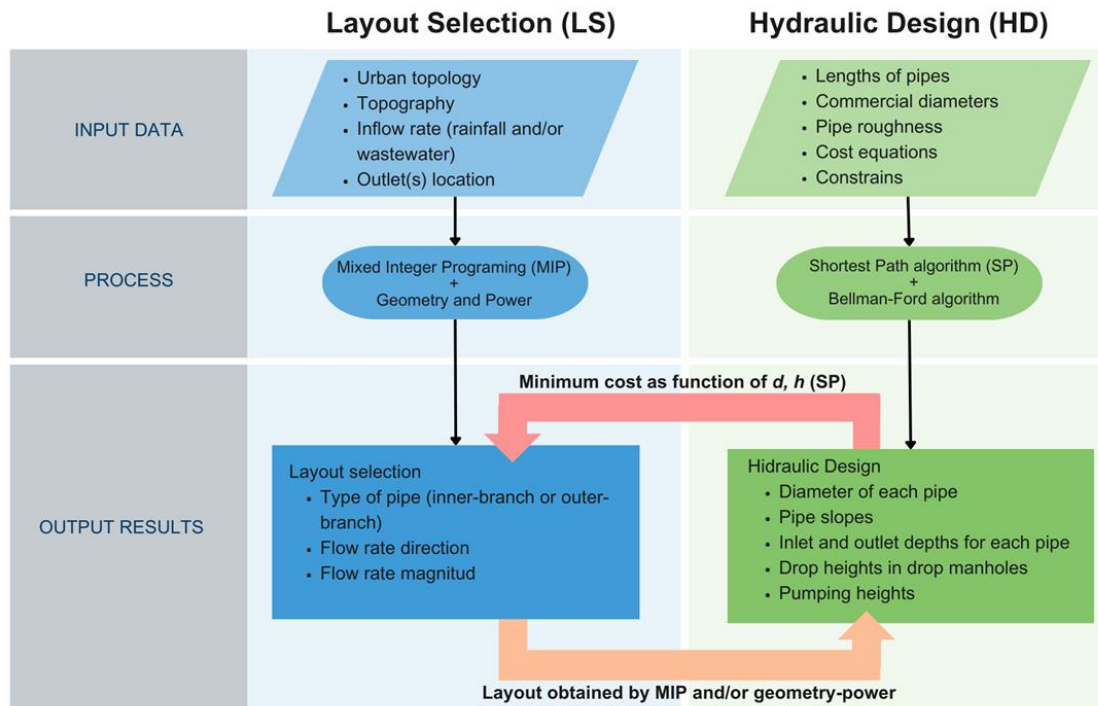

Figure 2.4. Flowchart methodology for sewer optimization.

The combination of all these elements is essential to achieve an efficient and adequate hydraulic design that meets the operational requirements and ensures the functioning of the sewer system in question, in addition to ensuring the minimum cost design.

The result of the optimal design of a sewer network includes the final tree. For each pipe, it includes the flow direction, flow rate, diameter, starting invert elevation, ending invert elevation, filling ratio and slope. For each manhole, it provides the invert elevation; for each drop manhole the drop height; and for each pumping station the pumping height, pumping flow rate, and required power are determined. All this is achieved while complying with the hydraulic and commercial construction constraints typical of an urban sewer system. In addition, a cost equation is used, and it takes into account the length and diameter of all the pipes, the volume of excavation required in each trench, the drop height in each drop manhole, and the pumping head of each pumping station. Figure 2.5 shows the result of an optimized sewer network design process.

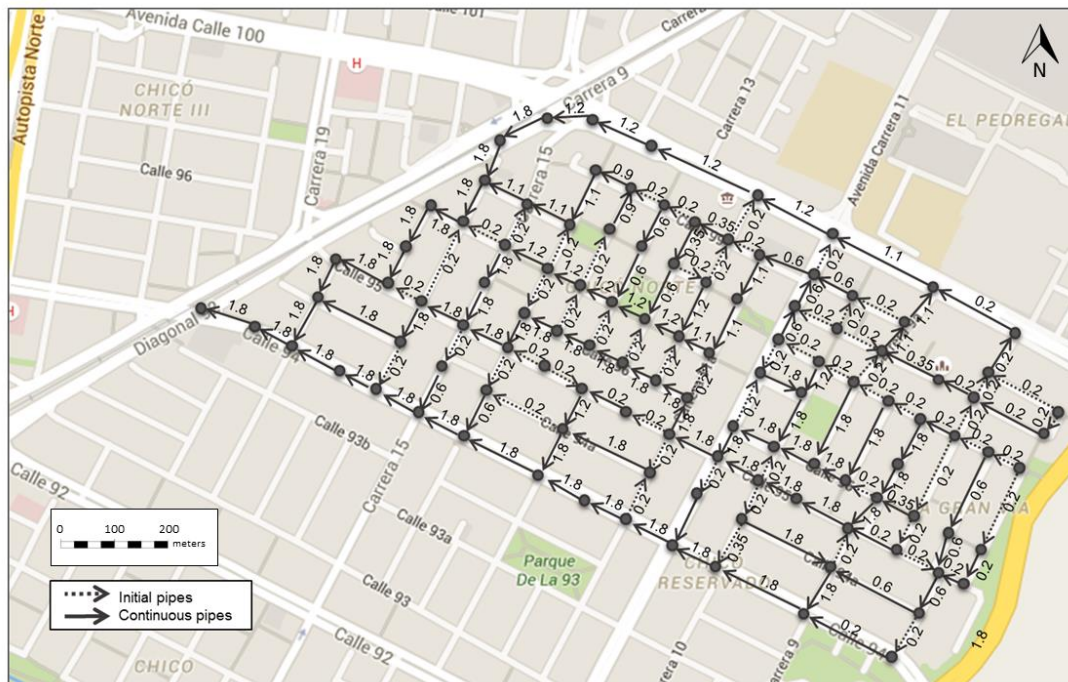

Figure 2.5. Tree structure for Chicó neighborhood.

2.3 Problem Size

To calculate the size of the problem, which is the solution space, the known data are the number of manholes and pipes, the available pipe diameters, the possible slopes, and the outfall location. The set of possible slopes is determined by given minimum and maximum excavation depths, and an excavation precision. Due to constructive limitations on site, the possible excavation depths are assumed to be a discrete set ranging from the minimum to maximum depths; with constant, predetermined, steps between set elements. Moreover, every manhole could either have a pump to make up for energy losses and changes in elevation common on flat terrains, or have a drop, common in steep terrains.

The size problem can be calculated using a connected, directed graph for which the nodes are labeled. In this graph, the nodes represent the manholes, the edges represent the pipes, and their directions correspond to the direction of water flow. Furthermore, this graph is a rooted tree: This means that one and only one of the nodes has no exiting edges (the outfall) and the rest have a single exiting edge. A particular case of interest is a series of sewer pipes. In this case, every manhole is also restricted to a single entering pipe. For series is important to mention that there will be no freedom in direction, meaning that the flow direction is predetermined by the position of the manholes and does not affect the size of the problem.

The large number of variables involved in the design process of a sewer network, as well as the extensive set of values that each of them can assume, imply that the solution space of the optimization process (minimum cost design) is extraordinarily large. For this reason, it is necessary to use heuristics that allow the efficient exploration of this space or approximations based on empirical experience to reduce this space. In the following paragraphs, this solution space is detailed through some examples assuming that the set of manholes is \mathcal{M} , the set of edges is \mathcal{E} , the set of available diameters is D , and the set of the discrete slope steps is S .

2.3.1 Series of Pipes

Given these conditions, if there are \mathcal{M} manholes (nodes), then there must be exactly $\mathcal{M} - 1$ pipes (edges) because every node but one has an exiting edge. This will later be shown to hold for arbitrary trees as well. In a series, the manholes are in order: water can only flow from one manhole into the next one until it reaches the outfall. Hence, the first manhole is chosen from \mathcal{M} manholes, the second from $\mathcal{M} - 1$; and so on, until the outfall is the only remaining manhole. Therefore, if the order of the manholes is not given, the number of possible series from an \mathcal{M} -sized system is:

$$\mathcal{M} \times (\mathcal{M} - 1) \times (\mathcal{M} - 2) \times \dots \times 2 \times 1 = \mathcal{M} ! \quad (2.1)$$

Note that if the order of the manholes is given only one layout is possible for the series, therefore, in this case the number of possible series is equal to 1.

The inclusion of diameters, slopes, and pumps reduces to a combinatorial problem. \mathcal{E} is the number of pipes or edges of the graph (already known to be $\mathcal{M} - 1$). First, suppose that for one of the pipes there are D possible diameters. Then, there are D possible ways to build that graph; the layout is preserved but that pipe has D possibilities. If that is now the case for every pipe, the number of possible ways to build the graph increases to $D^{\mathcal{E}}$. The same applies for the slopes, so that the number of graphs varying the slopes is $S^{\mathcal{E}}$. The case of the pumps is Boolean problem, since at every manhole the presence of a pump is either true or false. Again, if this were the case for a single manhole then there would be twice as many possible series. Since this is possible at any manhole, the number of possibilities is $2^{\mathcal{M}}$. The same could be applied to drop manholes.

Now, counting the total possible series is a matter of combining all the results. It is in fact the product of the values obtained. Therefore, the number of possible series consisting of \mathcal{M} manholes, each one of them with or without a pump, with D different diameters and S different slopes for every pipe is:

$$2^{\mathcal{M}} \cdot (D \cdot S)^{\mathcal{M}-1} \cdot \mathcal{M} ! \quad (2.2)$$

Recall that if the order of the manholes is given, the number of possible layouts is equal to 1, so the solution space of a series with ordered manholes is:

$$2^{\mathcal{M}} \cdot (D \cdot S)^{\mathcal{M}-1} \quad (2.3)$$

Now, it is important to mention that the solution space explained before does not include the constraints that must be met in sewer systems. These constraints are that the slope must always be positive so that the flow can flow by gravity, and that the downstream diameter must always be greater than or equal to the upstream one to avoid blockages in the pipes. By considering these constraints the solution space is reduced.

2.3.2 Sewer networks

The difference between series of pipes and sewer networks is that the latter have a tree shaped layout. The structure of the previously mentioned graph changes to model the tree-shaped layout; in each manhole, there is an additional node for every pipe exiting it, i.e., if three pipes exit from a manhole, this manhole will be represented by three nodes. Additionally, the outfall is also modeled as a node. As for the edges, these represent the pipes, as in the series. Taking the preceding into account, $\mathcal{E} = \mathcal{M} - 1$ is fulfilled in the case of networks due to connectivity and the fact that every node except one has an exiting edge. Since the nodes are labeled, Cayley's Formula (1889) dictates that the number of possible trees is $\mathcal{M}^{\mathcal{M}-2}$. For a rooted tree, note that this is the same as finding the number of possible trees for $\mathcal{M} - 1$ nodes, and connecting a root to any of the nodes; yielding a total of $(\mathcal{M} - 1)^{\mathcal{M}-2}$ possibilities. The inclusion of diameters, slopes and pumps is exactly the same as for series, so the solution of the problem is complete. This ultimately yields that the problem size in a sewer network is:

$$2^{\mathcal{M}} \cdot (D \cdot S)^{\mathcal{M}-1} \cdot (\mathcal{M} - 1)^{\mathcal{M}-2} \quad (2.4)$$

2.3.3 Comparison and Growth

The problem is much larger over networks than series with more than 7 manholes, this can be shown by the following inequalities. Since the pump, diameter and slope factors are the same in both cases, the only interesting part is whether $(\mathcal{M} - 1)^{\mathcal{M}-2} > \mathcal{M}!$ with more than 7 manholes. If the latter holds, $\mathcal{M} - 1 > 3!$ and so in the case of networks:

$$(\mathcal{M} - 1)^{\mathcal{M}-2} = (\mathcal{M} - 1)^2 \cdot (\mathcal{M} - 1)^{\mathcal{M}-4} \quad (2.5)$$

On the other hand, in the case of series:

$$\mathcal{M}! = \mathcal{M} \cdot (\mathcal{M} - 1) \cdot \dots \cdot 3! < \mathcal{M} \cdot (\mathcal{M} - 1)^{\mathcal{M}-4} \cdot 3! \quad (2.6)$$

Comparing both cases:

$$(\mathcal{M} - 1)^2 \cdot (\mathcal{M} - 1)^{\mathcal{M}-4} > \mathcal{M} \cdot (\mathcal{M} - 1)^{\mathcal{M}-4} \cdot 3! \quad (2.7)$$

$$(\mathcal{M} - 1)^2 > 6\mathcal{M}$$

This final inequality holds for any integer greater than 7, and so a network with 7 or more manholes has a larger solution space than a series with the same number of manholes.

In both cases, there is polynomial growth with respect to both diameters and slopes (though the degree is the number of manholes, which can be extremely large). With respect to pumps, the growth is exponential dependent on the number of manholes. The series also has factorial growth with respect to manholes, whereas the tree has double exponential growth with respect to manholes. As reference value, note that a network of 15 manholes has more than a trillion possible trees, excluding the varying diameters and slopes.

The following figure illustrate the solution space for both series and network varying the number of manholes. In both cases, the number of diameters and slopes were set at ten.

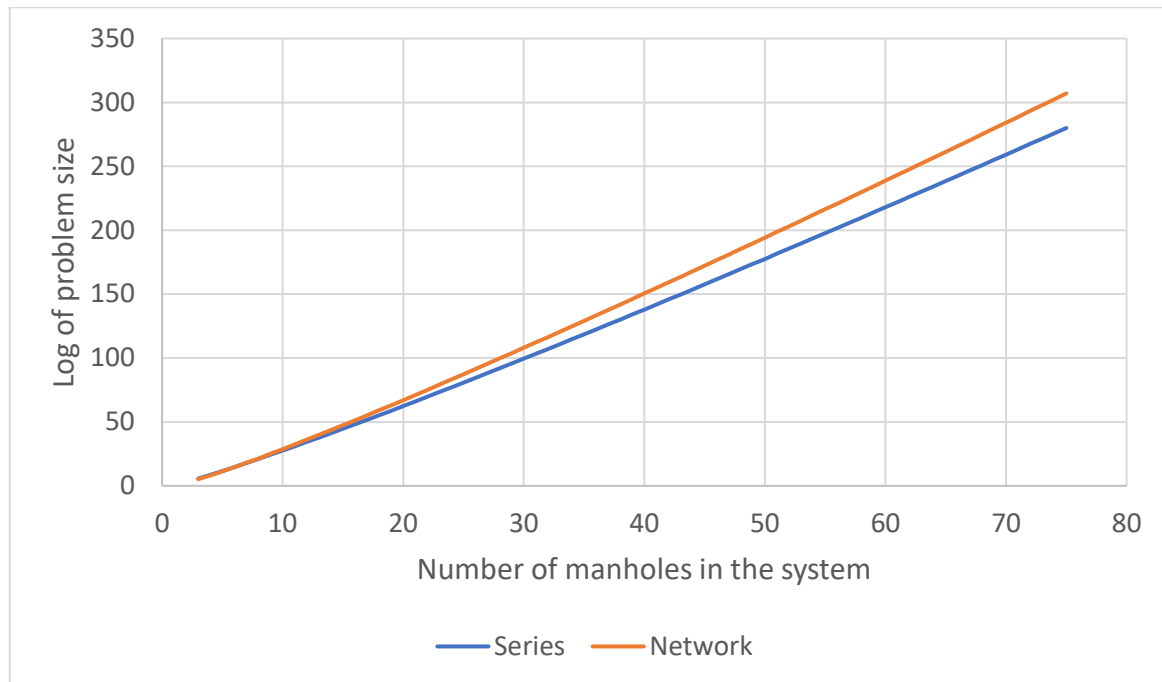

Figure 2.6 Solution space graph varying number of manholes.

2.4 Cost Equations

The process of optimal design of a sewer network is based on knowing the equations that define the costs of each of the main component parts of the sewer system: the pipes, the manholes, the drop manholes and the in-line pumping stations. The equations should make it possible to calculate the relative cost of each part compared to the others. In some cases, the costs of one component increase or with respect to another, which increases the complexity of the optimization process. An example of this is how the diameter of a pipe varies as a function of its slope; at a higher slope, the diameter tends to decrease for the same design flow, thus lowering its costs, but the costs of excavation and possible pumping would increase.

The costs, and therefore the equations, vary from country to country depending on factors such as energy cost, labor cost, transport cost, etc. However, usually the form of the equations is consistent between different countries, which is why general equations can be formulated for the optimization process described in section 2.2, simply by adapting the coefficients and exponents to local conditions. The same could be done with any other component or structure that forms part of the sewer network under design. The general form of the equations for the principal components is shown below, accompanied by some of the equations for particular cases reported in the international technical literature.

i- Cost of Pipes

The cost of a pipe depends primarily on three variables, its length, its excavation volume, and its diameter. The coefficients and exponents of the equation can vary according to the pipe material. Therefore, the general form of the cost equation for a pipe is:

$$C = c_1 * L * d^n + c_2 * L * b * \frac{h_{in} + h_{out}}{2} \quad (2.8)$$

Where:

- C : is the cost of the pipe.
- c_1 y c_2 : are constant coefficients.
- L : is the length of the pipe.
- d : is the diameter of the pipe.
- b : is the width of the excavation volume.
- h_{in} y h_{out} : are the depth of excavation at the upstream and downstream ends of the pipe.

The most common examples used in the literature for calculating these costs are the equations of Maurer et al. (2010) and Li and Matthew (1990), which are:

a. Maurer et al. (2010):

$$C = ((110d + 127)h + (1200d - 35))L \quad (2.9)$$

Where:

- C : is the cost of a pipe in U.S. dollars.
- d : is the diameter of the pipe in meters.
- h : is the average excavation depth of the pipe in meters.
- L : is the length of the pipe in meters.

b. Li y Matthew (1990):

$$f_p = \begin{cases} (4.27 + 93.59d^2 + 2.86dh + 2.39h^2)L & d \leq 1\text{m and } h \leq 3\text{m} \\ (36.47 + 88.96d^2 + 8.70dh + 1.78h^2)L & d \leq 1\text{m and } h > 3\text{m} \\ (20.50 + 149.27d^2 - 58.96dh + 17.75h^2)L & d > 1\text{m and } h \leq 4\text{m} \\ (78.44 + 29.25d^2 + 31.80dh - 2.32h^2)L & d > 1\text{m and } h > 4\text{m} \end{cases} \quad (2.10)$$

Where:

- f_p : is the cost of a pipe in yuan.
- d : is the diameter of the pipe in meters.
- h : is the depth of excavation of the pipe in meters.
- L : is the length of the pipe in meters.

ii- Cost of Manholes and Drop Manholes

The cost of a manhole or drop manhole is usually function of two variables: the diameter of the exiting pipe and the depth of excavation. Therefore, the general form of the equation would be:

$$C = c_1 + c_2 * h + c_3 * h^2 + c_4 * d + c_5 * d^2 \quad (2.11)$$

Where:

- C : is the cost of the manhole.
- c_1, c_2, c_3, c_4 y c_5 : are constant coefficients.
- h : is the depth of the manhole.
- d : is the diameter of the exiting pipe.

Some examples reported in the literature are:

a. Li y Matthew (1990):

$$f_m = \left\{ \begin{array}{ll} 136.67 + 166.19d^2 + 3.50dh + 16.22h^2 & \text{if } d \leq 1 \text{ m and } h \leq 3 \text{ m} \\ 132.91 + 790.94d^2 - 280.23dh + 34.97h^2 & \text{if } d \leq 1 \text{ m and } h > 3 \text{ m} \\ 209.74 + 57.53d^2 + 10.93dh + 19.88h^2 & \text{if } d > 1 \text{ m and } h \leq 4 \text{ m} \\ 210.66 - 113.04d^2 + 126.43dh - 0.60h^2 & \text{if } d > 1 \text{ m and } h > 4 \text{ m} \end{array} \right\} \quad (2.12)$$

Where:

- f_m : is the cost of a manhole in yuan.
 - d : is the diameter of the existing pipe in meters.
 - h : is the depth of excavation of the manholes in meters.
- b. Saldarriaga et al. (2023):

$$C = 4354.38 - 776.76h + 5404.52d - 6370.59hd + 870.05h^2 + 12820.76d^2 \quad (2.13)$$

Where:

- C : is the cost of the manhole in US dollars.
- d : is the diameter of the exiting pipe in meters.
- h : is the depth of excavation of the manhole in meters.

iii- Cost of Pumps and Pump Operations:

The costs of a pumping station, both construction and operation, depend on the flow rate, pumping head, energy cost (kW/h) and pump cost. The general form of a cost equation for a pumping station is, therefore:

$$C = c_1 * h + c_2 * h_p + (c_3 * \gamma * Q * h_p) * t * \frac{1}{\eta} \quad (2.14)$$

Where:

- C : is the pumping cost.
- c_1, c_2 y c_3 : are constant coefficients.
- h : is the depth of excavation of the pump.
- h_p : is the pumping head.
- Q : is the pumping flow rate.
- γ : is the gravity times the density of water.
- t : is the operating time of the pump.

- η : is the efficiency of the pump.

Some examples reported in the literature are:

- Cabral et al. (2018) and Saldarriaga et al. (2023): Cabral et al. (2018) equation represents pump construction costs, and Saldarriaga et al. (2023) equation represents operating costs. To use both equations together, the first equation was multiplied by $\frac{1000 \text{ €}}{\text{k€}} * \frac{1.1 \text{ USD}}{\text{€}}$, so that both equations are in dollars. The combination of both equations is presented below:

$$C = \left(e^{4.3184} * P^{0.5329} * \frac{1000 \text{ €}}{\text{k€}} * \frac{1.1 \text{ USD}}{\text{€}} \right) + \left(\frac{1}{\eta} * C_e * t * f_o * P \right) \quad (2.15)$$

Where:

- C : is the cost of the pump in US dollars.
- P : is the power in kW.
- η : is the efficiency of the pump.
- C_e : is the cost of energy in dollars per kilowatt hour.
- t : is the operating time in hours.
- f_o : is the fraction of the day the pump is in operation.

- Li y Matthew (1990):

$$f_s = 270,021 + 316,42q_s - 0,1663q_s^2 + \frac{85.848q_s h_s \psi}{\xi \eta} \quad (2.16)$$

Where:

- f_s : is the cost of the pump in yuan.
- q_s : is the pumping flow rate in liters per second.
- h_s : is the pumping head in meters.
- ψ : is the cost of energy in yuan per kilowatt hour.
- ξ : is the flow correction coefficient.
- η : is the efficiency of the pump.

2.5 Constraints

In the design of sewer networks, there are two types of constraints, some hydraulic and others constructive. Among the hydraulic constraints are: a minimum velocity and minimum shear stress, in order to ensure the self-cleaning of the sewer; a maximum velocity, in order to avoid problems of abrasion and stability of the pipes; a maximum filling ratio, in order to guarantee a free surface operation and a correct ventilation and gas extraction of the system. Usually, all these constraints are given by local standards or technical regulations. The constructive constraints are: a minimum diameter to ensure cleaning operations; a maximum diameter, which corresponds to the maximum diameter available in the local market; a minimum excavation, in order to guarantee a protection of the pipe with respect to overloads caused by traffic on the ground; a maximum depth to keep excavation costs within permissible limits; and the diameters available in the market for pipes, manholes, and drop manholes.

As an example of the constraints usually used in the literature, the constraints proposed by Li and Matthew (1990) are presented in Table 2.1.

Table 2.1. Constrains for sewerage systems.

Constraint	Value	Condition
Minimum diameter	0.2 m	Always
	0.6	$d \leq 0.3$ m
Maximum filling ratio	0.7	0.35 m $\leq d \leq 0.45$ m
	0.75	0.5 m $\leq d \leq 0.9$ m
	0.8	$d \geq 1$ m
Minimum velocity	0.7 m s ⁻¹	$d \leq 0.5$ m and flow rate > 0.015 m ³ s ⁻¹
	0.8 m s ⁻¹	$d > 0.5$ m and flow rate > 0.015 m ³ s ⁻¹
Maximum velocity	5 m s ⁻¹	Always
Minimum gradient	0.003	Flow rate < 0.015 m ³ s ⁻¹
Minimum depth	1 m	Always

Considering the problem's definition, size, cost functions, and constraints, the following chapters present the proposed methodology for the optimized design of sewer networks.

3. Sewer Network Layout Selection and Hydraulic Design Using a Mathematical Optimization Framework

Preamble

The paper presented in this Chapter 3, the first of a series of 4 papers, introduces a novel approach to solving the problem of optimized sewerage system design. As mentioned above, this problem was divided into two interconnected parts. On the one hand, there is the Layout Selection (LS), which aims to achieve a minimum cost design. On the other hand, the Hydraulic Design (HD) of the network once a layout has been determined. This division implies that the problem must be solved iteratively starting from a random layout.

Initially, a first optimized hydraulic design is made for the random layout using an algorithm based on the shortest path problem (Bellman-Ford algorithm) that allows obtaining a global minimum cost while complying with all the available hydraulic, construction, and piping constraints. The input variables for the HD are the flow rate of each pipe, available diameters, roughness, and hydraulic constraints. The cost equations used in this part of the methodology are a function of pipe diameter and excavation depth. With this design the next step is to return to the network layout problem, using a Mixed Integer Programming (MIP) model obtaining a cost equation based on flow rates. In this phase, the decision variables are the flow rate and flow direction in each pipe, with linear constraints describing the layout feasibility and a linear objective function that approximates the construction cost based on different layouts. For the LS, the input variables now are the cost equation, the topography of the terrain, and the inflow per manhole. This iterative process allows to achieve a better layout in each subsequent iteration, and this process continues until two successive iterations have very similar costs.

The reference of this paper is:

Duque, N.; Duque, D.; Aguilar, A.; Saldarriaga, J. Sewer Network Layout Selection and Hydraulic Design Using a Mathematical Optimization Framework. *Water* **2020**, *12*, 3337. <https://doi.org/10.3390/w12123337>

3.1 Introduction

A sewer network is an infrastructure that fundamentally comprises pipes and manholes, and is characterized by a network layout and a hydraulic design. The layout of a sewer network defines the flow direction within the network following a tree-like structure where all manholes are connected to the outfall through a unique path. Given a layout, a hydraulic design establishes the diameter for each pipe and the invert elevation of its two endpoints. The *sewer network design* (SND) problem aims to

obtain a minimum-cost design capable of transporting a specific flow rate for each pipe, while satisfying all hydraulic and operational constraints to comply with local regulations. The input information for the SND problem includes inflows at each manhole (rain and/or wastewater), topographic information, available pipe materials and diameters, density and water viscosity, and hydraulic design constraints.

Significant literature addresses the SND problem. The predominant approach to solve the problem considers the layout selection (LS) and hydraulic design (HD) as independent (and subsequent) problems. This separation allows for tractability of the problem at the price of design optimality. In what follows, we summarize some of the heuristic and exact techniques that have been proposed in literature to address the LS and HD problems.

A group of studies solve the HD problem for a given layout using mathematical programming (MP) approaches, such as linear programming (LP) [1–4]; non-linear programming (NLP) [5,6]; and dynamic programming (DP) [7–9]. A DP approach suffers from the problem of dimensionality in its application in the design of sewer systems [10]. To improve the dimensionality of DP-like approaches, Duque et al. [9] propose a graph modelling framework for the design of a series of pipes. The arcs of a graph model different combinations of invert elevations and diameters, a path represents a feasible hydraulic design and the best hydraulic design is obtained by means of a shortest path (SP) algorithm. Since these MP-based approaches can be computationally expensive, some authors use metaheuristics that provide a good solution with less computational resources. Genetic algorithms (GA) have been applied to water and sewer engineering problems to obtain least-cost designs [11–13]. Due to the high adaptability of GAs, they have also been used in combination with other models for sewer networks design. Cozzolino et al. [14] propose a combination with hydrologic and hydraulic models, Cisty [15] couples a GA with LP, Haghghi and Bakhshipour [12] with integer programming, and Hassan et al. [16] with heuristic programming (HP). Other heuristic approaches used to solve the hydraulic design problem are ant colony optimization (ACO) [17,18], simulated annealing (SA) together with tabu search (TS) [19,20], particle swarm optimization (PSO) [21], and cellular automata (CA) [22,23]. Zaheri et al. [24] implemented a two-phase simulation-optimization method to define iteratively the HD with CA while EPA SWMM is used to simulate the network. These heuristic strategies do not have optimality guarantees, and the burden to achieve globally optimal designs might be further expanded since the problem is solved sequentially.

Some authors have addressed the LS problem independently from the HD. This sub-problem is considered a hard problem that grows exponentially with the number of pipes. Walters [8] uses DP for optimizing the layout of a sewer network by selecting the position of all manholes along the trunk sewer after determining the order in which branches connect into it. Navin et al. [25] use Kruskal's algorithm to find the minimum spanning tree (MST) over a base graph in which edge lengths serve as the weights. From the MST, the authors generate a predefined number of trial spanning trees for the HD problem. Hsieh et al. [26] propose a Steiner minimal tree (SMT) problem solved with a mixed-integer programming (MIP) to select a layout. The objective function minimizes the buried depth of the pipes assuming that they represent the main construction costs in sewer systems. The construction cost for the pipes is simplified as a constant cost per unit length, which considers pipe and excavation costs. Moreover, the methodology uses fixed design parameters (e.g., Manning's roughness coefficient, filling ratio and minimum and maximum velocities) for the formulation of linear equations in the MIP. Some metaheuristics have also been used to solve the LS, such as GA [27,28] and ACO [29].

Haghighi [28] develops a loop-by-loop cutting algorithm in which he applied GAs for determining the near-optimal layout using graph theory. The loop-by-loop cutting algorithm has been successfully used to select those pipes of a base network that can be ‘cut’ to generate an open network layout. Later, Haghighi and Bakhshipour [20] use TS coupled with the loop-by-loop cutting algorithm for the optimization of the LS and HD. Other studies optimize both the layout and hydraulic design, yet in a sequential fashion. Moeini and Afshar [18,30] use a tree-growing algorithm (TGA) to generate layouts, ACO to determine pipe diameters and NLP to determine pipe slopes [31]. Navin et al. [32] use a combination of an MST for the layout selection and modified particle swarm optimization for the hydraulic design. Other approaches that sequentially solve both problems include [33–37]. In particular, Li and Matthew [34] are among the first authors to tackle both problems. Their method uses an SP spanning tree to obtain a first layout, diameters are derived from hydraulic principles, and invert elevations are computed using discrete differential dynamic programming (DDDP). The layout is iteratively improved using the search direction method that identifies pipes for which the flow rate can be adjusted to decrease the costs, while keeping the remaining pipe weights constant.

In this paper we propose an iterative method to solve the SND problem in which the network layout and the hydraulic design are computed with exact methodologies. Our method relies on MIP to obtain a network layout and uses DP to obtain a hydraulic design. The latter is an extension of the methodology proposed by Duque et al. [9] originally intended for series of pipes in sewer systems. An important feature of our methodology is that the mathematical model that describes each problem approximates the cost of a complete design using different but aligned objective functions. The objective function in the hydraulic design is a better representation of the real cost of a system because it is based on the diameters and invert elevations of the pipes, which are unknown in the LS problem. To circumvent this problem, our iterative scheme arises as a mechanism to refine an approximation of the objective function in the model for the LS problem by regressing previous layout decisions with their corresponding cost of the optimal hydraulic design. Refining the cost function approximation improves network layout in terms of the overall design cost, significantly reducing the optimality burden that arises from decoupling the problems.

Our methodology is novel with respect to previous literature in several aspects. For starters, *any* procedure for the layout selection relies on a surrogate for the cost function. For example, Navin et al. [25] use pipe lengths as a surrogate for the cost when computing the MST, while Hsie et al. [26] use ground cutting cost (expressed as a linear function of the invert elevations) plus a constant value that resembles the pipe cost per unit length. Our surrogate for the cost function approximates the construction cost of each pipe as a linear function of the flow direction and the flow rate, and the parameters of such functions are updated at every iteration. The simplicity of the cost function allows for a tractable model while the function updates help to guide the global search towards a near-optimal layout. Moreover, when solving the hydraulic design for a specific layout, there is a choice between solving for diameters and slopes sequentially or jointly. For example, Li and Matthew [34] fix pipe diameters based on design principles and solve a DP to define the crown elevations at the extremes of the pipes. Moeini and Afshar [18,30] use ACO to select diameters for each pipe and derive slopes assuming a maximum flow depth and a fixed elevation at the root node. Moeini and Afshar [31] extend the procedure in [18] and derive slopes by heuristically solving an NLP via BFGS¹ algorithm (see e.g., Nocedal and Wright [38] for BFGS optimality conditions). In contrast, our methodology jointly

¹ Broyden-Fletcher-Goldfarb-Shanno algorithm

optimizes both diameter and invert elevations with an exact method, i.e., for a fixed layout our hydraulic design is optimal. Lastly, we argue that our iterative scheme is unique across all methods discussed so far. Most heuristics rely on randomized procedures [18,30,31] or layout enumeration [25,32] to obtain different designs across iterations. Few authors incorporate a tabu list to guide the global search [30,31]. A notable exception is Li and Matthew [34] with their search direction algorithm, which essentially leverages the gradient of the objective function to update the current layout. Our approach is fundamentally different and proves effective to addressing the sewer design problem. To summarize our contributions:

- we propose an MIP to model the LS problem over a network with general topography,
- we extend the methodology in Duque et al. [9] to generate a hydraulic design, and
- we propose a novel iterative scheme in which the objective function in the LS model approximates the true hydraulic-based cost, and this approximation is refined as the method progresses.

Hereafter, the paper is organized as follows: the next section provides a rigorous description of the problem statement and defines key concepts that we use throughout the development of our methodology, and the subsequent section describes the proposed methodology in detail. Afterwards, two benchmark instances from the literature and one case study in Bogotá (Colombia) illustrate the performance of the methodology. Finally, the last section concludes the paper and outlines future research avenues.

3.2 Problem Statement and Definitions

In this section, we provide a formal problem statement of the LS and the HD, as well as the general design assumptions and terminology used in our methodology. Both problems are modelled using graph theory [39]. Each problem uses a particular graph representing different features of the network. The LS graph is connected to the HD graph through an auxiliary graph, the tree-structured graph, which translates the layout graph into an open network (Figure 3.1). The layout selection graph (top) represents the network topology and is based on manholes, pipes and an outfall. The tree-structured graph (middle) is the representation of the layout as a tree-like open network by using additional nodes to represent all the manholes at the extremes of the branches. Later, the hydraulic design graph (bottom) is built following the tree-structured graph's connectivity and generates a set of design nodes for each tree-node in the middle graph, which at the same time belongs to a manhole on the top graph. Design nodes are used to establish the position and dimensions of the pipes. Therefore, there are as many design nodes for one manhole as combinations of available pipe diameters and invert elevations. Possible invert elevations start at the minimum excavation limit and decrease based on a fixed elevation change (ΔZ), until the maximum excavation limit. The relationship between the graphs will be explained along with the mathematical formulation of the optimization framework.

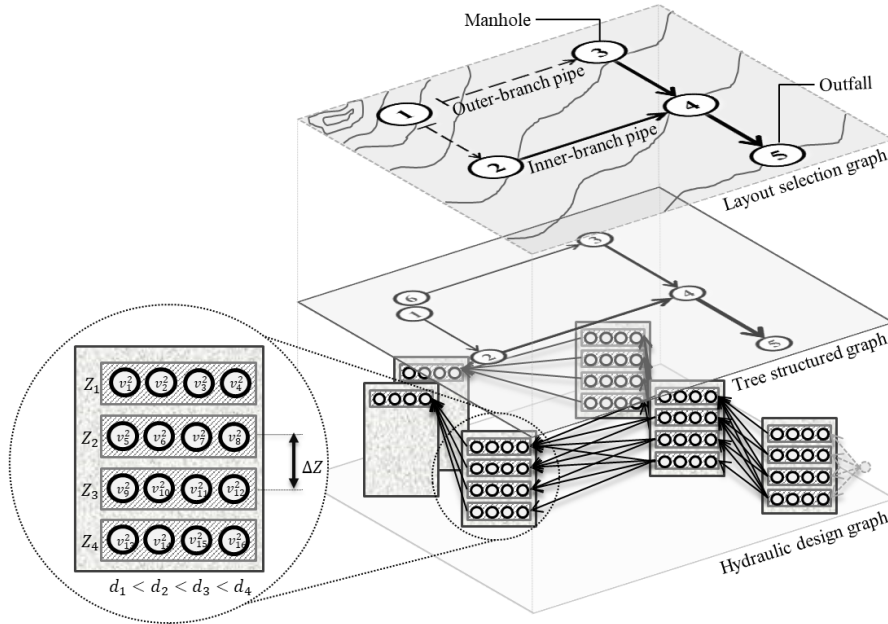

Figure 3.1. Relationship of the three sewer network design problem graphs. The layout selection graph (top) represents the network topology. The tree-structured graph (middle) is the representation of the layout as a tree-like open network by using additional nodes to represent all the manholes at the extremes of the branches. Finally, the hydraulic design graph (bottom) defines the hydraulic design options following the tree-structured graph's connectivity.

For both the LS and the HD, we made the following assumptions:

- The network must transport water from a discrete number of sources (manholes, sinks, etc.) to an outfall at a specific location [8].
- The flow moves by gravity over a tree-like structured network.
- There is a manhole between adjacent pipes due to changes in slope, diameter and/or flow direction [40].
- A uniform flow is assumed for the hydraulic design of each pipe [40].
- The HD methodology can use the Manning or Darcy–Weisbach and Colebrook–White resistance equations.

3.2.1 Layout Selection

The input of the LS problem can be described by an undirected graph $\mathcal{G} = (\mathcal{M}, \mathcal{E})$, where $\mathcal{M} = \{m_1, \dots, m_K\}$ is a set of nodes and $\mathcal{E} \subset \{(m_i, m_j) : m_i \in \mathcal{M}; m_j \in \mathcal{M}; i < j\}$ is a set of edges (undirected links between two nodes). Node $m_i \in \mathcal{M}$ represents the i -th manhole of the sewer network with the coordinates x_i and y_i and ground elevation Z_i . An edge $(m_i, m_j) \in \mathcal{E}$ represents the span between two manholes in which a pipe must be installed, but with no indication of flow direction. Individual inflows Q_i [m^3/s] enter the system at every manhole m_i and are transported through the pipes towards the outfall m_K .

For a layout to be feasible [28], (1) no cycles are accepted, (2) all manholes (nodes) must be connected to the outfall, (3) there must be a pipe on every edge, (4) there is a single outfall, (5) several

pipes can flow into a manhole, but at most one pipe can go out from every manhole, forming a unique directed path from every manhole to the outfall, (6) flow rates must satisfy mass balance equations at every manhole (no water is lost or stored).

Given the undirected base graph \mathcal{G} , a solution to the LS problem defines flow directions, flow rates, and connection types of every edge $(m_i, m_j) \in \mathcal{E}$ representing a sewer pipe. The flow direction of an edge determines whether the flow goes from m_i to m_j or otherwise. The flow rate of an edge resembles the flow rate of the respective pipe. The connection type of an edge describes the function of the pipes. The network is modelled as a tree-like structure with two types of pipe: inner-branch and outer-branch pipes (Figure 3.1). Through a series of pipes, each branch of the network follows a unique path towards the outfall. An outer-branch pipe is considered as the outmost pipe of a branch which receives, at most, the inflow from its upstream manhole. The inner-branch pipes are the rest of the pipes in the network. Outer-branch pipes do not have upstream pipes, while outer-branch and inner-branch pipes always drain into inner-branch pipes. We formally define the underlying directed graph that represents a sewer network layout later in our methodology.

3.2.2 Hydraulic Design

An HD defines the diameter and invert elevation of the endpoints of each pipe. This problem is represented by an additional graph as shown in Figure 3.1. The input data for the HD problem include the tree-like network layout, flow rates for each pipe, a cost function depending on the diameter and excavation depth, roughness of the pipe material (Manning or k_s coefficients), kinematic viscosity of the water, and some hydraulic and maintenance constraints. We consider the following hydraulic constraints: minimum pipe diameter, maximum filling ratio, minimum wall shear stress, minimum and maximum velocity, and minimum and maximum slope. For instance, upstream and downstream invert elevations of a pipe are chosen so that there is gravity-driven flow. For each manhole, there are as many design nodes as combinations of available pipe diameters and invert elevations. Possible invert elevations start at the minimum excavation limit and decrease based on a fixed elevation change (ΔZ), until the maximum excavation limit. To avoid blockages, every downstream pipe diameter is larger than or equal to its upstream pipe diameter.

3.3 Methodology

We propose an iterative optimization framework to solve the SND problem. At each iteration, we obtain a network layout using MIP and produce a hydraulic design using DP. The mathematical model that describes the LS problem consists of integer and continuous variables that represent layout decisions, linear constraints that define layout feasibility and a linear objective function that resembles the true cost of a system. The HD problem is framed as an SP problem on a graph that encodes both design decisions and constraints for a given network layout. A solution to the HD problem provides a better assessment of the true cost of a system than that obtained by the LS model; hence, we perform an extra step at each iteration in which the cost coefficients of the linear objective function in the LS model are updated based on all the network layouts seen so far and their corresponding construction costs obtained from the HD. This updating scheme relies on multiple linear regression models that regress the flow rate and flow direction of a pipe against its construction cost.

3.3.1 Layout Selection Model

To generate a network layout, we formulate an MIP [41] that models flow direction, flow rate, and connection type for every pipe of the sewer network. The model consists of decision variables that represent the flow rate and direction; linear constraints that mathematically describe the layout feasibility; and a linear objective function that approximates the construction cost of a complete design based on layout decisions. Our model is a variant of the network design problem [42] in which we incorporate additional constraints unique to sewer networks.

Recall that the input of the LS problem is given by the undirected graph $\mathcal{G} = (\mathcal{M}, \mathcal{E})$ and the inflow parameter Q_i for every manhole $m_i \in \mathcal{M}$. Let $\mathcal{T} = \{t_1, t_2\}$ be the set of connection types, with the understanding that t_1 represents outer-branch pipes and t_2 represents inner-branch pipes. Hence, layout decisions can be described by the following variables:

- x_{ijt} is a binary variable that takes the value of one if the flow direction between manholes m_i and m_j is from m_i to m_j and the connection is of type $t \in \mathcal{T}$.
- q_{ijt} is a nonnegative real-valued variable that represents the amount of flow from m_i to m_j if the connection type is $t \in \mathcal{T}$, in the same units as the inflow Q_i in each manhole m_i .

To fully describe a feasible layout with these decision variables, we require several constraints to couple them (e.g., if $x_{ijt} = 0$ we require that $q_{ijt} = 0$) and ensure feasibility as described in the problem statement (namely, a directed path from every manhole to the outfall node, a tree-like structure and mass balance at each node). To consider every possible layout, the model includes both x_{ijt} and x_{jit} variables for every edge $(m_i, m_j) \in \mathcal{E}$ and connection type $t \in \mathcal{T}$ (as well as q_{ijt} and q_{jit}). For the sake of correctness in our model, we define a set of arcs (directed links between two nodes) induced by set \mathcal{E} as $\mathcal{A}_L = \{(m_i, m_j) : (m_i, m_j) \in \mathcal{E}\} \cup \{(m_j, m_i) : (m_i, m_j) \in \mathcal{E}\}$, as well as indexed sets of outgoing pipes from manhole m_i , $\mathcal{M}_i^+ = \{j : (m_i, m_j) \in \mathcal{A}_L\}$, and incoming pipes to manhole m_i , $\mathcal{M}_i^- = \{j : (m_j, m_i) \in \mathcal{A}_L\}$. We set the parameter $Q_K = -\sum_{i=1}^{K-1} Q_i$ to represent the total flow in the system needing to reach the outfall node. To couple x_{ijt} and q_{ijt} with linear constraints, we define lower and upper bounds for variable q_{ijt} as $\ell_{ij} = Q_i/e_i$ and $u_{ij} = |Q_K|$, where e_i is the number of adjacent manholes to m_i . Finally, for every arc $(m_i, m_j) \in \mathcal{A}_L$ we define c_{ij} as an estimate of cost per flow unit that traverses from m_i to m_j and a_{ij} as a fixed cost estimate for selecting the flow direction $m_i \rightarrow m_j$. These parameters are incorporated in the objective function of the model which serves as an oracle of the true cost function of a complete design. Equation (3.1) defines the objective function that assesses the cost estimate of layout decisions.

$$\min \left(\sum_{t \in \mathcal{T}} \sum_{(i,j) \in \mathcal{A}_L} c_{ij} q_{ijt} + \sum_{t \in \mathcal{T}} \sum_{(i,j) \in \mathcal{A}_L} a_{ij} x_{ijt} \right) \quad (3.1)$$

Linear constraints (Equations (3.2)–(3.10)), ensure feasible connections throughout the network as well as proper water balance, assuming there are neither storage nor water losses. The mass balance constraint (Equation (3.2)) ensures that all the inflow gets transported and guarantees the existence of a unique directed path from every manhole to the outfall node.

$$\sum_{j \in \mathcal{M}_i^+} \sum_{t \in \mathcal{T}} q_{ijt} - \sum_{j \in \mathcal{M}_i^-} \sum_{t \in \mathcal{T}} q_{jit} = Q_i \quad \forall m_i \in \mathcal{M} \quad (3.2)$$

Equations (3.3) and (3.4) establish minimum and maximum flow rates for every pipe, respectively. Note that these two equations couple the decision variables x_{ijt} and q_{ijt} in a linear fashion, avoiding the product of x_{ijt} with q_{ijt} in the flow balance constraints. This is a relevant aspect of the formulation that allows for a computationally trackable model.

$$q_{ijt} \geq \ell_{ij} x_{ijt} \quad \forall (m_i, m_j) \in \mathcal{A}_L, t \in \mathcal{T} \quad (3.3)$$

$$q_{ijt} \leq u_{ij} x_{ijt} \quad \forall (m_i, m_j) \in \mathcal{A}_L, t \in \mathcal{T} \quad (3.4)$$

Equation (3.5) enforces a single flow direction and connectivity type for every pair of manholes $(m_i, m_j) \in \mathcal{E}$.

$$\sum_{t \in \mathcal{T}} (x_{ijt} + x_{jit}) = 1 \quad \forall (m_i, m_j) \in \mathcal{E} \quad (3.5)$$

Equation (3.6) ensures that at most one inner-branch pipe, $t_2 \in \mathcal{T}$, goes out of every manhole to ensure a tree-like layout.

$$\sum_{j \in \mathcal{M}_i^+} x_{ijt_2} \leq 1 \quad \forall m_i \in \mathcal{M} \setminus \{m_K\} \quad (3.6)$$

Equation (3.7) ensures that outer-branch and inner-branch pipes always drain into inner-branch pipes. By definition, an inner-branch pipe cannot drain into an outer-branch pipe. The left-hand side of this constraint counts the number of pipes going into manhole m_i . The right-hand side checks if an inner-branch type is going out (note that this sum is at most equal to one from the previous constraint). Hence, there can only be an inner-branch pipe going out of m_i , if other incoming pipes are selected.

$$\sum_{j \in \mathcal{M}_i^-} \sum_{t \in \mathcal{T}} x_{jit} \geq \sum_{j \in \mathcal{M}_i^+} x_{ijt_2} \quad \forall m_i \in \mathcal{M} \setminus \{m_K\} \quad (3.7)$$

Equation (3.8) states the maximum flow to be transported by an outer-branch pipe as the inflow coming from the upstream manhole.

$$\sum_{j \in \mathcal{M}_i^+} q_{ijt_1} \leq Q_i \quad \forall m_i \in \mathcal{M} \setminus \{m_K\} \quad (3.8)$$

Equations (3.9) and (3.10) define the mathematical domain of the variables.

$$q_{ijt} \geq 0 \quad \forall (m_i, m_j) \in \mathcal{A}_L, t \in \mathcal{T} \quad (3.9)$$

$$x_{ijt} \in \{0,1\} \quad \forall (m_i, m_j) \in \mathcal{A}_L, t \in \mathcal{T} \quad (3.10)$$

The optimization problem described above can be solved, i.e., obtain numerical values for x_{ijt} and q_{ijt} that minimize the objective function in Equation (3.1), via an off-the-shelf MIP solver (e.g., Xpress-MP Optimizer [43], Gurobi Optimizer [44]). The algorithm that solves such problems is beyond the scope of this paper, but we take for granted that we can retrieve from such solvers a numerical solution of x_{ijt} and q_{ijt} for every pair of manholes $(m_i, m_j) \in \mathcal{A}_L$ and connection type $t \in \mathcal{T}$ for which

the variables were defined. Note that a solution to the LS problem directly tells us where the network is open (i.e., forms a tree-like structured network) by scanning the resulting outer-branch pipes. We use x and q to denote vectors that contain all the decision variables x_{ijt} and q_{ijt} , respectively; and define \hat{x} and \hat{q} the numerical solution to the problem.

3.3.2 Layout Representation as a Tree-Like Directed Graph

Before jumping into the HD model, we describe a procedure that maps a layout described by \hat{x} to a tree-like directed graph denoted by $\mathcal{G}_T = (\mathcal{N}_T, \mathcal{A}_T)$. In this graph, there is one node for every manhole in \mathcal{M} , and there is one additional node for every outer-branch pipe in solution \hat{x} . To formalize this construct, let $\mathcal{N}_T = \{v_1, \dots, v_K, \dots, v_T\}$ be the set of tree nodes in graph \mathcal{G}_T , l_k be a label that represents the index of the manhole associated to tree node v_k , and $\mathcal{N}_T^i = \{v_k: v_k \in \mathcal{N}_T; l_k = i\}$ be a subset of \mathcal{N}_T that contains tree nodes associated with manhole $m_i \in \mathcal{M}$. Figure 3.1 (middle) shows an example of this at manhole $m_1 \in \mathcal{G}$ that is duplicated to obtain two nodes $v_1, v_6 \in \mathcal{N}_T^1$. These extra nodes resemble the upstream manhole of the outer-branch pipes in layout \hat{x} . The arcs of the network connect pairs of nodes in \mathcal{N}_T to resemble the layout decisions defined by \hat{x} . To avoid confusion with the nodes of graph \mathcal{G} , we henceforth refer to nodes in \mathcal{N}_T as tree nodes.

Tree nodes v_1, \dots, v_K have one-to-one correspondence with manholes m_1, \dots, m_K so that $l_k = k$ for $k = 1, \dots, K$ and nodes v_{K+1}, \dots, v_T have labels $l_k \in \{1, \dots, K\}$ for $k = K + 1, \dots, T$. To define the set of arcs \mathcal{A}_T , we consider connections of types t_1 (outer-branch) and t_2 (inner-branch) separately and define:

- $\mathcal{A}_T^{t_1} = \{(v_k, v_{k'}): k = K + 1, \dots, T; k' = 1, \dots, K; \hat{x}_{l_k, k', t_1} = 1\}$,
- $\mathcal{A}_T^{t_2} = \{(v_k, v_{k'}): k = 1, \dots, K; k' = 1, \dots, K; \hat{x}_{k, k', t_2} = 1\}$, and
- $\mathcal{A}_T = \mathcal{A}_T^{t_1} \cup \mathcal{A}_T^{t_2}$

3.3.3 Hydraulic Design Model and Solution Approach

Duque et al. [9] propose a methodology to solve the HD problem for sewer systems consisting of a single series of pipes. The key idea in their methodology is that finding the optimal hydraulic design is framed as an SP problem. In an SP problem, a directed graph is equipped with a cost function that assigns a weight to every arc, and the goal is to find a minimum-cost path between a pair of nodes. In the graph proposed by Duque et al. [9], a feasible design corresponds to a path in the graph that encodes diameter and invert elevation decisions for every pipe of the series. Nodes in this network span all combinations of diameters and discretized invert elevations at every manhole. An arc in this graph encodes a diameter and invert elevations for a specific pipe. To obtain an optimal design, costs are assigned to the arcs of the graph and an SP algorithm retrieves the minimum-cost path.

A network layout of general topology poses several modelling and algorithmic challenges to extend the methodology in Duque et al. [9]. The foremost of these challenges is that in a tree-like layout, because there are multiple starting points (outer-branch pipes), there are multiple paths that connect every manhole to the outfall that needs to be evaluated simultaneously. This is in contrast to the case in which a series of pipes is considered because there is only one starting point. Furthermore, manholes merge multiple pipes upstream into one inner-branch pipe downstream (see manhole 5 in Figure 3.1 for an example). The combination of these two issues hinders the possibility of applying a

one-to-one SP algorithm as in Duque et al. [9] because in our setting there are multiple starting nodes and the branch merging issue. Therefore, we found the individual shortest paths from the outfall to every outer manhole, and afterwards checked that the manholes with two or more incoming pipes would have an outgoing pipe at the lowest elevation.

The graph that represents all hydraulic designs for a given network layout requires input: a layout represented as a tree-structured graph \mathcal{G}_T , flow rates $\hat{\mathbf{q}}$, a discrete set of commercially available diameters $\mathcal{D} = \{d_1, \dots, d_B\}$, the roughness of the pipes (Manning coefficient or k_s), and the kinematic viscosity of water ν . The design flow rate $Q_{kk'}$ is obtained from the arcs in \mathcal{G}_T , which defines the design flow rate with magnitude [m³/s] and direction for every pipe in the network. Hence, $Q_{kk'} = \hat{q}_{ijt}$ for $i = l_k, j = l_{k'}$, and t is such that $x_{ijt} = 1$. To ease notation, we henceforth refer to the manhole associated with the tree node v_k by its index label l_k (as opposed to m_{l_k}).

In what follows, we first introduce an *HD graph* and then present the procedure for obtaining the optimal HD. Let $\mathcal{G}_D = (\mathcal{N}_D, \mathcal{A}_D)$ be a directed graph where nodes and arcs are defined as follows:

- $\mathcal{N}_D = \{v_1^1, \dots, v_i^k, \dots, v_{D^T}^T\}$ is the set of nodes in the HD graph \mathcal{G}_D , where v_i^k is the i th *design node* associated to the tree node $v_k \in \mathcal{N}_T$ and $v_{D^T}^T$ is the last design node in the outfall node $v_T \in \mathcal{N}_T$. Therefore, \mathcal{N}_D is the union of disjoint subsets $\mathcal{N}_D^k = \{v_1^k, \dots, v_{D^k}^k\}$ for every tree node $v_k \in \mathcal{N}_T$, i.e., $\mathcal{N}_D = \bigcup_{v_k \in \mathcal{N}_T} \mathcal{N}_D^k$.
- $\mathcal{A}_D = \left\{ \left(v_i^k, v_j^{k'} \right) : v_i^k \in \mathcal{N}_D^k, v_j^{k'} \in \mathcal{N}_D^{k'}, (v_k, v_{k'}) \in \mathcal{A}_T \right\}$ is the set of arcs of the HD graph \mathcal{G}_D .

Every node v_i^k is equipped with two attributes: $Z(v_i^k)$ represents a potential invert elevation in [m] at which a pipe can meet manhole l_k and $\delta(v_i^k)$ represents a possible diameter in [m] for an upstream pipe of manhole l_k . There are as many nodes in \mathcal{N}_D^k as combinations of diameters in \mathcal{D} and invert elevations at manhole l_k . The latter is determined by the excavation limits at manhole l_k and a discretization parameter ΔZ [m] selected by the user (e.g., 0.1 m or 0.01 m). The invert elevations that are considered for manhole l_k are $Z_{min}^k, Z_{min}^k + \Delta Z, Z_{min}^k + 2\Delta Z, \dots, Z_{max}^k$, where Z_{min}^k and Z_{max}^k denote the minimum and maximum invert elevations, respectively. Arc $(v_i^k, v_j^{k'})$ represents a pipe from manhole l_k to manhole $l_{k'}$ with diameter $d(v_i^k, v_j^{k'}) = \delta(v_j^{k'})$ and slope $s(v_i^k, v_j^{k'}) = \frac{Z(v_i^k) - Z(v_j^{k'})}{L(v_i^k, v_j^{k'})}$, where $L(v_i^k, v_j^{k'})$ is the pipe length (Figure 3.2). Note that both diameter and invert elevations for every pipe fully characterize a solution to the HD problem and, therefore, they represent the decision variables of the problem. In our formulation of the problem, these decision variables are ultimately mapped to the arcs in \mathcal{A}_D and their value is determined upon solving a shortest path problem as we explain next.

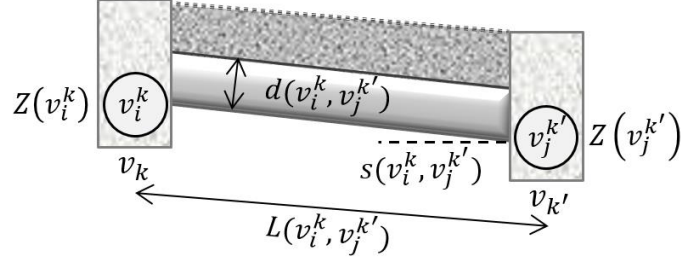

Figure 3.2. Hydraulic design representation of a single pipeline (diameter-slope) [9].

By construction, \mathcal{G}_D ensures that basic hydraulic constraints are met. For instance, if water flows from manhole l_k towards manhole $l_{k'}$, only arcs satisfying a non-decreasing diameter and a positive slope (in favour of gravity) exist. Formally, arc $(v_i^k, v_j^{k'})$ is part of graph \mathcal{G}_D if and only if $\delta(v_i^k) \leq \delta(v_j^{k'})$, $s(v_i^k, v_j^{k'}) > 0$, and all regulation-dependent constraints are satisfied. Note that typical hydraulic constraints such as minimum and maximum depth, flow velocity, shear stress and quasi-critical flow conditions, can be trivially evaluated for every arc $(v_i^k, v_j^{k'})$ because all the required input for the evaluation is known, i.e., diameter, slope, and flow rate ($Q_{kk'}$).

Every arc in \mathcal{A}_D is equipped with a cost $C(v_i^k, v_j^{k'})$ that represents the corresponding construction cost (and potentially maintenance and operational cost). In our case studies we adopt the cost function introduced by Li and Matthew [34], however, we emphasize that any cost function can be employed. Similar to how our model trivializes the evaluation of hydraulic constraints, highly non-linear cost functions are reduced to a parameter of the design graph. Most cost functions are defined in terms of pipe diameter $d(v_i^k, v_j^{k'})$, pipe length $L(v_i^k, v_j^{k'})$, and average excavation depth $h(v_i^k, v_j^{k'}) = 0.5 (h(v_i^k) + h(v_j^{k'}))$, where $h(v_i^k)$ is the buried depth at the extreme of a pipe, i.e., $h(v_i^k) = Z^k - Z(v_i^k)$.

To find an optimal hydraulic design for the given input layout, we solve a one-to-all shortest path problem on \mathcal{G}_D starting from a dummy node v_D that we connect to every node in \mathcal{N}_D^T (Figure 3.1 3.1). A solution to such a problem is a shortest path spanning tree \mathcal{P} rooted in v_D . Formally, the underlying optimization problem is defined by Equation (3.11)(3.11).

$$\min_{\mathcal{P}} \sum_{(v_i^k, v_j^{k'}) \in \mathcal{P}} C(v_i^k, v_j^{k'}) \quad (3.11)$$

Subject to \mathcal{P} being a shortest path spanning tree. The constraints that enforce \mathcal{P} to be a shortest path spanning tree are omitted as we adopt an algorithmic approach to solve the problem instead of a mathematical programming approach (as in the LS problem). A generic formulation of the SP problem can be found in Ahuja et al. [39]. We use the Bellman–Ford algorithm [45] to optimally solve problem ((3.11). The Bellman–Ford algorithm relies on labels at each node that save the cumulative cost from the starting node (v_D in our case). This label-correcting algorithm updates the cumulative cost for each node when a least-cost label is found and saves its predecessor node [39]. When all the nodes of the graph are evaluated, the cost labels are optimal. For more details about this algorithm, we refer the reader to Duque et al. [9].

When different series of pipes in the network have a common pipe, the solution of the one-to-all SP problem might include more than one arc between the manholes associated with the shared pipe. If that is the case, the final design is adjusted by choosing the inner-branch pipe with lower invert elevations (deeper pipe) and the largest diameter (e.g., pipe between tree layout nodes v_4 and v_5 in Figure 3.3). This adjustment ensures the design feasibility and does not compromise optimality since the selected pipe (deepest and largest in diameter) also belongs to the optimal solution of the one-to-all SP problem. The solution of this problem encodes the optimal hydraulic design of all the branches for a fixed input layout.

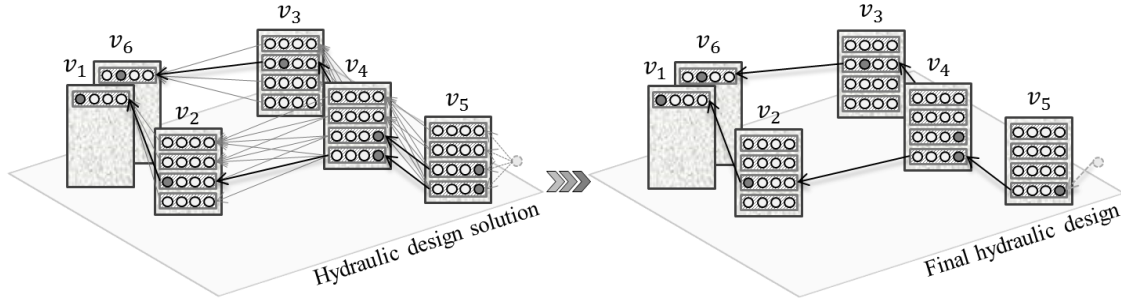

Figure 3.3. Selection of the definitive hydraulic design, eliminating double pipes generated from different shortest paths.

The entire procedure for the hydraulic design is summarized as follows:

1. Add a dummy design node v_D connecting every design node in the outfall \mathcal{N}_D^T (see Figure 3.1);
2. Assign a cost value $C(v_i^k, v_j^{k'})$ for every arc in \mathcal{A}_D ;
3. Reverse all arcs in \mathcal{A}_D and execute the Bellman–Ford algorithm [45] to obtain the one-to-all shortest paths from the outfall node v_D to every other node in \mathcal{N}_D ;
4. Retrieve the best paths from v_D to any design node in $\mathcal{N}_D^k \forall v_k \in \mathcal{N}_T$;
5. Select the deepest and largest diameter pipe when multiple design arcs $(v_i^k, v_j^{k'}) \in \mathcal{A}_D$ that are part of different shortest paths belong to the same tree arc $(v_k, v_{k'}) \in \mathcal{A}_T$, since only one pipe should exist in each section.

3.3.4 Iterative Scheme

We conclude our methodological section with a description of the iterative scheme and an outline of the entire algorithm. As mentioned, during a single iteration the LS and HD problems are solved in a sequential manner. Figure 3.4 summarizes the three modules and modelling frameworks for a single iteration.

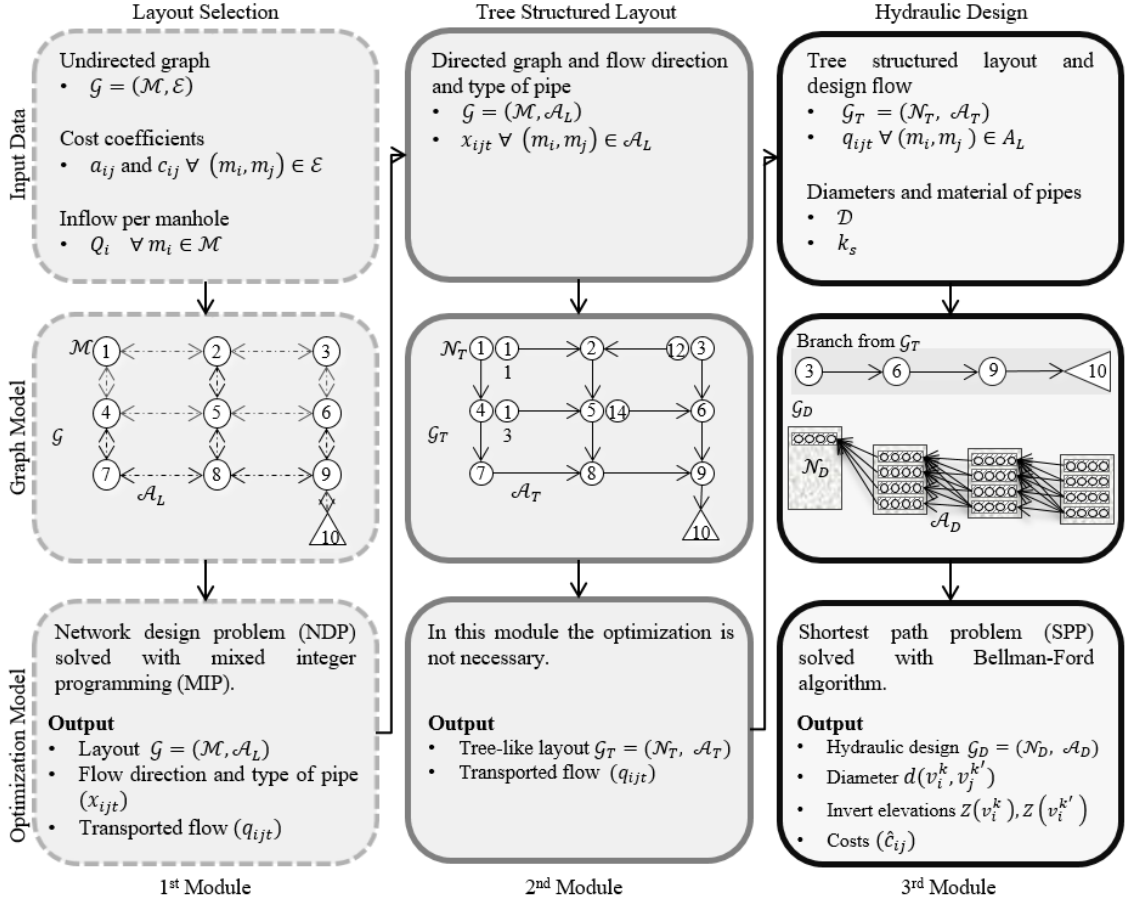

Figure 3.4. Sewer networks design (SND) modules and modelling frameworks for a single iteration.

Recall that the cost of a sewer network is a function of the diameter, length, and excavation volume of each pipe. However, diameters and excavation volumes are not decision variables of the LS problem and therefore the objective function (Equation (3.1)(3.1)) approximates the hydraulic design cost as a function of the flow rates \mathbf{q} and the flow direction \mathbf{x} . Equation (3.1) implies a linear model to approximate the cost of a pipe from manhole m_i to manhole m_j , as a function of q_{ijt} and x_{ijt} . Let \hat{c}_{ij} be a *prediction* of the cost of a pipe from m_i to m_j under the linear model in Equation (3.12).

$$\hat{c}_{ij} = c_{ij}q_{ijt} + a_{ij}x_{ijt} \quad (3.12)$$

Our goal is to estimate parameters c_{ij} and a_{ij} for all $(m_i, m_j) \in \mathcal{A}_L$ as a new input to the LS problem. We estimate c_{ij} and a_{ij} independently for each arc by means of linear regression. For a particular arc (m_i, m_j) , we regress previous values \hat{q}_{ijt} and \hat{x}_{ijt} against the cost obtained in the hydraulic design for this pair of manholes, i.e., $C(v, v')$ for some arc $(v, v') \in \mathcal{P}$ that belongs to the shortest path spanning tree for which nodes v and v' are associated to manholes m_i and m_j , respectively. Note that indices for v and v' were dropped to avoid cumbersome notation. As the algorithm progresses, we obtain new observations of \hat{c}_{ij} , q_{ijt} , and x_{ijt} that refine the estimation of the parameters. Refining the estimation ultimately improves the prediction of the cost and, therefore, the quality of subsequent layouts.

Figure 3.5 presents the entire framework in a flow diagram. We start with an initialization procedure that generates a hydraulic design based on a randomized layout. This step is necessary to obtain the observations for the parameter estimation in the regression step. The randomized layouts are obtained by simply assigning random values to c_{ij} and a_{ij} and solving the MIP model. In the iterative phase, the algorithm executes the three modules described above until a maximum number of iterations is met. After each iteration, the linear regression considers all the costs obtained from the hydraulic designs, providing a better estimate of the LS cost coefficients c_{ij} and a_{ij} .

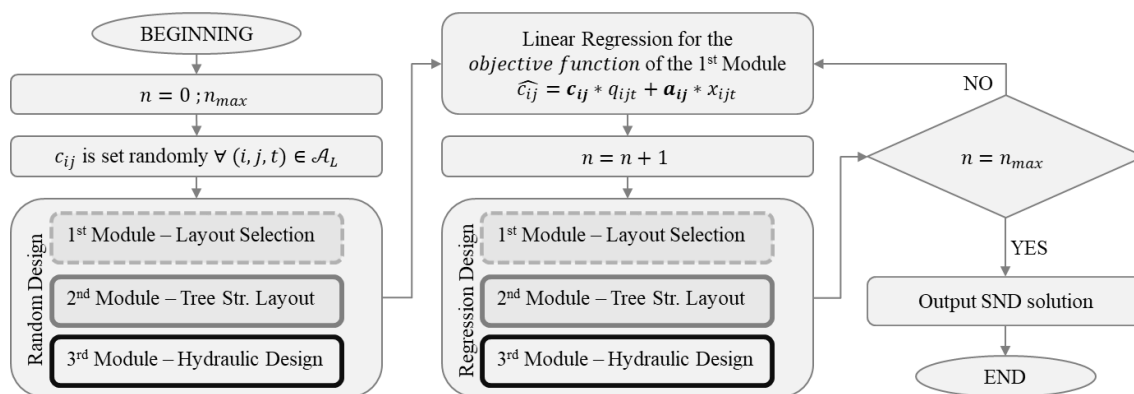

Figure 3.5. Sewer networks design (SND) problem flow chart.

3.3.5 Software and Data

The SND framework is mainly coded in Java. The layout selection module, however, is coded in Mosel, which is a mathematical modelling and programming language to model the MIP problem [43]. The SND software is available to download from [https://bitbucket.org/nduquevillarreal/snd_java-xpress.git](https://bitbucket.org/nduquevillarreal/snd_java-<u>xpress</u>.git). It was designed to have few data requirements for the design of sewer systems. We provide the input data of our case studies in the Supplementary Material.

3.3.6 Case Studies

To compare our approach to others found in the literature, we tested our methodology on two benchmark networks. The first benchmark, proposed by Li and Matthew [34], has 79 pipes and 78 manholes and has been used over the years by several authors to test their algorithms [4,12,46,47]. The second benchmark network proposed by Moeini and Afshar [31], has 81 manholes and 144 pipes. In addition, we also tested our methodology in a network that is part of the real sewer network in Bogota, Colombia. This network, labelled *Chicó*, has 109 manholes, 160 pipes with lengths between 65 m and 204 m, steep ground and a total flow of 1.526 m³/s. For the hydraulic design of these networks, we used the cost function, design parameters and constraints proposed by Li and Matthew [34]. Table 3.1 presents the hydraulic constraints and Equations (3.13) and (3.14) present the construction costs for a pipe f_p and a manhole f_m , respectively [34].

Table 3.1. Hydraulic design constraints for round pipes [34].

	Constraint	Value	Condition
1	Minimum diameter	0.2 m	Always
		0.6	$d \leq 0.3$ m
2	Maximum filling ratio	0.7	$0.35 \leq d \leq 0.45$ m
		0.75	$0.50 \leq d \leq 0.90$ m
		0.8	$d \geq 1.0$ m
3	Minimum velocity	$0.7 \frac{\text{m}}{\text{s}}$	$d \leq 0.5$ m
		$0.8 \frac{\text{m}}{\text{s}}$	$d > 0.5$ m
4	Maximum velocity	$5.0 \frac{\text{m}}{\text{s}}$	
5	Minimum gradient	0.003	Flow rate $< 0.015 \frac{\text{m}^3}{\text{s}}$

$$f_p = \begin{pmatrix} (4.27 + 93.59d^2 + 2.86dh + 2.39h^2)L & \text{with } d \leq 1 \text{ m and } h \leq 3 \text{ m} \\ (36.47 + 88.96d^2 + 8.70dh + 1.78h^2)L & \text{with } d \leq 1 \text{ m and } h > 3 \text{ m} \\ (20.50 + 149.27d^2 - 58.96dh + 17.75h^2)L & \text{with } d > 1 \text{ m and } h \leq 4 \text{ m} \\ (78.44 + 29.25d^2 + 31.80dh - 2.32h^2)L & \text{with } d > 1 \text{ m and } h > 4 \text{ m} \end{pmatrix} \quad (3.13)$$

$$f_m = \begin{pmatrix} 136.67 + 166.19d^2 + 3.5dh + 16.22h^2 & \text{with } d \leq 1 \text{ m and } h \leq 3 \text{ m} \\ 132.91 + 790.94d^2 - 280.23dh + 34.97h^2 & \text{with } d \leq 1 \text{ m and } h > 3 \text{ m} \\ 209.74 + 57.53d^2 + 10.93dh + 19.88h^2 & \text{with } d > 1 \text{ m and } h \leq 4 \text{ m} \\ 210.66 - 113.04d^2 + 126.43dh - 0.60h^2 & \text{with } d > 1 \text{ m and } h > 4 \text{ m} \end{pmatrix} \quad (3.14)$$

The variables f_p and f_m are calculated in terms of the pipe diameter d , the length L , and average buried depth h . The network construction cost is the sum of all costs of pipes and manholes in the network. Annual maintenance cost is 4.2% of the construction cost, considered for a 10-year period [34]. Construction and operational costs of pumping are not considered since our design considers gravity-driven systems. Additionally, we used concrete pipes (Manning coefficient $n = 0.014$ and the following list of diameters: {0.2, 0.25, 0.3, 0.35, 0.38, 0.4, 0.45, 0.5, 0.53, 0.6, 0.7, 0.8, 0.9, 1.0, 1.05, 1.20, 1.35, 1.4, 1.5, 1.6, 1.8, 2, 2.2, 2.4}).

The input data and detailed results for all networks can be found in the Supplementary Material and the Git repository. The input data includes the Id of the manholes and pipes, inflow Q_i in [m³/s] and the x , y and z coordinates in [m] at each manhole. The results for the hydraulic design for each pipe include upstream and downstream manhole, type [inner/outer], diameter [m], upstream and downstream invert elevation [m], flow rate [m³/s] and slope [-].

3.4 Results

3.4.1 Benchmark Li and Matthew [34]

After 10 iterations using an elevation change of $\Delta Z = 0.1$ m, the hydraulic design for this layout costs ¥ 1.33×10^6 and has a maintenance cost of ¥ 0.55×10^6 . The design has a maximum excavation depth of 9.45 m, and took a computational time of 45 min to solve both the LS and HD. An additional iteration was done to design the same layout with higher precision (i.e., a finer elevation change of $\Delta Z = 0.1$ m). Figure 3.6 shows the layout and hydraulic design obtained using $\Delta Z = 0.1$ m. The construction and maintenance costs were reduced to ¥ 1.29×10^6 and ¥ 0.54×10^6 , respectively. For

Table 3.2. Comparison of the construction cost for the benchmark proposed by Li and Matthew [34].

Method	Researchers	Optimized layout	Construction Cost (Yuan) $\times 10^6$
MGA	Pan and Kao [46]	No	¥ 1.91
Adaptive GA	Haghighi and Bakhshipour [12]	No	¥ 1.84
MILP	Safavi and Geranmehr [4]	No	¥ 1.57
SDE-GOBL	Liu et al. [47]	No	¥ 1.53
Loop-by-loop cutting algorithm and GA-DDDP	Haghighi and Bakhshipour [28]	Yes	¥ 1.59
Loop-by-loop cutting algorithm and TS	Haghighi and Bakhshipour [20]	Yes	¥ 1.43
Reliability - DDDP	Haghighi and Bakhshipour [48]	Yes	¥ 2.41
ACOA-TGA-NLP	Moeini and Afshar [31]	Yes	¥ 1.39
MIP and DP	(Present work)	Yes	¥ 1.29

Our layout could be improved with more iterations to gain a better approximation of the costs in terms of the flow and pipe direction. A non-linear cost approximation for the LS problem could also improve the results of the layout and, therefore, the entire sewer network design algorithm.

3.4.2 Benchmark Moeini and Afshar

We obtained a design for the benchmark network studied in Moeini and Afshar [31] that attains a total cost of ¥ 524,687 after 30 iterations of the algorithm, using an elevation change of $\Delta Z = 0.1 m$. Additionally, we conducted an experiment in which the layout is fixed to that of Moeini and Afshar [31] and solved only the hydraulic design problem. This design costs ¥ 569,334, using the same elevation change of $\Delta Z = 0.1 m$. Both scenarios assume the same constraints, cost function and conditions described in Li and Matthew [34]. Total costs include the construction costs and maintenance costs (Table 3.3). Column 1 describes the statistics of interest; column 2 shows the results reported in Moeini and Afshar [31], column 3 shows the results when we only apply the HD component of our algorithm on the layout reported by Moeini and Afshar [31]; and finally, column 4 shows the results of our algorithm.

Table 3.3. Comparison of the total cost for the benchmark proposed by Moeini and Afshar [31].

	ACOA-TGA-NLP [31]	DP (Present work) with fixed layout [31]	MIP and DP (Present work)
Costs			
Construction Cost	¥ 640,845*	¥ 400,940	¥ 369,498
Maintenance Cost	¥ 269,155*	¥ 168,395	¥ 155,189
Total Cost	¥ 910,000*	¥ 569,335	¥ 524,687
Computational effort			
Iterations [-]	10	1	30
Time [min]	198	4	115
Physical characteristics			
Average diameter [m]	0.331**	0.262	0.267
Average depth [m]	Not reported	2.07	1.95
Outfall diameter [m]	1.05**	0.7	0.8
Outfall depth [m]	Not reported	6.6	5.4

* Estimated from the reported total cost. ** Based on the reported design solution [31].

3.4.3 Real Network: Chicó

Figure 3.7 shows the layout obtained after 25 iterations using an elevation change of $\Delta Z = 0.1$ m. The hydraulic design for this layout uses the same constraints, cost function and conditions described in Li and Matthew [34]. The construction and maintenance costs are ¥ 699,097 and ¥ 293,621, respectively. Therefore, the total cost is ¥ 992,718. The design has a maximum excavation depth of 15.9 m and a diameter in the outfall of 1.05 m. All iterations took a computational time of 113 min to solve both the LS and HD. The detailed hydraulic design can be found in the Supplementary Material, as well as the distribution of the coefficient of determination R^2 of the linear approximation of the cost function for each pipe after 25 iterations. The average R^2 is 0.84, with a standard deviation of 0.23. The R^2 across all the individual linear regressions varied from a minimum of 0.004 and a maximum of 1. Pipes with $R^2 = 1$ represent those pipes that had the exact same design along the iterations.

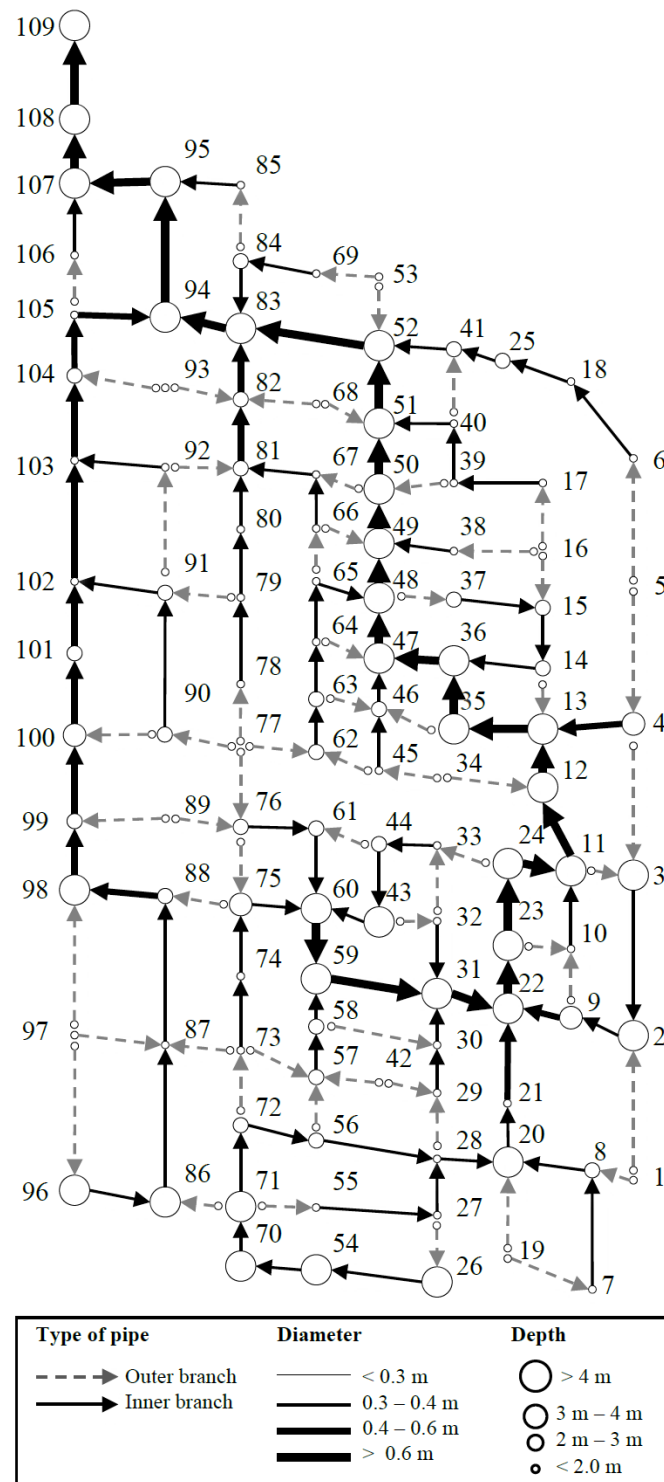

Figure 3.7. Layout and hydraulic design of Chicó sewer network.

3.4.4 Convergence Curves

We close this section with a convergence analysis of the algorithm. For each case study, Figure 3.8 shows the construction cost of the sewer network design obtained at each iteration of our algorithm. Our algorithm behaves somewhat similarly across the three case studies. The first design leads to a relatively high cost due to a poor initial layout that is obtained with random coefficients in

Equation (3.1). However, all subsequent iterations benefit from the cost function approximation that is employed in the LS problem. Moreover, as the algorithm progresses, the cost function approximation is refined with new hydraulic design solutions that populate the linear regression. In short, these convergence curves highlight a core component of our framework that enables the HD problem to provide feedback to the LS problem.

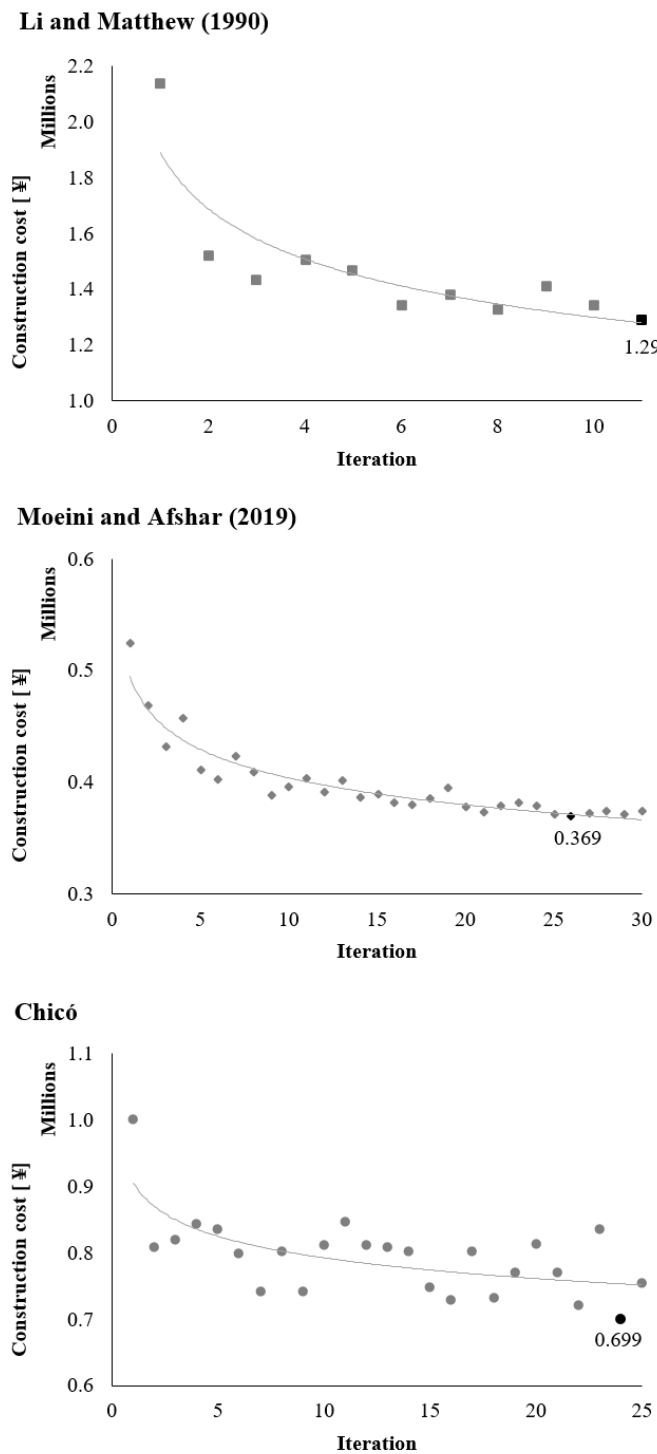

Figure 3.8. Convergence curves for each case study concerning construction costs.

3.5 Discussion

For all case studies, the proposed methodology found a better solution than those reported in the literature. These are near-optimal solutions with respect to construction cost that satisfy all hydraulic constraints and ensure feasible pipe connections in a sewer system. The LS is modelled as an MIP and is solved exactly (for a particular objective function approximation) with an off-the-shelf optimization solver. The cost function approximation for the LS problem is enhanced by the results of new hydraulic designs, as shown with the convergence curves in Figure 3.8. Hydraulic design solutions of previous iterations are used as additional data points in a linear regression model that estimates construction costs as a linear function of the flow rate and the flow direction. These solutions are not intended to be the global optimal solution for the network design, since the layout selection problem uses a proxy for construction costs that might not be the best approximation of the cost. Nevertheless, once a near-optimal layout is selected, we obtained an optimal hydraulic design for the specific near-optimal layout. As expected, during the first iterations, there is a big improvement of the LS cost function and then the algorithms start to converge to a constant value. The minimum cost hydraulic design represents the best layout obtained for that network within the number of iterations or accepted tolerance for the design.

The comparison of all the results obtained by different authors (Table 3.2) over the well-known benchmark proposed by Li and Matthew [34] shows that our methodology obtains the best cost, even if the layout optimization is not optimal. Some authors used the exact same layout proposed by Li and Matthew [34] and only solved the hydraulic design problem with the best result cost ¥ 1.53×10^6 using the self-adaptive differential evolution algorithm [47]. Later researchers tackled the LS problem as well, aiming for better results for the final hydraulic design. Previously, the best solution for both the LS and HD problems cost ¥ 1.39×10^6 using ACOA-TGA-NLP [31]. Our methodology shows a big improvement by saving up to 16% of the costs compared to the lowest cost found in the literature, with a final cost of ¥ 1.29×10^6 .

Regarding the results for the second benchmark proposed by Moeini and Afshar [31] presented in Table 3.3, we obtained up to 37% savings on the HD using Moeini and Afshar's layout, and up to 42% savings when solving both the LS and HD with our approach. As expected, we have a high computational effort given that our methodology makes an exhaustive search among all possible design combinations. Nonetheless, the computational time spent by our algorithm was lower than the result obtained using ACOA-TGA-NLP [31]. Therefore, we can say that our computational time is acceptable considering the improvement we obtain in the total construction cost. The last case study was proposed as a new benchmark using a network with real topographic data with mild slopes.

Our methodology can be improved by getting a better proxy for the cost function used to solve the LS problem. The current cost function is obtained through a linear regression of previous design options for the network. A non-linear cost approximation for the LS problem could also improve the results of the layout and, therefore, the entire sewer network design algorithm. This improvement might also have a positive impact on the computational time required to obtain a near-optimal sewer network design.

3.6 Conclusions

We proposed a mathematical optimization framework for the design of sewer networks, with the objective of minimizing construction costs while ensuring proper performance of the sewer network. A graph modelling framework was proposed to represent the different features of a sewer network design. The layout selection graph (Figure 3.1) represents the type and flow direction of each pipe that are the decision variables for the LS problem. A second graph represents the layout as an open network, with a tree structure that avoids loops. The last graph represents the hydraulic design problem, modelling the diameters and invert elevations of the pipes.

The LS is modelled as an MIP, which is solved for a particular objective function with an off-the-shelf optimization solver. The objective function approximation is enhanced by new hydraulic design solutions, which are used as additional data points in a linear regression model that estimates construction costs as a linear function of the flow rate and the flow direction. On the other hand, the extension of the hydraulic design methodology proposed by Duque et al. [9] ensures the global optimal hydraulic design for the given layout and design conditions. The iterative scheme significantly reduces construction costs during the first iterations and it encounters a near-optimal solution as the algorithm progresses. Better approximations of the real cost function for the layout selection model might translate into further improvement of the overall design. Moreover, the method can be extended to consider pumping stations for flat terrain by using additional arcs in the design graph.

Since the size of the problem increases exponentially with the number of pipes in the network, there is a computational capacity burden in that fewer iterations can be executed for large-scale networks. Future research is needed to formulate better cost function approximations for the layout selection (e.g., non-linear functions) to produce a better representation of the construction cost in this stage of the design. Furthermore, our methodology could leverage parallel computing to speed up certain components of the framework such as the hydraulic design.

Supplementary Materials: The following are available online at www.mdpi.com/2073-4441/12/12/3337/s1, Table S1: Input data Benchmark proposed by Li and Matthew [34]. The exact x and y coordinates are not defined, however the length of the pipes is known, Table S2: Hydraulic design for the Benchmark proposed by Li and Matthew [34], Table S3: Input data Benchmark proposed by Moeini and Afshar [31], Table S4: Hydraulic design for the Benchmark proposed by Moeini and Afshar [31], Table S5: Input data for the manholes of Chicó's sewer network (109 manholes), Table S6: Hydraulic design for the Benchmark Chicó, Figure S1: Coefficient of determination R2 of the linear approximation of the cost function for each pipe in Chicó case study after 25 iterations, Figure S2: Global fitness of the linear approximation of the cost in terms of the flow rate.

Author Contributions: Conceptualization, N.D., D.D. and J.S.; Software, N.D. and D.D.; Validation, N.D. and A.A.; Formal Analysis, N.D., D.D., A.A. and J.S.; Writing—Original Draft Preparation, N.D., D.D., A.A. and J.S.; Writing—Review and Editing, N.D., D.D., A.A. and J.S. All authors read and approved the final manuscript. All authors have read and agreed to the published version of the manuscript.

Nomenclature

Layout Selection

- \mathcal{G} is the graph that represents the layout selection problem.
- \mathcal{M} is the set of nodes representing manholes.
- \mathcal{E} is the set of undirected edges representing links between two nodes $m_i \in \mathcal{M}$ and $m_j \in \mathcal{M}$.

- Q_i is the inflow at manhole $m_i \in \mathcal{M}$.
- Q_K is the total flow in the system reaching the outfall manhole $m_k \in \mathcal{M}$.
- Z_i is the ground elevation at manhole $m_i \in \mathcal{M}$.
- \mathcal{T} is the set of possible types of pipes, containing outer-branch pipes (t_1) and inner-branch pipes (t_2).
- \mathcal{A}_L is the set of *directed* links between two manholes, m_i and m_j , so that $(m_i, m_j) \in \mathcal{E}$. x_{ijt} is the binary decision variable that represents the flow direction and connection type in the network layout, for all $(m_i, m_j) \in \mathcal{A}_L$ and $t \in \mathcal{T}$.
- q_{ijt} is the continuous decision variable that represents the flow through arc (m_i, m_j) of type t , for all $(m_i, m_j) \in \mathcal{A}_L$ and $t \in \mathcal{T}$.
- M is a large positive number.

Tree-structured Layout

- \mathcal{G}_T is the graph that represents the selected layout as a tree-structured network.
- \mathcal{N}_T is the set of nodes in the tree-structured graph \mathcal{G}_T .
- l_k is a label that represents the index of the manhole associated to tree node $v_k \in \mathcal{N}_T$.
- \mathcal{N}_T^i is a subset of \mathcal{N}_T that contains tree nodes associated with manhole $m_i \in \mathcal{M}$.
- \mathcal{A}_T is the set of arcs in the tree-structured graph \mathcal{G}_T .

Hydraulic Design

- \mathcal{G}_D is the auxiliary graph used to represent the hydraulic design problem.
- \mathcal{N}_D is the set of nodes in the hydraulic design graph \mathcal{G}_D , which is divided in subsets of nodes \mathcal{N}_D^k related with the tree node $v_k \in \mathcal{N}_T$.
- \mathcal{A}_D is the set of arcs of the hydraulic design graph \mathcal{G}_D .
- \mathcal{D} is the discrete set of commercially available pipe diameters.
- $\delta(v_i^k)$ is the discrete decision variable that represents a possible diameter for an upstream pipe of tree node $v_k \in \mathcal{N}_T$ and manhole l_k .
- $Z(v_i^k)$ is the continuous decision variable that represents the elevation above a reference level of a node of the graph \mathcal{G}_D .
- s is the slope for each pipe, fully determined by the invert elevations $Z(v_i^k)$ and $Z(v_j^k)$ at the extremes of the arc $(v_i^k, v_j^k) \in \mathcal{A}_D$ which represents a pipe.
- k_s is the absolute roughness of the pipes.

4. Layout Selection for an Optimal Sewer Network Design Based on Land Topography, Streets Network Topology, and Inflows

Preamble

This Chapter 4 contains the second article on the subject of optimized design of sewerage systems, understood as the design of minimum construction cost. The general methodology followed for this purpose is based on dividing the optimization problem into two parts. The first is the network layout or tree and the second is the hydraulic design. An iterative process was carried out starting with a random layout from which a first hydraulic design of minimum global cost for that layout was developed by means of a shortest path algorithm. Then, with that design, a layout was chosen again using a Mixed Integer Programming algorithm. Although the results were good, yielding lower costs than those reported in the literature, the process required high computational times and could yield strange topological results; for example, some sections could have flow direction against the slope of the terrain. In order to solve these two problems, a new methodology was developed to improve the accuracy of the objective function of the layout selection model. The new strategy is based on the known information related to the design of a sewer network: the inflow per manhole, the urban layout of streets and roads, and the topography of the terrain. Based on this information using geometric criteria (i.e., path length, distance to the outlet, etc.), hydraulic criteria (i.e., inflow per manhole), and hydraulic power criteria (i.e., flow per path length; flow per head difference), it was possible to solve the layout selection (LS) problem with a very low computational effort while achieving lower costs than those found using the previous methodology. The costs obtained are the lowest among those reported in the literature for standard sewer networks.

The reference of this paper is:

Saldarriaga, J.; Zambrano, J.; Herrán, J.; Iglesias-Rey, P.L. Layout Selection for an Optimal Sewer Network Design Based on Land Topography, Streets Network Topology, and Inflows. *Water* **2021**, *13*, 2491, doi: <https://doi.org/10.3390/w13182491>.

4.1 Introduction

The design of an urban drainage system is a process that can be divided into two components: layout selection and hydraulic design. The objective of the layout selection is to determine the type, direction, and flow rate of each pipe. This is commonly defined by the designer's experience based on the area topography [1]. The above implies that the process of selecting the layout is subjective and lacks any optimization method or criterion that allows guaranteeing low-cost solutions. For the hydraulic design, once the layout has been obtained, each pipe is designed with the combination of diameter and slope that allows the flow rate to comply with operational and hydraulic restrictions

established by local regulations. Each of these components is a problem that has different variables, constraints, and input data, which makes it difficult to have a single methodology to solve both processes.

The problem of sewer network design optimization was first proposed in the mid-1960s [2], and historically, each component of the problem, i.e., the layout selection and hydraulic design, has been addressed independently. For the hydraulic design, the literature shows that different methodologies have been developed using mathematical programming (MP), among which are linear programming (LP) [3–8], nonlinear programming (NLP) [2,9–11], and Dynamic Programming (DP) [12–16]. Recently, Duque, Duque, and Saldarriaga [17] proposed a methodology using dynamic programming, where pipes and manholes are modeled with graph theory, and the problem is solved using a shortest path algorithm that finds a globally optimal solution for a given cost function.

Because of the high computational capacity that mathematical programming requires, metaheuristics have been widely used. Among the most popular techniques are genetic algorithms (GA) [18–22], ant colony optimization (ACO) [23–25], particle swarm optimization (PSO) [26], cellular automata (CA) [27], tabu search (TS), and simulated annealing (SA) [28–30]. Other variations of genetic algorithms were proposed with linear programming [31], quadratic programming [32], integer programming [20], and heuristic programming (HP) [33]. Although metaheuristics are efficient with computational time, there is no guarantee of optimality in their solutions.

For the layout selection, Li and Matthew [34] proposed one of the first studies that were very successful. Their methodology solved the two components of sewer networks' optimal design through the searching direction method for the layout selection and discrete differential dynamic programming (DDDP) for the hydraulic design. In addition, to test their methodology, the authors proposed a theoretical sewer network that would become a benchmark studied to this day by researchers interested in the optimal sewer network design. This sewer network was tested again by Haghighi [35], who proposed to solve the layout selection problem with an algorithm called the loop-by-loop cutting algorithm, based on graph theory, where the sewer network is represented as a graph with undirected loops and relies on genetic algorithms for better results.

Subsequently, the methodology was completed by Haghighi and Bakhshipour [28], who integrated the loop-by-loop cutting algorithm with the resolution of hydraulic design using TS. Other methodologies were developed for the layout selection, such as DP [15], GA [22,36], ACO [37], tree growing algorithm (TGA) [24,25], hanging gardens algorithm (HGA) [38], and heuristic approaches [39–42]. Research into the optimized design of urban drainage networks has grown in such a way that some authors, such as Bakhshipour, Hespén, Haghighi, Dittmer and Nowak [43], have incorporated other optimization criteria, such as resilience into their methodology. Moreover, in the last few years, some authors have been using LID methodologies to help in the optimal design of sewer networks, especially in relation to peak discharges reduction [44].

Recently, Duque et al. [45] proposed an iterative methodology to sequentially solve both components of the sewer network design optimization problem. First, the layout selection is solved with mixed-integer programming (MIP). Then, the result of this model enters as a parameter of the hydraulic design model, which is solved with a shortest path algorithm. Both models are embedded into an iterative scheme that improves the cost function of the layout selection model upon learning

the actual design cost of the hydraulic design model. The methodology was applied to three case studies, one of which is the sewer network proposed by Li and Matthew [34], where the lowest cost reported in the literature was obtained.

The present research is an extension of the methodology proposed by Duque et al. [45] and proposes a new strategy to improve the accuracy of the layout selection model objective function. The strategy is based on the known information regarding a sewer network design: the inflow in each manhole, the urban streets and avenues topology, and the land topography. With a novel use of this information, we were able to solve the layout selection model with less computational effort and also obtain hydraulic designs with lower construction costs in comparison to the methodology of Duque et al. [45] and other methodologies proposed in the literature.

4.2 Background

Since the present work suggests an extension to the methodology proposed by Duque et al. [45], the section of background briefly describes what this methodology consists of.

In the layout selection problem, Duque et al. [45] use MIP to model the drainage system as a network design problem that defines the flow direction, flow rate, and connection type of each pipe that conforms to the sewer network.

The input of the model is an undirected graph composed by a set of nodes $\mathcal{M} = \{m_1, \dots, m_K\}$ that represent the manholes of the sewer network, and a set of edges $\mathcal{E} \subset \{(m_i, m_j): m_i \in \mathcal{M}; m_j \in \mathcal{M}; i < j\}$ that refer to the undirected connection between two nodes. It is also known the coordinates x , y , and z and the inlet flow from each manhole. Further, in order to model the directed links between two nodes, that is, pipes with a defined flow direction, a set of arcs is established from the set \mathcal{E} . This set is defined as $\mathcal{A}_L = \{(m_i, m_j): (m_i, m_j) \in \mathcal{E}\} \cup \{(m_j, m_i): (m_i, m_j) \in \mathcal{E}\}$.

For a layout to be feasible, it cannot allow the recirculation of water through the pipes. For this reason, a tree-shaped structure is required, that is, a network composed of several series of pipes with a single discharge. In order to achieve this structure, two types of pipes are used, outer-branch and inner-branch. An outer-branch pipe is considered to be the first pipe in a series and receives inflow only from its upstream manhole. On the contrary, inner-branch pipes are the rest of the pipes in a series. In the model, the pipe type is represented by the $\mathcal{T} = \{t_1, t_2\}$, where t_1 represents an outer-branch pipe and a t_2 an inner-branch pipe. Figure 4.1 shows a scheme of outer and inner branch pipes.

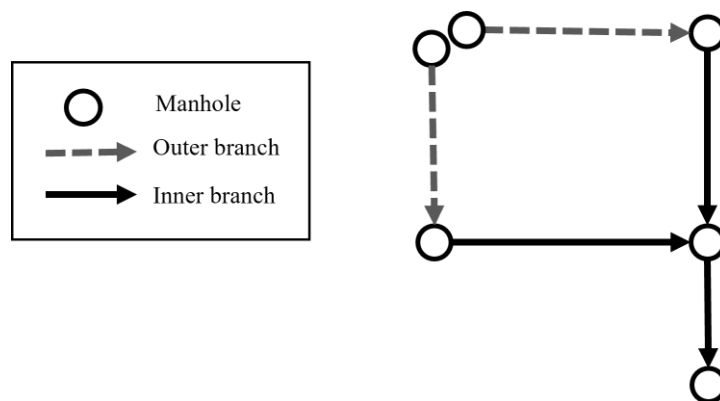

Figure 4.1. Types of pipes in the sewer network.

The methodology has two decision variables: x_{ijt} , a binary variable that takes the value of one (1) if the pipe from m_i to $m_j \in \mathcal{A}_L$, that is of type $t \in \mathcal{T}$, is part of the layout solution; and q_{ijt} , a non-negative real variable that represents the flow rate in the pipe of type $t \in \mathcal{T}$ that goes from m_i to $m_j \in \mathcal{A}_L$.

Lastly, the decision variables are multiplied by two cost coefficients in the objective function. These coefficients are c_{ij} , which represents the estimated cost per flow unit that passes through the pipe from m_i to m_j ; and a_{ij} , which describes the cost associated with using a pipe with flow direction m_i to m_j . These costs are estimated by a linear regression that is updated with the costs obtained in the hydraulic design model. Duque et al. [45] propose an iterative scheme between the layout selection model and the hydraulic design model, in which the accuracy of the cost function of the layout selection is improved with each iteration. The disadvantage of this iteration scheme is that it requires random values of c_{ij} and a_{ij} to start the process, and this affects the convergence of the algorithm.

The estimated cost of the layout selection model is minimized by Equation (4.1), which considers flow rate, flow direction, and pipes required. The weakness of this objective function is that it does not include the land topography criterion. This can cause the selection of layouts that do not match the land slope, especially in non-flat areas.

$$\min \left(\sum_{t \in \mathcal{T}} \sum_{(i,j) \in \mathcal{A}_L} c_{ij} q_{ijt} + \sum_{t \in \mathcal{T}} \sum_{(i,j) \in \mathcal{A}_L} a_{ij} x_{ijt} \right) \quad (4.1)$$

According to Haghghi and Bakhshipour [1] (p. 790), “in the case of steep basins, based on engineering judgments it is almost possible to create a cost-effective layout”, this is, for sewer networks located in steep topography, an engineer can be guided by the natural land slope to define a feasible and cost-effective layout. However, the design of the layout is subjective and depends on the engineer’s experience, especially in flat topography, where it is not easy to be guided by the natural land slope. Therefore, several layout proposals are possible, each one of them with its own different cost, some of them being cheaper than others. In addition, there are many engineering criteria to create the layout, such as: pipes with higher natural slope, pipes with a greater difference of elevation between manholes, distance to discharge, number of outer-branch pipes. Therefore, whether steep

topography or not, it is necessary to have a methodology that considers all the components involved in the layout selection problem.

This research proposes a methodology as an extension of the mathematical optimization framework proposed by Duque et al. [45], which seeks to solve the layout selection problem taking into account all the data known in this problem, i.e., land topography, streets network topology, and inflow to each manhole. This is in order to eliminate the subjectivity of the layout selection cost function, to obtain a more general methodology that could be applied to sewer networks with any type of topography, and to decrease computational effort.

4.3 Methodology

The present methodology proposes some changes to the objective function of the layout selection model proposed by Duque et al. [45]. First, it is proposed to add a term to the equation that models the land topography. This term is presented in Equation (4.2), where is a coefficient that depends on the land topography in the pipe from m_i to $m_j \in \mathcal{A}_L$ of type $t \in \mathcal{T}$.

$$\sum_{t \in \mathcal{T}} \sum_{(i,j,t) \in \mathcal{A}_L} b_{ijt} x_{ijt} \quad (4.2)$$

Another change proposed by the methodology is the way the coefficients c_{ij} and a_{ij} are calculated, since Duque et al. [45] propose an estimation with linear regression, but the relation between construction cost and flow rate is not linear. To define the new values of the coefficients b_{ijt} , c_{ij} , and a_{ij} the methodology proposes two stages: the selection of an initial layout and an iteration with penalties in excavation. This section explains those stages.

4.3.1 Selection of an Initial Layout

To determine the value of the coefficients b_{ijt} , c_{ij} , and a_{ij} an initial hydraulic design is required, and therefore, an initial layout. Duque et al. [45] propose a random initial layout, but this affects the convergence of the method. Hence, the present methodology proposes a method to determine an initial layout close to the optimal one based on engineering criteria.

The method assigns a weight b_{ijt} to each pipe, which will be a large value for nonefficient pipes and, therefore, a small value for the pipes that are desirable on the layout. Equation (4.3) defines the objective function of the initial layout, which minimizes the sum of the weights assigned to the pipes in order to select those with the lowest weight.

$$\min \left(\sum_{t \in \mathcal{T}} \sum_{(i,j,t) \in \mathcal{A}_L} b_{ijt} x_{ijt} \right) \quad (4.3)$$

Considering that pipes and land slope should be in the same direction in order to avoid increments in excavation depths, three criteria were proposed to define the value of the coefficient b_{ijt} .

4.3.1.1 Criterion 1

This criterion seeks to give priority to the pipes with the same direction of the land slope by multiplying the slope of the pipe by -1 . In this way, the pipes that are against the slope will have a positive b_{ijt} and will be discarded from the layout since the objective function is to be minimized.

Furthermore, this criterion seeks to minimize the number of outer-branch pipes; therefore, a penalty coefficient μ is assigned to this type of pipe. In order to make the outer-branch pipes less desirable for the layout selection model, the value of μ should be a number between 0 and 1 for outer-branch pipes with positive slopes and a value greater than 1 for outer-branch pipes with negative slopes.

To select the most appropriate value of μ for positive and negative slopes, a sensitivity analysis was performed. In the analysis, the value of μ for positive slopes ranged between 0.2 and 0.8, while for negative slopes, it ranged between 1.05 and 1.95. Different combinations were tested with these values, and it was concluded that a recommended combination is 0.65 for positive slopes and 1.65 for negative slopes since designs with the lowest costs were obtained with these values. However, if another combination of values of μ is chosen within those tested in the analysis, the change in the cost obtained is approximately 1%. To resume, the values of μ used are shown in Equation (4.4).

$$\mu = \begin{cases} 0.65, & s_{ijt_1} > 0 \\ 1.65, & s_{ijt_1} < 0 \end{cases} \quad (4.4)$$

where:

- s_{ijt_1} : is the land slope of the outer-branch pipe from m_i to $m_j \in \mathcal{A}_L$.
- μ : is the penalty for outer-branch pipes in the selection of the initial layout.

Summarizing, this criterion calculates the coefficient b_{ijt} as follows:

$$b_{ijt_2} = s_{ijt_2} * (-1) \quad (4.5)$$

$$b_{ijt_1} = s_{ijt_1} * (-1) * \mu \quad (4.6)$$

where:

- s_{ijt_2} : is the land slope of the inner-branch pipe from m_i to $m_j \in \mathcal{A}_L$.
- b_{ijt_1} : is the coefficient that depends on the land topography in the outer-branch pipe from m_i to $m_j \in \mathcal{A}_L$.
- b_{ijt_2} : is the coefficient that depends on the land topography in the inner-branch pipe from m_i to $m_j \in \mathcal{A}_L$.

Figure 4.2 shows an example of how the coefficient is calculated with Criterion 1 in the two types of pipes with positive and negative slopes. The gray dotted line represents an outer-branch pipe, where is calculated using Equation (4.6). On the contrary, the black continuous line represents an inner-branch pipe, where is calculated using Equation (4.5).

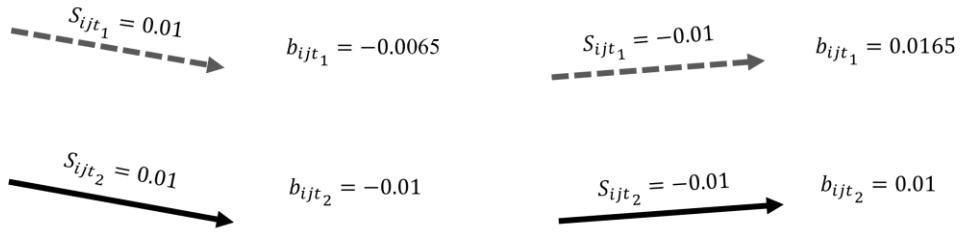

Figure 4.2. Example of the calculation of b_{ijt} with Criterion 1.

4.3.1.2 Criterion 2

This criterion works the same way as Criterion 1; the slope of each pipe is multiplied by -1 , and the outer-branch pipes are penalized as explained above. However, this criterion also seeks to involve the energy per unit weight or head available to transport the design flow rate in a pipe and, in this way, prioritize the pipes with greater head or energy differences. To achieve this, the slope of the pipe is also multiplied by its length, and in this way, making use of the available head as an input variable. To summarize, with this criterion, the coefficient b_{ijt} is calculated as follows:

$$b_{ijt_2} = s_{ijt_2} * (-1) * L_{ij} \quad (4.7)$$

$$b_{ijt_1} = s_{ijt_1} * (-1) * L_{ij} * \mu \quad (4.8)$$

Where L_{ij} : is the length of the pipe from m_i to $m_j \in \mathcal{M}$.

Figure 4.3 shows an example of how the coefficient is calculated with Criterion 2 in the two types of pipes with positive and negative slopes, where all pipes are 10 m in length. In outer-branch pipes the coefficient is calculated using Equation (4.8), while in inner-branch pipes Equation (4.7) is used.

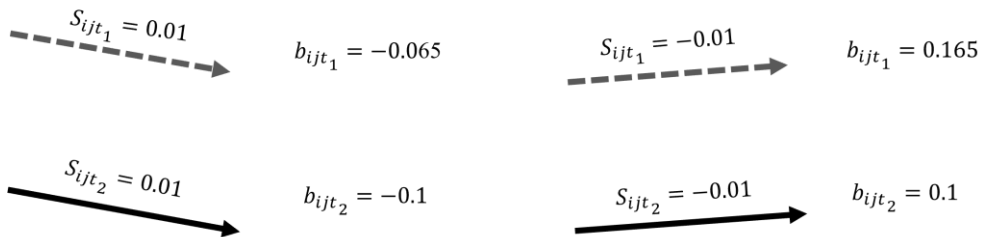

Figure 4.3. Example of the calculation of b_{ijt} with Criterion 2.

4.3.1.3 Criterion 3

With this criterion, the coefficient b_{ijt} is calculated as the Euclidean distance between the downstream manhole of the pipe, where the weight will be assigned, and the outfall. This criterion is proposed especially for flat topographies and seeks to minimize the length of the sewer network main series so that the final excavation depth decreases. In this criterion, the outer-branch pipes have the same weight as the inner-branch ones.

Figure 4.4 shows an example of how the coefficient b_{ijt} is calculated with Criterion 3.

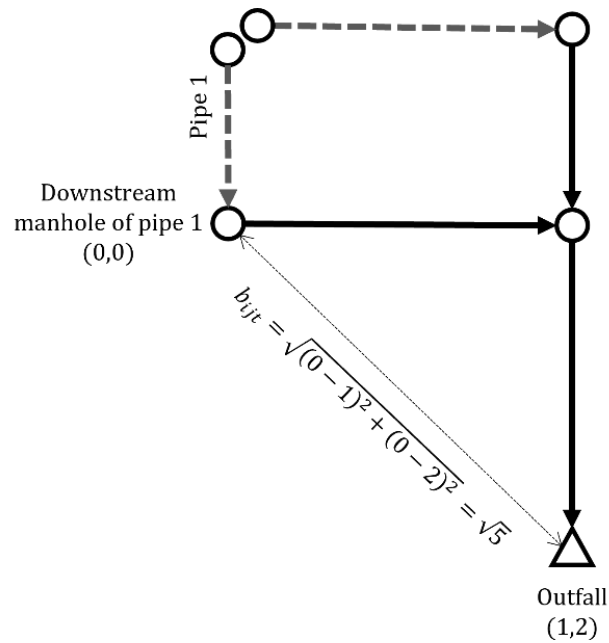

Figure 4.4. Example of the calculation of b_{ijt} with Criterion 3.

With the criteria explained above, three different layouts are obtained, one with each criterion. The one with the lowest cost is chosen as the initial layout. Then, the coefficients c_{ij} and a_{ij} are calculated to run the iteration with penalties in excavation. This process will be explained in the next section.

4.3.2 Iteration with Penalties in Excavation

Duque et al. [45] proposed to determine the value of c_{ij} and a_{ij} through a linear regression between the total cost of a pipe and its design flow rate. However, this methodology has two problems. First, the outer-branch pipes are included in the linear regression. This means that a big part of the data is concentrated in the intercept, where costs and design flow rates are low. Second, the length of the pipes is not considered in the linear regression because it relates the flow rate of a pipe to its total cost, not the cost per unit length. This means that costs with different magnitudes are related to the same flow rate in the regression.

For the first problem, this paper proposes not to include the outer-branch pipes in the linear regression since most of the time, this type of pipe uses the minimum diameter and excavation depth. This means that, generally, the cost per unit length is the same for every outer-branch pipe. For this reason, the cost of these pipes can be determined only by the coefficient b_{ijt} , which means that coefficients c_{ij} and a_{ij} are zero for these pipes.

With the initial layout, an initial hydraulic design is obtained, and in this way, it is possible to determine the average cost per unit length of the outer-branch pipes and the cost that will be assigned to the arcs of the layout selection model in the next iteration.

The above applies when the land slope is greater than or equal to the average installation slope of the outer-branch pipes in the previous iteration. If this is not the case, the excavation depth of the

downstream manhole may become greater, which causes an increase in the construction cost. This increment in cost is considered by a penalty in the coefficient b_{ijt} and is calculated as the cost of the extra excavated volume based on the diameter and slope of the pipes from the initial layout, the natural land slope, and the cost function from the hydraulic design model. Equation (4.9) defines the value of b_{ijt} for outerbranch pipes in the iteration with penalties in excavation.

$$b_{ijt_1} = \begin{cases} C_{t_1} * L_{ij}, & s_{ijt_1} \geq \overline{S_{t_1}} \\ C_{t_1} * L_{ij} + \gamma_{ij}, & s_{ijt_1} < \overline{S_{t_1}} \end{cases} \quad (4.9)$$

where:

- C_{t_1} : is the average cost per unit length of outer-branch pipes.
- $\overline{S_{t_1}}$: is the average installation slope of outer-branch pipes.
- γ_{ij} : is the penalty for increments in excavation cost in pipe from m_i to $m_j \in \mathcal{A}_L$.

For the second problem of the methodology proposed by Duque et al. [45], that is, not considering the effect of the pipes' length in the linear regression, this article proposes to perform the regression between the costs per unit length and the flow rate of each innerbranch pipe, where c_{ij} is equivalent to the slope of the linear equation and a_{ij} to the intercept.

Similar to outer-branch pipes, when the sewer network is located on steep terrain, there is a possibility that the methodology selects inner-branch pipes that are against the natural land slope to try to minimize the cost per flow unit. In this case, there is the problem again of obtaining pipes with greater excavation depths. This should be considered in the model the same way that with outer-branch pipes, this is, with the penalty for the increments in excavation costs.

Unlike outer-branch pipes, when the land slope is greater than the average installation slope, the depth of the upstream manhole may decrease. This implies a cost reduction associated with less excavation depth required, and it also should be considered in the coefficient b_{ijt} through a bonus that is calculated as the cost of the excavation depth multiplied by -1 .

In other words, for inner-branch pipes, the coefficient must include a bonus or penalty depending on the land slope and the average installation slope of these pipes. Equations (4.10) and (4.11) define the value of for this type of pipe as explained above.

$$b_{ijt_2} = \begin{cases} \omega_{ij}, & s_{ijt_2} \geq \overline{S_{t_2}} \\ \gamma_{ij}, & \text{d. l. c.} \end{cases} \quad (4.10)$$

$$\omega_{ij} = -\gamma_{ij} \quad (4.11)$$

where:

- $\overline{S_{t_2}}$: is the average installation slope of inner-branch pipes.
- ω_{ij} : is the bonus for reduction in excavation cost in pipe from m_i to $m_j \in \mathcal{A}_L$.

Unlike the methodology proposed by Duque et al. [45], the current methodology does not require several iterations because if the procedure performed in the iteration with penalties in excavation is repeated, similar coefficients b_{ijt} will be obtained. Therefore, computational time will be greater and similar designs will be obtained and not necessarily with lower costs. On the other hand, the iteration

with penalties in excavation does not always manage to reduce the costs of the sewer network design; sometimes the use of Criteria 1, 2 and 3 is sufficient to obtain the design with the lowest cost.

To resume, in the iteration scheme proposed in the present work, first, a sewer network design is obtained with each criterion; then, the initial layout is selected, which is the one with the lowest cost. Next, with the selected initial layout, the coefficients b_{ijt} , c_{ij} , and a_{ij} and are estimated and the iteration with penalties in excavation is performed. Finally, the design obtained with the initial layout and the one obtained with the penalties in the excavation are compared to select the design with the lowest cost as the solution. The above is summarized in Figure 4.5.

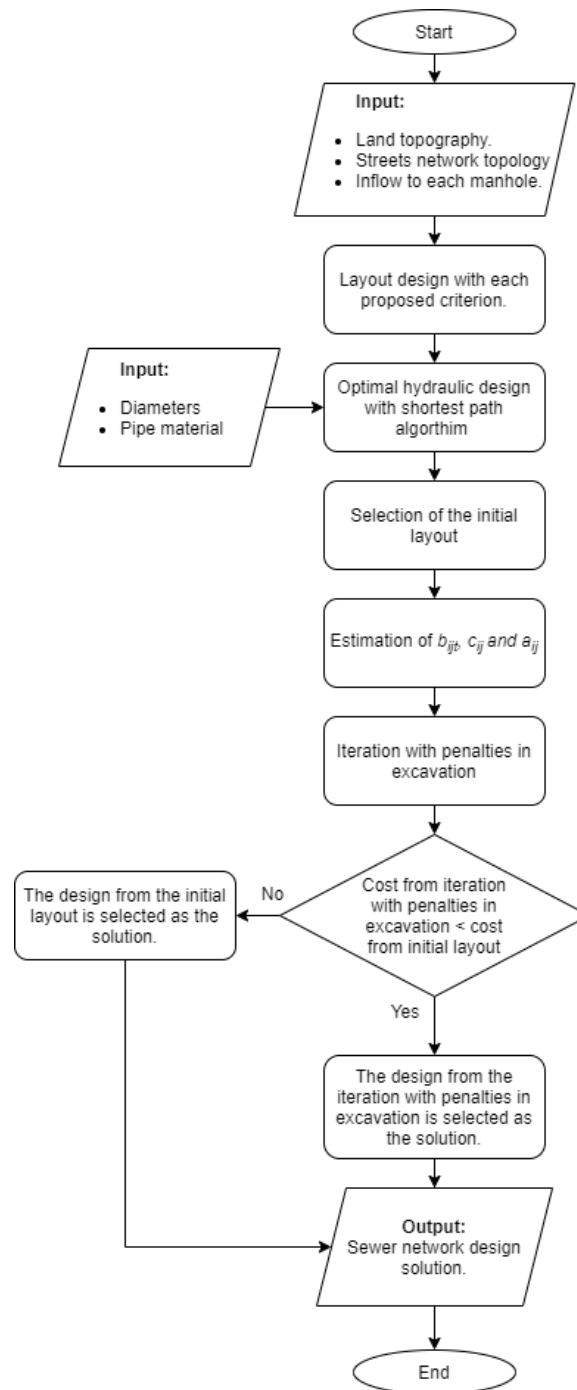

Figure 4.5. Methodology flow chart.

4.3.3 Case Studies

To compare the proposed approach with others found in the literature, the methodology was tested in three sewer networks. Each of them is composed of a number of manholes and pipes that are established by the street topology. Additionally, in each manhole, there is an inlet flow and the sum of these forms the total flow rate. This information is part of the input data of the model and is described below for each case study.

The first network was proposed by Li and Matthew [34]; it is composed of 57 manholes and 79 pipes, has a flat topography, and a total flow rate of 0.338 m³/s. The second sewer network was proposed by Moeini and Afshar [46]; it has 81 manholes, 144 pipes, a total flow rate of 0.593 m³/s, and its topography is completely flat since each manhole has the same elevation. The third sewer network is called Chicó and was proposed by Duque et al. [45]; it is part of a real sewer network located in Bogotá, Colombia. It has 109 manholes, 160 pipes, it is located in wavy topography terrain, and the total flow rate is 1.526 m³/s.

Table 4.1 presents the hydraulic constraints used in the three designs. For the velocity calculation, Manning's equation was used with a coefficient $n = 0.014$ (concrete). The set diameters, in meters, used are $D = \{0.2, 0.25, 0.3, 0.35, 0.38, 0.4, 0.45, 0.5, 0.53, 0.6, 0.7, 0.8, 0.9, 1.0, 1.05, 1.20, 1.35, 1.4, 1.5, 1.6, 1.8, 2, 2.2, 2.4\}$. The elevation change utilized was $\Delta Z = 0.1$ m, because in a 100-m-long pipe, this is the elevation that allows a 0.001 slope, which is the minimum buildable slope.

Table 4.1. Hydraulic constraints.

Constraint	Value	Condition
Minimum diameter	0.2 m	Always
	0.6	$d \leq 0.3$ m
	0.7	$0.35 \text{ m} \leq d \leq 0.45 \text{ m}$
	0.75	$0.5 \text{ m} \leq d \leq 0.9 \text{ m}$
Maximum filling ratio	0.8	$d \geq 1 \text{ m}$
	0.7 m/s	$d \leq 0.5 \text{ m}$ and Flow rate $> 0.015 \frac{\text{m}^3}{\text{s}}$
Minimum velocity	0.8 m/s	$d > 0.5 \text{ m}$ and Flow rate $> 0.015 \frac{\text{m}^3}{\text{s}}$
Maximum velocity	5 m/s	Always
Minimum gradient	0.003	Flow rate $< 0.015 \frac{\text{m}^3}{\text{s}}$
Minimum depth	1 m	Always

To compare the designs with previous designs, two cost functions were used. The first cost function was proposed by Li and Matthew [34], and it is presented in Equations (4.12) and (4.13)(4.13), where f_p and f_m are the construction cost in yuan for a pipe and a manhole, respectively.

$$f_p = \left\{ \begin{array}{ll} (4.27 + 93.59d^2 + 2.86dh + 2.39h^2)L & \text{if } d \leq 1 \text{ m and } h \leq 3 \text{ m} \\ (36.47 + 88.96d^2 + 8.70dh + 1.78h^2)L & \text{if } d \leq 1 \text{ m and } h > 3 \text{ m} \\ (20.50 + 149.27d^2 - 58.96dh + 17.75h^2)L & \text{if } d > 1 \text{ m and } h \leq 4 \text{ m} \\ (78.44 + 29.25d^2 + 31.80dh - 2.32h^2)L & \text{if } d > 1 \text{ m and } h > 4 \text{ m} \end{array} \right\} \quad (4.12)$$

$$f_m = \begin{cases} 136.67 + 166.19d^2 + 3.50dh + 16.22h^2 & \text{if } d \leq 1 \text{ m and } h \leq 3 \text{ m} \\ 132.91 + 790.94d^2 - 280.23dh + 34.97h^2 & \text{if } d \leq 1 \text{ m and } h > 3 \text{ m} \\ 209.74 + 57.53d^2 + 10.93dh + 19.88h^2 & \text{if } d > 1 \text{ m and } h \leq 4 \text{ m} \\ 210.66 - 113.04d^2 + 126.43dh - 0.60h^2 & \text{if } d > 1 \text{ m and } h > 4 \text{ m} \end{cases} \quad (4.13)$$

In Equations (4.12) and (4.13), d is the pipe diameter (m), h is the pipe average buried depth (m), and L is the pipe length (m).

The second cost function used was proposed by Maurer, Wolfram, and Anja [47]. This is presented in Equations (4.14)-(4.16).

$$C = (\alpha h + \beta) * L \quad (4.14)$$

$$\alpha = m_\alpha d + n_\alpha \quad (4.15)$$

$$\beta = m_\beta d + n_\beta \quad (4.16)$$

where C is the pipe construction cost in USD, L is the pipe length (m), α is a coefficient related to the excavation depth cost (USD*m⁻²), h is the buried depth (m), β is the pipe cost per unit length (USD*m⁻²), m_α , m_β , n_α , and n_β are constants and their values are presented in Table 4.2.

Table 4.2. Constants of the cost function proposed by Maurer et al. [47].

Constant	Value	Units
m_α	110	USD * m ⁻³
m_β	1200	USD * m ⁻²
n_α	127	USD * m ⁻²
n_β	-35	USD * m ⁻¹

4.4 Results

For each sewer network, Criteria 1, 2, and 3 were applied to obtain three different layouts. Then, for each network, the layout with the lowest cost was selected to estimate the value of coefficient b_{ijt} , the penalties, and bonuses. Lastly, the iteration with penalties in the excavation was run to try to obtain a lower cost than the cost obtained with the initial layout.

4.4.1 Benchmark Network Proposed by Li and Matthew

Table 4.3 presents the construction cost obtained with the cost function of Li and Matthew [34] and Maurer et al. [47].

Table 4.3. Construction cost for each criterion in the benchmark proposed by Li and Matthew [34].

Scenario	Construction cost × 10 ⁶ (CNY)	Construction cost × 10 ⁶ (USD)
	Function of Li and Matthew [34]	Function of Maurer et al. [47]
Criterion 1	1.36	20.06
Criterion 2	1.33	19.91
Criterion 3	1.42	19.58

For the cost function of Li and Matthew, the design obtained with Criterion 2 has the lowest cost. On the other hand, for the cost function of Maurer et al., the design with the lowest cost is the one obtained with Criterion 3. The layouts of these designs are selected as the initial layouts, and with these layouts, the iteration with penalties in the excavation was calculated. The construction cost obtained in the iteration with penalties in excavation with the cost function of Li and Matthew was CNY 1.12×10^6 and with the cost function of Maurer et al. was USD 17.01×10^6 . In both cases, the cost was reduced with the iteration with penalties in excavation.

Table 4.4 presents the construction cost achieved with the function of Li and Matthew with different methodologies proposed in the literature.

Table 4.4. Construction cost with different methods for the benchmark proposed by Li and Matthew [34].

Method	Researchers	Construction Cost $\times 10^6$ (CNY) Function of Li and Matthew [34]
MGA	Pan and Kao [32]	1.91
Adaptative GA	Haghighi and Bakhshipour [20]	1.84
Loop-by-loop cutting algorithm and GA-DDDP	Haghighi and Bakhshipour [35]	1.59
SDE-GOBL	Liu, Han, Wang, and Qiao [48]	1.53
Loop-by-loop cutting algorithm and TS	Haghighi and Bakhshipour [28]	1.43
Reliability-DDDP	Haghighi and Bakhshipour [1]	2.41
MILP	Safavi and Geranmehr [7]	1.57
ACOA-TGA-NLP	Moeini and Afshar [46]	1.39
MIP and DP	Duque et al. [45]	1.29
MIP and DP Extension	Present work	1.12

Figure 4.6 shows the designs for the lowest costs obtained with the cost function of Li and Matthew and with the cost function of Maurer et al. in the benchmark network proposed by Li and Matthew. The depth shown corresponds to the invert depth of manholes. This depth is with respect to the ground level on the manhole location. This notation does not mean that a pipe can go from a deeper to a shallower manhole because it is not taking into account the ground levels. This also applies to Figure 4.7 and Figure 4.8.

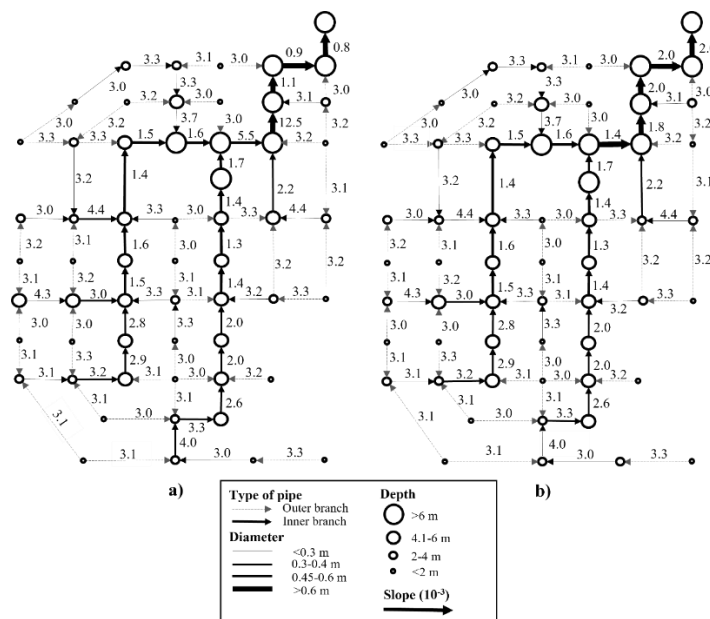

Figure 4.6. Scheme (not to scale) of the best design of the benchmark network proposed by Li and Matthew [34] with (a) their cost function and (b) the cost function of Maurer et al. [47].

4.4.2 Benchmark Network Proposed by Moeini and Afshar

To apply Criteria 1 and 2, it is necessary to have a pipe slope different from zero, which does not happen in the Moeini and Afshar network because originally, it was totally flat. For this reason, to apply Criteria 1 and 2, the manhole elevations were modified so that instead of a flat terrain, a small slope (0.001) was used for the layout selection. This was done only to obtain the layout, and then, in the hydraulic design, the original elevations were used, i.e., 1000 m for each manhole.

Table 4.5 presents the costs obtained with the different criteria and cost functions.

In this sewer network, designs with lower costs were obtained with Criterion 2 for both cost functions, and in the iteration with penalties in excavation, the cost achieved was CNY 38.45×10^4 with the cost function of Li and Matthew, and USD 845.08×10^4 with the cost function of Maurer et al. The iteration with penalties in excavation did not reduce the cost of the designs; therefore, the best designs are those obtained with Criterion 2. Table 4.6 presents the comparison of construction cost between different methods for this sewer network, and Figure 4.7 shows the designs with the lowest cost obtained with the cost function of Li and Matthew and with the cost function of Maurer et al.

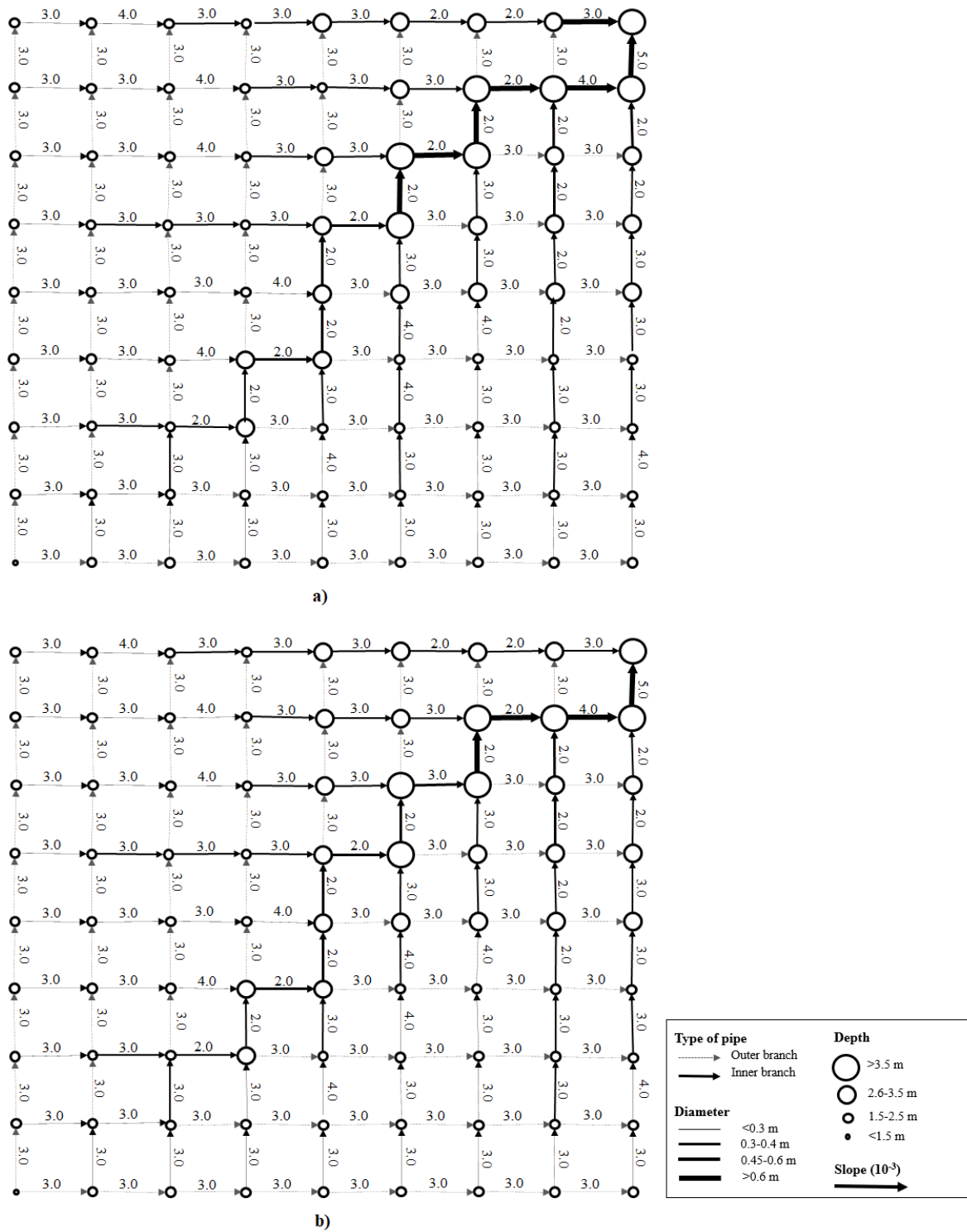

Figure 4.7. Scheme (not to scale) of the best design of the benchmark network proposed by Moeini and Afshar [46] with (a) the cost function of Li and Matthew [34] and (b) the cost function of Maurer et al. [47].

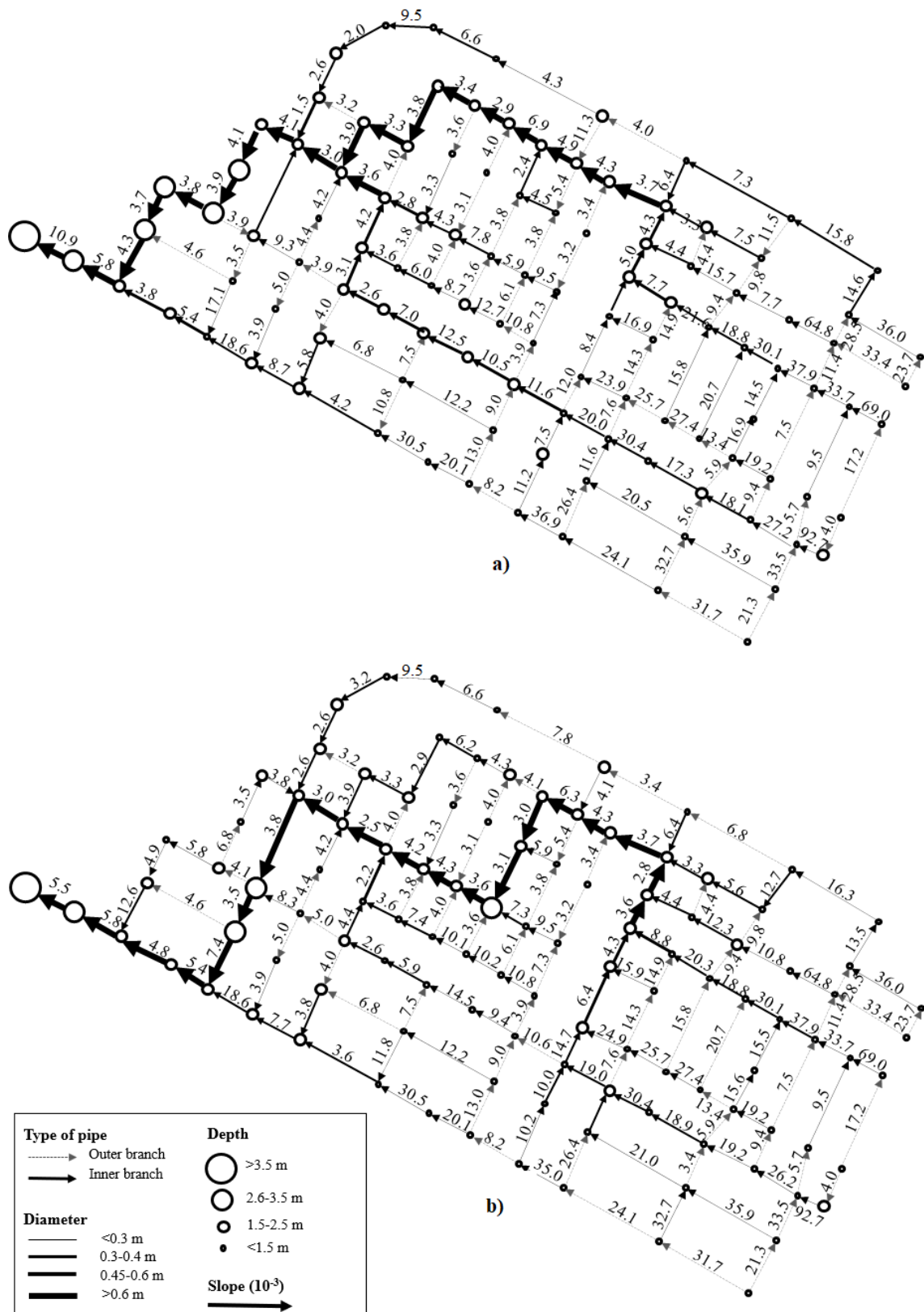

Figure 4.8. Scheme (not to scale) of the best design of the benchmark network proposed by Duque et al. [45] with (a) the cost function of Li and Matthew [34] and (b) the cost function of Maurer et al. [47].

Table 4.5. Construction cost for each criterion in the benchmark proposed by Moeini and Afshar [46].

Scenario	Construction cost $\times 10^4$ (CNY) Function of Li and Matthew [34]	Construction cost $\times 10^4$ (USD) Function of Maurer et al. [47]
Criterion 1	36.86	817.83
Criterion 2	35.99	813.46
Criterion 3	45.55	862.07

Table 4.6. Construction cost with different methods for the benchmark proposed by Moeini and Afshar [46].

Method	Researchers	Construction Cost $\times 10^4$ (CNY) Function of Li and Matthew [34]
ACOA-TGA-NLP	Moeini and Afshar [46]	64.08
MIP and DP	Duque et al. [45]	36.95
MIP and DP Extension	Present work	35.99

4.4.3 Benchmark Network Proposed by Duque et al.: Chicó

In the sewer network Chicó, the lowest cost was achieved with Criterion 2 using the Li and Matthew function and with Criterion 1 using the Maurer et al. function. Table 4.7 presents the cost obtained with each criterion.

Table 4.7. Construction cost for each criterion in the benchmark proposed by Duque et al. [45].

Scenario	Construction cost $\times 10^4$ (CNY) Function of Li and Matthew [34]	Construction cost $\times 10^4$ (USD) Function of Maurer et al. [47]
Criterion 1	38.22	843.38
Criterion 2	38.12	856.89
Criterion 3	60.01	1093.93

After running the iteration with penalties in excavation, the cost obtained was CNY 39.04×10^4 with the cost function of Li and Matthew and USD 886.87×10^4 with the cost function of Maurer et al.; this means the iteration with penalties in excavation did not achieve a lower cost. Consequently, the best designs are the ones found in the initial layout stage. Table 4.8 compares this cost with the cost achieved by Duque et al. [1].

Table 4.8. Construction cost with different methods for the benchmark proposed by Duque et al. [45].

Method	Researchers	Construction Cost $\times 10^4$ (CNY) Function of Li and Matthew [34]	Maximum Excavation Depth (m)	Outfall Diameter (m)
MIP and DP	Duque et al. [45]	69.91	15.9	1.05
MIP and DP Extension	Present work	38.12	4.5	0.9

Figure 4.8 shows the designs with the lowest cost obtained with the cost function of Li and Matthew and with the cost function of Maurer et al.

The input data and the detailed hydraulic design of each sewer network tested can be found in the Supplementary Material.

4.4.4 Computational Effort

In order to compare the computational effort in the methodology proposed by Duque et al. [45] and the current methodology, Table 4.9 shows the iterations and computational time used with each approach in each case study with the cost function of Li and Matthew and an elevation change of $\Delta Z = 0.1$ m. In MIP and DP Extension, three of the four iterations correspond to the three different designs obtained with each criterion describing land topography, and the other iteration corresponds to the one with penalties in excavation.

Table 4.9. Computational effort in MIP and DP, and MIP and DP Extension.

Benchmark network	MIP and DP (Duque et al. [1])		MIP and DP Extension (Present work)	
	Iterations (-)	Time (min)	Iterations (-)	Time (min)
Li and Matthew [34]	10	45	4	5
Moeini and Afshar [46]	30	115	4	12
Duque et al. [45]: Chicó	25	113	4	7

4.5 Discussion

In all three case studies, the proposed methodology achieved designs with lower costs than previously reported in the literature. This demonstrates the importance of incorporating the land topography criterion into the layout selection model, especially in very-flat or non-uniform terrain, where it is difficult for an engineer to select the optimal layout or one close to it.

The most significant cost reduction was obtained in the sewer network Chicó. This is mainly due to the decrease in the maximum excavation depth. This shows that considering the land topography achieves very satisfactory results in sewer networks located on wavy or non-flat topography. On the other hand, in the sewer network of Moeini and Afshar, it was more difficult to apply the methodology due to the change in elevations that had to be made since it is a hypothetical sewer network without slope. Although this network also managed to improve the costs reported in the literature, the cost reduction was not as significant.

Comparing the methodology proposed by Duque et al. [45] with the proposal in this paper, it can be seen that the construction cost of the sewer networks tested was reduced. In addition, this was achieved with a much shorter computational effort, since the methodology of Duque et al. [45] used between 10 and 30 iterations per network, while in this methodology, only four iterations per network are necessary, three for the selection of the initial layout and another one for the iteration with penalties in excavation. As for computational time, this was reduced by approximately 88% in the Li and Matthew, and Moeini and Afshar benchmark networks, and by about 94% in the Chicó network.

Achieving the design of a sewer network that complies with hydraulic restrictions and has a lower construction cost is important, especially for populations that have a limited budget and that often opt for cheaper alternatives that do not meet all the necessary restrictions for proper hydraulic operation. In addition, having cheaper sewer networks designs favors achieving equitable and adequate access

to sanitation services, which is one of the targets related to Sustainable Development Goal 6 (Clean Water and Sanitation) [49].

4.6 Conclusions

This article proposes an objective function for the layout selection problem of a sewer network system that considers all the variables known in this problem, such as: land topography, streets network topology, and inflows to each manhole.

To apply the proposed function, two stages are needed. The first one consists of the selection of an initial layout and its hydraulic design. This initial layout is determined through criteria that seek to follow the topography of the area. The hydraulic design of the initial layout is carried out according to the methodology proposed by Duque et al. [45], which guarantees global optimality.

The second stage consists of penalizing the excavation of the pipes and determining the coefficients of the proposed objective function so that an accurate approximation of the construction cost of each arc of the layout selection problem can be made. This is in order to try to achieve lower costs than in the first stage.

The methodology was tested in three benchmarks using two cost functions proposed by Li and Matthew [34] and Maurer et al. [47]. The cost obtained with the function of Li and Matthew was used to compare the designs obtained with the designs of other methodologies of the literature. With the results obtained, the following conclusions were made:

- In the three case studies tested, the present methodology achieved the lowest construction cost reported in the literature. The cost reduction was more significant in the network with wavy topography, i.e., Chicó. While in the other networks, which are flat, the cost reduction was not so big, especially in the Moini and Afshar network, which is completely flat.
- The cost reduction was achieved in fewer iterations and in significantly less computational time when compared to the methodology of Duque et al. [1]. This shows that when selecting an optimal layout or one close to it, it is only required to perform the shortest path algorithm once to obtain a cost-effective sewer network design.
- Land topography turned out to be an important input in the layout selection model since whether the land topography is flat or not, a layout that follows the land slope and maximizes the number of inner-branch pipes allows a cost-effective layout to be obtained.

In future research, the current methodology could be easily extended to include drop manholes in hilly terrains and pumping stations in very flat terrains. Moreover, other cost functions could be used in the layout selection problem, such as nonlinear equations, to represent more accurately the construction costs of each arc. Further, in the future, the resilience of the sewer network should be considered in a multi-objective optimization scheme, as well as consider the possibility of dividing the layout to increase the resilience of the system.

Supplementary Materials: The following are available online at www.mdpi.com/2073-4441/13/18/2491/s1, Table S1: Input data of the benchmark proposed by Li and Matthew [34], Table S2: Hydraulic design for the benchmark proposed by Li and Matthew [34] with cost function of Li and Matthew [34], Table S3: Hydraulic design for the benchmark proposed by Li and Matthew [34] with cost function of Maurer et al. [47], Table S4: Input data benchmark proposed by Moeini and Afshar [46], Table S5: Hydraulic design for the benchmark proposed by Moeini and Afshar [46] with cost function of Li and Matthew [34], Table S6: Hydraulic design for the

benchmark proposed by Moeini and Afshar [46] with cost function of Maurer et al. [47], Table S7: Input data benchmark proposed by Duque et al.: Chicó [45], Table S8: Hydraulic design for the benchmark proposed by Duque et al.: Chicó [45] with cost function of Li and Matthew [34], Table S9: Hydraulic design for the benchmark proposed by Duque et al.: Chicó [45] with cost function of Maurer et al. [47].

Author Contributions: Conceptualization, J.S. and J.Z.; methodology, J.S. and J.H.; software, J.Z.; validation, J.S., J.H., and P.L.I.-R.; formal analysis, J.S. and J.H.; investigation, J.S., J.Z., J.H., and P.L.I.-R.; writing—original draft preparation, J.Z. and J.H.; writing—review and editing, J.S., J.H., and P.L.I.-R. All authors have read and agreed to the published version of the manuscript.

Funding: This research received no external funding.

Conflicts of Interest: The authors declare no conflict of interest.

Nomenclature

From methodology proposed by Duque et al. [45]:

- \mathcal{M} set of nodes representing manholes.
- \mathcal{E} set of undirected edges representing links between two nodes $m_i \in \mathcal{M}; m_j \in \mathcal{M}$.
- \mathcal{A}_L set of directed links between two manholes, m_i and m_j , so that $(m_i, m_j) \in \mathcal{E}$.
- T set of possible types of pipes, containing outer-branch pipes (t_1) and inner-branch pipes (t_2).
- x_{ijt} binary decision variable that represents the flow direction and connection type in the network layout, for all $(m_i, m_j) \in \mathcal{A}_L$ and $t \in T$.
- q_{ijt} continuous decision variable that represents the flow through arc m_i, m_j of type t , for all $(m_i, m_j) \in \mathcal{A}_L$ and $t \in T$.
- a_{ij} fixed cost estimate for selecting the flow direction m_i to m_j .
- c_{ij} estimation of cost per flow unit that traverses from m_i to m_j .

From present methodology:

- b_{ijt} coefficient that depends on the land topography in the pipe from m_i to $m_j \in \mathcal{A}_L$ of type $t \in T$.
- s_{ijt} land slope in the pipe from m_i to $m_j \in \mathcal{A}_L$ of type $t \in T$.
- \overline{S}_{t_1} average installation slope of outer-branch pipes.
- \overline{S}_{t_2} average installation slope of inner-branch pipes.
- L_{ij} length of the pipe from m_i to $m_j \in \mathcal{M}$.
- C_{t_1} average cost per unit length of outer-branch pipes.
- μ penalty for outer-branch pipes in the selection of the initial layout.
- γ_{ij} penalty for increments in excavation cost in pipe from m_i to $m_j \in \mathcal{A}_L$.
- ω_{ij} bonus for reduction in excavation cost in pipe from m_i to $m_j \in \mathcal{A}_L$.

5. Optimal Sewer Network Design for Cities in Hilly Regions

Preamble

Traditionally, the Sewer Network Design (SND) includes the selection of the layout or tree, on the one hand, and the hydraulic design, on the other. With the layout, the tree is found including the inner-branch pipes, the outer-branch pipes, and the flow rates of each section. With the optimal hydraulic design, the diameters and slopes, the beginning and end invert elevations, and the filling ratio are calculated for each section, all of this complying with the hydraulic restrictions (maximum and minimum velocities, minimum shear stress, etc.) and constructive restrictions (available diameters, materials and roughness, maximum and minimum excavation depths, etc.). The design is solved as an optimization problem using a graph in which the pipes represent the arcs and the manholes the nodes. However, the design does not consider structures other than manholes, which is not true in some sewer networks. This third paper, which forms Chapter 5, describes how a new structure typical of sewer systems in steep terrain (hilly regions), the drop manhole, was included in the optimized design methodology. Each drop manhole was represented as the set of a new arc and two new nodes in the hydraulic design (HD) graph described in the previous chapters. The two nodes correspond to the invert elevation of the inlet and outlet pipe of the manhole, respectively, and the length of the arc corresponds to the drop height. It is an arc with different characteristics than the arcs representing the pipes, which include a length, slope, and diameter; the new arc only includes a drop length. Within the shortest path algorithm, a new term was included in the cost equation that describes the cost of a drop manhole in terms of its depth. Additionally, a new hydraulic and constructive constraint, the minimum drop height, was included. The methodology was able to obtain a minimum cost design by giving the diameters and slopes of each section, as well as the location of drop manhole with their heights. It is important to clarify that the methodology considers every manhole as a possible drop manhole, but only chooses those that lead to the optimum design.

The reference of this paper is:

Saldarriaga, J.; Herrán, J.; Iglesias-Rey, P.L. Optimal Sewer Network Design for Cities in Hilly Regions. *Urban Water Journal* **2023**, 1–11, doi: <https://doi.org/10.1080/1573062x.2023.2229303>.

5.1 Introduction

Drop manholes are complementary structures in a sewer network that are important for energy dissipation and velocity reduction [1]. These are relevant in hilly regions where steep slopes induce velocities that exceed the maximum values allowed. In this type of topography, if no structure is used to keep the velocity below the maximum allowable, high velocities can affect other structures of the sewer network, such as manholes, as well as cause abrasion problems on the inner surfaces of pipes.

Several studies have used laboratory experiments to investigate the hydraulic properties of drop

manholes. Empirical equations for the design of drop manholes have been proposed based on the results of these experiments ([2]; [3]; [4]; [5]). Other works have emphasized a particular hydraulic feature, such as flow regimes in drop manholes [6], choking phenomena [7], air entrainment mechanisms [8], and energy dissipation [1]. However, no research has studied the features of drop manholes in sewer systems, such as their optimal location or optimal drop height.

As for the sewer network design, it presents two problems: the layout selection, which determines the type, direction, and flow rate of pipes; and the hydraulic design, which defines the diameter and invert elevation of each pipe. In the existing literature, numerous methodologies have been proposed with different approaches to solving these problems.

Many of the proposed approaches tried to sequentially solve the two problems of optimal sewer network design. For example, [9] presented a model formulated as a mixed integer nonlinear programming (NLP) problem for the layout selection and used the simulated annealing method for the hydraulic design. Moeini and Afshar ([10], [11]) employed the Tree Growing Algorithm to generate layouts and the Arc Colony Optimization Algorithm combined with NLP for the design of pipe diameters and slopes. Navi and Mathur [12] used the generation of spanning trees to create a predefined number of layouts, and the modified particle swarm optimization algorithm to find the optimal size of the layouts. Alfaisal and Mays [13] modelled the optimization problem using integer NLP and solved it with the General Algebraic Modelling System. Li and Matthew [14] used the searching direction method for layout selection and discrete differential dynamic programming for the hydraulic design. Haghighi and Bakhshipour [15] applied the Loop-by-Loop Cutting Algorithm to select the layout, followed by tabu search to optimize the cost function of the hydraulic design. Duque et al. [16] used mixed integer programming (MIP) to find the layout of the network and a shortest path algorithm to find the optimal hydraulic design for the given layout. This methodology has been extended by Saldarriaga et al. [17], who included topographic criteria in the layout selection, which proved to be effective in finding layouts that resulted in lower-cost hydraulic designs.

Even though drop manholes and optimized sewer network design have been studied in numerous works, there are few methods in the literature that integrate both concepts; that is, that provide an approach to optimized sewer network design that includes drop manholes. These methods are relevant because the cost of the drop manholes can represent a significant percentage of the total cost of the network in a hilly region. As a result, determining the optimal number of drop manholes, their location, and drop height is essential for achieving the lowest-cost design.

Due to the above, the current work proposes a method for determining the optimal design of sewer networks, including drop manholes. The sewer network design methodology is based on the work of Duque et al. [16] and Saldarriaga et al. [17], who proposed an approach that guarantees optimality in the designs. However, the main contribution of the present work is to extend this methodology so it can be applied in hilly regions, where drop manholes are required to comply with the hydraulic constraints that ensure no damages in the infrastructure due to excessive flow velocity or energy. The proposed method also guarantees that all the decisions related to drop manholes, such as location or drop height, led to the minimum-cost design. The methodology was tested in a variety of pipe configurations as well as in a real sewer network in Bogotá, Colombia, which had previously been used as a case study in previous works in the literature.

5.2 General methodology for sewer networks design

As mentioned before, the optimal sewer network design is composed of two subproblems: the layout selection and the hydraulic design. To address the layout selection, the present work adopts the methodology proposed by Saldarriaga et al. [17]. This method employs a MIP model to choose the network layout. The MIP model has constraints that guarantee a feasible layout and an objective function that minimizes excavation costs by aligning the pipes in the direction of the terrain's slope.

For the hydraulic design, the methodology proposed by Duque et al. [16] is used. The extension to include drop manholes in the sewer network design is implemented as an extension of this methodology, as will be further explained later in the article.

In the methodology of Duque et al. [16], the input data required to solve the hydraulic design is a selected layout, a list of commercially available diameters, the roughness of the pipe material, the kinematic viscosity of water used in the Darcy-Weisbach equation to calculate the friction factor, and a cost function that depends on the diameter and excavation depth of the pipes. With this information, the hydraulic design is solved with a shortest path algorithm that evaluates all the feasible combinations of diameters and excavation depths of pipes to find the optimal combination for the network, which corresponds to the minimum cost design.

In the shortest path algorithm, the hydraulic design problem is modelled as a directed graph $\mathcal{G}_D = (\mathcal{N}_D, \mathcal{A}_D)$. Here, $\mathcal{N}_D = \{v_1^1, \dots, v_i^k, v_D^T\}$ is the set of nodes, where the node v_i^k is the i th design node of the manhole v^k . Each manhole has as many design nodes as combinations of available pipe diameters and excavation depths. This means that each node v_i^k has two attributes: $\delta(v_i^k)$, the possible diameter for an upstream pipe; and $Z(v_i^k)$, the potential excavation depth of the manhole. The possible diameters are determined by the list of commercially available diameters, while the potential excavation depth is determined by the excavation limits and a discretization parameter ΔZ . The feasible excavation depths start at the minimum excavation limit and decrease with the discretization parameter ΔZ until the maximum excavation limit, i.e., $Z_{min}, Z_{min} + \Delta Z, Z_{min} + 2\Delta Z, \dots, Z_{max}$.

The other component of the hydraulic design graph is the set of arcs \mathcal{A}_D , in which one arc $(v_i^k, v_j^{k'})$ represents a pipe from manhole v^k to manhole $v^{k'}$. Each arc has an associated cost $C(v_i^k, v_j^{k'})$ that depends on the diameter and excavation depth of the downstream design node. An arc $(v_i^k, v_j^{k'})$ can only be part of the graph \mathcal{G}_D if it satisfies all hydraulic and commercial constraints.

Figure 5.1 shows an example of a pipe between two manholes, represented with their respective design nodes and arcs. In the manholes, each circle represents a design node. The different sizes of the circles represent the possible diameters, which in the figure are only four, but as many diameters as desired can be included in the methodology. Also, the horizontal rectangles where the design nodes are located represent the possible excavation depths. The dark circles are the design nodes selected by the algorithm; these nodes contain information about the optimal excavation depth of the manholes v^k and $v^{k'}$, and the optimal diameter of their upstream pipe. As for the arcs, the light grey arrows between the manholes represent the feasible arcs. The black arrow is the arc selected by the

shortest path algorithm, which joins the selected design nodes.

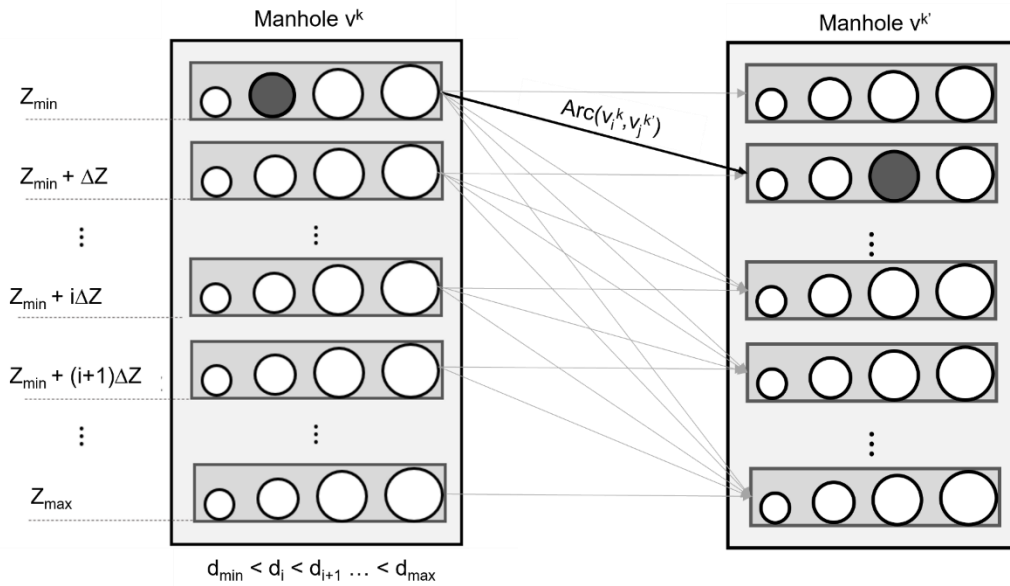

Figure 5.1. Representation in the hydraulic design model of a pipe between two manholes with its respective design nodes and arcs.

5.3 Methodology adapted for hilly regions

5.3.1 Addition of drop manholes in the developed optimization scheme

Drop manholes connect an upstream pipe to a downstream pipe, that is at a lower excavation depth. This difference in elevation is known as drop height and allows energy dissipation in the flow. The above is depicted in Figure 5.2a, where $\delta(v_i^k)$ and $\delta(v_j^k)$ represent the upstream and downstream diameters, respectively.

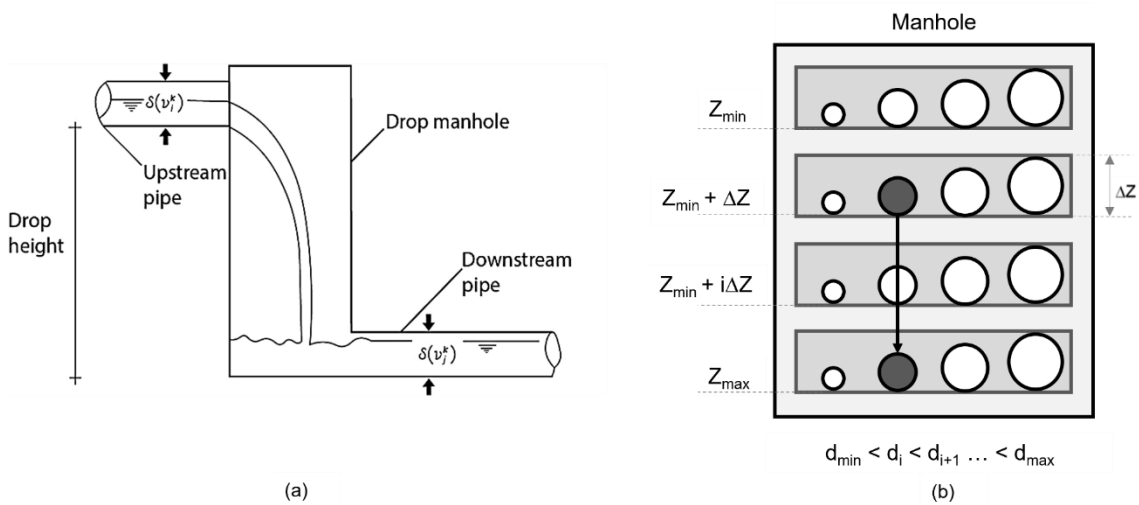

Figure 5.2. (a) Scheme of a drop manhole. (b) Representation of a drop manhole in the graph model.

To consider drop manholes in the sewer network design, it is necessary to represent these structures in the model that solves the hydraulic design. As previously stated, the hydraulic design is represented as a graph, with nodes representing possible combinations of diameters and depths and arcs representing feasible joints between these combinations. The methodology proposes modelling drop manholes as a new type of arc in this graph. In contrast to the original arcs, the new arcs have a vertical direction and connect two nodes of the same manhole. To represent the drop height, the downstream node must have a deeper excavation depth. Figure 5.2b presents an example of an arc that represents a drop manhole in the methodology. Recall that the circles represent the nodes, and the arrows the arcs.

To distinguish the original arcs of the hydraulic design graph from the new arcs that represent drop manholes, the former will be referred to as arcs type 1, while the latter will be referred to as arcs type 2. Since arcs type 1 and type 2 represent different elements of a sewer network, each type of arc is associated with a different cost function. The cost function of arcs type 1 represents the cost of pipes and depends on the average excavation depth and diameter of the pipe. On the other hand, the cost function of arcs type 2 represents the cost of drop manholes, which generally depends on their excavation depth, that is associated with the drop height. In the present work, some equations are proposed to model the costs of pipes and drop manholes, but the methodology could be used with any other cost function.

Now, there are different possible drop heights for a drop manhole. Therefore, one drop manhole is represented with several feasible arcs type 2, each one of them representing a different drop height. From these feasible arcs, the methodology will select the one that complies with all the hydraulic constraints, and together with the other selected arcs, leads to the optimal design of the sewer network.

So far, it has been explained how the drop manholes are included in the directed graph of the hydraulic design problem and what characteristics their modelling has. Now, to find the optimal solution for the hydraulic design, a shortest path algorithm is used.

This algorithm is used for determining the path of arcs that represent the combination of pipes and drop manholes with the lowest cost. That is, by including the drop manholes in the directed graph, the shortest path algorithm has the option of adding a drop manhole to any of the manholes in the network. It should be noted that this will only happen if adding the drop manhole lowers the overall cost of the design.

The shortest path algorithm used in this study is the Bellman-Ford algorithm. This algorithm works by evaluating nodes from downstream manholes to upstream manholes, beginning at a dummy node located downstream of the outfall. At each node, the cumulative cost is calculated by evaluating all outgoing arcs, including arcs type 2. The algorithm starts by assigning a large or infinite value to the cumulative cost at the dummy node, after that, the nodes of the upstream manhole are evaluated. If the evaluated cost ($V_i + c_i$) is lower than the current cumulative cost (V), then the cumulative cost is updated with the lower value. The process is repeated for all the nodes in the manhole, and then, for the remaining upstream manholes. The process described above is illustrated in Figure 5.3, where it is shown an example of the calculation of the cumulative cost in the node that is highlighted in gray.

Note that in the example of the figure, two arcs are being evaluated, an arc type 1 and an arc type 2. More details about the implementation of the Bellman-Ford algorithm applied to sewer systems design could be found in Duque et al. [18] for series of pipes and Duque et al. [16] for sewer networks.

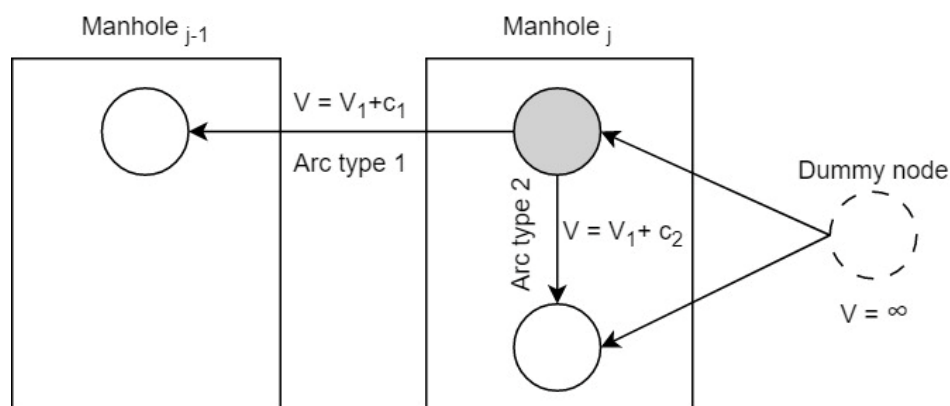

Figure 5.3. Example of cumulative cost calculation at a node during the shortest path algorithm.

As for the computational resources, with the addition of arcs type 2 to the methodology, the solution space increases, which means that the shortest path algorithm must evaluate a larger number of arcs to select the arc with the lowest cost. This means that the proposed methodology requires more computational time than the methodology without drop manholes. For example, in the comparison of sewer network design methodologies performed in the present study (presented later in the paper), the methodology with drop manholes required around 30% more execution time than the methodology of Saldarriaga et al. [17].

5.3.2 Development of a drop manhole cost function

In the developed methodology, any cost function can be implemented. However, two cost functions were used in the present work, one proposed by Li and Matthew [14] and the other proposed by Maurer et al. [19].

Li and Matthew's [14] cost function is composed of two groups of equations: one group describes the cost of pipes and another group describes the cost of manholes. For the development of this work, the group of equations that describes the cost of manholes was also used to model the cost of drop manholes. On the other hand, the function of Maurer et al. [19] only describes the cost of pipes. Therefore, it was necessary to develop a cost function that describes the cost of drop manholes in the same units as the function of Maurer et al. [19], i.e., US dollars (USD).

According to Li and Matthew's [14] cost function, the cost function of drop manholes has the structure shown in Equation (5.1)(5.1), where C_{dmh} is the drop manhole cost, h is the excavation depth in meters, d is the exiting diameter of the drop manhole in meters, and c_1 to c_6 are constants that change depending on the cost units.

$$C_{dmh} = c_1 - c_2h + c_3d - c_4hd + c_5h^2 + c_6d^2 \quad (5.1)$$

To find the values of the constants c_1 to c_6 that provide the cost of the drop manholes in USD, the following procedure was done. First, the proposed case studies (described later) were designed with the cost function of Li and Matthew [14]. In this way, the cost of each pipe and each drop manhole was obtained. Subsequently, the percentage that represents the cost of each drop manhole with respect to the average cost of a pipe was calculated. After that, the average cost of the pipes was calculated with the cost function of Maurer et al. [19]. Then, the cost of each drop manhole in USD was determined by multiplying the percentage mentioned above by the average cost of a pipe obtained with the cost function of Maurer et al. [19]. Finally, with the value of the exiting diameter, the excavation depth, and the cost in USD of each drop manhole, a multiple regression was made. The result achieved was Equation (5.2).

$$C_{dmh} = 4354.38 - 776.76h + 5404.52d - 6370.59hd + 870.05h^2 + 12820.76d^2 \quad (5.2)$$

The multiple regression achieved an R^2 equal to 0.99. The adjustment of the regression can be observed in the supplementary material (Appendix a).

5.4 Case studies

The methodology was tested in eight configurations of series of pipes and a sewer network. The pipe series varied the number of pipes (10 and 20), the slope (5% and 10%), and the material (one that produces hydraulically smooth turbulent flow and another that produces hydraulically rough turbulent flow, in both cases for all diameters and flow rates). The length of the pipes remained constant at 50 meters, and the inflow to each manhole was $0.1 \text{ m}^3/\text{s}$ in all pipes of all configurations.

Regarding the sewer network, the methodology was tested in the *Chicó* network, which is a real sewer network located in Bogotá that has 109 manholes and 160 pipes. In order to have a steep topography, the elevation of the terrain was modified to have a slope of 5% and 10%. Smooth and rough materials were used in this network, but a very rough material was also used to study the effects of roughness on construction costs. The inflows and coordinates of each manhole in the network can be found in the supplementary material.

All the configurations of series of pipes and the sewer network were tested using the cost function proposed by Li and Matthew [14] and the cost function proposed by Maurer et al. (2010), along with the proposed cost function for drop manholes developed in this work. Equations (5.3) and (5.4) present the cost function of Li and Matthew [14], where f_p is the cost of a pipe (Yuan), f_m is the cost of a manhole or drop manhole (Yuan), h is the pipe average buried depth (m), L is the pipe length (m), and d is the pipe diameter (m) of the downstream pipe diameter in the case of manholes and drop manholes.

$$f_p = \left\{ \begin{array}{ll} (4.27 + 93.59d^2 + 2.86dh + 2.39h^2)L & \text{if } d \leq 1 \text{ m and } h \leq 3 \text{ m} \\ (36.47 + 88.96d^2 + 8.70dh + 1.78h^2)L & \text{if } d \leq 1 \text{ m and } h > 3 \text{ m} \\ (20.50 + 149.27d^2 - 58.96dh + 17.75h^2)L & \text{if } d > 1 \text{ m and } h \leq 4 \text{ m} \\ (78.44 + 29.25d^2 + 31.80dh - 2.32h^2)L & \text{if } d > 1 \text{ m and } h > 4 \text{ m} \end{array} \right\} \quad (5.3)$$

$$f_m = \begin{cases} 136.67 + 166.19d^2 + 3.50dh + 16.22h^2 & \text{if } d \leq 1 \text{ m and } h \leq 3 \text{ m} \\ 132.91 + 790.94d^2 - 280.23dh + 34.97h^2 & \text{if } d \leq 1 \text{ m and } h > 3 \text{ m} \\ 209.74 + 57.53d^2 + 10.93dh + 19.88h^2 & \text{if } d > 1 \text{ m and } h \leq 4 \text{ m} \\ 210.66 - 113.04d^2 + 126.43dh - 0.60h^2 & \text{if } d > 1 \text{ m and } h > 4 \text{ m} \end{cases} \quad (5.4)$$

Equation (5.5) presents the cost function of Maurer et al. [19], where C is the cost of a pipe (USD), L is the pipe length (m), h is the buried depth (m), and d is the pipe diameter (m). This equation is used in conjunction with the equation proposed in this work to calculate the cost of drop manholes in USD. (See Equation (5.2)).

$$C = ((110d + 127)h + (1200d - 35))L \quad (5.5)$$

The hydraulic constraints used correspond to the constraints proposed by Li and Matthew [14], which are presented in Table 5.1. For smooth pipes, it is assumed that the Kármán-Prandtl equation applies, where the hydraulic roughness is null (Carvajal et al. [20]), while for rough pipes, the Colebrook-White equation applies with a roughness of 0.3 mm and 3 mm for the rough and very rough materials, respectively. The list of commercial diameters used is {0.2, 0.25, 0.3, 0.35, 0.38, 0.4, 0.45, 0.5, 0.53, 0.6, 0.7, 0.8, 0.9, 1.0, 1.05, 1.20, 1.35, 1.4, 1.5, 1.6, 1.8, 2.0, 2.2, 2.4} in meters.

Table 5.1. Hydraulic constraints.

Constraint	Value	Condition
Minimum diameter	0.2 m	Always
	0.6	$d \leq 0.3 \text{ m}$
Maximum filling ratio	0.7	$0.35 \text{ m} \leq d \leq 0.45 \text{ m}$
	0.75	$0.5 \text{ m} \leq d \leq 0.9 \text{ m}$
	0.8	$d \geq 1 \text{ m}$
Minimum velocity	0.7 m s^{-1}	$d \leq 0.5 \text{ m}$ and flow rate $> 0.015 \text{ m}^3 \text{ s}^{-1}$
	0.8 m s^{-1}	$d > 0.5 \text{ m}$ and flow rate $> 0.015 \text{ m}^3 \text{ s}^{-1}$
Maximum velocity	5 m s^{-1}	Always
Minimum gradient	0.003	Flow rate $< 0.015 \text{ m}^3 \text{ s}^{-1}$
Minimum depth	1 m	Always

5.5 Results and discussion

5.5.1 Results in the series of pipes

The proposed methodology was used to design the eight pipe series configurations. The results of the designs obtained using the two cost functions are presented in Table 5.2.

Table 5.2. Results in the series of pipes.

Results using the cost function of Li and Matthew (1990)								
N° of pipes (-)	Slope (%)	Material (-)	Total cost (CNY) x10 ⁴	DM cost (CNY) x10 ⁴	DM (%)	N° DM (-)	MDH (m)	Max V (m s ⁻¹)
10	5	S	1.89	0.20	10.42	8	1.7	4.98
10	5	R	1.87	0.14	7.63	5	1.1	4.99
10	10	S	3.43	0.52	15.05	9	4.2	5.00
10	10	R	2.44	0.33	13.70	8	3.6	4.99
20	5	S	5.76	0.47	8.24	18	2.1	4.98
20	5	R	5.46	0.42	7.64	15	1.5	5.00
20	10	S	10.39	1.11	10.69	19	4.6	5.00
20	10	R	7.16	0.84	11.68	18	4.0	5.00
Results using the cost function of Maurer et al. (2010) and Equation (5.2)								
N° of pipes (-)	Slope (%)	Material (-)	Total cost (USD) x10 ⁴	DM cost (USD) x10 ⁴	DM (%)	N° DM (-)	MDH (m)	Max V (m s ⁻¹)
10	5	S	43.94	4.83	10.99	8	1.7	5.00
10	5	R	39.87	2.97	7.44	5	1.1	4.99
10	10	S	62.05	12.35	19.90	9	4.2	5.00
10	10	R	54.08	8.20	15.16	8	3.6	4.99
20	5	S	115.02	11.77	10.23	18	2.1	5.00
20	5	R	107.58	9.73	9.05	15	1.5	5.00
20	10	S	153.38	26.38	17.20	19	4.6	5.00
20	10	R	140.01	20.09	14.35	18	4.0	5.00

Nomenclature:
S: smooth (null roughness).
R: rough (roughness = $3 \cdot 10^{-4}$ m).
DM cost: cost of the drop manholes.
DM: percentage of the cost of drop manholes in relation to total cost.
N° DM: number of drop manholes.
MDH: maximum drop height.
Max V: maximum velocity.

Table 5.2 shows that the designs with smooth material are more expensive than the ones with rough material in all cases. The difference in costs between the two materials may be because rough pipes dissipate more energy. Therefore, these lead to cheaper solutions when there is excess energy that must be dissipated in drop manholes.

As for drop manholes, in the series with the highest slope (10%), the cost of these structures represents a larger percentage with respect to the total cost. The reason is that in these series there are greater maximum drop heights, and the cost of manholes increases when the depth is greater.

Also, in Table 5.2, the maximum velocity in all configurations reaches the maximum allowable value (5 m s^{-1}) or a very close value. This happens because the series of pipes used as case studies seek

to imitate hilly regions and therefore have steep slopes where velocity tends to be high. These examples show that the use of drop manholes allows for designs that respect the hydraulic constraints that are difficult to meet in hilly regions, such as maximum velocity.

Finally, the obtained results from both cost functions were found to be very similar, indicating that the proposed cost function accurately represents the cost of drop manholes. Furthermore, the similarity in results suggests that the cost function has no significant impact on the methodology's overall performance.

To show an example of the results, Figure 5.4 presents the designs of the series with 10 pipes when using the cost function of Maurer et al. [19] and Equation (5.2).

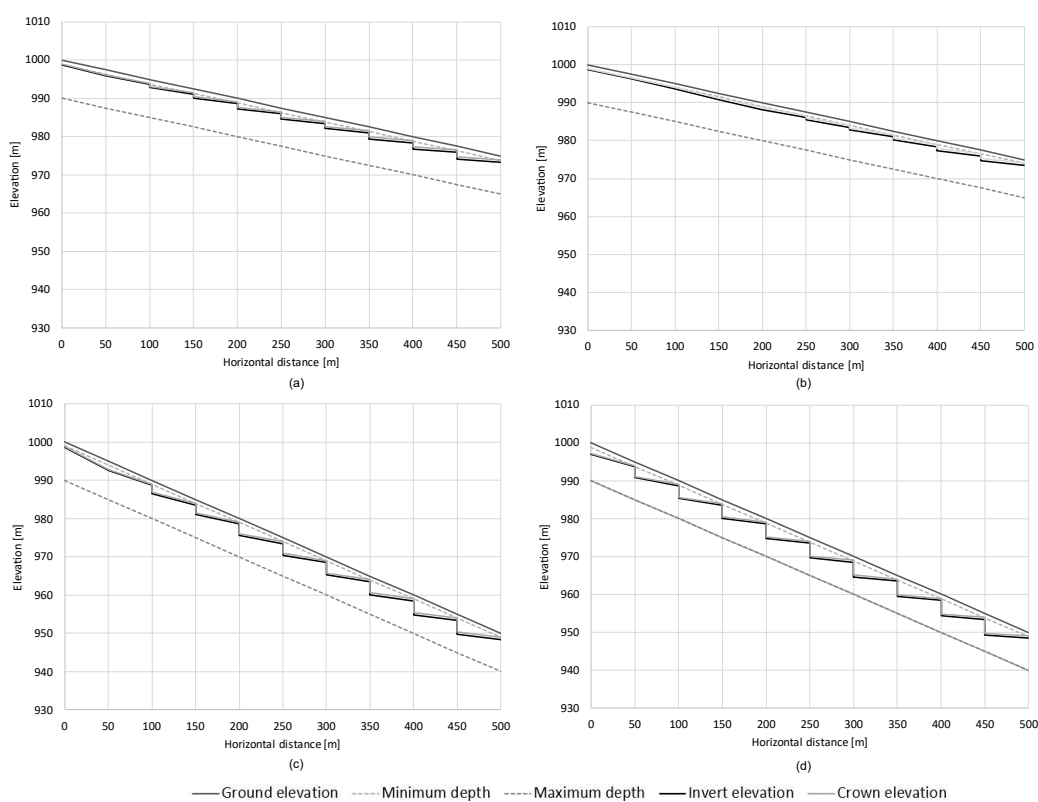

Figure 5.4. Design of series of pipes with a) 5% slope and smooth material, (b) 5% slope and rough material, (c) 10% slope and smooth material and (d) 10% slope and rough material.

5.5.2 Results in Chicó sewer network

The methodology was also tested on the aforementioned sewer network to show that it can work in more complex systems. The difference between a sewer network and a series of pipes is that the network has a three structure, which adds more variables to the design, such as pipe connection and flow direction. Table 5.3 presents the optimal designs obtained for six different configurations of the Chicó sewer network varying the slope and the material. Table 5.3 includes the results achieved with the two cost functions used in this work.

Table 5.3. Results in Chicó sewer network.

Results using the cost function of Li and Matthew (1990)							
Slope	Material	Total cost	DM cost	DM	N° DM	MDH	Max V
(%)	(-)	(CNY) x10 ⁴	(CNY) x10 ⁴	(%)	(-)	(m)	(m s ⁻¹)
5	S	26.14	0.57	2.19	20	3.3	5.00
5	R	25.62	0.25	0.97	9	2.8	4.99
5	VR	31.00	0	0	0	-	3.93
10	S	43.42	3.28	7.54	26	13.8	5.00
10	R	34.11	1.58	4.64	24	7.1	5.00
10	VR	27.89	0.03	0.11	1	0.7	4.93
Results using the cost function of Maurer et al. (2010) and Equation (5.2)							
Slope	Material	Total cost	DM cost	DM	N° DM	MDH	Max V
(%)	(-)	(USD) x10 ⁴	(USD) x10 ⁴	(%)	(-)	(m)	(m s ⁻¹)
5	S	713.37	14.34	2.01	20	3.3	4.99
5	R	703.20	5.59	0.79	9	2.8	4.99
5	VR	715.22	1.24	0.17	2	0.9	4.98
10	S	903.47	80.51	8.91	27	13.6	5.00
10	R	782.00	37.90	4.85	24	7.1	5.00
10	VR	737.16	0.69	0.09	1	0.7	4.93

Nomenclature:
S: smooth (null roughness).
R: rough (roughness = $3 * 10^{-4}$ m).
VR: very rough (roughness = $3 * 10^{-3}$ m).
DM cost: cost of the drop manholes.
DM: percentage of the cost of drop manholes in relation to total cost.
N° DM: number of drop manholes.
MDH: maximum drop height.
Max V: maximum velocity.

The results show that, rougher the material is, fewer drop manholes are required due to the energy dissipation performed in the pipes. However, a lower number of drop manholes does not always result in a cheaper design because the slope also influences this relationship. With the 5% slope, the designs with very rough material required the fewest number of drop manholes but cost the most. Nevertheless, in the designs with the 10% slope, the very rough material obtained the fewest number of drop manholes and the cheapest cost. The reason why the designs with very rough material were the most expensive in the case of the 5% slope network is because the pipes required larger diameters, as shown in Figure 5.5. These findings imply that the best material roughness depends on the land's slope. Recall the nomenclature in Figure 5.5: S is for smooth material (null roughness), R is for rough material (roughness = $3 * 10^{-4}$ m), and VR is for very rough material (roughness = $3 * 10^{-3}$ m).

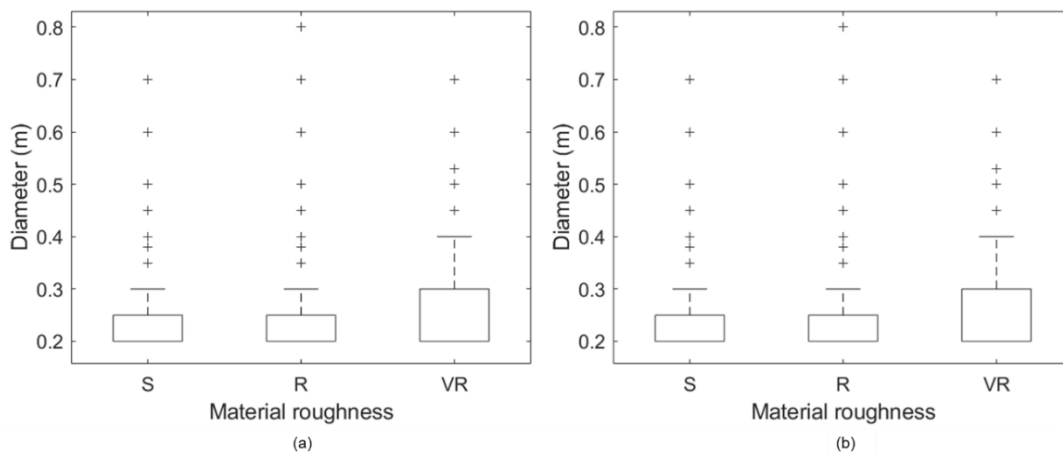

Figure 5.5. Box plot of diameters in designs of the Chicó network with a 5% slope using the cost function of a) Maurer et al. and b) Li and Matthew.

As for the maximum velocity, all designs comply with the maximum value allowed, but only the design with very rough material, 5% slope, and the Li and Matthew’s [14] cost function has a maximum velocity that is not very close to the maximum allowed. This may be the reason why this is the only design that did not require any drop manholes.

Finally, as with the results of the series of pipes, the results of the sewer network did not vary with the cost function. Any cost function could be used to perform the proposed methodology.

To illustrate the results, Figure 5.6 presents the design of one series of eight pipes in the Chicó network that starts with an outer-branch pipe and ends in the outfall. Figure 5.6a shows in bold arrows the series of pipes illustrated, and Figure 5.6b shows their respective elevations, where three drop manholes were obtained. The design presented corresponds to the one with a 5% slope, rough material, and the Maurer et al. [19] cost function.

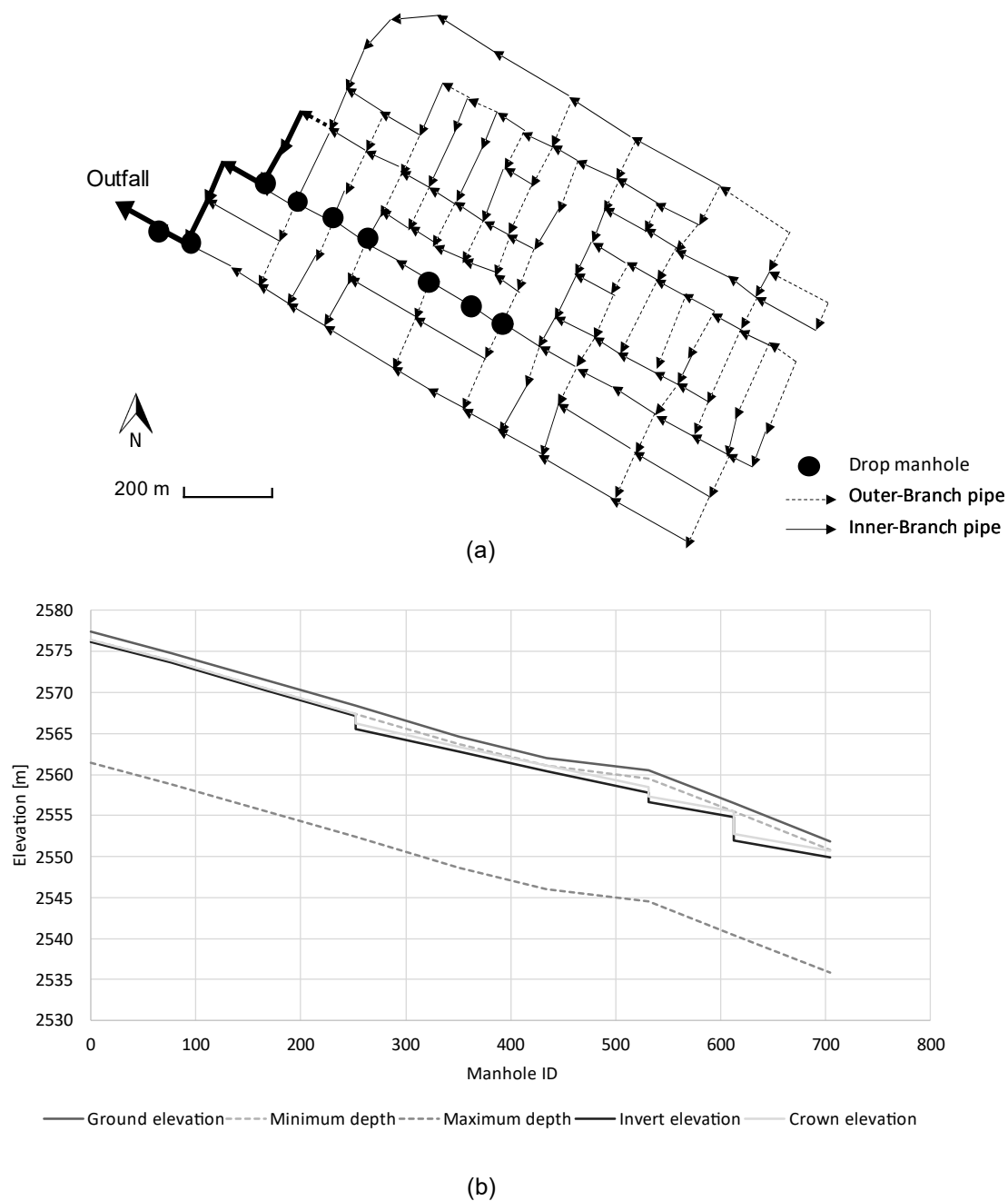

Figure 5.6. Illustration of the design of one series of pipes of the Chicó network. (a) Location of the series of pipes in the network (highlighted with bold arrows). (b) Design of the series of pipes of the Chicó network.

In the series presented in Figure 5.6b, three drop manholes were obtained. From left to right, its respective drop heights are 1.2 m, 1.2 m, and 2.8 m. Although only three drop manholes are presented in the series shown in Figure 5.6b, the complete network design has nine drop manholes, which are shown in Figure 5.6a. The entire design can be found in the supplementary material. It is also important to mention that in the case of the Chicó network, the minimum and maximum depths used were 1 m and 16 m, respectively.

5.5.3 Comparison with previous works

A comparison between the methodology proposed by Duque et al. [16], Saldarriaga et al. [17], and the methodology with the extension of drop manholes was presented by Saldarriaga et al. [21]. These authors tested the three methodologies in the Chicó sewer network with a 5% slope with the Li and Matthew [14] hydraulic constrains, the cost function of Maurer et al. [19], and a Manning's n of 0.014. The findings indicate that the methodology proposed by Duque et al. [16] resulted in a cost of \$8.96 million USD, while the methodology proposed by Saldarriaga et al. [17] had a cost of \$7.67 million USD. The extended methodology with drop manholes, proposed by Saldarriaga et al. [21], achieved the lowest cost of \$7.62 million USD.

In addition, in the present work a comparison between the mentioned methodologies was performed using the Chicó sewer network with a 10% slope and the same conditions used in the work of Saldarriaga et al. [21]. The results are presented in Table 5.4 where it is reported the construction cost and the average execution time of the hydraulic design model.

The results indicate that the drop manhole methodology was able to reduce the construction cost of the network compared to the other methodologies. The cost reduction was particularly significant in the 10% slope network due to the terrain's steepness, which made the drop manholes more crucial.

Table 5.4. Comparison between methodologies for sewer network design tested in the Chicó sewer network with 10% slope.

Research	Cost (USD x10 ⁶)	Execution time (s)
Duque et al. (2020)	\$ 21.03	4461.49
Saldarriaga et al. (2021)	\$ 12.10	292.24
Extension with drop manholes	\$ 7.21	408.78

In terms of execution time, the methodology with drop manholes took more seconds to find the solution compared to the methodology proposed by Saldarriaga et al. [17]. This is because the algorithm had to evaluate the arcs modelling the drop manholes in addition to the arcs modelling pipes. On the other hand, the methodology proposed by Duque et al. [16] required the longest computational time due to the need for a very large maximum excavation depth to find the solution. This resulted in a greater number of arcs that the algorithm had to evaluate.

5.5.4 Sensitivity analysis of the discretization parameter ΔZ in the excavation depth of the methodology with the extension of drop manholes

The discretization parameter ΔZ establishes the fixed elevation change in the excavation depth, as shown in Figure 5.1 and Figure 5.2b. For example, if this parameter is equal to 0.1 m and the minimum depth is at an elevation of 100 m, the depths that the algorithm must evaluate (in meters)

will be: 100, 100.1, 100.2, ... and so on until the maximum depth is reached. These depths correspond to the excavation depth of the start and end nodes of the arcs that represent pipes and drop manholes. From the above, it can be inferred that if ΔZ is smaller, the number of arcs will increase, the algorithm will evaluate more depths, and the accuracy of the results will be higher.

To evaluate the effect of ΔZ in the designs, a sensitivity analysis was performed on the methodology with drop manholes. As a case study, we used the Chicó network with a 5% slope and with smooth and rough material. The cost function used was Maurer et al.'s [19] for the pipes and Equation (5.2)(5.2) for drop manholes.

The sensitivity analysis was done with the ΔZ used in the case studies (0.1 m) and with a ΔZ of 0.025 m and 0.2 m. These values were chosen because using smaller values requires too much calculation time, while using larger values results in a high accuracy loss. Also, smaller values are not relevant because construction does not require such precision. Table 5.5 shows the costs, excavation time, and number of drop manholes for each design.

Table 5.5. Sensitivity analysis of parameter ΔZ in the methodology with drop manholes.

Material	Smooth			Rough		
	0.025	0.1	0.2	0.025	0.1	0.2
ΔZ (m)	0.025	0.1	0.2	0.025	0.1	0.2
Cost (USD) $\times 10^5$	71.05	71.40	72.48	69.70	70.34	71.08
Exe. Time (s) $\times 10^3$	54.45	1.16	0.70	5.93	0.45	0.20
N° of DM	20	20	21	9	9	9

According to the sensitivity analysis, the cost of the design decreases as the algorithm's accuracy increases. This is due to the algorithm evaluating more alternatives, allowing it to achieve a better design. However, as the algorithm's accuracy increases, so does its execution time. Furthermore, the decrease in cost is not proportional to the increase in execution time. For example, when comparing the results of using ΔZ of 0.2 and 0.025, the cost decreased by around 2%, while the time increased by about 97% for both materials. On the other hand, it was found that while accuracy has no effect on the number of drop manholes obtained in the design, material does.

5.6 Conclusions

This work proposes an optimal design methodology for sewer systems that includes drop manholes. These structures allow the implementation of optimal design methodology in hilly regions where drop manholes are required to dissipate energy and comply with the maximum velocity constraint.

To include drop manholes in the methodology, it is proposed to add a new type of arc in the hydraulic design graph, called arc type 2. These arcs model the possible drop heights in the manholes so that the shortest path algorithm considers the possibility of having a drop manhole when selecting the lowest-cost design.

Two cost functions were used to model the cost of sewer systems, one proposed by Li and

Matthew [14] and another proposed by Maurer et al. [19]. Since the latter only models the cost of pipes, in the present work a cost function for drop manholes was developed to use it with the function of Maurer et al. This function was obtained with a multiple regression from the designs obtained with the Li and Matthew [14] cost function. This regression relates the drop manhole cost, the depth of excavation of the manhole, and the diameter of the pipe exiting the manhole. This regression achieved a R^2 of 0.99.

The methodology was tested in eight configurations of series of pipes and a sewer network, varying the material, the slope, and the number of pipes for the case of the series. From the results obtained, the main conclusions of this work can be highlighted:

- The proposed methodology allows for the optimal design of sewer systems in hilly regions, where it would not be possible to design a sewer system that complies with all the hydraulic constraints without including drop manholes in the design.
- Drop manholes can be modelled as an arc in a graph that represents a drop height between an upstream and downstream pipe. These arcs are represented by the junction of two nodes with different excavation depths.
- The cost function proposed to model the drop manholes' cost in dollars proved to be an adequate representation of costs, since the results with this cost function were very similar to the results achieved with the cost function of Li and Matthew (1990). The above proves that the methodology works with any cost function.
- The effect of the material roughness on the cost of the network depends on the slope of the terrain. The results suggested that there is an optimal combination between the slope and the material roughness.
- The roughness of pipes aids in energy dissipation. The rougher the material, the fewer drop manholes are required.
- A lower discretization parameter in the excavation depth (ΔZ) denotes a higher algorithmic accuracy, which allows for designs with lower costs but a longer computational time requirement. This parameter proved to have no effect on the number of drop manholes obtained in the designs.

In future work, with the proposed method of using new types of arcs that do not represent pipes, other structures of sewer networks can be incorporated into the optimal design methodology. For example, pumping stations, since they are important structures in flat regions, or combined sewer overflows (CSOs) could be included. Furthermore, strategies to decrease the computational time required in each iteration could be useful because by including new arcs in the methodology, the solution space increases and, therefore, greater computational resources are required to reach the optimum design.

Acknowledgments

The authors would like to thank Andrea Marú and Cristian Cardona for their contributions in the development of the methodology for sewer network design with drop manholes and Ana Acevedo for her assistance in the execution of the results presented.

Disclosure statement

The authors declare no conflict of interest.

This supplementary material presents the input data and the complete designs of the case studies used in the article. To reduce the extension of the supplementary material, only the designs achieved with the cost function of Li and Matthew [14] are presented here; however, the designs achieved with the cost function of Maurer et al. [19] are available by contacting the authors. The supplementary material also includes the multiple regression plot of the proposed cost function for drop manholes.

Nomenclature

- \mathcal{E} = set of edges that represent all feasible links between manholes.
- a_{ij} = estimation of the cost associated with using a pipe with flow direction m_i to m_j .
- \mathcal{A}_D = set of arcs in the hydraulic design graph.
- \mathcal{A}_L = set of directed links between two nodes.
- b_{ijt} = parameter to consider land topography in the layout selection model.
- c_{ij} = estimated cost per flow unit in the pipe from m_i to m_j .
- C_{dmh} = drop manhole cost
- d = pipe diameter (m).
- h = excavation depth (m).
- L = pipe length (m).
- \mathcal{M} = set of nodes that represents manholes.
- \mathcal{N}_D = set of nodes of the hydraulic design graph.
- q_{ijt} = non-negative real variable that represents the flow rate in the pipe of type $t \in \mathcal{T}$ that goes from m_i to m_j .
- \mathcal{T} = set of types of pipes.
- v_i^k = One node of the hydraulic design graph.
- x_{ijt} = binary variable that takes the value of one (1) if the pipe defined from m_i to m_j with connection type $t \in \mathcal{T}$ is part of the layout solution.
- Z_{min} = minimum excavation limit (m).
- Z_{max} = maximum excavation limit (m).
- ΔZ = discretization parameter of excavation depth (m).

6. Sewer network design methodology for low-cost, resilient, and reliable designs

Preamble

This Chapter 6 presents the last in the series of four articles devoted to presenting an innovative approach of achieving minimum-cost design of sewerage systems. The solution to the optimized design problem was achieved by dividing the problem into two parts. On the one hand, the determination of the layout that would bring the design closer to its optimum, using a Mixed Integer Programming model complemented with geometric and power criteria. On the other hand, the optimal hydraulic design using the Bellman-Ford algorithm. The methodology developed allows the use of any structure that is part of the sewerage network, such as drop manholes, spillways, pumping stations, and more. A minimum-cost network is designed to transport a design flow, representing either the wastewater flow corresponding to a future population in the case of sanitary system or a rainfall event with a high return period for stormwater systems. However, that design flow may be exceeded, for example, by new rainfall conditions due to Climate Change, or accelerated population growth. Therefore, the design process should not only look at the minimum cost but also at the reliability and resilience of the network to operate in different hydraulic scenarios. Reliability and resilience are two concepts that have a positive correlation but they are not the same, since there may be sewer designs with maximum resilience that do not necessarily give maximum reliability. In this paper a methodology was proposed to evaluate the resilience, reliability and cost in sewer system design obtained through the optimal design methodology presented in the previous chapters, with the objective of finding low-cost designs, but with high resilience and reliability. It was proven that low-cost designs are not necessarily not very resilient or reliable. Low-cost designs, close to the minimum cost optimum, were found that also had high resilience or reliability. The conclusion is that it is possible to find low-cost designs with high resiliencies, making use of optimization methodologies.

The reference of this paper is:

Saldarriaga, J.; Herrán, J. Sewer Network Design Methodology for Low-Cost, Resilient, and Reliable Designs. *Urban Water Journal* **2023**, *20*, 943–952, doi: <https://doi.org/10.1080/1573062x.2023.2218339>.

6.1 Introduction

The sewer network design problem can be divided into two subproblems: the layout selection and the hydraulic design. The layout selection establishes the tree-structure of the network, which is composed of different sized series of pipes and indicates the flow rate and flow direction in pipes. On the other hand, the hydraulic design determines the diameter and the upstream and downstream invert elevations of pipes. The objective of the sewer network design problem is to find the solution

of the two subproblems that lead to the lowest cost design, i.e. the optimal design. This is a complex task due to the immense number of feasible solutions, and because of the presence of discrete variables, such as the diameter of pipes that depend on the commercially available list of diameters.

Due to the complexity of the problem, finding the optimal sewer network design has become a challenge for the researchers of the field. Among the first authors to propose a method to solve the problem were Li and Matthew [1], who selected the layout of the network with the searching direction method and used Discrete Differential Dynamic Programming (DDDP) for the hydraulic design. These authors also presented a sewer network that has become a popular benchmark in the international literature. Another approach was the proposed by Moeini and Afshar [2-4] who intended using Ant Algorithms combined with the Tree Growing Algorithm (TGA) and Nonlinear Programming (NLP) for the layout selection and hydraulic design of sewer networks. Also, Haghighi and Bakhshipour [5] used the loop-by-loop cutting algorithm for the layout selection and Tabu Search (TS) for the hydraulic design. Duque et al. [6] used mixed-integer programming (MIP) for the layout selection and Dynamic programming (DP) for the hydraulic design. Saldarriaga et al. [7] included topographic criteria to the last methodology which managed to obtain the lowest cost designs published in the literature for the Li and Matthew network. Other studies that solve both subproblems of the sewer network design problem include Diogo and Graveto [8]; Haghighi and Bakhshipour [9]; Navin and Mathur [10]; Steele et al. [11]; Alfaisal and Mays [12].

Although it is important to minimize the cost of sewer networks, over the past decades, new challenges that threaten the service of sewer systems have emerged, such as climate change and high-density urbanization, which may alter operating flow rates and result in flooding. For this reason, incorporating concepts like reliability and resilience is important to provide a better service in sewer networks.

The reliability and resilience are two concepts that have positive correlation but are not the same. Alternatives that give the greatest resilience do not necessarily provide the greatest reliability (Asefa et al. [13], as cited in Sweetapple et al. [14]). According to Butler et al. [15], the reliability is defined as “the degree to which the system minimizes level of service failure frequency over its design life when subject to standard loading”, while the resilience is defined by the US National Infrastructure Advisory Council (NIAC) [16] as “the ability to reduce the magnitude and/or duration of disruptive events.”

The reliability of sewer networks has been studied in previous works. For example, Mista-Kruk [17] analysed the reliability related to elements of pressure, vacuum and gravity systems based on data; Tee et al. [18] estimated the reliability with respect to corrosion in pipes, and to consider the reliability in the design of the network; Haghighi and Bakhshipour [19] proposed a reliability index that depends on the layout of the network. As for the resilience, many works have proposed methodologies to measure this concept, most of them using flooding volume (Kwon et al. [20]; Lee et al. [21]; Lee and Kim [22]; Lee et al. [23]; Chen and Leandro [24]; Mugume et al. [25]). From these methodologies, the proposed by Mugume et al. stands out for its simplicity and easy implementation in any sewer network.

The present work proposes an approach to evaluate resilience, reliability, and cost in sewer networks designs obtained with an optimal design methodology. The approach aims to be a tool for

finding low-cost designs with high resilience and reliability. It also seeks to allow the analysis of the relationship between these three aspects in sewer networks. The proposed methodology was applied in two sewer networks that have been used before in the literature to test sewer network design methodologies. The methodology was also tested using two cost functions from the literature. To summarize, the contributions of the proposed work are:

- Create a methodology that incorporates resilience, reliability, and cost into a single framework for selecting the most desirable sewer network design based on these criteria.
- Develop a multi-criteria methodology for sewer network design that uses MIP and DP to minimize the cost of each evaluated solution, which guarantees optimality in contrast to other algorithms such as metaheuristics.
- Perform a correlation analysis to better understand the relationship between sewer network resilience, reliability, and cost.

6.2 Methodology

6.2.1 Optimal sewer network design

The methodology used to find optimal sewer networks designs was the proposed by Saldarriaga et al. [7], which is an extension of the methodology of Duque et al. [6]. This methodology proposes to solve the layout selection with a MIP model and the hydraulic design with a DP algorithm. The advantage of using MIP and DP is that, unlike metaheuristics, these algorithms guarantee optimality. i.e., the MIP model ensures that the chosen layout optimizes the given objective function, while the DP algorithm ensures that the achieved hydraulic design is the one with the lowest cost for the given layout.

6.2.1.1 Layout Selection: Mixed-integer programming with the topographic criteria extension

For the layout selection, a MIP model is used to select the flow direction, flow rate, and type of connection of pipes. There are two types of connection of pipes, outer-branch pipes, and inner-branch pipes. The former corresponds to the first upstream pipe in a series, and the latter are the rest of the pipes.

The MIP model has two decision variables: x_{ijt} , that is a binary variable that takes the value of 1 if the pipe is part of the layout; and q_{ijt} , that is a nonnegative real-valued variable that represents the flow rate in the pipe. The model selects the value of the variables that minimize Equation (6.1) and that comply with the constrains that guarantee a feasible layout.

$$OF = \min \left(\sum_{t \in \mathcal{J}} \sum_{(i,j) \in \mathcal{A}_L} c_{ij} q_{ijt} + \sum_{t \in \mathcal{J}} \sum_{(i,j) \in \mathcal{A}_L} a_{ij} x_{ijt} + \sum_{t \in \mathcal{T}} \sum_{(i,j,t) \in \mathcal{A}_L} b_{ijt} x_{ijt} \right) \quad (6.1)$$

Equation (6.1) is the objective function of the model, where c_{ij} is an estimate of cost per flow unit, a_{ij} is an estimate of the cost of selecting a flow direction, and b_{ijt} is a parameter that allows including the topography as a criterion for selecting the network layout. c_{ij} and a_{ij} are calculated with

a linear regression between the flow rate and the cost per unit length of pipes, while b_{ijt} is estimated using the following topographic criteria:

- Topographic criterion 1: Parameter b_{ijt} is calculated as the multiplication of the section's land slope (s_{ijt}), minus 1, and a penalty (μ) that gives priority to inner-branch pipes, as shown in Equation (6.2).

$$b_{ijt} = s_{ijt} * -1 * \mu \quad (6.2)$$

The original methodology recommended the values shown in Equation (6.3) for μ , which were chosen through a sensitivity analysis. However, in the present work, the values of μ were modified to achieve a variety of layouts. This will be explained later in the methodology.

$$\mu = \begin{cases} 0.65, & s_{ijt_1} > 0 \\ 1.65, & s_{ijt_1} < 0 \end{cases} \quad (6.3)$$

- Topographic criterion 2: This is a power-based criterion that works the same way as Topographic criterion 1, but the land slope is also multiplied by the length of the pipe (L_{ij}), as shown in Equation (6.4). This topographic criterion also gives priority to inner-branch pipes through the penalty μ .

$$b_{ijt} = s_{ijt} * L_{ij} * -1 * \mu \quad (6.4)$$

- Topographic criteria 3: b_{ijt} is calculated as the distance between the downstream manhole of the pipe and the outfall of the network. This topographic criterion does not use the penalty μ .

The methodology performs an iteration with each topographic criterion mention above; this means that three solutions are obtained, one in each iteration. The solution with the lowest cost is selected as the base of a fourth iteration that tries to reduce the cost even more. In the fourth iteration, b_{ijt} is estimated as the cost of the expected excavation in each pipe. The expected excavation is calculated with the land slope and the average pipe slope of the solution with the lowest cost selected from the first three iterations as shown in Equation (6.5), where S_{mean} is the average pipe slope, S_{ijt} is the sections's land slope, L_{ij} is the length of the pipe, and h_{ijt} is the expected excavation of the section.

$$h_{ijt} = \frac{S_{mean} - S_{ijt}}{2} * L_{ij} \quad (6.5)$$

Finally, if the fourth iteration manage to reduce the cost, its layout is selected as the solution of the problem, otherwise, the layout of the solution with the lowest cost from the first iterations is selected as the final solution of the problem.

6.2.1.2 Hydraulic design: Dynamic Programming

Once the layout of the network is selected, the hydraulic design of the network is performed. This

consists of deciding the diameter and the upstream and downstream invert elevations of pipes. A Shortest Path Algorithm (SPA) is used to find the optimal combinations of diameters and invert elevations for the network. It is important to note that this algorithm guarantees to find the optimal design for the selected layout, that is, the design with the lowest cost.

The methodology used in this work models the hydraulic design as a graph composed of nodes and arcs. The nodes are located in the manholes of the system and represent the possible combinations of diameters and invert elevations, where the diameters correspond to the upstream pipe of the manhole. The arcs represent the feasible joints between nodes, considering that hydraulic restrictions must be met to ensure proper operation of the system, such as minimum and maximum flow velocity, maximum filling ratio, among others. The feasible arcs also ensure that the downstream diameter and invert elevation are larger or equal to the upstream diameter and invert elevation, since this avoids clogging and guarantees a gravity-driven flow system.

Each arc has an associated cost depending on the diameter of the downstream node and the average invert elevation of the upstream and downstream nodes. A SPA is used to find the optimal combination of diameters and depths. This algorithm evaluates all feasible arcs and selects the one with the lowest cost for each pipe in the system. Figure 6.1 illustrates an example of a small network with its respective nodes and arcs. In the figure, the outer rectangle represent the manholes; the rectangles and circles inside the manholes represent the possible invert elevations and diameters, respectively. The arrows between the manholes illustrate the arcs that model the feasible combinations between invert elevations and diameters. Finally, the dark circles and arrows represent the solution that was selected by the SPA. Note that Manhole 1 is composed of two structures in the figure, this is because the pipes coming from this manhole are outer-branch pipes, that means that two series of pipes starts in Manhole 1.

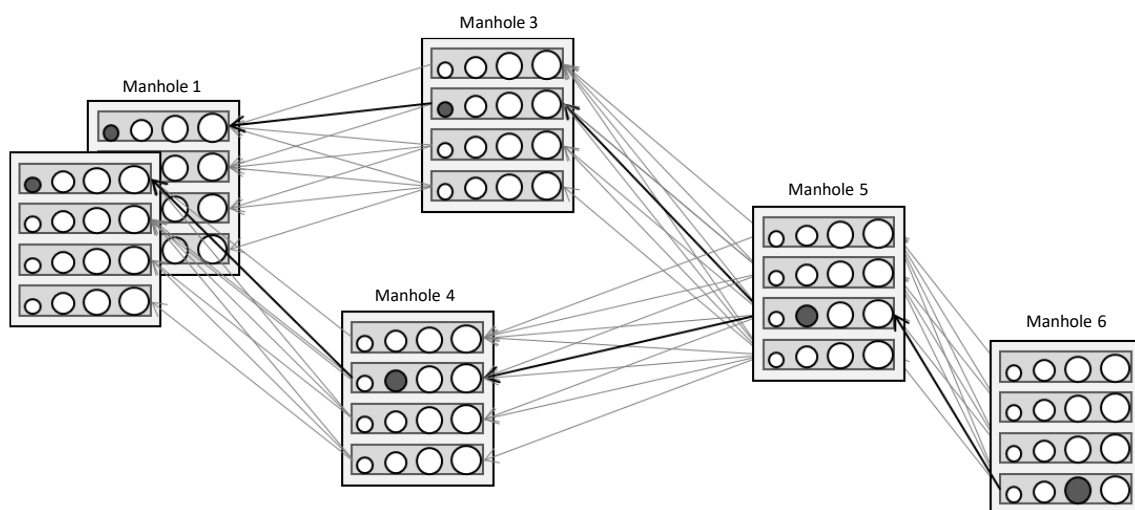

Figure 6.1. Hydraulic design graph. Adapted from "Sewer Network Layout Selection and Hydraulic Design Using a Mathematical Optimization Framework" by Duque et al. [4].

In the hydraulic design model, the designer must choose the pipe material, the list of available diameters, the cost equation, the hydraulic equation for calculating the flow velocity and the hydraulic

restrictions that the design must comply with. The conditions used to obtain results in this work are mentioned in the case study section.

6.2.2 Reliability index

To measure the reliability of the sewer networks designs, the index proposed by Haghghi and Bakhshipour [3] was used. This index tries to measure the consequences of a clogging pipe with the configuration of the layout of the network. That is, the index does not depend on the hydraulic design.

This index assumes that the impact of a clogged pipe will increase with the amount of flow the pipe carries. As a result, the authors define a pipe's reliability as 1 minus the flow rate carried by the pipe over the network's outfall flow rate, as indicated in Equation (6.6), where R_i is the reliability of pipe i , Q_i is the flow rate of pipe i , and Q_{out} is the outfall flow rate of the network.

$$R_i = 1 - \frac{Q_i}{Q_{out}} \quad (6.6)$$

For the entire network, the reliability is calculated as the average of the pipes reliability, as shown in Equation (6.7), where ARI is the average reliability index, and m is the number of pipes in the network.

$$ARI = 1 - \frac{\sum Q_i}{mQ_{out}} \quad (6.7)$$

Only the inner-branch pipes were taken into account for calculating the *ARI* in the present work, since Haghghi and Bakhshipour suggested this as one of their methods for increasing the index's sensitivity to the layout configuration.

The presented reliability index has the advantage of calculating network reliability by only considering layout variables; thus, it allows estimating network reliability without the hydraulic design. Also, in previous work, the performance of several indexes was evaluated, including new proposed indexes such as the number of outer-branch pipes in the layout of the network. However, the presented index proved to be the most sensitive to changes in the layout, which is why it was selected for the present study.

6.2.3 Resilience index

To measure the resilience of the network, the index proposed by Mugume et al. [25] adapted for steady flow was used. This index is calculated with a simulation of the operation of the network to estimate the magnitude and duration of floods if they occur. The original index is presented in Equation (6.8), where Res_o is the resilience index, V_{TF} is the total flood volume, V_{TI} is the total inflow volume into the system, t_f is the flood duration, and t_n is the total elapse time of the simulation.

$$\text{RES}_o = 1 - \frac{V_{\text{TF}}}{V_{\text{TI}}} * \frac{t_f}{t_n} \quad (6.8)$$

To adapt the index to steady flow, the flood duration was assumed to be equal to the elapse time, so the index was used as shown in Equation (6.9). We did this because we wanted to use case studies from the literature in which the manholes have a single inflow value rather than a hydrograph.

$$\text{RES}_o = 1 - \frac{V_{\text{TF}}}{V_{\text{TI}}} \quad (6.9)$$

In order to have a more sensitive index, the resilience index, like the reliability index, was calculated using only the inner-branch pipes. The process used to calculate the network's resilience was to calculate the resilience of a pipe with the flood volume obtained by simulating the pipe's clogging. This procedure was repeated for each inner-branch pipe, and the average resilience of these pipes was calculated to determine the network's resilience.

The pipe clogging simulation was carried out in SWMM 5.1 software (Rossman [26]) assigning a large roughness (Manning's $n=100$) to the pipe to be clogged. This is the same roughness used by Mugume et al. in their work.

The described resilience index was chosen for this study because it was considered that measuring the magnitude of the failure event through the flood volume is an adequate approximation that allows measuring resilience in a physical way. In addition, the index can be calculated in a simple way from failure simulations in the different designs to be evaluated.

6.2.4 Evaluation of resilience and reliability in sewer networks designs

In previous studies, a multiobjective optimization model was performed to minimize the cost and maximize the reliability in sewer networks designs. However, since the obtained solutions did not follow a Pareto Front, the results suggested that there is no trade-off between cost and reliability; that is, while the designs are more expensive, they are not necessarily more reliable.

Based on these results, in the present paper it is proposed a methodology in which multiobjective optimization is not used, but instead, a reliability measurement is performed on a variety of designs for the same network. The low-cost and high-reliability designs are sought without the use of a multiobjective algorithm. Furthermore, the concept of resilience is included in the analysis because it integrates reliability with the magnitude and/or duration of a failure event.

This proposed methodology consists of the evaluation of the resilience and reliability of various minimum cost sewer network designs with different layouts. The layouts were obtained by modifying the parameter b_{ijt} in the objective function of the layout selection (Equation (6.1)). Recall that each layout leads to a different hydraulic design.

Initially, the four designs corresponding to the iterations of the original methodology of Saldarriaga et al. were made. From these, new designs were obtained by modifying the parameter b_{ijt} . The modifications were made depending on how the parameter was originally calculated. In the case of the designs found with criterion 1 or 2, the modification consisted of changing the value of the penalty μ . In the case of criterion 3 and the fourth iteration, the way in which the distance and excavation costs were calculated were modified, respectively.

When parameter b_{ijt} was changed, it was found that there was no relationship between the magnitude of the modification of b_{ijt} and the cost of the resulting design. This means that it is impossible to predict whether the cost of the design will increase or decrease with the modifications of b_{ijt} . Furthermore, it was found that the same design could be achieved many times using different modifications in b_{ijt} . As a result, the value of the modification made in b_{ijt} was randomized until the desired number of designs was obtained.

Moreover, we attempted to obtain a range of costs in the new designs in order to investigate the relationship between cost, resilience, and reliability. To search for low-cost designs, the designs of iterations with lower costs were used as a basis, and vice versa, to search for high-cost designs, the designs of iterations with higher costs were used as a basis.

After obtaining the desired number of designs, the resilience calculation was performed. To do this, the design was first modeled in SWMM. Then, the flood volume obtained by clogging each of the inner-branch pipes of the network was calculated. Next, the resilience of each pipe was calculated with the flood volume and inflow volume of the network. Finally, the resilience of the network was calculated as the average of the resilience of the inner-branch pipes. After that, reliability was calculated for the same designs using the Haghghi and Bakhshipour index. The results were organized into two graphs, one of cost vs. resilience and the other of cost vs. reliability.

Figure 6.2 summarizes the methodology followed to obtain one sewer network design with its respective resilience and reliability. This process was repeated for each design evaluated; each time changing the modification of b_{ijt} to obtain a different design. The process can be followed as many times as wanted to achieve the desired number of designs.

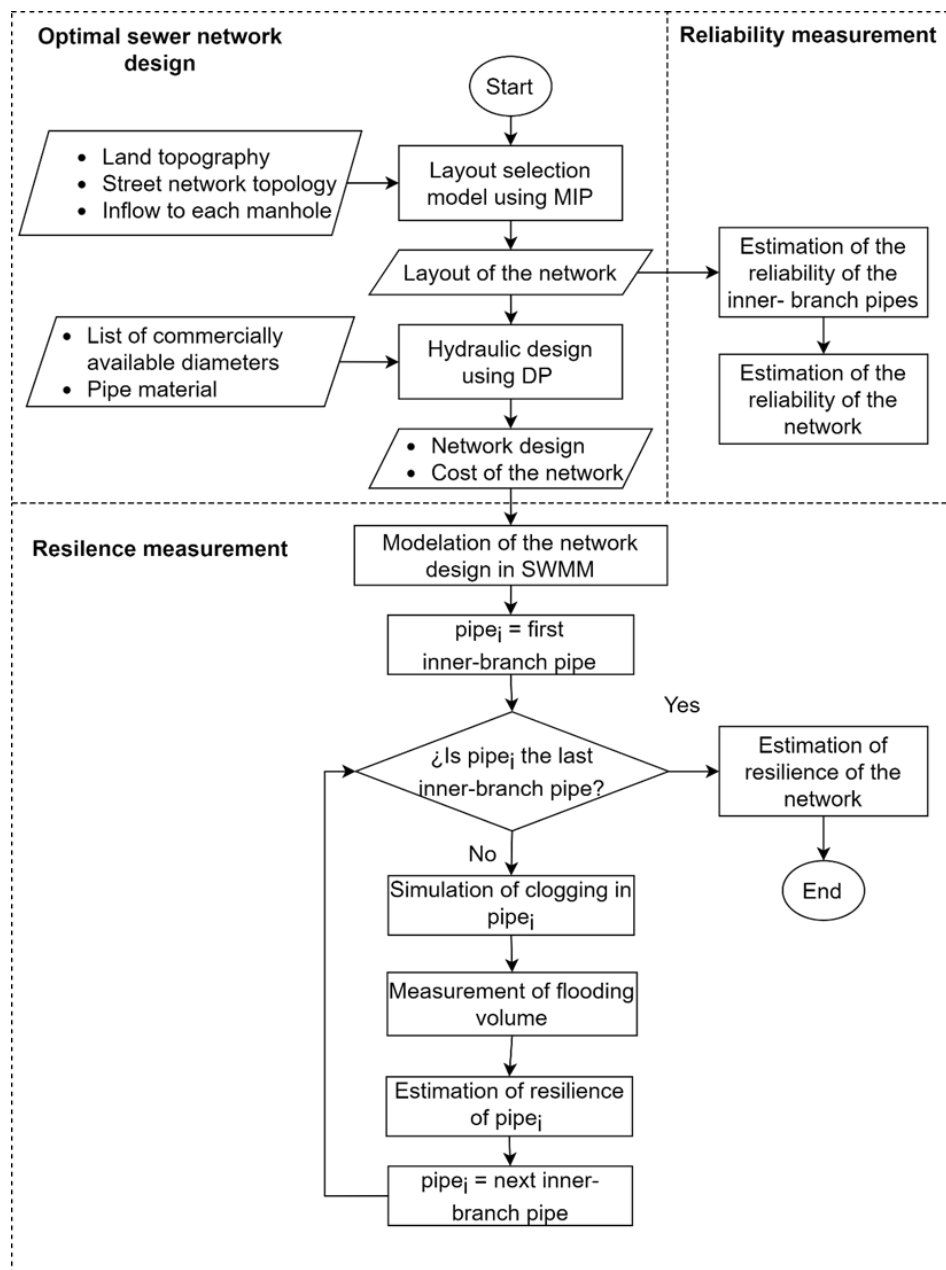

Figure 6.2. Methodology for optimal design, as well as resilience and reliability measurement for one sewer network solution.

In the present work, 15 designs were evaluated in each case study. The 15 designs are composed of:

- 10 of the designs achieved with the modification in b_{ijt} , following the methodology explained in Figure 6.2.
- 4 designs were obtained in the iterations of the methodology of Saldarriaga et al. [7].
- 1 design was the result of the methodology of Duque et al. [6].

The designs of the previous methodologies were obtained from the supplementary material of the respective works as well as by contacting the authors. In these designs, cost, resilience, and reliability were calculated with the same equations used in the 10 designs achieved with the methodology presented in Figure 6.2.

Finally, the methods used to design sewer networks and determine resilience and reliability are summarized in Table 6.1.

Table 6.1. Summary of the methodologies involved in this work.

Aspect	Method	Researches
Optimal sewer network design	MIP and DP	Duque et al. [6]
	MIP and DP extension	Saldarriaga et al. [7]
	MIP and DP extension with modifications in b_{ijt}	Present work
Reliability measurement	Reliability index only considering inner-branch pipes	Haghighi and Bakhshipour [3]
Resilience measurement	Resilience index only considering inner-branch pipes	Mugume et al. [25]

6.3 Case studies

The methodology was tested in two sewer networks previously used in the literature as case studies. The first one is labelled *Chicó* and is part of the real sewer network of Bogotá, Colombia. This sewer network is composed of 109 manholes and 160 pipes, and it only has one outfall with a total flow rate of $1.525 \text{ m}^3\text{s}^{-1}$. The other sewer network is the one proposed by Li and Matthew, which is composed of 57 manholes, 79 pipes, and one outfall with a total flow rate of $0.338 \text{ m}^3\text{s}^{-1}$. The structure, location of nodes, and input data of these sewer networks can be found in the supplementary material.

The sewer network design methodology must comply with the required hydraulic constrains to ensure proper operation of the network, this constrains change according to the regulation in each country. In the case of the present work, the constrains proposed by Li and Matthew [1] were used; these are presented in Table 6.2.

Table 6.2. Hydraulic constrains.

Constraint	Value	Condition
Minimum diameter	0.2 m	Always
	0.6	$d \leq 0.3 \text{ m}$
	0.7	$0.35 \text{ m} \leq d \leq 0.45 \text{ m}$
	0.75	$0.5 \text{ m} \leq d \leq 0.9 \text{ m}$
Maximum filling ratio	0.8	$d \geq 1 \text{ m}$
	0.7 m/s	$d \leq 0.5 \text{ m}$ and Flow rate $> 0.015 \frac{\text{m}^3}{\text{s}}$
Minimum velocity	0.8 m/s	$d > 0.5 \text{ m}$ and Flow rate $> 0.015 \frac{\text{m}^3}{\text{s}}$
Maximum velocity	5 m/s	Always
Minimum gradient	0.003	Flow rate $< 0.015 \frac{\text{m}^3}{\text{s}}$
Minimum depth	1 m	Always

The list of commercially available diameters used is: {0.2, 0.25, 0.3, 0.35, 0.38, 0.4, 0.45, 0.5, 0.53, 0.6, 0.7, 0.8, 0.9, 1.0, 1.05, 1.20, 1.35, 1.4, 1.5, 1.6, 1.8, 2, 2.2, 2.4} in meters, and the material used for pipes was concrete with a Manning's n equal to 0.014. The list of diameters and the material used are the same as those used in the previous sewer network design methodologies, which means that all the design constraints, and conditions are the same in the previous methodologies and in the present methodology.

As for the equations to model the construction cost of the sewer networks, two equations that have been previously used in the literature were implemented. One of them was proposed by Maurer, Wolfram, and Anja [27] and is presented in Equation (6.10), where C is the construction cost of one pipe in U.S. dollars, d is the diameter of the pipe in meters, L is the length of the pipe in meters, h is the average depth of the pipe in meters, and m_α , m_β , n_α , and n_β are constants equal to 110 US\$m⁻³, 1200 US\$m⁻², 127 US\$m⁻², and -35 US\$m⁻¹, respectively.

$$C = \left((m_\alpha d + n_\alpha)h + (m_\beta d + n_\beta) \right) * L \quad (6.10)$$

The other cost equation was proposed by Li and Matthew [1] and is presented in Equations (6.11), and (6.12) where f_p and f_m are the construction cost of a pipe and a manhole in yuan, respectively; d is the diameter of the pipe in meters (the downstream pipe in the case of Equation (6.12)), L is the length of the pipe in meters, and h is the buried depth in meters (average buried depth in the case of pipes).

$$F_p = \left\{ \begin{array}{ll} (4.27 + 93.59d^2 + 2.86dh + 2.39h^2)L & \text{if } d \leq 1 \text{ m and } h \leq 3 \text{ m} \\ (36.47 + 88.96d^2 + 8.70dh + 1.78h^2)L & \text{if } d \leq 1 \text{ m and } h > 3 \text{ m} \\ (20.50 + 149.27d^2 - 58.96dh + 17.75h^2)L & \text{if } d > 1 \text{ m and } h \leq 4 \text{ m} \\ (78.44 + 29.25d^2 + 31.80dh - 2.32h^2)L & \text{if } d > 1 \text{ m and } h > 4 \text{ m} \end{array} \right\} \quad (6.11)$$

$$f_m = \left\{ \begin{array}{ll} 136.67 + 166.19d^2 + 3.50dh + 16.22h^2 & \text{if } d \leq 1 \text{ m and } h \leq 3 \text{ m} \\ 132.91 + 790.94d^2 - 280.23dh + 34.97h^2 & \text{if } d \leq 1 \text{ m and } h > 3 \text{ m} \\ 209.74 + 57.53d^2 + 10.93dh + 19.88h^2 & \text{if } d > 1 \text{ m and } h \leq 4 \text{ m} \\ 210.66 - 113.04d^2 + 126.43dh - 0.60h^2 & \text{if } d > 1 \text{ m and } h > 4 \text{ m} \end{array} \right\} \quad (6.12)$$

The reason to use two cost function is because they have a different relation with the average excavation depth of pipes as shown in Figure 6.3. As part of the present work, we wanted to analyse if the way to estimate cost had an impact on the results.

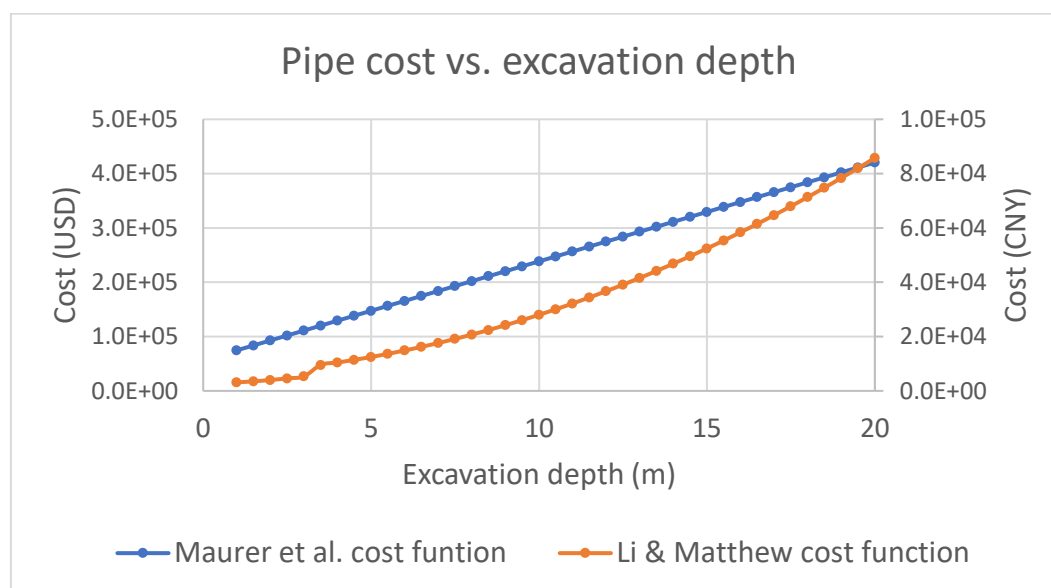

Figure 6.3. Relation between the excavation depth and the cost functions.

To resume, four scenarios were evaluated varying the sewer network and the cost function. These scenarios are summarized in Table 6.3. As mentioned before, in each scenario 15 designs were evaluated: 10 from the present methodology, 4 from the methodology of Saldarriaga et al. [7] and 1 from the methodology of Duque et al. [6].

Table 6.3. Evaluated scenarios.

Scenario	Sewer network	Cost function
1	Chicó	Maurer, Wolfram, and Anja
2	Chicó	Li and Matthew
3	Li and Matthew	Maurer, Wolfram, and Anja
4	Li and Matthew	Li and Matthew

6.4 Results

Figure 6.4 and Figure 6.5 present the results of the methodology. The results of scenarios where the Chicó sewer network was used are shown in Figure 6.4, while those using the Li and Matthew's are shown in Figure 6.5.

The results in each scenario are organized in two graphs: the graphs on the left present the cost vs. resilience of the 15 designs studied, and the graph on the right illustrate the cost vs. reliability of the same designs. The legend for the graphs is at the top of the figures and is the same for all the graphs.

The designs labelled as “MIP and DP” correspond to the designs achieved with the methodology of Duque et al. [6] The designs referenced as “MIP and DP extension” correspond to the solution of the 4 iterations of the methodology proposed by Saldarriaga et al. [7] The remaining 10 designs correspond to those achieved in the present work.

Also, the design considered as the “Best design” is marked with an “X”. The best designs are considered the ones with the lowest cost and highest resilience, or reliability. Selecting which design is the best can be subjective. It depends on how much cost the decision maker is willing to accept to increment the resilience or reliability. In the present work, the best designs were chosen with the authors criterion to illustrate an example of how the methodology can be useful to select designs with low cost and high resilience/ reliability.

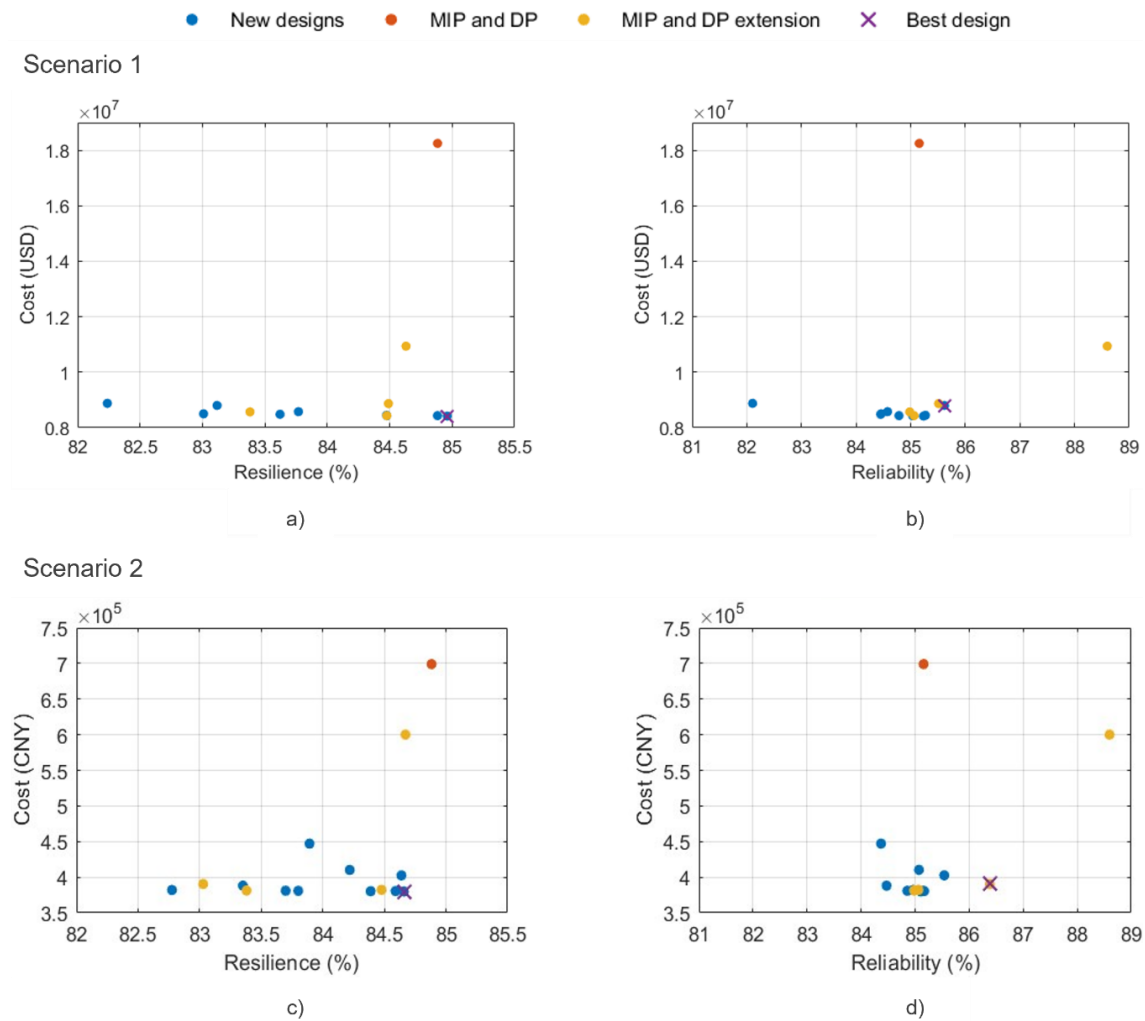

Figure 6.4. Results of the methodology in the scenarios where the Chicó sewer network was used.

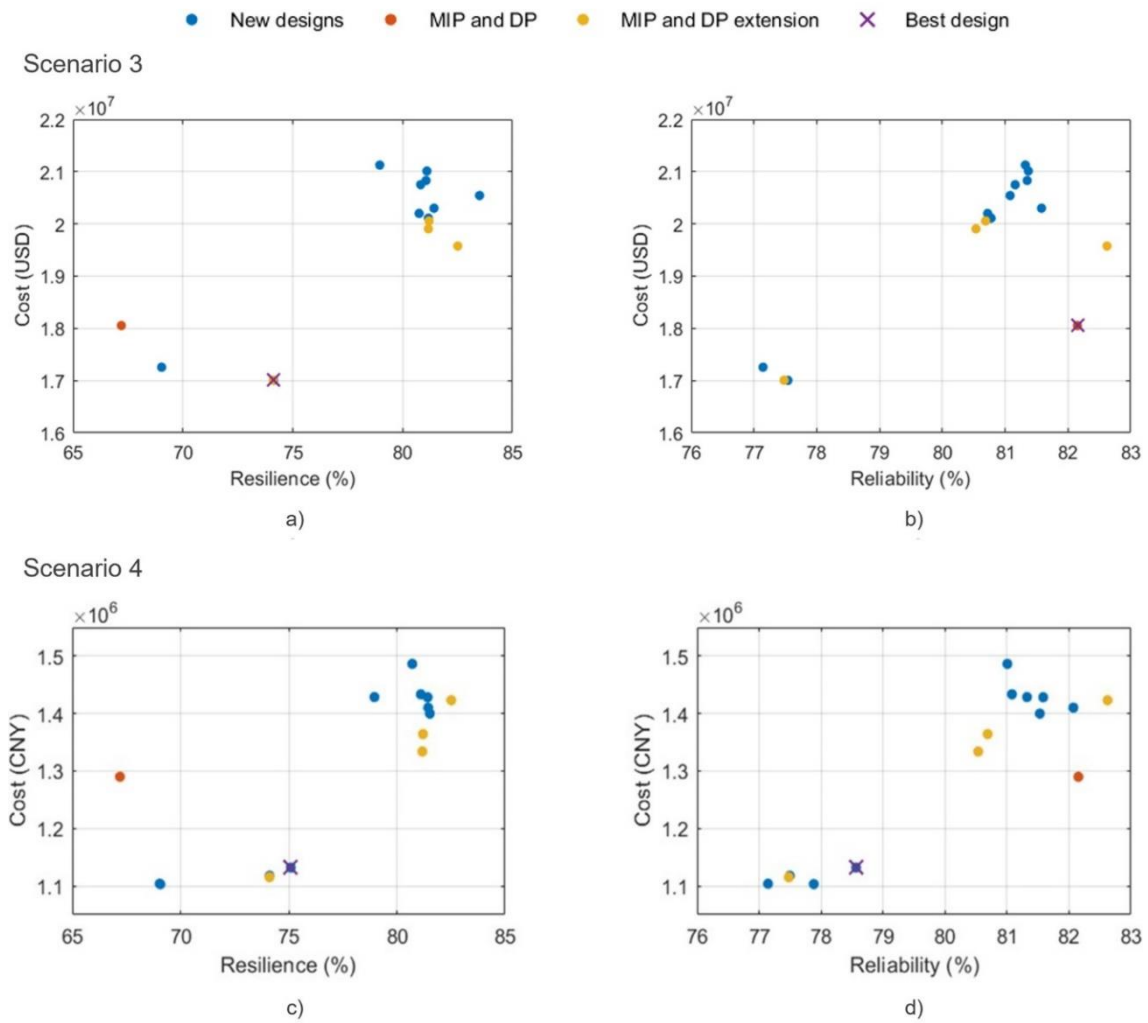

Figure 6.45. Results of the methodology in the scenarios where the Li and Matthew's sewer network was used.

Additionally, it was decided to analyse the correlation coefficient between the cost, resilience, and reliability of the designs. Table 6.4 presents these results for the four scenarios evaluated.

Table 6.4. Correlation matrix between cost, resilience, and reliability in the four scenarios.

Scenario		Correlation matrix		
		Cost	Resilience	Reliability
1	Cost	1		
	Resilience	0.285	1	
	Reliability	0.193	0.562	1
2	Cost	1		
	Resilience	0.459	1	
	Reliability	0.446	0.227	1
3	Cost	1		
	Resilience	0.808	1	
	Reliability	0.756	0.52	1
4	Cost	1		
	Resilience	0.789	1	
	Reliability	0.904	0.612	1

6.5 Discussion

In terms of the relationship between resilience and cost, Figure 6.4 and Figure 6.5 show that designs that are much more expensive are significantly more resilient. This is likely because costly designs typically have larger diameters and depths, which increase network capacity and reduce flood volume in the event of pipe clogging. However, when comparing designs with no significant cost difference, the most expensive design is not always the most resilient.

In addition, it was observed that having large excavation depths and diameters is not the only way to have high resilience, since very low-cost designs also achieved high resilience levels, as in the case of Figure 6.4a), where the lowest cost design is also the one with the highest resilience. This suggests that other elements, such as the network's layout, have a significant impact on the network's resilience.

As for the reliability, in the Li and Matthew network scenarios (Figure 6.5), the most expensive designs also had the highest reliability. In the Chicó network scenarios (Figure 6.4), however, the most expensive designs did not correspond to the most reliable designs. This result implies that the relation between the reliability and the cost may vary depending on the sewer network. The above is consistent

with the calculated correlation coefficients; in scenarios 1 and 2 the correlation is not very strong, while in scenarios 3 and 4 it is.

Furthermore, in the scenarios with the Chicó network, all designs had a reliability value of around 85%, indicating that the reliability index was not very sensitive to changes in the design, in contrast to resilience, which had a broader range of values in all the scenarios. This result indicates that resilience is more sensitive to changes in the sewer network design than reliability.

Also, in all scenarios, the methodology proposed in this article resulted in designs that were less expensive than those previously published. The cost reduction was minor; nevertheless, in the scenario with the smallest cost reduction (scenario 3), there was a cost reduction of \$ 3,217.39 USD. In addition, the lowest cost designs in scenarios 1, 2, and 3 are also more resilient than the lowest cost designs found using the preceding approaches. However, in all the scenarios, the designs obtained in this work failed to improve the previous designs in terms of reliability.

Finally, the two scenarios evaluated for each network are very similar to each other, indicating that the cost function did not have a significant impact on the results even though they have different relationships with respect to the depth of excavation.

The correlation coefficient between cost and resilience was positive in all scenarios, but it was close to 1 only when the Li and Matthew network was used, suggesting that the correlation between these two concepts is positive, but the strength of this relationship varies with each network.

Regarding the reliability, its correlation with cost was high in the scenarios where the correlation between resilience and cost was also high. This result is consistent with findings from earlier studies, which established that reliability is the foundation of resilience; as a result, it is expected that reliability improves as resilience does (Butler et al. [15]). The above can be seen in the correlation between resilience and reliability, which was positive in all scenarios but not close to one, indicating that, while they are related, they do not measure the same thing. In fact, the best designs in the resilience graph do not always correspond to the best designs in the reliability graph.

6.6 Conclusions

This paper proposes a methodology for integrating resilience, reliability, and cost criteria into a single framework for selecting the best sewer network design. In addition, the study aims to evaluate the relationship between the mentioned criteria. The following conclusions are presented based on the results obtained:

- Although the correlation between resilience and reliability is positive, it is not very strong; that is, the most resilient designs do not always correspond to the most reliable designs.
- Resilience is recommended over reliability when determining which design is more desirable, since this concept considers both reliability and the magnitude of the failure event. Furthermore, reliability is less sensitive to modifications in the network design.
- The correlation analysis showed that, contrary to common belief, cost is not always a criterion that conflicts with resilience and reliability. In all scenarios, the correlation between resilience and cost, and reliability and cost was positive, and it was especially strong in scenarios where the Li and Matthew's network was used.

- The methodology allowed for finding designs that were more resilient and less expensive than those that had already been published. This demonstrates that low-cost networks designs can be just as resilient as more expensive designs.

For future studies, it is recommended to use an algorithm that automates the process of finding new designs to take advantage of computer resources to explore a larger number of designs. Also, since very expensive designs were found to have higher resilience, it would be interesting to implement multiobjective optimization considering cost and resilience as objectives in future research. The challenge of this implementation is that resilience depends on both layout and hydraulic design, therefore, the model should integrate both subproblems.

Acknowledgment

The authors acknowledge Andrés Aguilar for his work in the conceptualization of the multiobjective optimization methodology and Laura Arroyo for her work in the analysis of reliability indexes.

Disclosure statement

No potential conflict of interest was reported by the author(s).

Supplementary material

The structure of the sewer networks used as case studies with its respective location of nodes, the input data of these sewer networks, and the detailed designs of the solutions labelled as “best designs” are presented in the supplementary material. Supplemental data for this article can be accessed <https://doi.org/10.1080/1573062X.2023.2218339>.

7. Discussion

Preamble

This chapter is dedicated to present a series of discussions related to the topic of optimized minimum cost design of urban sewer networks developed in this doctoral thesis. The first part discusses the delay in the state of development of the knowledge of this topic in relation to the urban infrastructure of drinking water supply. The new design constraints of a sewer network are discussed, which increase the complexity of the problem compared to that of drinking water. Then, the construction costs of both types of infrastructure are discussed to show that urban drainage leads to much more expensive systems. A discussion is then made on the methodology developed to achieve the minimum cost design of sewer systems, emphasizing its current scope, and then speculating on its future development. Finally, the resilience of an optimal sewer network is discussed and what topological changes should be implemented in order to increase it.

7.1 About the Optimal Design of Urban Drainage Systems

When the current state of knowledge on the subject of optimized design of drinking water distribution networks (WDN) is compared to the corresponding progress in the case of urban drainage networks (UDS), both for wastewater and rainwater, the gap is obvious. Today it can be considered that the minimum cost design of a WDN is a solved problem, which is not true in the case of the second mentioned infrastructure. This is contradictory to the fact that worldwide statistics show that drinking water service coverage is much higher than that of basic sanitation, a particularly serious problem in developing countries.

It is likely that this difference in the state of knowledge is because drinking water supply has traditionally been considered more important because of its implications for improving public health since the 1910s in both the United States and Europe. Today that difference still persists; if one compares the number of publications in peer-reviewed journals on the subject of urban hydraulics it is clear that there are more articles on WDS than on UDS. Another probable reason is that drinking water supply infrastructure is considered strategic for a nation, in terms of its security against natural or anthropogenic disasters (i.e. terrorist attacks). However, lack of basic sanitation also has associated public health problems caused by contamination of natural water sources, particularly within large cities.

In developing countries, the lack of wastewater and rainwater collection and transport systems is often directly related to the cost of building such infrastructure. Faced with a shortage of financial resources, it is preferred to invest in other types of civil projects. The consequence is very frequent rainwater flooding, on the one hand, and an increase in diseases caused by the consumption of contaminated water, on the other. This is particularly serious in intermediate and small cities where, in addition, there is no easy access to high-level sanitary engineering. Therefore, it is necessary to

advance in the knowledge that allows reducing the costs of UWD networks, optimizing the financial resources for the construction processes.

7.2 About the Cost of Urban Water Infrastructure

In order to understand the magnitude of the difference in construction costs of the different networks that make up the urban hydraulic infrastructure, an example can be developed for the urban area of Bogotá, where the rainwater drainage network introduced as a new benchmark network in the articles that make up this doctoral thesis is located, the Chicó network, which corresponds to the neighborhood of the same name located in the northern part of the city of Bogotá (See Figure 7.1). The example shows the optimized design of the WDS and the two sewerage networks corresponding to rainwater and wastewater. The drinking water network was designed using the REDES program developed by the Centro de Investigaciones en Acueductos y Alcantarillados - CIACUA - of the Universidad de los Andes [1]-[2]. The two sewerage networks were designed following the methodology developed in this thesis.

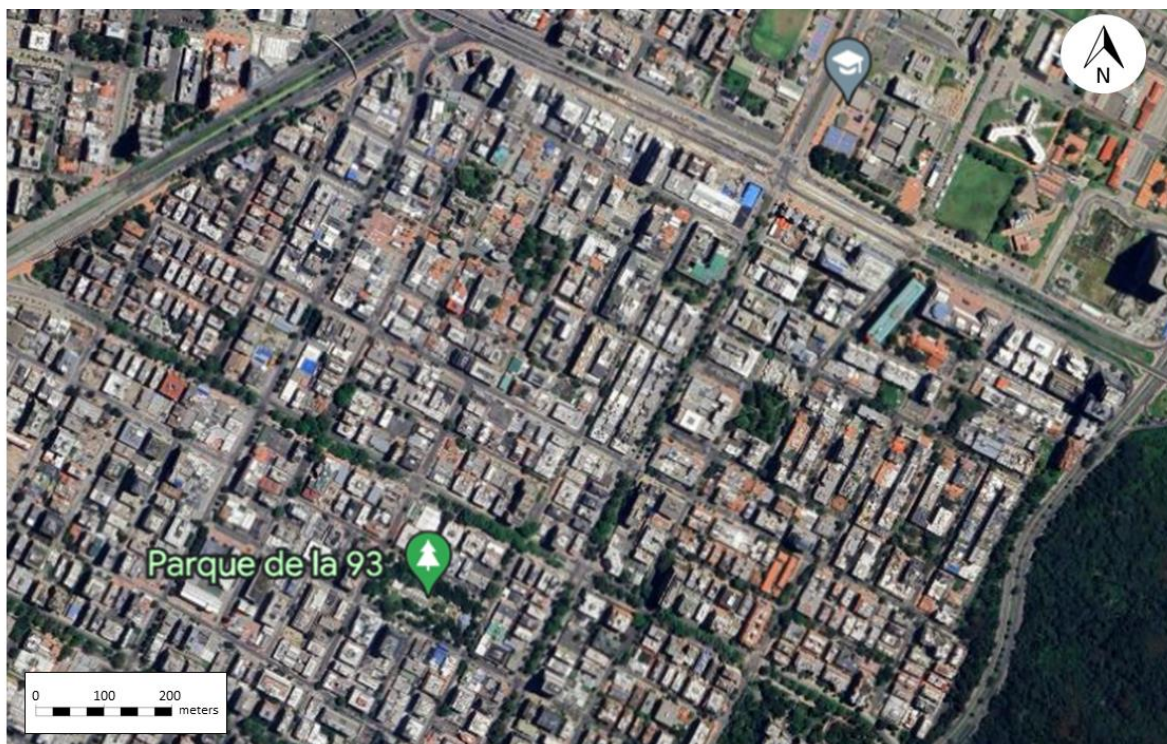

Figure 7.1. Satellite image of neighborhood Chicó located in the north of Bogotá.

drinking water network typically costs about 8.1% of the total cost of urban water infrastructure. These proportions remain relatively similar when using other cost equations reported in the scientific literature. Of course, if non-optimized designs are used in drainage networks, the above ratio could be reduced by as much as half. This explains to a large extent the worldwide gap between drinking water and basic sanitation coverage, since the investment of public resources is much higher. This gap is even worse for rainwater systems.

7.3 About the New Constraints

The development of an optimal design methodology for sewer networks is more complex than in the case of water distribution networks due to the greater number of hydraulic, topographical and construction constraints. In terms of the former, two problems must be solved in a sewerage system in addition to the actual transport of rainwater and/or wastewater. On the one hand, it is always necessary to leave a free surface in the pipes, in order to allow the circulation of gases generated by the decomposition of organic matter and to avoid that, in the event of a failure, the water leaves the system and contaminates the nearby groundwater. This implies a filling ratio of less than 100%, reducing the area available for flow. On the other hand, the system must transport the sediments that enter the system, whether of organic origin in sanitary systems or of mixed origin in rainwater systems. Therefore, the system must be designed to be capable of self-cleaning, which requires minimum velocities and/or shear stresses and that the diameters resulting from the design process be such that the diameter of the outlet pipe of each manhole is greater than or at most equal to the diameter of the largest inlet pipe to that manhole.

With respect to the constraints imposed by the topography of the terrain, first of all there is the fact that the energy available to move the water is directly related to the difference in height between the first manhole, corresponding to an outlet-branch pipe, and the outlet manhole of the system. The flow must always be by gravity and at free surface. In addition, each inflow to the system has its own level, so that the specific power input to each manhole is a fixed value, so there is little hydraulic flexibility, even more so because the network must be a tree, without any circuits. Therefore, the optimal topology or tree is given by this distribution of unitary powers, an aspect that should be part of the general process of optimized design.

Finally, the sewer design problem is also subject to constructive constraints. The main one is related to excavation depths. On the one hand, the standards require a minimum depth at top elevation for each pipe, in order to protect them from heavy loads caused mainly by vehicular traffic. On the other hand, the maximum depth at top elevation of each pipe is restricted, for reasons of cost and safety in excavations. This restricts the design solution space, making it more complex. However, it was shown that it was possible to solve the minimum cost design problem, while strictly complying with the constraints imposed by the regulations of each city.

7.4 About the Proposed Methodology

7.4.1 Hydraulic Design

After carrying out rigorous bibliographic research, establishing the state of the art of the optimized design of sewerage networks, it was found that different heuristics were used that, although they led to a really low cost, they did not ensure that the global minimum cost was reached. It was also found that in almost all cases the system tree was one of the input data. For this reason, the methodology was initially developed for a simple case: a series of sewer pipes, each following the other. In this case, each manhole has only one inlet and one outlet pipe, except for the first manhole which has only one outlet pipe and the last manhole, corresponding to the outfall, has only one inlet pipe. It was found that the design problem can be solved using the shortest path algorithm Bellman-Ford, widely documented in the literature related to optimization processes [6]. The problem leads to the global minimum cost design, respecting all hydraulic, topographic, and constructive constraints. However, it had the restriction that in each manhole, the inlet and outlet pipe invert elevations had to be the same, i.e., it was not possible to have drop manholes. This first design was called the Hydraulic Design (HD). The result included the diameter, filling ratio and slope of each pipe, as well as their inlet and outlet elevations, which corresponded to the bottom elevations of the manholes.

Once the series of pipes problem was solved, the next step was to solve the case of a sewer system with the known layout. The application of the shortest path algorithm could be easily applied by adding a new constraint: each manhole could have 1, 2 or maximum 3 inlet pipes, but only one outlet pipe. In addition, the invert elevation of the lowest inlet pipe had to match the invert elevation of the outlet pipe. The costs obtained were significantly lower than what was reported in the benchmark networks of the scientific literature. Again, it can be shown mathematically that this cost is the overall minimum.

7.4.2 Layout Selection (Tree-shaped structure)

The next logical step was to include the selection of the layout that would lead to the lowest cost. Using the program developed so far, it was possible to identify that different trees for the same urban layout led to different costs. For this reason, it was decided to include the selection of the layout within the design methodology. This problem was given the name of Layout Selection (LS). Initially, the problem was considered as an iterative one, which in a first iteration started from a random tree, to move on to the hydraulic design and with the results of this, using Mixed Integer Programming, improve the tree. The process was repeated until in two successive iterations the cost stopped improving, which occurred in a maximum of 30 iterations, having a high computational time, but improving even more the obtained cost. However, despite the reduction of costs obtained, in some cases the selected tree turned out to be strange. For example, in some of the sections it could choose a slope of the pipe in the opposite direction to the slope of the terrain in that section (counter slope).

To solve the above problem, it was decided to make use of the topography of the terrain and the location of each manhole (x,y,z coordinates) to select a first layout by initially using topographic criteria, such as the slope of the terrain in a section alone, the slope combined with the length of the section or the distance from the outlet manhole of the section to the outlet of the system. Subsequently, criteria were used based on the specific power of each inlet flow, understood as the product of that flow rate by the height with respect to the height of the outlet. The problem was established as a directed graph, in order to facilitate the application of the shortest path algorithm in

the HD. The results obtained were even lower costs and very few iterations, substantially reducing the computational time. However, the methodology cannot guarantee that the global minimum has been reached. This has not been mathematically proven. However, the results obtained lead to the lowest costs that have been reported in the literature.

The results, in addition to the global cost of the network, included the type of pipe of each section, which could be an outer-branch or an inner-branch pipe; the diameter, the filling ratio, and the slope of each section; the inlet and outlet elevation of each section; and the bottom elevation of each chamber. All the above for an absolute roughness of the pipes and complying with all the restrictions mentioned above. Figure 7.3 shown below, which corresponds to Figure 2.4, summarizes graphically the methodology developed.

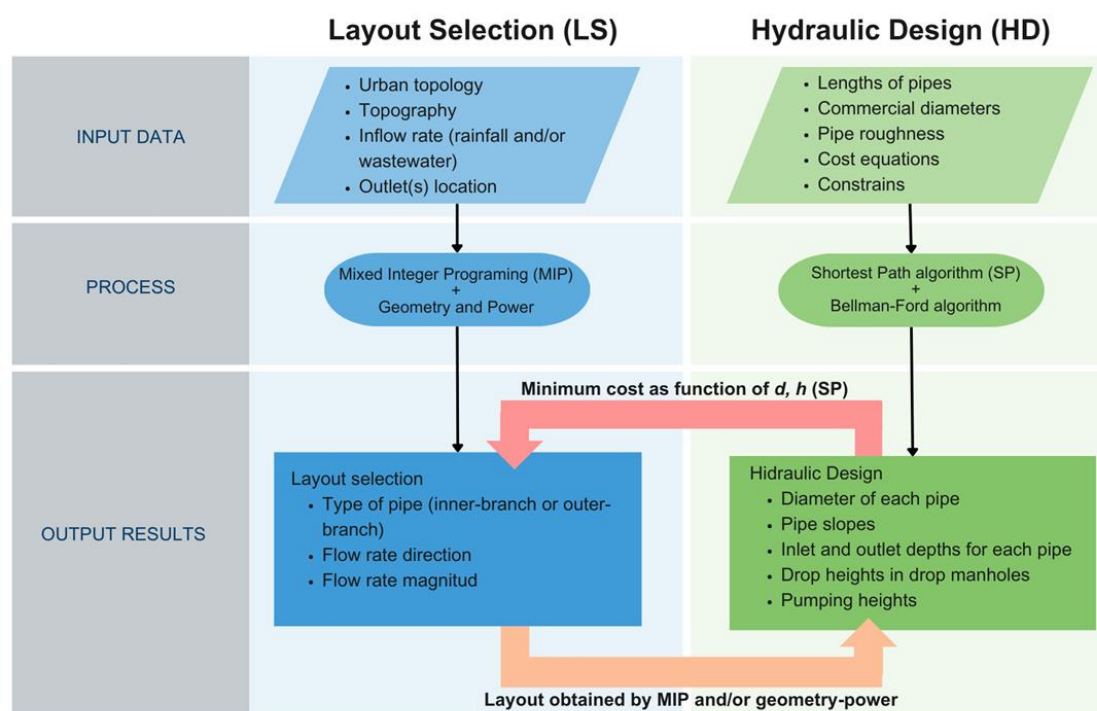

Figure 7.3. Flowchart methodology for sewer optimization.

7.5 About the Advantages of the Directed Graph Structure

As established in Chapter 3 of this doctoral thesis, in which the formal approach to LS and HD was established, the two problems are modeled using graph theory. Each uses a particular graph to represent the different aspects and structures that exist in an urban drainage network. The LS graph is connected to the HD graph through an auxiliary graph, the tree-structured graph, which converts the layout graph into an open network (Figure 7.4, which corresponds to Figure 3.1 in Chapter 3). The top graph represents the topology of the network and is based on the manholes, pipes, and outfall. The tree-structured graph (middle) is the representation of the layout as an open tree-like network in which nodes are added in order to represent all the manholes at the ends of the pipes (branches). Finally, the hydraulic design graph (bottom) is constructed following the same connectivity of the tree-structured graph to generate a set of design nodes for each tree-node in the middle graph, which at the same time belong to a manhole in the top graph.

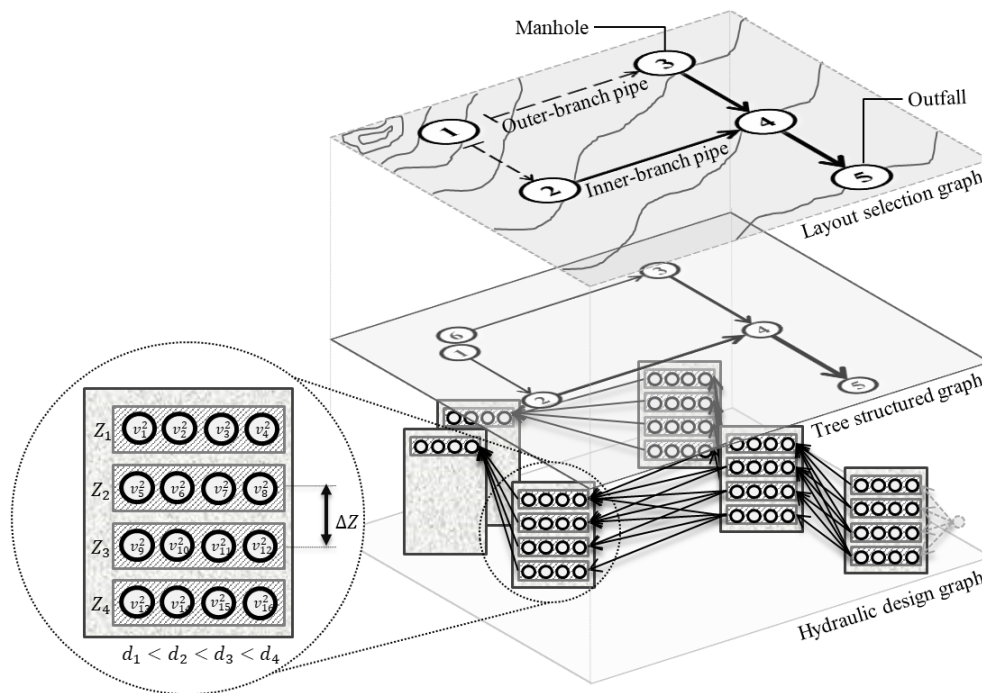

Figure 7.4. Relationship of the three sewer network design problem graphs. The layout selection graph (top) represents the network topology. Retrieved from: Duque et al. 2020.

For a sewer network, consisting only of manholes and pipes, outer-branch or inner-branch, the graph design nodes are used to establish the position and all pipe dimensions. Consequently, there are as many design nodes in each manhole as there are combinations of available pipe diameters and inlet and outlet invert elevations of the manhole. The possible invert elevations start at the minimum excavation limit and decrease according to a fixed change in elevation (ΔZ), until the maximum excavation limit is reached. The relationship between the three graphs was explained in detail in Chapter 3 in conjunction with the mathematical formulation of the optimization framework.

The structure of the three interacting graphs allows the developed design methodology to be easily used to include other structures typical of an urban sewer system, such as drop manholes, in-line pumping stations, combined sewer overflows, etc. This is achieved by using the nodes of the tree-structured graph and giving them the corresponding attributes of the new structures. These attributes not only describe the geometrical and topographical characteristics but also the structure of the corresponding cost equation. Thus, the new structures become an integral part of the optimization process. For example, if the drainage system is located in a hilly region, each of the nodes may or may not be a drop manhole; taking into account the construction costs of these structures, the methodology will give those nodes that should be drop manholes and their drop height so that the design is the minimum cost design. This was what was described in Chapter 3. Including an in-line pumping station follows a similar rationing. Figure 7.5 shown below presents some of the structures that can be modeled in the mathematical structure of the optimization algorithm.

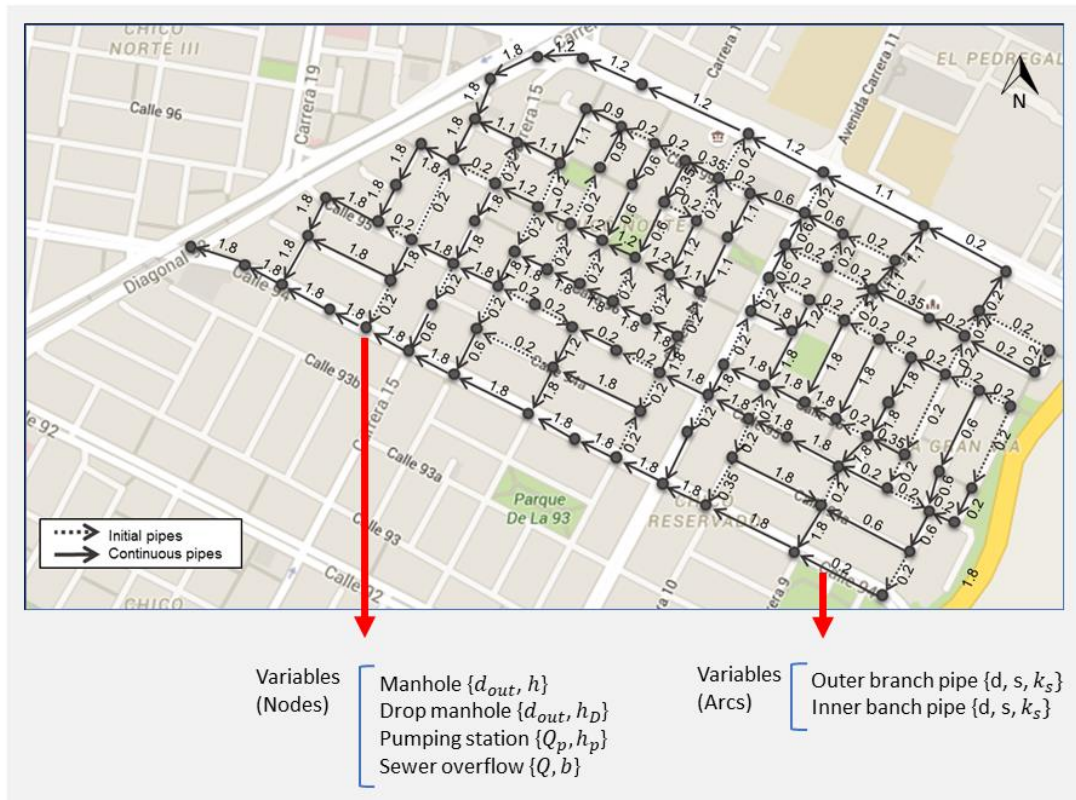

Figure 7.5. Different node types and attributes for the Hydraulic Design graph.

Figure 7.5 shows some of the possible node types and their attributes: manholes with outlet diameter and level; drop manholes with outlet diameter and drop height; in-line pumping station with pumping discharge and height; combined sewer overflow with alleviated discharge and weir width. The graph method proposed as part of the methodology can include many other node types. Arc attributes include pipe diameter, slope, and absolute roughness.

Figure 7.6 shows the representation of a drop manhole and an in-line pumping station within the hydraulic design graph, which are represented as a node in the tree-structured graph. Part (a) of the figure shows that a drop manhole is composed of two nodes representing the inlet (v_i^k) and outlet (v_j^k) pipes with their respective invert elevations and an arc representing the drop height $C_2(v_i^k, v_j^k)$. Part (b) shows that an in-line pumping station is composed of two nodes, the first one (v_i^k) (upstream) represents the diameter and the invert elevation of the inlet pipe, and the second one (v_j^k) (downstream) the invert elevation and the diameter of the outlet pipe. The arc (link) represents the pumping head $C_3(v_i^k, v_j^k)$. The notation shown in the figure corresponds to that of the mathematical model described in Chapter 3.

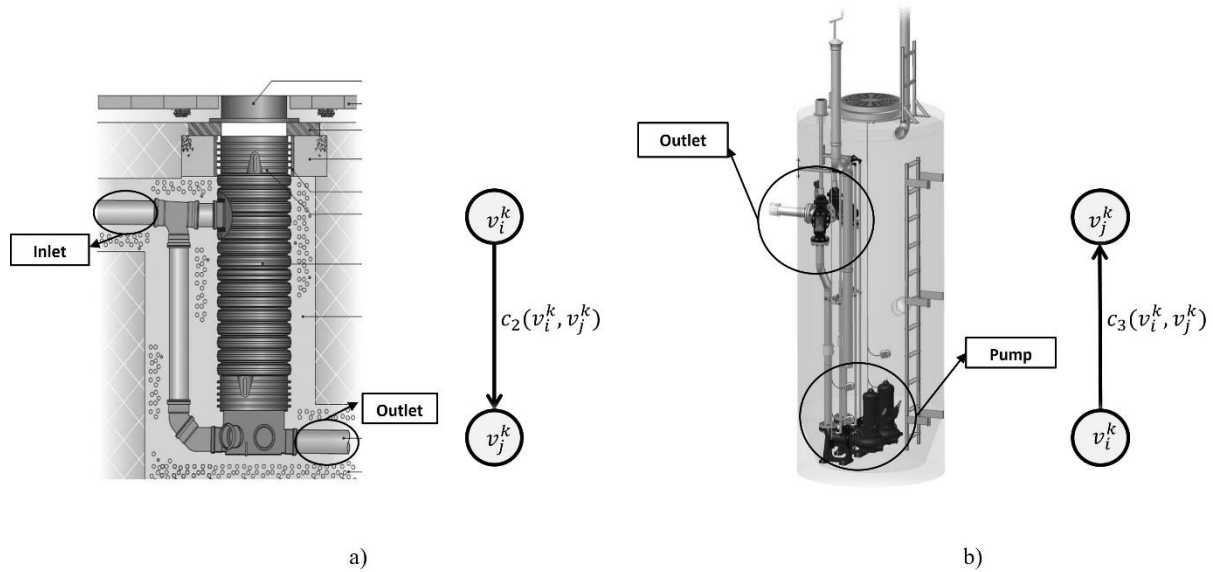

Figure 7.6. Representation of two structures in urban drainage systems within the Hydraulic Design (HD) graph. (a) Drop manhole represented by two nodes, one for the inlet pipe (higher) and the other for the outlet pipe (lower), and a link to represent the drop height. (b) In-line pumping station represented by two nodes, one for the inlet pipe (lower) and the other for the outlet pipe (higher), and a link to represent the pumping head.

The optimization model developed in this thesis could be extended to other types of problems that will be part of more detailed designs or adaptations of existing infrastructure to improve the operation and environmental impacts caused by urban drainage. An example of the former is to include the absolute roughness of pipes as part of the optimal design process; in hilly terrain (hilly regions) it could be advantageous, from a cost point of view, to have rougher pipes in order to limit the depth of the fall chambers. Among the changes that could be introduced to existing infrastructure, is to create loops within the system, leaving the typical tree topology to one that includes loops in order to facilitate maintenance work. Or, in manholes that include in-line pumping stations, an intermediate outlet pipe could be provided that would operate only in case of pump failure; the pump manhole would be blocked to that intermediate outlet level, which would be connected to a pipe that would carry the flow to a nearby branch, thus generating an emergency circuit.

7.6 About the Results Obtained

7.6.1 General Results

A methodology was developed that allows the optimized minimum cost design of urban drainage networks, both for wastewater and rainwater, including the selection of the layout (LS) and the hydraulic design (HD). In the technical literature there was no methodology to do that task; however, nowadays there is a high backlog in basic sanitation coverage through conventional sanitary sewers, particularly in developing countries, on the one hand, and climate change is increasing the frequency of more intense and longer rainfall events increasing the occurrence of pluvial flooding in cities, on the other hand. One of the causes most frequently associated with these problems is the high cost of drainage infrastructure, 8 to 10 times more expensive than drinking water infrastructure in a city. This was the problem that was the subject of the development of the new methodology.

The methodology was tested on benchmark urban drainage networks reported in the scientific literature and in all cases lower costs were obtained, complying with all hydraulic, construction and material constraints. The methodology is intelligible and easily programmable; the input data are the same as those required by any sewer design program, including cost equations for excavations, construction, pipelines, drop manholes and pumping stations, which may be different in each country. The computational speed is not affected by either the cost equations or the region-specific design constraints. The computational time to obtain a particular design does not exceed 10 minutes for large networks (more than 400 pipes). This allows the designer to try different design alternatives without a high computational cost. For example, the design can be made with different materials and diameter sets, according to what is available in the city where the project will be developed, or different excavation depths and different pipe coatings could be tested.

7.6.2 Design Constraints

One of the advantages of having an optimized design program that is fast and requires little computational effort in terms of processor and RAM size, is that you can easily test different alternatives and perform a sensitivity analysis to the constraints that the practice of sanitary engineering has imposed on the design of urban drainage systems. Of course, the stricter the design constraints, the more costly the resulting design will be. However, some of the constraints proved to have no effect on the designs.

One of them is the maximum filling ratio, on which there is a high variation in the technical regulations and standards of different countries. The less strict ones are characterized by allowing filling ratios of 85%, which corresponds to the maximum velocity for a given section, for wastewater sewers, and 93%, which corresponds to the maximum flow rate, for rainwater sewers. This was expected to reduce the costs of the sewer system, but the result of the optimal design shows that practically never results in a pipe with a filling ratio close to the maximum allowed. On the other hand, allowing such high filling ratios can lead to serious operational problems. Regulating the maximum fill ratio turned out to be innocuous.

The same applies to self-cleaning requirements. In general, technical regulations and standards in developing countries require minimum velocities and minimum shear stresses that are much lower (in some cases by as much as half) than those in developed countries. Again, the idea was to lower costs. However, the sensitivity of the design to these two parameters is again practically null. In optimized designs, where neither the tree nor the slope and diameter of each section are known in advance, the resulting velocities and shear stresses are much higher than these minimums. Now, in a non-optimized design allowing very low minimum velocities and/or shear forces can lead to costly and frequent operational problems.

It is also important to mention the minimum diameters required for a correct operation of the system. Typically, the minimum regulated diameters are 200 mm (8 inches) for sanitary systems and 250 mm (10 inches) for pluvial systems. In order to reduce costs, many developing countries are lowering these minimum diameters. Again, it was proven that this minimum diameter requirement has practically no effect on the total costs of an optimized system.

7.6.3 Sewer Systems in Hilly Regions

In Latin America, particularly in tropical countries, it is common to have major cities, as well as intermediate cities and small towns in mountainous areas. It is a group of countries characterized by having a large part of their population in Mediterranean cities, in the high mountains, far from the coasts. This is because the European conquerors found in these places more pleasant climatic conditions and less tropical diseases. This has led to urban drainage systems characterized by high slopes and consequently high flow velocities.

The way to solve this problem is to install the pipes with slopes lower than those of the ground, so that the maximum velocity remains within the norms established in technical regulations, usually 5 m/s and for plastic pipes 10 m/s. If the pipe has a slope less than that of the terrain, it should be installed with its maximum excavation depth at its initial point (upstream manhole); from that point on, the pipe approaches the surface of the terrain, always flowing with the maximum velocity. Once the minimum depth at top elevation has been reached, a drop manhole should be placed to deepen the pipe back to the maximum excavation depth. If the ground slope is very steep, then the pipe length will be shorter, so the distance between drop manholes decreases; this effect is more pronounced the less rough the pipe is. The total system cost is controlled by the cost of drop manholes, not by the cost of the pipes, and these drainage systems are significantly more expensive, per drained area, than in low slope terrain.

One of the ways to lower costs is to use rougher pipes. For a given maximum velocity, a rougher pipe will require a greater slope than a smooth pipe. Then, the distance between drop manholes increases and their number decreases substantially, lowering the costs of the drainage system. Of course, if the pipe is very rough, then it will require a larger diameter, thus increasing costs. This means that for a system in a hilly region there is an optimum roughness. This was tested with the help of the methodology developed in the doctoral thesis.

As mentioned above, the methodology developed results in which manholes there should be drop manholes and the corresponding drop height so that the overall cost of the system is the minimum, for each absolute pipe roughness and each terrain slope.

7.6.4 Sewer Systems in Flat Areas with Pumps

In very flat areas, as can often be the case in coastal areas, urban drainage systems are expensive because of their construction difficulty and because they usually require pumping stations. The long-term operating costs of these systems end up being extremely high because of the energy costs required for the pumps and now, because of the costs in tons of carbon equivalent. Therefore, an optimized design program must be very clear about the construction and installation costs of the in-line pumping stations, as well as the operating (mainly energy) and maintenance costs. The latter end up being much higher, even one or two orders of magnitude higher over the life of the project than the infrastructure investment costs. This implies that the optimized design methodology must now include operating costs.

The scheme developed in this doctoral thesis incorporated the possibility of having pumping stations for very flat terrain. In the methodology, any of the manholes can be an in-line pumping station. As a result, the program outputs which of the manholes should be pumping stations and what

the pumping head should be, so that total costs are minimized. A slight modification to the algorithm was included so that the designer must choose in advance the manholes that are candidates for pumping stations as a subset of the total number of manholes. The reason for this is due to the fact that, for reasons of space, noise, access to electric power, some manholes may not have pumping stations.

In testing the program for these cases an interesting result was found. Optimal sewer networks choose to pump as far upstream as possible within the tree in order to keep the hydraulic gradient line close to the minimum excavation depth. Always try to avoid pumping in the lower pipes of the tree, close to the delivery. The reason is that it is preferable to pump up a lower flow rate (upstream) than a higher flow rate (downstream). The program never selects the manhole closest to the outlet as the site to place a pumping station.

7.6.5 Reliability and Resilience of Urban Drainage Systems

Finally, another of the results to be discussed from those found in this thesis is related to the reliability and resilience of a sewerage network and how these are affected by the optimized minimum cost design of an urban drainage network. Chapter 6 of this doctoral thesis introduced the concepts of reliability and resilience used for the analysis, chosen from a heterogeneous set of ways to define these indices.

In order to measure the reliability of the different designs of a sewer network, the index proposed by Haghghi and Bakhshipour was used [7]. This index attempts to measure the consequences of the clogging of a system pipe within the tree configuration of the network layout (LS). This has an important implication, namely, the index does not depend on the hydraulic design (HD). The index assumes that the impact of the clogged pipe increases with the increase in flow rate carried by the pipe. The reliability index of a pipe is defined according to the following equation:

$$R_i = 1 - Q_i/Q_{out} \quad (7.1)$$

Where R_i is the reliability of pipe i , Q_i is the flow rate of pipe i , and Q_{out} is the flow rate at the outlet of the drainage network (outfall). For the complete network, the reliability is calculated as the average of the reliabilities of all the pipes, as shown in the following equation:

$$ARI = 1 - \frac{\sum Q_i}{mQ_{out}} \quad (7.2)$$

Where ARI is the average reliability index, and m is the number of pipes in the network. For the present work, only the inner branch pipes were considered in the average calculation.

On the other hand, to measure resilience, in this doctoral thesis, the index proposed by Mugume et al. was used [8], adapted to conditions of permanent flow in the network, in which the duration of flooding caused by a storm in which its duration time is equal to the simulation time. This was done in order to use cases reported in the literature in which there was only a single inflow and not a hydrograph. Then, the resilience index is defined as:

$$RES_o = 1 - \frac{V_{TF}}{V_{TI}} \quad (7.3)$$

Where Res_o is the resilience index, V_{TF} is the total flood volume, and V_{TI} is the total inflow volume to the sewer system. As for the reliability index, the resilience index was calculated using only the inner branch pipes.

With the aforementioned indices, we proceeded to work with different designs of urban drainage networks, starting with the minimum cost one, calculating the two resulting indices as a function of both the layout selection (LS) and the hydraulic design (HD). We then proceeded to make other non-optimal designs of the same network, considered appropriate within a traditional design context, with different trees chosen again following traditional practice. What was found is that you can have low cost designs with high reliability/resilience and very expensive designs with very low reliability/resilience. Several optimized designs had relatively high reliabilities/resiliencies. This implies that the proposed methodology does not affect the reliability/resilience of a drainage network.

What would have an effect on both the reliability and resilience of a sewer network would be to introduce some circuits in the network, abandoning the idea of the open tree-type configuration that is always used in urban drainage. In particular, adding circuits in the case of networks with in-line pumping stations. In order to prevent flooding in case of failure of the pump(s), before the water level in the upstream pipes reaches the overload condition, the manhole of the pumping station should have a second pipe with an outlet above a certain level, so that the unpumped flow is sent to another nearby pipe, forming a circuit that would operate only in case of emergency. Something similar could be developed in areas of very low slope within an urban drainage system. And a final case is to have two outfalls, dividing the flows according to water levels in different manholes of the network.

8. Conclusions and Recommendations

Preamble

This last chapter aims to present the conclusions and recommendations of the doctoral thesis, as well as the publications made as part of it. Here, it is important to remember that the main objective was the development and implementation of a methodology that will allow the minimum cost design of a sewer network.

The sewer network design problem was divided into two subproblems: the layout selection and the hydraulic design. The layout selection establishes the tree-structure of the network, which is composed of different sized series of pipes and indicates the flow rate and flow direction in each pipe. On the other hand, the hydraulic design determines the diameter and the upstream and downstream elevation, and the slope of each pipe, given some restrictions on hydraulics, available commercial diameters, and construction. The two subproblems have been satisfactorily achieved, and together they allow to obtain a near optimal design of a sewer network. As results, four papers were published in ISI peer review journals, four papers were presented in international conferences and congresses, and three papers are in the process of revision in ISI peer review journals.

8.1 Conclusions

The conclusions presented below are divided according to the different specific objectives of the doctoral thesis. It is important to clarify that these are complementary and more general conclusions than those contained in the papers in Chapters 3 to 6.

8.1.1 Conclusions on General Methodology

- a) The methodology developed was based on dividing the optimal sewer network design into two subproblems: The layout (or tree) selection (LS) and the hydraulic design (HD). The process iterated between these two subproblems: initially, a random tree was selected, respecting the topology of streets and roads, and with this a hydraulic design was made. Based on this result, a linear regression was performed between the cost of each pipe and its design flow rate. The linear regression coefficients were used in the objective function of the layout selection, so that with each iteration this objective function would be closer to the real costs of the network. The process continued until in two successive iterations the costs were very close.
- b) The hydraulic design (HD) has as input data a given layout (initial or from a previous iteration), the x,y,z coordinates of each manhole, the design flow rates, the diameters and materials available, the coordinates of the outfall and the cost equation. With these, the problem was solved as a shortest path problem using the Bellman-Ford algorithm that, for the given layout, guarantees obtaining the minimum global cost. The developed algorithm allows the inclusion of any hydraulic constraint (minimum and maximum velocities, minimum shear stress, maximum filling ratio, etc.),

commercial constraint (commercial pipe diameters, existing materials, etc.), and constructive constraint (minimum and maximum excavation depths). The computational cost of the algorithm is low, taking about 360 seconds for a network of 150 pipes on a desktop computer with an INTEL Core i7 processor. However, the algorithm must perform about 30 iterations to converge, so that the total computational time is about 10,800 seconds for the mentioned network.

- c) The layout selection (LS) has as input data the topology of streets of the urban area to be designed, the topography of the terrain, the inflows per manhole, and the coordinates of the outfall. With an original random layout, a first hydraulic design (HD) is obtained that gives the costs of each pipe as a function of its diameter and excavation depth. With these costs, a cost equation is obtained per pipe, as a function of its flow rate and flow direction, and using a Mixed Integer Programming model, a new layout is produced, minimizing this cost function. This new layout is taken to the hydraulic design for a second iteration and so on. The Mixed Integer Programming algorithm is very fast, taking about 2 seconds for a network of approximately 150 pipes on a desktop computer with an INTEL Core i7 processor.
- d) Although the HD shortest path algorithm guarantees that the minimum global cost is obtained for a given layout and cost equation, combining it in the iterative process with the LS Mixed Integer Programming algorithm does not mathematically prove that the final cost obtained after 30 to 40 iterations is the global minimum cost. However, it is a cost that is close to that global minimum. This was proven in the designs of different sewer network benchmarks found in the literature.
- e) Of course, methodologies similar to the one developed in this doctoral thesis will help to meet Sustainable Development Goal No. 6 Water and Sanitation for All. This is particularly true for developing countries.

8.1.2 Conclusions on Hydraulic Design (HD)

- a) The graph used in the HD solution, making use of the Bellman-Ford algorithm, in which the nodes represent the possible combinations of diameters and invert elevations in the manholes and the arcs represent the diameter and upstream and downstream invert elevation for a specific pipe, makes it very simple to include other typical structures of a sewer network. As part of the development of this doctoral thesis, drop manholes and on-line pumping stations were included. In these cases, the design, for terrain with high slopes, includes the location of the drop manholes as a subset of the total system manholes, as well as the drop height, i.e., the difference between the invert elevation of the highest inlet pipe and the invert elevation of the outlet pipe. Similarly, for very flat terrain, the HD provides the location of the pumping stations as a subset of the total manholes in the system, as well as the pumping head, measured between the invert elevation of the lowest inlet pipe to the invert elevation of the outlet pipe.
- b) Due to the nature of the generated network, the computational time is practically not affected by including other structures in addition to the manholes. Each drop manhole or pumping station is simulated as a new arc and two nodes. However, the shortest path algorithm slightly increases its computational cost.

- c) For reasons of urban planning, geography and available space, there are generally restrictions on the placement of special structures in urban drainage systems. For example, a combined sewer overflow must be close to a receiving body, which limits the number of manholes in the total set that can be considered as possible overflow. Another example is the pumping station; not all manholes would be candidates for the location of this type of structure for reasons of space, available energy or noise, among other aspects. Something similar happens with drop manholes and other complementary structures. In a very simple way, the HD shortest path algorithm can be adapted to include these new constraints. This was done as part of the doctoral thesis and tested on one of the benchmark networks.

8.1.3 Conclusions on Layout Selection (LS)

- a) The objective of layout selection, given an urban topology of streets and the location of the outfall, is to decide which of the pipes are inner-branch pipes and which are outer-branch pipes. However, the number of possible layouts is extremely high for typical urban drainage networks, growing exponentially with the number of manholes and pipes. For this reason, starting an optimized design process with a random layout result in a computationally expensive method. It is necessary to reduce the solution space by some heuristic or physical principle.
- b) A sewer network is a hydraulic system whose purpose is to transport flows from higher areas to a lower area, which is the outlet. The inflows enter all the manholes, characterized by different heights and distances with respect to that outfall. Therefore, the problem is of mass transport (volumes of water) and available specific power (flow rates by heights) along some lengths (distances to delivery). The specific power is which will be expended by the system to move the entire mass of water. A physical approach to reduce the solution space is to prioritize the pipes that must be inner-branch pipes based on the flow they must move and their available specific power, i.e., when deciding which pipe should be the outlet pipe of a manhole, choose the one that maximizes the mass moved and the specific power dissipated.
- c) In this doctoral thesis it was proven that using a physics-based approach to choose the first layout substantially decreases the exploration of the solution space. This first layout depends on the location and magnitude of each inflow to the drainage system and the heights and distances from each manhole to the outfall. The LS-HD iterative process based on this first layout proved to require very few iterations, solving the computational cost problem. In some of the tested networks this first layout led to a design closed to the minimum cost design in only one first iteration.
- d) The physical approach was based on three different criteria, proposed, and tested as part of this doctoral thesis. The first criterion seeks that the slopes of the pipes go in the same direction of the slope of the terrain in order to avoid large volumes of excavation. The second criterion also seeks that the pipes go in the same direction as the slope of the terrain and prioritizes the pipes with the largest available head to transport the flow. Finally, the third criterion seeks to minimize the length of the main series of the network in order to reduce the volume of excavation; this last criterion is designed for networks located in flat terrain. As part of future work, further research should be carried out on other criteria that use the specific power dissipated and not only the geometry of the problem.

8.1.4 Conclusions on Sewer Network Hydraulics

- a) In analyzing the results of the optimized design processes performed in this thesis, it was concluded that, for flat terrain, the lowest costs are achieved by using the smoothest material available in each case. A lower absolute roughness generates lower friction energy losses which translates into lower pipe slopes and, consequently, lower excavation volumes. Additionally, pipes with lower roughness tend to require smaller diameters for their design flow. A material with a high absolute roughness may require a larger diameter for a given flow rate and considering that once a diameter is reached, the construction restrictions establish that the downstream diameters have to be equal or larger than that, which can have a large impact on the total costs of that alternative.
- b) In very flat terrain, urban drainage systems require pumping in order to avoid excessive deepening of the pipes. The construction and, above all, operating costs of an on-line pumping station in a sewer system are extraordinarily high compared to the other costs. Therefore, in these cases, one should always opt for the smoothest pipes available on the local market. Additionally, the optimization process designed in this doctoral thesis showed that it is preferable, from a cost point of view, to place the pumping stations as far upstream as possible. This prevents the system from getting too deep by pumping lower flows at the beginning of the system. The algorithm tries to keep all sections as close to the surface as possible. It is a mistake to pump at the end of the drainage system.
- c) Pipes in steep terrain, such as those found in mountain towns, have slopes that are lower than those of the natural terrain, bringing them closer to the terrain's surface. A drop manhole must be installed once the pipe has reached its maximum allowable crown elevation, which is required to maintain a minimum depth from ground level to the crown of the pipe. Of course, this implies that an urban drainage system in a mountainous area is characterized by a large number of drop manholes, which is expensive. The algorithm tries to reduce the number of drop manholes by increasing the roughness of the pipes. This implies that very rough materials should be preferred in hilly terrain, but this has a limit because these materials would require larger diameters for a given design flow rate. As a result, the doctoral thesis proved that there is an optimum roughness for each mountain sewer system, with pipes of a very high absolute roughness. In the case of plastic materials, pipes with artificial roughness produced during the extrusion process are most likely required.
- d) The optimized minimum cost designs are not very sensitive to some of the design constraints set in the technical regulations and standards on design and construction of urban drainage systems. It was proven that establishing constraints at Froude numbers close to the critical flow has practically no effect on system costs. Likewise, it was found that for smooth materials, establishing a minimum shear stress higher than 2 or 3 Pascals has no effect on costs. Therefore, requiring higher minimum shear stresses guarantees a better operation of the system without increasing its costs appreciably. Finally, the optimized costs are not very sensitive to the chosen filling ratio, unless it is very low. There is practically no difference for maximum filling ratios varying between 70% and 90%.

8.1.5 Conclusions on Sewer Systems Resilience

- a) Cost is related to resilience in many infrastructure systems, including drinking water distribution networks that are part of urban water infrastructure, in such a way that there is a correspondence. This means that a lower-cost system has a lower level of resilience. A Pareto frontier can be constructed as part of a decision-making process to show the cost-resilience alternatives. Mugume et al. (2015)'s definition of resilience for a sewer network was used in the development of this doctoral thesis to study the relationship between cost and resilience in these types of systems. When attempting to construct the Pareto frontier, it was found that there is no a strong correlation between cost and resilience, which means that a low-cost sewer network can have high resilience. This is the alternative that should be pursued.

- b) It is clear that the number of outfalls in a sewer system correlates with its resilience. The more possible outfalls there are, the more independent trees there are, each moving total flows less than the total flow of a single tree, i.e. a single outfall. A greater number of trees means fewer urban flooding effects in stormwater systems or loss of service in sanitary systems in the event of a failure. However, multiple outfalls are not always possible due to urban planning and/or construction constraints.

8.1.6 General Conclusions

- a) Considering all previous conclusions, the main objective accomplished in this doctoral thesis is the development of a comprehensive and complete methodology for the optimal design of urban water drainage systems, to obtain the minimum construction cost fulfilling all technical, commercial and construction constrains. The developed methodology substantially reduces the level of subjectivity of the designer very common in urban hydraulics, particularly in the layout selection (LS) of sewer systems. The main objective of this thesis has been developed in three stages. The first stage was to develop an algorithm to obtain, given a particular layout, the optimal hydraulic design (HD). This algorithm is based in a Shortest Path Problem methodology using the Bellman-Ford algorithm that guaranties, for that layout and the corresponding cost equations, the minimum construction cost. The second stage developed a methodology for the selection of a layout that leads to a near global minimum cost. In this case a Mixed Integer Programming methodology was selected to work in an iterative way with the HD algorithm. In the third stage, some criteria based on the physics on water flow (mass, energy dissipation, specific power use) were added to the LS methodology achieving a high reduction in computational costs and approaching the solution to the global minimum.

- b) The developed methodology was applied to several benchmark sewer networks find in the technical literature. In all cases a new minimum cost was achieved, and in some cases the cost was much lower than the reported in the corresponding papers. Even in some of the reported cases the designs given as results do not always fulfill the corresponding constraints.

- c) In addition, in one of the benchmarks networks the layout was given. In this case, two tests were carried out, one in which the given layout was used and only the hydraulic design was optimized,

and the other in which both the layout and the hydraulic design were optimized with the proposed methodology. In both cases, lower cost designs were obtained compared with those previously proposed; however, the design in which the methodology was applied to the layout and hydraulic design obtained better costs.

- d) As part of the development of the new methodology in the doctoral thesis a new benchmark urban drainage system was introduced. It is based in a real stormwater that forms part of the general drainage system of Bogotá, Colombia. The Chico network has 109 manholes, 160 pipes, and one outfall with a total flow rate of 1.525 m³/s. The information regarding this network can be found in the following doi: 10.4121/8703d289-71d3-4009-928a-de77f8ecb091. In this you link will find information of the X, Y, and Z coordinates for each manhole in the network, and some parameters obtained in the optimized design of the network, such as, speed, shear stress, slope, among others.

8.2 Recommendations on Future Works

8.2.1 Further Developments

- a) The developed methodology must be extended to include other typical hydraulic structures that could be part of a particular urban drainage system. Pumps and drop manholes were already. Other structures include combined sewer overflows, energy dissipation structures, storm tanks. This will help to lower the costs of new urban developments but also, in the adaptation to climate change of existing urban drainage infrastructure.
- b) Regarding the resilience of sewer systems, it is important that a methodology for the minimal cost design could include the systematic analysis of several combinations of possible outfalls. Of course, that analysis must include the economic and environmental impacts of the receiving water body, either a natural water course or an artificial interceptor. Several outfalls, instead of just one, can lead to minor costs and higher resilience in a drainage system serving an urban area.
- c) It is highly recommended to apply the methodology developed in this doctoral thesis to the design of a real drainage system. Already, first contacts have been made with the Presidency of Colombia, through the Ministry of Housing, City and Territory (“Ministerio de Vivienda, Ciudad y Territorio” in Spanish), to help in the design of the sanitary sewer system in the city of Tumaco, in the pacific coast. This town is located in a very difficult terrain that makes a traditional design very costly.

8.2.2 General Recommendations

- a) The application of novel methodologies, based on heuristics and increasingly powerful and accessible computational tools, is nowadays possible in the case of urban hydraulic infrastructure. One of the problems that prevents their widespread use is caused by the fact that Sanitary Engineering, in general, is very traditional and always based on empirical knowledge that has been carried over to technical regulations, norms and standards still in force today. This is particularly true in developing countries where there is still a high deficit in the total coverage of basic sanitation service, and the cause is the high cost of infrastructure for communities with low economic resources. Therefore, access to tools that lead to optimized designs can help solve this problem, accompanied by new pipe material technologies and improved construction processes.

- b) In order for the processes of design optimization, operation and maintenance of urban drinking water, rainwater drainage and wastewater drainage infrastructure to be increasingly used, it is necessary that new technical regulations, technical norms and municipal and national standards require their use. The revision of such documents could be led by multilateral infrastructure financing agencies. In the past, entities such as the World Bank and the Inter-American Development Bank have encouraged and financed the writing of these regulations in different countries. This is the case of Colombia.
- c) From the academic point of view, it is advisable to introduce basic courses in optimization heuristics in sanitary engineering, civil engineering and hydraulic engineering programs, and then develop advanced undergraduate and graduate courses based on this basic knowledge. This would facilitate the application of new methodologies that will help future engineers to face such complex problems as water scarcity in many countries of the world and excess water in others, exacerbated by climate change.

8.3 Publications Resulting from this Doctoral Thesis

As a result of the research carried out in this doctoral thesis, the following scientific publications have been produced.

8.3.1 Scientific Papers

- 2023 *“Optimal Sewer Network Design for Cities in Hilly Regions”*. Juan Saldarriaga, Juana Herrán, Pedro L. Iglesias-Rey. *Urban Water Journal*. Received: 26 December 2022 / Accepted: 21 June 2023 / Published: 30 June 2023. DOI: 10.1080/1573062X.2023.2229303. ISI Periodical.
- 2023 *“Sewer Network Design Methodology for Low-cost, Resilient, and reliable designs”*. Juan Saldarriaga, Juana Herrán. *Urban Water Journal*. Received: 31 October 2022 / Accepted: 11 May 2023 / Published: 31 May 2023. DOI: 10.1080/1573062X.2023.2218339. ISI Periodical.
- 2021 *“Layout Selection for an Optimal Sewer Network Design Based on Land Topography, Streets Network Topology, and Inflows”*. Juan Saldarriaga, Jesús Zambrano, Juana Herrán, Pedro Iglesias. *Water* 2021, 13, 2491; Received: 2 August 2021 / Accepted: 8 September 2021 / Published: 10 September 2021. <https://doi.org/10.3390/w13182491> (registering DOI). ISI Periodical.
- 2020 *“Sewer Network Layout Selection and Hydraulic Design Using a Mathematical Optimization Framework”*. Natalia Duque, Daniel Duque, Andrés Aguilar, Juan Saldarriaga. *Water* 2020, 12 (12), 3337; Received: 13 October 2020 / Accepted: 20 November 2020 / Published: 27 November 2020. <https://doi.org/10.3390/w12123337> (registering DOI). ISI Periodical.

8.3.2 Papers in International Congresses and Conferences

- 2023 *“Comparación económica entre alcantarillado optimizado y condominial (Economic comparison between an optimized sewer system and a condominial system)”*. Sara Criollo, María A. González y Juan Saldarriaga. XVII Congreso Iberoamericano sobre Sistemas de Abastecimiento, Saneamiento y Riego. (SEREA23). 11 – 13 July 2023. Córdoba, España.
- 2023 *“Effect of pipe roughness in sewer networks design located hilly regions”*. Juan Saldarriaga, Sara Criollo, Santiago Acosta. 19th Computing and Control for the Water Industry Conference 2023. 4 – 7 September 2023. Leicester, United Kingdom.
- 2023 *“Fractal analysis in sewer network design”*. Juan Saldarriaga, Federico Weisner, Camilo Galindo. 19th Computing and Control for the Water Industry Conference 2023. 4 – 7 September 2023. Leicester, United Kingdom.
- 2023 *“Optimización de redes de alcantarillado: costos mínimos y confiabilidad máxima (Sewer networks optimization: minimum costs and maximum reliability)”*. Juana Herrán, Juan Saldarriaga. XVII Congreso Iberoamericano sobre Sistemas de Abastecimiento, Saneamiento y Riego. (SEREA23). 11 – 13 July 2023. Córdoba, España.
- 2022 *“Economic comparison between an optimized and a traditional sewer systems design”*. María Alejandra González, Juan Saldarriaga. II International Joint Conference on Water Distribution System Analysis & Computing and Control in the Water Industry WDSA CCWI 2022. Valencia, España.
- 2022 *“Optimal design of sewer networks including topographic criteria and drop manholes”*. Juan Saldarriaga, Juana Herrán, Pedro Iglesias. II International Joint Conference on Water Distribution System Analysis & Computing and Control in the Water Industry WDSA CCWI 2022. Valencia, España.
- 2021 *“A new approach for the optimal design of sewer networks including layout selection”*. Jesús Zambrano, María González, Juan Saldarriaga. The International Conference on Urban Drainage - ICUD2021. Virtual conference; 25 - 28 October 2021. University of Melbourne, Australia. IWA.

8.3.3 Scientific Papers Under Reviewing

- 2023 *“Optimal design of series of pipes in sewer systems including pumping stations for flat terrains”*. Juan Saldarriaga, Juana Herrán, Ana Acevedo, Pedro Iglesias. Sent to Urban Water Journal on July 26 of 2023.
- 2023 *“Analysis of the effect of pipe roughness in optimal sewer networks with drop manholes in steep terrains” (Preliminary title. Subject to revision)*. It will be sent to: Urban Water Journal or Journal of Hydraulic Research. Juan Saldarriaga, Santiago Acosta, Juana Herrán, María A. González, Pedro Iglesias. Pending to be send.

- 2023 *“Sewer network optimal design including in line pumping stations under Climate Change restrictions” (Preliminary title. Subject to revision).* It will be sent to: Journal of Hydroinformatics. Juan Saldarriaga, Brayan Yesid Coy, Federico Wiesner, Juana Herrán, Pedro Iglesias. Pending to be send.
- 2023 *“Fractal analysis of minimum cost design of sewer networks” (Preliminary title. Subject to revision).* It will be sent to: Urban Water Journal. Juan Saldarriaga, Camilo Galindo, Federico Wiesner, Pedro Iglesias. Pending to be send.

9. Future works

Preamble

The objective of this final chapter is to summarize future work, some of which is currently in development at the time of writing this doctoral thesis document, in which the methodology developed for the optimal design of sewer networks will be applied. First, the lines of work that have been identified and where some work has already been completed are described. Following that, the papers that have already been submitted to ISI journals and are in the normal peer review process are listed. Dissemination plans are also discussed in order to make known the possibilities of applying what has been investigated, both in international congresses and in continuing education courses and thematic conferences.

9.1 Lines of Work

The methodology for optimal design of sewer networks was created with the idea that any other type of structure that is part of this infrastructure could be easily added. As a result, a first line of work is to incorporate combined sewer overflows, on-line pumping stations, energy dissipation structures, and temporary storage (storm tanks) as new network elements, i.e. new nodes and arcs, into the optimization process for both LS and HD. For this it will be necessary to discover or develop new cost equations that describe the new structures, including construction and operating costs.

A second line of work is to use the computational tool developed for the optimal design to better understand the hydraulic relationships between pipe roughness and terrain slope. This relationship seems to indicate that, for networks in very flat terrain, in order to reduce construction and operating costs of pumps and on-line pumping stations, the optimum is to use the smoothest pipes, i.e. those with the lowest absolute roughness, that are available on the market. However, this is different in hilly terrain where the use of rougher pipes may be better, from a cost point of view, because they dissipate a greater amount of energy requiring fewer drop manholes and/or shallower drop manholes. There appears to be an optimum roughness as a function of the average slope of the terrain on which the sewer system is to be installed.

The third identified line of work is related to understanding the relationship between a sewer network's resilience and its optimized minimum cost design. The results obtained appear to indicate that these criteria are not necessarily in conflict and that low-cost designs with high levels of resilience are possible. Furthermore, the feasibility of dividing a large network into two or more smaller networks, each with its own delivery point, should be investigated in a multi-objective optimization balancing the aggregate minimum cost of the subsystems and the overall resilience of the separate networks.

Finally, a longer-term line of work is to adapt the rainwater networks to the new flow rates that are being generated by climate change. In many cities of the world, particularly in tropical countries, this meteorological phenomenon is implying rainfall with greater intensities and durations, which means that the existing drainage infrastructure, designed for a different hydrology, does not have sufficient capacity. Adaptation processes may be aided by methodologies such as the one developed in this thesis.

9.2 Papers in Development

At the time of writing this thesis document, in addition to the four papers included in chapters 3 to 6, three other papers have already been submitted to ISI journals and are in their normal peer review process. A short description of the papers follows.

9.2.1 Optimal Design of Series of Pipes in Sewer Systems Including Pumping Stations for Flat Terrains

This paper describes how to include on-line pumping stations into the process of optimal sewer system design when the terrain has very low slopes and it is necessary to elevate the water to avoid a deep excavation of the pipes. The pumping stations are installed in some of the manholes of the network, which were chosen by the designer based on space and/or energy availability considerations. Pumping stations are represented in the graph of the developed methodology by a pair of nodes and a new arc representing the pumping head. Pumping stations are only included in a series of pipes in this first section, not in the entire tree. One of the most important findings was that the optimized design algorithm prefers to locate pumping as far upstream as possible because lower flows (flows from upstream manholes) are pumped this way, keeping the network as shallow as possible and avoiding pumping at the system's end.

The following is the abstract of the submitted paper: "The present paper proposes a methodology for the optimal design of series of sewer pipes including on-line pumping stations. It uses a Shortest Path Algorithm to select the optimal combination of pipe diameters and invert elevations, as well as the optimal features of pumping stations including number of pumps, location, and pumping head. The use of the Shortest Path Algorithm guarantees optimality in the designs, finding the design with the lowest cost that complies with all constraints. Additionally, the study analyses the effect of pipe roughness, inflow per manhole, and pipe length on the total cost of the system and pumping station features. The methodology was tested in series of 10 and 20 pipes. According to the findings, the power has the greatest impact on the pumping cost. As a result, contrary to common belief, it is desirable to locate pumping stations upstream of the series to reduce pumping costs".

This paper was submitted to the Urban Water Journal in July 2023. The authors are Juan Saldarriaga, Juana Herrán, Ana Acevedo, and Pedro L. Iglesias-Rey.

9.2.2 Analysis of the effect of pipe roughness in optimal sewer networks with drop manholes in steep terrains

In terrain with steep slopes, such as those found in hilly cities or regions, the pipes of a sewer system have slopes that are lower than those of the ground in order to comply with the maximum speed constraint. As a result, a pipe beginning at the maximum excavation depth (another design constraint) approaches the ground surface as it travels downstream. Once the pipe reaches the minimum excavation depth, a drop manhole must be installed, causing the next pipe to have a starting invert elevation equal to the maximum excavation depth. The maximum speed is reached at a lower slope in a smooth pipe with very low absolute roughness than in a rougher pipe. That means that a system with rougher pipes requires fewer drop manholes and/or lower drop heights in these structures. Because the construction cost of drop manholes is very high compared to pipes, a system with higher roughness has a lower cost. However, this has a limit because, if the roughness increases too much, the design under uniform flow for a section may require a larger diameter, which increases costs. This means that there is an optimum roughness for a particular slope of the terrain. This was demonstrated using the methodology developed for the optimal design of sewer networks. This is the objective of this second paper already submitted.

The abstract of the paper is: “The present work presents a study of the effect of the pipe roughness in the construction cost of sewer networks in steep terrains. For this purpose, a sensitivity analysis was performed, wherein a sewer network was designed with different pipe roughnesses and varying the terrain slope to simulate four distinct steep terrains. In addition, this study considers the effect of new pipes with very high roughnesses that have appeared on the market in recent years, evaluating their influence on sewer network design and construction cost in steep terrains. The sewer networks were designed using an existing methodology for optimal design that includes drop manholes if they are required to meet all the hydraulic constraints. The effect of pipe roughness was tested in two sewer networks from distinct sectors of Bogotá, Colombia”.

This paper was submitted to the Journal of Hydraulic Research in August 2023. The authors are Juan Saldarriaga, Santiago Acosta, Juana Herrán, María A. González, and Pedro L. Iglesias-Rey.

9.2.3 Optimal Sewer Network Design with Pumping Stations

This last paper describes the way in which on-line pumping stations were included in the case of complete networks, i.e. those that also choose their optimum layout. The methodology allows the designer to choose those manholes in which it is feasible, from a constructive and/or urbanistic point of view, to locate such stations. Again, in the graph of the developed methodology, the stations are represented by two nodes and an arc; the latter represents the pumping head. As was the case in series of pipes, the optimal design algorithm tends to locate on-line pumping stations in the complete networks as far upstream as possible. This reduces pumping costs because flow rates are lower.

The abstract of this last paper is: “The present work presents a methodology for the optimal design of sewer networks with pumping stations. To achieve this purpose, the sewer network was modelled as a directed graph composed of nodes that represent the combination of possible diameters and excavation depths and two types of arcs, one that represents the pipes and another

that represents the pumping stations, assuming that in any manhole could be installed a pumping station. To obtain the minimum-cost design, the Bellman-Ford algorithm was used, which guarantees optimality for a given layout. To select the layout of the network, a Mixed Integer Programming model that includes topography criteria was used, which has proven to have great performance in previous works. The methodology was tested on three sewer network benchmarks from the literature. In all the sewer benchmarks, the cost achieved in the present work was compared with the best costs reported in the literature”.

This paper was submitted to the Urban Water Journal in September 2023. The authors are Juan Saldarriaga, Brayan Coy, Juana Herrán, Federico Wiesner, and Pedro L. Iglesias-Rey.

9.3 Divuligation plans

As part of the future work of this doctoral thesis, its dissemination is considered very important, in order to begin to weigh in the optimization processes of urban drainage systems to help meet Sustainable Development Goal No. 6 "Ensure availability and sustainable management of water and sanitation for all". Of course, the first form of dissemination, after articles in scientific journals, is the participation and publication of articles in international conferences. It is planned to have active participation of the Center for Research in Aqueducts and Sewage CIACUA of the Universidad de los Andes, in the next three years, in the following conferences:

- Environmental and Water Resources Institute EWRI congress, de la American Society of Civil Engineers ASCE.
- Computer and Control for the Water Industry CCWI.
- Congreso Iberoamericano sobre Sistemas de Abastecimiento, Saneamiento y Riego: SEREA (Ibero-American Congress on Water Supply, Sanitation, and Irrigation Systems SEREA).
- Congreso Latinoamericano de Hidráulica de la International Association of Hydraulic Research IAHR-AIRH (Latin American Hydraulics Congress of the International Association of Hydraulic Research IAHR-AIRH).
- Seminario Nacional de Hidráulica, Colombia (National Hydraulics Seminar, Colombia).

The second form of dissemination will be the organization of Continuing Education courses in the Department of Civil and Environmental Engineering of the Universidad de los Andes. In October 2023, a Modern Design of Urban Drainage Systems course will be offered in collaboration with the Dutch sewer pipe manufacturer WAVIN. The course has already been conceived and developed. More than 500 students from Latin America are anticipated to enroll in the non-attendance course.

Another less efficient but more profound form of dissemination is the change of the content of one of the postgraduate courses (masters and doctorate) in the Department of Civil and Environmental Engineering of the Universidad de los Andes. The course on Sustainable Urban Drainage Management has already been changed to include the design methodology developed in this thesis and is being taught in the current academic semester (Semester 2023 II).

9.4 Collaboration with the Government of Colombia

As stated in the Preamble to Chapter 1, one of the primary motives for selecting this doctoral thesis topic was to help enhance the coverage of basic sanitation services in distant and impoverished parts of Colombia. The Plan "Todos Somos Pazcífico" of the Colombian Presidency, which is in charge of providing drinking water and basic sanitation to the cities along Colombia's Pacific Coast, which are marked by poverty and racial minorities, was approached for this reason. The largest city in this area is Tumaco, which lacks urban drainage infrastructure.

Tumaco is located in the southwest of Colombia, near the border with Ecuador, and has a humid tropical climate. It is the 27th most populated municipality in Colombia with an estimated 257,052 inhabitants as of 2020, 70% of whom live in the urban area. Most of the inhabitants are indigenous or Afro descendants. The city was developed at the mouth of several rivers on an alluvial estuary. The average altitude of the urban area is 2 meters above sea level and the tides of the Pacific on this coast exceed 5 meters between high tide and low tide. The city grew without any land-use planning or logical urban development. These conditions make the development of a sanitary drainage system technically complex and extremely costly. An optimized design would be of great help in providing an economically viable alternative.

The work agreed upon with the Republic's Presidency is to accompany the design of the municipality's sanitary sewer system. This must be completed within the next 12 months, beginning in October 2023.

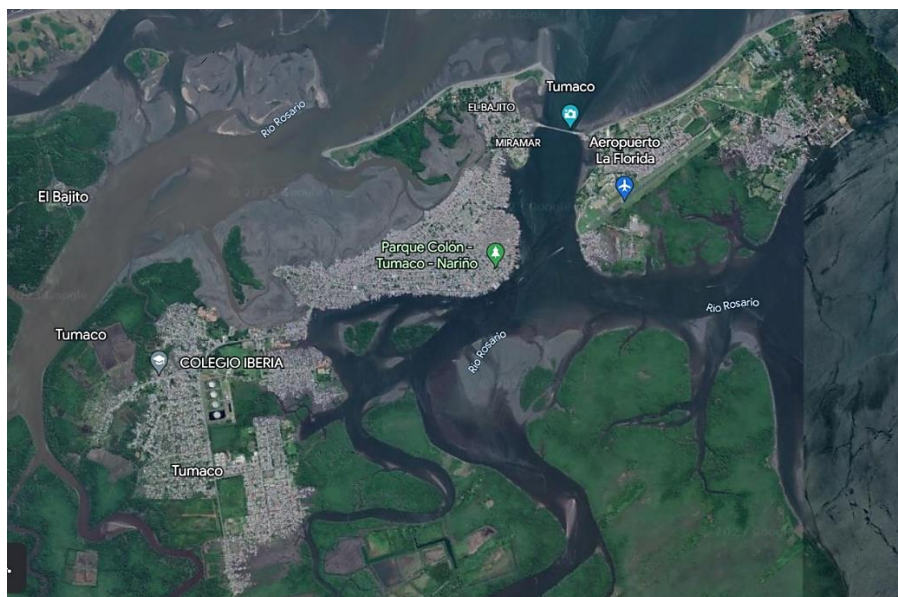

Figure 9.1. Aerial photograph of Tumaco

The image below depicts the high population density of Tumaco. The area shown corresponds to Tumaco Island, one of the three islands that make up the municipality.



Figure 9.2. Population density in Tumaco Island

Finally, a new revision of the Technical Regulation of the Drinking Water and Basic Sanitation Sector RAS is being planned by the Ministry of Housing, City and Territory (Ministerio de Vivienda, Ciudad y Territorio), which is the government of Colombia's agency responsible for this sector's technical regulation. The Universidad de los Andes will participate in this revision process. The new version will mandate that cost optimization and an analysis of the resilience of urban drainage systems to external factors like population growth and climate change be included in the design process.

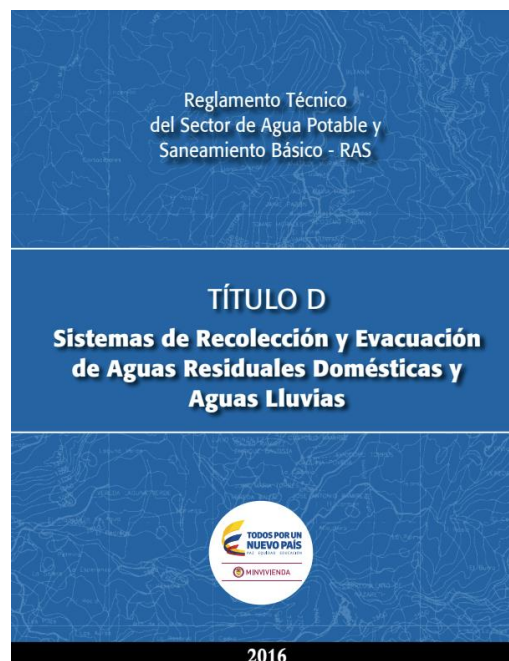

Figure 9.3. Technical Regulation of the Drinking Water and Basic Sanitation Sector RAS 2016

Appendix 1

References

A.1.1 References – Chapter 1

1. World Health Organization (WHO) Sanitation Available online: <https://www.who.int/es/news-room/fact-sheets/detail/sanitation> (accessed on 21 July 2023).
2. OECD Connection Rates to Wastewater Treatment Available online: https://stats.oecd.org/viewhtml.aspx?datasetcode=WATER_TREAT&lang=en (accessed on 21 September 2023).
3. Economic Commission for Latin America and the Caribbean (ECLAC) Basic Sanitation Available online: <https://www.cepal.org/es/temas/saneamiento-basico> (accessed on 2020).
4. WWAP (UNESCO World Water Assessment Programme). *The United Nations World Water Development Report 2019: Leaving No One Behind*; Paris, 2019; ISBN 978-92-3-100309-7.
5. WHO/UNICEF Data. WHO/UNICEF Joint Monitoring Programme for Water Supply, Sanitation and Hygiene (JMP). Available online: washdata.org/data.
6. DANE Basic Sanitation Coverage in Municipalities of Colombia Available online: <https://storymaps.arcgis.com/stories/22886ec822944d24a61065fae61ed4f4>.
7. Superintendencia de Servicios Públicos Domiciliarios. National Report on Coverage of Public Water, Sewage and Sanitation Services Available online: <https://www.superservicios.gov.co/sites/default/files/inline->.
8. Aradas, D., R.; Moreno, J.; Pinto, A.; Saldarriaga, J.G. Planificación Para La Preparación Del Plan Estratégico Sectorial de Drenaje Urbano Pluvial Para Colombia BID-INE/WSA. *Interamerican Development Bank* **2022**.
9. Grupo Consultor Costa *Consulting to Support the Development of the Urban Stormwater Management Policy in Colombia*; 2013;
10. Ramirez, L.; Arango, V.; Carrasquilla, A.; Sarmiento, A.; García, H.; Zea, R.; Ruíz, C.; Cabrera, C.; Mesa, D.; Restrepo, J.M.; et al. Documento CONPES 4004. **2020**.

A.1.2 References – Chapter 2

1. Cabral, M.; Loureiro, D.; Gomes, M.; Oliveira, R.; Covas, D. Statistical modelling of wastewater pumping stations costs. 1st International WDSA / CCWI 2018 Joint Conference, Kingston (Canada), July 2018.
2. Cayley, A. A Theorem on Trees. *Quarterly Journal of Mathematics* **1888**, *23*, 376–378, doi:<https://doi.org/10.1017/cbo9780511703799.010>.
3. Duque, N.; Duque, D.; Aguilar, A.; Saldarriaga, J. Sewer Network Layout Selection and Hydraulic Design Using a Mathematical Optimization Framework. *Water* **2020**, *12*, 3337, doi:<https://doi.org/10.3390/w12123337>.
4. Li, G.; Matthew, R.G.S. New Approach for Optimization of Urban Drainage Systems. *Journal of Environmental Engineering* **1990**, *116*, 927–944, doi:[https://doi.org/10.1061/\(asce\)0733-9372\(1990\)116:5\(927\)](https://doi.org/10.1061/(asce)0733-9372(1990)116:5(927)).
5. Maurer, M.; Wolfram, M.; Anja, H. Factors Affecting Economies of Scale in Combined Sewer Systems. *Water Science and Technology* **2010**, *62*, 36–41, doi:<https://doi.org/10.2166/wst.2010.241>.
6. Saldarriaga, J.; Herrán, J.; Iglesias-Rey, P.L. Optimal Sewer Network Design for Cities in Hilly Regions. *Urban Water Journal* **2023**, *20*, 1–11, doi:<https://doi.org/10.1080/1573062x.2023.2229303>. Saldarriaga, J.; Herrán, J.; Acevedo, A.; Iglesias-Rey, P. L. Optimal Design of Series of Pipes in Sewer Systems Including Pumping Stations for Flat Terrains. *Urban Water Journal* 2023 (submitted).

A.1.3 References – Chapter 3

1. Elimam, A.A.; Charalambous, C.; Ghobrial, F.H. Optimum design of large sewer networks. *J. Environ. Eng.* **1989**, *115*, 1171–1190, doi:10.1061/(asce)0733-9372(1989)115:6(1171).
2. Swamee, P.K.; Sharma, A.K. Optimal design of a sewer line using linear programming. *Appl. Math. Model.* **2013**, *37*, 4430–4439, doi:10.1016/j.apm.2012.09.041.
3. Gupta, M., Rao, P. and Jayakumar, K. Optimization of integrated sewerage system by using simplex method. *VFSTR J. STEM*, **2017**, *3*, 2455–2062,
4. Safavi, H.; Geranmehr, M.A. Optimization of sewer networks using the mixed-integer linear programming. *Urban Water, J.* **2017**, *14*, 452–459, doi:10.1080/1573062x.2016.1176222.
5. Holland, M.E. Computer models of waste-water collection systems. PhD Thesis, Harvard University, Cambridge, MA, USA, May **1966**
6. Mansouri, M.; Khanjani, M. Optimization of sewer networks using nonlinear programming. *J. Water Wastewater.* **1999**, *10*, 20-30.
7. Mays, L.W.; Yen, B.C. Optimal cost design of branched sewer systems. *Water Resour. Res.* **1975**, *11*, 37–47, doi:10.1029/wr011i001p00037.
8. Walters, G.A. The design of the optimal layout for a sewer network. *Eng. Optim.* **1985**, *9*, 37–50, doi:10.1080/03052158508902500.
9. Duque, N.; Duque, D.; Saldarriaga, J. A new methodology for the optimal design of series of pipes in sewer systems. *J. Hydroinformatics* **2016**, *18*, 757–772, doi:10.2166/hydro.2016.105.
10. Kulkarni, V.S.; Khanna, P. Pumped wastewater collection systems optimization. *J. Environ. Eng.* **1985**, *111*, 589–601, doi:10.1061/(asce)0733-9372(1985)111:5(589).
11. Afshar, M.H. Rebirthing genetic algorithm for storm sewer network design. *Sci. Iran.* **2012**, *19*, 11–19, doi:10.1016/j.scient.2011.12.005.
12. Haghghi, A.; Bakhshipour, A.E. Optimization of sewer networks using an adaptive genetic algorithm. *Water Resour. Manag.* **2012**, *26*, 3441–3456, doi:10.1007/s11269-012-0084-3.
13. Palumbo, A.; Cimorelli, L.; Covelli, C.; Cozzolino, L.; Mucherino, C.; Pianese, D. Optimal design of urban drainage networks. *Civ. Eng. Environ. Syst.* **2014**, *31*, 79–96, doi:10.1080/10286608.2013.820277.
14. Cozzolino, L.; Cimorelli, L.; Covelli, C.; Mucherino, C.; Pianese, D. An innovative approach for drainage network sizing. *Water* **2015**, *7*, 546–567, doi:10.3390/w7020546. Cisty, M. Hybrid genetic algorithm and linear programming method for least-cost design of water distribution systems. *Water Resour. Manag.* **2010**, *24*, 1–24, doi:10.1007/s11269-009-9434-1.
15. Cisty, M. Hybrid genetic algorithm and linear programming method for least-cost design of water distribution systems. *Water Resour. Manag.* **2010**, *24*, 1–24, doi:10.1007/s11269-009-9434-1.
16. Hassan, W.H.; Jassem, M.H.; Mohammed, S.S. A GA-HP model for the optimal design of sewer networks. *Water Resour. Manag.* **2018**, *32*, 865–879, doi:10.1007/s11269-017-1843-y.
17. Afshar, M.H. A parameter free continuous ant colony optimization algorithm for the optimal design of storm sewer networks: constrained and unconstrained approach. *Adv. Eng. Softw.* **2010**, *41*, 188–195, doi:10.1016/j.advengsoft.2009.09.009.
18. Moeini, R.; Afshar, M.H. Arc based ant colony optimization algorithm for optimal design of gravitational sewer networks. *Ain Shams Eng. J.* **2017**, *8*, 207–223, doi:10.1016/j.asej.2016.03.003.
19. Yeh, S.F.; Chang, Y.J.; Lin, M.D. Optimal design of sewer network by tabu search and simulated annealing. In Proceedings of the 2013 IEEE International Conference on Industrial Engineering and Engineering Management; Institute of Electrical and Electronics Engineers (IEEE), **2013**; 1636–1640.
20. Haghghi, A.; Bakhshipour, A.E. Deterministic integrated optimization model for sewage collection networks using tabu search. *J. Water Resour. Plan. Manag.* **2015**, *141*, doi:10.1061/(asce)wr.1943-5452.0000435.
21. Ahmadi, A.; Zolfagharipour, M.A.; Nafisi, M. Development of a hybrid algorithm for the optimal design of sewer networks. *J. Water Resour. Plan. Manag.* **2018**, *144*, doi:10.1061/(asce)wr.1943-5452.0000942.
22. Afshar, M.; Zaheri, M.; Kim, J. Improving the efficiency of cellular automata for sewer network design optimization problems using adaptive refinement. *Procedia Eng.* **2016**, *154*, 1439–1447, doi:10.1016/j.proeng.2016.07.517.
23. Rohani, M. and Afshar, M.H. Optimal design of Sewer network using Cellular Automata. *SCIREA J. of Hydraulic Engineering*, **2016**, *1*, 1–17.

24. Zaheri, M.M.; Ghanbari, R.; Afshar, M.H. A two-phase simulation–optimization cellular automata method for sewer network design optimization. *Eng. Optim.* **2019**, *52*, 620–636, doi:10.1080/0305215x.2019.1598983.
25. Navin, P.K.; Mathur, Y.P.; Kumar, D. Layout optimization of sewer network using minimum cumulative flow in the sewer network. In *Advances in Waste Management*; Springer Science and Business Media LLC, **2018**; 333–343.
26. Hsie, M.; Wu, M.Y.; Huang, C.Y. Optimal urban sewer layout design using Steiner tree problems. *Eng. Optim.* **2019**, *51*, 1980–1996, doi:10.1080/0305215x.2018.1560436.
27. Walters, G.A.; Smith, D.K. Evolutionary design algorithm for optimal layout of tree networks. *Eng. Optim.* **1995**, *24*, 261–281, doi:10.1080/03052159508941193.
28. Haghighi, A. Loop-by-loop cutting algorithm to generate layouts for urban drainage systems. *J. Water Resour. Plan. Manag.* **2013**, *139*, 693–703, doi:10.1061/(asce)wr.1943-5452.0000294.
29. Afshar, M.H.; Mariño, M.A. Application of an ant algorithm for layout optimization of tree networks. *Eng. Optim.* **2006**, *38*, 353–369, doi:10.1080/03052150600557783.
30. Moeini, R.; Afshar, M.H. Layout and size optimization of sanitary sewer network using intelligent ants. *Adv. Eng. Softw.* **2012**, *51*, 49–62, doi:10.1016/j.advengsoft.2012.05.003.
31. Moeini, R.; Afshar, M.H. Extension of the hybrid ant colony optimization algorithm for layout and size optimization of sewer networks. *J. Environ. Informatics* **2019**, *33*, 68–81, doi:10.3808/jei.201700369.
32. Navin, P.K.; Mathur, Y.P. Layout and component size optimization of sewer network using spanning tree and modified PSO algorithm. *Water Resour. Manag.* **2016**, *30*, 3627–3643, doi:10.1007/s11269-016-1378-7.
33. Mays, L.W.; Wenzel, H.G. Optimal design of multilevel branching sewer systems. *Water Resour. Res.* **1976**, *12*, 913–917, doi:10.1029/wr012i005p00913.
34. Li, G.; Matthew, R.G.S. New approach for optimization of urban drainage systems. *J. Environ. Eng.* **1990**, *116*, 927–944, doi:10.1061/(asce)0733-9372(1990)116:5(927).
35. Diogo, A.F.; Graveto, V.M. Optimal layout of sewer systems: A deterministic versus a stochastic model. *J. Hydraul. Eng.* **2006**, *132*, 927–943, doi:10.1061/(asce)0733-9429(2006)132:9(927).
36. Rohani, M.; Afshar, M.; Moeini, R. Layout and size optimization of sewer networks by hybridizing the GHCA model with heuristic algorithms. *Scientia Iranica. Transaction A, Scholarly Journals.* **2015**, *22*, 1742–1754.
37. Bakhshipour, A.E.; Makaremi, Y.; Dittmer, U. Multiobjective design of sewer networks. *J. of Hydraulic Structures.* **2017**, *3*, 49–56, doi:10.22055/jhs.2017.13316.
38. Nocedal, J.; Wright, S.J. *Numerical Optimization*, 2nd ed., Springer-Verlag: Berlin, New York, **2006**.
39. Smith, D.K.; Ahuja, R.K.; Magnanti, T.L.; Orlin, J.B. *Network Flows: Theory, Algorithms, and Applications.* *J. Oper. Res. Soc.* **1994**, *45*, 1340, doi:10.2307/2583863.
40. Butler, D.; Davies, J.W. *Urban Drainage*, Third Edition. Taylor & Francis: Abingdon, UK **2011**.
41. Bertsimas, D.; Tsitsiklis, J.N., *Introduction to linear optimization.* Athena Scientific, Belmont, MA, USA, **1997**, vol. 6, pp. 479–530.
42. Johnson, D. S.; Lenstra, J. K.; Kan, A. R. The complexity of the network design problem. *Networks.* **1978** *8*, 279–285, doi: 10.1002/net.3230080402.
43. Fair Isaac Corporation FICO. *Xpress-MP optimizer: Reference manual.* in FICO (ed.). Leamington Spa, release 20.0, FICO: UK **2009**, 19–23.
44. *Gurobi Optimizer*, 5.0. Available online: <http://www.gurobi.com>. (Accessed date: 08.06.2020).
45. Bellman, R. On a routing problem. *Quarterly of applied mathematics*, **1958**, *16*, 87–90.
46. Pan, T.C.; Kao, J.J. GA-QP Model to optimize sewer system design. *J. Environ. Eng.* **2009**, *135*, 17–24, doi:10.1061/(asce)0733-9372(2009)135:1(17).
47. Liu, C.; Han, H.G.; Wang, C.; Qiao, J. An adaptive differential evolution algorithm for sewer networks design. In *Proceeding of the 11th World Congress on Intelligent Control and Automation*; Institute of Electrical and Electronics Engineers (IEEE), **2014**; pp. 3577–3583.
48. Haghighi, A.; Bakhshipour, A.E. Reliability-based layout design of sewage collection systems in flat areas. *Urban Water, J.* **2016**, *13*, 790–802, doi:10.1080/1573062x.2015.1036085.

A.1.4 References – Chapter 4

1. Haghghi, A.; Bakhshipour, A. Reliability-based layout design of sewage collection systems in flat areas. *Urban Water J.* **2015**, *13*, 790–802, <https://doi.org/10.1080/1573062x.2015.1036085>.
2. Holland, M.E. Computer Models of Waste-Water Collection Systems. Ph.D. Thesis, Harvard University, Cambridge, MA, USA, May 1966.
3. Dajani, J.S.; Hasit, Y. Capital cost minimization of drainage networks. *J. Environ. Eng. Div.* **1974**, *100*, 325–337, <https://doi.org/10.1061/jeegav.0000163>.
4. Deininger, R.A. Computer aided design of waste collection and treatment systems. In Proceedings of the 2nd Annual Conference of American Water Resources, Chicago, IL, USA, 18 May 1966; pp. 247–258.
5. Elimam, A.A.; Charalambous, C.; Ghobrial, F.H. Optimum design of large sewer networks. *J. Environ. Eng.* **1989**, *115*, 1171–1190, [https://doi.org/10.1061/\(asce\)0733-9372\(1989\)115:6\(1171\)](https://doi.org/10.1061/(asce)0733-9372(1989)115:6(1171)).
6. Gupta, M.; Rao, P.; Jayakumar, K. Optimization of integrated sewerage system by using simplex method. *VFSTR J. Stem.* **2017**, *3*, 2455–2062.
7. Safavi, H.; Geranmehr, M.A. Optimization of sewer networks using the mixed-integer linear programming. *Urban Water J.* **2016**, *14*, 452–459, <https://doi.org/10.1080/1573062x.2016.1176222>.
8. Swamee, P.K.; Sharma, A.K. Optimal design of a sewer line using linear programming. *Appl. Math. Model.* **2013**, *37*, 4430–4439, <https://doi.org/10.1016/j.apm.2012.09.041>.
9. Mansouri, M.; Khanjani, M. Optimization of sewer networks using nonlinear programming. *J. Water Wastewater* **1999**, *10*, 20–30.
10. Price, R.K. Design of storm water sewers for minimum construction cost. In Proceedings of the 1st International Conference on Urban Storm Drainage, Southampton, UK, 1 January 1978; pp. 636–647.
11. Swamee, P.K. Design of Sewer Line. *J. Environ. Eng.* **2001**, *127*, 776–781, [https://doi.org/10.1061/\(asce\)0733-9372\(2001\)127:9\(776\)](https://doi.org/10.1061/(asce)0733-9372(2001)127:9(776)).
12. Gupta, A.; Mehndiratta, S.L.; Khanna, P. Gravity Wastewater Collection Systems Optimization. *J. Environ. Eng.* **1983**, *109*, 1195–1209, [https://doi.org/10.1061/\(asce\)0733-9372\(1983\)109:5\(1195\)](https://doi.org/10.1061/(asce)0733-9372(1983)109:5(1195)).
13. Kulkarni, V.S.; Khanna, P. Pumped Wastewater Collection Systems Optimization. *J. Environ. Eng.* **1985**, *111*, 589–601, [https://doi.org/10.1061/\(asce\)0733-9372\(1985\)111:5\(589\)](https://doi.org/10.1061/(asce)0733-9372(1985)111:5(589)).
14. Mays, L.W.; Yen, B.C. Optimal cost design of branched sewer systems. *Water Resour. Res.* **1975**, *11*, 37–47, <https://doi.org/10.1029/wr011i001p00037>.
15. Walters, G.A. The design of the optimal layout for a sewer network. *Eng. Optim.* **1985**, *9*, 37–50, <https://doi.org/10.1080/03052158508902500>.
16. Walters, G.A.; Templeman, A.B. Non-optimal dynamic programming algorithms in the design of minimum cost drainage systems. *Eng. Optim.* **1979**, *4*, 139–148, <https://doi.org/10.1080/03052157908902416>.
17. Duque, N.; Duque, D.; Saldarriaga, J. A new methodology for the optimal design of series of pipes in sewer systems. *J. Hydroinform.* **2016**, *18*, 757–772, <https://doi.org/10.2166/hydro.2016.105>.
18. Afshar, M.H. Rebirthing genetic algorithm for storm sewer network design. *Sci. Iran.* **2012**, *19*, 11–19, <https://doi.org/10.1016/j.scient.2011.12.005>.
19. Afshar, M.H.; Afshar, A.; Mariño, M.A.; Darbandi, A.A.S. Hydrograph-based storm sewer design optimization by genetic algorithm. *Can. J. Civ. Eng.* **2006**, *33*, 319–325, <https://doi.org/10.1139/I05-121>.
20. Haghghi, A.; Bakhshipour, A. Optimization of sewer networks using an adaptive genetic algorithm. *Water Resour. Manag.* **2012**, *26*, 3441–3456, <https://doi.org/10.1007/s11269-012-0084-3>.
21. Palumbo, A.; Cimorelli, L.; Covelli, C.; Cozzolino, L.; Mucherino, C.; Pianese, D. Optimal design of urban drainage networks. *Civ. Eng. Environ. Syst.* **2014**, *31*, 79–96, <https://doi.org/10.1080/10286608.2013.820277>.
22. Walters, G.A.; Lohbeck, T. Optimal layout of tree networks using genetic algorithms. *Eng. Optim.* **1993**, *22*, 27–48, <https://doi.org/10.1080/03052159308941324>.
23. Afshar, M. A parameter free continuous ant colony optimization algorithm for the optimal design of storm sewer networks: Constrained and unconstrained approach. *Adv. Eng. Softw.* **2010**, *41*, 188–195, <https://doi.org/10.1016/j.advengsoft.2009.09.009>.

24. Moeini, R.; Afshar, M.H. Layout and size optimization of sanitary sewer network using intelligent ants. *Adv. Eng. Softw.* **2012**, *51*, 49–62, <https://doi.org/10.1016/j.advengsoft.2012.05.003>.
25. Moeini, R.; Afshar, M. Arc based ant colony optimization algorithm for optimal design of gravitational sewer networks. *Ain Shams Eng. J.* **2017**, *8*, 207–223, <https://doi.org/10.1016/j.asej.2016.03.003>.
26. Ahmadi, A.; Zolfagharipour, M.A.; Nafisi, M. Development of a hybrid algorithm for the optimal design of sewer networks. *J. Water Resour. Plan. Manag.* **2018**, *144*, 4018045, [https://doi.org/10.1061/\(asce\)wr.1943-5452.0000942](https://doi.org/10.1061/(asce)wr.1943-5452.0000942).
27. Afshar, M.; Zaheri, M.; Kim, J. Improving the efficiency of cellular automata for sewer network design optimization problems using adaptive refinement. *Procedia Eng.* **2016**, *154*, 1439–1447, <https://doi.org/10.1016/j.proeng.2016.07.517>.
28. Haghghi, A.; Bakhshipour, A. Deterministic integrated optimization model for sewage collection networks using tabu search. *J. Water Resour. Plan. Manag.* **2015**, *141*, 4014045, [https://doi.org/10.1061/\(asce\)wr.1943-5452.0000435](https://doi.org/10.1061/(asce)wr.1943-5452.0000435).
29. Yeh, S.F.; Chang, Y.J.; Lin, M.D. Optimal design of sewer network by tabu search and simulated annealing. In *Proceedings of the 2013 IEEE International Conference on Industrial Engineering and Engineering Management, Bangkok, Thailand, 10–13 December 2013*; Institute of Electrical and Electronics Engineers (IEEE): Piscataway, NJ, USA, 2013; pp. 1636–1640.
30. Yeh, S.-F.; Chu, C.-W.; Chang, Y.-J.; Lin, M.-D. Applying tabu search and simulated annealing to the optimal design of sewer networks. *Eng. Optim.* **2011**, *43*, 159–174, <https://doi.org/10.1080/0305215x.2010.482989>.
31. Cisty, M. Hybrid genetic algorithm and linear programming method for least-cost design of water distribution systems. *Water Resour. Manag.* **2009**, *24*, 1–24, <https://doi.org/10.1007/s11269-009-9434-1>.
32. Pan, T.-C.; Kao, J.-J. GA-QP Model to Optimize Sewer System Design. *J. Environ. Eng.* **2009**, *135*, 17–24, [https://doi.org/10.1061/\(asce\)0733-9372\(2009\)135:1\(17\)](https://doi.org/10.1061/(asce)0733-9372(2009)135:1(17)).
33. Hassan, W.H.; Jassem, M.H.; Mohammed, S.S. A GA-HP Model for the Optimal Design of Sewer Networks. *Water Resour. Manag.* **2017**, *32*, 865–879, <https://doi.org/10.1007/s11269-017-1843-y>.
34. Li, G.; Matthew, R.G.S. New approach for optimization of urban drainage systems. *J. Environ. Eng.* **1990**, *116*, 927–944, [https://doi.org/10.1061/\(asce\)0733-9372\(1990\)116:5\(927\)](https://doi.org/10.1061/(asce)0733-9372(1990)116:5(927)).
35. Haghghi, A. Loop-by-Loop Cutting Algorithm to Generate Layouts for Urban Drainage Systems. *J. Water Resour. Plan. Manag.* **2013**, *139*, 693–703, [https://doi.org/10.1061/\(asce\)wr.1943-5452.0000294](https://doi.org/10.1061/(asce)wr.1943-5452.0000294).
36. Walters, G.A.; Smith, D.K. Evolutionary design algorithm for optimal layout of tree networks. *Eng. Optim.* **1995**, *24*, 261–281, <https://doi.org/10.1080/03052159508941193>.
37. Afshar, M.H.; Mariño, M.A. Application of an ant algorithm for layout optimization of tree networks. *Eng. Optim.* **2006**, *38*, 353–369, <https://doi.org/10.1080/03052150600557783>.
38. Bakhshipour, A.E.; Bakhshizadeh, M.; Dittmer, U.; Haghghi, A.; Nowak, W. Hanging gardens algorithm to generate decentralized layouts for the optimization of urban drainage systems. *J. Water Resour. Plan. Manag.* **2019**, *145*, 4019034, [https://doi.org/10.1061/\(asce\)wr.1943-5452.0001103](https://doi.org/10.1061/(asce)wr.1943-5452.0001103).
39. Bakhshipour, A.E.; Makaremi, Y.; Dittmer, U. Multiobjective design of sewer networks. *J. Hydraul. Struct.* **2017**, *3*, 49–56, <https://doi.org/10.22055/jhs.2017.13316>.
40. Diogo, A.F.; Graveto, V.M. Optimal layout of sewer systems: A deterministic versus a stochastic model. *J. Hydraul. Eng.* **2006**, *132*, 927–943, [https://doi.org/10.1061/\(asce\)0733-9429\(2006\)132:9\(927\)](https://doi.org/10.1061/(asce)0733-9429(2006)132:9(927)).
41. Rohani, M.; Afshar, M.; Moeini, R. Layout and size optimization of sewer networks by hybridizing the GHCA model with heuristic algorithms. *Sci. Iranica. Trans. A Sch. J.* **2015**, *22*, 1742–1754.
42. Steele, J.C.; Mahoney, K.; Karovic, O.; Mays, L.W. Heuristic optimization model for the optimal layout and pipe design of sewer systems. *Water Resour. Manag.* **2016**, *30*, 1605–1620, <https://doi.org/10.1007/s11269-015-1191-8>.
43. Bakhshipour, A.; Hespén, J.; Haghghi, A.; Dittmer, U.; Nowak, W. Integrating structural resilience in the design of urban drainage networks in flat areas using a simplified multi-objective optimization framework. *Water* **2021**, *13*, 269, <https://doi.org/10.3390/w13030269>.

44. Liu, Y.; Bralts, V.F.; Engel, B.A. Evaluating the effectiveness of management practices on hydrology and water quality at watershed scale with a rainfall-runoff model. *Sci. Total. Environ.* **2015**, *511*, 298–308, <https://doi.org/10.1016/j.scitotenv.2014.12.077>.
45. Duque, N.; Duque, D.; Aguilar, A.; Saldarriaga, J. Sewer network layout selection and hydraulic design using a mathematical optimization framework. *Water* **2020**, *12*, 3337, <https://doi.org/10.3390/w12123337>.
46. Moeini, R.; Afshar, M.H. Extension of the hybrid ant colony optimization algorithm for layout and size optimization of sewer networks. *J. Environ. Inform.* **2018**, <https://doi.org/10.3808/jei.201700369>.
47. Maurer, M.; Wolfram, M.; Anja, H. Factors affecting economies of scale in combined sewer systems. *Water Sci. Technol.* **2010**, *62*, 36–41, <https://doi.org/10.2166/wst.2010.241>.
48. Liu, C.; Han, H.G.; Wang, C.; Qiao, J. An adaptive differential evolution algorithm for sewer networks design. In *Proceedings of the 11th World Congress on Intelligent Control and Automation, Shenyang, China, 29 June–4 July 2014*; Institute of Electrical and Electronics Engineers (IEEE): Piscataway, NJ, USA, 2014; pp. 3577–3583.
49. United Nations (UN). Transforming Our World: The 2030 Agenda for Sustainable Development. Available online: <https://sustainabledevelopment.un.org/content/documents/21252030%20Agenda%20for%20Sustainable%20Development%20web.pdf> (accessed on 21 August 2017).

A.1.5 References – Chapter 5

1. Zheng, F.; Li, Y.; Zhao, J.; An, J. Energy Dissipation in Circular Drop Manholes under Different Outflow Conditions. *Water* **2017**, *9*, 752–752, doi:<https://doi.org/10.3390/w9100752>.
2. Christodoulou, G.C. Drop Manholes in Supercritical Pipelines. *Journal of Irrigation and Drainage Engineering-asce* **1991**, *117*, 37–47, doi:[https://doi.org/10.1061/\(asce\)0733-9437\(1991\)117:1\(37\)](https://doi.org/10.1061/(asce)0733-9437(1991)117:1(37)).
3. Granata, F.; Giovanni de Marinis; Gargano, R.; Hager, W.H. Hydraulics of Circular Drop Manholes. *Journal of Irrigation and Drainage Engineering-asce* **2011**, *137*, 102–111, doi:[https://doi.org/10.1061/\(asce\)ir.1943-4774.0000279](https://doi.org/10.1061/(asce)ir.1943-4774.0000279).
4. Carvalho, R.F.; Leandro, J. Hydraulic Characteristics of a Drop Square Manhole with a Downstream Control Gate. *Journal of Irrigation and Drainage Engineering-asce* **2012**, *138*, 569–576, doi:[https://doi.org/10.1061/\(asce\)ir.1943-4774.0000437](https://doi.org/10.1061/(asce)ir.1943-4774.0000437).
5. Crispino, G.; Pfister, M.; Corrado Gisonni Hydraulic Design Aspects for Supercritical Flow in Vortex Drop Shafts. *Urban Water Journal* **2019**, *16*, 225–234, doi:<https://doi.org/10.1080/1573062x.2019.1648531>.
6. Chanson, H. An Experimental Study of Roman Dropshaft Hydraulics. *Journal of Hydraulic Research* **2002**, *40*, 3–12, doi:<https://doi.org/10.1080/00221680209499868>.
7. Granata, F.; Gargano, R.; De Marinis, G.; Hager, W.H. Choking Features of Drop Manholes in Sewer Systems Available online: <https://www.iahr.org/library/infor?pid=10949> (accessed on 28 September 2023).
8. Granata, F.; de Marinis, G.; Gargano, R. Air-Water Flows in Circular Drop Manholes. *Urban Water Journal* **2014**, *12*, 477–487, doi:<https://doi.org/10.1080/1573062x.2014.881893>.
9. Steele, J.C.; Mahoney, K.; Karovic, O.; Mays, L.W. Heuristic Optimization Model for the Optimal Layout and Pipe Design of Sewer Systems. *Water Resources Management* **2016**, *30*, 1605–1620, doi:<https://doi.org/10.1007/s11269-015-1191-8>.
10. Moeini, R.; Afshar, M.H. Layout and Size Optimization of Sanitary Sewer Network Using Intelligent Ants. *Advances in Engineering Software* **2012**, *51*, 49–62, doi:<https://doi.org/10.1016/j.advengsoft.2012.05.003>.
11. Moeini, R.; Afshar, M.H. Arc Based Ant Colony Optimization Algorithm for Optimal Design of Gravitational Sewer Networks. *Ain Shams Engineering Journal* **2017**, *8*, 207–223, doi:<https://doi.org/10.1016/j.asej.2016.03.003>.
12. Navin, P.K.; Mathur, Y.P. Layout and Component Size Optimization of Sewer Network Using Spanning Tree and Modified PSO Algorithm. *Water Resources Management* **2016**, *30*, 3627–3643, doi:<https://doi.org/10.1007/s11269-016-1378-7>.
13. Alfaisal, F.M.; Mays, L.W. Optimization Models for Layout and Pipe Design for Storm Sewer Systems. *Water Resources Management* **2021**, *35*, 4841–4854, doi:<https://doi.org/10.1007/s11269-021-02958-5>.

14. Li, G.; Matthew, R.G.S. New Approach for Optimization of Urban Drainage Systems. *Journal of Environmental Engineering* **1990**, *116*, 927–944, doi:[https://doi.org/10.1061/\(asce\)0733-9372\(1990\)116:5\(927\)](https://doi.org/10.1061/(asce)0733-9372(1990)116:5(927)).
15. Haghghi, A.; Bakhshipour, A.E. Deterministic Integrated Optimization Model for Sewage Collection Networks Using Tabu Search. *Journal of Water Resources Planning and Management* **2015**, *141*, 04014045, doi:[https://doi.org/10.1061/\(asce\)wr.1943-5452.0000435](https://doi.org/10.1061/(asce)wr.1943-5452.0000435).
16. Duque, N.; Duque, D.; Aguilar, A.; Saldarriaga, J. Sewer Network Layout Selection and Hydraulic Design Using a Mathematical Optimization Framework. *Water* **2020**, *12*, 3337, doi:<https://doi.org/10.3390/w12123337>.
17. Saldarriaga, J.; Zambrano, J.; Herrán, J.; Iglesias-Rey, P.L. Layout Selection for an Optimal Sewer Network Design Based on Land Topography, Streets Network Topology, and Inflows. *Water* **2021**, *13*, 2491, doi:<https://doi.org/10.3390/w13182491>.
18. Duque, N.; Duque, D.; Saldarriaga, J. A New Methodology for the Optimal Design of Series of Pipes in Sewer Systems. *Journal of Hydroinformatics* **2016**, *18*, 757–772, doi:<https://doi.org/10.2166/hydro.2016.105>.
19. Maurer, M.; Wolfram, M.; Anja, H. Factors Affecting Economies of Scale in Combined Sewer Systems. *Water Science and Technology* **2010**, *62*, 36–41, doi:<https://doi.org/10.2166/wst.2010.241>.
20. Carvajal, J.; Zambrano, W.; Gómez, N.; Saldarriaga, J. Turbulent Flow in PVC Pipes in Water Distribution Systems. *Urban Water Journal* **2020**, *17*, 503–511, doi:<https://doi.org/10.1080/1573062x.2020.1786137>.
21. Saldarriaga, J.; Herran, J.; Iglesias-Rey, P.L. Optimal Design of Sewer Networks Including Topographic Criteria and Drop Manholes. In Proceedings of the 2 nd International Join Conference on Water Distribution System Analysis (WDSA) & Computing and Control in the Water Industry (CCWI); WDSA CCWI 2022: Valencia, Spain, 2022.

A.1.6 References – Chapter 6

1. Li, G.; Matthew, R.G.S. New Approach for Optimization of Urban Drainage Systems. *Journal of Environmental Engineering* **1990**, *116*, 927–944, doi:[https://doi.org/10.1061/\(asce\)0733-9372\(1990\)116:5\(927\)](https://doi.org/10.1061/(asce)0733-9372(1990)116:5(927)).
2. Moeini, R.; Afshar, M.H. Layout and Size Optimization of Sanitary Sewer Network Using Intelligent Ants. *Advances in Engineering Software* **2012**, *51*, 49–62, doi:<https://doi.org/10.1016/j.advengsoft.2012.05.003>.
3. Moeini, R.; Afshar, M.H. Arc Based Ant Colony Optimization Algorithm for Optimal Design of Gravitational Sewer Networks. *Ain Shams Engineering Journal* **2017**, *8*, 207–223, doi:<https://doi.org/10.1016/j.asej.2016.03.003>.
4. Moeini, R.; Afshar, M.H. Extension of the Hybrid Ant Colony Optimization Algorithm for Layout and Size Optimization of Sewer Networks. *Journal of Environmental Informatics* **2018**, *33*, doi:<https://doi.org/10.3808/jei.201700369>.
5. Haghghi, A.; Bakhshipour, A.E. Deterministic Integrated Optimization Model for Sewage Collection Networks Using Tabu Search. *Journal of Water Resources Planning and Management* **2015**, *141*, 04014045, doi:[https://doi.org/10.1061/\(asce\)wr.1943-5452.0000435](https://doi.org/10.1061/(asce)wr.1943-5452.0000435).
6. Duque, N.; Duque, D.; Aguilar, A.; Saldarriaga, J. Sewer Network Layout Selection and Hydraulic Design Using a Mathematical Optimization Framework. *Water* **2020**, *12*, 3337, doi:<https://doi.org/10.3390/w12123337>.
7. Saldarriaga, J.; Zambrano, J.; Herrán, J.; Iglesias-Rey, P.L. Layout Selection for an Optimal Sewer Network Design Based on Land Topography, Streets Network Topology, and Inflows. *Water* **2021**, *13*, 2491, doi:<https://doi.org/10.3390/w13182491>.
8. Diogo, A.F.; Graveto, V.M. Optimal Layout of Sewer Systems: A Deterministic versus a Stochastic Model. *Journal of Hydraulic Engineering* **2006**, *132*, 927–943, doi:[https://doi.org/10.1061/\(asce\)0733-9429\(2006\)132:9\(927\)](https://doi.org/10.1061/(asce)0733-9429(2006)132:9(927)).
9. Haghghi, A.; Bakhshipour, A.E. Optimization of Sewer Networks Using an Adaptive Genetic Algorithm. *Water Resources Management* **2012**, *26*, 3441–3456, doi:<https://doi.org/10.1007/s11269-012-0084-3>.
10. Navin, P.K.; Mathur, Y.P. Layout and Component Size Optimization of Sewer Network Using Spanning Tree and Modified PSO Algorithm. *Water Resources Management* **2016**, *30*, 3627–3643, doi:<https://doi.org/10.1007/s11269-016-1378-7>.

11. Steele, J.C.; Mahoney, K.; Karovic, O.; Mays, L.W. Heuristic Optimization Model for the Optimal Layout and Pipe Design of Sewer Systems. *Water Resources Management* **2016**, *30*, 1605–1620, doi:<https://doi.org/10.1007/s11269-015-1191-8>.
12. Alfaisal, F.M.; Mays, L.W. Optimization Models for Layout and Pipe Design for Storm Sewer Systems. *Water Resources Management* **2021**, *35*, 4841–4854, doi:<https://doi.org/10.1007/s11269-021-02958-5>.
13. Asefa, T.; Clayton, J.; Adams, A.; Anderson, D. Performance Evaluation of a Water Resources System under Varying Climatic Conditions: Reliability, Resilience, Vulnerability and Beyond. *Journal of Hydrology* **2014**, *508*, 53–65, doi:<https://doi.org/10.1016/j.jhydrol.2013.10.043>.
14. Sweetapple, C.; Fu, G.; Butler, D. Reliable, Robust, and Resilient System Design Framework with Application to Wastewater-Treatment Plant Control. *Journal of Environmental Engineering* **2017**, *143*, 04016086, doi:[https://doi.org/10.1061/\(asce\)ee.1943-7870.0001171](https://doi.org/10.1061/(asce)ee.1943-7870.0001171).
15. Butler, D.; Farmani, R.; Fu, G.; Ward, S.; Diao, K.; Astaraie-Imani, M. A New Approach to Urban Water Management: Safe and Sure. *Procedia Engineering* **2014**, *89*, 347–354, doi:<https://doi.org/10.1016/j.proeng.2014.11.198>.
16. National Infrastructure Advisory Council *Critical Infrastructure Resilience Final Report and Recommendations*; 2009;
17. Miszta-Kruk, K. Reliability and Failure Rate Analysis of Pressure, Vacuum and Gravity Sewer Systems Based on Operating Data. *Engineering Failure Analysis* **2016**, *61*, 37–45, doi:<https://doi.org/10.1016/j.engfailanal.2015.07.034>.
18. Tee, K.F.; Khan, L.R.; Chen, H.P.; Alani, A.M. Reliability Based Life Cycle Cost Optimization for Underground Pipeline Networks. *Tunnelling and Underground Space Technology* **2014**, *43*, 32–40, doi:<https://doi.org/10.1016/j.tust.2014.04.007>.
19. Haghighi, A.; Bakhshipour, A.E. Reliability-Based Layout Design of Sewage Collection Systems in Flat Areas. *Urban Water Journal* **2015**, *13*, 790–802, doi:<https://doi.org/10.1080/1573062x.2015.1036085>.
20. Kwon, S.H.; Jung, D.; Kim, J.H. Optimal Layout and Pipe Sizing of Urban Drainage Networks to Improve Robustness and Rapidity. *Journal of Water Resources Planning and Management* **2021**, *147*, 06021003, doi:[https://doi.org/10.1061/\(asce\)wr.1943-5452.0001350](https://doi.org/10.1061/(asce)wr.1943-5452.0001350).
21. Lee, E.H.; Lee, Y.S.; Joo, J.G.; Jung, D.; Kim, J.H. Investigating the Impact of Proactive Pump Operation and Capacity Expansion on Urban Drainage System Resilience. *Journal of Water Resources Planning and Management* **2017**, *143*, 04017024, doi:[https://doi.org/10.1061/\(asce\)wr.1943-5452.0000775](https://doi.org/10.1061/(asce)wr.1943-5452.0000775).
22. Lee, E.; Kim, J. Development of Resilience Index Based on Flooding Damage in Urban Areas. *Water* **2017**, *9*, 428, doi:<https://doi.org/10.3390/w9060428>.
23. Lee, E.H.; Choi, Y.H.; Kim, J.H. Real-Time Integrated Operation for Urban Streams with Centralized and Decentralized Reservoirs to Improve System Resilience. *Water* **2019**, *11*, 69, doi:<https://doi.org/10.3390/w11010069>.
24. Chen; Leandro A Conceptual Time-Varying Flood Resilience Index for Urban Areas: Munich City. *Water* **2019**, *11*, 830, doi:<https://doi.org/10.3390/w11040830>.
25. Mugume, S.N.; Gomez, D.E.; Fu, G.; Farmani, R.; Butler, D. A Global Analysis Approach for Investigating Structural Resilience in Urban Drainage Systems. *Water Research* **2015**, *81*, 15–26, doi:<https://doi.org/10.1016/j.watres.2015.05.030>.
26. Rossman, L.A. *Storm Water Management Model User's Manual Version 5.1 Office of Research and Development Water Supply and Water Resources Division*; 2015;
27. Maurer, M.; Wolfram, M.; Anja, H. Factors Affecting Economies of Scale in Combined Sewer Systems. *Water Science and Technology* **2010**, *62*, 36–41, doi:<https://doi.org/10.2166/wst.2010.241>.

A.1.7 References – Chapter 7

1. Saldarriaga, J.; Páez, D.; Salcedo, C.; Cuero, P.; López, L.L.; León, N.; Celeita, D. A Direct Approach for the Near-Optimal Design of Water Distribution Networks Based on Power Use. *Water* **2020**, *12*, 1037, doi:<https://doi.org/10.3390/w12041037>.
2. Saldarriaga, J.; Lopez, L. REDES: Programa de Simulación Hidráulica de Redes de Distribución de Agua Potable Para Uso Investigativo Y Académico. In Proceedings of the XII Simposio Iberoamericano sobre Sistemas de Abastecimiento de Agua y Drenaje Urbano (SEREA 2013); November 2013.

3. Fujiwara, O.; Khang, D.B. A Two-Phase Decomposition Method for Optimal Design of Looped Water Distribution Networks. *Water Resources Research* **1990**, *26*, 539–549, doi:<https://doi.org/10.1029/wr026i004p00539>.
4. Maurer, M.; Wolfram, M.; Anja, H. Factors Affecting Economies of Scale in Combined Sewer Systems. *Water Science and Technology* **2010**, *62*, 36–41, doi:<https://doi.org/10.2166/wst.2010.241>.
5. Li, G.; Matthew, R.G.S. New Approach for Optimization of Urban Drainage Systems. *Journal of Environmental Engineering* **1990**, *116*, 927–944, doi:[https://doi.org/10.1061/\(asce\)0733-9372\(1990\)116:5\(927\)](https://doi.org/10.1061/(asce)0733-9372(1990)116:5(927)).
6. Duque, N.; Duque, D.; Saldarriaga, J. A New Methodology for the Optimal Design of Series of Pipes in Sewer Systems. *Journal of Hydroinformatics* **2016**, *18*, 757–772, doi:<https://doi.org/10.2166/hydro.2016.105>.
7. Haghghi, A.; Bakhshipour, A.E. Reliability-Based Layout Design of Sewage Collection Systems in Flat Areas. *Urban Water Journal* **2015**, *13*, 790–802, doi:<https://doi.org/10.1080/1573062x.2015.1036085>.
8. Mugume, S.N.; Gomez, D.E.; Fu, G.; Farmani, R.; Butler, D. A Global Analysis Approach for Investigating Structural Resilience in Urban Drainage Systems. *Water Research* **2015**, *81*, 15–26, doi:<https://doi.org/10.1016/j.watres.2015.05.030>.

A.1. References – Appendix 2

1. Li, G., & Matthew, R. G. S. (1990). New Approach for Optimization of Urban Drainage Systems. *Journal of Environmental Engineering*, *116*(5), 927–944. [https://doi.org/10.1061/\(asce\)0733-9372\(1990\)116:5\(927\)](https://doi.org/10.1061/(asce)0733-9372(1990)116:5(927))

Figure A. 2 Topography of Chicó neighborhood.

Table A. 1 presents the hydraulic constraints used in the three designs that were proposed by Li and Mathew [1].

Table A. 1 Hydraulic constraints proposed by Li and Mathew (1990)

Constraint	Value	Condition
Minimum diameter	0.2 m	Always
	0.6	$d \leq 0.3$ m
Maximum filling ratio	0.7	$0.35 \text{ m} \leq d \leq 0.45 \text{ m}$
	0.75	$0.5 \text{ m} \leq d \leq 0.9 \text{ m}$
	0.8	$d \geq 1 \text{ m}$
Minimum velocity	0.7 m s^{-1}	$d \leq 0.5 \text{ m}$ and flow rate $> 0.015 \text{ m}^3 \text{ s}^{-1}$
	0.8 m s^{-1}	$d > 0.5 \text{ m}$ and flow rate $> 0.015 \text{ m}^3 \text{ s}^{-1}$
Maximum velocity	5 m s^{-1}	Always
Minimum gradient	0.003	Flow rate $< 0.015 \text{ m}^3 \text{ s}^{-1}$
Minimum depth	1 m	Always

Additionally, some other values that were used in this research were: a Manning's coefficient of $n = 0.014$ (concrete) to calculate the velocity using Manning's equation, and the list of diameter, in meters, used were $\{0.2, 0.25, 0.3, 0.35, 0.38, 0.4, 0.45, 0.5, 0.53, 0.6, 0.7, 0.8, 0.9, 1.0, 1.05, 1.20, 1.35, 1.40, 1.50, 1.60, 1.80, 2.0, 2.2, 2.4\}$.

The information of Chicó network can be found in the following doi: [10.4121/8703d289-71d3-4009-928a-de77f8ecb091](https://doi.org/10.4121/8703d289-71d3-4009-928a-de77f8ecb091)