



ESCUELA TÉCNICA SUPERIOR  
INGENIERÍA DE  
EDIFICACIÓN



UNIVERSITAT  
POLITÈCNICA  
DE VALÈNCIA



# PROJEKT:

## A NEW INNOVATIVE METHOD TO CONSTRUCT WIND TURBINE TOWERS USING CONCRETE AND STEEL

Professor adviser:

Prof. Dr.-Ing. Jens Minnert

Student:

Devesa Such, Eva Mtrkn: 5008023

## *Index*

---

- Introduction
  - Renewable energy
  - Wind energy
  - Wind turbine
- History
  - Nowadays in Europe
  - Wind energy in relation to the building
- Turbine types
  - Vertical axis
    - Darrieus
    - Savonius
    - Panémonas
  - Horizontal axis
    - Multi-blade rotors. Slow wind turbine.
    - Propeller type rotors. Fast wind turbine.
      - With respect to the wind
        - A windward
        - A leeward
      - By the number of blades
        - One blade
        - Two blades
        - Three blades

- The tower
  - Typology
    - Concrete tower
    - Lattice tower
    - Steel tubular tower
    - Braced steel tubular tower
- Advantages and disadvantages
- New wind turbines towers using concrete and steel
  - Building process
    - Foundation
    - Assembly of the hybrid tower
    - Building process
  - Calculations
    - Square tower
    - Triangular tower
  - Prices
    - Square tower
    - Triangular tower
    - Total prices
- Conclusion
- Acknowledgements
- Bibliography

## ***Introduction***

---

As Project Thesis of student from the "Escuela Técnica Superior de Ingeniería de Edificación" from Valencia and under the tutelage of Professor Jens Minnert, this thesis was carried out in the Technische Hochschule Mittelhessen of Giessen (Germany). I will treat a new innovative method to construct wind turbine towers using concrete and steel.

## *Renewable energy*

---

The use of energy, the generation and transmission are one of the activities that produce more negative impact on the environment.

However, compared to conventional sources, renewable energy, clean and inexhaustible resources provided by nature, have zero impact and it is always reversible. These renewable energies help reducing our country's dependence on external supplies and it helps to promote technological development and job creation.

There is different renewable energy sources, depending on the natural resources used to generate energy, as the reader can see below:

- Wind
- Small wind
- Small hydro
- Biomass
- Biofuels
- Marine
- Solar photovoltaic
- Solar thermal
- High enthalpy geothermal
- Low enthalpy geothermal

## *Wind energy*

---

The use of wind energy, kinetic energy possessed by a mass of air, is very old. This energy has been used during many years by people to drive ships with sails, to operate mills, ...

In the twentieth century began the use of wind energy for electricity generation. At the beginning it was used as a self-sufficiency through small installations. However, in the last decade of the twentieth century, thanks to technological development and increased competitiveness in economic terms, wind power has become in one more option to power consumption.

## *Wind turbine*

---

A wind turbine is a turbine driven by wind power. Is a Turbomachine that swaps the quantity of movement with the wind, by rotating a rotor. This mechanical energy can be used for various applications such as pumping water, in the case of windmills, for power generation in the turbine or for milling, windmills.



The evolution of millions of years is the result of the changes in the design of the wind turbines towers. Nowadays, there is a huge variety of these towers, and are classified in vertical and horizontal axis types.

The smallest wind turbines are utilized to produce clean, emissions-free power for individual homes, farms, and small businesses; while large grid-connected arrays of turbines are becoming an increasingly important source of wind power-produced commercial electricity.

## *History*

---

Wind power is one of the oldest form of energy used by mankind. At first they used the windmills, which transformed the wind into usable energy, they were used to pump water, grind grain, ...



*Dutch windmill photography*

The oldest windmill which there is reference of a mill that was used to make it work an organ in the first century. In the seventh century, mills were constructed in Afghanistan for practical use and had vertical axis, blades were rectangular and had between 6-8 blades covered with cloth.

In the twelfth century emerged the first mills in Europe, in France and England and there were distributed across the continent. The structure, called mill towers, was made of wood and it was rotated by hand around the center post to lift the blades. These mills were developed in France during the fourteenth century.





Formerly, the mills were consisted by a horizontal shaft protruding from the top. From this axis departed from four to eight blades, with a length between three and nine meters. Wooden beams were covered with fabric or planks of wood. The horizontal axis windmills were used mainly in Western Europe to grind wheat.



*Spanish windmill photography*

Moreover, in the United States developed mills pumping characteristic for their multiple metal blades. These mills contributed to the expansion of the railway, supplying the water requirements for the steam locomotives.



*Pumping windmills photography*

In the early eighties sparked interest in renewable energy, due to the first oil crisis in the seventies and it above all by the anti-nuclear movement in the 80s in Europe. Therefore, it was sought alternatives that were ecological and economically profitable. As the aerogenerators were expensive, international governments promoted wind energy in the form of research programs and grants.

Thereby, research institutes were created as the German Institute for Wind Energy (DEWI), which over time it has carried out a standardization of facilities, security methods and it are pursuing better economic performance of the facilities.

The costs were reduced up to 50% from 1981. Wind power is considered by environmental organizations as cheaper energy sources.

Nowadays, the aerogenerators generate a significant portion of the world's electricity and the countries with more energy installed worldwide are Germany, USA and Spain, although I must say that the design is still in development.

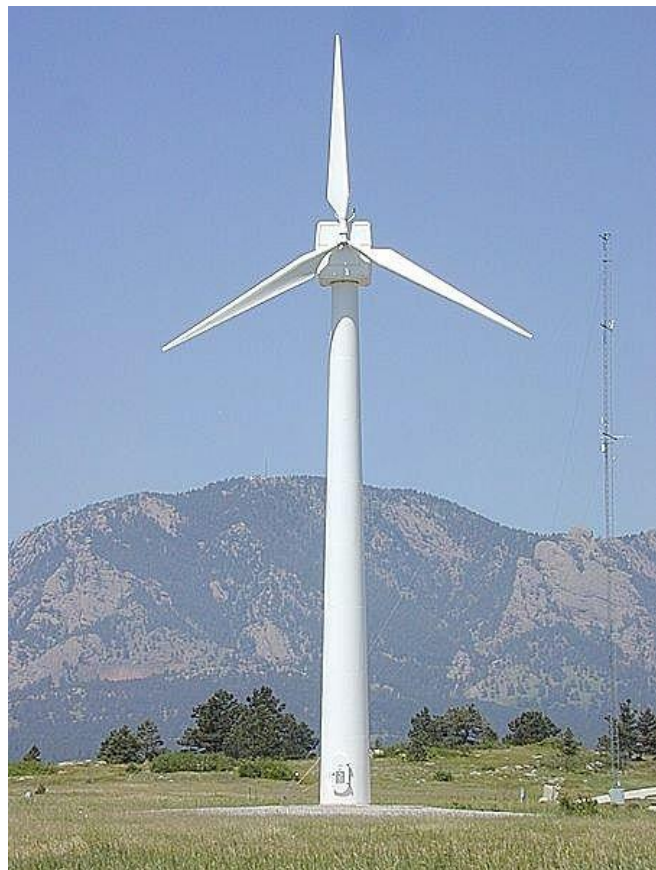

*Aerogenerator photography*

## *Nowadays in Europe*

---

The use of wind power in Europe has a substantial impact on energy security and the environment can boost the economy, since the introduction of this it would create green jobs, technology exports, reduce electricity costs and also it reduce petroleum use. Because as we know, the European continent has no large reserves of fossil fuels, and it is importing more than half of the energy used.

In recent years we have taken advantage of the climate and renewable energy industry giving it a fortress and creating hundreds of thousands of jobs.

In 2012, investments in renewable energy fell in some countries like Spain which was reduced around 68 percent. Recently, a report from the European Commission indicated that we need to intensify our efforts if we are to have some chance of achieving the 2020 goals.

We urgently need new policy initiatives. We must readjust the carbon credit market and make it work, and we also need to remove administrative and technical barriers, and we need to improve the electricity grid. Above all this, we need a new framework for 2030 climate and energy policy.

The European Commission's Green Paper urgently needs to be followed up by concrete policy proposals. It would be the worst possible outcome if this key challenge were neglected with the buck merely passed to the next Commission. In practical terms, this could mean that the fundamental uncertainty about the industry's framework conditions would linger on until 2017 or 2018, effectively spelling disaster for the industry.

An ambitious CO<sub>2</sub> reduction target stands at the heart of the new framework, since it will determine the level of environment policy ambition and the quota price. But if the new framework is truly contribute to boosting innovation and employment, it is essential that it also contains a binding target for renewable energy.

This will on the one hand help avoid a disproportionately large part of investment going into nuclear power, which may be climate friendly, but it would also sustain a centralised and inflexible energy supply while this is expensive and risky. On the other hand, a renewable energy target will push Member States to make concrete plans to achieve such targets. Furthermore, it will provide grid companies with a concrete policy basis when planning the expansion of the electricity grid.

Last but not least, a renewable energy target will help ensure continued investment in what is definitively one of Europe's industrial strongholds. Every year wind energies contribute more than €27 billion to the European economy, and it provides employment for more than 280,000 people across the continent.

If we manage to restore confidence this figure will rise over half a million jobs by 2020, surpassing the steel industry sector. But we urgently need to get going. Others have spotted the potential too: while renewable energy investment fell last year in Europe, it rose by 20 percent in China.

The truth is that even if Europe is a standstill, the rest of the world is still on the move. Yet, if we manage to get our act together and create a new strong climate and energy policy framework for 2030, the wind industry has the potential to revitalize Europe's ailing economy.

Wind power Installed in Europe by end of 2012 (cumulative)

	<b>Installed 2011</b>	<b>End 2011</b>	<b>Installe d 2012</b>	<b>End 2012</b>
<b>EU Capacity (MW)</b>				
Austria	73	1.084	296	1.378
Belgium	191	1.078	297	1.375
Bulgaria	28	516	168	684
Cyprus	52	134	13	147
Czech Republic	2	217	44	260
Denmark	211	3.956	217	4.162
Estonia	35	184	86	269
Finland	2	199	89	288
France	830	6.807	757	7.564
Germany	2.100	29.071	2.415	31.308
Greece	316	1.634	117	1.749
Hungary	34	329	0	329
Ireland	208	1.614	125	1.738
Italy	1.090	6.878	1.273	8.144
Latvia	17	48	21	68
Lithuania	16	179	46	225
Luxembourg	1	45	0	45
Malta	0	0	0	0
Netherlands	59	2.272	119	2.391
Poland	436	1.616	880	2.497
Portugal	341	4.379	145	4.525
Romania	520	982	923	1.905
Slovakia	0	3	0	3
Slovenia	0	0	0	0
Spain	1.050	21.674	1.122	22.796
Sweden	754	2.899	846	3.745
United Kingdom	1.298	6.556	1.897	8.445
<b>Total EU-27</b>	<b>9.664</b>	<b>94.352</b>	<b>11.895</b>	<b>106.040</b>
<b>Total EU-15</b>	<b>8.524</b>	<b>90.145</b>	<b>9.714</b>	<b>99.652</b>
<b>Total EU-12</b>	<b>1.140</b>	<b>4.207</b>	<b>2.181</b>	<b>6.388</b>

**Wind power capacity installations**

During 2012, 12,744 MW of wind power was installed across Europe, of which 11,895 MW was in the European Union.

In terms of annual installations, Germany was the largest market in 2012, installing 2,415 MW of new capacity, 80 MW of which (3.3%) offshore. The UK came in second place with 1,897 MW, 854 MW of which (45%) offshore, followed by Italy with 1,273 MW, Spain (1,122 MW), Romania (923 MW), Poland (880 MW), Sweden (845 MW) and France (757 MW).

Among the emerging markets of Central and Eastern Europe, Romania and Poland both had record years - both installing around 7.5% of the EU’s total annual capacity. Both markets are now consistently in the top ten in the EU for annual installations.

It is also important to note the amount of installations in the UK, Italy and Sweden. These three markets represent respectively 16%, 11% and 7% of total EU installations in 2012.

Offshore accounted for 10% of total EU wind power installations in 2012, one percentage point more than in 2011.

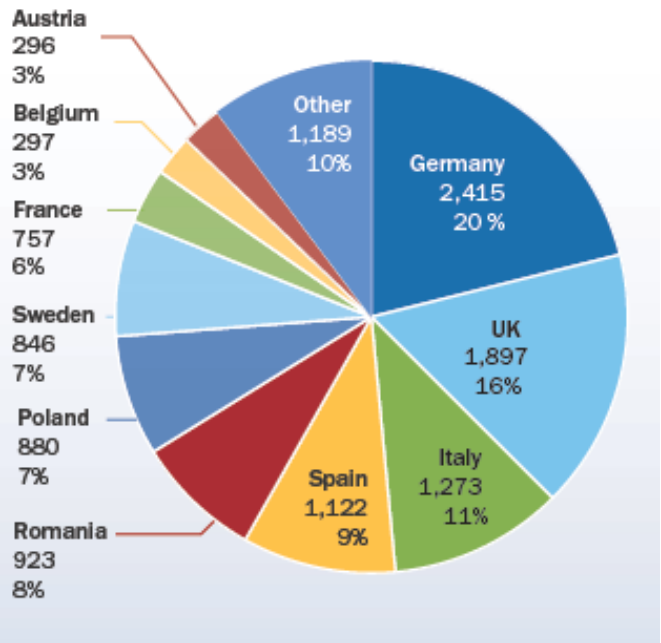

*EU member state market shares for new capacity installed during 2012 in MW. Total 11,566 MW*

## Power capacity installations

Wind power accounted for 26.5% of new installations in 2012, the second biggest share after solar PV (37%) and before gas (23%).

Solar PV installed 16 GW (37% of total capacity), followed by wind with 11.9 GW (26.5%), and gas with 10.5 GW (23%).

No other technologies compare to wind, PV and gas in terms of new installations. Coal installed 3 GW (7% of total installations), biomass 1.3 GW (3%), CSP 833 MW (2%), hydro 424 MW (1%), waste 50 MW, Nuclear 22 MW, fuel oil 7 MW, ocean technologies 6 MW and geothermal 5 MW.

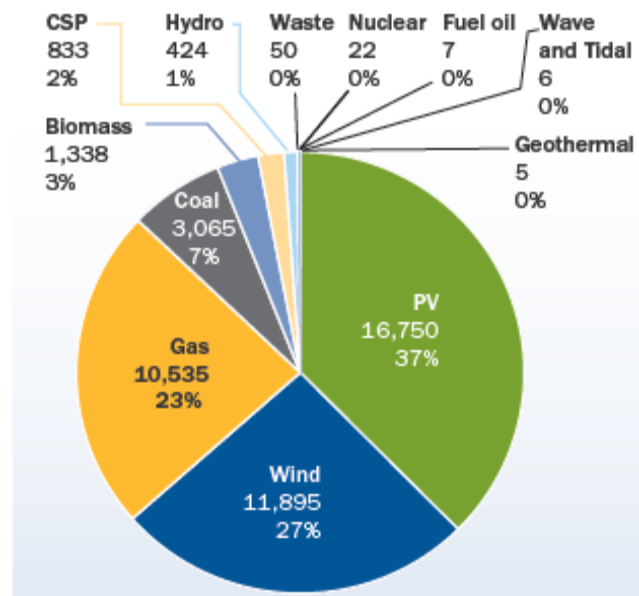

Share of new power capacity installations in EU.  
Total 44,601 MW

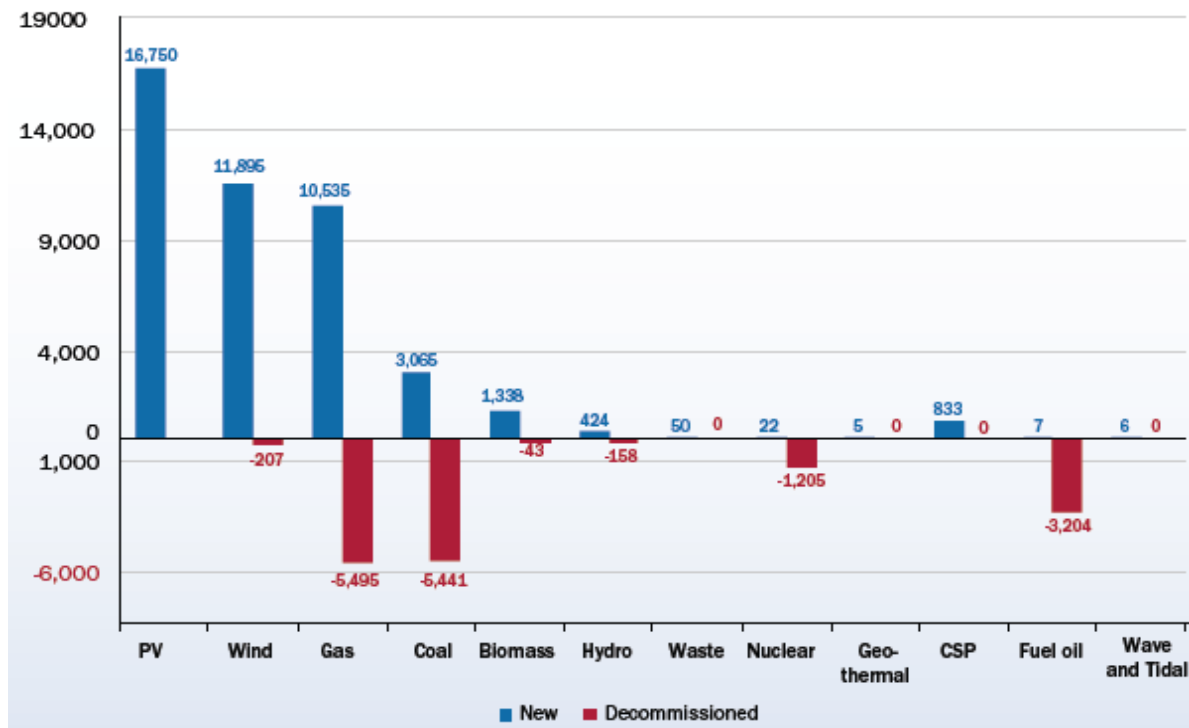

New installed power capacity and decommissioned power capacity in MW



Overall, during 2012, 44.9 GW of new power generating capacity was installed in the EU, 1.7 GW less than in 2011, which was a record year for new power capacity installations.

During 2012, 5.5 GW of gas capacity was decommissioned, as were 5.4 GW of coal, 3.2 GW of fuel oil and 1.2 GW of nuclear capacity.

After two years of installing more capacity than it decommissioned, coal power installations reduced almost 2.4 GW in 2012.

**Renewable power capacity installations**

In 2012, a total of 31 GW of renewable power capacity was installed. Almost 70% of all new installed capacity in the EU was renewable. It was, furthermore, the fifth year running over 55% of all new power capacity in the EU was renewable.

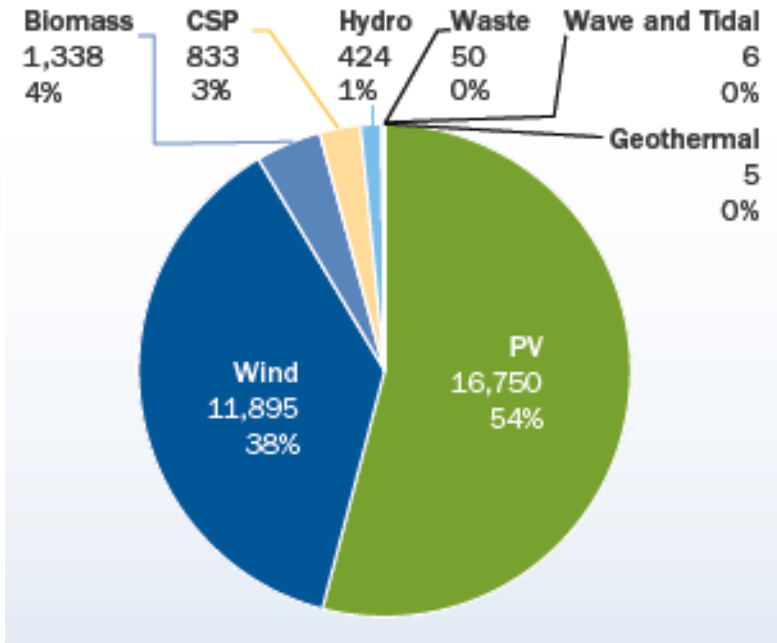

*Share of new renewable power capacity installation in MW. Total 30.968 MW*



# Trends & cumulative installations

## Renewable power capacity installations

In 2000, new renewable power capacity installations totalled a mere 3.5 GW. Since 2010, annual renewable capacity additions have been between 24.5 GW and 33.7 GW, seven to eight times higher than at the turn of the century.

The share of renewables in total new power capacity additions has also grown. In 2000, the 3.5 GW represented 20.7% of new power capacity installations, increasing to 31.3 GW representing 70% in 2012.

353 GW of new power capacity has been installed in the EU since 2000. Of this, almost 28% has been wind power, 51% renewables and 91% renewables and gas combined.

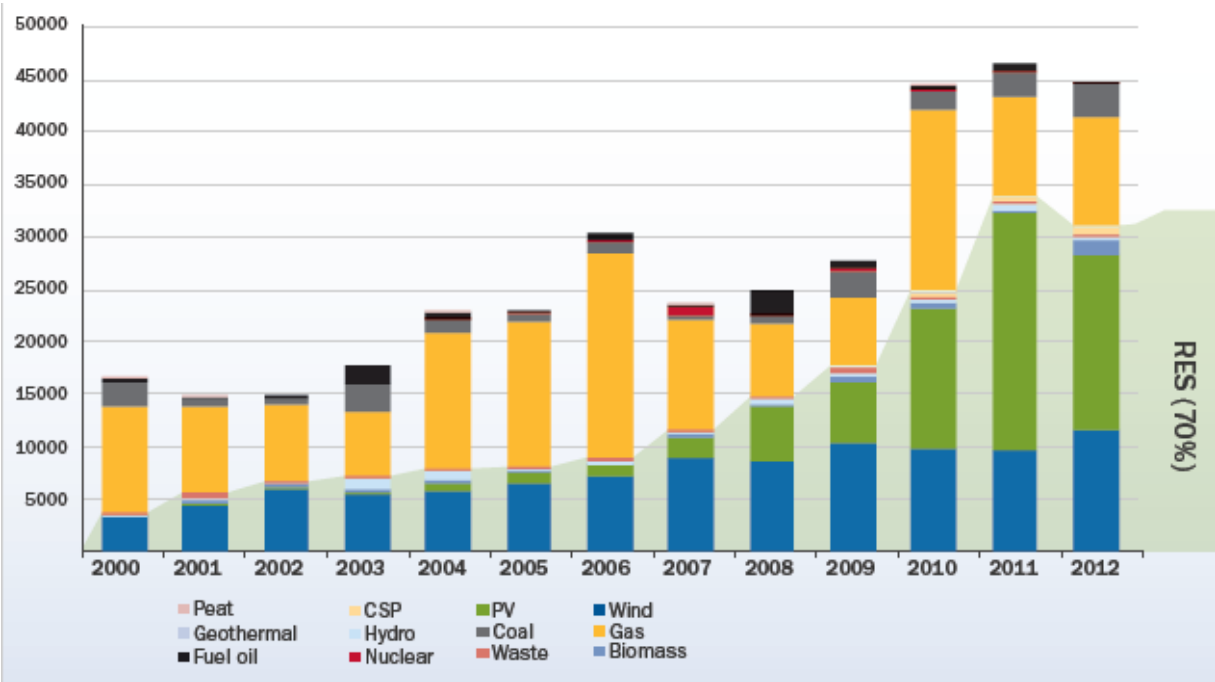

*Installed power generating capacity per year in MW and RES share (%)*

## Net changes in EU installed power capacity 2000-2012

The net growth since 2000 of gas power (121 GW), wind (96.7 GW) and solar PV (69 GW) was at the expense of fuel oil (down 17.4 GW), nuclear (down 14.7 GW) and coal (down 12.7 GW). The other renewable technologies (hydro, biomass, waste, CSP, geothermal and ocean energies) have also been increasing their installed capacity over the past decade, albeit more slowly than wind and solar PV.

The EU's power sector continues to move away from fuel oil, coal and nuclear while increasing its total installed generating capacity with gas, wind, solar PV and other renewables.

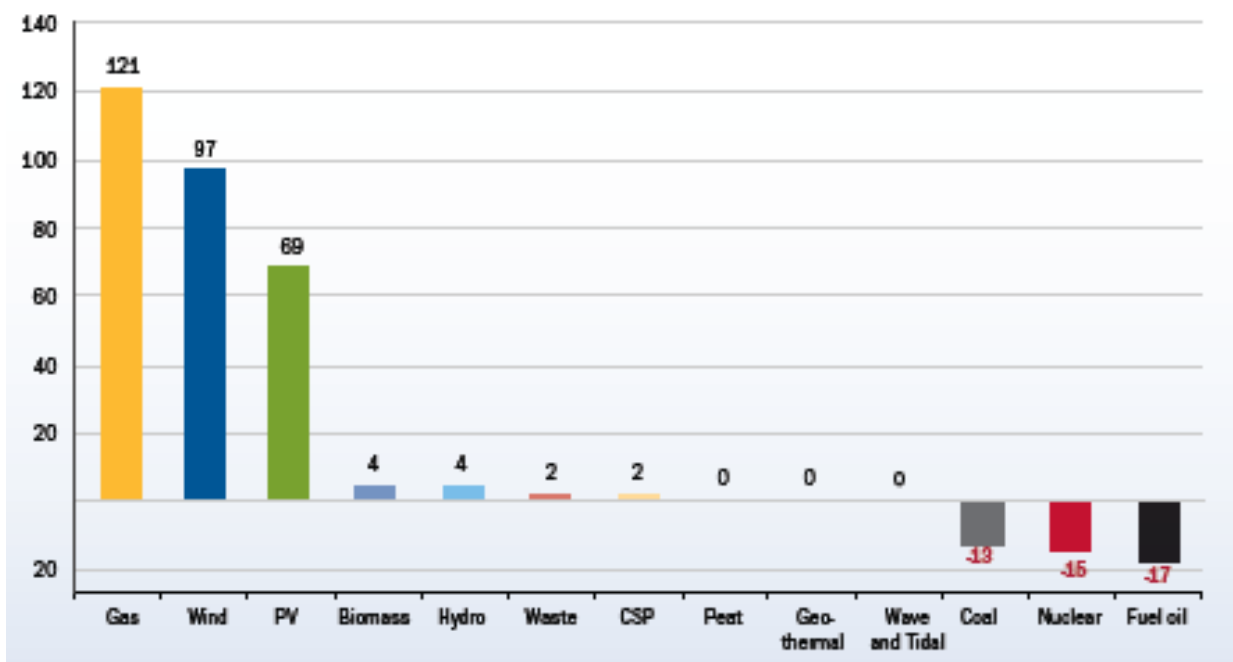

*Net electricity generating installations in the EU 2000-2012 (GW)*

**Total installed power capacity**

Wind power’s share of total installed power capacity has increased five-fold since 2000; from 2.2% in 2000 to 11.4% in 2012. Over the same period, renewable capacity increased by 51% from 22.5% of total power capacity in 2000 to 33.9% in 2012.

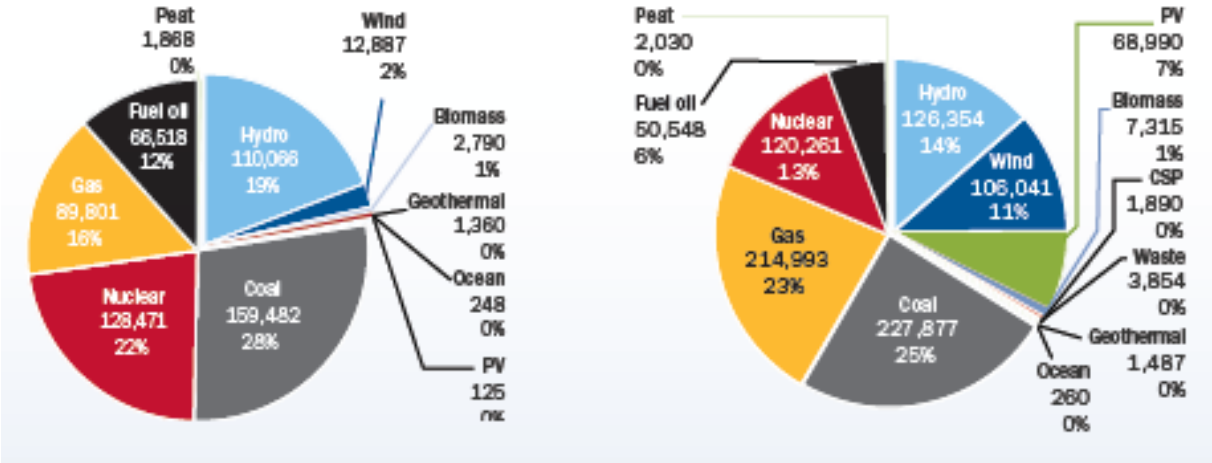

*EU power mix 2000*

*EU power mix 2012*

**A closer look at wind power installations**

**Total installed power capacity**

Annual wind power installations in the EU have increased steadily over the past 12 years from 3.2 GW in 2000 to 11.9 GW in 2012, a compound annual growth rate over 11%.

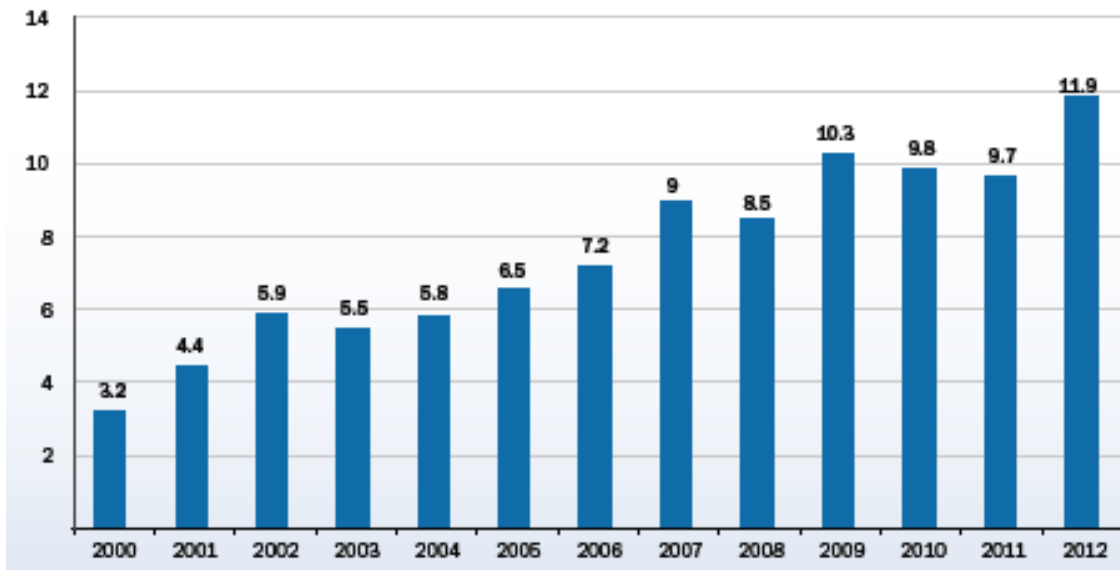

*Annual wind power installation in EU (GW)*

### National breakdown of wind power installations

In 2000, the annual wind power installations of the three pioneering countries – Denmark, Germany and Spain – represented 85% of all EU wind capacity additions. In 2012, this share had decreased to 32%. Moreover, in 2000, the countries that make up, today, the 12 newer EU Member States (Bulgaria, Cyprus, Czech Republic, Estonia, Hungary, Latvia, Lithuania, Malta, Poland, Romania, Slovakia and Slovenia) had no wind energy; in 2012, they represented 18% of the EU’s total market.

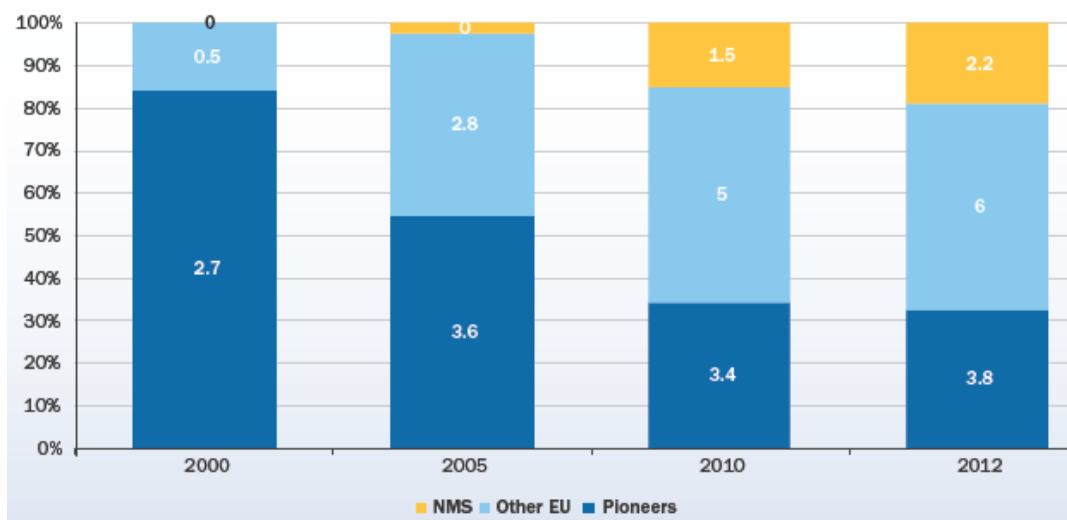

*Denmark, Germany and Spain’s share of EU wind power market (GW)*

**Onshore and offshore annual markets**

2012 was a record year for offshore installations, with 1,166 MW of new capacity grid connected. Offshore wind power installations represent 10% of the annual EU wind energy market, up from 9% in 2011.

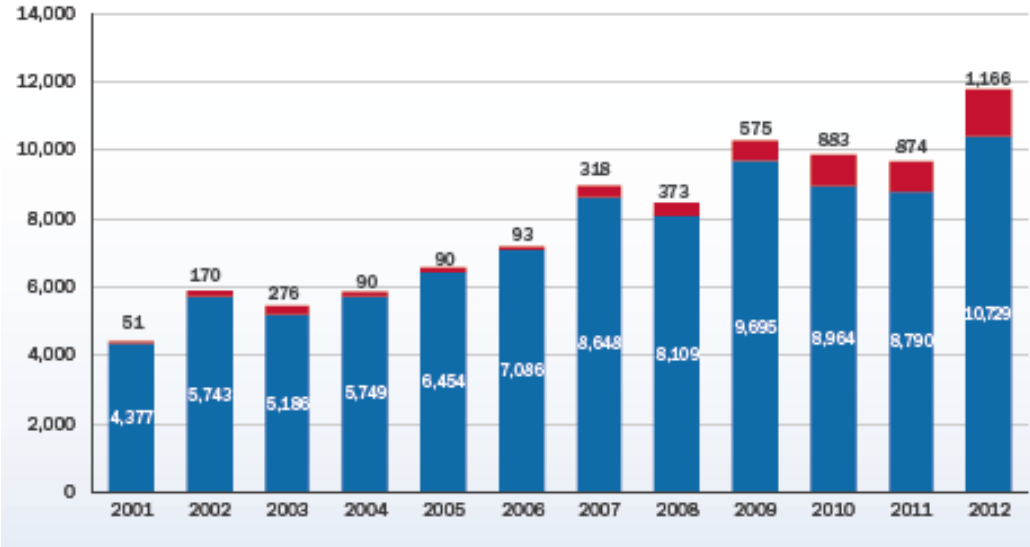

*Annual onshore and offshore installations (MW)*

**Cumulative wind power installations**

A total of 106 GW is now installed in the European Union, a growth of 12.6% on the previous year and similar to the growth recorded in 2011. Germany remains the EU country with the largest installed capacity, followed by Spain, Italy, the UK and France. Ten other EU countries have over 1 GW of installed capacity: Austria, Belgium, Denmark, Greece, Ireland, The Netherlands, Poland, Portugal, Romania and Sweden.



Germany (31.3 GW) and Spain (22.8 GW) have the largest cumulative installed wind energy capacity in Europe. Together they represent 52% of total EU capacity. The UK, Italy and France follow with, respectively, 8.4 GW (8% of total EU capacity), 8.1 GW (8%) and 7.6 GW (7%). Amongst the newer Member States, Poland, with 2.5 GW of cumulative capacity, is now in the top 10, in front of the Netherlands, and Romania is eleventh with 1.9 GW (1.8%).



**Estimated wind energy production**

The wind capacity installed at the end of the year 2012 will produce, in a normal wind year 231 TWh of electricity, representing 7% of the EU’s gross final consumption.

According to this methodology Denmark remains the country with the highest penetration of wind power in electricity consumption (27.1%), followed by Portugal (16.8%), Spain (16.3%), Ireland (12.7%) and Germany (10.8%). Of the newer Member States, Romania has the highest wind energy penetration (6.9%).

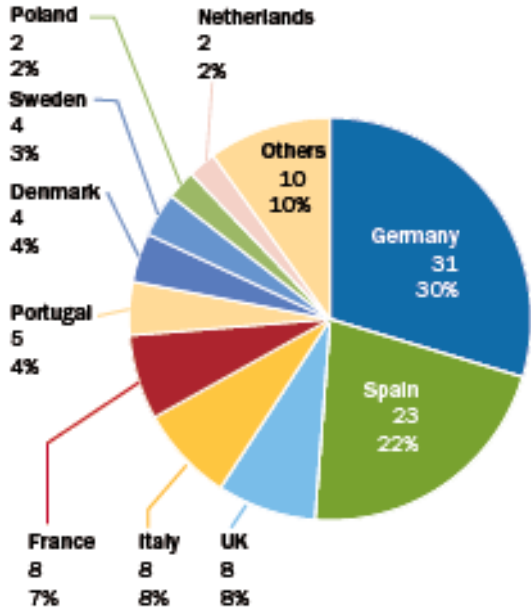

*EU member state market shares for total installed capacity. Total 106 GW*

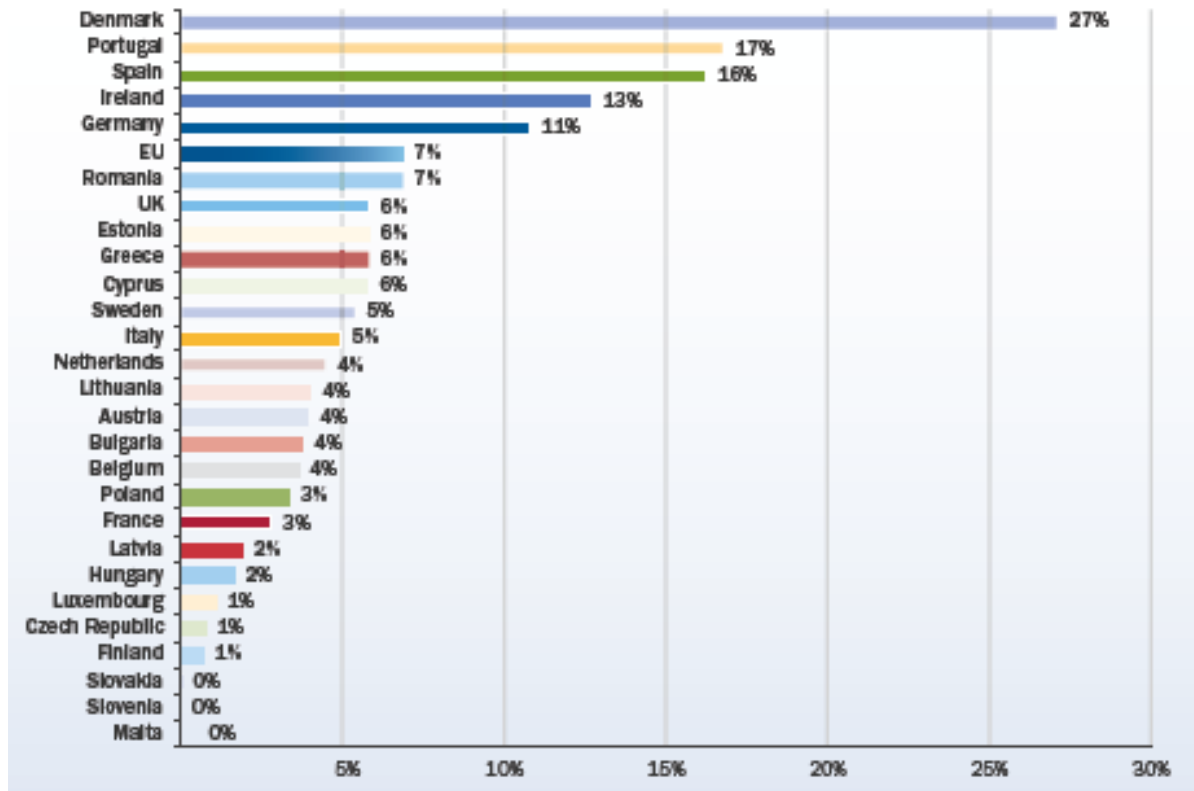

*Wind power share of total electricity consumption in EU (7%) and in member states*

## Wind power targets

Despite the growth of annual wind energy installations in 2012 and cumulative capacity reaching 106 GW, wind energy deployment is lagging behind the objectives the EU Member States set themselves in their National Renewable Energy Action Plans (NREAPs). Comparison with the NREAPs does not take into account any subsequent changes to targets. In 2012, installations were higher than EWEA's expectations.

In 2009, the EWEA published a growth scenario that expected cumulative capacity in the EU to be 103 GW at the end of 2012. However, EWEA's scenario reaches 230 GW of installed wind energy capacity in 2020, whereas the sum of the Member State's NREAP's is 213 GW. The latter suggests that whereas EWEA took a gradual approach with annual installations increasing slowly at the beginning and more rapidly towards 2020, the Member States, on the whole, "front-loaded" their trajectories.

	Onshore 2012		Offshore 2012		Total 2012		Difference 2012			
	NREAP	Real	NREAP	Real	NREAP	Real	Onshore	Offshore	Total	
Austria	1,435	1,378	0	0	1,435	1,378	-57	0	-57	-4%
Belgium	720	996	503	380	1,223	1,375	276	-124	152	12.5%
Bulgaria	451	684	0	0	451	684	233	0	233	51.7%
Cyprus	114	147	0	0	114	147	33	0	33	28.9%
Czech Rep	343	260	0	0	343	260	-83	0	-83	-24.2%
Denmark	2,985	3,241	856	921	3,841	4,162	256	65	321	8.4%
Estonia	311	269	0	0	311	269	-42	0	-42	-13.5%
Finland	380	262	0	26	380	288	-118	26	-92	-24.2%
France	7,598	7,564	667	0	8,265	7,564	-34	-667	-701	-8.5%
Germany	30,566	31,027	792	280	31,358	31,307	461	-512	-51	-0.2%
Greece	2,521	1,749	0	0	2,521	1,749	-772	0	-772	-30.6%
Hungary	445	329	0	0	445	329	-116	0	-116	-26.1%
Ireland	2,334	1,713	36	25	2,370	1,738	-621	-11	-632	-26.7%
Italy	7,040	8,144	0	0	7,040	8,144	1,104	0	1,104	15.7%
Latvia	49	68	0	0	49	68	19	0	19	38.8%
Lithuania	250	225	0	0	250	225	-25	0	-25	-10%
Luxembourg	54	45	0	0	54	45	-9	0	-9	-16.7%
Malta	2	0	0	0	2	0	-2	0	-2	-100%
Netherlands	2,727	2,144	228	247	2,955	2,391	-583	19	-564	-19.1%
Poland	2,010	2,497	0	0	2,010	2,497	487	0	487	24.2%
Portugal	5,600	4,523	0	2	5,600	4,525	-1,077	2	-1,075	-19.2%
Romania	1,850	1,905	0	0	1,850	1,905	55	0	55	3%
Slovakia	150	3	0	0	150	3	-147	0	-147	-98%
Slovenia	2	0	0	0	2	0	-2	0	-2	-100%
Spain	23,555	22,796	0	0	23,555	22,796	-707	0	-707	-3.2%
Sweden	2,311	3,582	97	164	2,408	3,745	1,269	67	1,336	55.6%
UK	5,970	5,497	2,650	2,948	8,620	8,445	-473	298	-175	-2%
<b>EU-27</b>	<b>101,773</b>	<b>101,048</b>	<b>5,829</b>	<b>4,993</b>	<b>107,602</b>	<b>106,041</b>	<b>-725</b>	<b>-836</b>	<b>-1,561</b>	<b>-1.5%</b>
<b>EWEA 2009 EU</b>		<b>98,000</b>		<b>5,300</b>		<b>103,300</b>				
<b>Difference EWEA 2009 and real</b>		<b>3,048</b>		<b>-307</b>		<b>2,741</b>				

*Wind power capacity targets, national renewable energy action plans and real (MW)*

Eighteen Member States are falling behind their wind power capacity trajectories. Because of these, the furthest behind are Slovakia (-147 MW, -98%), Greece (-772 MW, -30.6%), Czech Republic (-83 MW, -24.2%), Hungary (-116 MW, -26.1%), Portugal (-1,075 MW, -19%) and France (-701 MW, -8.5%). On the other hand, the nine other Member States are above their trajectory. Sweden is the most noteworthy with 1,336 MW more than forecast (+55%).

The EU overall is lagging by almost 1.6 GW (-1.5%). The next table also highlights that it is in offshore where there is the biggest discrepancy between the NREAPs and real installations. The Member States are trailing by 836 MW, -14%.



On the other hand compared to EWEA's 2009 forecast, onshore installations have increased faster than expected (+3,048 MW or +3%). However, offshore installations are below expectations by 307 MW or -6%.

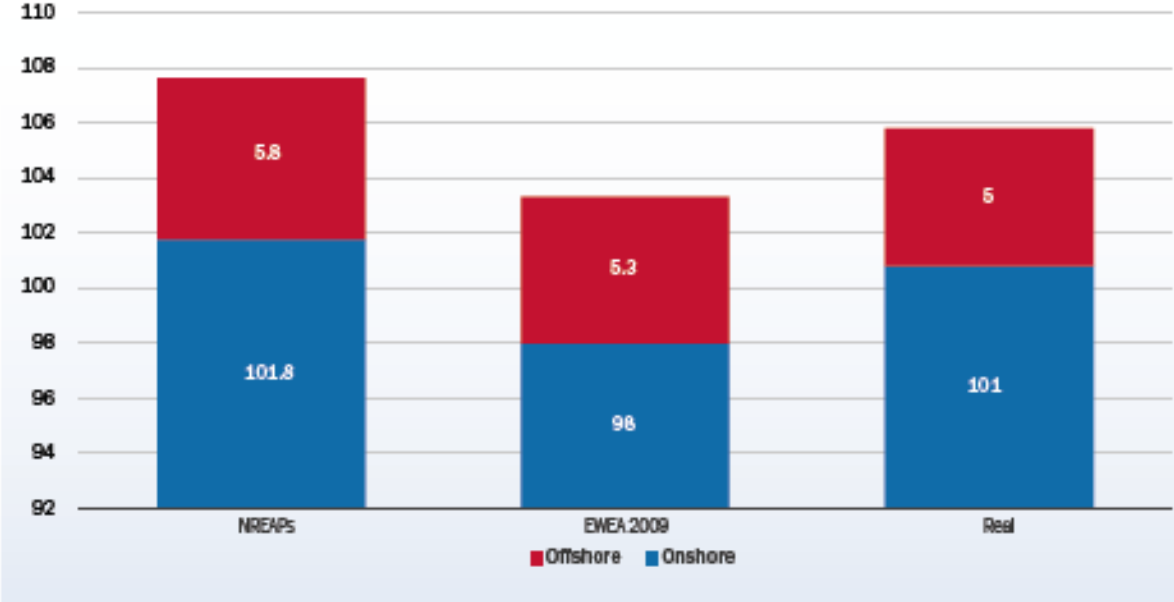

*Wind power capacity targets (NREAPS and EWEA 2009) and real (MW)*

## *Wind energy in relation to the building*

---

The wind energy input to buildings is a breakthrough in sustainable architecture. Currently, wind power seemed that was the patrimony of large tracts of land and high plains where to place wind turbines and thus transform large amounts of energy.

But it seems that this idea comes to an end with the new technologies. Because of the current tendencies indicate that each building must be self-sufficient to stock, to be sustainable. The aerodynamic design of buildings will help to have a better conduct of air currents and through turbine system will transform these currents in electric power needed by the building, photovoltaics being the complement in order to ensure self-sufficient energy. The design not only wind processing aid, but it also allows reduce the resistance of the building to the air currents requiring less amount of materials (concrete, steel, ...) for getting buildings lighter.



*Bahrain World Trade Center*

For this to work you need a system of electric generation based on turbines. Such use has a lot of advantages like proximity from the point of generation to the point of minimizing loss of energy consumption, accessibility for small economies, enabling hybrid facilities, etc.. In addition not pollute, not take up much space, require low maintenance and providing electricity can make a remarkable improvement in the quality of life.

So far wind energy projects are based on the use of vertical-axis turbine (instead of the traditional horizontal shaft) intended for buildings using wind from any direction and at different speeds. There are many models on the market, but especially noteworthy the model Windspire is a vertical axis wind turbine designed to meet the energy demand of houses and industrial premises or offices. It has a height of just over 9 meters which can be connected directly to the building's electrical grid. Highlight the design (meaning minimize visual impact), its quiet operation and its high capacity to generate energy.

## ***Turbine types***

---

The classification of wind turbines can be performed depending on the type of wind rotor and the arrangement of its axis of rotation. The turbines are classified on: rotor vertical axis and rotor horizontal axis.

### **VERTICAL AXIS**

The Vertical axis wind turbines are like wells, its main feature is that the axis of rotation is perpendicular to the ground. They are also called "VAWTs" corresponding to "Vertical Axis Wind Turbines."

Some advantages of this axis are:

- You can place the generator on the floor.
- You do not need a yaw mechanism to turn the rotor against the wind.

And some disadvantages:

- Wind speeds near ground level are very low, so their wind speeds in the lower part of the rotor will be very low.
- To replace the bearing of the main rotor necessitates removing the rotor and, in this case implies disassembling the entire machine.
- The average efficiency of these aerogenerators is not very good.

The most popular designs of the vertical axis are the Darrieus type rotors and the Savonius type rotors, and the Panémonas type also exist but are less well known.

## **Darrieus**

They are low power wind systems oriented primarily to meet minor demands, without connection to the local distribution network. It is named The French engineer Georges Darrieus who patented the design in 1931. These turbines are fairly simple and inexpensive, although of larger dimensions than Savonius and Panémonas turbines. These consist of two or three blades, and these are characterized by C-shaped blades which make it resemble an eggbeater.



These present some disadvantages such as: lack of torque, so it has to motorize the turbine to start spinning and use of additional tensioners to ensure structural stability.

## Savonius

Type of vertical axis turbine patented by Finnish Sigurd Savonius in 1922. Characterized by being made up of two blades which are halves of a cylinder cut by a generator and lateralemente displaced. Unlike the Darrieus, provide starting torque and these are easy to build, but because of their low yield and a reduced speed, make that their main application is in water pump systems.

Some designs combine in the same axis a Savonius in the center with a Darrieus in the outside.



## Panémonas



These turbines are composed of four or more semicircles attached to the central axis. Its performance is low. In the fifth century B.C. are found the first windmills in Asia. The Chinese used since time immemorial these windmills, which were used to pump water, ...

## **HORIZONTAL AXIS**

The horizontal axis turbines are the most used because, in general, have achieved a higher efficiency than the vertical axis.

In them has focused the design effort in recent years. They are also called "HAWTs", which corresponds to the English name that stands for "Horizontal Axis Wind Turbines".

The horizontal axis rotors are characterized because their blades rotate in the perpendicular direction to the incident wind speed. The purpose of the rotor is to convert the linear motion of the wind into rotational energy that can be used to work the generator.

### **Multi-blade rotors. Slow wind turbine**

These are characterized by having between 5 and 24 numbers of blades and hence a high strength. These have high starting torque and low speed. The linear velocity at the tip of the blade of these machines in terms of the design, is the same order as the incoming wind speed.

These turbines are used to pump water and these are not used in applications generating electricity for its low rpms.



## **Propeller types rotors. Fast wind turbine**

These rotors rotate faster than the multi-blade rotors. The linear velocity at the tip of the blade varies between 6 and 14 times the speed of wind incident on design conditions.

These turbines are very suitable for power electrical generation because the mechanical element adjusts the rotational speed of the turbine with the generator speed which is smaller in size and cost. The propeller type rotors have a reduced starting torque that most of the time, this is sufficient to rotate the rotor during the connection process.

The propeller type rotors can be classified according to different criteria: by the team's position with respect to the wind or by the number of blades.

- **With respect to the wind**

The propeller type rotors can be classified depending on its arrangement in front of the incident wind speed. So that the turbines can be designed to work on windward or leeward.

- A windward (upstream)

They have the rotor facing the wind, as this wind, in its direction of flow, which is before the blades to the tower. The main advantage is that it avoids the wind coat behind the tower.

One drawback is that you need a yaw mechanism to keep the rotor facing into the wind.



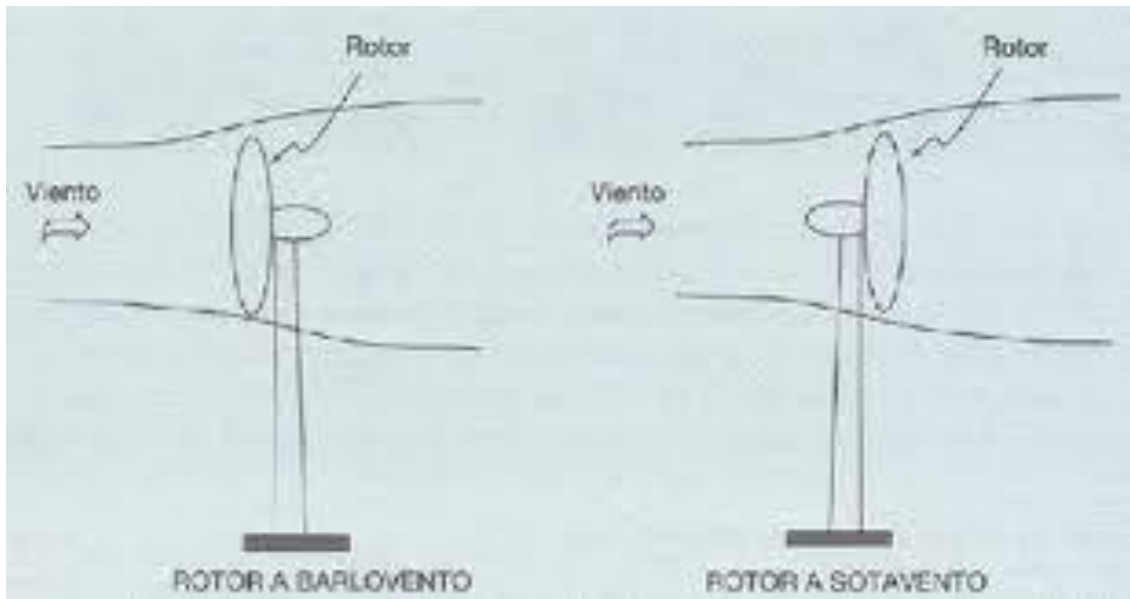

- A leeward (downstream)

They have the rotor on the lee side of the tower. The main advantage is that they can be constructed without an orientation mechanism, if the rotor and nacelle have a suitable design which makes the nacelle follow the wind passively. This system is based in slightly tilted the blades such that in its rotational motion describes a cone.

The main drawback is the fluctuation of wind power due to the rotor passing through the coat of the tower, which can create more fatigue loads on the turbine that with a upstream design.

- **By the number of blades**

- One blade:

Its main advantage is cost reduction. But these have more disadvantages because of having only one blade, require a counterweight at the opposite end to the blade to balance the rotor. The big drawback is that they introduce in axis some highly variable efforts, which shortens the life of the installation.



- Two blades:



The advantage offered by these turbines is that they save the cost of a shovel and of course, weight. But often these have difficulty penetrating in the market, because they require higher speed to produce the same output power. This is a disadvantage in regard to noise and in the visual appearance.

- Three blades:

The most modern designs have this design, with the rotor to windward, using electric motors in their yaw mechanism. This design tends to be a standard for the rest of the concepts evaluated, mainly due to its good structural stability and aerodynamics, reduced noise emissions and greater energy efficiency compared to one or two rotor blades.



## *The tower*

---

The tower is one of the main components of a horizontal-axis turbine. This is an advantage and a disadvantage. The disadvantage is the high cost in that is involved, as it can cost about 20% of the total cost of the turbine.

One of the important design features of the tower is height. The greater the height of the tower, the power production of the turbine increases. However, increased tower height implies increased cost and greater difficulty in installation of equipment. Theoretically the best height of the tower is the crossing point the construction of the two functions: cost and energy efficiency. Therefore, the choice of tower height responds to a compromise between the advantages and disadvantages involved in increase this parameter design. In the larger turbines, construction costs increase more rapidly with height of the tower than in small turbines. The materials suitable for construction are the concrete or the steel, in the second case the structure varies from lattices, until tubular towers, with or without tie rods.

After the height, stiffness is the second important design parameter of a tower, which must submit sufficient rigidity to withstand the thrust loads transmitted by the wind rotor, and wind loads exerted along the tower. Moreover, the structural design of the tower must fix its natural bending frequency such that in any operating condition stable is excited this resonant frequency. To fix this frequency is a key factor in the design because is linked with the required material and thus, with construction costs. The result of the design of the tower is to perform the desired tower with the required stiffness to the lowest possible cost of construction.

The technical requirements posed by the entire system as a whole can be known by almost a variant: the optimal economy, but only these are achieved with a sensible combination of requirements that exist for wind turbines, the location and selection of tower design. This clearly shows that the wind turbine tower is a conventional component when it is considered in isolation, however, its structural design requires a general knowledge of the operation of the overall system and application.

Apart from this functional aspect should not be overlooked that the tower determines the outward appearance of the turbine. So, to aesthetics should be granted due attention, even if it involves some additional cost.

- **TYOLOGY**

In antiquity, the windmills hadn't towers, these had the interior of the mill. Compared to the rotor diameter had a low and bulky construction, in keeping with the role of "workroom." But soon people realized the advantage of increased height, and the design of the windmill began to change, becoming more slender and more like a tower.

As a result of this development, the design and the materials of the towers increased in variety. So, steel and concrete took the place of the wooden constructions.

The towers can be concrete, tubular towers or lattice towers. Comparing the tubular with the lattice, the main advantage of lattice towers is that they are cheaper, but the most of the towers are of tubular freestanding steel because of its high strength and its lower visual impact. The structural optimization of the latter leads to a truncated cone shape with a gradual reduction of the diameter from the base to the gondola, although it affects more complex construction and higher cost. Moreover, these tubular towers are safer for service personnel turbines, compared to those of lattice, because of they use a staircase to access to the top of the turbine. The following defines the different types available:

- **Concrete tower**

The structure of such towers may be performed with reinforced concrete or prestressed concrete.

In the thirties, reinforced concrete towers back then reinforced with steel, were used for so-called aeromotors in Denmark. Nowadays, those towers are characteristic of a large Danish experimental turbines. Currently, the concrete towers are constructed in a conventional manner with reinforced concrete or prestressed concrete as in testing of the British turbines LS-1 or the Swiss WTS-75.

The prestressed concrete is more expensive but it has better features for high stiffness towers than the reinforced concrete, and it is also an economically competitive option with the tubular steel towers when these must be designed with high rigidity.

In some cases, prefabricated concrete towers produced in 2 or 3 sections by special machines in the factory are used because building the tower at the site with the usual method initiated is usually considered a disadvantage of the concrete construction.

There exist other designs based on the use of tensioners anchored to the ground to stiffen the tower, or mixed towers formed by an upper section of steel mounted on a concrete base.



- **Lattice tower**



The three-dimensional lattice tower, is the simplest way to build a tower high and rigid. This tower is a metal structure that underpins the wind rotor and the mechanical components of the transmission. Lattice towers were the favorite designs for the first tests of turbines and these continue to be today the smallest turbines in some cases. Close to a height of 30 meters, the lattice is a common practice. The main advantage is that they have a low cost but these have the disadvantage of poor accessibility difficult maintenance. And another disadvantage is the visual that impact cause at near distances of the tower, however this type of tower are

confused with the horizon when the machine is observed at a distance far enough.

- **Steel tubular tower**

Today, this type of tower is the most widely used. The first tubular steel towers had a high structural stiffness, these were designed such that the natural bending frequency of the tower was greater than the rotational frequency of the blade. The reason for this choice was performed to reduce the possibility to excite this natural frequency of the system. This rigid design made that the towers were very heavy and expensive, especially when these had greater height. The new tubular steel towers are designed so that the bending natural frequency is less than the frequencies of rotation of the blades.

The manufacturing the simplest approach of the tubular towers is by joining of several cylindrical sections. The usual number of sections is usually two or three, for tower heights above 60 meters. In high towers height is usually the design truncated cone with steel plate decreasing thickness with height to reduce weight.



- **Braced steel tubular tower**



The downwind rotor machines allow tubular steel towers more slender. These are anchored to the ground with steel cables, in some cases with rigid struts to support the required flexural rigidity. The guyed tubular steel towers, are used for downwind rotors especially when the height of the tower is very large compared with the diameter of the rotor.

Despite its relatively small overall mass, the guyed towers don't have a very good cost-efficiency. In addition, the straps and anchors required to increase the total cost. Also, the straps are considered a nuisance in areas devoted to agriculture.



## *Advantages and disadvantages*

---

### **ADVANTAGES**

- Wind power does not pollute, it is inexhaustible and it slows fossil fuel depletion helping to prevent climate change. It is a fully mature technology use and setup.
  - It is one of the cheapest sources, it can compete in profitability with other traditional energy sources like coal power plants (traditionally considered the cheapest fuel), the fuel stations and even with the nuclear energy, considering the costs to repair environmental damage.
- The generate electricity without any combustion process or thermal processing stage involves, from the environmental point of view, a procedure very favorable for being clean, free from pollution problems, etc. The impacts originated by the fuels during the extraction, transformation, transportation and combustion are deleted radically, which benefits the atmosphere, soil, water, wildlife, vegetation, etc.
  - The electricity produced by a wind turbine prevents daily are burned thousands of liters of oil and thousands of kilograms of black lignite in the power centrals.

- The use of wind power to generate electricity has no effect on the physicochemical characteristics of the soil or erodibility, because of producing no contaminant incident on this medium, nor discharges or large earthworks.
  - Contrary to what may happens with conventional energy, wind energy does not produce any alteration on the aquifers, nor by waste pollution or discharges. The generation of electricity from wind does not produce toxic gases, it does not contribute to the greenhouse effect, or destroy the ozone layer, and it does not create acid rain. It does not create hazardous byproducts nor polluting waste.
- It prevents contamination involved in transporting fuels; gas, oil, diesel, coal. It reduces heavy maritime traffic and it land near the centrals. It removes the risk of accidents during these transports: cleaning and oil slicks

from tankers, nuclear waste shipments, etc. It is not necessary to install supply lines: pipelines to refineries or gas centrals.

Wind energy is independent of any political or business relationship, it is obtained mechanically and it is therefore directly usable. As for his transformation into electricity, this is done with excellent performance and not through thermodynamic apparatuses with a Carnot small performance.

- Although wind turbines can be very tall each takes up only a small plot of land. This means that the land below can still be used. This is especially the case in agricultural areas as farming can still continue.
  - Remote areas that are not connected to the electricity power grid can use wind turbines to produce their own supply.
- Wind turbines are available in a range of sizes which means a vast range of people and businesses can use them. Single households to small towns and villages can make good use of range of wind turbines available today.

## DISADVANTAGES

- The air to be fluid the small specific weight, involves manufacture large machines and consequently expensive. Its height can match that of a building of ten or more plants, while the total size of the blades reaches twenty meters, which makes that the production increase the cost.
  - From the aesthetic point of view, wind power produces an unavoidable visual impact, because of their characteristics normally requires sites about that happen to be the more evident the presence of the machines (mountains, hills, coast). In this sense, the implementation of large-scale wind power, can produce a clear alteration of the landscape, which must be evaluated in terms of the previous situation existing at each location.
- There are two sources of noise in a turbine in operation: mechanical and aerodynamic. The mechanical noise proceeds of the generator, the gearbox and the connections, and these can easily be reduced by conventional techniques. The natural aerodynamic noise, produced by the movement of the blades, is more difficult to treat by conventional methods.

- A negative impact is the noise produced by the rotation of the rotor, but its effect is just the defendant for installation generated an industrial type like entity, and whenever we are very close to the mills. Four factors determine the noise nuisance:
    - The actual noise produced by the wind turbine.
    - The position of the turbines.
    - The distance at which there are area residents regarding wind turbines.
    - The existing background sound.
  
- Also special care must be taken when selecting a nearby park of where birds live, for the risk of death on impact with the blades, but there are solutions like painting with bright colors the blades, placing the windmills properly leaving "corridors" for the birds, and even in extreme cases to track the birds by radar coming to stop the turbines to avoid collisions.
  - Protected natural areas should be excluded from the development of wind energy.
  
- The construction of parks should be avoided in certain areas such as migration routes and in the living areas of sensitive species or endangered.

- The strength of the wind is not constant and it varies from zero to storm force. This means

that wind turbines do not produce the same amount of electricity all the time. There will be times when they produce no electricity at all.

- When wind turbines are being manufactured some pollution is produced. Therefore wind power produces some pollution.

## ***New wind turbines towers using concrete and steel***

---

The hybrid wind tower is firmly rooted into the ground by the circular ring foundations which are made of in-situ concrete.

The tower is constructed by precast concrete and steel. The concrete is the material found occupying the corners of the tower, shaped quarter circle each part so with the four parties would form a perfect circle. On the other hand, the steel is the material responsible for holding together the structure as it is situated between the concrete parts.

The structure consists of five parts and in the highest part of this continues the rest of the tower which is composed of steel.

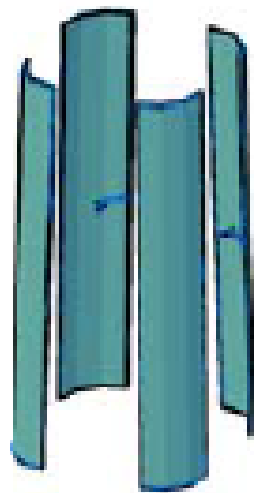

## ***Building process***

---

### **FOUNDATION**

To redirect the loads impinging on the system from the wind and its own weight safely to the ground, the hybrid tower has circle shaped in-situ concrete foundations.

The first step in the construction of the foundation is to remove and stockpile topsoil and subsoil. These soils are separately stockpiled. Upon completion of foundation construction, the soils are replaced in the proper strata.

Foundation is constructed by excavating a hole, placing reinforcing steel and filling the excavation with concrete. The foundation is approximately 18 meters wide and 5 meters deep.

Topsoil and subsoil from the excavation is stockpiled in a semicircle around the foundation.

The next step is to replace the subsoil and then the topsoil over the concrete foundation. Only the center of the foundation remains above the soil surface when grading is complete.

After the foundation construction is complete, the tower will be built.



*The reinforcement of foundation*





*The final foundation*



*The tensors anchors*

## THE HYBRID TOWER

With the help of specially developed assembly devices, the factory-produced concrete ring segments (fourths), which are connected by steel. Once the lowest ring has been calibrated and fixed permanently in place, all of the other rings are simply placed on the top of each other in 'dry joints' without the use of mortar or another smoothing layer. This construction method makes it possible to work almost all year round, also during rainy weather or extremely low temperatures.

The top section of the concrete tower is made of a specially designed ring which as a steel-concrete composite construction, is designed for the connection of the following steel tube tower. This transition section also serves as an upper abutment for the external tendons which run around the interior section of the concrete tower, and which find their second abutment in the stressed base section of the foundations. After the application of the pre-stressing and the anchoring of the pre-stressed cables, the reinforced concrete tower constructed is stable in this way. And then, the steel tower will be placed.



*Prestressed tensioners*

**BUILDING PROCESS**

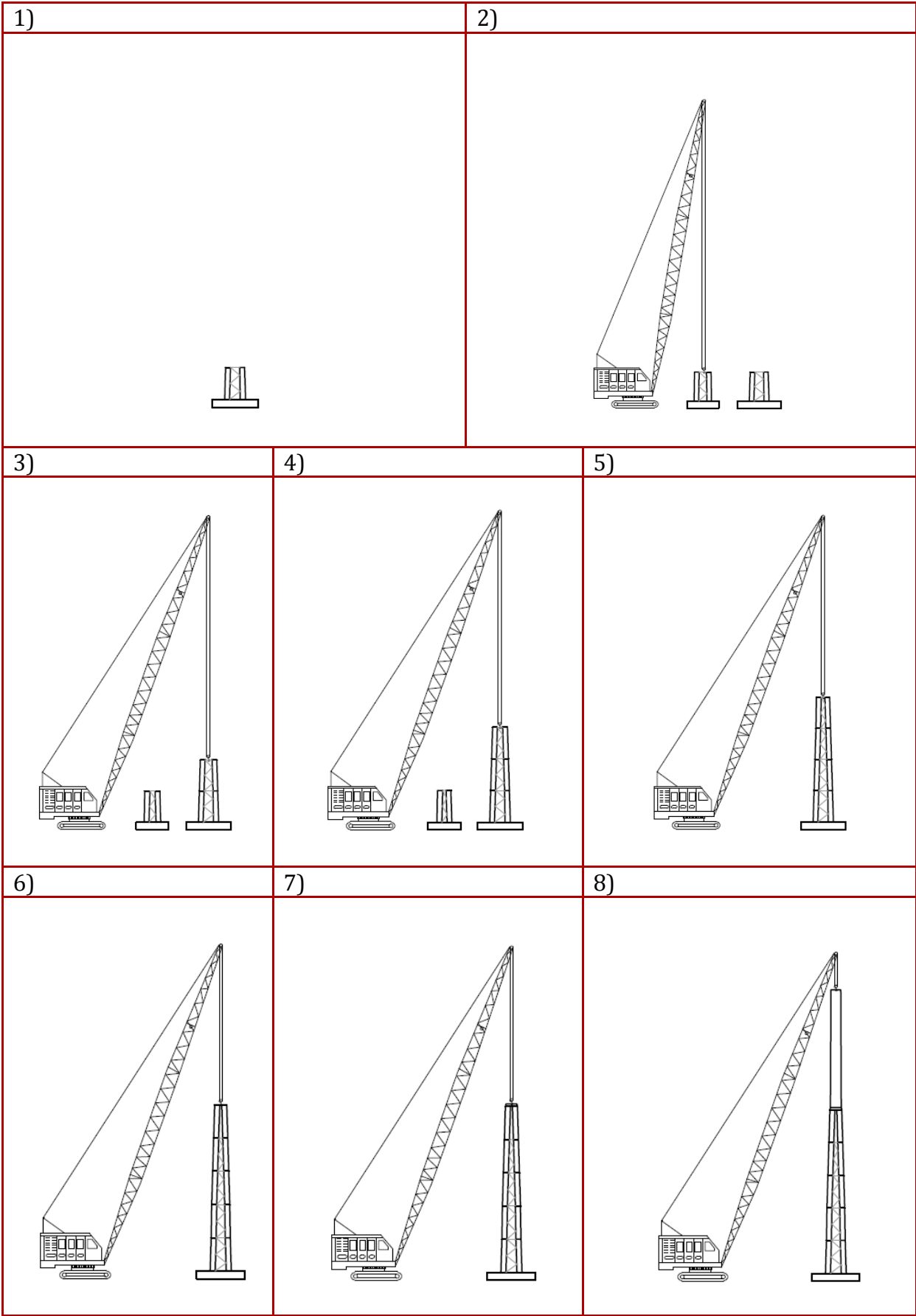

## Calculations

---

### SQUARE TOWER:

### CONCRETE:

in (N/mm <sup>2</sup> )	C30/37
$f_{ck}$	30
$f_{ck, cube}$	37
$f_{cm}$	38
$f_{cd}$	17.0
$f_{ctm}$	2.9
$E_{cm}$	33000
$f_{bd}$ gutter Verbund	3.0
$f_{bd}$ massager Verbund	2.1

Table Eurocode 2

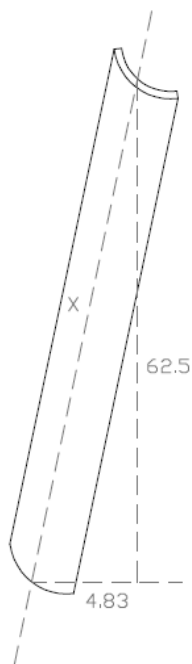

$$62.5^2 + 4.83^2 = x^2$$

$$x = 62.69 \text{ m}$$

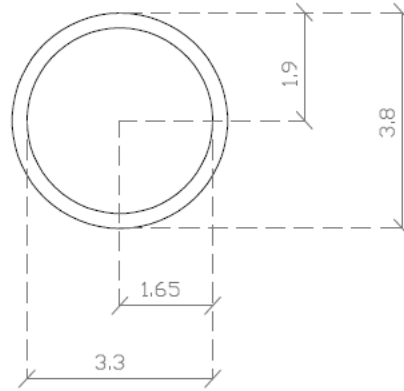
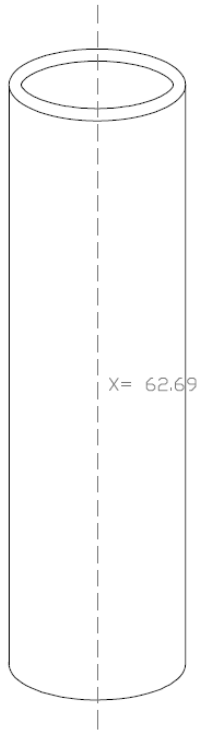

**Formula for the volume:**  $(\pi \times R^2 \times \text{longitude}) - (\pi \times r^2 \times \text{longitude})$

$$\text{Concrete volume} = (\pi \times 1.9^2 \times 62.69) - (\pi \times 1.65^2 \times 62.69) = \boxed{174.79 \text{ m}^3}$$

**STEEL:**

<b>bxh (mm)</b>	<b>t (mm)</b>	<b>A (cm<sup>2</sup>)</b>	<b>I<sub>y</sub>=I<sub>z</sub> (cm<sup>4</sup>)</b>	<b>W<sub>el</sub> (cm<sup>3</sup>)</b>	<b>i (cm)</b>	<b>I<sub>t</sub> (cm<sup>4</sup>)</b>	<b>C<sub>t</sub> (cm<sup>3</sup>)</b>	<b>W<sub>pl</sub> (cm<sup>3</sup>)</b>	<b>M (kg/m)</b>
<b>140</b>	<b>8</b>	<b>41.6</b>	<b>1195</b>	<b>171</b>	<b>5.36</b>	<b>1892</b>	<b>249</b>	<b>204</b>	<b>32.6</b>

*Table Eurocode 3*

**Formula for the volume:** area x longitude

Area = 41.6 cm<sup>2</sup> = 0.00416 m<sup>2</sup>

Longitudes :

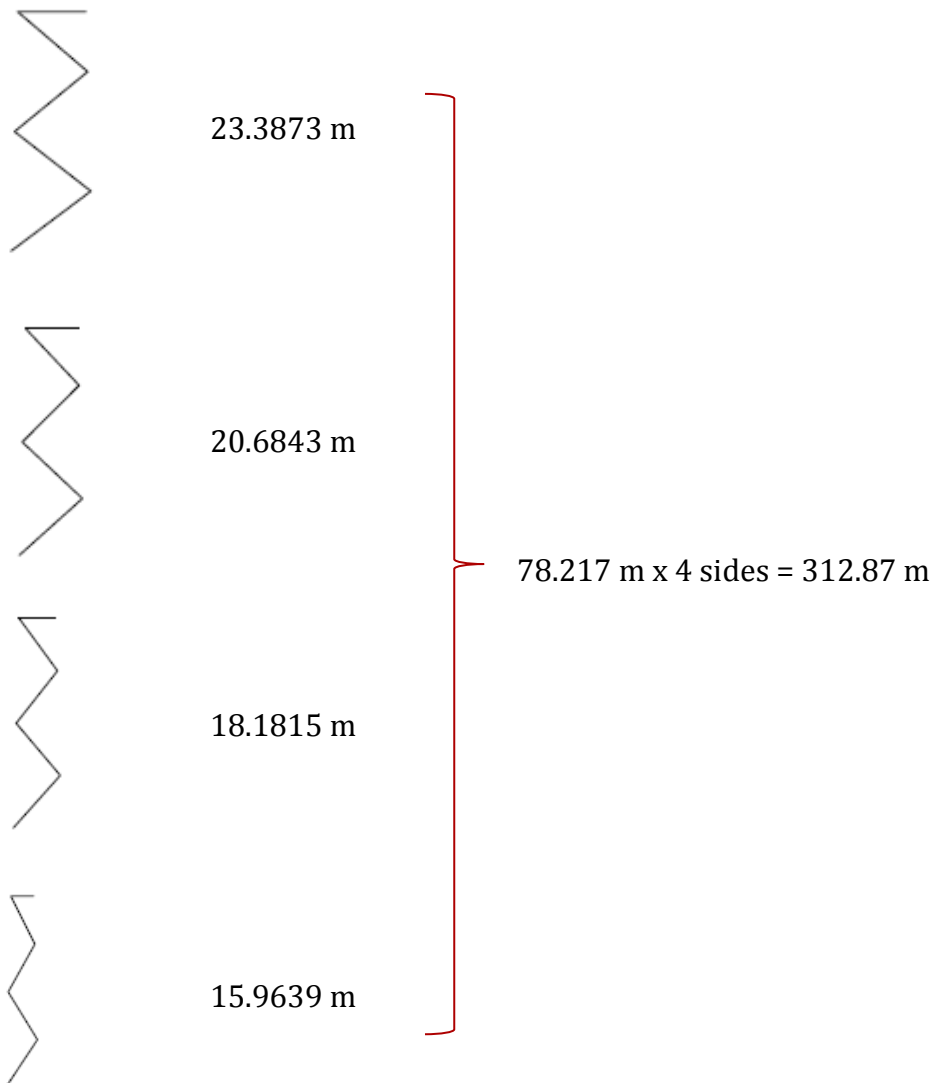

Steel volume = 312.868 x 0.00416 = 1.30 m<sup>3</sup>

## TRIANGULAR TOWER:

### CONCRETE:

in (N/mm <sup>2</sup> )	C30/37
$f_{ck}$	30
$f_{ck, cube}$	37
$f_{cm}$	38
$f_{cd}$	17.0
$f_{ctm}$	2.9
$E_{cm}$	33000
$f_{bd}$ gutter Verbund	3.0
$f_{bd}$ massager Verbund	2.1

Table Eurocode 2

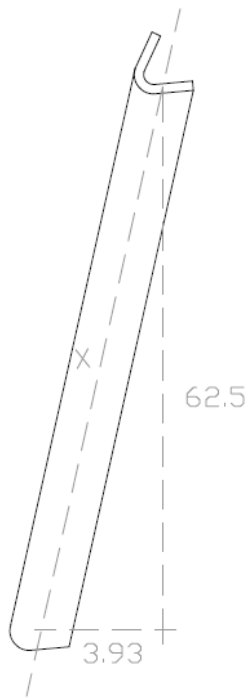

$$62.5^2 + 3.93^2 = x^2$$

$$x = 62.62 \text{ m}$$

Concrete area =  $0.8963 \times 3 = 2.69 \text{ m}^2$

Concrete volume =  $2.69 \times 62.62 = 168.45 \text{ m}^3$

**STEEL:**

<b>bx<b> b</b></b> <b>(mm)</b>	<b>t</b> <b>(mm)</b>	<b>A</b> <b>(cm<sup>2</sup>)</b>	<b>I<sub>y</sub>=I<sub>z</sub></b> <b>(cm<sup>4</sup>)</b>	<b>W<sub>el</sub></b> <b>(cm<sup>3</sup>)</b>	<b>i</b> <b>(cm)</b>	<b>I<sub>t</sub></b> <b>(cm<sup>4</sup>)</b>	<b>C<sub>t</sub></b> <b>(cm<sup>3</sup>)</b>	<b>W<sub>pl</sub></b> <b>(cm<sup>3</sup>)</b>	<b>M</b> <b>(kg/m)</b>
<b>140</b>	<b>8</b>	<b>41.6</b>	<b>1195</b>	<b>171</b>	<b>5.36</b>	<b>1892</b>	<b>249</b>	<b>204</b>	<b>32.6</b>

*Table Eurocode 3*

Area = 41.6 cm<sup>2</sup> = 0.00416 m<sup>2</sup>

Longitudes :

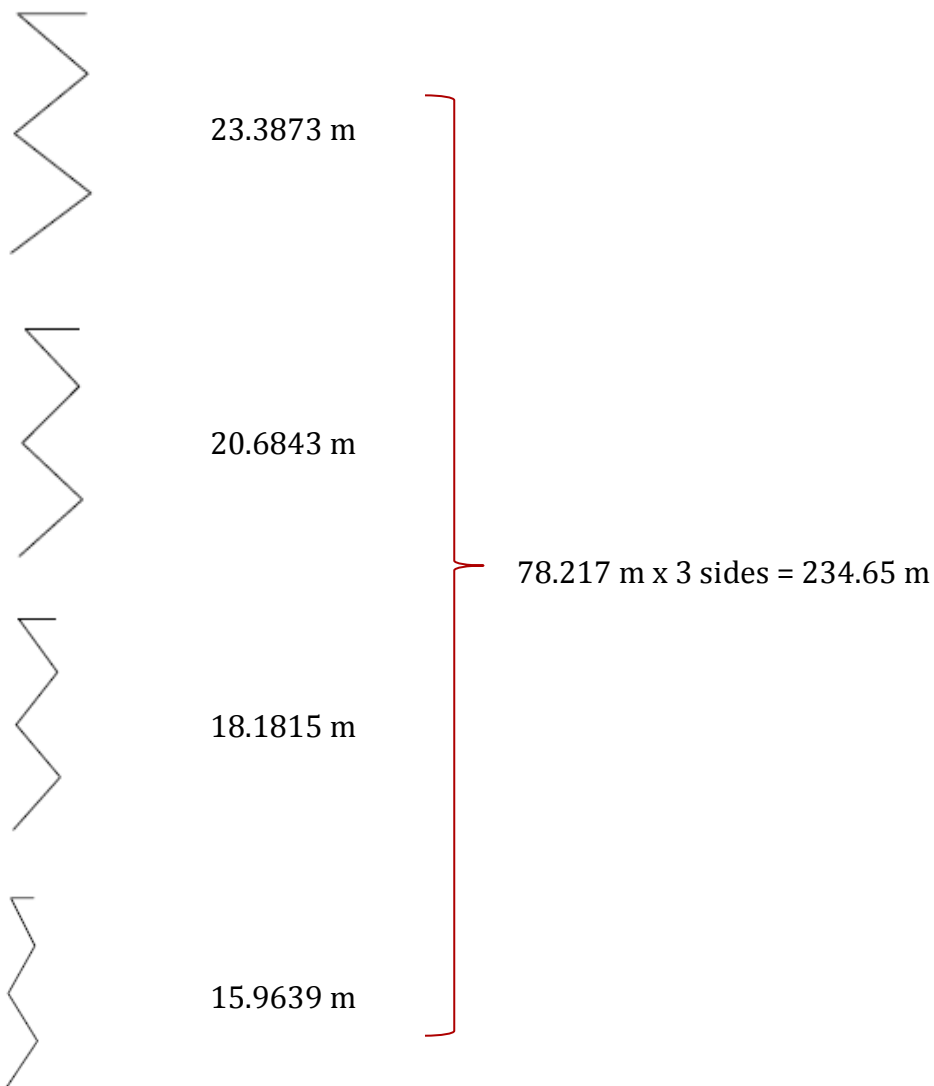

Steel volume = 234.65 x 0.00416 = 0.98 m<sup>3</sup>



## Prices

---

### SQUARE TOWER:

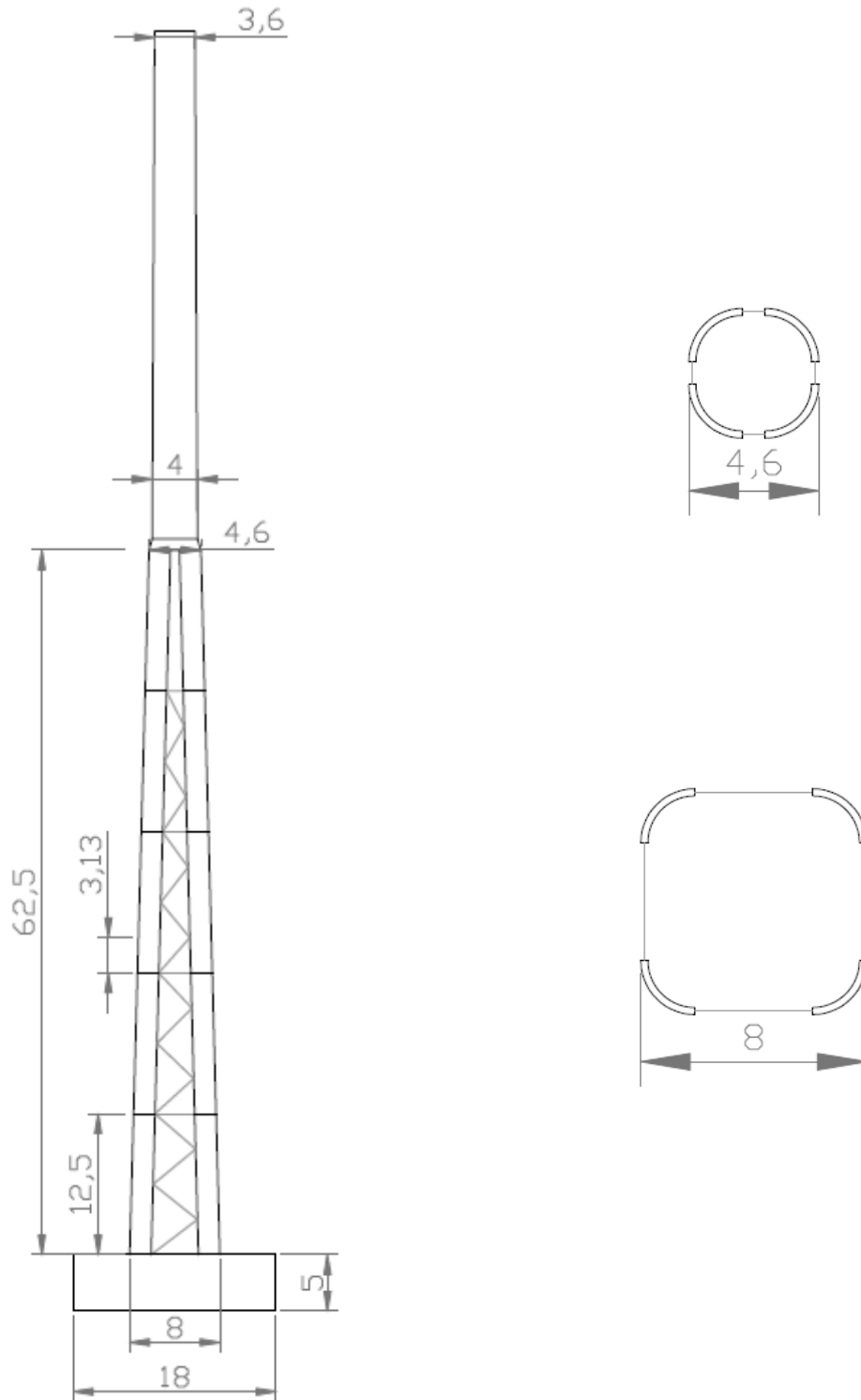

**CONCRETE:**

<b>Designed mixes</b>				
				Aggregate size
				10 mm
				20 mm
				40 mm
	Unit	€	€	€
Grade C30	m <sup>3</sup>	103.34	98.75	102.19
<b>Prescribed mixes</b>				
Add to the above designated mix prices approximately 5.88 €/m <sup>3</sup>				

*Price book table, page 51*

Concrete Volume = 174.79 m<sup>3</sup>

**Price of concrete** = 174.79 x 102.19 = 17861.79 €

Prescribed mixes: 17861.79 + 1027.76 = **18889.55 €**

**STEEL:**

<b>Hot formed structural hollow section</b>	Approx metres per tonne (m)	S355J2H Grande 50D €/100m
140 x 140 x 8.0 mm (32.6)	30.7	3192.7

*Price book table, page 105*

Steel = 312.87 m

**Price of steel** =  $\frac{(312.87 \times 3192.7)}{100} = 9989.46 \text{ €}$

**FORMWORK:**

Item	Gang hours	Labour €	Plant €	Material €	Unit	Total rate €
FORMWORK: FAIR FINISH Curved to one radius in one plane, 0.5 m radius, width 0.2 – 0.4 m	0.9	81.68	12.04	26.14	m <sup>2</sup>	119.86

*Price book table, page 196*

**Formwork price:** 281.07 x 119.86 = **33689.05 €**

**FOUNDATION:**

SUBSTRUCTURE Ground slabs	Unit	THICKNESS OF SLAB		
		2 m	3 m	4.5 m
Mechanical excavation to reduce levels, disposal, level and compact, hardcore bed blinded with sand, 1200 gauge polythene damp proof membrane, concrete 21.00N/mm <sup>2</sup> – 20 mm aggregate (1:2:4) ground slab, tamped finish				
15 m	m <sup>2</sup>	€ 5514.36	6547.79	8529.90
17.5 m	m <sup>2</sup>	€ 5772.13	6823.21	8787.66
20 m	m <sup>2</sup>	€ 5772.13	6823.21	8787.66
Add to the foregoing prices for fabric reinforcement BS 4483, lapped; per m <sup>2</sup> ground floor plan area				
A252 (3.95 kg/m <sup>2</sup> ); 1 layer	m <sup>2</sup>	€ 689.74	689.74	809.79

*Price book table, page 505*

Foundation dimensions= 18 x 18 x 5 m

**Price foundation:** (17.5 x 4.5) = 18 x 5 = **8787.66 €**

**TENSIONERS:**

Item	Gang hours	Labour €	Plant €	Material €	Unit	Total Rate €
<p>The design of prestressing is based on standard patented systems, each of which has produced its own method of anchoring, joining and stressing the cables or wires. The companies marketing the systems will either supply all the materials and fittings required together with the sale or hire of suitable jacks and equipment for prestressing and grouting or they will undertake to complete the work on a sub-contract basis.</p> <p>The rates given below are therefore indicative only of the probable labour and plant costs and do not include for any permanent materials. The advice of specialist contractors should be sought for more accurate rates based on the design for a particular contract. Pretensioned prestressing is normally used only in the manufacture of precast units utilising special beds set up in the supplier's factory.</p> <p>Labour and plant cost in post-tensioning; material cost excluded</p> <p>form ducts to profile including supports and fixings; 60 mm internal diameter</p>	1.00	1.34	3.85	---	m	6.23

*Price book table, page 202*

63 m x 12 tensioners = 756 m

**Price tensioners: 756 x 6.23 = 4709.88 €**

**TRIANGULAR TOWER:**

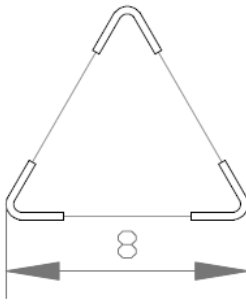
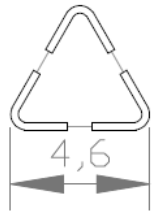
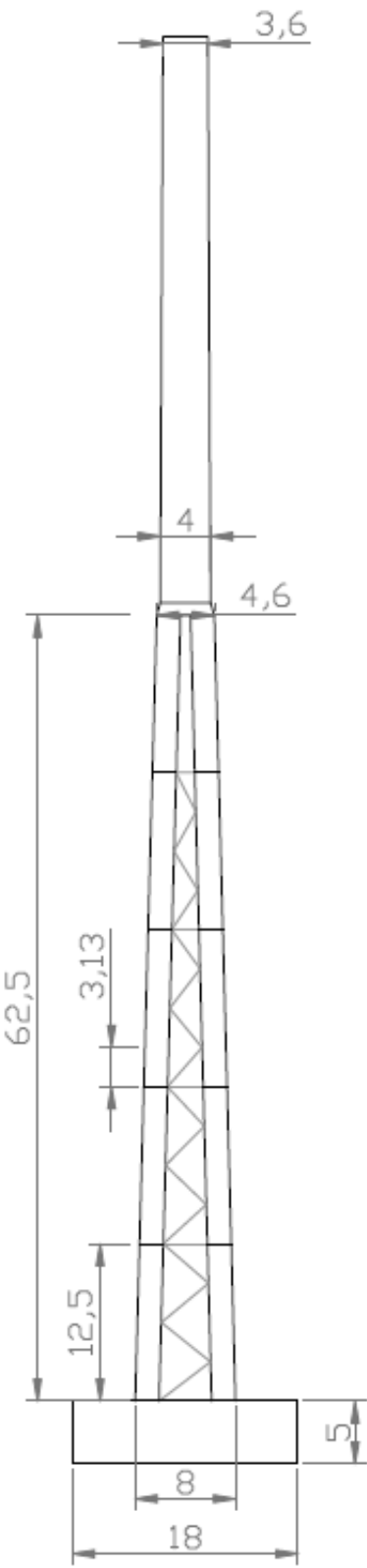

**CONCRETE:**

<b>Designed mixes</b>				
		10 mm	20 mm	Aggregate size 40 mm
	Unit	€	€	€
Grade C30	m <sup>3</sup>	103.34	98.75	102.19
<b>Prescribed mixes</b>				
Add to the above designated mix prices approximately 5.88 €/m <sup>3</sup>				

*Price book table, page 51*Concrete Volume = 168.45 m<sup>3</sup>**Price of concrete** = 168.45 x 102.19 = 17213.91 €Prescribed mixes: 17213.91 + 990.49 = **18204.40 €****STEEL:**

<b>Hot formed structural hollow section</b>	Approx metres per tonne (m)	S355J2H Grande 50D €/100m
140 x 140 x 8.0 mm (32.6)	30.7	3192.7

*Price book table, page 105*

Steel = 234.65 m

**Price of steel** =  $\frac{(234.65 \times 3192.7)}{100} = 7491.67 \text{ €}$

**FORMWORK:**

Item	Gang hours	Labour €	Plant €	Material €	Unit	Total rate €
FORMWORK: FAIR FINISH Curved to one radius in one plane, 0.5 m radius, width 0.2 – 0.4 m	0.9	81.68	12.04	26.14	m <sup>2</sup>	119.86

*Price book table, page 196*

**Formwork price:** 361.87 x 119.86 = **43373.74 €**

**FOUNDATION:**

SUBSTRUCTURE Ground slabs	Unit	THICKNESS OF SLAB		
		2 m	3 m	4.5 m
Mechanical excavation to reduce levels, disposal, level and compact, hardcore bed blinded with sand, 1200 gauge polythene damp proof membrane, concrete 21.00N/mm <sup>2</sup> – 20 mm aggregate (1:2:4) ground slab, tamped finish				
15 m	m <sup>2</sup>	€ 5514.36	6547.79	8529.90
17.5 m	m <sup>2</sup>	€ 5772.13	6823.21	8787.66
20 m	m <sup>2</sup>	€ 5772.13	6823.21	8787.66
Add to the foregoing prices for fabric reinforcement BS 4483, lapped; per m <sup>2</sup> ground floor plan area				
A252 (3.95 kg/m <sup>2</sup> ); 1 layer	m <sup>2</sup>	€ 689.74	689.74	809.79

*Price book table, page 505*

Foundation dimensions= 18 x 18 x 5 m

**Price foundation:** (17.5 x 4.5) = 18 x 5 = **8787.66 €**

**TENSIONERS:**

Item	Gang hours	Labour €	Plant €	Material €	Unit	Total Rate €
<p>The design of prestressing is based on standard patented systems, each of which has produced its own method of anchoring, joining and stressing the cables or wires. The companies marketing the systems will either supply all the materials and fittings required together with the sale or hire of suitable jacks and equipment for prestressing and grouting or they will undertake to complete the work on a sub-contract basis.</p> <p>The rates given below are therefore indicative only of the probable labour and plant costs and do not include for any permanent materials. The advice of specialist contractors should be sought for more accurate rates based on the design for a particular contract. Pretensioned prestressing is normally used only in the manufacture of precast units utilising special beds set up in the supplier's factory.</p> <p>Labour and plant cost in post-tensioning; material cost excluded</p> <p>form ducts to profile including supports and fixings; 60 mm internal diameter</p>	1.00	1.34	3.85	---	m	6.23

*Price book table, page 202*

63 m x 9 tensioners = 567 m

**Price tensioners: 567 x 6.23 = 3532.41 €**



**TOTAL PRICES:**

	<b>SQUARE TOWER</b>	<b>TRIANGULAR TOWER</b>
CONCRETE	18889.55 €	18204.40 €
STEEL	9989.46 €	7491.67 €
FORMWORK	33689.05 €	43373.74 €
FOUNDATION	8787.66 €	8787.66 €
TENSIONERS	4709.88 €	3532.41 €
<b>TOTAL PRICE:</b>	<b>76065.60 €</b>	<b>81389.88 €</b>

## *Conclusion*

---

The renewable energies have been a goal to develop in recent years. These energies are expected to arrive to meet the needs of individuals, providing the saving of other energies more expensive and not as healthy. By far, this is not met by the use of other energies. But over time, these relationships have been increasingly recognized and the industry, the economy and the policy are doing everything possible to change the use of these energies.

Finally, I have to say that people have the most important role in favor of renewable energies, as they are in favor of them. The experts agree in that this first step can not occur without price increases, which will be reduced in the future, benefiting the people in this change.

The wind energy plays the most important role in the renewable energy sector. Due to the constant evolution of technology, the systems are increasingly effective and they are usually used in new installations. Globally, there exist important advances that represent the positive trend of renewable energies, the wind energy industry in particular. Therefore, it is important to develop new ideas and visions.

The wind turbines are being demanded in the buildings that require high energy costs and what it wants to achieve is to be as economically as possible, in order to get a good use of the renewable energies. So, in all the wind energy facilities what is looked for is to achieve greater efficiency.

My role has been to take account of these considerations for the structure of the tower of the wind turbine. Because of this, the aim of this work has been to calculate the quantities of material needed to build a square tower and a triangular tower and once I had this, I had to calculate the prices of the material required in these two hybrid towers.

These are the first steps that we could make when we are designing a wind turbine tower and this can be used to get an idea of the cost. But after, you must take into account many factors such as: the stability of the tower, the rotor weight and all equipment, machinery, transport, staff, ... and the prices of all of this. This could be the continuation of this thesis.

## *Acknowledgements*

---

It is a great pleasure to thank my Spanish advisor, Prof. Isabel Abad Rodriguez, for helping me in everything that I have needed although I was abroad.

Another really great thanks goes to my German advisors, Prof. Jens Minnert and Prof. Wolfgang Moosecker, for having offered me the topic of this thesis and for helping me when I had a problem. I would like also to thank his colleagues Manuel Koob and Daniel Wolff for helping me in this work and for the support that they gave me.

Besides I would like to thank my family, that although they have not been here with me, they have always supported me and they encouraged me to make this Erasmus.

## ***Bibliography***

---

- [www.idae.es](http://www.idae.es)
- [www.appa.es](http://www.appa.es)
- [www.awea.org](http://www.awea.org)
- [www.wikipedia.org](http://www.wikipedia.org)
- [www.opex-energy.com](http://www.opex-energy.com)
- [www.ewea.org](http://www.ewea.org)
- [www.wind-energie.de](http://www.wind-energie.de)
- [www.windpower.org](http://www.windpower.org)
- [www.inersol.es](http://www.inersol.es)
- [www.geolica.com](http://www.geolica.com)
- [www.dewi.de](http://www.dewi.de)
- [www.inneo.es](http://www.inneo.es)
- [www.mbaec.de](http://www.mbaec.de)
- [www.ucsusa.org](http://www.ucsusa.org)
- <http://smienergias.wordpress.com/>
- <http://cer.gob.cl/>
- [www.enercon.de](http://www.enercon.de)
- [www.max-boegl.de](http://www.max-boegl.de)
- Langdon, Davis  
Spon's Civil Engineering and Highway Works Price Book  
Taylor & Francis  
Twenty-third edition  
2009  
Pages 51, 105, 196, 202, 505.