

## THE REFURBISHING OF THE BROTHERHOOD HOUSE AT SANTA LUCIA'S HERMITAGE



ELENA SERRA GARCIA

TITULACIÓN:  
GRADO EN ARQUITECTURA TÉCNICA

ESTUDIANTE:  
ELENA SERRA GARCÍA

TUTORES:  
ENRIQUE DAVID LLÁCER  
JAIME LLINARES MILLÁN

MODALIDAD:  
CIENTÍFICO\_TÉCNICO

FECHA DE PRESENTACIÓN:  
JULIO 2013

## INTRODUCCIÓN

El presente trabajo de Final de Grado en Arquitectura Técnica tiene por objetivo realizar la restauración y conservación de las partes dañadas de la Casa de la Cofradía de la Ermita de Santa Lucía. Esta ermita está situada en la calle Hospital, en pleno centro de la ciudad de Valencia.

Para ello, se han llevado a cabo los siguientes apartados:

En primer lugar, se ha realizado un *estudio histórico* de la época en la que fue construido el edificio, tanto a nivel nacional como a nivel local, y posteriormente a nivel particular.

En segundo lugar, se ha realizado un *estudio fotográfico* de los alrededores y la propia Ermita, para conocer bien todo el edificio.

A continuación, se han levantado los *Planos* necesarios para conocer todos los detalles y medidas.

Posteriormente, en el *análisis compositivo y arquitectónico* y en el *análisis constructivo* se ha estudiado las diferentes zonas del edificio y los materiales y técnicas con las cuales ha sido construido.

Finalmente, tras haber realizado toda esta previa documentación, se da lugar al *estudio de patologías* presentes en las estancias de la cofradía tras varias inspecciones visuales.

Una vez identificadas estas patologías y sus causas, se ha realizado una *propuesta de intervención* de las mismas, siguiendo un criterio conservador en la medida de lo posible, debido a la importancia histórica del edificio.

## INTRODUCTION

This Bachelor Final Project in building engineering is centered in the refurbishment and conservation works of damaged elements at the Santa Lucia's Hermitage Brotherhood House. This Hermitage is paced in the Hospital Street, in the centre of Valencia City.

The complete work is developed throughout the following sections:

First part introduces the *Historical Background* regarding the period when the building was built in national, local and particular settings.

Secondly, it has been made a *Photographic Report* of the surroundings and the Hermitage itself, in order to have an entire perspective of the building.

Thirdly a complete collection of plans is centered in describing every detail and measurements.

Afterwards, in the *Composition and Architectonic Analysis* and the *Constructive Analysis* chapters are studied different areas of the building are studied, as well as the materials and constructive techniques it has been built.

Finally, after analyzing all this previous documentation, the *Pathological Analysis* regarding the damages existing in the Brotherhood Rooms by visual inspections is made.

Once these pathologies and their causes are identified, it has been made an *Intervention Proposal*, following a conservative judgment as far as possible, due to the historical importance of the building.

## INDEX

<b>1. HISTORICAL BACKGROUND .....</b>	<b>6</b>
- National settings .....	8
- Local settings .....	14
- Particular settings .....	16
- Historical evolution of the area .....	18
- Associated documents .....	21
<b>2. PHOTOGRAPHIC REPORT .....</b>	<b>26</b>
- Surroundings .....	28
- Accesses and secondary paths .....	30
- Principal (North) façade .....	32
- West façade .....	33
- South façade .....	34
- East façade .....	35
- Interior of the church .....	36
- Brotherhood House. Ground floor .....	38
- Brotherhood House. First floor .....	39
- Brotherhood House. Second floor .....	41
<b>3. PLANS .....</b>	<b>42</b>
- Sketch floor .....	47
- Principal façade .....	Plan # 1
- South façade .....	Plan # 2
- East façade .....	Plan # 3
- West façade .....	Plan # 4
- Ground floor .....	Plan # 5
- First floor .....	Plan # 6
- Second floor .....	Plan # 7
- Roofs .....	Plan # 8
- A-A' Section .....	Plan # 9
- B-B' Section .....	Plan # 10
- C-C' Section .....	Plan # 11
- D-D' Section .....	Plan # 12
- E-E' Section .....	Plan # 13
- Stairs Detail .....	Plan # 14
<b>4. COMPOSITION AND ARCHITECTONIC ANALYSIS .....</b>	<b>76</b>
- Architectonical settings .....	82
- Areas .....	84
- Communications, mixes and superposition .....	90
- Modules .....	91
<b>5. CONSTRUCTIVE ANALYSIS .....</b>	<b>92</b>
- Basic techniques. Constructive evolution .....	98

- Foundations .....	99
- Structure .....	99
- Walls .....	103
- Roofs .....	105
- Woodwork .....	107
- Singular elements .....	108
<b>6. PATHOLOGICAL ANALYSIS .....</b>	<b>110</b>
- Pathological history .....	112
- Surroundings conditions .....	115
- Damages maps .....	118
- Particular study of damages .....	130
- Damage dossier .....	139
<b>7. INTERVENTION PROPOSAL .....</b>	<b>142</b>
- Intervention criterion .....	144
- Classification of damages .....	144
- Intervention of damages .....	145
- Particular interventions. Intervention project .....	151
- Time chart .....	159
<b>8. CONCLUSION .....</b>	<b>162</b>
<b>9. REFERENCES .....</b>	<b>166</b>
<b>ANNEX: handmade sketches .....</b>	<b>170</b>

## 1. HISTORICAL BACKGROUND



# 1. HISTORICAL BACKGROUND

## NATIONAL SETTINGS

---

The construction of Santa Lucia's Hermitage began in the end of the 14<sup>th</sup> Century (1399 aC). This period was historically known as the last one of the Middle Age, and it was characterized by a European global crisis (it affected economical, political, social and cultural matters).

As far as the economy concerns, it's important to distinguish between agriculture, cattle industry, craftworks and trade. The crisis didn't have the same consequences in all these sectors.

The persistent periods of weather pattern disturbance like droughts, rains in the wrong seasons or exhausted lands, were probably the major cause of the cereal crop decrease. These problems had as a consequence long periods of famine that lead to the Black Death. The countryside experienced a drastic reorganization: the powerful people (the nobles and the clergy) took the lands from the poorest peasants. As a result, the great cereal single crop farming disappeared. It was also created a criminal and poverty environment in the cities, because of the cooperation between beggars who had lost their lands and bandits. Over the last years of the 15<sup>th</sup> Century the olive tree farming became important in the south of the Iberian Peninsula.

The ovine cattle industry became the principal economical source in Spain. The nobility and the middle class found the sheep rearing worthwhile and they reestablished their economy with this activity. Also, because of the different crisis (but mainly due to the Black Death) the rural population drift provided them with crop lands that were transformed into meadows.

The second economical source was the wool trade. The nobility and the army owned great fields to work on, but the most important reason of it was the Hundred Years War. The English exportation was often interrupted, so the Spanish wool took its advantage.

Moreover, the ovine cattle contributed to the economical recovery of Castile. There were trade fairs in commercial places like Medina del Campo, Burgos and Segovia. On the other hand, Castile became a country without industry, where the dominating aristocracy had to get the products manufactured from other countries, and economical activities such as manufacturing disappeared.

Another factor to considerate in this period is the Black Death. It was a terrible epidemic which took place in the middle of the 14<sup>th</sup> Century in Europe. The illness came from the Orient and with symptoms as high fever, headache, shivers and deliriums; it took around 48 hours to be mortal in people. The most populated areas were the ones that suffered more deaths. The population decrease affected the politic life as well, because of the death of almost all the advisers and royal officials. Even king Alfonso XI of Castile died en 1350 of Black Death. In the centre of the country, where the cities were smaller and less populated, the plague had about a 25% of deaths.



Regarding the social life, the less fortunate with the high of the prices were the ones that didn't have means of support. This way, a tense environment where different social groups fought between themselves was created. There were both religious and social class conflicts. The most powerful people intensified their position by pressuring the poorest, returning to the ancient feudal customs.

The crisis was received as a divine punishment for most of the people and because of that, superstitions and religious fanatics became popular. This increased the non-catholic minorities despise, like the Moorish and mainly the Jewish. Until this Century Christians, Jewish and Muslims had lived peacefully and in tolerance, but this events developed into a social separation and Jewish killings.

The throne applicant Enrique assaulted and sacked Jewish quarters with his troops in order to get followers during the Trastámara civil war. He lately tried to reform his politics but the hate was deeply settled in the society. Between the years 1408 and 1412 Hebrews were forced to wear distinctive and forbidden to live among the Christians. There were people who were converted into the Christendom because of the fear, but they practiced their truly religion in secret and maintained their possessions and wealthies. As a result, the hate to de Jewish became a hate for the new Christians. Besides, they had legal rights to marry ancient Christians and hold noble titles.

The 14<sup>th</sup> and 15<sup>th</sup> Centuries were also marked by a politic conflict, which reached its highest level with the Trastámara dynasty. The diagram underneath shows the monarch's succession during this period:

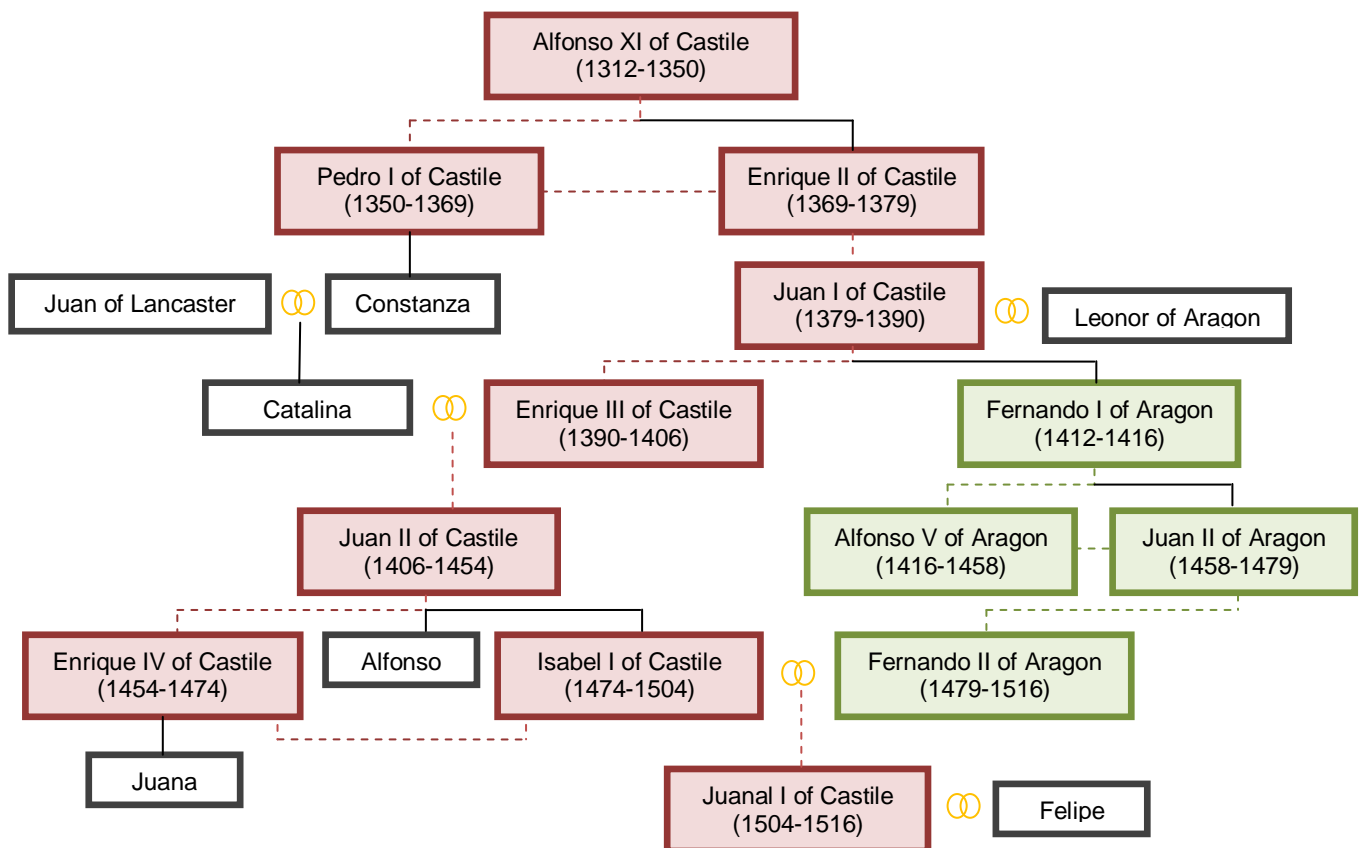

Graphic 1. Monarch's succession during the 15<sup>th</sup> Century

King Alfonso XI began his adulthood in 1325. He made stronger the monarchy power and tried to unificate the cities, but he collaborated with the nobility to get a peaceful kingdom and to fight with the Moors at the Gibraltar strait. This nobility started to apply pressure against the king, but the most affected would be his successors.

King Alfonso XI died prematurely, so King Pedro I was crown at the young age of 16. Because of this, it was necessary to rely on someone to advice the young King, and the old competitions to get the King's favor returned. Juan Alfonso de Alburquerque won, and the losers were Enrique and Fadrique, the King Alfonso XI's illegitimate sons. But there was popular discontent with this election, so when King Pedro I grew up, he decided to govern himself. He gave confidence charges to the oligarchy, merchants and advisers, being most of them convert Jewish. This was economically beneficial to the crown, but the nobles weren't so glad with him.



Picture 1. King Pedro I <sup>(6)</sup>

The nobility was wealthier and claimed more politic power to the monarchy. To achieve it, they conspired against King Pedro I by creating a civil war supporting his brother-in-law Enrique, in exchange for a more powerful nobility and a slightest royal power. Moreover, they were defeated in 1353 and Enrique had to escape to France. After this confrontation, the King eliminated the nobles: the ecclesiastics were removed, the military was given privileges, and more rebel nobles were executed (ever his brother-in-law Fadrique). The enemies named him *Pedro I the Cruel* and the allies named him *Pedro I the Avenging*.

Pedro I decided to take Aragon's crown in 1357 because of his pacts with England. The Aragon power was inferior to Castile's, so French mercenaries commanded by Enrique gave to Aragon their support, in exchange for its help to became Castile's new King. The Aragonese won and crowned Enrique II in Burgos. Despite this, Enrique was defeated by Pedro in Nájera's Battle (1367), due to his troop's reinforcements with English mercenaries. But Pedro's excessive authority was making him lose social support, and the lack of money made him lose the mercenaries as well. Enrique's response was to take a great part of the kingdom. In 1369, his troops defeated Pedro, who was forced to live in Montiel Castle, and lately murdered by an Enrique's trap.



Picture 2. King Enrique II <sup>(7)</sup>

Enrique's reign was characterized by Castile's recovery after the war. He kept satisfied the nobles conceding them what they were promised and relied on the Jewish again. His son and next King Juan I was defeated in 1385 in Portugal, due to his hegemonic pretensions of the entire Iberian Peninsula.

After this unexpected death, King Enrique III was crown in 1390 at the age of 11, which brought instability to the kingdom. When Enrique became adult, he dedicated to continue with his ancestor's polity: reinforce the monarchy and taking power from the nobility. When the King got ill and died in 1406, he named his brother Fernando as his son's Juan II regent. Fernando became the most powerful man in Castile. In 1412 he was elected the King Fernando I of Aragón, but he didn't refuse his obligations as regent in Castile. This way he was able to guarantee his son's future there.



**EL INFANTE DON FERNANDO DE ANTEQUERA**  
(ÓLEO SOBRE LIENZO DEL PINTOR  
DON MANUEL AGUIRRE MONSALVE)  
DIPUTACIÓN PROVINCIAL DE ZARAGOZA

Picture 3. Fernando de Antequera <sup>(8)</sup>

Fernando de Antequera's sons (known as the Aragón's infants) tried to control Castile taking advantage from king Juan II's under age. Their names were Alfonso, Juan and Enrique. Alfonso was Aragón's next King; Juan was Peñafiel's douche, future Navarra king and his brother heir in Aragón's crown; and Enrique was Villena's count and Santiago's Order Grand Master.

While Juan II was supported only by France, the infants were supported by Portugal, England, Aragón, Navarra and an important part of the Castile's nobility. But Juan had the help from a trusting man, Mr. Álvaro de Luna. He became the king's favorite and expelled from Castile the infants in 1430.

Despite his unconditional loyalty to the crown, Mr. Álvaro de Luna didn't always obey the law and he has an arrogant attitude due to his power. That's why the King let himself be influenced and send Álvaro de Luna into exile in 1439.

Therefore, the Aragón's infants attacked Castile in 1443. They took King Juan prisoner, but Mr. Álvaro de Luna returned to beat them in the first of Olmedo's battles. This battled meant the death of one of the infants, Enrique.

Years later, Mr. Álvaro de Luna lost the King's favor again just when he became feeling untouchable, this time under the influence of his second wife queen Isabel of Portugal and Juan Pacheco, who expected Luna's title. He was accused guilty from the King major accountant's death and condemned to death in Valladolid in 1453. Next year King Juan II died, watching how the monarchy gave up power to the nobility.

His successor was crowned as Castile's Enrique IV, who was a King without moral authority and dominated by his entourage. That was the consequence of the noble's annoyance, borne since they were offended by Luna after supporting Juan II in the first Olmedo's battle. Enrique's firsts governing years were prosperous, but he couldn't afford the nobility's demands.

Toledo's archbishop Alfonso Carrillo, Haro's Count, Admiral Mr. Enrique and Santillana's Marquis conspired against him. However, Enrique IV was unable to start a war against them. This weakness took his opponents to organize the Avila's Fake in 1465, where his stepbrother and infant Alfonso was crown at the age of eleven. Castile was plunged again in an anarchy state until Enrique finally decided to fight in the

second Olmedo's battle, in 1467, defeating the noble opponents. One year later, in 1468, infant Alfonso died prematurely. In spite of having the victory in his favor, Enrique showed once again his weak nature by negotiating with the noble opponents, who took their advantage for trying to convince Enrique's stepsister Isabel to take the throne.

Nevertheless, Isabel refused to do it because she didn't want to be controlled by the nobility as her brother Alfonso was. But she made the most of Enrique's lack of personality to convince him of disinheriting his daughter Juana. This way, Isabel would be the first in line to assume the throne. In exchange, Enrique could choose her future husband. All these pacts stayed reflected in the *Toros de Guisando's Treats*, in 1468.

But Isabel had already arranged her marriage with her cousin Fernando of Aragón, son and heir of Juan II of Aragón, and Sicilia's king since 1468. They secretly got married in 1469 without Enrique's permission and after getting a papal bull from Valencian's pope Alejandro VI. When the wedding came out, Isabel's alliance with Aragon was clear. Castile was again threatened by Aragon and a civil war was hard to avoid.



Pictures 4 and 5. The Catholic Monarchs, Isabel of Castile and Fernando of Aragon <sup>(9)</sup>

Guisando's Treats lost their value because of the marriage, so Juana became Enrique's heir again. However, there were rumors about Juana being one of the confident King man's daughter, Beltrán de la Cueva, and people started to call her Juana *la Beltraneja*. Isabel clearly supported these accusations, and when Enrique died in 1474, she proclaimed herself as Castile's Queen.

In the meantime, Juana got married with Portugal's King. This way, the Second Civil War in Castile arrived. On the one hand, there was Isabel, who counted with the support of Aragón, a part of the nobility headed by the Mendoza family, Navarra, England, Burgundy, Brittany and Naples. On the other hand, there was Juana, who counted with the support of Portugal and France. Not only was Castile's throne in play, but the king of monarchy too: Isabel represented an authoritarian and independent monarchy, while Juana represented a weak monarchy with powerful nobility.

Isabel and Fernando were victorious at *Toro's* and *Albuera's* battles, in 1476, and Isabel was recognized as Queen by Madrigal's Courts. In 1479 Fernando's father died and he was proclaimed as the King of Aragón. This way, the united reign of the Catholic Monarchs began, which is considered as the beginning of the unity and glory of Spain.

The Catholic Monarchs introduced some changes in the kingdom to reach their objectives: they created the Holy Brotherhood, a powerful organization that chased those who altered the public comfort, as well as the Royal Council replacing the Courts and naming chief magistrates to control the cities. This way they had control over the entire kingdom. They also created the Inquisition in 1478, an organization that chased the new converted Christians who secretly practiced their old beliefs.

Their next goal was the reconquest of the Muslim kingdom of Granada in 1492, the last Muslim land of the Iberian Peninsula. After their new victory, Isabel and Fernando unified their vassal's religions, they expelled the Jewish and the Muslims who weren't converted to Christianity.

The good political organization and the period of interior peace made the kingdom grow and wealthy. As a result, Isabel could finance Admiral Cristobal Colon's expedition in 1492, in which America was discovered. The kingdom continued growing and getting richer until Isabel's death, in 1504. Fernando took the throne as his daughter Juana's regent, but her husband Felipe of Austria put up resistance and Fernando left to Aragón. Then he achieved the integration of Navarra in the kingdom by marrying his second wife Germana de Foix in 1505. However, because of the early death of Felipe in 1506 and the delicate mental health of his daughter Juana, Fernando returned to Castile as his grandson's Carlos I regent. Carlos I inherited all the territories his grandparents had conquered, and he kept united during centuries as the Spanish monarchy.

## LOCAL SETTINGS

---

After de Christian victory headed by King Jaime I, the Muslin population of the city was expelled and the city was divided among the conquest participants. King Jaime I gave to the city new laws, *els Furs*, which lately were extended along the entire Valencia's kingdom.

In the middle of the 14<sup>th</sup> Century the city suffered the consequences of some events. On the one hand, the Black Death in 1348 and the following epidemics during the next years diminished the population. On the other hand, the city also suffered the consequences of a civic riot against the monarchy's excesses, known as the *Union war*. Finally, between the years 1363 and 1364 Valencia was attacked two times by the Castilians in the war against Castile.



Picture 6. Valencia's coat of arms <sup>(12)</sup>

In order to contain the city during these attacks, Valencians were forced to build a wall around it. As a way to thank the city for its loyalty to King Pedro *e/ Cerimoniós* from Aragon, he gave the city the twice loyal title. It was represented by two *L* as it can be seen in the city's coat of arms.

### Economical background

The Valencian 15<sup>th</sup>'s Century is known as the Golden Century, due to the great economic development as well as the artistic and cultural splendor. The population grew from 4.000 inhabitants at the beginnings of the Century to more than 80.000 inhabitants in 1483.

The *Taula de canvis* was created, a municipal banc that supported the commercial operations. It was also created a local industry which achieved a high development, where the knitting had an special importance. The city became a trade centre where merchants from all over Europe came to. By the end of the Century the *Lonja de mercaderes* was built. It was a transaction centre and a truly business centre.

The economic growth was reflected in the arts and the culture. Some of the most emblematic buildings of the city were built, such as the *Serrano's Towers* (1392), the *Lonja* (1482), the *Miguelete* or the Santo Domingo's Convent King's chapel. As for the painting and the sculpture it was remarkable the influence from Flemish and Italian's artists like *Lluís Dalmau*, *Gonçal Peris* or *Damian Forment*.

On the other hand, the literature flourished as well by authors as *Jordi de Sant Jordi*, *Ausias March*, *Roiç de Corella* or *Isabel de Villena*. By 1460 *Joanot Matorell* wrote *Tirant lo Blanch*, an innovative knighthood novel that influenced many posterior authors, such as Cervantes and Shakespeare.

### Social and politic background

The coexistence in the city between the three religions (such as Christian, Jewish and Muslim) was troubled along the Middle Earth.

The Jewish, who had progressed both economical and socially, were settled around Mar Street. They extended its neighborhood progressively from contiguous churches. On the other hand, the remaining Muslims after King Jaime I's conquest were settled in the Moorish quarter, next to the by then craft Carmen neighborhood and the actual Mosen Sorell market.

In 1391 took place an uncontrolled assault in the Jewish neighborhood. It supposed the community disappearance, as well as the Christianize of more of its members. Nevertheless this forced conversion didn't stop the secret practice of the true religion of most of the converts. Years later, in 1456 took place another popular disturbance. Even though the Moorish quarter was attacked it didn't have serious consequences.

At the end of the 14<sup>th</sup> Century there were also conflicts between the different local patriarchy families. Being separated in two bands, they played an important part in the dynastic dilemma after King Martin the Human's death without descendents. In the sentence, in which the Trastámara family was given the Aragon crown, it's remarkable the brothers Bonifaci and Vicent Ferrer intervention, the last one even became canonized by Calixto III Pope in 1455.



Picture 7. Saint Vicent Ferrer's painting <sup>(13)</sup>

## PARTICULAR SETTINGS

Santa Lucia's Brotherhood is the second brotherhood most ancient in the city. It has its origins a little time after Valencia's conquer by Jaime I of Aragon, in 1238. Those years it was known as the *Almoyna de Santa Lúcia*. The brotherhood's chapel was placed in the ambulatory of the Valencia's Cathedral. This chapel was created in 1276 thanks to Mrs. Constanza de Suabia, King Manfredo of Sicilia's daughter and King Pedro III's wife.



Picture 8. 1965 image with the Hermitage in the forefront <sup>(14)</sup>

The process with the Brotherhood got the Hermitage built is very well documented thanks to the historic member of the brotherhood's testimonies that have been conserved. The land transmissions where the Hermitage was built happened in the following way:

1. By the end of November, 1381, the *Murs i Valls* (walls and valleys) works sub operator Bernat Pérez sold three plots to Pasquala, Bernat Morell's widow. (Parchment #1).
2. In an unknown date Pasquala, Bernat Morell's widow, sold the three plots to Bernat Baro. (Parchment #8).
3. Bernat Baro sold to Jaume Bonet half of one of the plots in 1387 (Parchment #2) and he also sold to Jaume's brother Francesc another plot in an unknown date. (Parchment #8).
4. Francesc Bonet sold his plot to Andreu Luit in an unknown date (Parchment #8), and Jaume Bonet also sold his plot to Leonard Lleopart in March 1391. (Parchment #3).
5. Leonard Lleopart sold in October, 1391, his property to Pere Ponç. (Parchment #4).

In 1392, King Juan II of Aragon approved the chapters by the *Almoyna de Santa Lucia* should be regulated. Years later, in April 1399, King Martin the Human authorized the members of the Brotherhood the construction of the Hermitage. Next October, Bononato Brotons and Pascual Marí bought to Pere Ponç a plot. This plot together with Miguel Morell's and Miguel Bonet's, formed the land the Santa Lucia's Hermitage would rise up to.



The construction began in the year 1400, and it prolonged during more than 100 years, until 1511. In 1517 it was built a Santa Lucía's image that probably is the one placed now in the Brotherhood's *Sala Grande*. Along the 15<sup>th</sup> Century happened two important events in the Hermitage: it was given a papa bull in 1548 by Pope Gregorio XV and it received the visit of Valencia's archbishop's Juan de Ribera in 1570. During the 16<sup>th</sup> Century the Hermitage was enlarged and renewed in the neoclassic style. The most antic elements are the main vault and the presbytery's fleuron.

In 1860, architect Sebastián Monleón Estellés made the principal façade. Five years later, in 1865, Luis Pesetó presented a new design where a belfry was added in the façade. However, until 1925 the façade didn't have its final appearance, after the Lorenzo Criado's architect works.

During the Spanish Civil War, the Hermitage didn't suffer any damages. This is a consequence of an anecdote that tells that Mrs. María Bayo Monferrer, the priest's housekeeper, lived next to the Hermitage and hosted temporarily her French niece Claudia Bayo Gaboyard. Under this pretext, some managements in the consulship were done. There they were given a paper with the following inscription: *here lives a French citizen*. This paper was hanged in the church's door, and this way the Hermitage could save its future in the flames.



Picture 9. The building in the 1960's <sup>(15)</sup>

In 1963, Santa Lucia's Hermitage was declared National Historical-Artistic Monument, and in its façade it can be found a gravestone with the following inscription:

*“Antiga Casa Confraria / de / Santa Llvcia / en les terres adquirides a Bernat Perez i Pasquala / viuda de Bernat Morell el 25 novembre de 1381 Son desde / aquella data on es dona veneracio a la imatge d'aquesta / Verge Martir / fon declarada per decret N 3483 del 28 novembre de 1963 / Conjunt Historic Artistic”*

In the year 2007 it was declared an Asset of Cultural Interest (BIC). Santa Lucia's Hermitage is also subject to the urban regulation *Programa para el desarrollo de la Actuación Integrada de la unidad de ejecución nº4 del suelo urbano de Valencia “Exarchs”: Plan de Reforma Interior de Mejora de la unidad nº4 en el barrio de Velluters (CHP-141) del Plan General de Valencia. Documento nº1: Documentación escrita*, from July 2005.

## HISTORICAL EVOLUTION OF THE AREA

The city of Valencia, as an ancient city with a long history, presents a complex urban evolution. Its urban morphology is divided in different areas that belong with the different periods of the growing of the city: the ancient part of the city, the city expansion and the suburbs.

The *ancient part of the city* is the buildup part since the origin of the city until the 19<sup>th</sup> Century. It has a roman influence and it's placed next to the Mediterranean Sea, in a River Turia affluent. This ancient part was surrounded by a city wall in the Middle Edge. The sketch was irregular and compact in this period, with narrow and tortuous streets and squares without a defined shape. The land uses were residential, industrial and maritime commercial.



Picture 10. Nobilis ac Regia Civitas Valentie in Hispania (1608). Antonio Mancelli <sup>(18)</sup>



Picture 11. Valentia Edetanorum vulgo del Cid, delineata a Dre. Thoma Uincenio Tosca congr. oratorij presbytero (1738 estimated). Tomas Vicente Tosca Mascó <sup>(18)</sup>

Since the middle of the 19<sup>th</sup> Century, it was necessary a *city expansion* because of the population and economical growing of the city. The walls were demolished in 1965 and an exterior circle was created instead, which became the main street of the city. The bourgeoisie expansion was made by the south of the ancient part, inspired on Barcelona's city sketch, with wide blocks and spacious streets. The second city expansion was made in 1907 and extended the city in a third circle, when neighborhoods and near towns (such as Russafa and Campanar) were added to the city.



Picture 12. Tophográfic Valencia del Cid City Plan. Made in 1852 by engineer Mr. Vte. Montero de Espinosa, reduced to the scale 1 pr. 2.500 and enlarged by the constructions and arrangements verified since that date by architect and Sn. Carlos academic teacher Mr. Ramon Ma. Ximenez. Recorded by Anto. Pascual y Abad, editor (1860) Ramón Ma. Ximénez. <sup>(18)</sup>



Picture 13. Valencia's General Map (1925). Anonymous <sup>(18)</sup>

In the second half of the 20<sup>th</sup> Century, the industry and the service sectors experienced a remarkable expansion, so as the immigration. This fact gave place in the *extensive suburbs* where industrial areas were installed. The south of the city was influenced by the change of the river fluent, while the ancient fluent gave the north side of the city great green areas. In the left shore of the ancient river was created a University campus and the new highways to Madrid and Barcelona. The harbor had also become integrated in the city, while the cultivation areas diminished.



Picture 14. Actual sketch of the city <sup>(19)</sup>

## ASSOCIATED DOCUMENTS

---

CONSELLERIA DE CULTURA  
I ESPORT

**PAZ OLMOS PERIS, DIRECTORA GENERAL DE PATRIMONIO CULTURAL  
VALENCIANO DE LA CONSELLERIA DE CULTURA Y DEPORTE DE LA  
GENERALITAT**

**CERTIFICO:**

Que el inmueble denominado Ermita de Santa Lucía sito en la Ciudad de Valencia, Calle Hospital 15 forma parte integrante del Conjunto Histórico Artístico (Zonas del Hospital Viejo) declarado por Decreto 3488/63 de fecha 28-11-1963 (BOE 18-12-1963).

Este conjunto inmueble, declarado Bien de Interés Cultural, ha sido denominado **Recinto del Hospital Viejo y Ermita de Santa Lucía** con la categoría de Monumento, según el decreto 169/2007, de 28 de septiembre, del Consell, *por el que se culmina la primera fase de actualización y adaptación de la Sección Primera del Inventario General del Patrimonio Cultural valenciano con la declaración como Bienes de Interés Cultural de determinados muebles inmuebles* (DOCV nº 5614 de 05-10-2007)

Y para que conste y surta los efectos oportunos expido el presente, a petición de la Cofradía de Santa Lucía, en Valencia a 30 de septiembre de 2008

# REVISIÓN SIMPLIFICADA DEL PLAN GENERAL DE VALENCIA

## CATÁLOGO DE BIENES Y ESPACIOS PROTEGIDOS Ordenación Estructural

### RECINTO DEL HOSPITAL VIEJO Y ERMITA DE SANTA LUCIA

<b>SITUACIÓN:</b> CALLE HOSPITAL, Nº 13 Y 15	<b>BIEN DE INTERÉS CULTURAL</b>
<b>BARRIO:</b> 6- UNIVERSITAT-SAN FRANCESC	
<b>DISTRITO:</b> 1- CIUTAT VELLA	
<b>CÓDIGO:</b> BIC 01. 06. 11	
<b>CATEGORÍA:</b> MONUMENTO	
<b>FECHA DECLARACIÓN:</b> 28.11.1963 [BOE 18.12.1963]	

#### 1. PARCELA:

##### REF. CATASTRAL VIGENTE:

Cartografía Catastral: YJ2752C  
Manzana: 53245  
Parcela: 07, 17, 18  
CART. CATASTRAL: 401-21-III / 423-01-I  
IMPLANTACIÓN: EN ESQUINA DE MANZANA  
FORMA: IRREGULAR  
SUPERFICIE: 15938,06 M2



Fotografía Aérea 2008

#### 2. EDIFICACIÓN:

NÚMERO DE EDIFICIOS: 3  
NÚMERO DE PLANTAS: 2 - Hospital, 3 - Ermita.  
OCUPACIÓN: PARCIAL  
CONSERVACIÓN: REGULAR

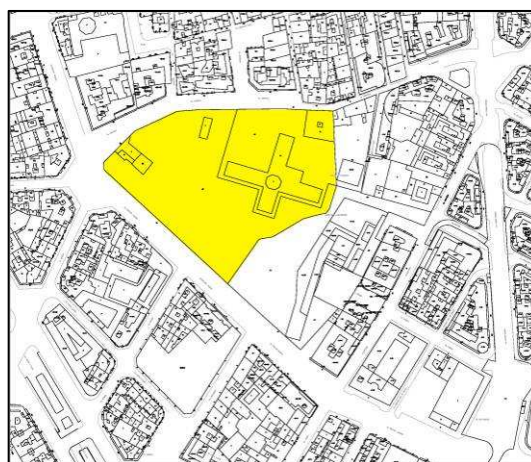

Parcelario Municipal 2008

#### 3. CIRCUNSTANCIAS URBANÍSTICAS Y PATRIMONIALES VIGENTES:

PLANEAMIENTO: PGOU 1988 [BOE 14.01.1989] y en su texto refundido y correc. errores [DOGV 03.05.1993]  
PEPRI Velluters Ad 23.07.1992, [BOP 22.10.1992]  
ED Velluters UA-5 Museo de la Ilustración Ad 29.05.1998 [BOP 30.09.1998]  
MPEPRI Velluters UNIDAD DE EJECUCION Nº17 Ad 29.04.1999 [BOP 14.01.2000]  
MPEPRI Velluters UA 1AR-11BR Ad 27.11.1998 [BOP 05.08.1999]  
MPEPRI Velluters Ad 24.09.2004, [BOP 23.11.2004]

HOJA PLAN GENERAL: C-34  
CLASE DE SUELO: SU  
CALIFICACIÓN: CHP-141. Ciutat Vella Velluters (EL-1) Sistema Local de Espacios Libres

PROTECCIÓN ANTERIOR: PROTEGIDO 1  
OTROS: Nº Archivo: RI1279  
Declarado Conjunto histórico Artístico de carácter nacional, BOE 18.12.1963  
Decreto 169/2007, de 28 de Septiembre [DOCV 05.10.2007].

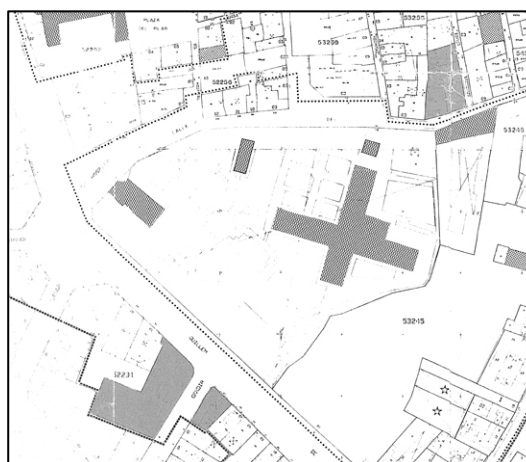

PEPRI Velluters



RECINTO DEL HOSPITAL VIEJO Y ERMITA DE SANTA LUCIA

4. DESCRIPCIÓN Y REFERENCIAS HISTÓRICAS:

Partes integrantes con consideración de BIC:

Antigua enfermería, restos de la "Obra Nova", Capitulo, restos arqueológico-arquitectónicos, incluyendo la iglesia, el tramo de muralla cristiana y los zócalos, portadas, relieves y esculturas de las edificaciones decimonónicas del antiguo Hospital General y de la antigua facultad de Medicina, portada gótica de la primitiva construcción del hospital, ermita de Santa Lucía.

Descripción General:

Es a principios del siglo XV; hacia 1409, cuando se plantea la construcción de un hospital que acogiese a los locos y a los dementes. En 1495 se inició la construcción de la enfermería con planta de cruz griega.

Posteriormente, a mediados del siglo XVII, se levantó otra enfermería en forma de "T": La enfermería realizada en el siglo XVI de estilo renacentista con planta de cruz. Los brazos están divididos en dos plantas cada una de ellas dividida en tres naves por columnas con basas y capiteles decorados y un marcado éntasis. Sobre las columnas se desarrollan bóvedas. En la intersección de los brazos se desarrolla un espacio octogonal sobre el que se eleva una cúpula sobre un alto tambor en que se situaba un altar. Frente a la entrada se encuentra la portada gótica resto del primitivo hospital. Se trata de una portada adintelada con arco apuntado con arquivoltas y un arco conopial formado por un doble alfiz y tímpano vacío con una imagen de la virgen de moderna realización. En la segunda mitad de los años 70 se rehabilitó como Biblioteca Pública.

El capitulo fue construido en el siglo XVIII, en 1730, por la Cofradía de Nuestra Señora de los Inocentes Mártires y Desamparados. Es un pequeño edificio que servía tanto como oratorio como sala de reuniones del Capítulo de la cofradía. Tiene planta rectangular y con una fachada con remate mixtilíneo y una espadaña de pequeño tamaño en el centro.

La Ermita de Santa Lucía se sitúa en el extremo más cercano a la calle Guillem de Castro. Es la sede de la Cofradía de Santa Lucía que fue creada a finales del siglo XIV. Su construcción es incierta aunque se conservan restos medievales en la capilla mayor como son los nervios de una bóveda. El edificio que se conserva es de estilo barroco. De una sola nave rectangular con capillas laterales, cinco a cada lado. La nave está cubierta con bóveda rebajada con lunetas en los que se abren ventanas. En la planta superior de la ermita se encuentra la sala de juntas, que en la actualidad es museo. La fachada es muy sencilla con una hornacina con el busto de la santa titular y una espadaña en la parte superior.

En los jardines habilitados como envolvente de la Biblioteca Pública, se conservan, descontextualizadas, numerosas piezas arquitectónicas de cantería -basas, columnas y capiteles, en particular- que, pertenecientes a la enfermería nueva (l'Obra Nova), forman falsos patios o constituyen de manera dispersa, detalles arqueologizantes en caminos y parterres. También subsisten sus trazas y otros restos en el subsuelo, además de los recientemente exhumados.

En el siglo XIX se instaló junto al hospital la Facultad de Medicina según proyecto de Sebastián Monleón de 1875 y realizada por Antonio Martorell en 1886.

Observaciones:

El ajardinamiento y tratamiento general del recinto merece una revisión crítica que armonice modernidad y funcionalidad con rigor arqueológico, legibilidad arquitectónica y consecuente puesta en valor del conjunto

(Decreto 169/2007, de 28 de septiembre. DOGV 05.10.07 Número 5614)

Hospital: En 1969 lo cedió la Diputación para la Casa de Cultura que se instaló en 1979 en la antigua enfermería, tras su reforma, ajardinándose el resto de la manzana por la que se esparcieron restos de los derribos.

Ermita: En 1865 el maestro de obras Luis Peseto, junto a José Mustieles, levantó un campanil sobre la primitiva fachada, y en 1925 se reformó la fachada según proyecto de Lorenzo Criado. En 1979 se realizaron obras de restauración y conservación.

(Guía de Arquitectura de Valencia)

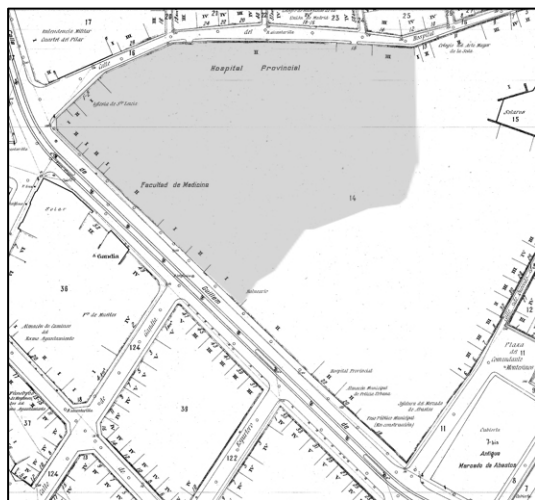

Cartográfico Municipal 1929-1945



Cartográfico C.G.C.C.T 1980



RECINTO DEL HOSPITAL VIEJO Y ERMITA DE SANTA LUCIA

5. REFERENCIAS TÉCNICAS:

AUTOR DEL PROYECTO: --

FECHA DE CONSTRUCCION: Ermita y Hospital: s. XVI; Capitulo: s. XVIII

SISTEMA CONSTRUCTIVO:

CAPITULET: Tiene planta rectangular y con una fachada con remate mixtilíneo y una espadaña de pequeño tamaño en el centro. Sistema Sustentante: Bóveda de medio cañón.

HOSPITAL: La enfermería realizada en el siglo XVI de estilo renacentista con planta de cruz. Los brazos están divididos en dos plantas cada una de ellas dividida en tres naves por columnas con basas y capiteles decorados y un marcado éntasis. Sistema Sustentante: Predominan los abovedamientos.

ÉRMITA DE SANTA LUCÍA: Una sola nave rectangular con capillas laterales, cinco a cada lado. Sistema Sustentante: Bóveda rebajada sobre arcos fajones.



6. VALORES PATRIMONIALES:

Valoración urbanística:

- Valor ambiental
- Integración Urbana
- Carácter articulador
- Carácter estructural

Valoración arquitectónica:

- Adscripción tipológica
- Carácter modelo referencia
- Ref. cultural-arquitectónica

Valoración socio-cultural:

- Referencia histórica

Valoración pormenorizada:

- Fachada principal
- Fachada trasera o lateral
- Cubierta
- Estructura espacial interna
- Cúpula
- Restos arqueológicos del jardín
- Antigua puerta de acceso
- Pinturas murales de la ermita





RECINTO DEL HOSPITAL VIEJO Y ERMITA DE SANTA LUCIA

7. ENTORNO DE PROTECCIÓN:

Delimitación del entorno afectado:

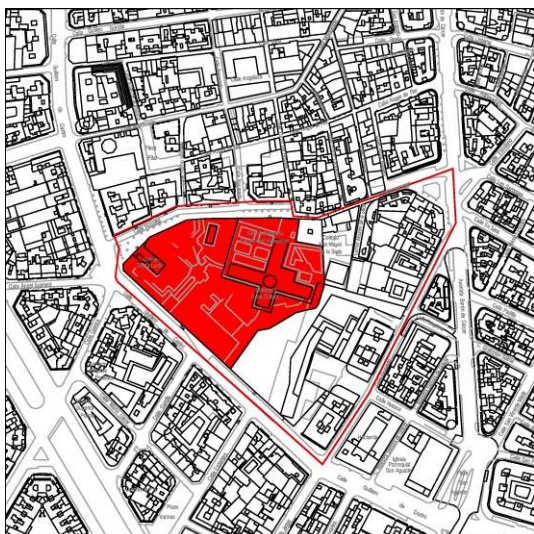

Descripción de la línea delimitadora:

Origen: Intersección del eje de la calle Guillem de Castro con el de la calle Quevedo.

Sentido: Sentido antihorario.

Línea delimitadora: Desde el origen la línea sigue por el eje de la calle Quevedo hasta continuar por el de la calle Barón de Carcer y el de la calle Del Hospital. Del cual incorpora todo su espacio público, siguiendo por las fachadas de las edificaciones perimetrales que recaen sobre esa calle, hasta intersectar con el eje de la calle Guillem de Castro que sigue hasta el punto de origen.

(La delimitación del entorno de protección se acoge a lo dispuesto en el Apto.1 de la Disposición Transitoria Primera de la ley 5/2007 modificadora de la 4/1998. Esta delimitación queda reconocida con carácter provisional según la delimitación contenida en el Anexo 3 del Catálogo de Bienes y Espacios Protegidos del PGOU de Valencia de 1988- con arreglo a lo establecido por el "Convenio Marco de Colaboración entre la Generalitat Valenciana y el Ayuntamiento de Valencia para el Desarrollo y Ejecución del Planeamiento Urbanístico del Conjunto Histórico de la Ciudad" suscrito el día 22 de junio de 1994 y publicado en el DOGV de 04/11/1994)

Delimitación del entorno de protección: Declarado BIC, Decreto 169/2007, de 28 de Septiembre [DOCV 05.10.2007]. Entorno compartido con el BIC Colegio de arte mayor de la seda y su huerto.

8. RÉGIMEN DE INTERVENCIÓN:

- Conservación
- Restauración
- Eliminación de elementos impropios
- Reposición de elementos primitivos
- Reforma y redistribución interior

Condiciones:

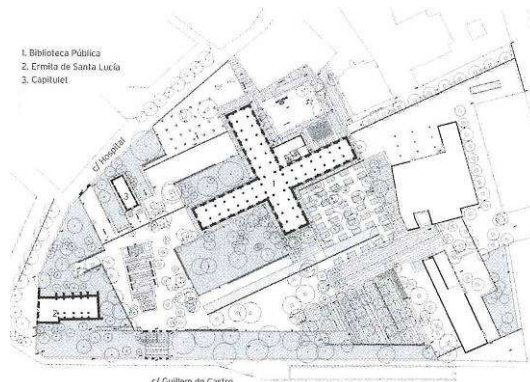

9. NORMATIVA DE APLICACIÓN:

10. REFERENCIAS BIBLIOGRÁFICAS:

- Decreto 169/2007, de 28 de septiembre. DOGV 05.10.07 Número 5614.
- Ficha BIC's de la web de la D.G. de Patrimoni Cultural Valencià. Conselleria de Cultura i Esport. [http://www.cult.gva.es/dgpa/Bics/listado\_bics.asp]. Consulta 26.03.2010
- A.A.V.V.: "Catálogo de monumentos y conjuntos de la Comunidad Valenciana". Conselleria de Cultura, Educació i Ciència.Valencia.1983.
- A.A.V.V.: "Guía de arquitectura de Valencia". CTAV. Valencia 2007.
- A.A.V.V.: "Monumentos de la Comunidad Valenciana. Catálogo de Monumentos y Conjuntos declarados e incoados. Tomo X. Valencia. Arquitectura Religiosa". Conselleria de Cultura, Educació i Ciència. Valencia 1995.

11. OBSERVACIONES:

Situación:

- Capitulet: Calle Guillem de Castro 16
- Ermita de Santa Lucía: Calle del Hospital 15
- Hospital Viejo: Calle del Hospital 11

El Ayuntamiento de Valencia, de conformidad con la Ley de Patrimonio Cultural Valenciano, ha iniciado la redacción y tramitación del Plan Especial de Protección de este Bien de Interés Cultural. El Plan Especial podrá, en su caso, afectar al contenido de esta ficha.



## 2. PHOTOGRAPHIC REPORT



## 2. PHOTOGRAPHIC REPORT

### SURROUNDINGS

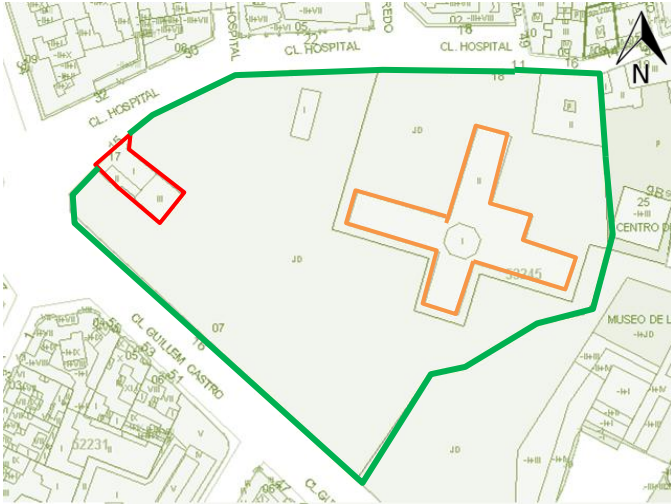

Graphic 2. Hermitage placement (red) and surroundings (green), where the Municipal Library (orange) is located



Picture 15. Gardens with Roman ruins



Picture 16. Municipal Library and former General Hospital behind Roman ruins



Picture 17. Esculapio sculpture, by the Valencian's artist José Aixa



Picture 18. Old Medicine Faculty door front view



Picture 19. Hermitage view from Guillem de Castro Street



Picture 20. Square with a fountain in the North Façade



Picture 21. North Façade access by the square



Picture 22. Gardens at the East side of the Hermitage



Picture 23. Gardens at the East side of the Hermitage



Picture 24. Open area with roman ruins at the South side of the Hermitage



Picture 25. Open area with roman ruins at the South side of the Hermitage

## ACCESSES AND SECONDARY PATHS



Picture 26. Main door in the North Façade

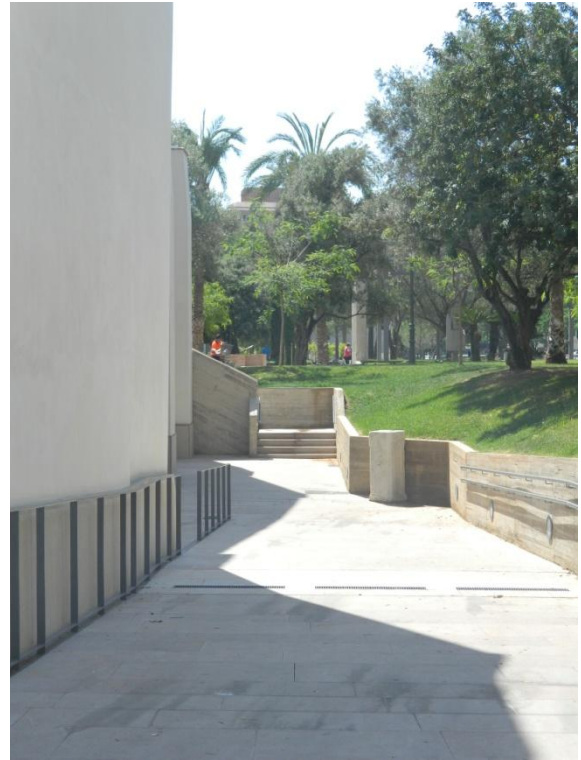

Picture 27. Lateral access at the West Façade



Picture 28. Door in the West Façade. Accessible entrance

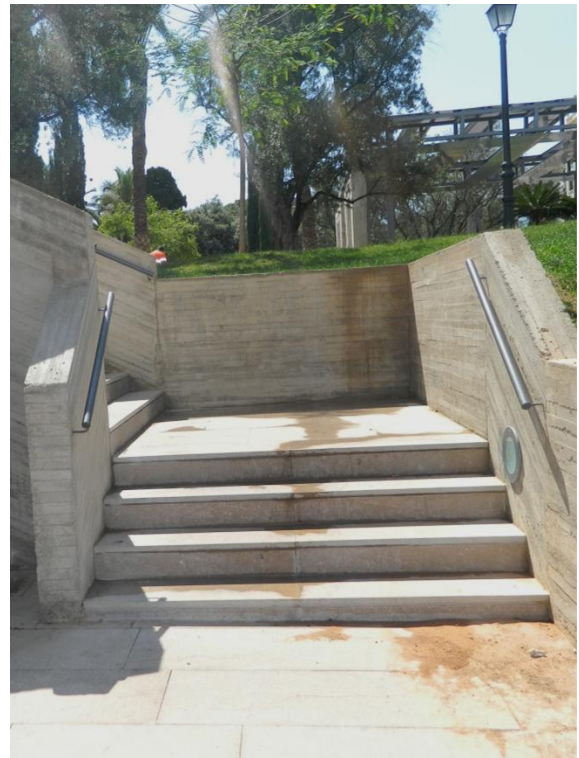

Picture 29. Stairs in the West Façade, communicating with the South Façade



Picture 30. Hermitage access at the North Façade



Picture 31. Lateral and access to the lateral nave



Picture 32. Lateral nave with an entrance to the Brotherhood House at the end

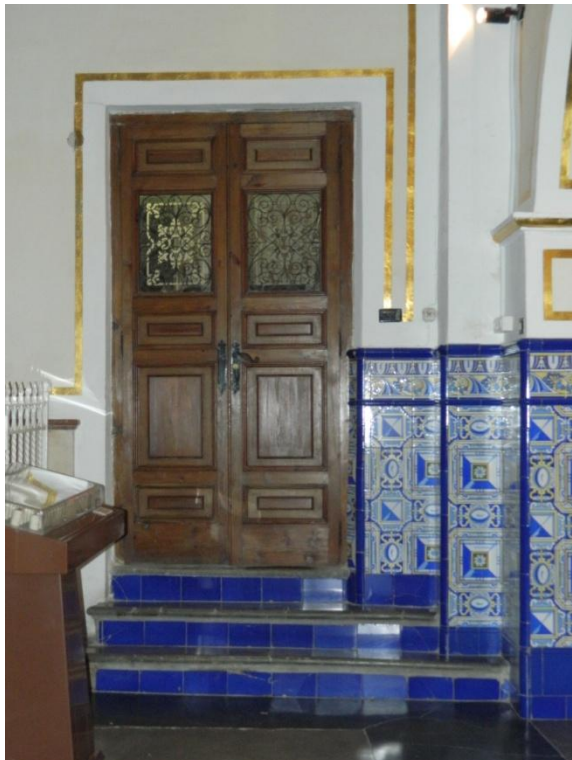

Picture 33. Entrance to the Brotherhood House from the interior of the Hermitage

## PRINCIPAL (NORTH) FAÇADE



Picture 34. North Façade frontal view



Picture 35. Santa Lucia terracotta figurine in a niche under the two bells, *Santa Lucia* (1786) and *Santa Águeda* (1872)



Picture 36. Lateral corridor at the right side of the North Façade



## WEST FAÇADE



Picture 37. West Façade view with the lateral corridor and the stairs to the South Façade



Picture 38. West Façade's left side view



Picture 39. West Façade's central part view



Picture 40. West Façade's right side view

## SOUTH FAÇADE



Picture 41. South Façade's corner with the West Façade



Picture 42. South Façade's corner with the East Façade



Picture 43. South Façade's niche placement



Picture 44. Niche with a *Virgen con el niño* figurine, from the 19<sup>th</sup> Century

## EAST FAÇADE



Picture 45. East Façade frontal view



Picture 46. East Façade's lateral corridor

## INTERIOR OF THE CHURCH



Picture 47. Principal nave's frontal view, with the barrel vault on the top and the Gothic vault at the end



Picture 48. Principal baroque altarpiece

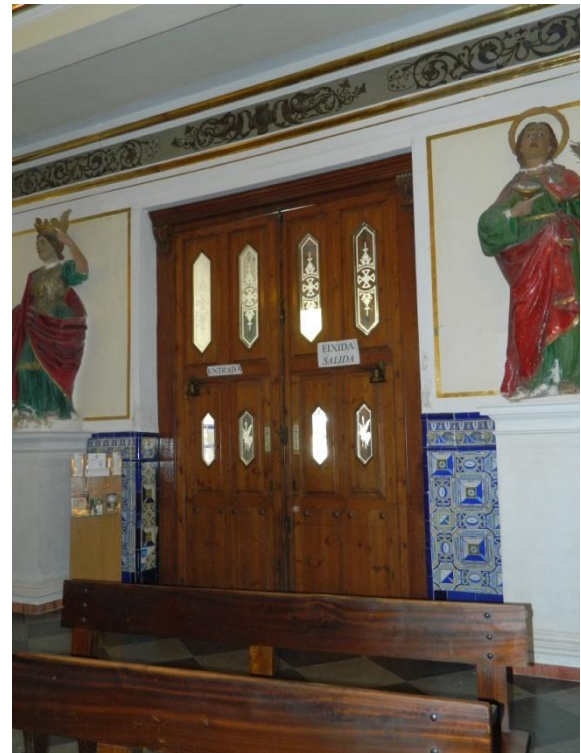

Picture 49. Entrance door by the North Façade



Picture 50. Baroque altarpieces in the right side of the principal nave



Picture 51. Arcade communicating the principal nave with the lateral nave



Picture 52. Lateral nave with the sacristy at the end

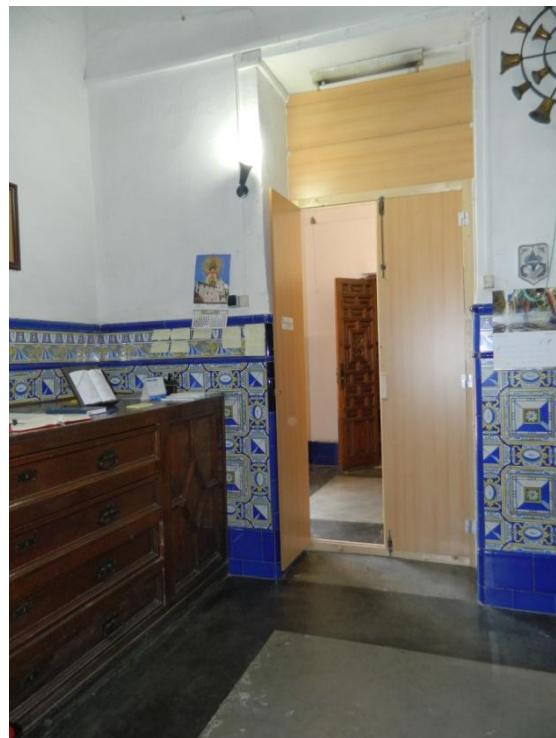

Picture 53. Sacristy, placed next to the altar

## BROTHERHOOD HOUSE. GROUND FLOOR



Picture 54. Door that communicates the Hermitage with the Brotherhood House



Picture 55. Brotherhood House Entrance Room from the North Façade



Picture 56. Lateral view of the Entrance Room, which communicates with the stairs and a toilet



Picture 57 Access to the stairs



Picture 58. Stairs to access to the first floor

## BROTHERHOOD HOUSE. FIRST FLOOR



Picture 59. Small Terrace



Picture 60. Kitchen's general view



Picture 61. Former Dining-Room's general view



Picture 62. Toilet's general view



Picture 63. Corridor 2's general view



Picture 64. Room 1's general view



Picture 65. Study's general view



Picture 66. Room 2's general view



Picture 67. New Meeting Room's general view



Picture 68. Corridor 1's general view



Picture 69. Stairs to the Second Floor



## BROTHERHOOD HOUSE. SECOND FLOOR



Picture 70. Stairs to the Second Floor



Picture 71. Bell Founder Archive (Sala del Gat)



Picture 72. Room 3



Picture 73. Big Room (Sala Grande)

## 3. PLANS



### 3. PLANS

Plans are a very important part in a refurbishing process, because they give all the graphic information about the building that is being intervened. That's the reason why it's important to elaborate them well, so below there are explained new and traditional methods for making the plans in Cultural Heritage: the empirical, topographic, laser scanning and photogrammetry techniques.

The *empirical technique* is the one used in the present project. In this method, measurements are taken of distances between characteristic points on the surface of the monument. In this case, these measurements have been taken with the help of a laser, triangulating directly from the façades and the surfaces.



Picture 74. Laser used in the measurement <sup>(24)</sup>

The method is simple and productive, portable and of low cost. On the other hand it is of low accuracy and demanding in terms of time of physical presence near the monument. It can be successfully applied when a monument has simple shape, or there is a need for recording a sectional plan or sections of interiors.

The *topographic method* implements a 3D orthogonal coordinate system by using complicated and high-accuracy measuring devices. Mainly, this method uses a Geodesic Station, a system for measuring angles and distances of characteristic points on the surface of the monument, which are transformed to coordinates in reference to the initial orthogonal coordinate system.

The main advantage of the method is its high accuracy and objectivity of the measurements. It is reliable and it is easy to process its results. A disadvantage is the need for long physical presence near the monument, but it is one of the only methods to be used under difficult conditions, such as complex shape and difficult access.



Picture 75. Geodesic Station <sup>(25)</sup>

*Laser scanners* can actually be considered as advanced geodesic stations and can be used to measure topographic quantities. They can measure the direction of a fictional optical line joining the characteristic points on the surface of the monument to a reference point on the measuring device (as we can see in the picture). Additionally these scanners can estimate their distance from these points. By applying the triangulation they produce Cartesian coordinates automatically.

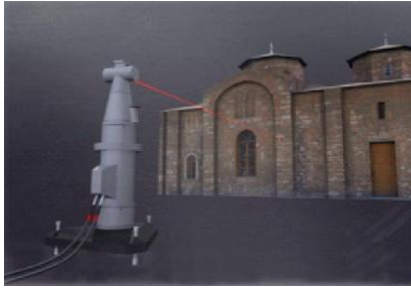

Picture 76. Laser (range) scanning of monuments <sup>(20)</sup>

Their main advantage is the high accuracy and productivity, as well as the large volume of measurement data produced. It is reliable and objective. On the other hand it is a method of high cost and difficulties in portability and autonomy. It can be applied on almost every monument digitization, but can experience interference from bright lights.

Common digital photos can be used for measurements that can be of the accuracy obtained by the topographic methods. By applying orientation processes and transformations of digital *photogrammetry* it is possible to deduce 2D or 3D coordinates from one or two photos.

The method is objective and reliable and can be aided by CAD software. It is relatively simple and has low cost. On the other hand it has to be combined with topographical or empirical measurements, and the final outcome is a function of the time spent.

It can be used for complex objects with high surface detail, but since it is based on photos, there is a need for adequate space. It is also useful when direct access or contact to the monument is prohibited.



Picture 77. Photogrammetry example in architecture <sup>(26)</sup>

One example of this method was carried out for the documentation of the Al-Khasneh monument in Petra city, Jordan.

For the point collection was applied the 3D laser scanning system GS100. The scanning range of the system allows distance measurements between 2 and 100 meters and is able to measure 5.000 points per second. During data collection, a calibrated video snapshot is additionally captured, which is automatically mapped to the corresponding point measurements. In addition to the laser data, digital images were captured for photogrammetric processing.

Three different viewpoints with five scans were done to resolve the occlusions. All the acquired 3D models have been processed using Innovmetric Software, PolyWorks. The model of Al-Khasneh facade resulted from merging the five scans in an independent coordinate system into an absolute coordinate system. After registration of the scans using corresponding points, the software constructs a surface representation.

In spite of using this method, it's still difficult to recognize and localize the outlines of the surface features. As it can be seen in this picture, the cracks and the edges outlines are lost beyond the resolution in the available laser data. In order to support the visual quality of such details, a hybrid combining data from the laser

scanner and the digital imagery was developed. After position and orientation parameters are computed for the sensor stations, distance images are generated in order to provide the missing third dimension in the available images. Finally, an integrated segmentation process based on the image data is used in order to support the extraction of the details and the surface features outlines from distance images. An algorithm transforms the 3D straight lines extracted from the laser data and the corresponding 2D image lines, which are given by two points, into a parameterized representation, which we can see in the image below.

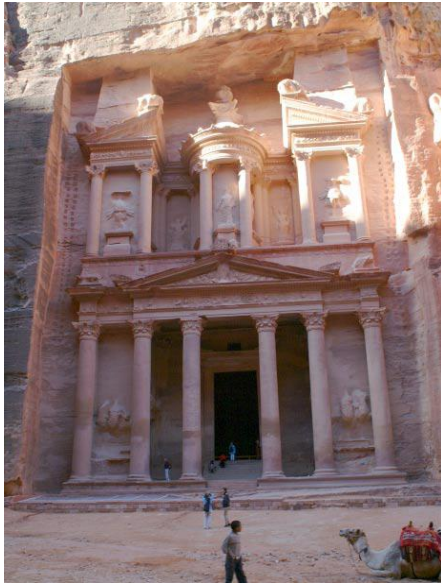

Picture 78. Al-Khasneh facade, Petra <sup>(22)</sup>

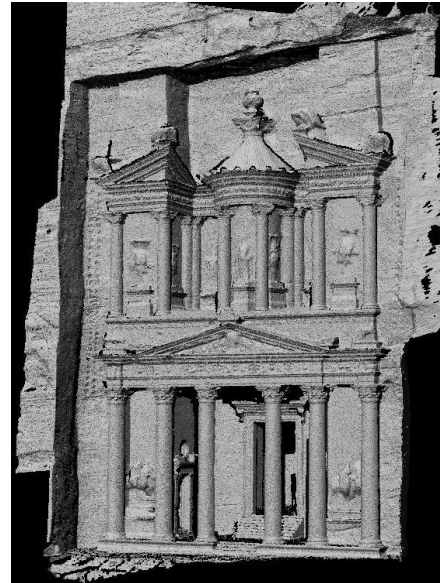

Picture 79. 3D Model of Al-Khasneh created from 5 scans <sup>(22)</sup>

## SKETCH FLOOR

### GROUND FLOOR

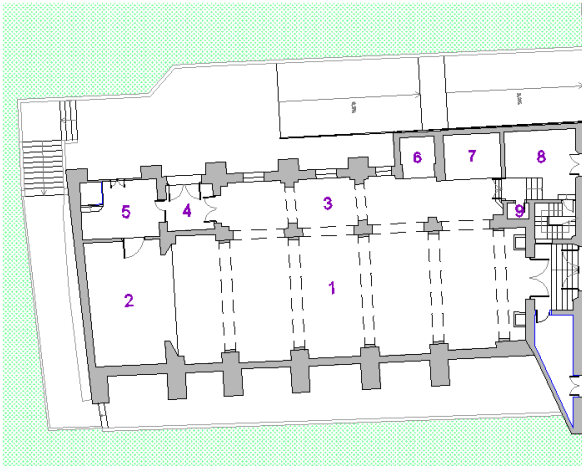

Graphic 3. Ground Floor

In the Ground Floor is placed the church and the entrance to the Hermitage House. The church is composed by a *principal nave* (1) with a *presbytery* (2) at the end and a *lateral nave* (3). Preceding this lateral nave, there's a *hall* (4) which gives access to the *sacristy* (5). On the right side of the lateral nave there are also *two chapels*, named as the *Santísimo Cristo del Perdón's chapel* (6) and the *Santa Águeda's chapel* (7). Next to this last chapel, the entrance to the Brotherhood House is placed, by a *Public room* (8), where there's also a *toilet* (9).

### FIRST FLOOR

In the first floor there are placed a great part of the Brotherhood Rooms. They are comprised by two terraces, a *Big Terrace* (10) and a *Small Terrace* (15). The *Corridor 1* (21) gives access to a *Choir* (11) and a *Former Dining-Room* (12), communicated with a *Toilet* (13), a *Kitchen* (14) and the *Corridor 2* (17). This second corridor leads to the *Room 1* (16), and a *Study* (18). Right after, there're the *Room 2* (19) and the *New Meeting Room* (20).

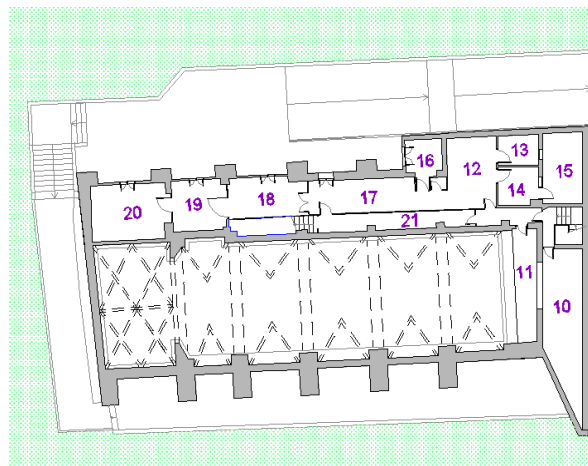

Graphic 4. First Floor

### SECOND FLOOR

In the third floor, there are placed the rest of the Brotherhood Rooms. After going up the stairs, there are placed the *Room 3* (22), the *Bell Founder Archive* (23), which gives access to a *Study* (24) and the *Former Meeting Room* (25). Right after, there's placed the *Big Room* (26), which contains a *Closet* (27).

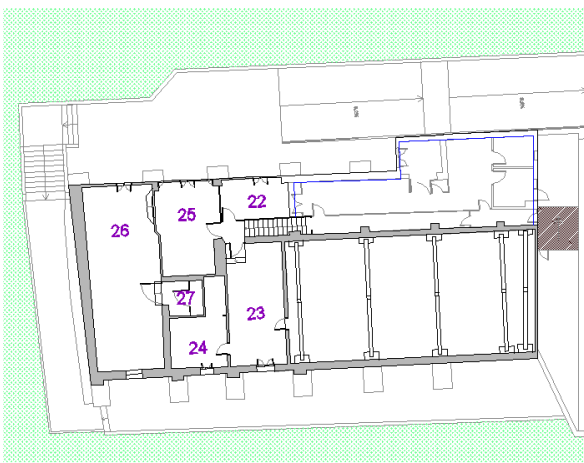

Graphic 5. Second Floor



Picture 1



Picture 2



Picture 3



Picture 4



Picture 5



Picture 6



Picture 7

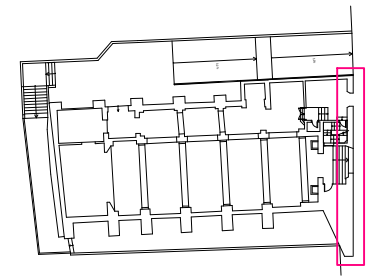





Picture 1



Picture 2



Picture 3

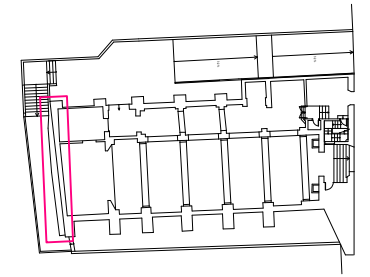

Picture 4



Picture 5

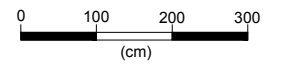
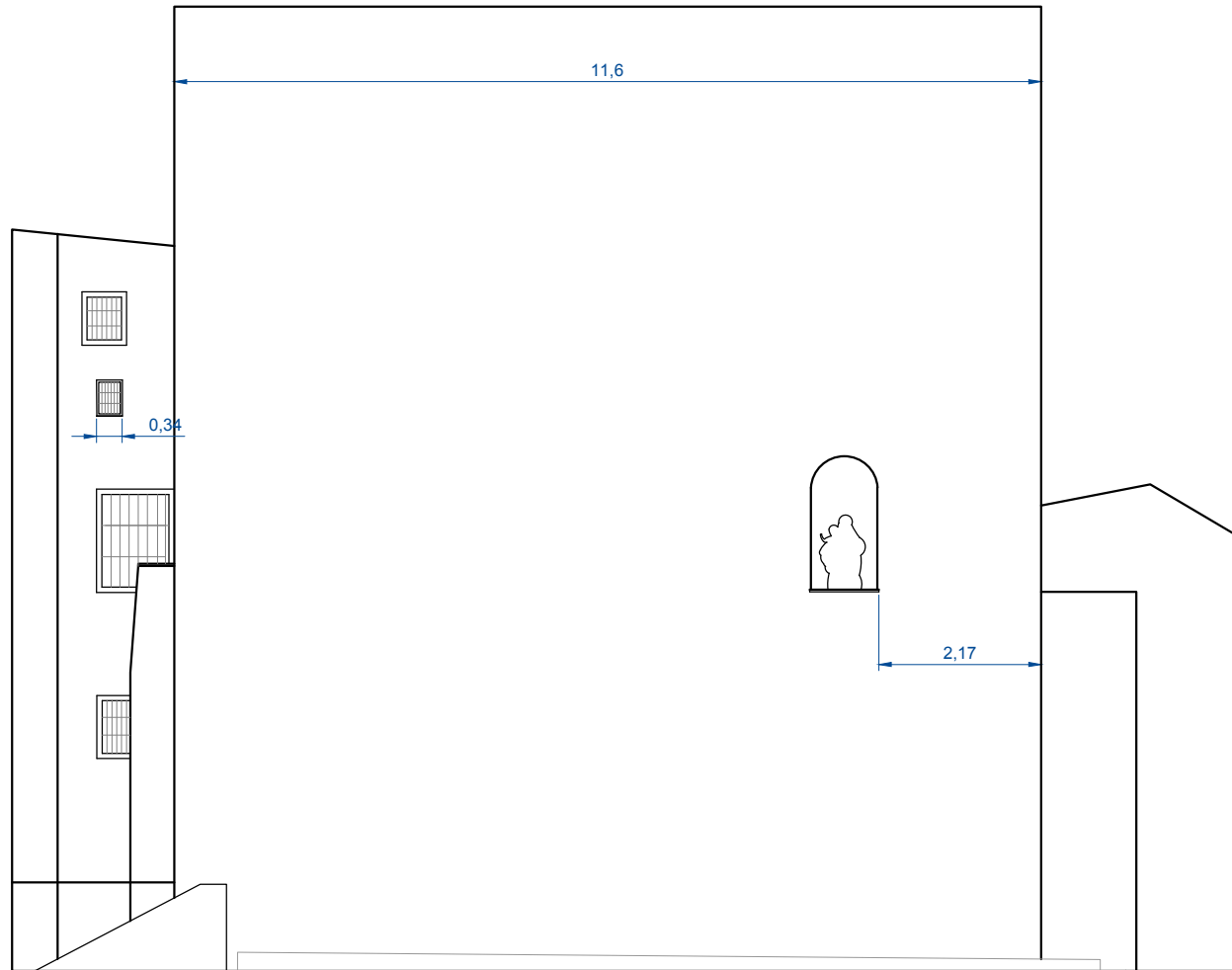



Picture 1



Picture 2



Picture 3



Picture 4

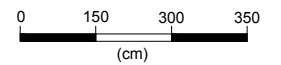
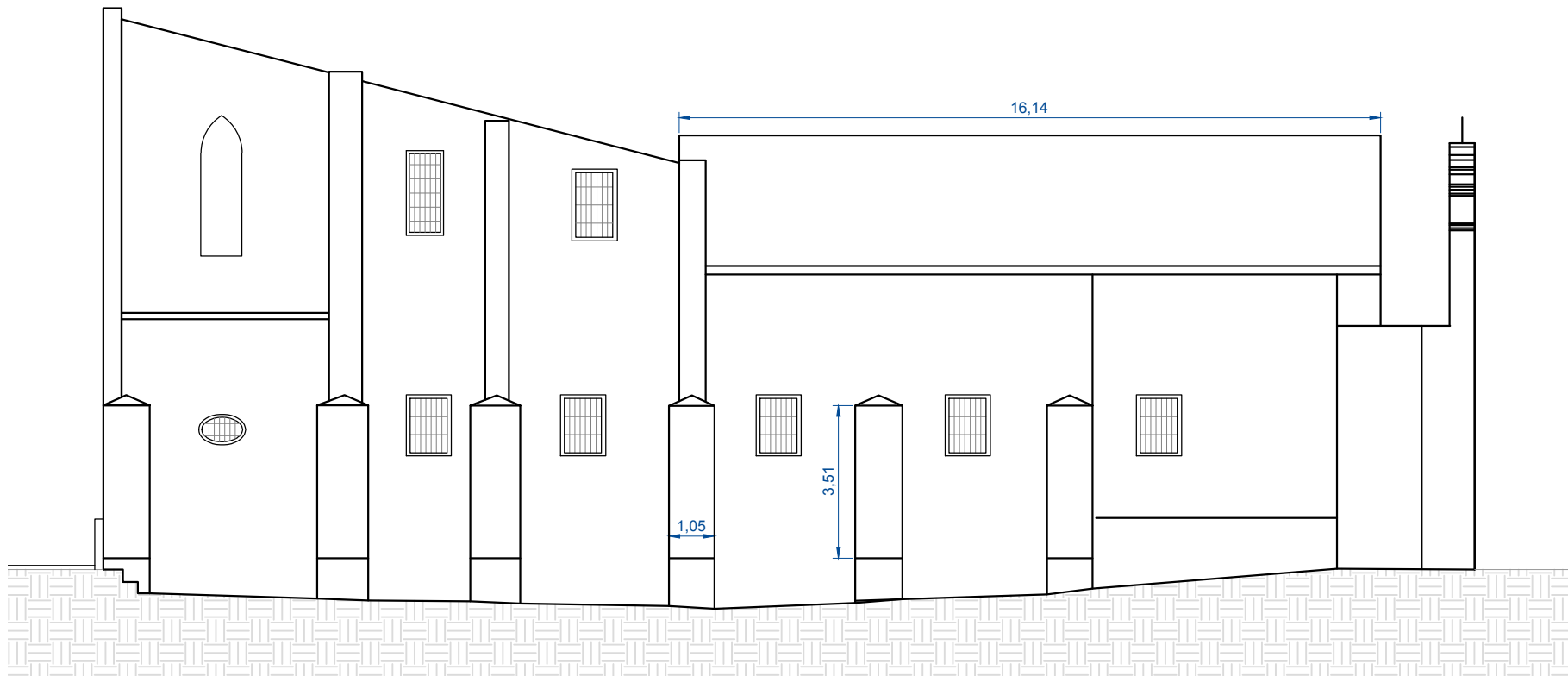
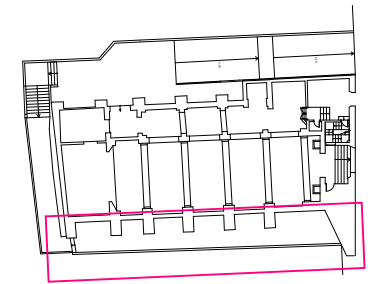



Picture 1



Picture 2





Picture 3



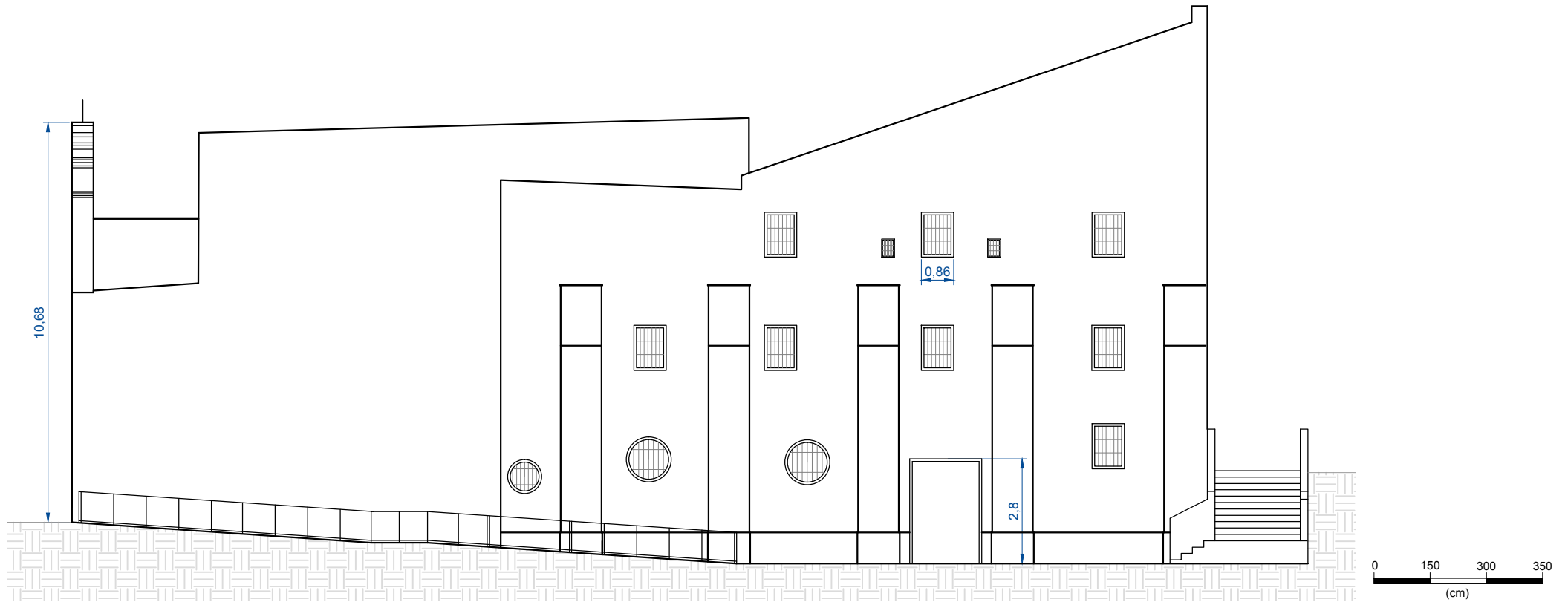
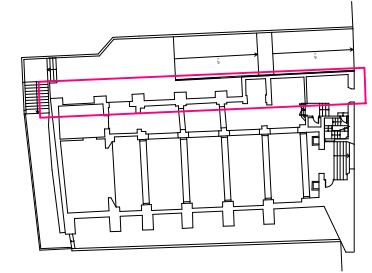

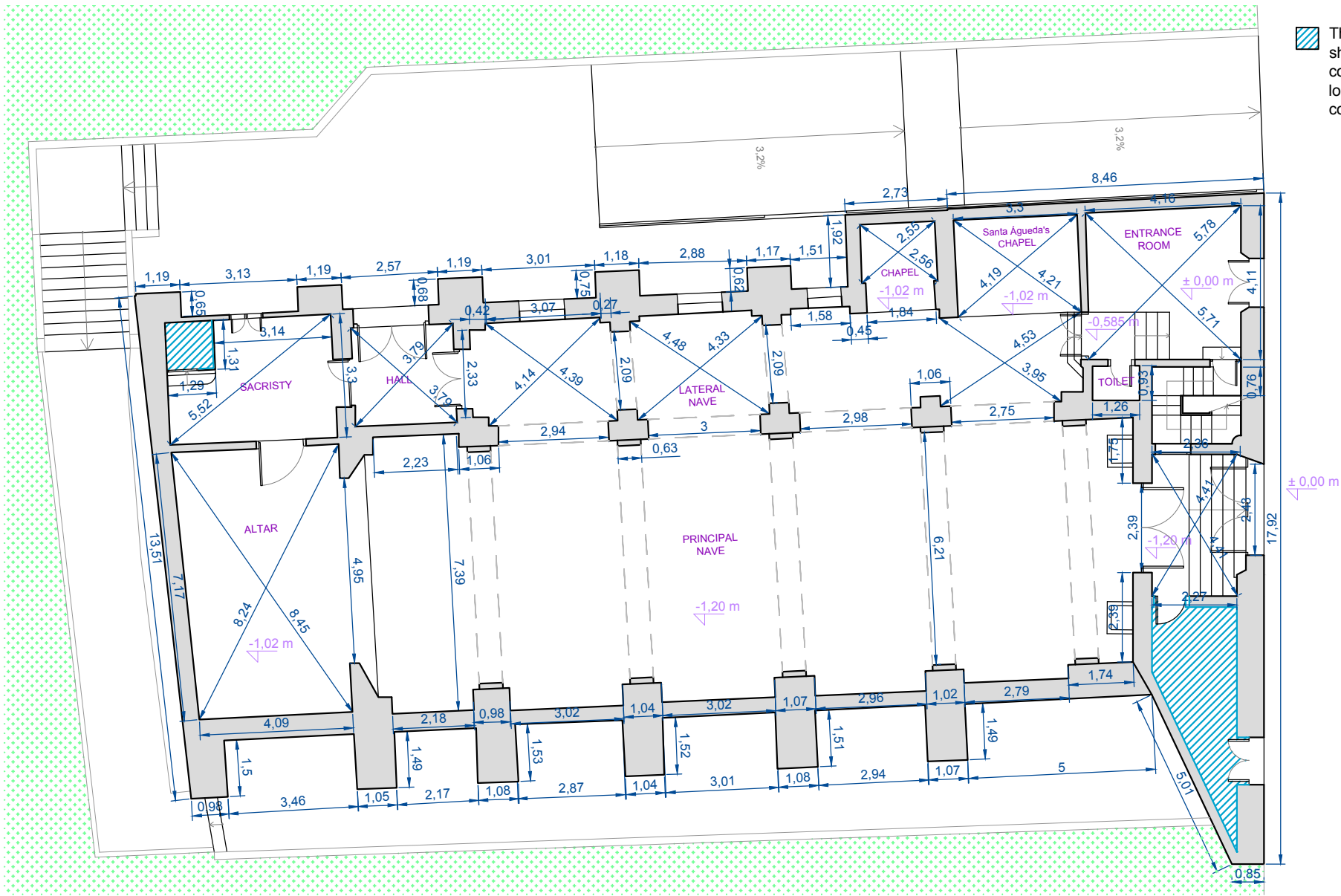
Picture 4





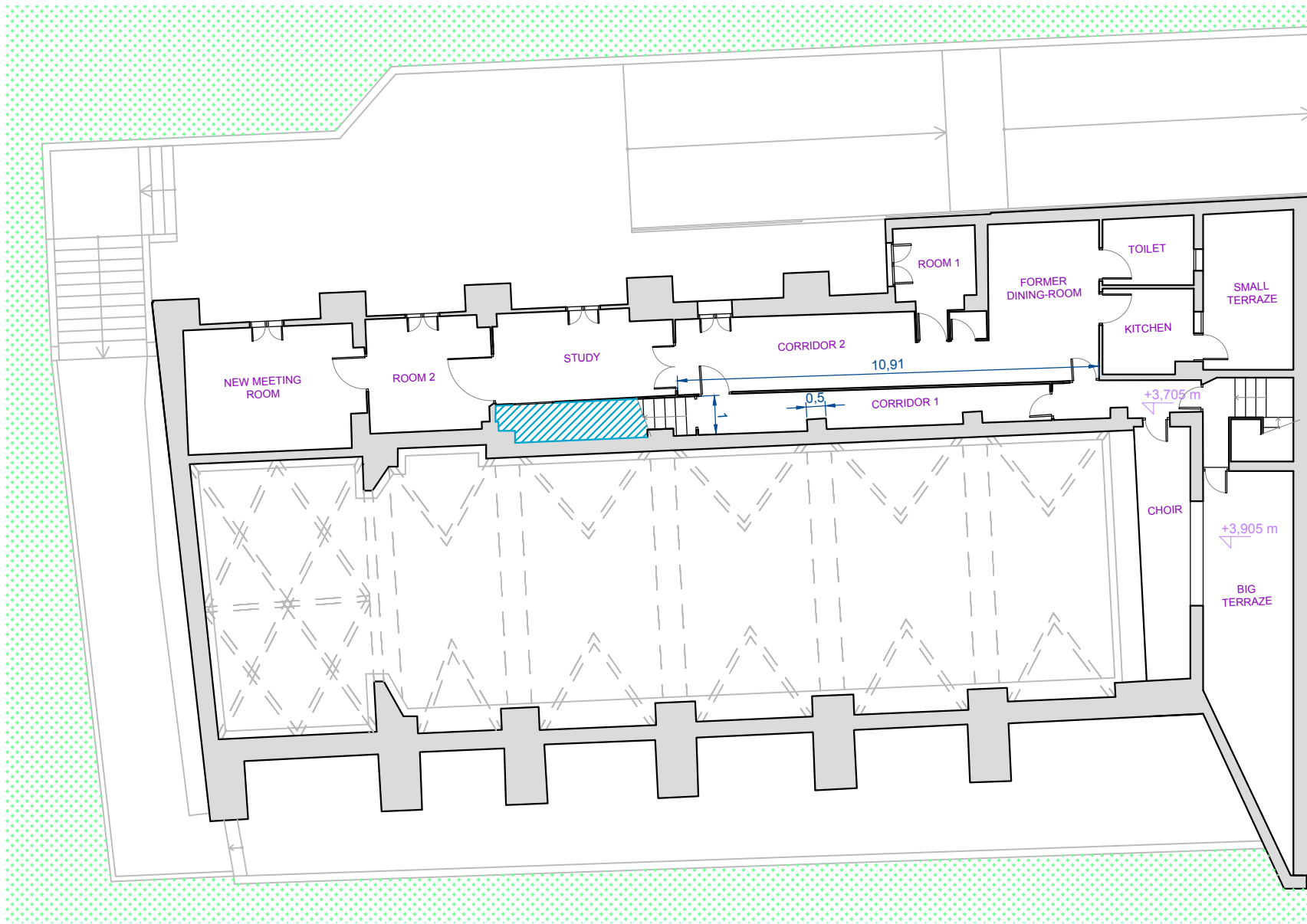

 The lines in blue shading show a hypothesis of how could be built, following the logical order of the construction applied.

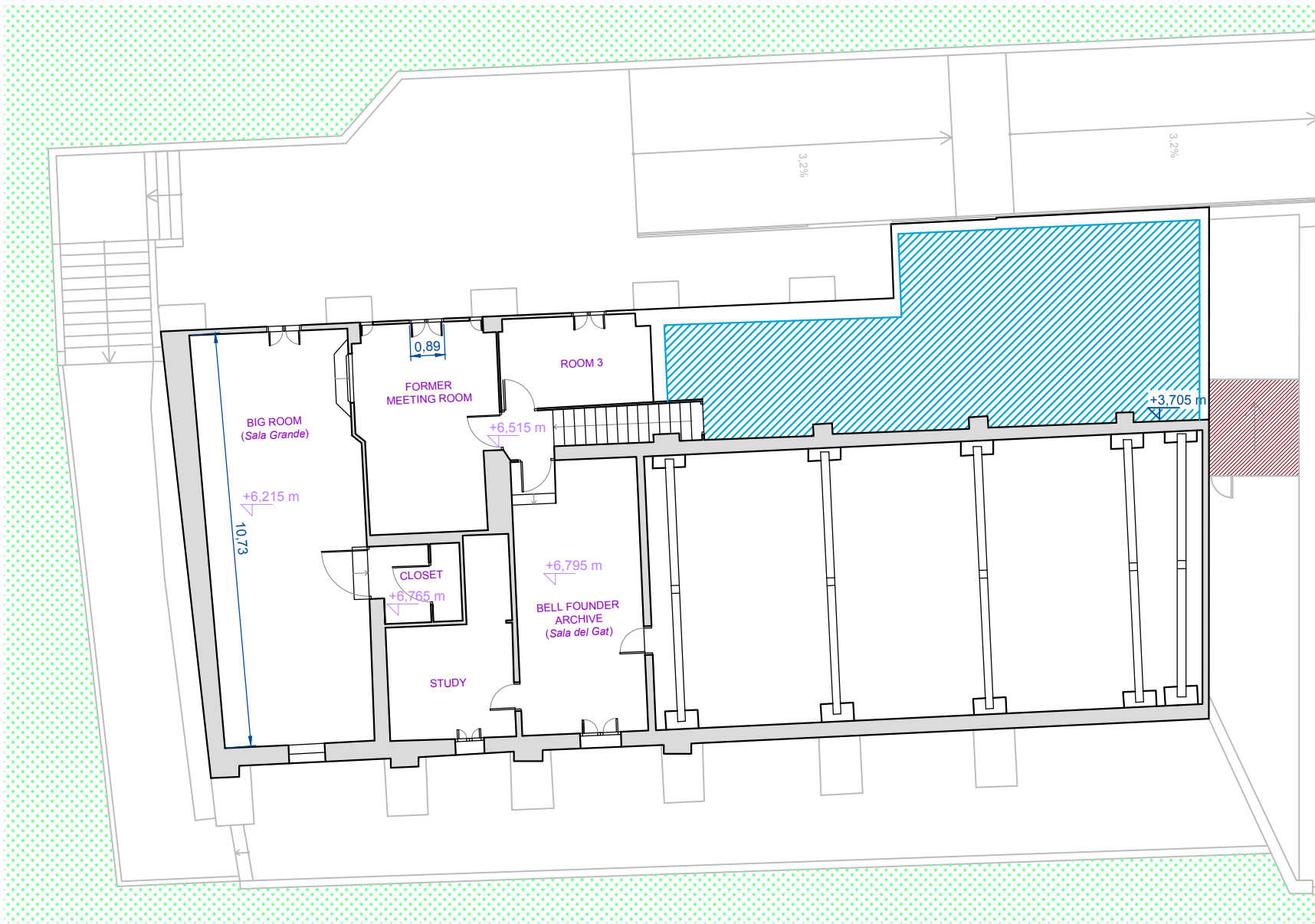

 The lines in blue shading show a hypothesis of how could be built, following the logical order of the construction applied.



 The lines in blue shading show a hypothesis of how could be built, following the logical order of the construction applied.

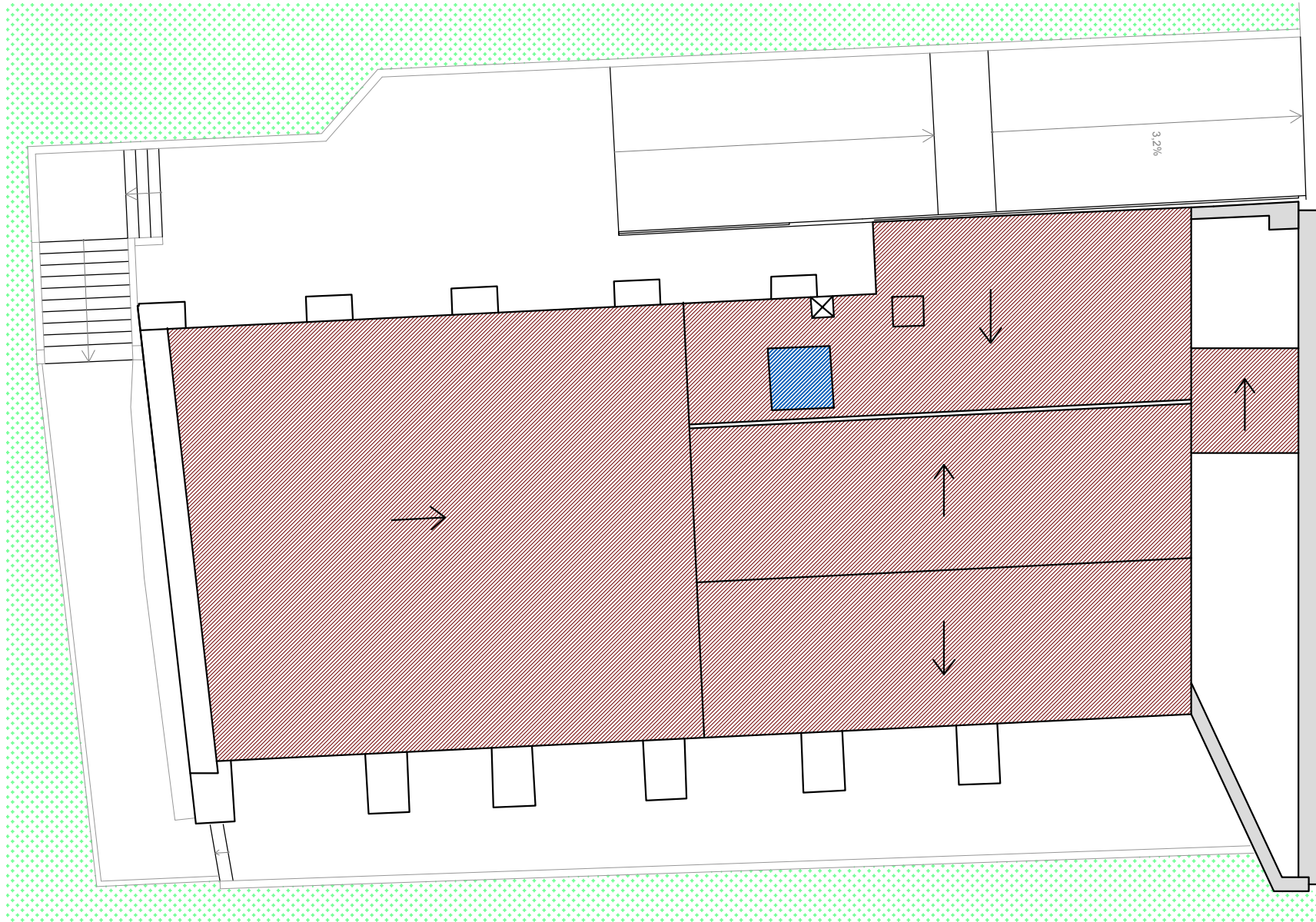

Roof view 1



Roof view 2

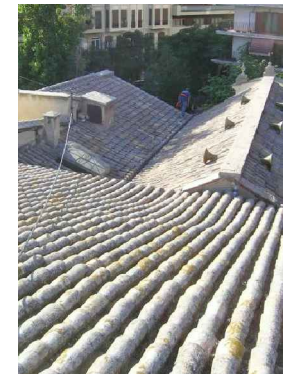

Roof view 3

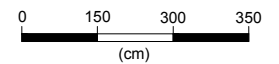

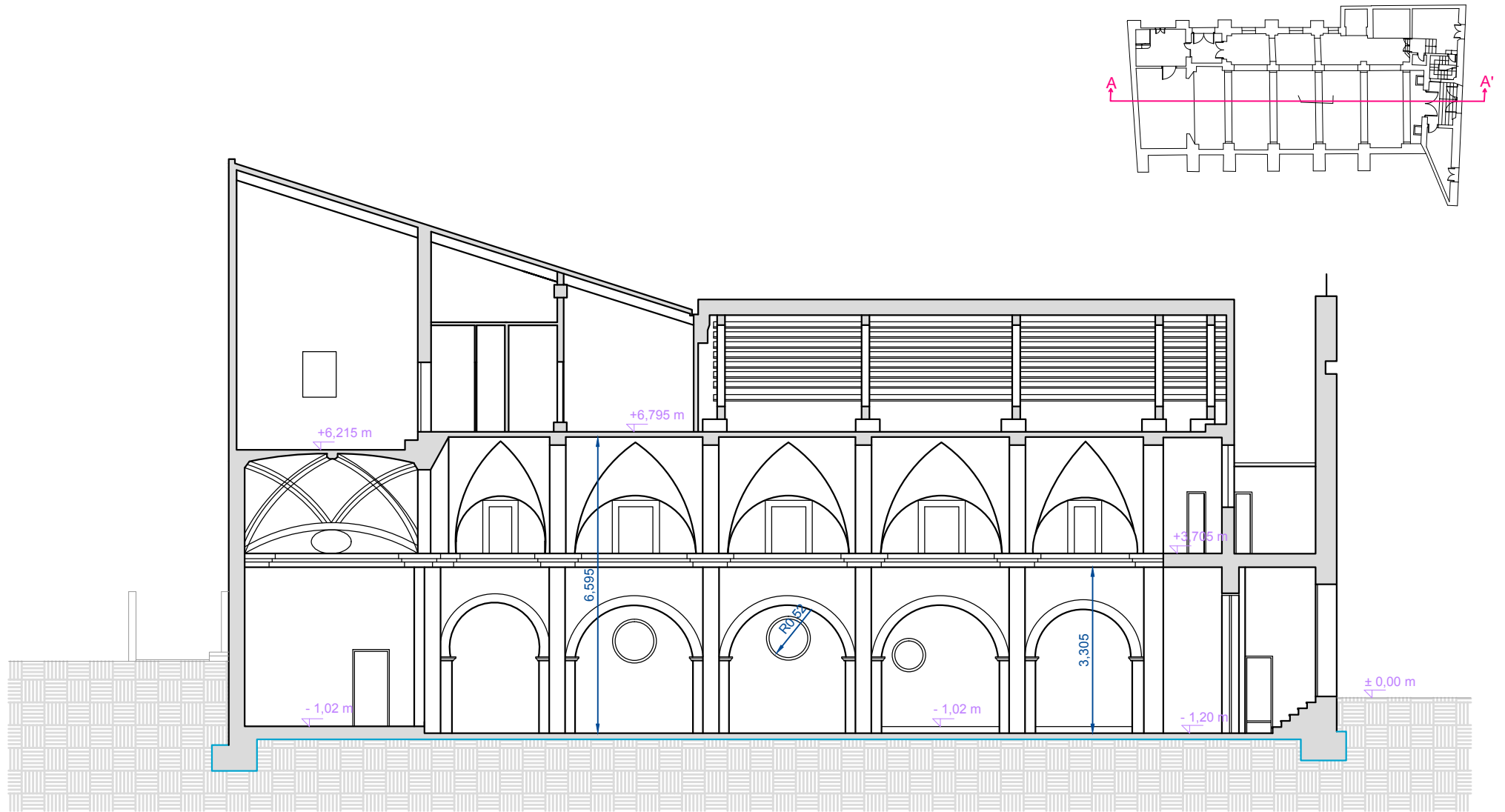

— The lines in blue color show a hypothesis of how could be built, following the logical order of the construction applied, as well as the plans made years ago by architect Salvador Vila.

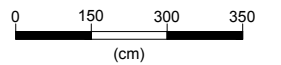



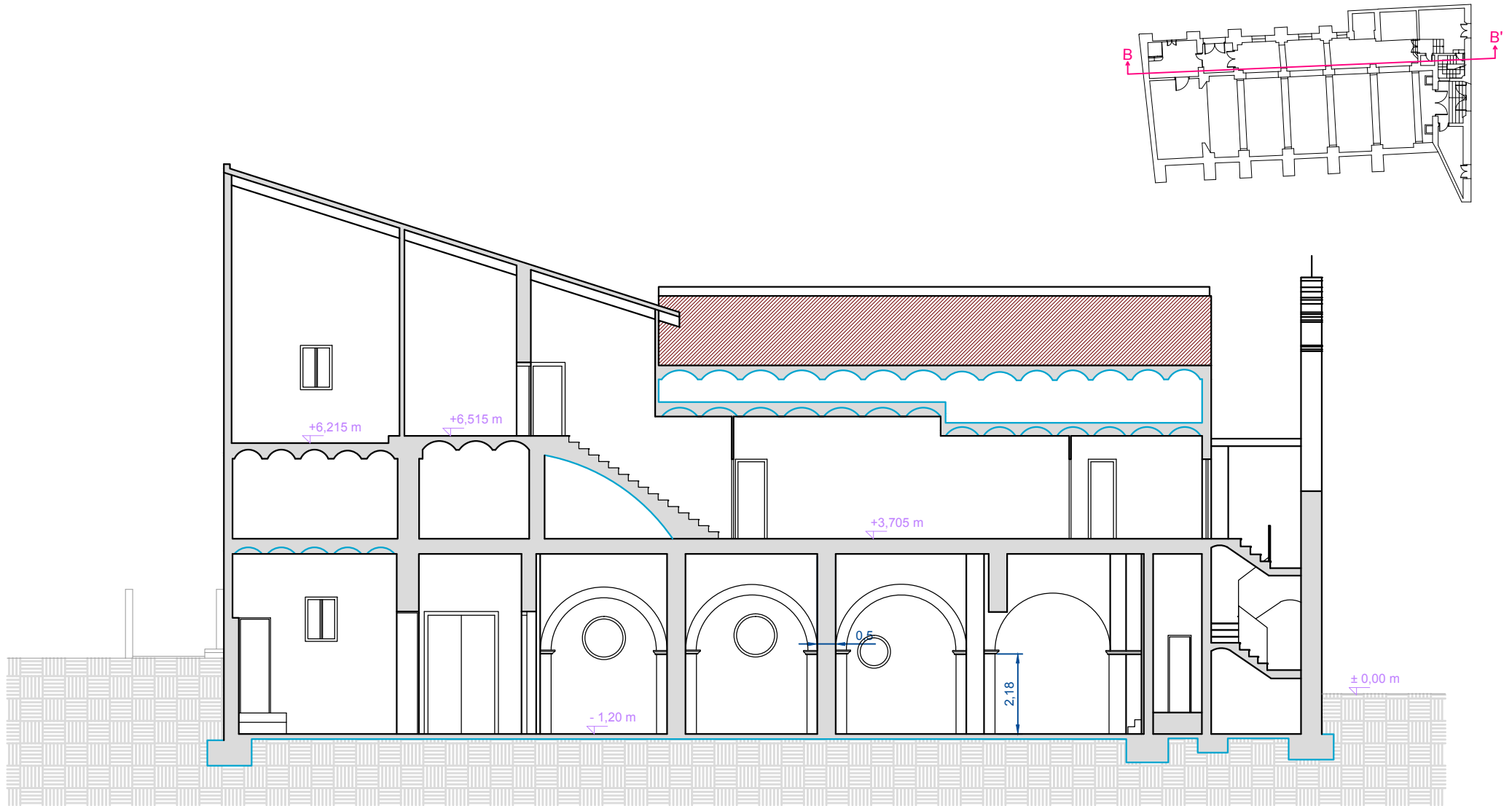

— The lines in blue color show a hypothesis of how could be built, following the logical order of the construction applied, as well as the plans made years ago by architect Salvador Vila.

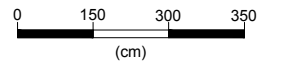

— The lines in blue color show a hypothesis of how could be built, following the logical order of the construction applied, as well as the plans made years ago by architect Salvador Vila.

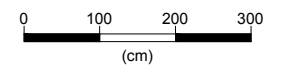
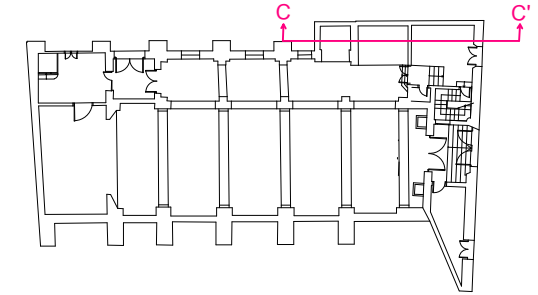
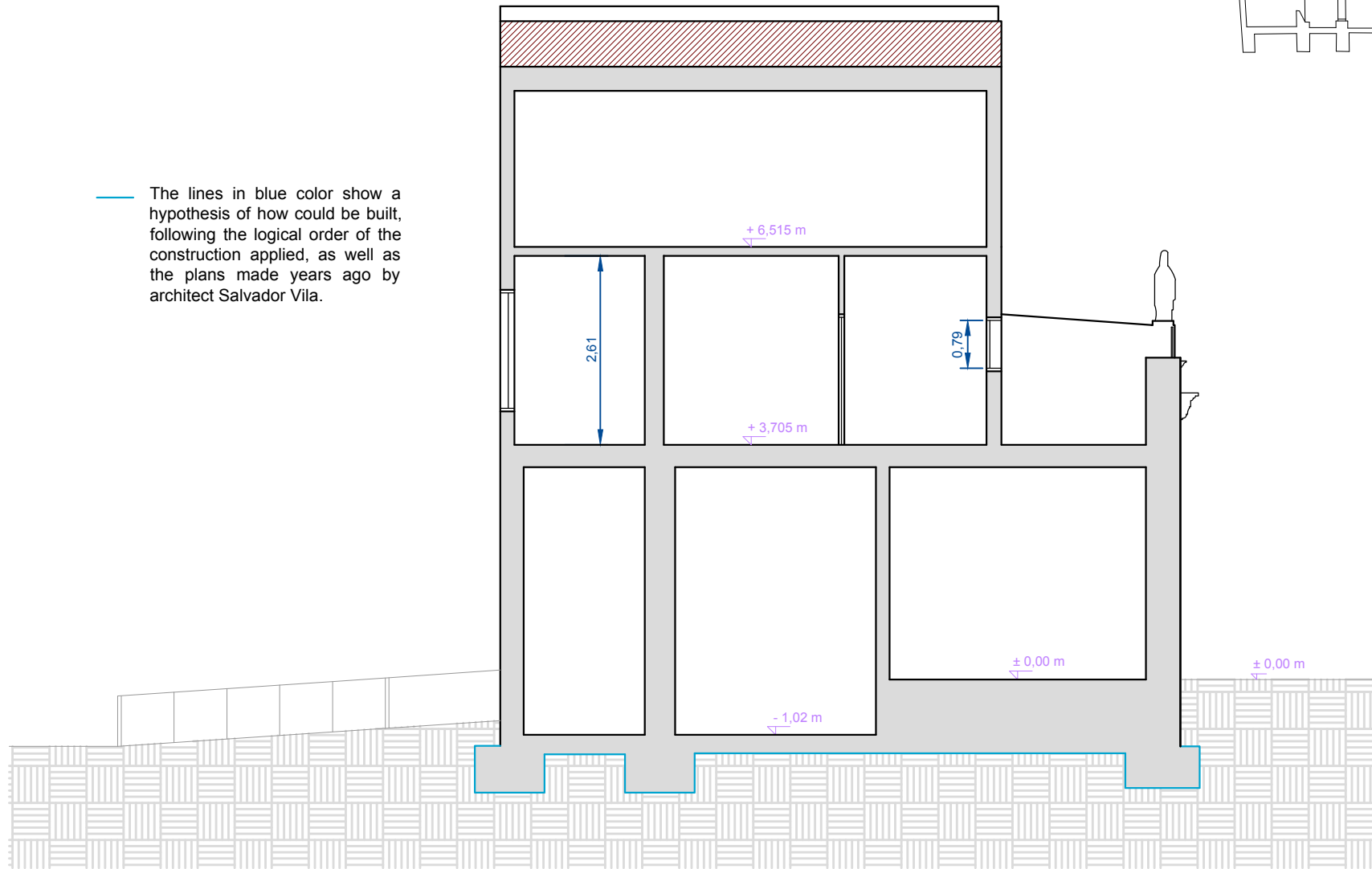

— The lines in blue color show a hypothesis of how could be built, following the logical order of the construction applied, as well as the plans made years ago by architect Salvador Vila.

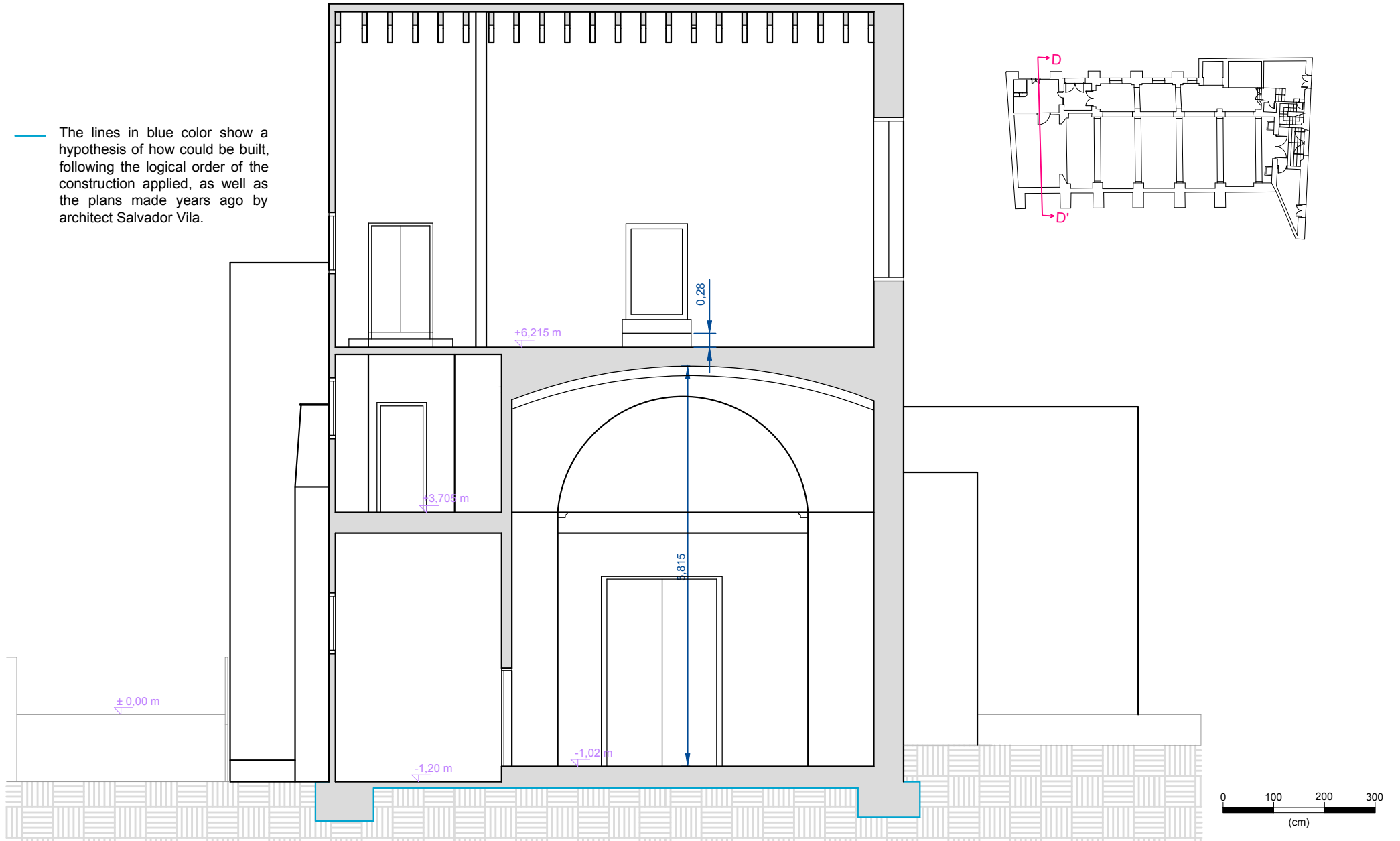

The lines in blue color show a hypothesis of how could be built, following the logical order of the construction applied, as well as the plans made years ago by architect Salvador Vila.

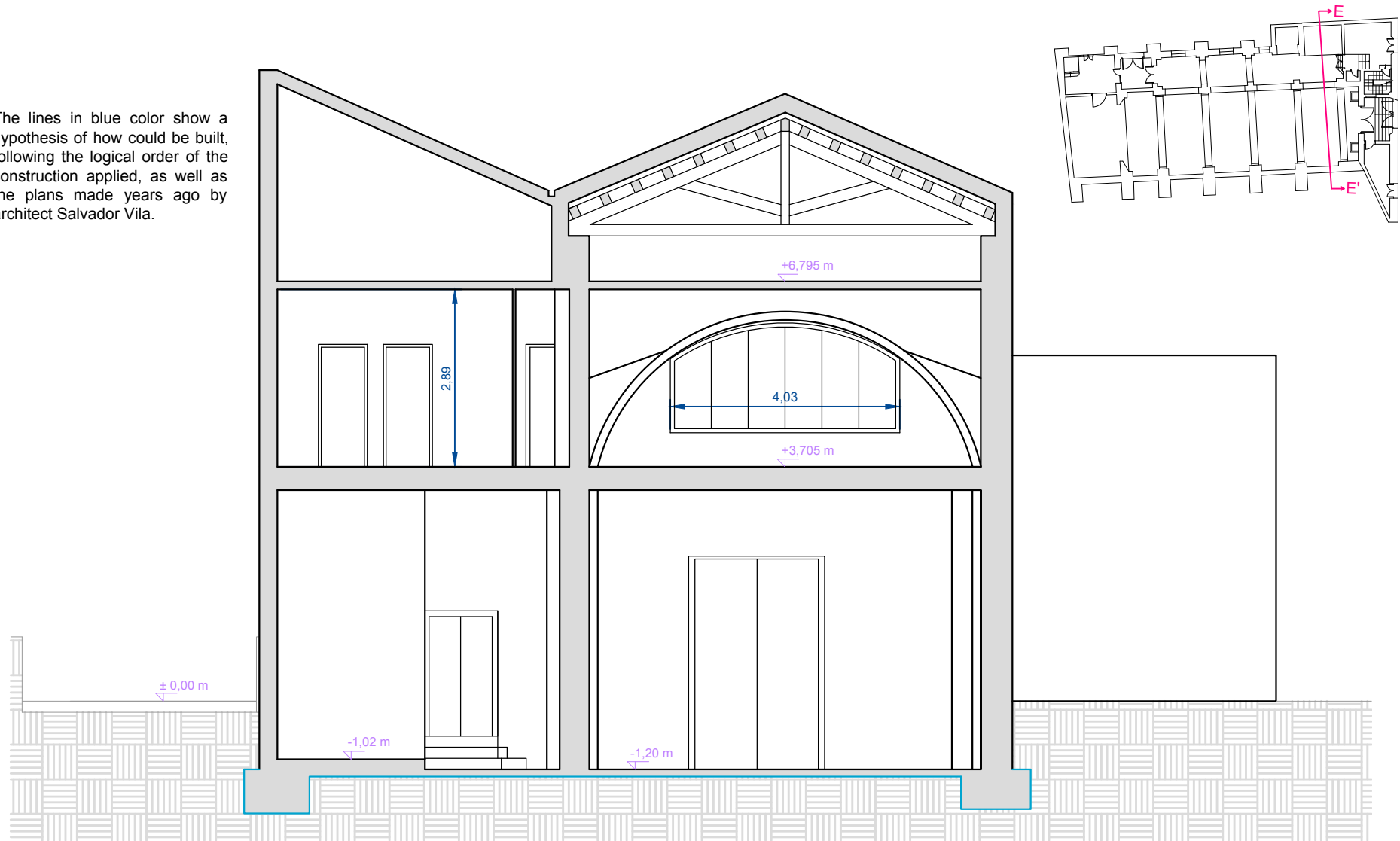

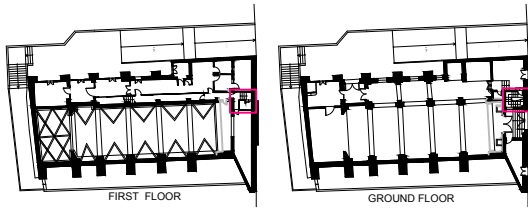

Picture 1



Picture 2



Picture 3

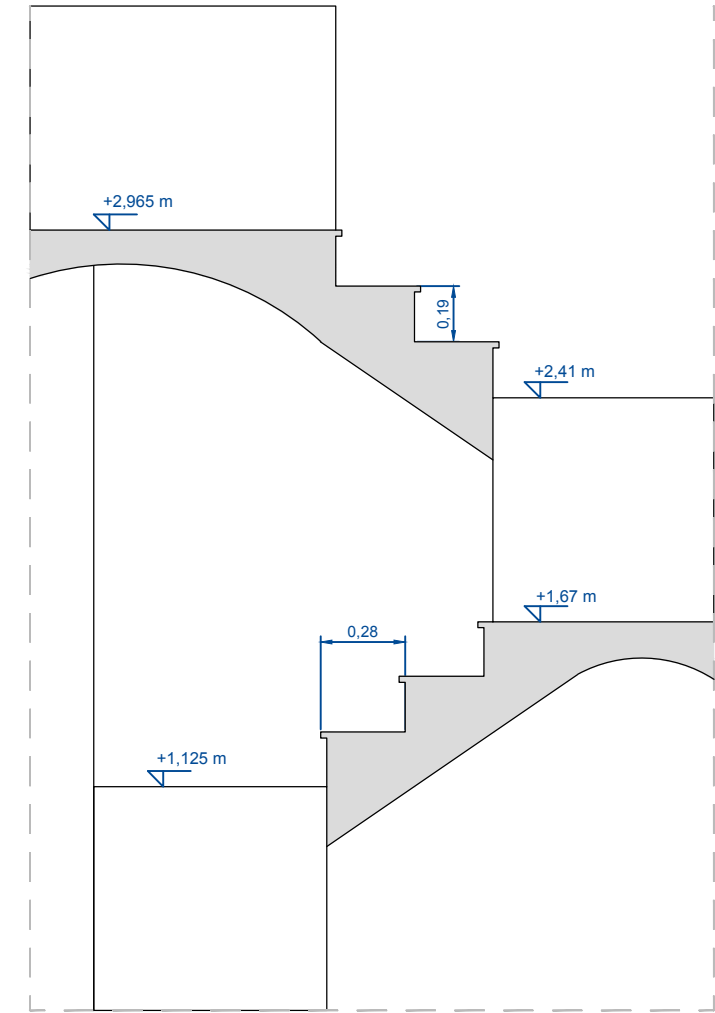
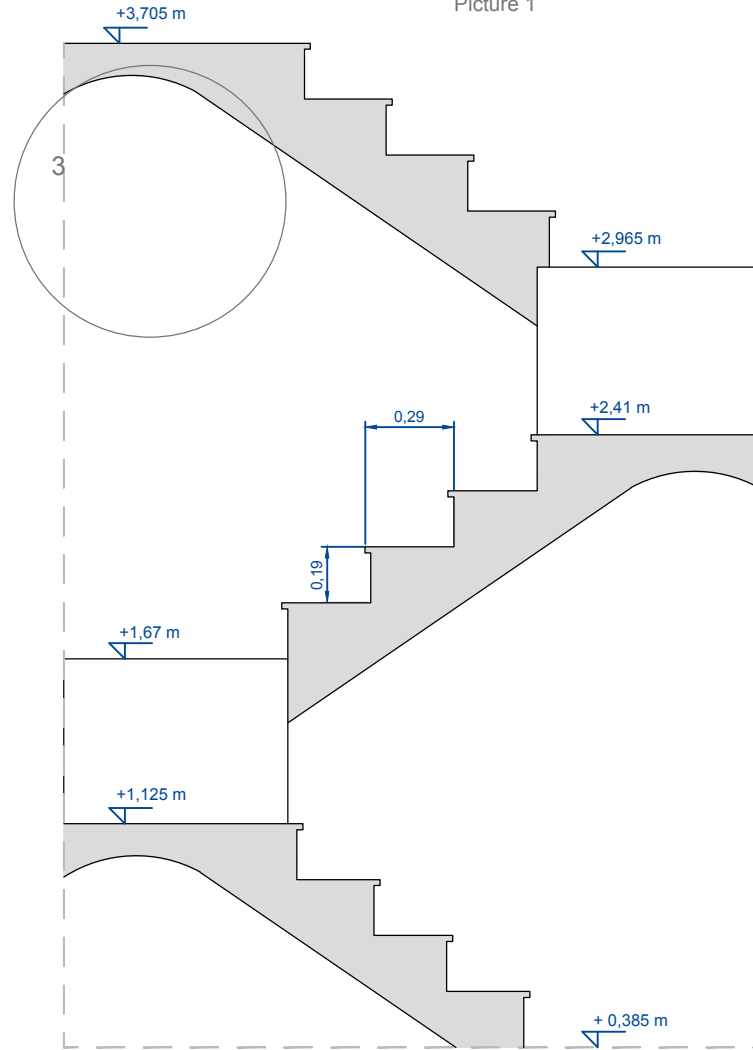
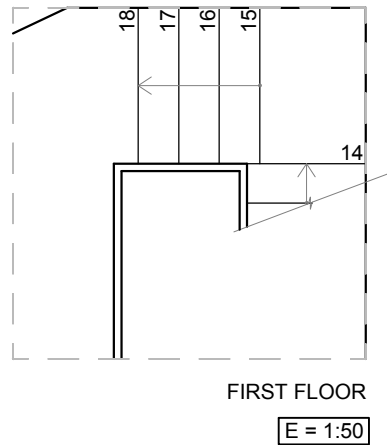
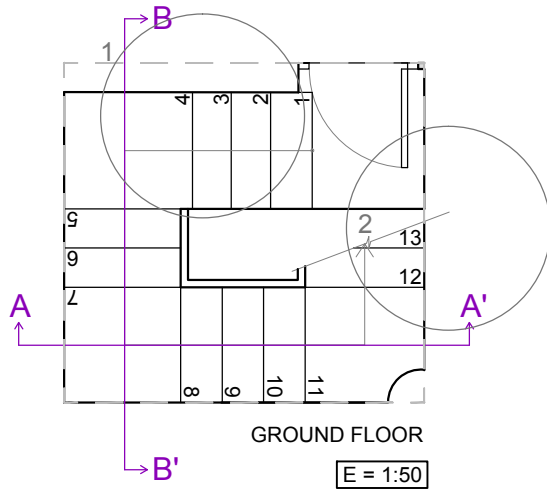

## 4. COMPOSITION AND ARCHITECTONIC ANALYSIS



## 4. COMPOSITION AND ARCHITECTONIC ANALYSIS

It is necessary to understand how the buildings were conceived in the past in order to understand how they are conceived nowadays. Therefore, it would be interesting to complete a comparison in composition and architectural analysis between the ancient Greece and the present time.

The most ancient Architecture Tractate that has been conserved is *De Architectura*, from Vitrubio, a roman architect from 1<sup>th</sup> Century BC. *De Architectura* is a joint of 10 books: books 1 to 7 are about the “reasons” of the buildings; the last 3 ones are dedicated to water constructions, gnomonic and machines. In them, Vitrubio is especially dedicated to explain the architecture’s classic orders: Doric, Ionic and Corinthian.

The *Doric order* was firstly used. The Greeks were the firsts on trying to search for the proportion in their buildings: they did an analogy between the size of a man’s foot with his height and the diameter with the height of the columns in the temples. The conclusion was the man’s height was 7 times his foot, so they began to build the columns with a height that was 7 times its diameter.

A common sense of beauty reached all fine arts, in that way the concept of Order was a try to assess the appropriate rules for beauty in architecture.

Afterwards, with the *Ionic order* it was adopted a female measure canon, proportioning a slimmer relation. The height/diameter proportion went from 7/1 to 9/1. The capital’s volutes were a reference to women’s hair, the shaft’s grooves to their dresses and the base to the feet.

The *Corinthian order* was more individual and romantic. The columns were even slimmer and the capitals had acanthus leaves sculptures.

The buildings composition consisted in symmetry, which was based in proportion. The Vitrubian symmetry was a groups of measures linked to the mathematics: the proportion is the equality of two reasons (or *modules*, as Vitrubio called them).

“The symmetry is the system: the proportion is the mechanic of the system. And the reason is the base of the system” [Joaquin Amau Amo, *La Teoría de la Arquitectura en los Tratados. Vitruvio*]

According to Vitrubio, the architecture consists in the following concepts:

**TAXIS** or *order*. It is understood as a code or regulations of the different parts of the building.

**DIATHESIS** or *disposition*. It’s referred to the graphs, the floors, the elevations and volumes.

**EURYTMIA**. It’s the result of the symmetry, the harmony of a well proportioned building.



**SYMMETRIA.** It's the union of applying the order and the disposition.

**DÉCOR** or *appearance*. Makes reference to the beauty of a building. It needs to have a suitable style regarding its function and the orders don't have to be mixed.

**OICONOMIA.** The economy of materials and space.

In **short**, the qualities every building has to collect are "*firmitas, utilitas, venustas*" (strength, utility and beauty). Strength as for a secure foundation and a good choice of materials. Utility as for the economy and good disposition. And beauty as for the symmetry.

Nowadays, the architectonic and composition analysis can be done by studying physic elements and non-physic elements. The physic elements are the parts that the building is composed of (walls, doors...) while the non-physic elements are the functions the building is destined to.

The first item to analyze is the *exterior volume*: if it has known geometric shapes or its composition by subtraction and addition. Once the volume is defined, the floor structure is analyzed. It is confirmed the module's repetition in the measurements, proportion, symmetry, if there are lineal associations or any defined connection.

Afterwards, the *functions* of the building are analyzed. Depending on the activity that is going to be developed there, the building may be divided in:

- **Day/night areas.** The day areas are destined to daily actions, while the night areas are rest spaces, mainly bedrooms. Therefore, this function won't be analyzed in the Hermitage, as it has only day areas.
- **Public/private areas.** The public areas are designed so the public can enjoy them, while the private areas are reserved for a particular group of people (mainly the owners of the building or the workers in it). In the Hermitage's case, the public area would be the interior of the church and the Brotherhood rooms destined as a museum; while the private areas would be the sacristy and the rest of the Brotherhood rooms.
- **Servant/served areas.** The servant areas are the ones giving a service to others. These other rooms that take advantage of it are the served area. In the Hermitage case, the servant area would be the sacristy because it's a room servant to the church, and the kitchen in the Brotherhood rooms.
- **Walking/staying areas.** The walking areas are the corridors and the halls that lead to another rooms, this is to say, the passable places. The staying areas would be destined to the permanence of people in them. For instance, in the Hermitage the walking area would be the lateral nave and the staying area the main nave, where are the banks to attend the mass. In the Brotherhood rooms, the walking areas would be the corridors and stairs and the staying areas would be rooms.

**PUBLIC/PRIVATE AREAS**

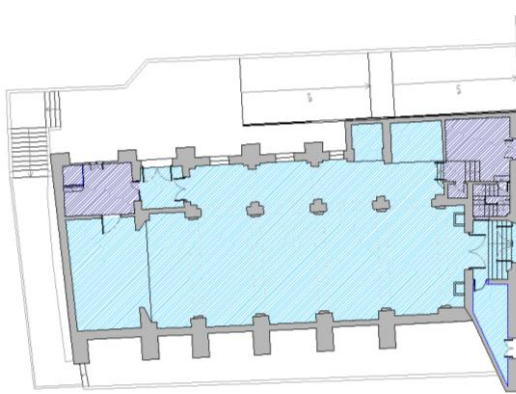

Graphic 6. Ground floor

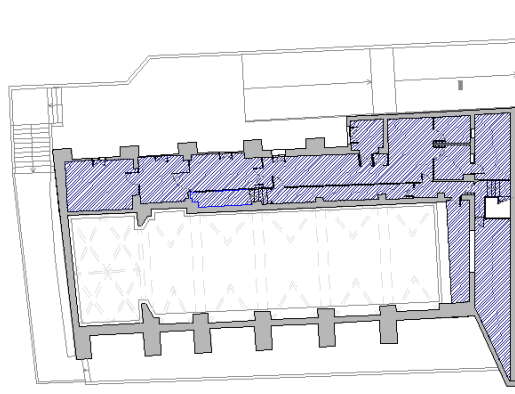

Graphic 7. First floor

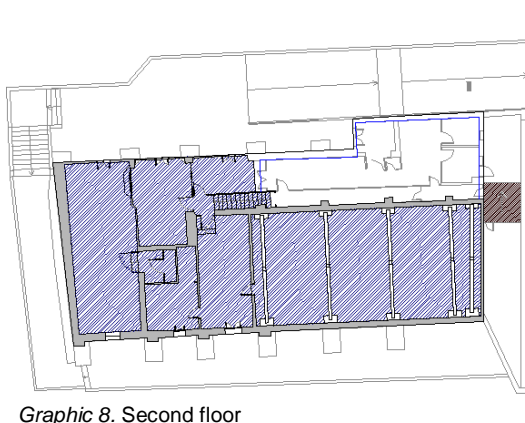

Graphic 8. Second floor

- Public areas
- Private areas

**SERVANT/SERVED AREAS**

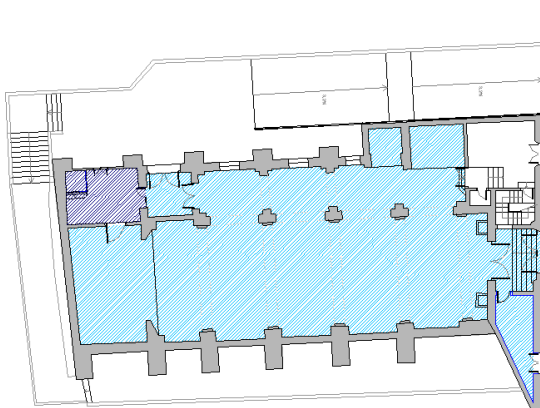

Graphic 9. Ground floor

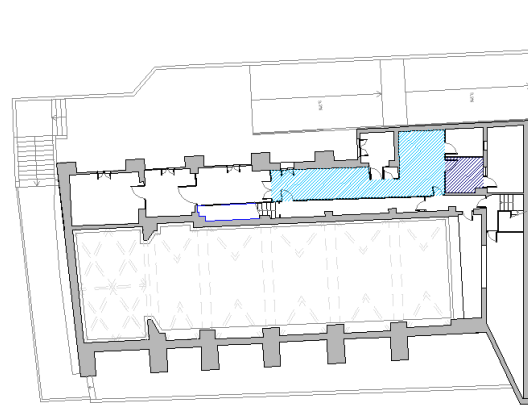

Graphic 10. First floor

- Served areas
- Servant areas

### WALKING/STAYING AREAS

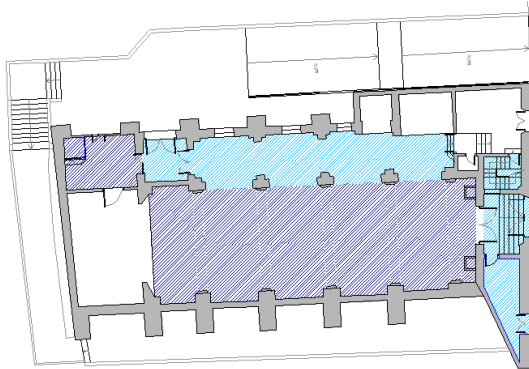

Graphic 11. Ground floor

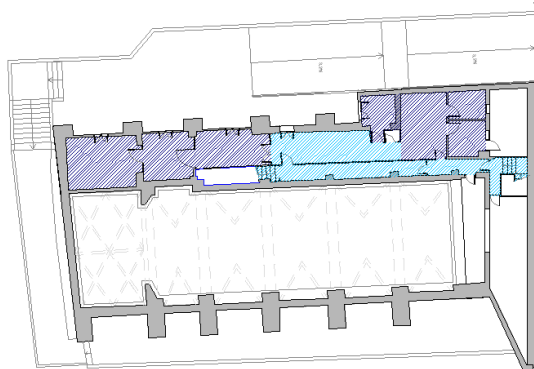

Graphic 12. First floor

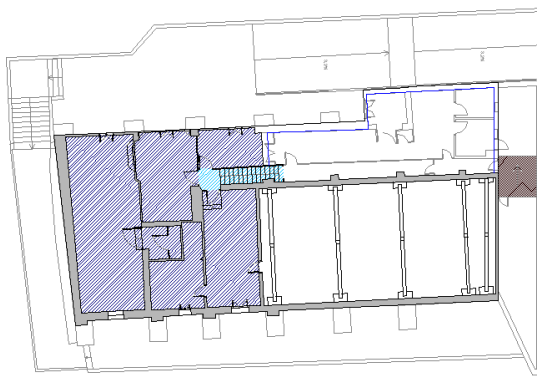

Graphic 13. Second floor

- Walking areas
- Staying areas

## ARCHITECTONICAL SETTINGS

---

Santa Lucia's Hermitage was started to be built in 1.400 and it was finished in 1.511. As a consequence of it, the Hermitage was developed when the Gothic style was at its peak in Spain. Therefore, it was initially traced with typical elements from the named *Reconquest Churches*. This typology of churches was characteristic in the Valencian Gothic style. Nevertheless, in its interior can be also observed several Baroque altarpieces, as well as some elements from this architectural style. In the same way, the Hermitage was enlarged in the 18<sup>th</sup> Century, in the neoclassic style, although it holds no influences from this period.. As a consequence of all these facts, it can be affirmed that the Hermitage has an eclectic style from the beginnings, due to it doesn't follows a specific architectural style.

The Valencian Gothic *Reconquest Churches* programs had functional matters, because of the need of creating new temples after the Jaime I reconquest. This type of churches used to have a rectangular floor with a single nave and the presbytery rectangular as well. This suggests a clear influence from the *paleocristiana* basilica's floor. These churches used to have a gable wood roof over Gothic ashlar arches, which could start from the floor or the walls. The transverse arches were placed with little separation space between themselves in order to balance the beam's divisions.

On the other hand, the walls could have little thickness, because they didn't perform a structural function and just supporting their self weight. Only the transverse arches needed buttress where the effect of horizontal forces should be opposed. It was also common in these churches to present variations from their initial outline, such as the appearance of chapels attached to the walls in the lateral spaces between arch and arch, or building the apse in a polygonal shape.

According to the described features, the *Reconquest Churches* structure was simple and economic, and that's the reasons why they were frequently employed along the Spanish Levant and the French south-east during the 12<sup>th</sup> to the 15<sup>th</sup> Centuries. Furthermore, this construction typology was also used for building great one floor contain-rooms.

There can be indentified quite enough elements from this type of churches in Santa Lucia's Hermitage. Firstly, it has a rectangular floor with a principal nave and another smaller on the right, and the presbytery follows a rectangular shape as well. The principal nave has a gable roof initially Gothic, which eventually was covered by barrel vaults with lunettes, apart from the presbytery, where can be still observed a Gothic vault (even though the nerves doesn't have a structural function). The transversal arches are at an average of 3 meters of distance between themselves, and lay on the buttress and the pillars. Therefore, the walls only support their own weight. A variation that can be found is the presence of two attached chapels on the right side of the wall, next to the lateral nave.

As for the Baroque influences, they were above all related to the painting and the sculpture than the architecture. The *baroque paintings* were based in the clear realism. The compositions enhance by their simplicity and chase the reflex of the nature. The topic was principally religious, and the noble portraits and still-lives were very popular. The *baroque sculpture* was centered in the religion, being the wood the

most used material. The material's expressivity, the polychromy and the use of artificial objects (such as natural hair, ivory teeth or crystal eyes) magnified this reality sense.

Another typical element of the baroque edge was the *altarpiece*. Its structure was divided in two parts: one inferior and another superior. In the inferior one, the salomonic columns were placed at the corners, leaving a central, golden and overdecorated space. In the superior part, it was common to find a sculpture or a painting surrounded by golden decoration.

All these pieces can be distinguished in the interior of the Hermitage. There are paintings in the altar and in the chapels. The sculptures can be found in some altarpieces and in the chapels. Furthermore, there're a total of five baroque altarpieces along the left side of the central nave, and another one bigger in the altar. Besides, the entire church is decorated with golden carving, as well as the altar table is truly influenced by this aesthetic.



Picture 80. Baroque altarpiece, altar table and paintings placed inside the Hermitage.



Picture 81. Baroque sculpture place in a Hermitage chapel.

## AREAS

Santa Lucia's Hermitage is divided in three levels: the ground floor, the first floor and the second floor. The church is placed in the ground floor, whose height rises until the first floor in the main nave, as well as the access to the Brotherhood House. In the first floor the Brotherhood House is extended over the lateral nave. Finally, in the third floor, the Brotherhood House is located on top of the presbytery and covering the main nave there's a gable roof.



Graphic 14. Santa Lucia's Hermitage Volume

The Santa Lucia's Hermitage main façade was constructed by Sebastián Monleón Estelles in 1860. It has three doors, and above the main and central one there can be found a ceramic panel with the following inscription: *Ermita de / Santa Llúcia / 1400 – 2012*. The two dates make reference to the year it was started the Hermitage construction and the year the last refurbishment was ended.

Over the main door it can be also observed a Santa Lucia terracotta figurine in a niche, as well as two hollow alcove made by Luis Peseto in 1865. There, are placed two bells named *Santa Lucía (1786)* and *Santa Agueda (1872)*. On the façade's two opposite sides there are two sculptures representing *La Virtud (The Virtue)* y *El Martirio (The Martyrdom)*, and on the top there can be found four vases.

Two entrances facilitate the access of the Hermitage.. On the one hand, there's the principal entrance by the main façade. Immediately after crossing the door, there are five steps to walk down. In front of the steps there's the door which takes inside the church. On the other hand, in the recent exterior's refurbishment (2013) there was made a ramp on the west side and an access in the west façade. Therefore, the free access for disable people is currently guaranteed.

The Brotherhood Rooms have also two accesses. The first one is placed in the main façade's right door. The second one in placed inside the church, at the bottom of the lateral nave. For getting into the Brotherhood rooms throughout this second

entrance, it is needed to go up five steps, so it can be said that the accessible entrance to these rooms is the one placed in the main façade.

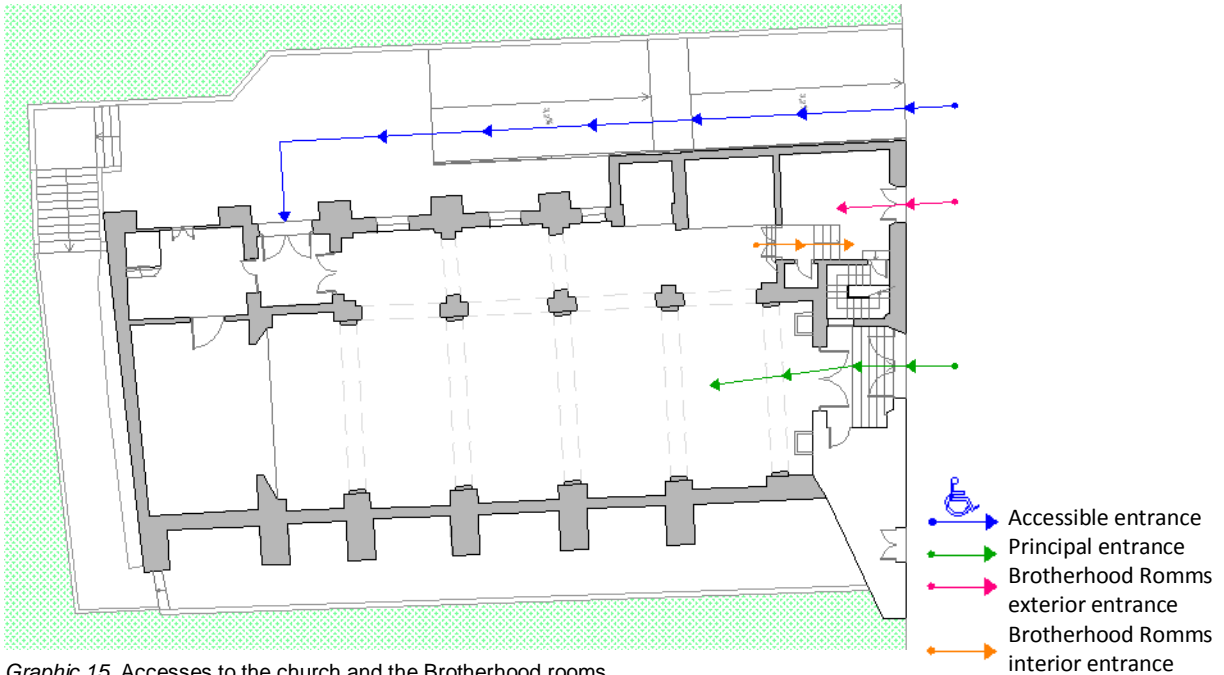

The **principal nave** has a five stretches gothic vault, which lately was recovered by a barrel vault with lunettes, apart from the presbytery, where there's a Gothic vault. Nevertheless these ridges have just an ornamental function.

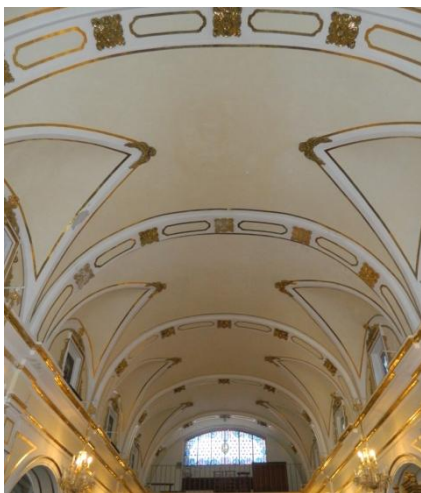

Picture 82. Barrel vault with lunettes



Picture 83. Gothic vault

On the principal nave's left wall there are placed five Baroque altarpieces. Starting from the closest to the entrance there can be observed: firstly, a *Blessed Virgin* image (1); secondly, *San Antonio of Padua* (2); the third one is dedicated to *Saint Joseph* (3); in the fourth one there's a *Nuestra Señora del Buen Acierto* bust (4); and finally, in the altarpiece closest to the presbytery there's the *Goos Shepherd Christ* (5).

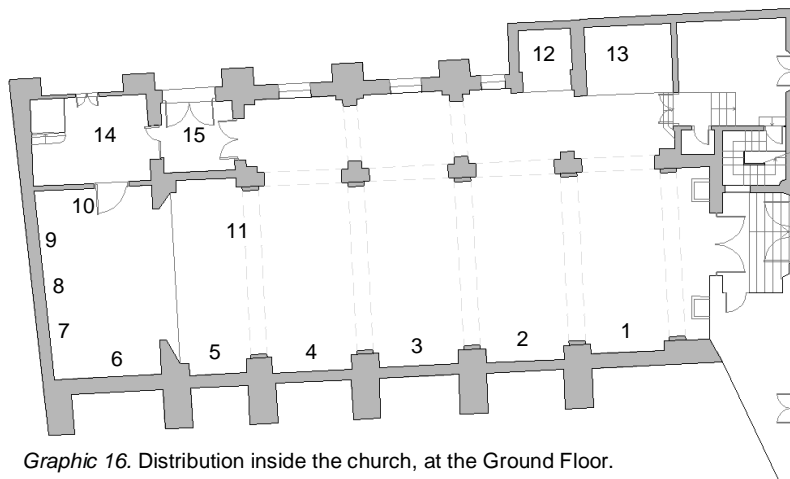

Graphic 16. Distribution inside the church, at the Ground Floor.



Pictures 84, 85, 86, 87 and 88. Baroque altarpieces 1 to 5 from left to right.

Beside the presbytery there's the altar, where the major altarpiece is placed (8). It is Baroque and has a Santa Lucia's image from the 18<sup>th</sup> Century at full-scale between two salomonic columns. On the top of the altarpiece it can be also observed a Sacred Family painting and a pontific and royal Brotherhood emblem. In the altar table there's a reliquary that holds part of the Saint arm. In both sides of the major altarpiece there are placed four paintings: one at each side of the altarpiece (7 and 9), and the other two on the lateral walls (6 and 10). The sacristy (14) is placed next to the altar, on the right side of the Hermitage. It is preceded by a hall (15) that gives access to the lateral nave and proportions light and air circulation.



COMPOSITION AND ARCHITECTONIC ANALYSIS



Pictures 89, 90, 91, 92 and 93. The Major Altarpiece (8) surrounded by pictures 6, 7, 9 and 10 from left to right.

Leaving the altar behind, on the right side of the central nave there's a simple altarpiece on the wall (11). In its alcove it can be observed a *Nursling Virgin* painting. Following the right side of the central nave it's found the separation with the lateral nave, by round arches.

On the lateral nave, which is shorter and narrower than the principal nave, the two only chapels of the Hermitage are placed. These two chapels are dedicated to *Santa Águeda* (Saint Agueda) (13) and the *Santísimo Cristo del Perdón* (Holy Forgiveness Christ) (12). In the first one can be found the *Retablo de las Almas* (The soul's altarpiece) from the year 1500. In the second one can be found a Virgin's bust from the year 1600.

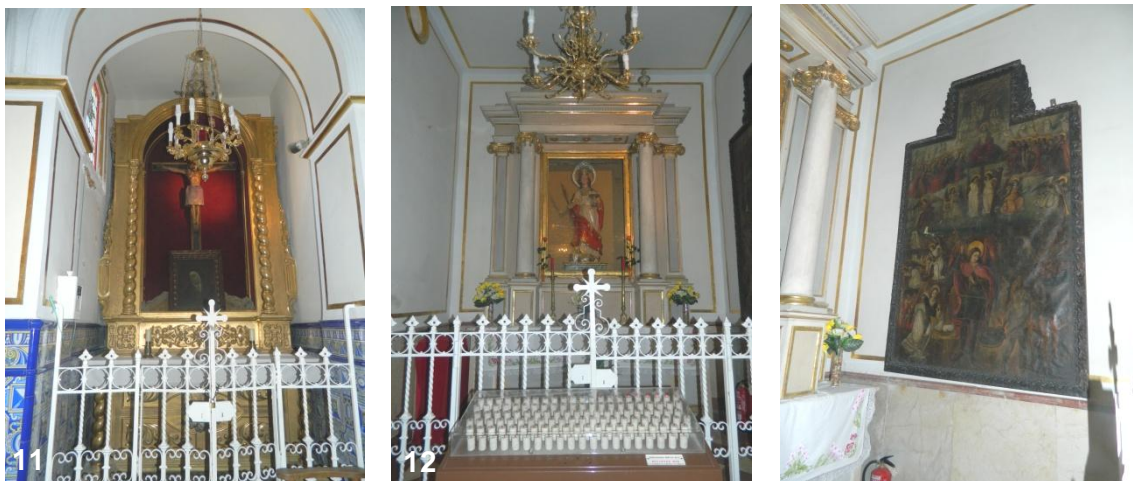

Picture 94, 95 and 96. *Santísimo Cristo del Perdón's* chapel (11) and *Santa Águeda's* chapel (12). In the picture on the right there's the *Retablo de las Almas*.

On the first floor at the bottom of the Hermitage it's placed the *High Choir*, where it's found a *harmonium* that belonged to Benlloch Cardinal.



Picture 97. The High Choir

**The Brotherhood House of Santa Lucia** is placed inside the Hermitage. The accesses are located on the façade's right side and next to the *Santísimo Cristo del Perdón's* chapel. Both accesses lead to a room where the public is received. This room is communicated with a small toilet and a staircase that goes to the first floor.

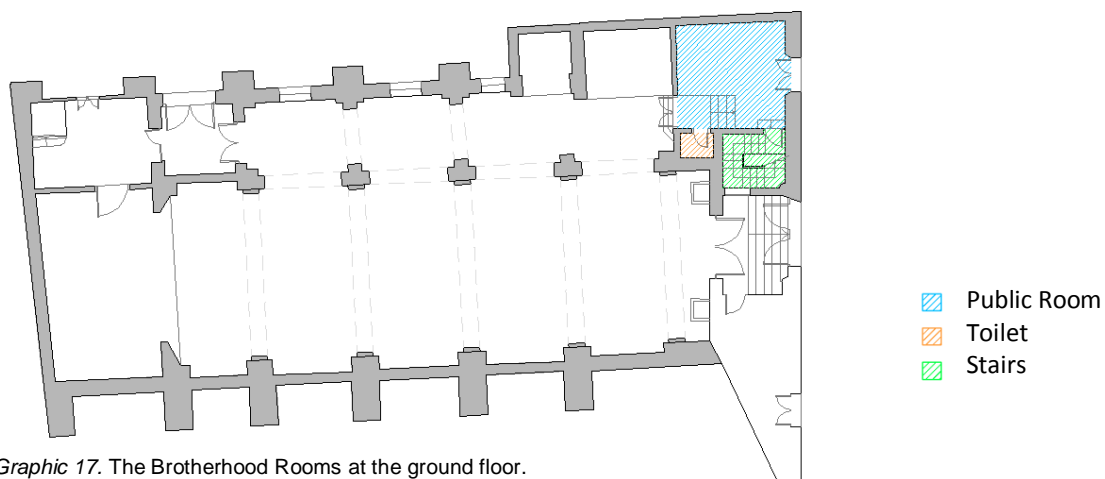

Graphic 17. The Brotherhood Rooms at the ground floor.

Going up the stairs we can find two doors: a left door that leads to the big terrace, where the bells are located; and a front door that communicates with the choir, another stairs that take to the second floor and the first floor rooms.

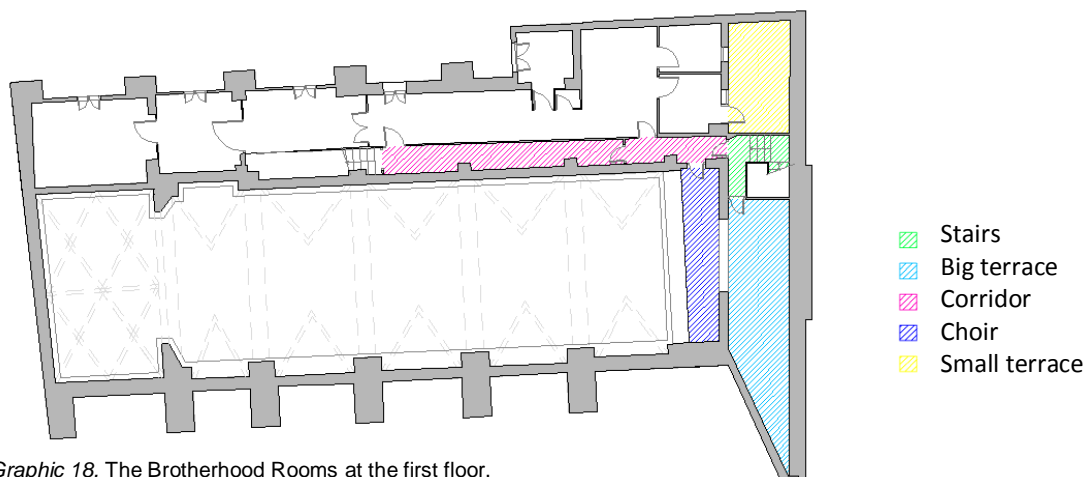

Graphic 18. The Brotherhood Rooms at the first floor.

The dining room is the first lounge. There are two doors there opened to a kitchen and a toilet. From the kitchen there's an access to the small terrace. On the right side of the dining room there's a corridor which gives access to a small closet and a room. At the end of this corridor it can be found a door that takes to an old study. From the study we access to another former room and finally to the actual Meeting Room.

In the past, there was a door in the study communicating with the following rooms by a corridor directly under the stairs. This was a way to access to the rooms without bothering the people inside by crossing them.



Graphic 19. The remaining Brotherhood Rooms at the first floor.

On arriving to the third floor we can find three doors. On the left one there's the *Bell founder Archieve*, also known as the *Sala del Gat*. This room leads to a study and the inside of the gable roof.

On the right door it is placed the Brotherhood Historical Archive, a room that holds documents and scrolls with the Brotherhood's privileges throughout history.

Finally, on the front door are located the Former Meeting Room (*Sala de Juntas*) and the Big Room (*Sala Grande*), where there was a small art museum. There it can be found a Christ sculpture from the 18<sup>th</sup> Century, the Santa Lucia's processional image, or the original altarpiece from the Brotherhood's foundation, where is showed the Saint next to *Saint Vicente Mártir* and *Saint Vicente Ferrer*. This room has also a closet on its left side.

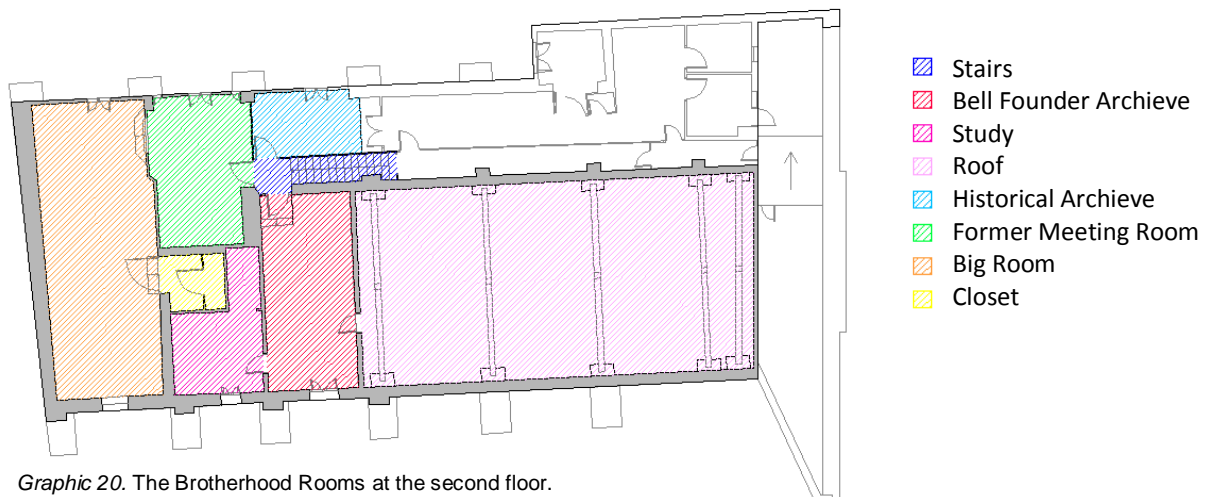

Graphic 20. The Brotherhood Rooms at the second floor.

## COMMUNICATIONS, MIXES AND SUPERPOSITIONS

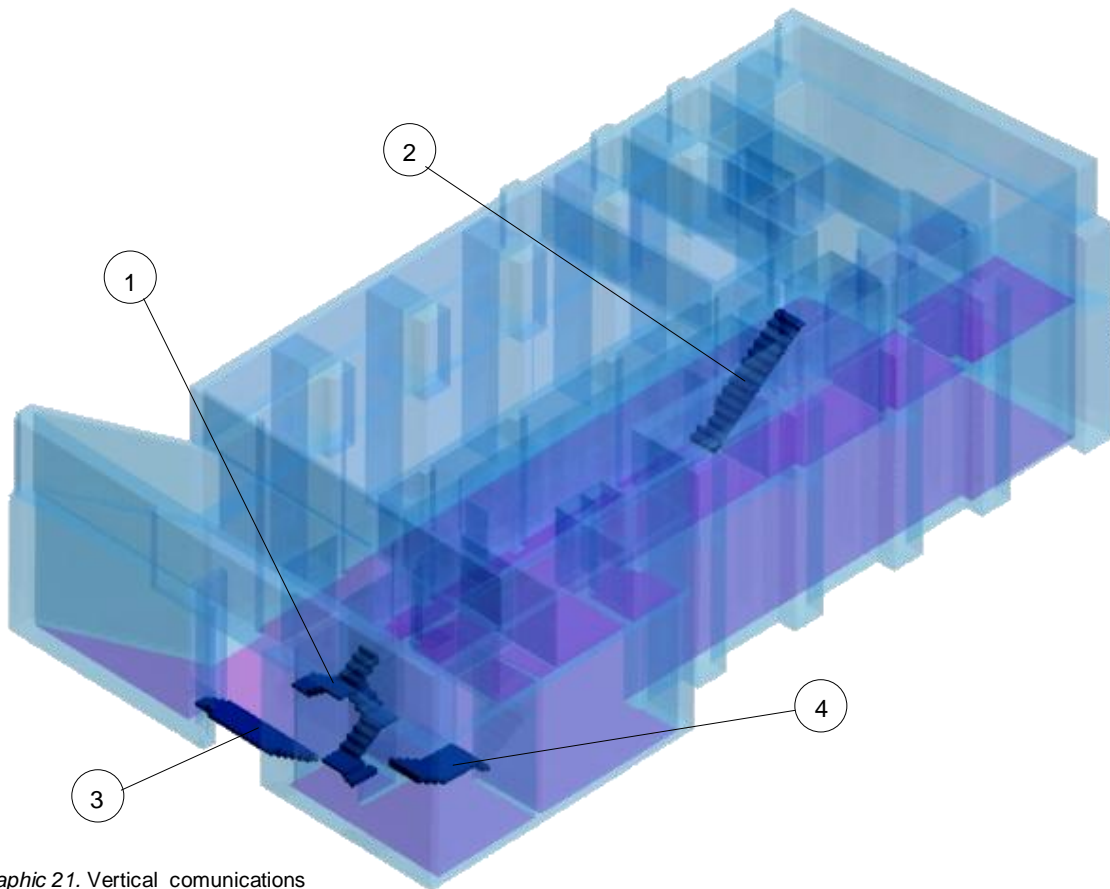

Graphic 21. Vertical communications

As it has been mentioned in the previous section, accesses to the first floor (1) and the second floor (2) are made by stairs. In the same way, in order to get inside the church there are some steps (3), as well as to access to the Brotherhood House from the inside of the church. All these stairs comprise the vertical communications of the Hermitage.

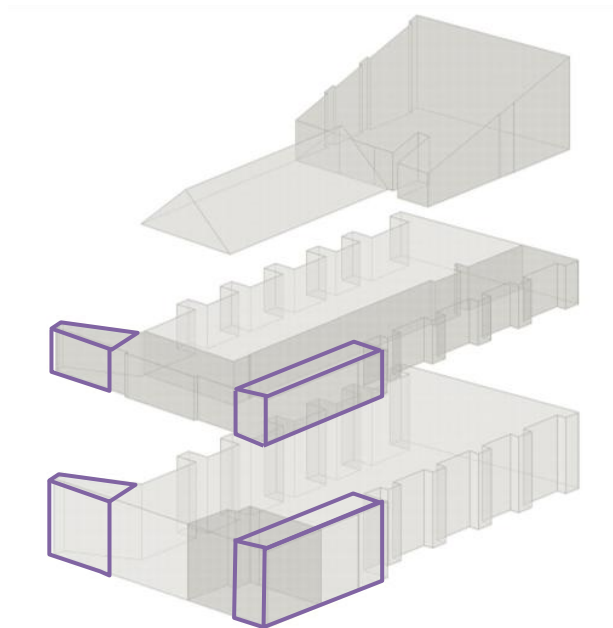

Graphic 22. Shape addition

On the other hand, analyzing the rectangular shape of the Hermitage, it can be appreciated that there are two bodies annexed to it. These two bodies, which are remarked in purple in the picture on the left, don't belong to the original shape of the building and they are considered as a mixture of the spaces.

## MODULES

Analyzing the building's composition, it's common to observe a certain connection between its elements. This is to say, there's a module relationship regarding the dimensions. However, in Santa Lucia's Hermitage any module keeps a connection with the rest of them. We can only observe a module relationship in the rectangular windows placed in the west façade:

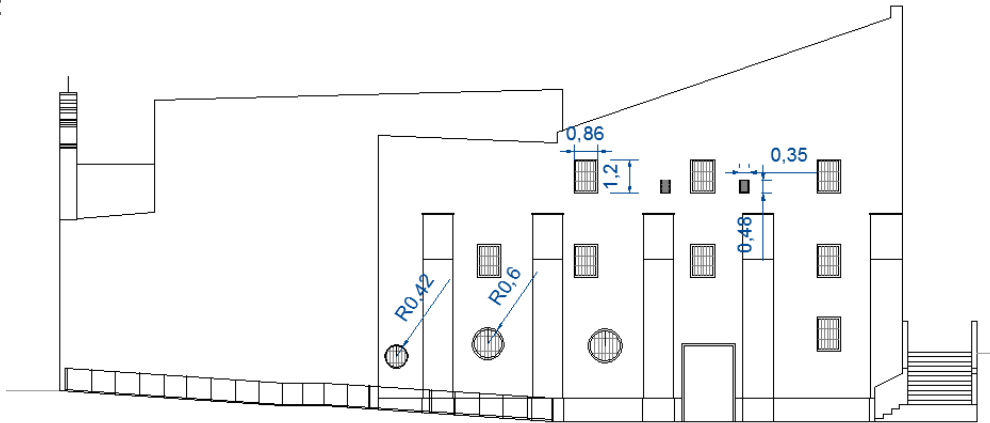

Graphic 23. Relationship between the windows in the west façade

Vertical module between rectangular windows:  $1,20 / 0,48 = 2,50$

Horizontal module between rectangular windows:  $0,86 / 0,35 = 2,50$

Module between circular windows:  $0,60 / 0,42 = 1,40$

Therefore, it's confirmed that the smaller rectangular windows are a quarter from the bigger rectangular windows. Nevertheless, this module isn't applied to the circular windows, due to their relationship is 1,40 times bigger than the smaller one.

Apart from this unique module repetition, the Hermitage doesn't have a defined module. As it can be seen, the five spaces between the two supporting walls oscillate around the 3 meters. Additionally, it can be appreciated how this distance is being reduced in a pyramidal way, almost symmetrically. It is important to enhance as well that all the pillars have the same dimensions no matter the distance they are placed.

On the other hand, there isn't either any relationship between the buttress distances, being an average of 3 meters as well. There're, though, two clear exceptions where these distances are overtaken (3,46m.) and lower (2,17 m.). This distance between buttress has an immediately consequence on the altarpieces, due to they are placed in the walls between them.

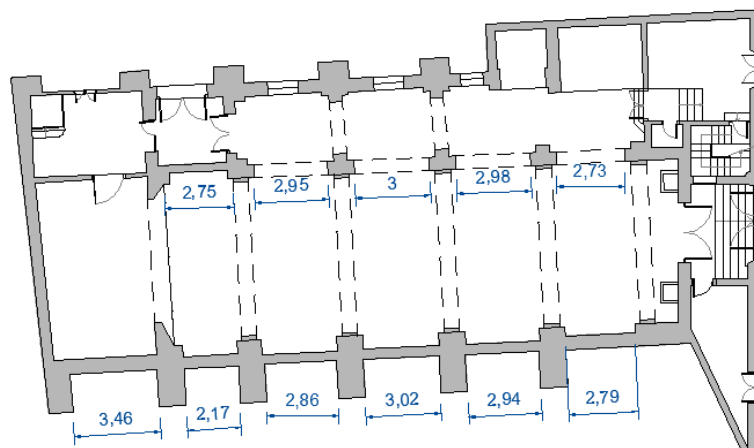

Graphic 24. Relationship between the five spaces between the two supporting walls and the buttresses

## 5. CONSTRUCTIVE ANALYSIS



## 5. CONSTRUCTIVE ANALYSIS

In order to make a constructive analysis of a building, it becomes necessary to know the materials and constructive techniques that were applied to it. As of the studies of construction history we may suppose the materials and techniques that were used in each period. Nevertheless, it's necessary to make an exhaustive research to know this data for real. Straightaway, two different techniques for get results about the type of materials a building is composed to will be explained: the *Ground Penetration Radar (GPR) Survey*, a non-destructive technique, and *Microscopy applied to façades*.

### 1. Ground Penetration Radar (GPR) Survey

This non-destructive technique is very used nowadays to obtain information about underground structures. It also gives useful information to determinate an architectonic solution in damaged buildings. In the specific case of the *Sagrado Corazón de Jesús Church*, in Spain, the objectives of a GPR survey were to analyze and certificate the existence of possible underground structures and to find out whether the origin of some structural failures, as cracks and fissures detected in the building, are related to the foundations. The GPS study was carried on in 3 areas: the east transept, the west transept and main nave.

#### ➤ Data collection

In the data collection, grids of orthogonal profiles were compiled using a GSSI SIR-10H control unit and 200 and 400 MHz antennae.

- In the **main nave**, the grid was composed by longitudinal profiles separated 3.5 m. and two transverse profiles. In the east and west aisle there were added longitudinal profiles as well. The 200 MHz antennae was used in this area.
- In the **east transept**, the grid was composed by 11 longitudinal and 12 transverse profiles.
- In the **west transept**, the grid was composed by 10 longitudinal and 5 transverse profiles. In both transepts, were used the 400 MHz antennae.

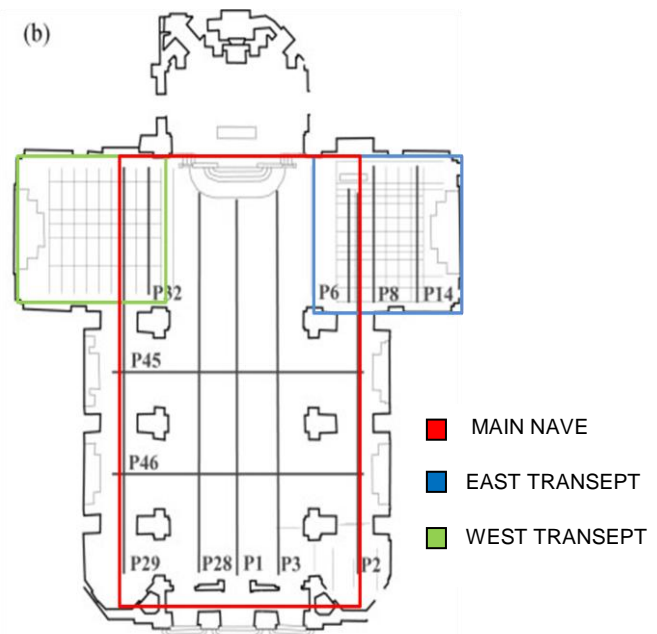

Graphic 25. Map of GPR survey profiles and grids <sup>(31)</sup>



CONSTRUCTIVE ANALYSIS

➤ Data interpretation

- In the **main nave** area it was detected a presence of a sloping substrate. The main façade of the church is near to an Arab wall's remains, so this sloping substrate could be part of its moat. The compacting difference between the moat fill and the surrounding material may have been the cause of the appearance of cracks and fissures in the floor, as well as it could also be the cause of the façade inclination.

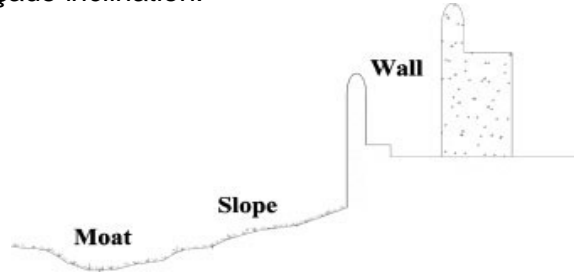

Graphic 26. Simplified representation of Arab wall in Mediterranean areas <sup>(31)</sup>

- In the **east transept** area appeared a hyperbolic reflection in several profiles. The amplitude maps constructed showed the reflections of a rectangular shape of 3.5x2.8 m. There were no records written in the past about this crypt. To confirm its presence, a flexible Lenox boroscope was inserted in a hole, and recorded images in all directions.
- In the **west side** of the transept, a shallow reflection was recorded, produced as a consequence of another undocumented grave.

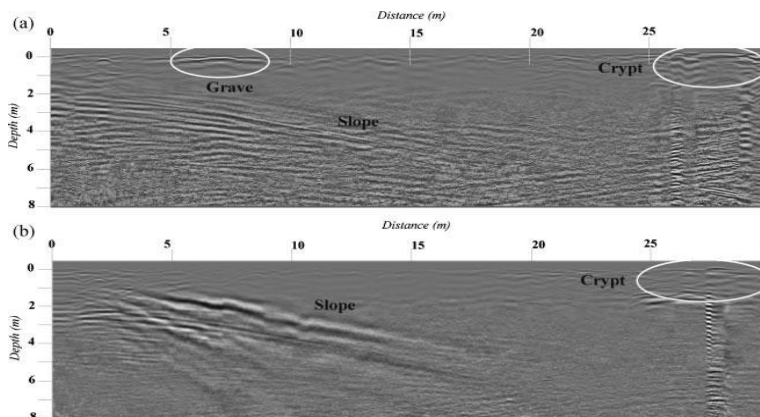

Graphic 27.  
 (a) Reflection profile P1, obtained longitudinally at the main nave;  
 (b) Reflection profile P3, obtained longitudinally at the main nave. <sup>(31)</sup>

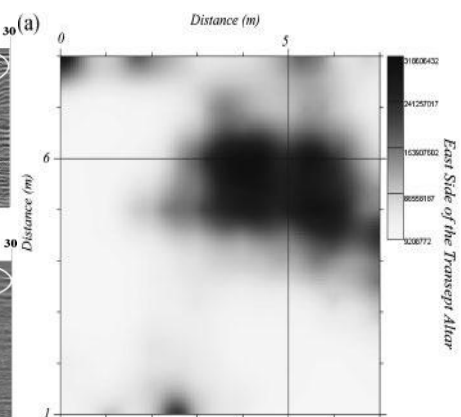

Graphic 28. Greyscale image of the amplitude time-slice created from GPR profiles collected over the east side of the transept. <sup>(31)</sup>

➤ Conclusions

The GPR survey gave information of several subfloor features that weren't known before. In addition, the survey helped to determine the causes of settling, floor cracking and the distortion of some elements.

## 2. Microscopy applied to façades

As it has been demonstrated in the Chromatic Research in *Velluters neighborhood*, it's possible to obtain by a physicist-chemical analysis the original color of the building's façades. This survey took 3 phases: the data collection, the chromatic measurement and the laboratory analysis.

### ➤ 1<sup>st</sup> phase: Data collection

An extraction of pigmented samples was made, from the areas less affected by the atmospheric agents of the façade (as the balcony's cornices or under the top eaves). There was a concern about not to cause damages by extracting the samples with an appropriate depth, so every color layer could be analyzed.

Afterwards, these samples were watered with distilled water or anticorrosive products, so it was possible to watch with the microscopy the original chromatic layer.



Picture 98. Samples taken from Quart Street <sup>(32)</sup>

### 2<sup>nd</sup> phase: Chromatic measurement

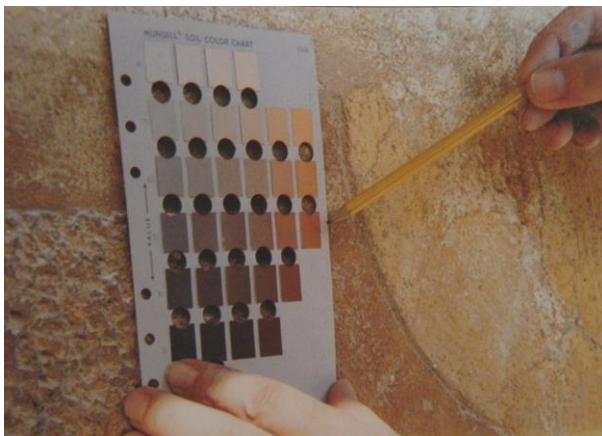

Picture 99. Visual comparison by Munsell System's Letter Color for establishing chromatic approximations <sup>(32)</sup>

There was made a cleaning of the sample's surface without modifying its chromatic characteristics. Right after, there were made observation tests, getting into the deepest surface of the walls. There were used the adequate instruments, like scalpels, special blades or thin scrapers. Finally, there were used color instrument (as the Telecolorimetry or the Photometre-Spectre) for the color measurement. As a result, the differences and values of colors were give, as well as physic and chemical terms about light and dampness.

### ➤ 3<sup>rd</sup> phase: Laboratory analysys

The pigmented samples were prepared for an optical and photographic analysis with a binocular magnifying glass and for the electronic microscopy analysis. These

CONSTRUCTIVE ANALYSIS

analyses with Electronic Microscopy were useful to know the chemical elements of the samples.

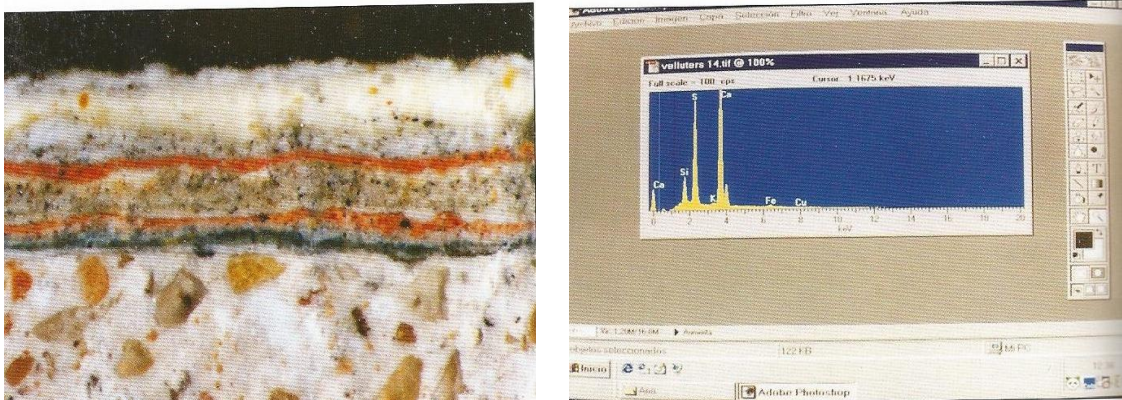

Pictures 100 and 101. Analysis where can be observed the different painting layers along the history <sup>(32)</sup>

➤ Conclusions

With this survey the chromatic letter of the Velluters neighborhood was concluded as a range of ochres. There were found rests of color green and blue as well. These characteristics were made with colored plasters or painted over a straight wall filled in with lime mortar. The study allows recovering the original color of the neighborhood.

## BASIC TECHNIQUES. CONSTRUCTIVE EVOLUTION

### Valencian's Mud Wall

*Valencian's Mud Wall* is a constructive masonry technique that assumes as a basic material the soil. This technique achieves not only the necessary material cohesion in order to guarantee its resistance and durability, but also a permanent superficial finish. It allows the wall's conservation without regular maintenance, showing at the same time a decorated and stable finishing. All of that is obtained with only one material application.

#### Constructive Process

Once the foundations are executed, the first part of the wall to be constructed is a baseboard. It can be made by different materials, such as bricks, stones or punctured crust. Afterwards, it was proceed to build the *Mud Wall* can be constructed. Once located and aligned the doors, the filled up and compacted process of the wall was initiated. The following phases were made successively for that:

1. A concrete line was placed next to the door.
2. The bricks were put over the concrete next to the door.
3. A soil layer with the same thickness as the concrete and bricks was spilled and smashed. This way the whole layer stayed flattened.

The compacting was made starting from the middle to the doors, compressing against the bricks. Once compressed the *Mud Wall's* heart is compressed, the brick was hit in order to be flattened into the concrete. This hitting caused a mass vibration having two effects: on the one hand the brick's sliding to the interior, and on the other hand a partial lime grout recover of the space left by the bricks next to the doors. That's the reason why this filling between bricks is ahead of them, which remain sunken in relation to the frontal surface of the wall.

The last phase to execute in this kind of walls was the crown, generally done by making roof cornices with brick and plaster

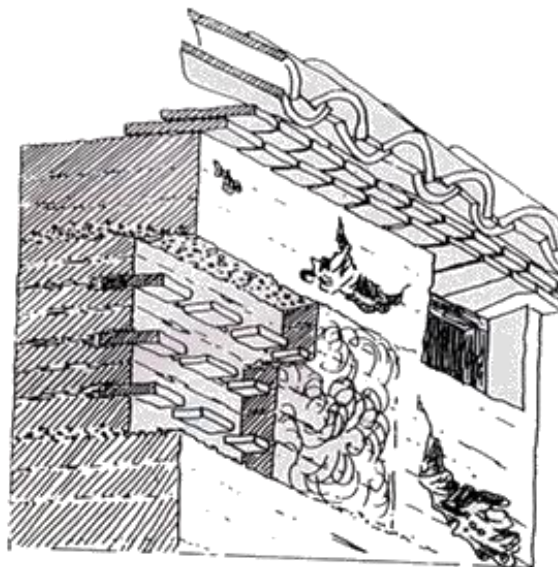

Graphic 29. Example of a Valencian Mud Wall <sup>(34)</sup>

## FOUNDATIONS

There are no evidences about the type of foundation the Hermitage has. Nevertheless, the foundations built in the same period were made by gravel aggregates with a mortar bath, covered by *morrillos* surface. The pillar's foundations were isolated and they joined the wall's foundations, forming a kind of frame (reinforcing grid). Therefore, it's assumed that's the way the Hermitage's foundations are composed of.

At the refurbishing works which were carried out in 2012, there was observed a longitudinal crack in the left side of the principal façade. This left section was added in 1925, when the actual façade was built. This crack was the causes of a lack of fasten between this new section and the rest of the façade, in addition to the drop of the section. The origin of the settlement was the flow of a water line right under the foundations, which were seriously damaged and almost entirely destroyed.

## STRUCTURE

The elements which will be analyzed in the Structure section are the pillars, the floor structures and the principal nave vault.

The **pillars** of Santa Lucia's Hermitage are made by solid bricks covered by air lime mortar. There are a total of seventeen pillars in the building, placed as it can be observed in the picture below.

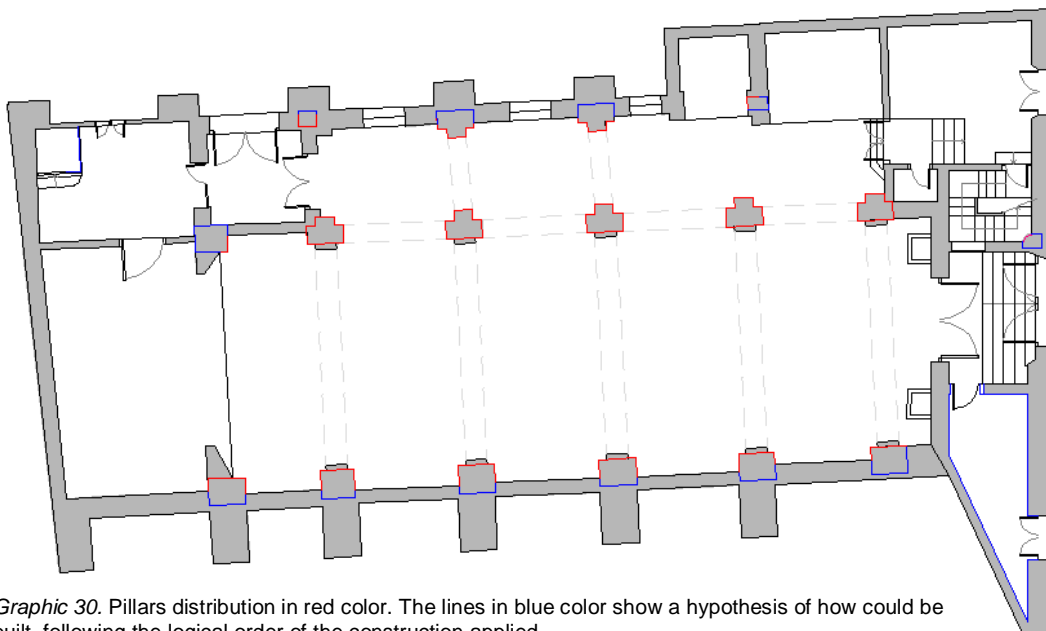

Graphic 30. Pillars distribution in red color. The lines in blue color show a hypothesis of how could be built, following the logical order of the construction applied.

CONSTRUCTIVE ANALYSIS

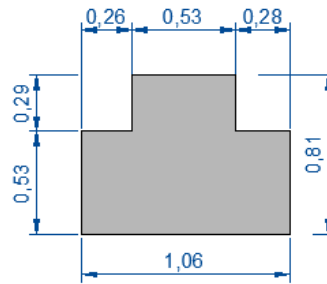

Graphic 31. T shape pillar's dimensions

As for the **floor structures**, there are three different kinds of them in the Hermitage. However, there're just evidenced of two of them: the laminate floor structure and the interior vault floor structure.

The *laminate floor structure* is situated above the main nave of the church in the room named as the *Bell Founder Archive*. This kind of floor structure was executed because the floor couldn't rest its weight over the nave. Therefore, two longitudinal wood beams support three metallic sections, where the laminate floor rests on.



Pictures 102 and 103. Laminate floor and longitudinal wood beam

The *interior vault floor structure* is placed in the rooms named as *Former Room* and *New Meeting Room*, in the first floor of the Brotherhood House. They are dated on the 18<sup>th</sup> and the 19<sup>th</sup> Centuries respectively. This system works the following way: a one layer brick vault chases the directional of a low arch between two joists. This small vault gives support to the filling, which on being straighten with the two joists constitutes a horizontal surface. The joists have a rectangular shape and have different dimensions in each room.

CONSTRUCTIVE ANALYSIS



Pictures 104 and 105. Interior vault floor structures (18th and 19th Centuries respectively)

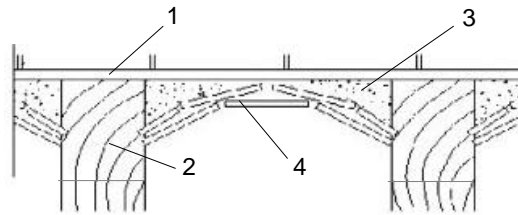

Graphic 32. Interior vault floor structure:

1. Pavement
2. Wooden joint
3. Filling by different materials
4. Forming the vault bricks.

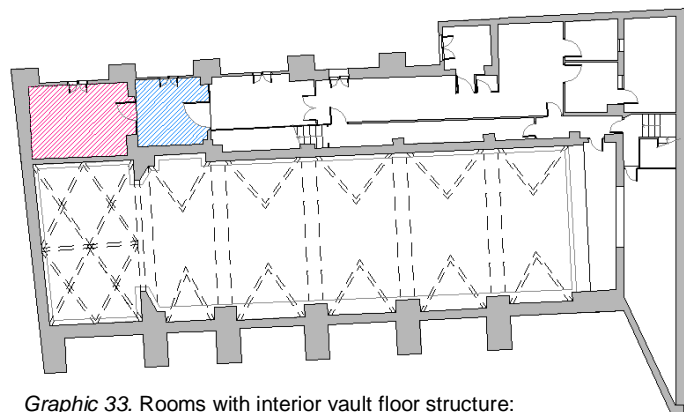

Graphic 33. Rooms with interior vault floor structure:

- Study
- New Meeting Room

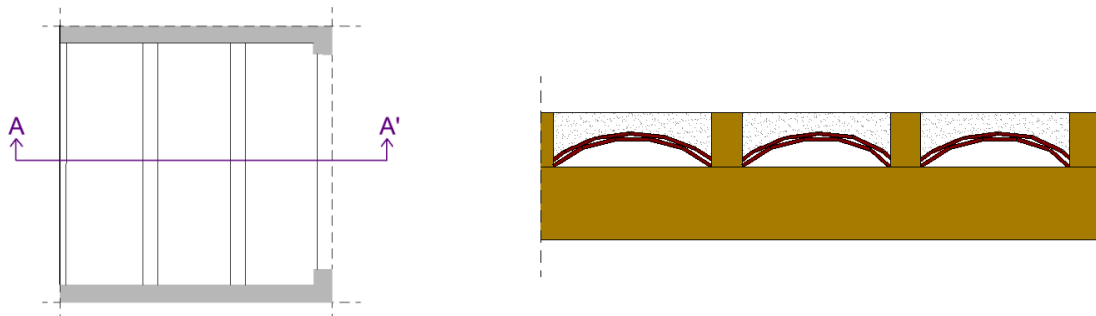

Graphic 34. Study: Ceiling view and A-A' Section

CONSTRUCTIVE ANALYSIS



Graphic 35. New Meeting Room: Ceiling view and B-B' Section

The **principal nave vault** is made by three solid big plane bricks sheets placed plainly regarding the interior. The first of the sheets is taken with plaster, and the other two are taken with mortar. These types of vaults are self-carrying and they didn't need any wood shuttering.

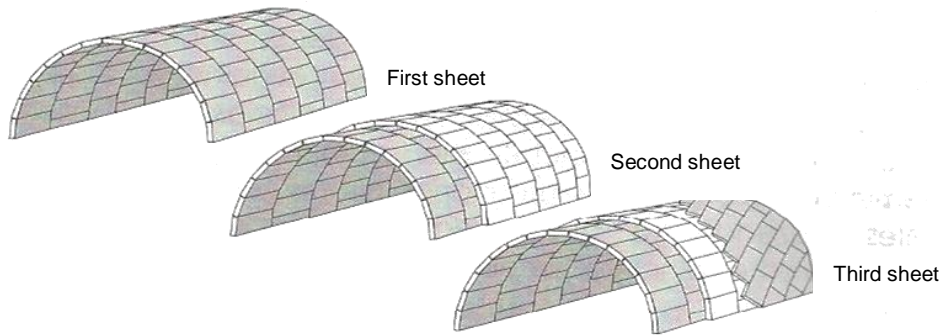

Graphic 36. Three sheets brick up wall <sup>(33)</sup>

The entire Hermitage's **staircases** are made the same way as the barrel vault is: by three solid big plane bricks sheets placed plainly regarding the interior. The first of the sheets is taken with plaster, and the other two are taken with mortar. This vault is previously redesigned in the wall it's going to be supporting. When the vault is finished, the steps are built over it, and lately covered by granite pavement.

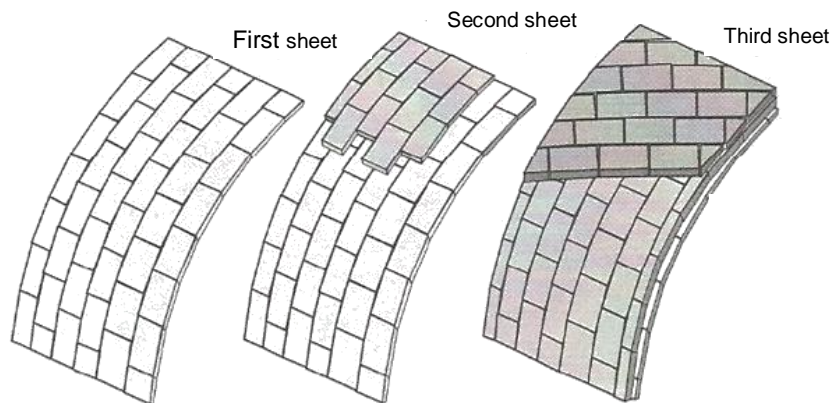

Graphic 37. Three sheets brick up stair's vault <sup>(33)</sup>



CONSTRUCTIVE ANALYSIS

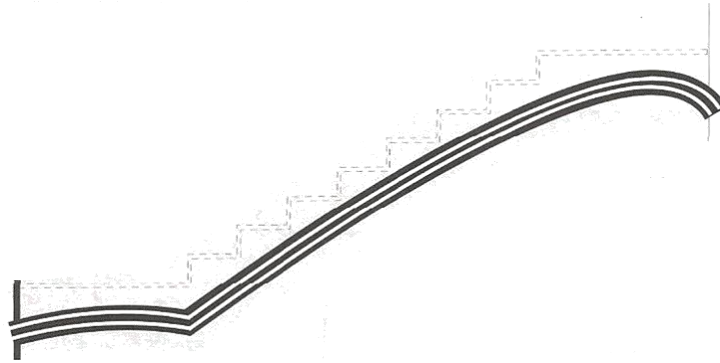

Graphic 38. Brick up vault's outline and construction <sup>(33)</sup>



Pictures 106 and 107. Stairs steps and vault

WALLS

There are two different types of **walls** located in the Hermitage. The first and most common one is made by, and covered by air lime mortar, just as the pillars. This technique is adopted in almost all the walls, being its thickness modified depending on where they are placed.

The second type of wall is the *Valencian's Mud Wall*, which has been already explained in the *basic techniques. Constructive evolution* section. This kind of wall is just executed in the south façade of the Hermitage.

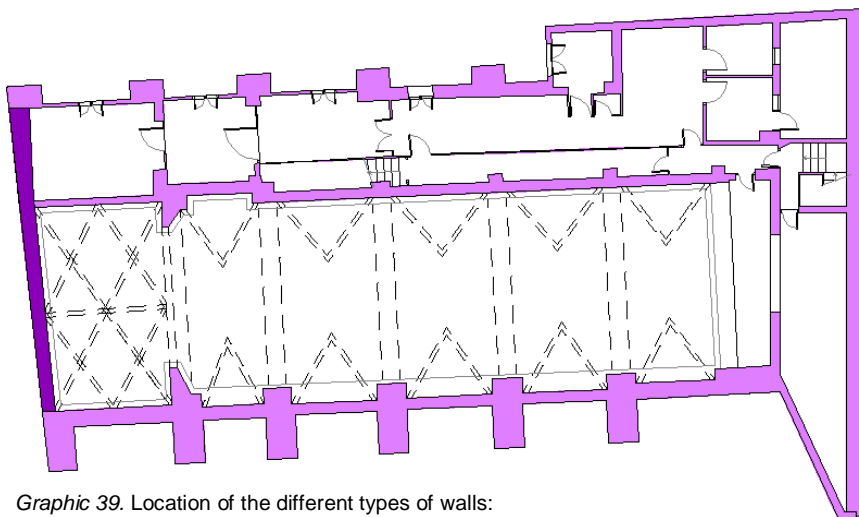

Graphic 39. Location of the different types of walls:

- Valencia's Mud Wall
- Solid brick wall

CONSTRUCTIVE ANALYSIS



Pictures 108 and 109. Brick walls on the west and north façades respectively <sup>(39)</sup> <sup>(40)</sup>

All **vertical covering** techniques in the dry rooms of the Brotherhood House are made by plaster over the brick walls. Over the plaster, there's a painting layer. It's also remarkable the fact that the entire ground floor is covered by a **ceramic skirting board**, with one meter of height.



Pictures 110 and 111. Covering materials in the dry rooms

As for the covering materials in the wet rooms (such as the kitchen and the two toilets) of the Brotherhood House regard, they are filled with mortar over the bricks. Then there's a glue cement layer, which holds the ceramic floor tiles.

## CONSTRUCTIVE ANALYSIS



Pictures 112 and 113. Covering materials in the wet rooms

On the other hand, the exterior of the Hermitage is entirely covered by filling them with mortar over the bricks and the *Valencian's Mud Wall*. Over the mortar, there's a painting layer.

## ROOFS

There are a total of four roofs in Santa Lucia's Hermitage: three of them are shed roofs and the fourth one is a gable roof.

The three **shed roofs** are respectively placed over the rooms of the second floor, the rooms in the first floor, and the accessing to the first floor stairs. In the one over the first floor rooms it's placed a skylight.

They are composed by an inclining framework of wood joists (common rafters) which rests transversely over two walls. For better support conditions, these common rafters are situated over a pole plate, which guarantees its stability thanks to a joist sill. Over the common rafters, there're placed longitudinal little wood joists named as purlines, where a wood board rests. The function of this wood board is to be used for putting the tiles.

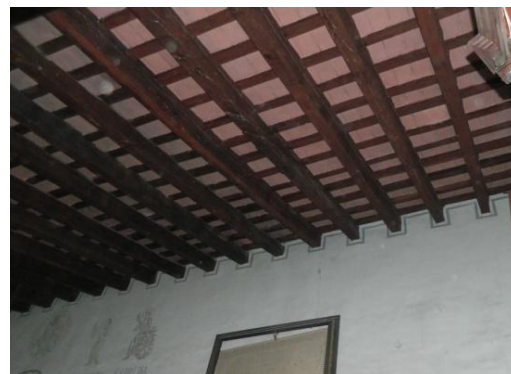

Pictures 114 and 115. Shed roof over the second floor rooms

CONSTRUCTIVE ANALYSIS

The **gable roof** is placed over the principal nave of the church. It is made by wood trusses which rest on the pillars. However, there must have been a dimensions mistake regarding the trusses, because they don't always lay in the center of the pillars, being in some occasions in its edges.

The framework these trusses are composed of is the following one: the common rafters, placed transversely to the pitch, rest on the trusses. The purlines are placed over the common rafters in the maximum pitch direction, and they support the wood board, a surface where the tiles are situated. The underlayment was achieved by applying a mortar layer, which holds the tiles.



Picture 116. Wood truss resting over a pillar <sup>(35)</sup>



Picture 117. Gable roof <sup>(36)</sup>



Picture 118. Ridge view <sup>(37)</sup>

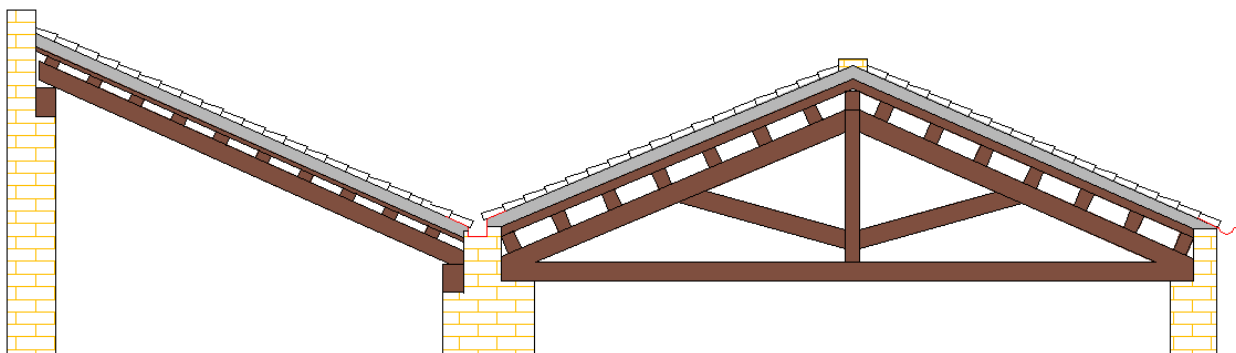

Graphic 40. Construction of the shed roof and the gable roof

## CONSTRUCTIVE ANALYSIS

On the other hand, there are two **gutters** in the roofs: the first one is a box gutter placed between the gable roof and the shed roof over the first floor; the second one is placed on the other side of the gable roof.



Pictures 119 and 120. Box gutter on the left picture and gutter in the picture above <sup>(42)</sup>

## WOODWORK

In regards to the Hermitage **doors**, they all are hardwood. The three ones in the main façade are covered with a metallic sheet, with the purpose of avoiding dampness and sackings. Some doors have also stained glass, as it can be seen in the one placed in the hall that precedes the church in the main entrance.

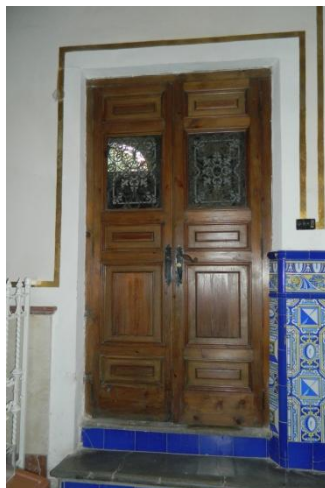

Pictures 121, 122 and 123. Different kinds of the Hermitage's doors (covered with metallic sheet, with stained glass, and plane)

On the other hand, the **windows**, as same as the doors, are hardwood and they are covered by lattices. The great part of them are folding windows and have rectangular shape. Nevertheless, there are also three circular windows in the west façade, and an oval window in the east façade.

CONSTRUCTIVE ANALYSIS



Pictures 124, 125 and 126. Different kinds of the Hermitage's windows. From left to right: rectangular, circular and oval shaped (5)

SINGULAR ELEMENTS

Pavements

There are many different and interesting types of pavements in the Hermitage, as the industrial concrete pavement, the hydraulic pavement, wood pavement and the ceramic brick pavement.

The **industrial concrete pavement** is placed in the interior of the church. It's made by a concrete later with a thickness of 6 to 10 cm., with grey and black colors from the 1920s.

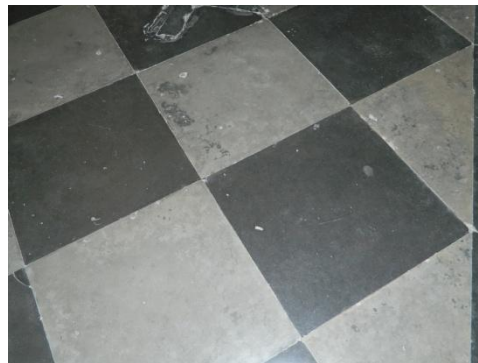

Picture 127. Industrial concrete pavement

The **hydraulic pavement** is placed along some rooms of the first floor. This kind of pavement is made by pigmented cement floor tiles.



Pictures 128 and 129. Hydraulic pavement

## CONSTRUCTIVE ANALYSIS



Picture 130. Wood pavement

The **wood pavement** is placed in the room named as *The Bell Founders Archive*, in the second floor. It consists on thin and long wood laminates collocated over a wood floor boarding and supported by metallic U profiles.

The **ceramic brick pavement** is placed in the rooms of the first floor named as *Former Room* and *New Meeting Room*, as well as in the *Big Room* placed in the second floor. The ceramic bricks form a drawing, being the biggest in the center, and surrounded by four smaller pieces.



Picture 131. Ceramic brick pavement

## 6. PATHOLOGICAL ANALYSIS





## 6. PATHOLOGICAL ANALYSIS

### PATHOLOGICAL HISTORY

---

The chronological study of pathologies in a building is an interesting and useful task for interpreting some lesions, because they may be consequence from previous refurbishments wrongly executed.

- 1860, August 2<sup>nd</sup>:** the actual façade is built by the architect Mr. Sebastián Monleón.
- 1865:** the belltower is added by Luis Peseto.
- 1911:** Hermitage's refurbishment thanks to the Brotherhood member Mr. José Vivó Cervera.
- 1921:** the refurbishment works continue by artists Mr. Francisco March and Mr. Vicente Jerique.
- 1925, August 25<sup>th</sup>:** façade's refurbishment by the architect Lorenzo Criado.
- 1957:** partial refurbishment of the church.
- 1968, November 24<sup>th</sup>:** partial refurbishment of the church. It is agreed that the Brotherhood subscribes two parts and the catholic church a third one. The artist Mr. Francisco Sambonet is given 160.000 pts.
- 1976, March 15<sup>th</sup>:** application to the council for a dampness correction.
- 1981:** Refurbishing works of the surroundings designed by the Secretary of Culture as a result of the demolishing of the Old Hospital and Medicine University. The works were directed by the architect Mr. Álvaro Gómez Ferrer (5.000.000 pts.)
- November 27<sup>th</sup>:** the major altarpiece is submitted to a treatment against termites (1.450.000 pts of taking the piece and 190.000 pts of treatment).
- 1996:** refurbishment of the presbytery wall (497.500 pts the first phase and 961.999 pts the second one) given by the Council of Culture and Heritage.
- 1998:** Mr. José Arnau's refurbishment company paints the Presbytery (1.200.000 pts).  
New electric system (2.000.000 pts).
- 1999:** principal access handrail (350.000 pts).
- 2003:** The refurbishment works of painting the lateral nave and the altars continue.
- 2004:** it's agreed to finish the following works by the 1.700 anniversary celebration of Santa Lucia's martyrdom:
- Golden refurbishings and painting
  - Major altarpiece golden front
  - New reliquary front
  - San Juan of Ribera's altarpiece
  - Santa Águeda's refurbishment

- Images cleaning
- Stained glass windows's refurbishment
- Lamps refurbishment
- Electric and sound system
- Building work
- Wood carvers

Final budget: 74.126 Euros

**2005:** low voltage system against pigeons (10.904 euros).

**2008:** urgent works basic project by the architect Mr. Salvador Vila (617.363 euros).

**2009:** refurbishing works for changing a gable roof beam.

**2010:** Connection works to the sewage. Structural façade and terrace works entirely financed by the Brotherhood House. Work director architect: Salvador Vila. Company: Construcciones RIPOLLÉS S. L. (Sagunt).

**2012:** Exterior refurbishing and lateral accessibility works.

### Pictures from the most important refurbishment works:

1. Low voltage system avoiding pigeons (2005)

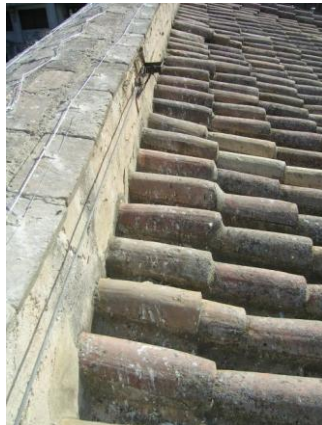

Picture 132. Ridge system <sup>(42)</sup>



Picture 133. Starter tile system <sup>(43)</sup>

2. Change of a gable roof beam (2009)



Picture 134. Former wood beam struted <sup>(44)</sup>



Picture 135. New wood beam <sup>(45)</sup>

### 3. Connection to the sewage (2010)



Picture 136. Street excavation <sup>(46)</sup>



Picture 137. Sewage Works <sup>(47)</sup>

### 4. Exterior refurbishing and lateral accessibility (2012)



Picture 138. Scaffolding on West façade <sup>(48)</sup>



Picture 139. Lateral Access <sup>(48)</sup>

## SURROUNDING CONDITIONS

Before starting to study the pathologies, it is also important to analyze the Hermitage's surroundings, as well as its orientation, the exposure and environmental conditions. All these facts have been affecting the building's physical conditions during its entire life.

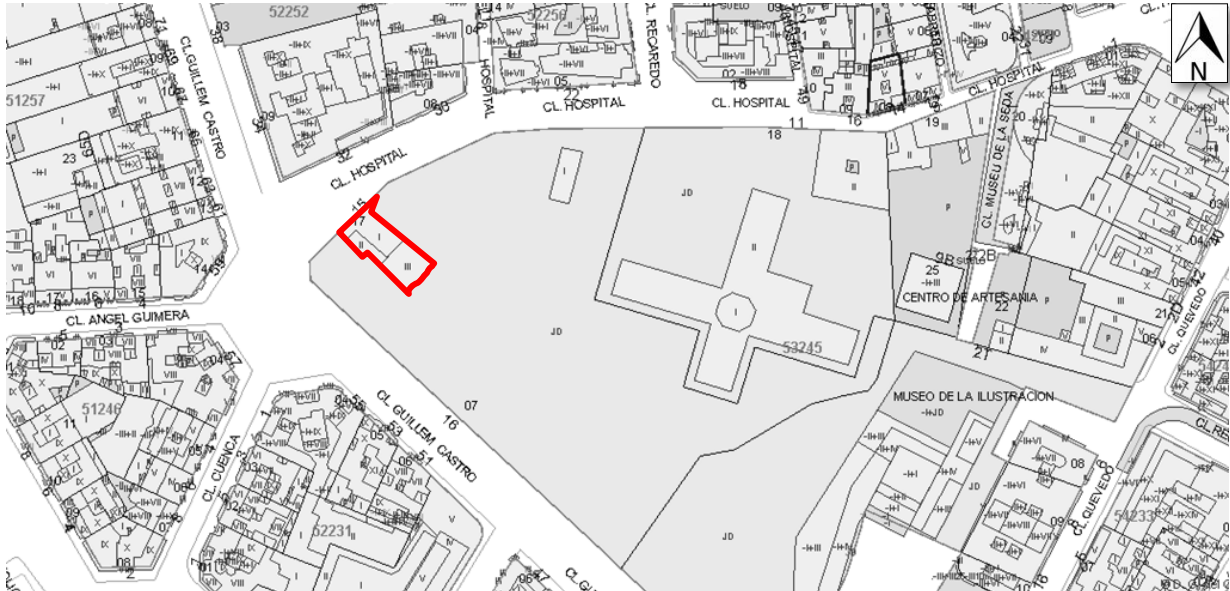

Graphic 41. Santa Lucia's Hermitage surroundings cadastre map

In the cadastre map, it can be observed the orientation and the position of the Hermitage. It's a free-standing building, whose north façade happen to be the principal one, while the south façade is the back one.

On its north side, the Hermitage is surrounded by buildings that reach a total of ten floors in the small *Hospital Street*. Meanwhile, its south façade is open to gardens with exuberant vegetation, where the Hospital Library is placed. Many ruins from ancient edifications were recently discovered in the gardens area.

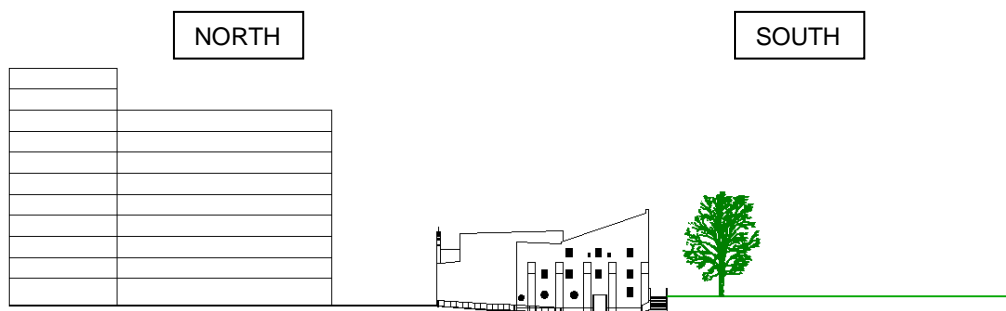

Graphic 42. North-South Hermitage surroundings

On the west side, the Hermitage leads to a small intermediate garden between the building and *Guillem de Castro Street*. In the mean time, the east façade has views to large gardens with exuberant vegetation.



Graphic 43. West-East Hermitage surroundings

Assuming that all façaces are unprotected, the Hermitage orientation became a good thing because it has protected the North façade from the winds.

As for the weather the Hermitage is exposed to, the Valencia city climate is Mediterranean. It has soft winters and warm summers, being August the hottest month in the year and January the coldest one. The precipitations are slender and irregular, and they are usually concentrated in October and November.

Therefore, as it can be seen in the graphic below, the highest temperatures (TM) the south façade is exposed to go around the thirty degrees. On the other hand, the lowest temperatures (Tm) in the north façade the coldest moths don't rise more than the seven degrees.

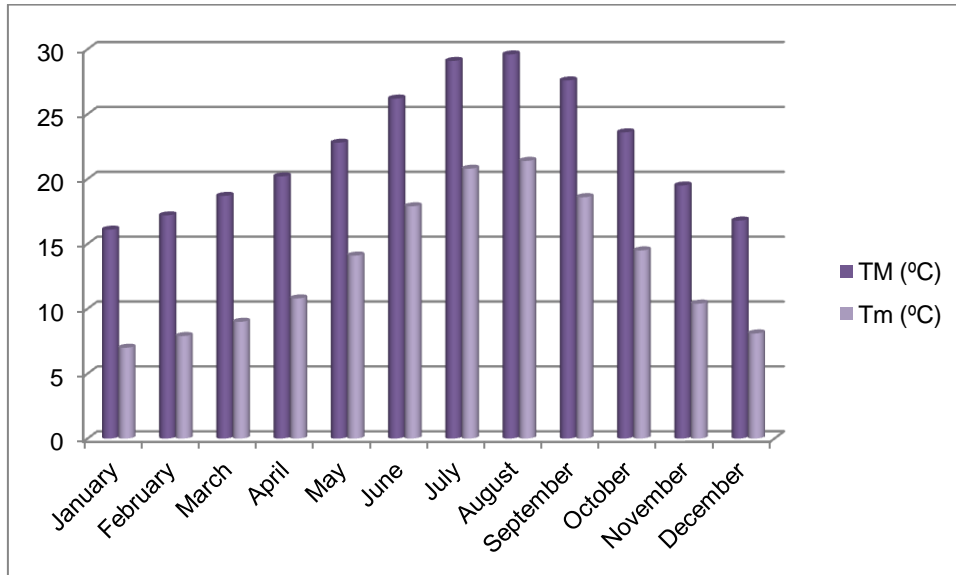

Graphic 44. Maximum and minimum temperatures in Valencia <sup>(49)</sup>

Santa Lucia's Hermitage is placed in the historical center of the city. It isn't exposed to an aggressive chemical environment; the only element that affects it is the *Rovella's water line*.

In the present times, the water line crosses to the left side under the new river channel and flows along a new subway route until it joins the former line. This irrigation canal goes through the city's sewage system and emerges in the *Valladar's water line*,

placed in the irrigated area known as *Huerta del Pou d'Aparisi*. Therefore, the *Rovella's water line* flows under Guillem de Castro Street, where the Hermitage is placed.

The main utility of this system was as a historical sewage of the city until 1975, when the new collectors were installed. Its waters dragged the city black waters in order to use them as an irrigated areas used for cultivation fertilizer. Nowadays, part of the route is still used to this purpose, although it isn't really known the quantity of these spills.

In the following city map there's marked in brown the channel of the *Rovella's water line*. The red circle makes reference to the Hermitage's position.



Graphic 45. Rovella's water line channel. The Hermitage is circled in red <sup>(50)</sup>



Section 1



Section 2



Section 3



Section 4



Section 5

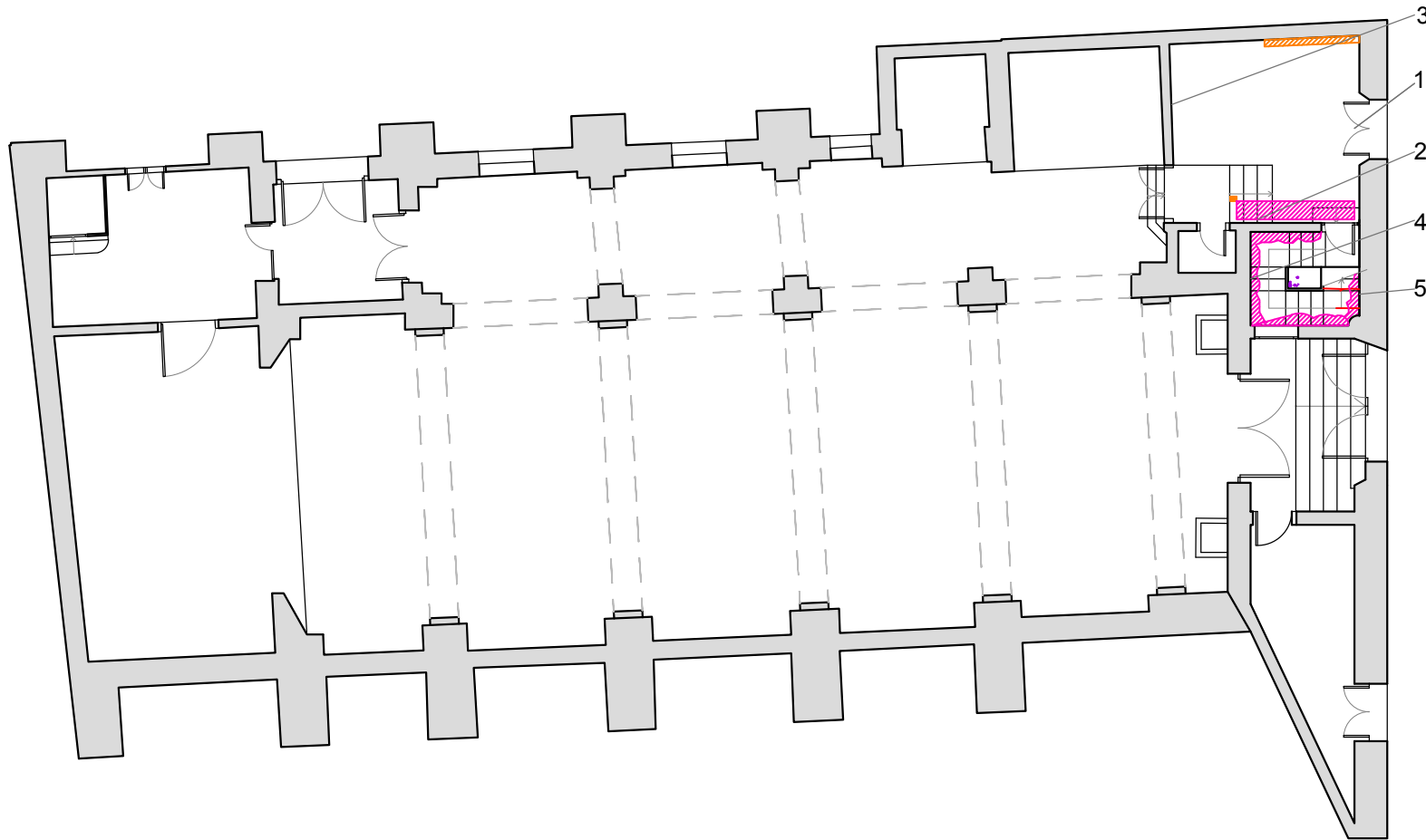

- Dampness
- Flaw
- Lack of material
- Mutilation
- Craks
- Rotting





Section 6



Section 7



Section 8



Section 9

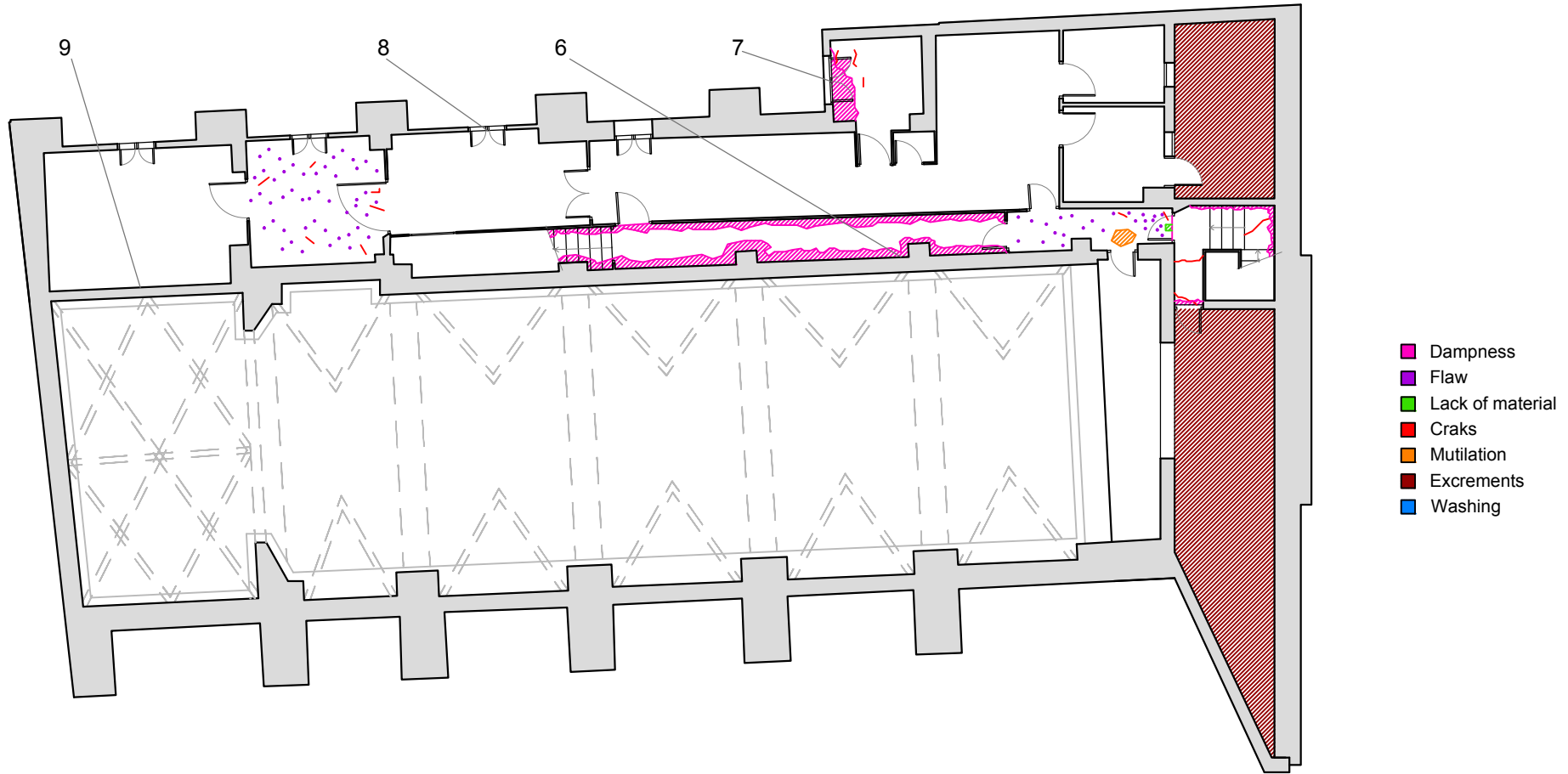

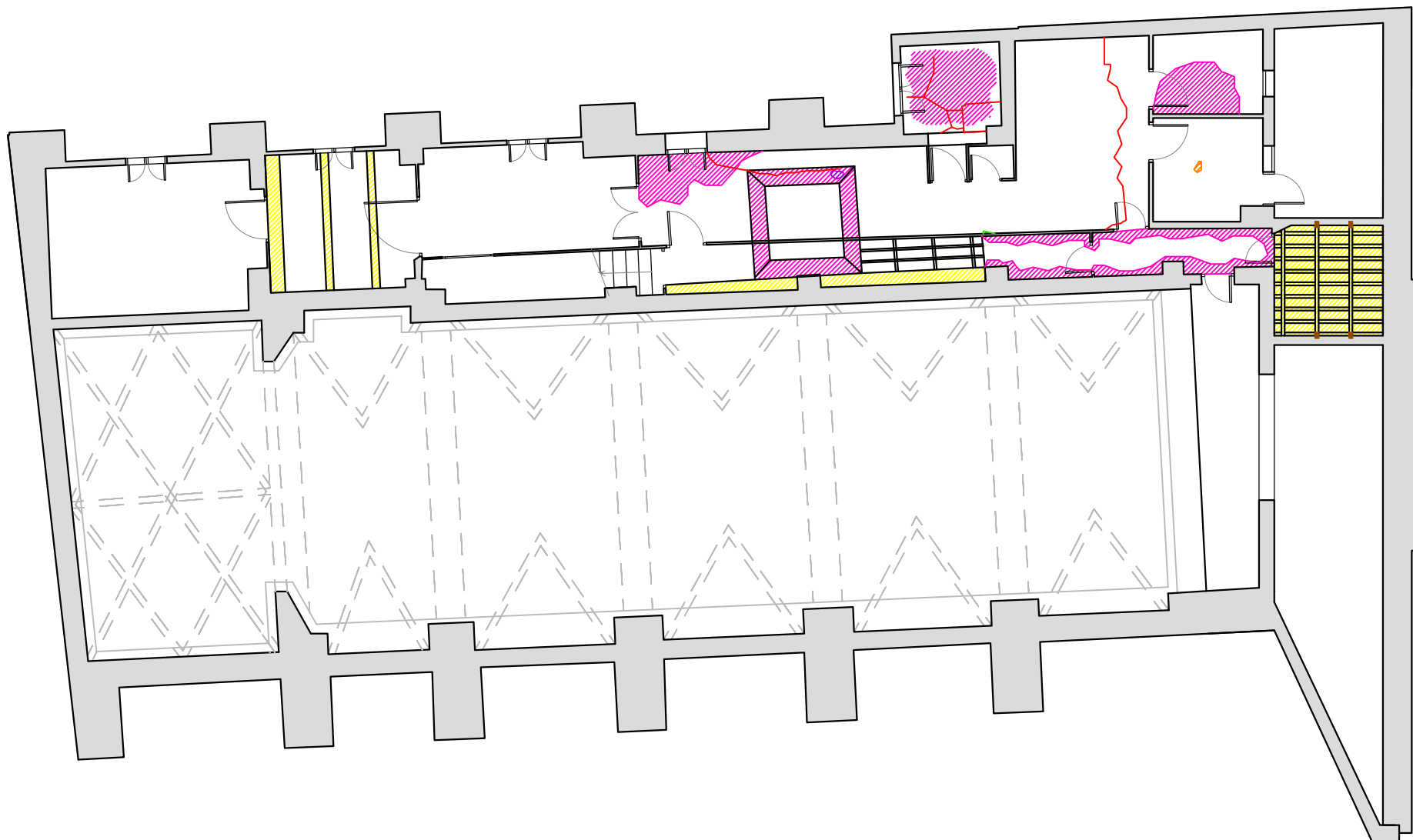

- Dampness
- Flaw (desconchado)
- Craks
- Inflorescences
- Mutilation
- Lack of material
- Rotting



Section 10

- Dampness
- Flaw (desconchado)
- Craks
- Washing

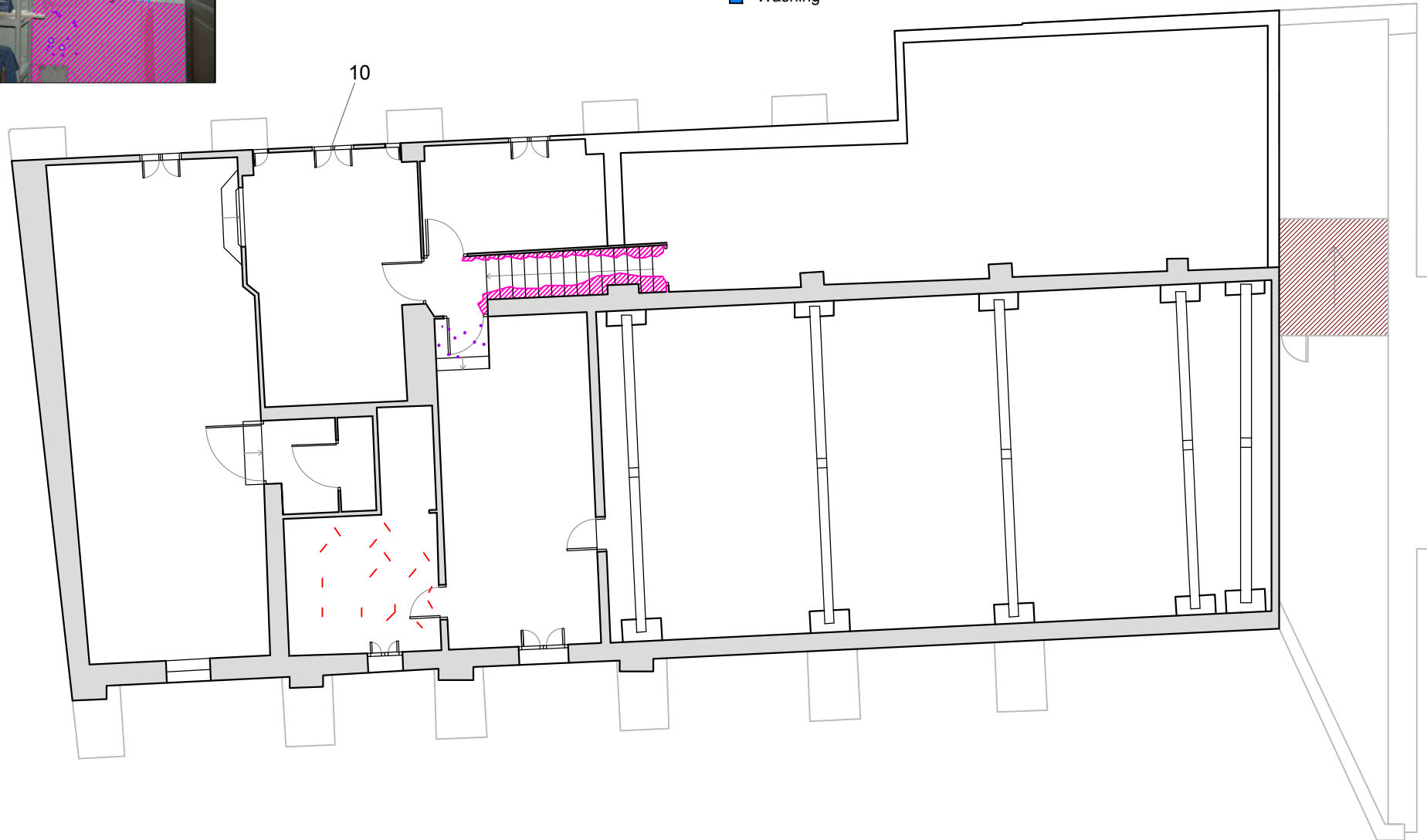

- Dampness
- Flaw (desconchado)
- Craks
- Inflorescences

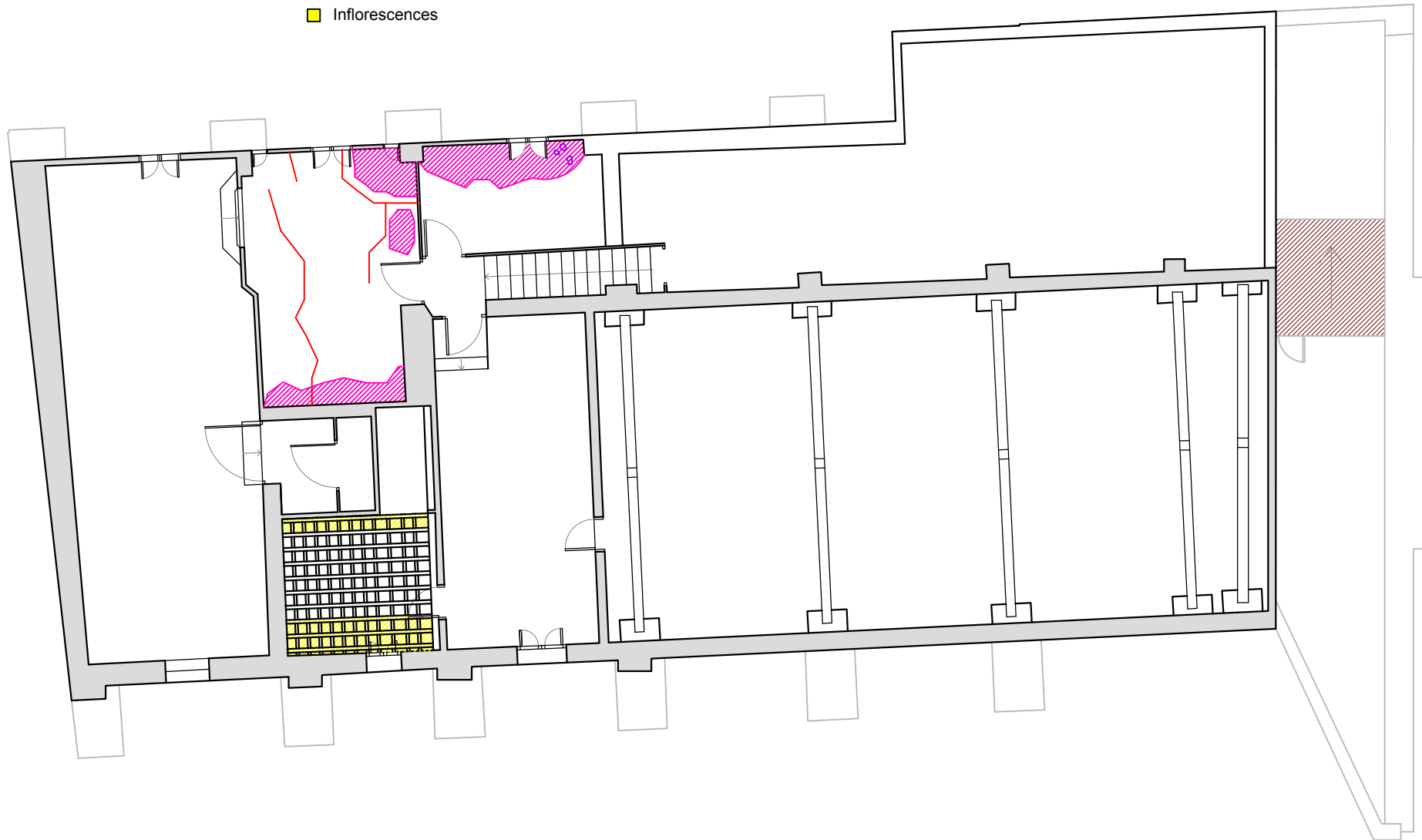

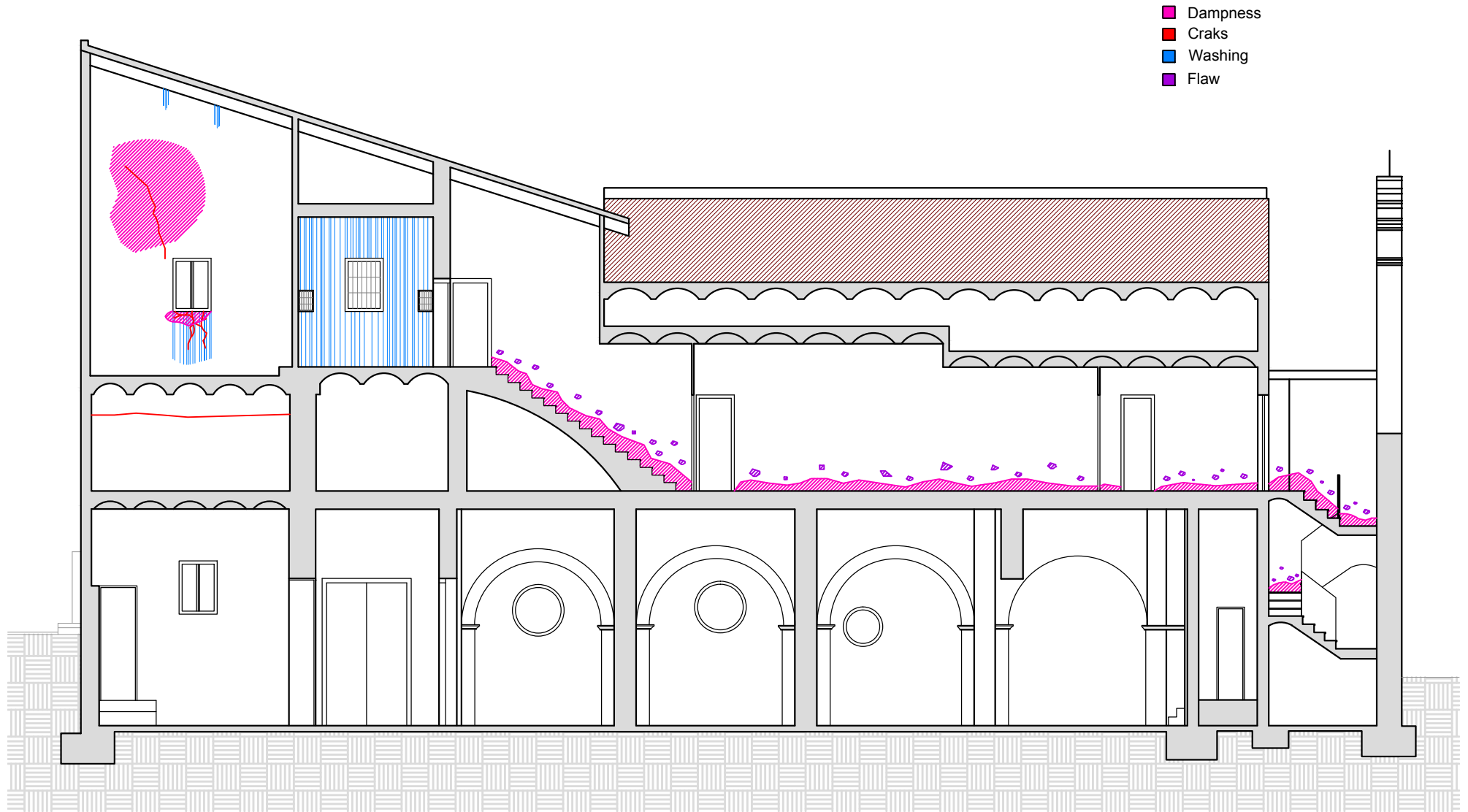

- Dampness
- Craks
- Washing
- Flaw

## PARTICULAR STUDY OF DAMAGES

### 1. PEELING OFF OF MATERIAL



Picture 140. Loosening of the covering material

**Location:** room whose access is placed on the lateral right door of the main façade.

**Pathology definition:** as it can be observed, the covering material has become detached along the metallic lintel put on top of the wood beam.

This situation may be caused due to the lintel is supporting more weight than it's able to absorb. On supporting that much weight, it ended up bending and, consequently, the covering material that was situated over the lintel and the beam has been came off. As can be seen through the pictures, the lintel only supports one part of the load bearing wall (about 30 cm. from the 60 cm of its total thickness), because the other section rests over the layer of solid bricks brick forming the arch-shaped window.

Besides, in the Wood beam can be detected rests of the lime coming from the covering material.

The long term consequence of this lesion may create is the beam's degradation on being unprotected. In the same way, if the weight the lintel supports is very excessive, it may even collapse.



Picture 141. Metallic lintel bended over the Wood beam

## 2. VERTICAL CRACKS AND EMPTY JOINTS



Picture 142. Vertical crack on the brick wall

**Location:** in the corridor whose access is placed the way to the stairs to the first floor, next to the second pillar.

**Pathology definition:** as it can be appreciated, the crack increases their thickness just as it ascends, this is to say, it diminishes its section in the lowest part. It can be also seen how the crack starts very close to the pillar and moves away in a diagonal sense when it descends. This is due to a building movement in the opposite direction.

On knowing a water line crosses the Hermitage underground, it is very possible that the building settlement comes from the foundations, because they may have been affected by the waterline.

In the pictures it can be observed how the cracks have originated a lack of joints between the bricks. Furthermore, the appearance of the cracks has also cause the loosening of the covering material around the area.

The lesion long term consequences depend on the cracks state: if they are still alive, it would be necessary to reinforce the foundations in order not to aggravate the situation; if the crack isn't alive, there wouldn't be an important incidence

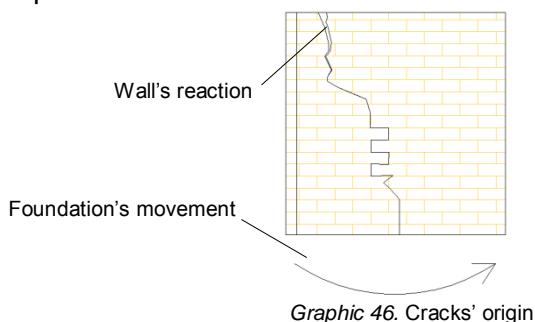

Graphic 46. Cracks' origin



Picture 143. Plaster test for the crack's state check

### 3. VERTICAL CRACKS UNDER THE WINDOW



Picture 144. Vertical cracks under the window

**Location:** under the *Big Room's* window on the west side, in the second floor of the Brotherhood House.

**Pathology definition:** as it can be observed in the pictures, the cracks just appear under the window in vertical sense. Therefore, as there are no more cracks in the whole window outline, it can be suspected that the vertical cracks are caused by the dampness, which may have filtered by the windowsill.

It's a consequence of a wrongly weatherization and there have been producing water rain filtrations, which have produce cleanings in the vertical surface under the window.



Picture 145. Exterior window sight



Picture 146. Interior window sight



#### 4. WOOD BEAMS: REDUCTION OF FLEXURAL STRENGTH AND INFLORESCENCES.



Picture 147. Wood beam strutted

**Location:** floor structure located over the stairs to access to the first floor from the ground floor.

**Pathology definition:** as it can be seen in the pictures, the wood joists have experienced a clear reduction of flexural strength, because after being repaired, it's still necessary to strut one of them. This may be caused because the wood beams section wasn't the appropriate one for supporting the weigh over them. Besides, they have suffered a weakness after the dampness filtration, because over the wood floor structure is placed a shed roof. There would be recommendable to check the woods heads as well, in order to study their state.

On the other hand, the structural framework suffers some inflorescences, which are white and dry dusts resultant from the precipitation and posterior crystallization of the soluble salts in the water. They settle down in the surfaces that have been exposed to dampness when they are dry and the liquid evaporates.

This pathology may cause in long term the structural framework collapse if the beams don't get fixed.



Picture 148. Wood beams fixed into the brick wall

## 5. INFILTRATION EFFLORESCENCES AND DAMPNESS IMPERFECTIONS



Picture 149. Skylight over the first floor corridors

**Location:** the skylight is placed over the corridor in the first floor of the Brotherhood House.

**Pathology definition:** the filtration dampness usually is produced as a consequence of weatherization absence or with deficient weatherization areas, which allow the water filtration. Therefore, the filtration dampness has been produced throughout the skylight.

One possible cause of this filtration may be wrongly execution of the meeting of the skylight with the roof weatherization. The rain water goes through it and produces the interior side stains, as well as the flaws.

On the other hand, there have been produced cracks along the skyline perimeter, marking the meeting with the parapet.

## 6. FILTRATION DAMPNESS



Picture 150. Filtration dampness

**Location:** room whose access is placed on the lateral right door of the main façade.

**Pathology definition:** as it can be seen in the pictures, the room has severe problems because of the filtration dampness. This filtration has been produced through the passable plain roof located over the room. In order to determinate the causes if the filtration, it would be necessary to make a roof study.

On the other hand, there also exists capillarity dampness, which ascends from the land through the walls by its porous materials and rise to certain height. In this case, the height is increased because of the room's perimeter skirting board, that doesn't let the walls transpire.

At long term, the dampness may cause healthiness and durability problems (painting bubbles, loosening of mortar fillings and even structural damages) in the constructive elements.



Picture 151. Filtration dampness



Picture 152. Passable plain roof where the filtration is produced

## 7. CLEANINGS



Picture 153. Vertical surface cleanings

**Location:** vertical surface of the *Former Meeting Room*, in the second floor of the Hermitage House. .

**Pathology definition:** the cleanings are a consequence of the direct action of the rain water on the vertical surfaces. The overflows over them produce an erosive cleaning action in the brick wall eliminating and sweeping along materials and superficial deposits of dirt. In this case, as the rain water has sweep along dirt, the coloration of the affected surface is made in a darker tone.

On the other hand, in the inferior part of the surface, there can also be appreciated several painting flaws, probably due to the dampness which it has been submitted.

Although apparently this lesion may not seem very prejudicial, sometimes, when the water speed is very slow it can be associated to concretions or calcareous deposits.

## 8. FISSURES AND CRACKS



Picture 154. Fissures and cracks in the wattle ceiling

**Location:** in the ceiling of the *Room 1*, in the first floor of the Brotherhood House.

**Pathology definition:** as it can be appreciated in the pictures, the wattle ceiling presents some fissures and cracks in the areas where the Wood beams are placed. These cracks are probably a consequence of the dampness filtration present in the entire building, which has been ended up making weak the floor structure.

As long term consequence, if the wattle ceiling isn't replaced it may collapse, due to the material characteristics.

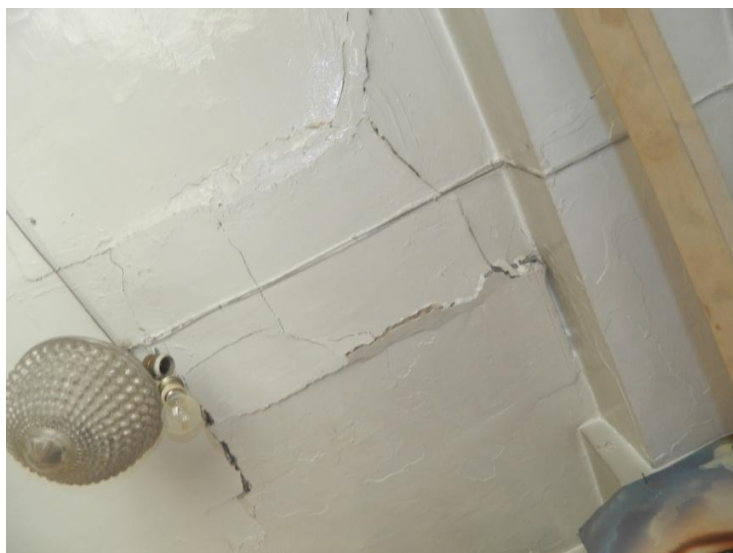

Picture 155. The ceiling about to collapse

## 9. INAPPROPRIATE ELEMENTS AND MUTILATIONS



Picture 156. Inappropriate elements and mutilations

**Location:** room whose access is placed on the lateral right door of the main façade.

**Pathology definition:** the aesthetic character alteration is produced by the inappropriate element such as the wiring electric system centered in the interior of the room.

On the other hand, there're also appreciated mutilations in the brick wall and the ceiling, where a violent pull up of the material has been produced. These wrongful mutilations are a cause of the omission of the modern techniques to make exploration test, such as the boroscope.

In the case of the brick wall, the mutilation has also provoked a loosening of the covering material around the hole.







DAMAGE DOSSIER		SECOND FLOOR																		
		Stairs			Hall			Room 3			Bell Founder Archieve			Former Meeting Room			Big Room			
		Vertical Surface	Ceiling	Flooring	Vertical Surface	Ceiling	Flooring	Vertical Surface	Ceiling	Flooring	Vertical Surface	Ceiling	Flooring	Vertical Surface	Ceiling	Flooring	Vertical Surface	Ceiling	Flooring	Closet
Contaminating Agents	Dirt			X			X			X			X			X				X
	Soiling																			
	Darkening																			
	Dampness	X	X	X	X	X	X	X	X	X				X	X	X	X	X	X	X
Physical-Chemical Actions	Rotting																			
	Fisures																			
	Cracks								X					X						
	Loosening of material																			
	Flaws						X	X				X	X	X						
	Fluting																			
	Cleanings										X									
	Empty joints																			
	Loosening of resistance																			
	Inflorescences																			
	Biotic Actions	Mould																		
Vegetation																				
Excrements																				
Insects																				
Moss																				
Human Intervention	Inappropriate interventions																			
	Inappropriate acts or elements																			

1. The green boxes mean that these lesions are not present in the Brotherhood House.

## 7. INTERVENTION PROPOSAL



## 7. INTERVENTION PROPOSAL

### INTERVENTION CRITERION

The intervention criterion in this refurbishing project of the Brotherhood rooms at Santa Lucia's Hermitage has been declared conservative as far as possible. It's come to this conclusion after considering the long history the building has, and how important it's for the members of the Brotherhood.

The elements that must be replaced will be changed by others with the same nature or a similar appearance, as well as the finishes will follow the remaining aesthetic. This is to say, the intention is to act in the Brotherhood House without modifying its disposition, so it will have the same appearance as in its beginnings but with constructive improvements.

### CLASSIFICATION OF DAMAGES

The classification of damages has been done regarding on its gravity and the consequences and development they might have. This way, the primary interventions are the most serious lesions, as the structural ones, while the less important lesions are left in the end, as the aesthetic ones. Therefore, the damage classification regarding their importance will be as follows:

1. VERY SERIOUS	2. SERIOUS	3. SLIGHT
Beams: Loosening of resistance	Bended lintel	Inflorescences
Cracks: foundation movements	Filtration dampness	Loosening of material
		Fissures
		Cracks
		Empty joints
		Inappropriate elements
		Mutilations
		Cleanings

Table 1. Classification of damages

This classification is made in this order considering that the timber works are the most urgent lesion, because they are appreciably damaged. The bended lintel is another lesion with future structural damages, so it's important to repair it before the situation gets worse. Right after, it would be convenient to solve the damp problems of the Hermitage, because they could also affect the structure at a long term.

The following lesions to solve because their lower structural commitment, are the cracks, the inappropriate elements, the mutilations and the cleanings. In the case of the vertical crack in the brick wall, it's remarkable the fact than the crack is not active and doesn't have serious consequences. If the crack were detected as active, the lesion would be more urgent and it would be solved firstly.

## INTERVENTION OF DAMAGES

### 1. EXCEEDED DEFLECTION AND PEELING OFF IN A LINTEL

**Intervention proposal:** the intervention to make in this lesion is the substitution of the metallic lintel and the wood beam by a new metallic lintel, and afterwards to repair the covering material peeled off.

**Intervention:** first of all, a complete shoring up of the affected area by the transmitted loads must be done. In addition, the window hole has to be enclosed in order to provide it with more rigidity and to avoid the displacements and twists.

Once the wall is correctly shoring up, it will be made a material perforation around the lintel and the wood beam, as well as in their supporting areas. After the extraction of both elements, the area will be cleaned from the remaining little rests of materials.

Previously to the positioning of the new metallic lintel, it will be made a filling of mortar in the perforated brick wall area. The new lintel will be based over this mortar filling. As the wall's thickness that doesn't rest over the brick solid brick layer, (about 30 cm.) allows it, the metallic lintel will be made by two metallic profiles completely connected with fastening profiles.

Right after, it will be opened a hollow in the wall to place the first metallic profile, welding it by its inferior side to the metallic fastener. The profile is wedged every 50 cm. approximately by steal wedges, filling it with an expansive mortar in order to secure the perfect brick wall support over the metallic profiles. The other metallic profile will be placed the faster possible and following the same process as the first one.

Finally, when the mortar has been harden enough, it will be proceed to retire the support and strut in phases, in order to make everything to settle homogeneously. Right after, the filled with mortar area will be covered by the same material as it's in the entire room.

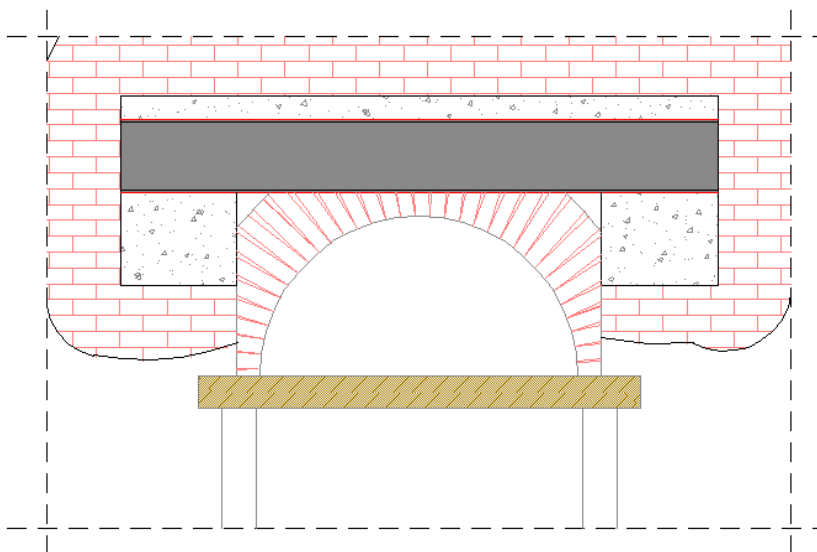

Graphic 47. Frontal view of the new lintel

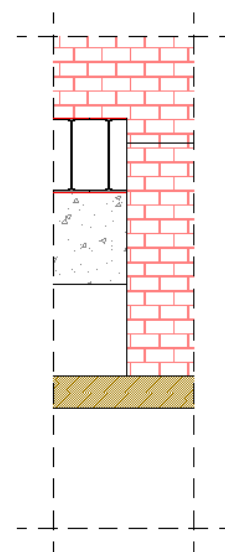

Graphic 48. New lintel's section

## 2. VERTICAL CRACKS AND EMPTY JOINTS

**Intervention proposal:** The testers that were positioned have proved no expansion of the crack width over time..Therefore it can be concluded that the soil and foundations are properly settled down, and they are not affecting the structural elements.

So the intervention will be reduced to a cracks sealing task, filling them by applying the same natural mortars as the existing ones (rigid sealing) by gravity with the *Jet Grouting* method

**Intervention:** the affected areas in the entire thickness of the crack will be cleaned by applying compress air and pressuring water. Previously, there will be made the corresponding X-lightning diffraction essays, as well as other laboratory essays that will determine the existent mortar and paste's physical and chemical properties. Finally, the surface will be painted using the same color tones as the rest of the corridor has.

This solution is relatively economical and efficiency, besides of being a quick-executed solution, which requires a qualified workforce.

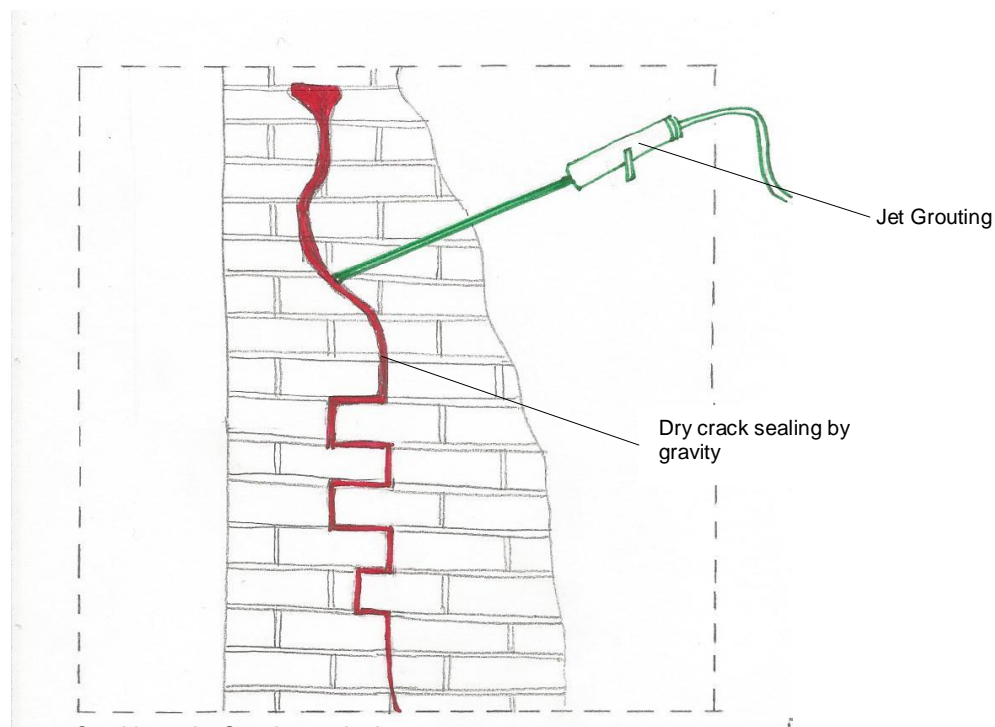

Graphic 49. Jet Grouting method

### 3. VERTICAL CRACKS UNDER THE WINDOW

**Intervention proposal:** this pathology would be solved by adding a wash and weatherizing the windowsill in order to eliminate every water filtration possible. Afterwards, the cracks produced under the window will be sealed.

**Intervention:** first of all, the damaged material under the window will be removed by punching it. Right after, there will be made two holes in the wall jambs in order to install the wash. The regulation and sloping formation mortar will be spilled to the outside by a damp-proof mortar. Then, the wash is put by adhering it with glue cement, and finally, the joints will be sealed by polyurethane filler.

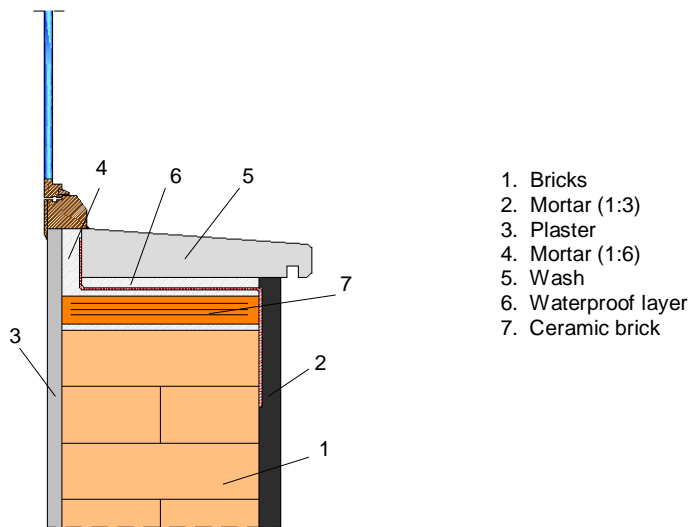

Graphic 50. The window with the wash

On the other hand, the cracks produced in the interior under the window will be sealed by applying plasters with the same characteristics as the remaining ones. Previously it would be recommended to clean up the affected areas, as well as there will be made the corresponding X-lightning diffraction essays, as well as other laboratory essays that will determine the existent mortar and paste's physical and chemical properties. Finally, the surface will be painted using the same color tones as the rest of the wall has.

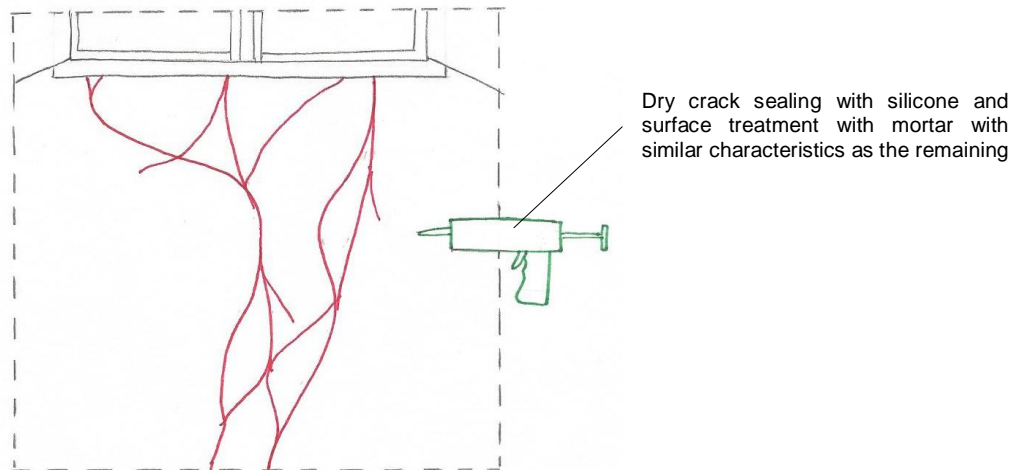

Graphic 51. Crack sealing

#### 4. FILTRATION DAMPNESS AND FLAWS

**Intervention proposal:** after exploring the areas when the skylight infiltrates the rain water, it will be proceed to its weatherization in order to avoid future dampness infiltration and rain water. After that, the joints and flaw produced will be sealed.

**Intervention:** in order to stop the damp infiltration throughout the skylight, it will be necessary to remove it and change it for another one. It will be inevitable to remove also the corresponding part of the roof necessary to install the skylight, and due to this fact it will have to be replaced when this installation is done. It is important to weatherize the skylight correctly so as to avoid future infiltrations. Only by applying this method where the rain water infiltrates, the problem might be solved. .

On the other hand, to solve the damp stains, it will be enough to apply a painting layer. Previously, the affected area will be cleaned in order to become detached from the loose and weak fragments. This way, the imperfection will increase, but the limits will be steady.

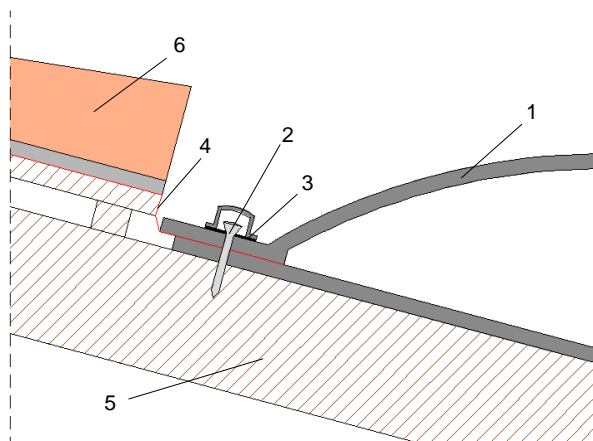

Graphic 52. A-A' Section: new skylight fixed into the wood joist

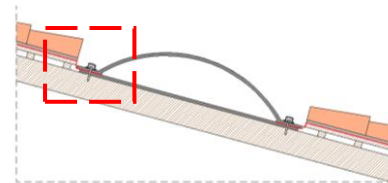

Graphic 53. A-A' Section

1. Skylight
2. Screw
3. Neoprene (joint sealing)
4. Waterproof layer
5. Wood joist
6. Tile

As for the remaining cracks and the flaws concern, before repairing them it will be necessary to clean the area in order to get rid of the weak and lose fragments. This way, the imperfection will increase, but the limits will be steady. There's also necessary to clean the entire surface, because the dirt would difficult the reparation material grip.

Afterwards, the plaster will be directly applied with a trowel or a palette. When the new plaster layer is dried, it will proceed to the sand down of the rest of the vertical surface. Finally, this surface will be painted applying the same tone as the remaining painting.



## 5. FILTRATION DAMPNES

**Intervention proposal:** the intervention to make in this case consists on weatherize again the practicable flat roof placed over the room.

**Intervention:** in order to weatherize the practicable flat roof, it will be compulsory to remove the actual pavement and its preceding layers. In addition, the vertical surfaces will be punched to check every singular joints where there's possible for the damp to infiltrate. After the identification of these singular joints, the new practicable flat roof will be placed again by weatherizing it appropriately so as the damp won't infiltrate in the future.

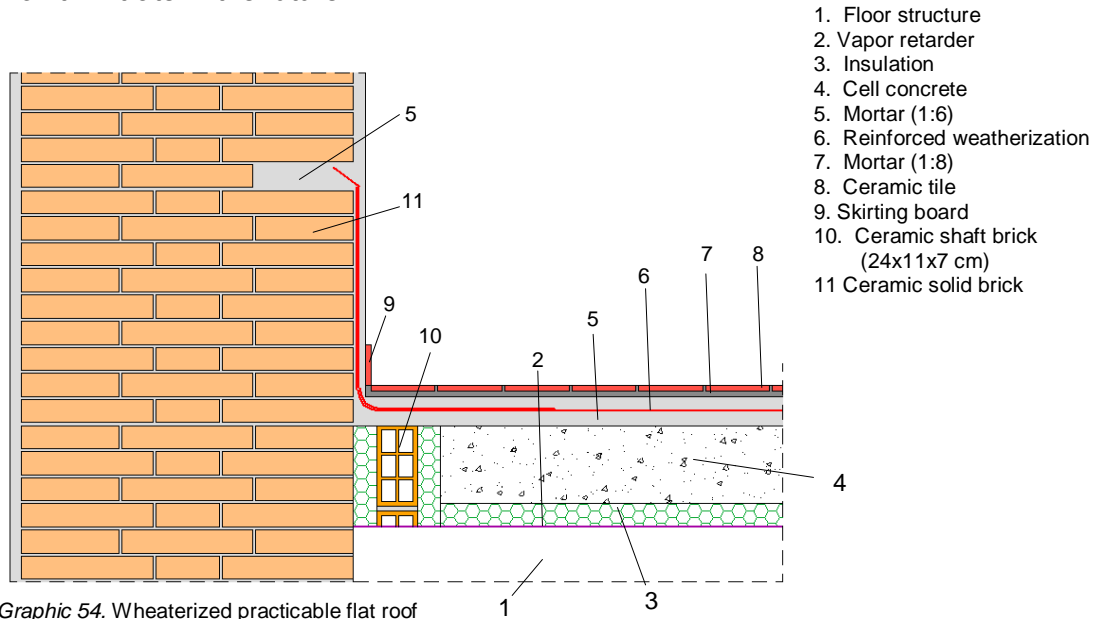

Graphic 54. Wheaterized practicable flat roof

As far as the capillarity dampness concerns, it will be installed the use of electronic devices which emit an electric sign that nullifies the wall's electrostatic field by reversing its polarity and preventing the capillarity ascendance. This system is rapid and simple, and at the same time has effect in other surfaces as the pavements.

Once the dampness is removed, the affected areas will be cleaned up and repaired by using the same mortars as the remaining and breathable paintings.

## 6. CLEANINGS

**Intervention:** this pathology has a simple solution, by cleaning the affected surface with a sponge and non-ionized water. After leaving a dry time, the painting will be applied again in the vertical surface.

As for the flaws, first of all the area will be cleaned in order to become detached from the loose and weak fragments. This way, the imperfection will increase, but the limits will be steady. There's also necessary to clean the entire surface, because the dirt would difficult the reparation material grip.

Afterwards, the plaster will be directly applied with a trowel or a palette. When the new plaster layer is dried, it will proceed to the sand down of the rest of the vertical surface. Finally, this surface will be painted applying the same tone as the remaining painting.

## 7. INAPPROPRIATE ELEMENTS AND MUTILATIONS

**Intervention proposal:** the intervention to make is the filling of the opened hole, with the same kind of materials as the wall has.

**Intervention:** first of all, the covering material around the hole will be punched, as well as the damaged pieces will be removed. Afterwards, the hole will be filled with solid bricks with the same dimensions as the remaining in the wall.

Right after, the wall will be plastered over the new bricks, and finally it will be painted in the same way as the rest of the vertical surface is.

As for the light cables hanging in the center of the room, they can be fixed to the vertical surfaces and the ceiling in order to avoid the visual disorder they produce.

**PARTICULAR INTERVENTIONS. INTERVENTION PROJECT**

**1. TIMBER BEAMS: REDUCTION OF FLEXURAL STRENGTH AND INFLORESCENCES**



Picture 157 and 158. Different views from the floor structure.

The first element to be fixed is the floor structure which covers de Access to the first floor. This element is composed by three wood beams fixed into the solid brick wall. After checking with a punch the drive length in order to verify the wood's state, the conclusion to arrive is the following one: the beams have lost a great part of their structural strength and show some rotting signs in their heads-ends.

Therefore, the intervention proposal will be the substitution of the strutted beam for another new one, and the change of the heads of the other two beams. Afterwards, the entire structure will get the inflorescences cleaned. The order of the intervention will be the as follows:

**1. Shoring up the beams for their substitution**

First of all, the floor below ought to be strutted in the working area. The replacement beam will be a laminate wood beam with the dimensions 250x20x10 cm. Once this new beam is in the working place, the supporting area of the changing beam will have to be strutted as well, by putting a shoring up board in the ceiling. The changing beam will have also three supports: one in the center and two in the opposite sides.

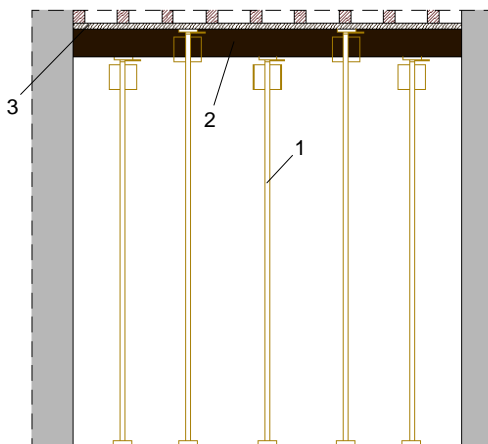

Graphic 55. Frontal vision of the strutted system.

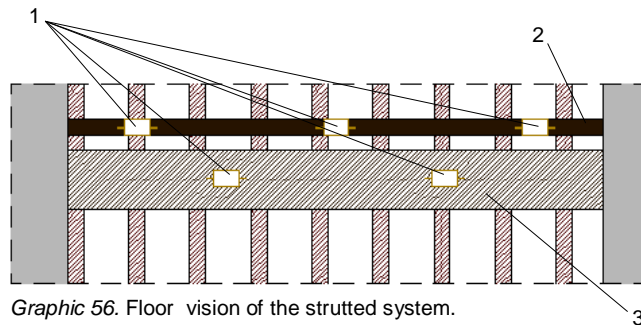

Graphic 56. Floor vision of the strutted system.

- 1. Support
- 2. Timber beam
- 3. Board

When the shoring up system is checked and considered secure, next will be to proceed with the beam's cut in its central stretch with a circular saw. Right after, the two remaining pieces of beam will be extracted one after the other one.

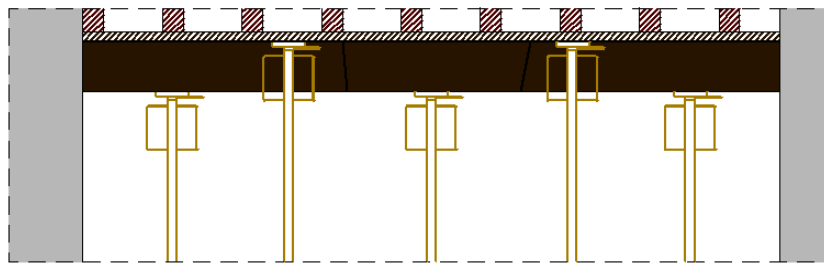

Graphic 57. 1. Beam cut in the middle part

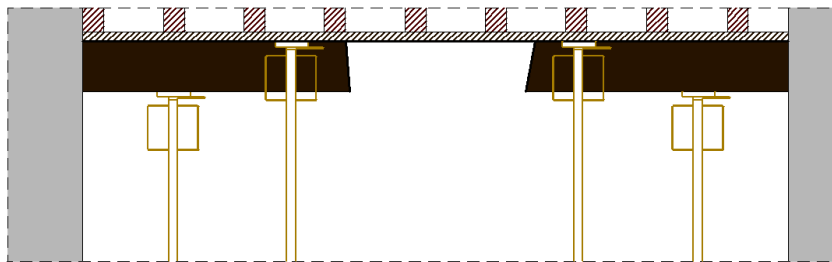

Graphic 58. 2. Retirement of the beam's cut central

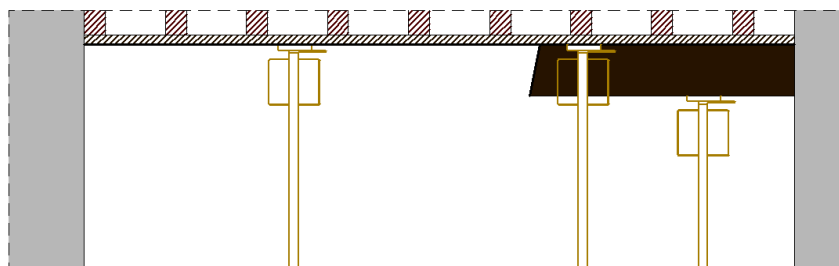

Graphic 59. 3. Retirement of the remaining left side

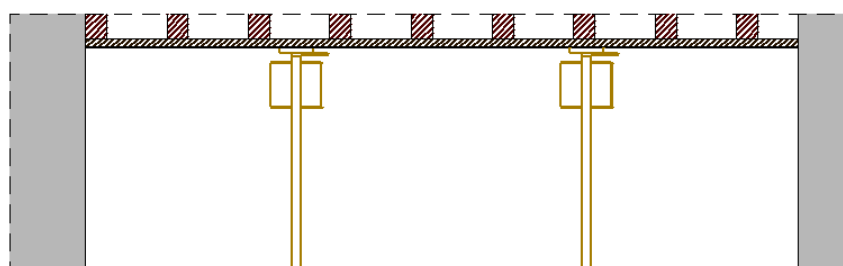

Graphic 60. 4. Retirement of the remaining right side

Once the beam is completely extracted, the fixing holes will be cleaned, so as the new beam it's installed in the best possible conditions.

For the wood beam's substitution it will have been necessary to take measurements from the walls and then add the correspondent embedding. This embedding in a wood beam oscillates between ten and fifteen cm. in each side.

The length of the two embeddings will be introduced in the hole to check if it's possible to slide the beam to the opposite side the needed length to divide the embedding in the two holes.

Afterwards, one of the sides of the new wood beam is introduced in one of the wall holes, while the opposite side is held by two workers. These workers will pull up the beam carefully until it arrives to its place. Thanks to the free movement spaces of the walls the beam will be installed easily.

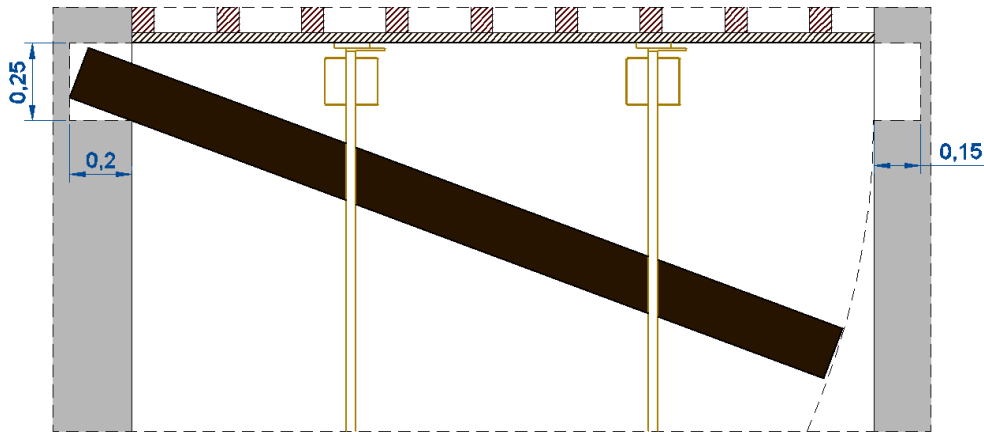

Graphic 61. New wood beam collocation: the left side is put in the gap and the other one is being rose by workers

When the beam is in its place, there will be installed two supports on the opposite sides in order to elevate it to the floor structure. Afterwards, the new beam will be wedged and filled with mortar and mud or stoned wedges, making sure everything is well solid and without pores or space for movements.

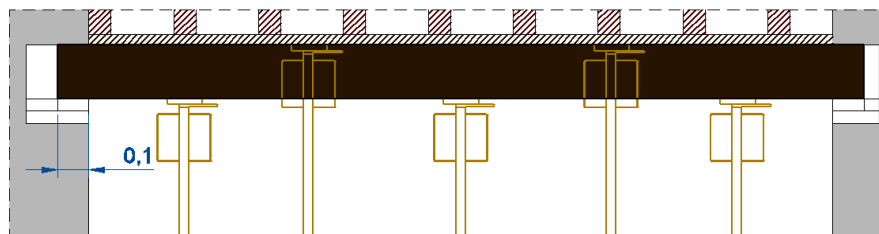

Graphic 62. Final position of the new beam

In order to improve the adhesion with the filling, it's recommendable to add little metallic bars embedded in the head of the beam, as it's explained in the graphic below.

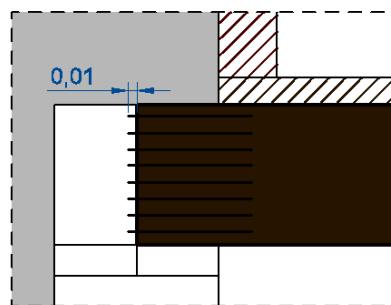

Graphic 63. Metallic bars standing 1 cm out of the beam

**1. The rotten heads substitution** of the other two Wood beams. This process will comprise the following phases:

First of all, the two opposite sides of the beam will have to be strutted, having in mind they are placed over the stairs. The next step will be the saw of the rotten part. Previously, it will have necessary to perforate the wall enough so it can be possible to work comfortably.

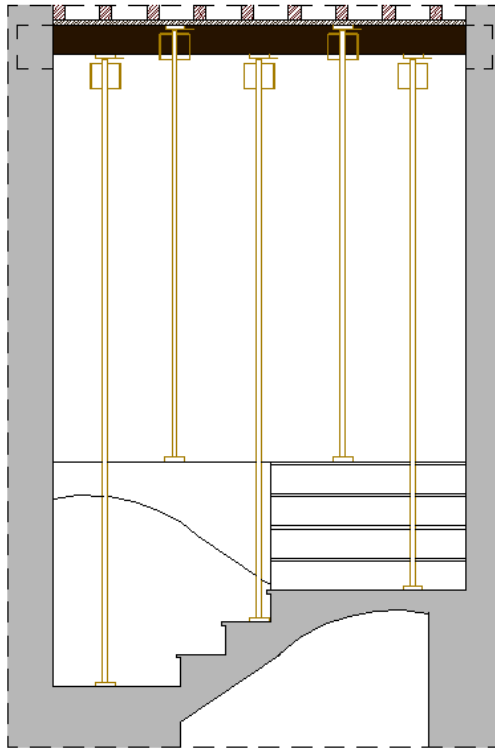

Graphic 64. Strutted beam in the stairs

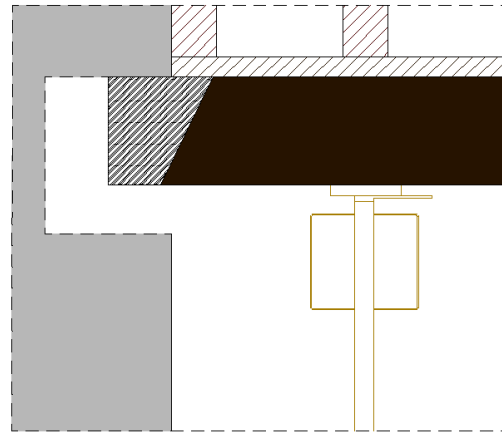

Graphic 65. Rotten beam head to be cut

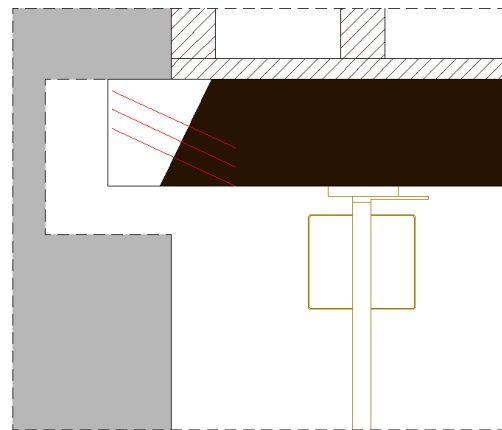

Graphic 66. Fiberglass ribs with epoxy resins

Right after, in the cut side are introduces some fiberglass ribs with epoxy resins, forming from 25° to 30° with the horizontal plan.

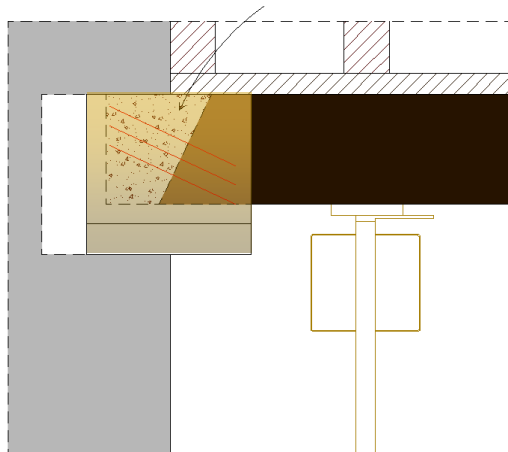

Graphic 67. Spilled of the epoxy resins

The following step is the elaboration of a formwork in the beam in order to be able to spill lately the epoxy resins with silica sand load, which will proportion the new beam head with dark brown color, simulating the wood.

This same process will be repeated in the opposite beam head side. When the resins would have hardened, the formwork will be retired and the wall holes will be repaired, with bricks with the same nature as the remaining ones. The new beam will be wedged and filled with mortar and mud or stoned wedges, making sure everything is well solid and without pores or space for movements.

The same process of heads substitution will be repeated in the other beam.

## **2. Inflorescences elimination**

Finally, after intervening in the three wood beams, the inflorescences elimination in the floor structure surface will be made.

Right after checking the inflorescences are dry, the easiest elimination treatment consists on dissolving the crystals with pressuring water and moving them away with a natural bristles brush. This kind of cleaning must be done in a warm day in order to evaporate the water and dry the surface. On the contrary, the salts will dissolve again in the interior of this structure.

If the crystals aren't dissolved with the water, it's needed a hydrochloric acid cleaner, which must be applied with pressure. When the salts are crystallized and harden it's necessary to resort to a metallic tooth brush or electric brushes.

## 2. FISSURES AND CRACKS IN THE GYPSUM CEILING



Picture 159. Craks in the gypsum ceiling

The second element to be fixed is the gypsum ceiling of the *Room 1*, in the first floor of the Brotherhood House. In this case, the solution to apply is the demolition of the ceiling and the subsequent installation of a *pladur* (a gypsum board) false ceiling fixed on the roof. The intervention sequence will be as follows:

Previously to the false ceiling demolition, the ceiling lamp will be removed. Afterwards, the ceiling will be punched until it's totally removed as well. The, the vertical surface will be cleaned up and the rubbish will be removed away in order to be able to continue the works. Once the wattle ceiling is been removed, the new *pladur* ceiling will be installed.

First of all, after having taken the level points correctly with a marking tape, the level marking lines are taken along the vertical surface. These lines will indicate the angular perimeter profiles plan. There will be also marked the situation lines of the master longitudinal profiles as well. It must have been minded that the first lateral lines couldn't be separated a longer distance that the module established between them.

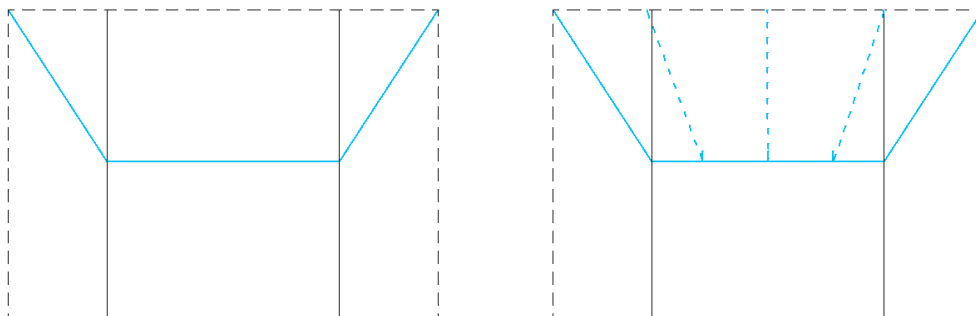

Graphics 68 and 69. Level marking lines in the vertical surface



The next step will be the collocation of the angular profiles, by fixing it to the brick walls. The distance between these fixings won't be longer than 60 cm.

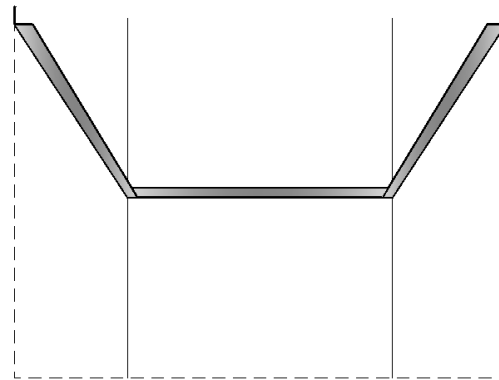

Graphic 70. Collocation of the angular profiles

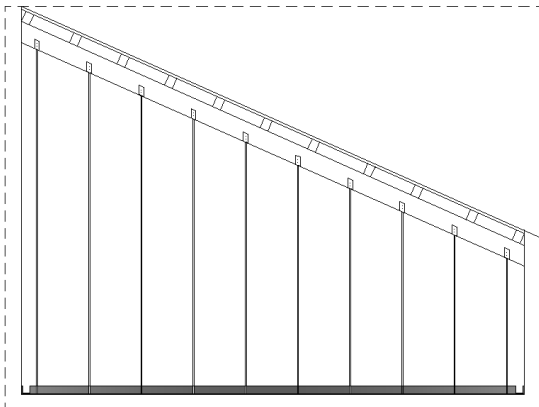

Graphic 71. Ribs and forks fixed into the wood beam

Right after, the ribs and forks will be fixed in the beam roof structure starting on the corners of the working area, making a first leveling out of the surface. It's important to keep in mind not to separate the ribs from the wall a distance longer than 1/3 the established module separation.

The last structure collocation step will be the longitudinal master profiles installation, which will fit in the forks. The longitudinal master profiles will support on the perimeter angular profiles (not to screw on them) and staying separated from the walls about 10 cm.

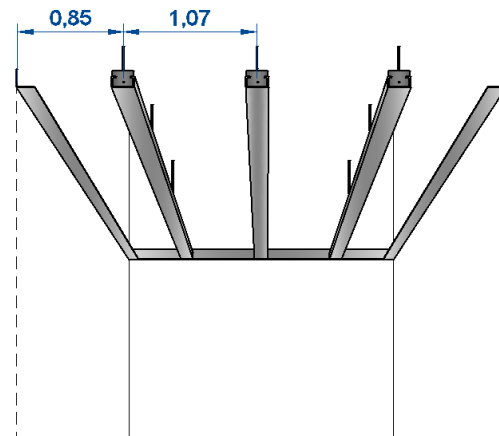

Graphic 72. Longitudinal master profiles installation

Once the structure is collocated, it will proceed to screw the *pladur* sheets on the longitudinal master profiles, orthogonally to them. The transversal sheet joints must be countered between themselves at least 40 cm.

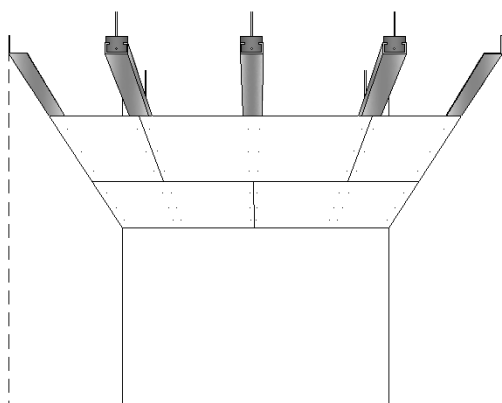

Graphic 73. Pladur sheets collocation

Finally, the joint treatment will be done following these phases:

1. Seated and straightened if the tape with a joint paste. Then a time to dry.
2. Previous phase covering with a more thickness area. Then a time to dry.
3. A minimum of two more layers with a time to dry between them.
4. Sand down the surface and painting.

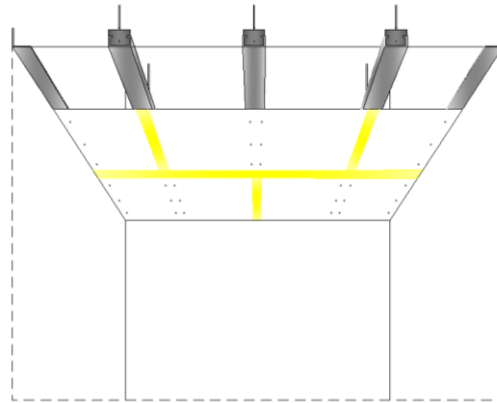

Graphic 74. Joint treatment

## TIME CHART

---

The following list contains all the damages existing in the Brotherhood Rooms, and the connection between every lesion with the rest of them:

1. Cracks due to foundation movements. First intervention.
2. Filtration dampness. After lesion 1 and before lesions 3 and 4.
3. Loosening of resistance of the beams. After lesion 2 and at the same time as lesion 4.
4. Bended lintel. After lesion 2 and at the same time as lesion 3.
5. Inflorescences. After lesion 3 and before lesions 6-10.
6. Cleanings. After lesions 3 and 4 and before lesions 11 and 12.
7. Loosening of material. After lesions 3 and 4 and before lesions 11 and 12.
8. Cracks. After lesions 3 and 4 and before lesions 11 and 12.
9. Fissures. After lesions 3 and 4 and before lesions 11 and 12.
10. Empty joints. After lesions 3 and 4 and before lesions 11 and 12.
11. Inappropriate elements. After lesions 6-10 and at the same time as lesion 12.
12. Mutilations. After lesions 6-10 and at the same time as lesion 11.





## CONCLUSIÓN

En cuanto al estado del edificio, la Ermita de Santa Lucía data del año 1400, por lo que a lo largo de su extensa vida ha sido intervenido en numerosas ocasiones. Recientemente se reformaron las cuatro fachadas, así como la zona de alrededor. Esto permitió solucionar, o no agravar, los graves problemas de humedades que sufre el edificio. Sin embargo, las estancias de la Casa de la Cofradía, situada en el interior de la Ermita, necesitan ser intervenidas.

Tras inspecciones visuales, las lesiones producidas en el edificio fueron identificadas y clasificadas. En un principio, se temió por una lesión en particular que podría tener graves consecuencias estructurales. Esta lesión es la grieta producida en el pasillo, que va reduciendo su sección conforme desciende. La grieta es consecuencia del movimiento de la cimentación, y si este movimiento no había terminado, sería necesario reforzar los cimientos. Sin embargo, tras colocar testigos, se comprobó que la grieta no estaba viva, por lo que se llegó a la conclusión de que los cimientos ya se habían asentado y no iban a producir más movimientos en la estructura. Por ello, esta lesión pasó a tener menos importancia estructuralmente.

Por otra parte, la otra lesión más grave que se puede encontrar en la Casa de la Cofradía es la pérdida de resistencia de las viguetas de un forjado. En un principio, también se temió que esta pérdida de resistencia fuera obra de quirópteros, pero tras inspecciones realizadas introduciendo en las mismas, se desechó esa posibilidad y se llegó a la conclusión de que el debilitamiento de las viguetas se debía al pudrimiento ocasionado por las filtraciones de humedad.

En cuanto a las demás lesiones, es destacable que ninguna tiene una seria importancia ya que la mayoría son causa de la filtración de humedad. Sin embargo, sería recomendable solucionarlas cuanto antes, porque pueden llegar a derivar en patologías más graves si se les ignora.

En resumen, las lesiones que se encuentran en las estancias de la Casa de la Cofradía de Santa Lucía no han sido identificadas como muy graves, tras inspecciones visuales y la utilización de técnicas como el punzón o testigos. Si bien, es recomendable que se solucionen lo antes posible como método de prevención de problemas más graves.

Realizar este Proyecto Final de Grado me ha permitido en primer lugar profundizar en la materia de intervención en edificación. La carrera de Ingeniería de Edificación abarca numerosas asignaturas, dentro de las cuales predomina la *construcción*. Sin embargo, desde mi punto de vista, la intervención en edificios es un tema muy interesante y con futuro. Por esta razón decidí escoger esta temática para trabajar en el Proyecto.

Por otra parte, la decisión de realizarlo en inglés, que fue tomada en el último momento, me ha permitido ampliar los conocimientos en este idioma. Asimilar todo el vocabulario técnico ha supuesto un esfuerzo extra pero que, en mi opinión, ha valido la pena. Lo considero una experiencia muy enriquecedora que volvería a repetir.

También es importante destacar la manera en que me han guiado y ayudado mis tutores, D. Enrique David y D. Jaime Llinares, a lo largo de todo el proceso de elaboración del Proyecto. Asimismo, también me ha facilitado mucho el trabajo la amabilidad y disposición del Dr. Francesc Llop i Bayo, Clavario Presidente de la Cofradía.

Por todo ello, este trabajo ha sido una inspiración para continuar formándome en intervención de patrimonio construido y buscar estudios de posgrado en esta materia, que me permitan especializarme en ella y dirigir mi futuro profesional en esa dirección.

De la misma forma, mi intención es seguir estudiando inglés y obtener títulos oficiales, e incluso empezar a estudiar otros idiomas, ya que lo considero muy útil para mi futuro profesional. Ello me permitiría ampliar los horizontes en cuanto a la búsqueda de un trabajo, y al mismo tiempo que disfruto aprendiendo idiomas y culturas diferentes

## CONCLUSION

As for the building's state, Santa Lucia's Hermitage dates from the year 1400, and that's the reason why along its extensive life it has been intervened several times. Recently the four façades were intervened, as well as the surrounding area. This refurbishment supposed the solution (or non aggravation) of the great dampness problems present in the Hermitage. Nevertheless, the rooms of the Brotherhood House, placed in the interior of the Hermitage, need to be intervened.

After some visual inspections, the lesions produced in the building were identified and classified. At first, there was a fear about one particular lesion which might had been serious structural consequences. This lesion is the cracks produced in the *Corridor 1*, which diminishes its section as it descends diagonally. The crack is a consequence of a movement in the foundations, and if this movement had been alive, it would have been necessary to reinforce them. However, after the collocation of testers, it was confirmed that the cracks weren't alive, so it was concluded that the foundations had stabilized and they weren't going to produce more structure movements. For this, the lesion passed to be less structurally important.

On the other hand, the other serious lesion that can be appreciated in the Brotherhood House is the loosening of resistance of the three joists present in the floor structure that cover the stairs. At the beginnings, there was also a fear in case this loosening of resistance was a consequence of an insect attack. Nevertheless, this possibility was turned down because the rotting came by the dampness filtration.

As for the rest of lesions regard, it's remarkable that none of them has a serious importance, as the great part of them is consequence of a dampness filtration. Despite it, it would be recommendable to solve them as soon as possible, because these lesions could originate more serious problems if they are ignored.

In short, the lesions found in the rooms of the Brotherhood House are not identified as very serious, after examine them with visual inspections and techniques

such as the punch or the testers. Although, is advisable to have them solved in order to prevent more serious lesions.

In personal matters, making this Final Bachelor Project has let me to study in depth the building intervention subject. Building engineer career includes several subjects, within predominates *Construction*. However, from my point of view, building intervention is a very interesting point and with future. That's the reason why I decided to choose this thematic to work on the Bachelor Project.

On the other hand, the decision of making it in English, which was taken at last minute, has let me improve my knowledge in the language. To assimilate all the technical language has supposed an extra effort which, in my opinion, it has been worth. I consider it a very rewarding experience that I would repeat.

It is also important to remark the way I have been guided and helped by my tutors, Mr. Enrique David Llácer and Mr. Jaime Llinares Millán along the elaboration process of the Project. Additionally, the kindness and disposition of Dr. Francesc Llop i Bayo, President of Santa Lucia's Brotherhood, has facilitated me the work quite a lot.

For all these reasons, this Project has been an inspiration to continue forming myself in *Heritage Intervention* and the search of post-graduate studies in this subject, which allow me its specialization so I could lead my professional future in this direction.

In the same way, mi intention is to continue studying English language and get official titles, and even star to study other languages, because I consider it absolutely useful for my professional future. That would let me to broad my horizons regarding the job searching, and at the same time I enjoy learning languages and different cultures.





## **ANNEX: handmade sketches**



# GROUND FLOOR

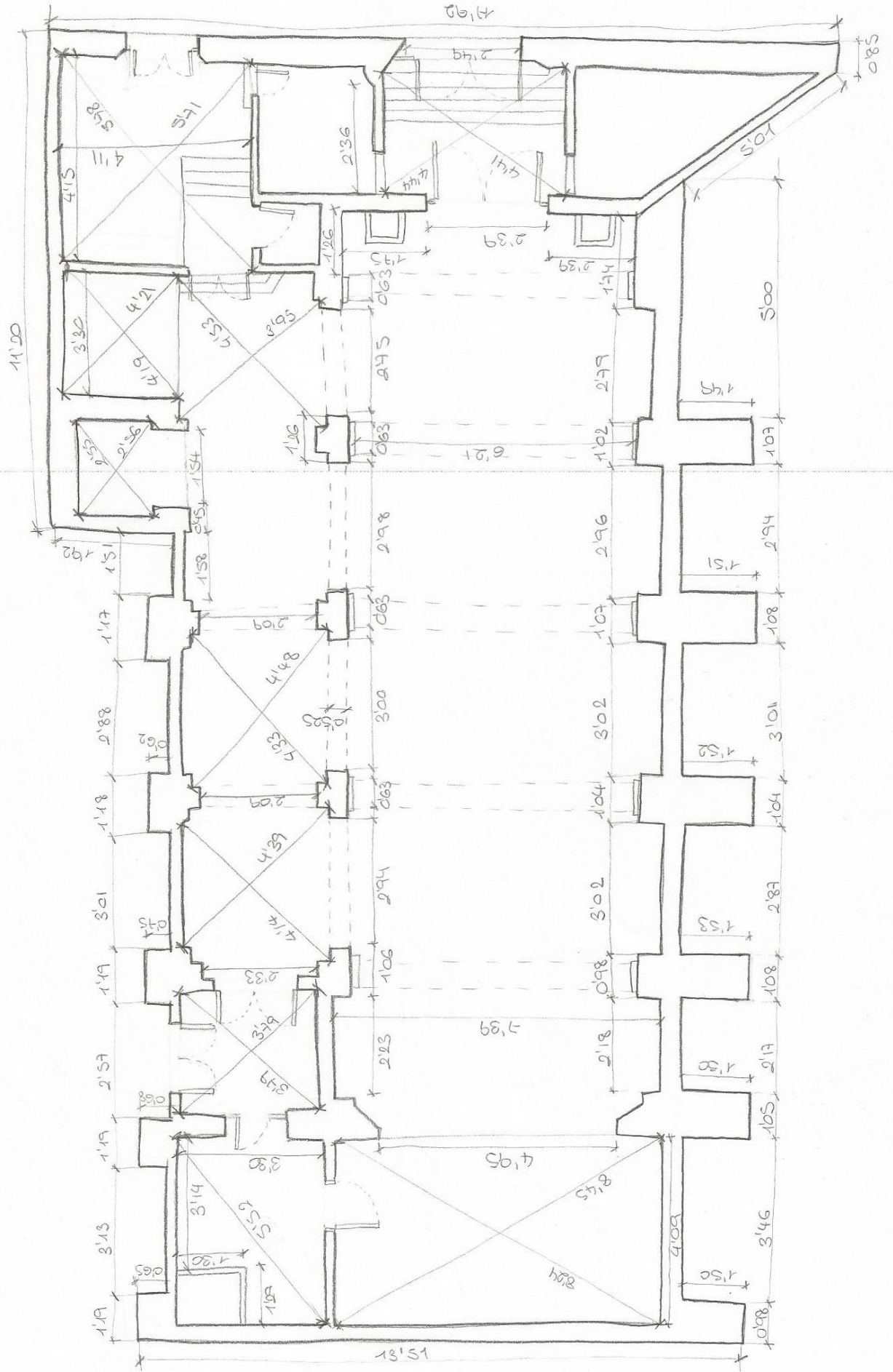



# SECOND FLOOR

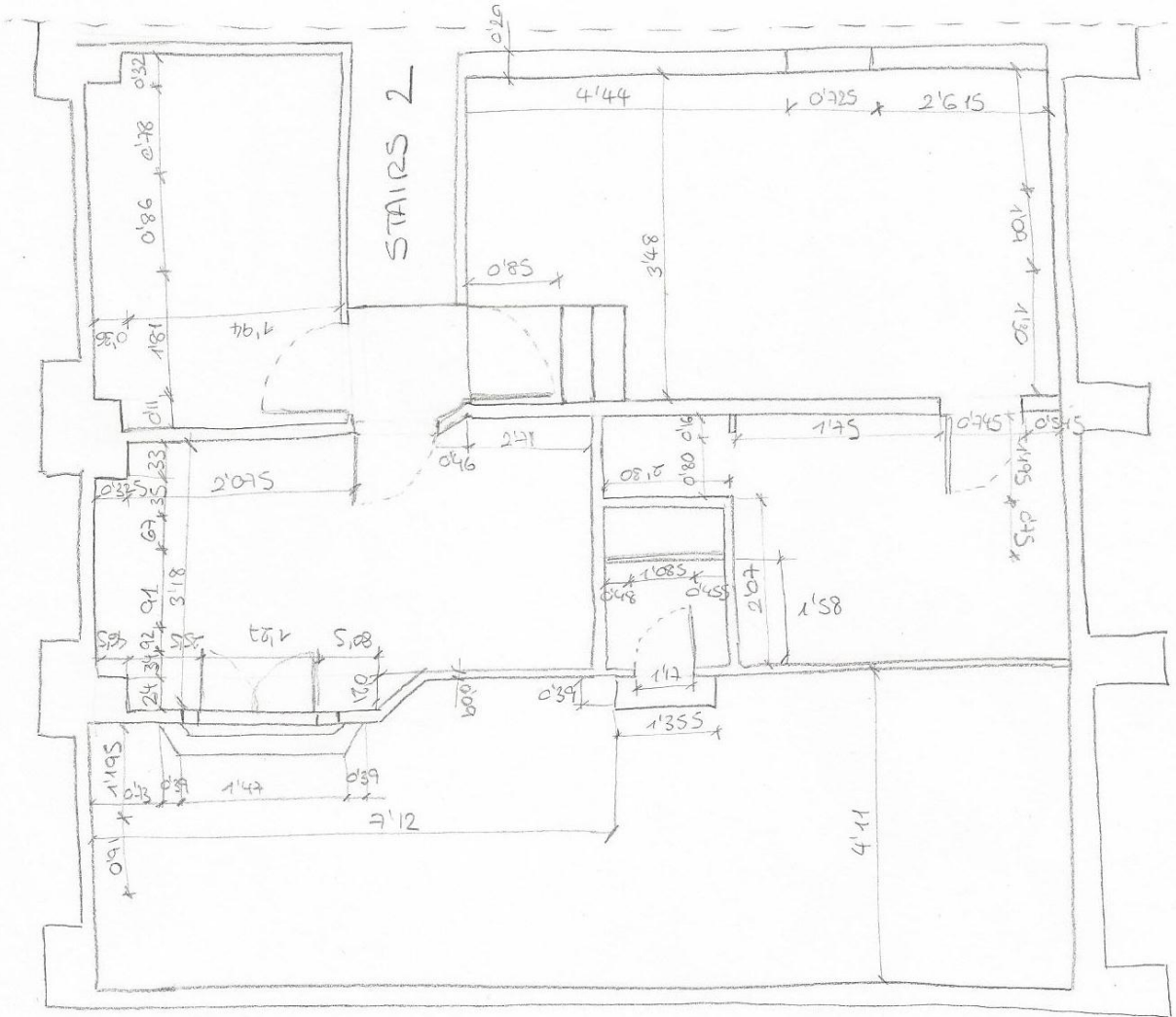

# STAIRS 1

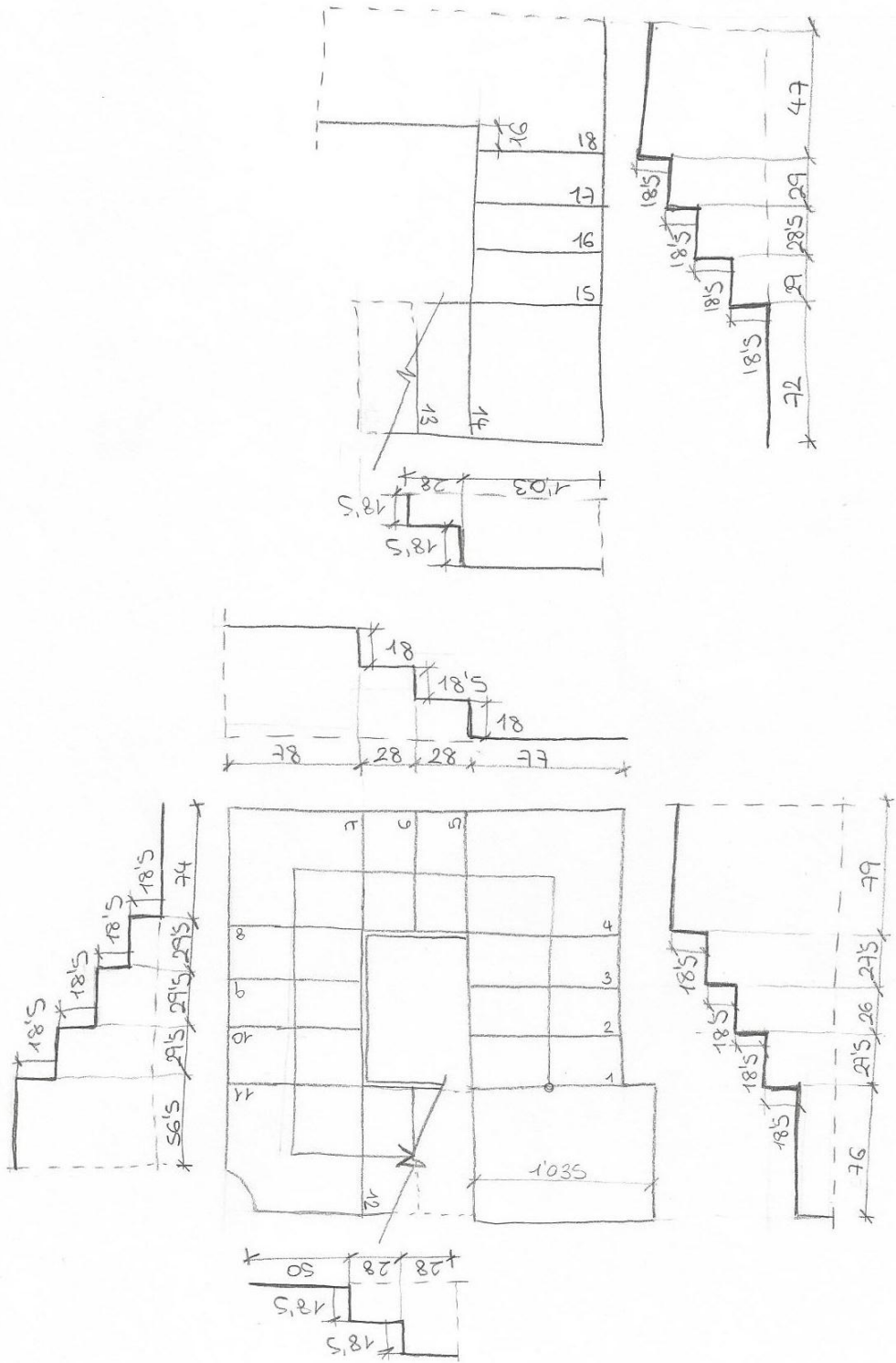

# STAIRS 2

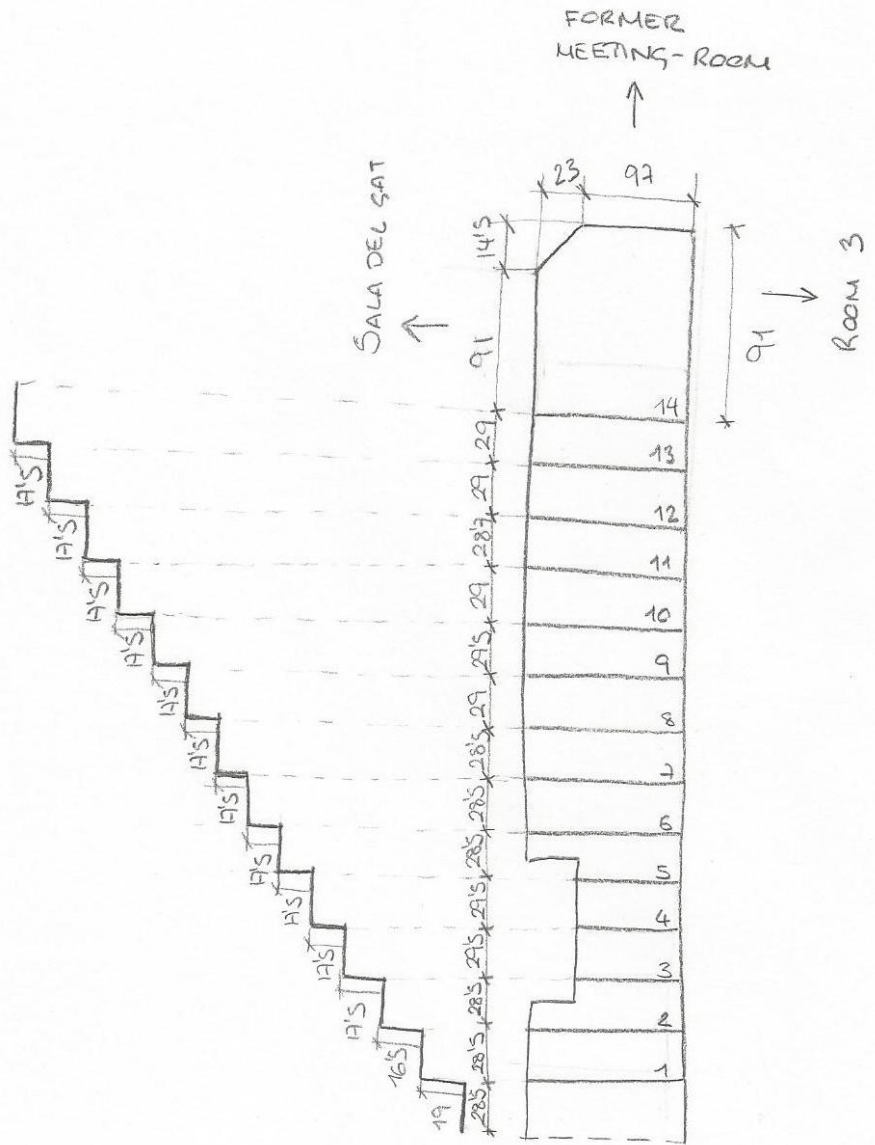



# EXTERIOR STAIRS

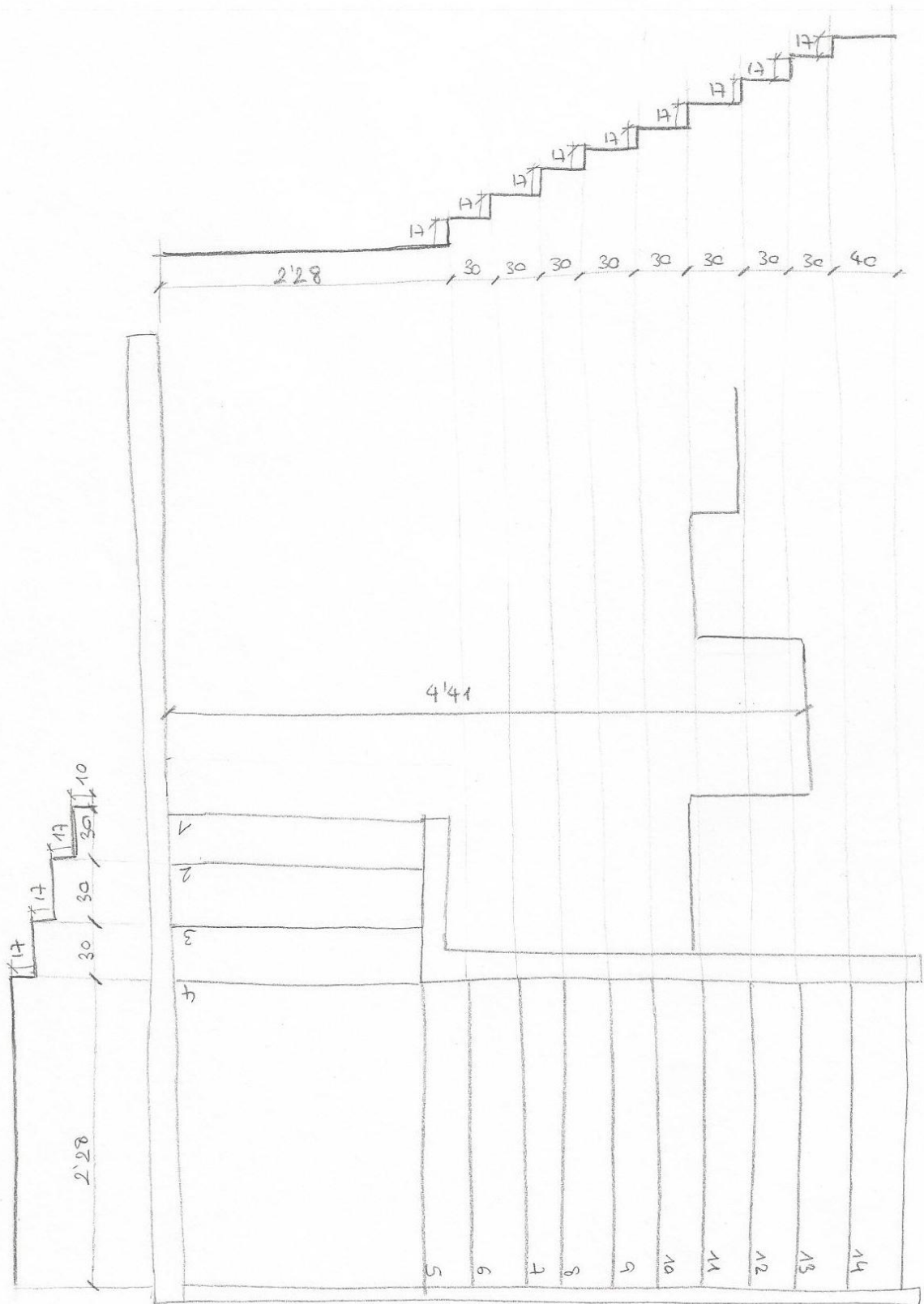

# NORTH FAÇADE

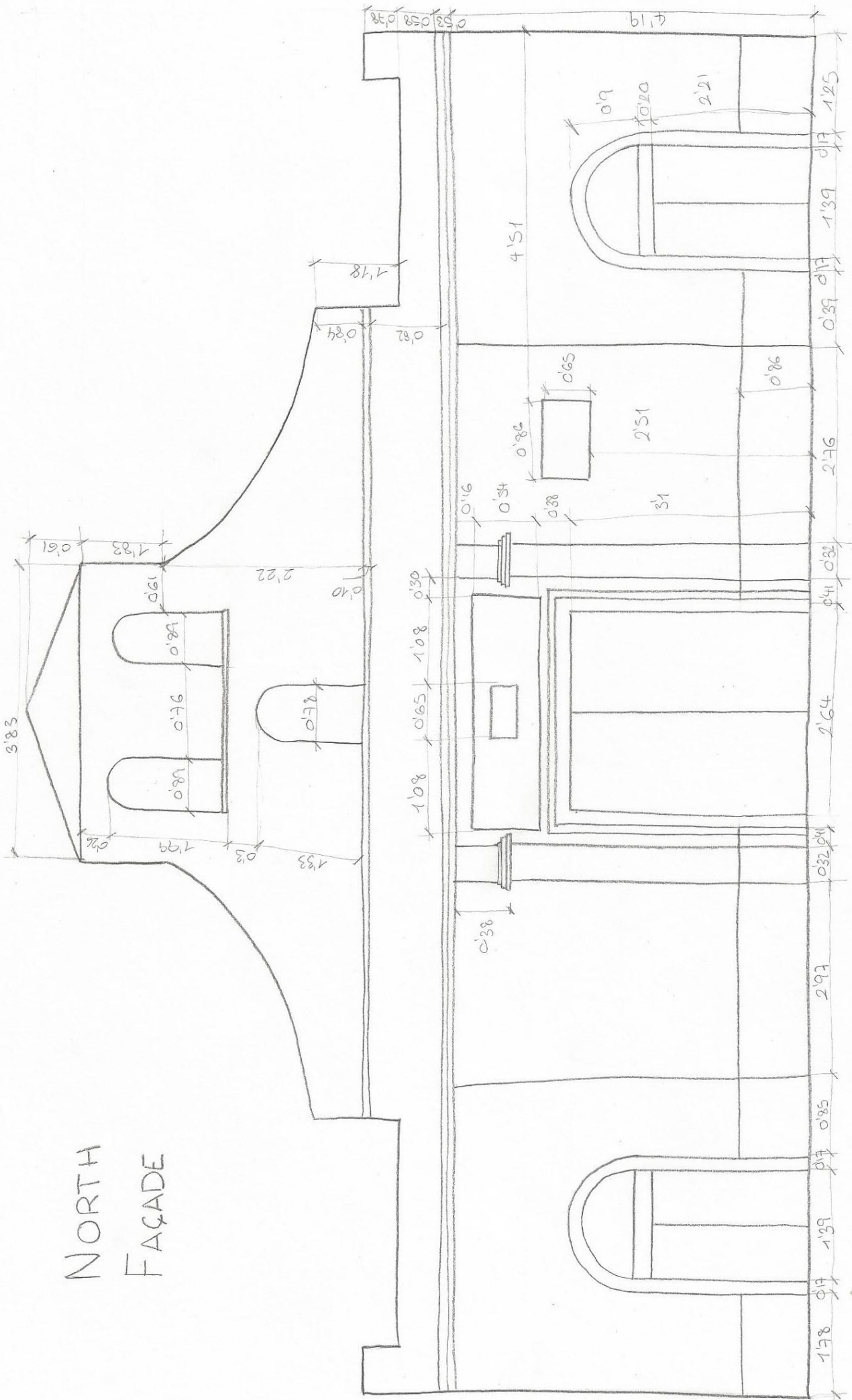

# WEST FAÇADE

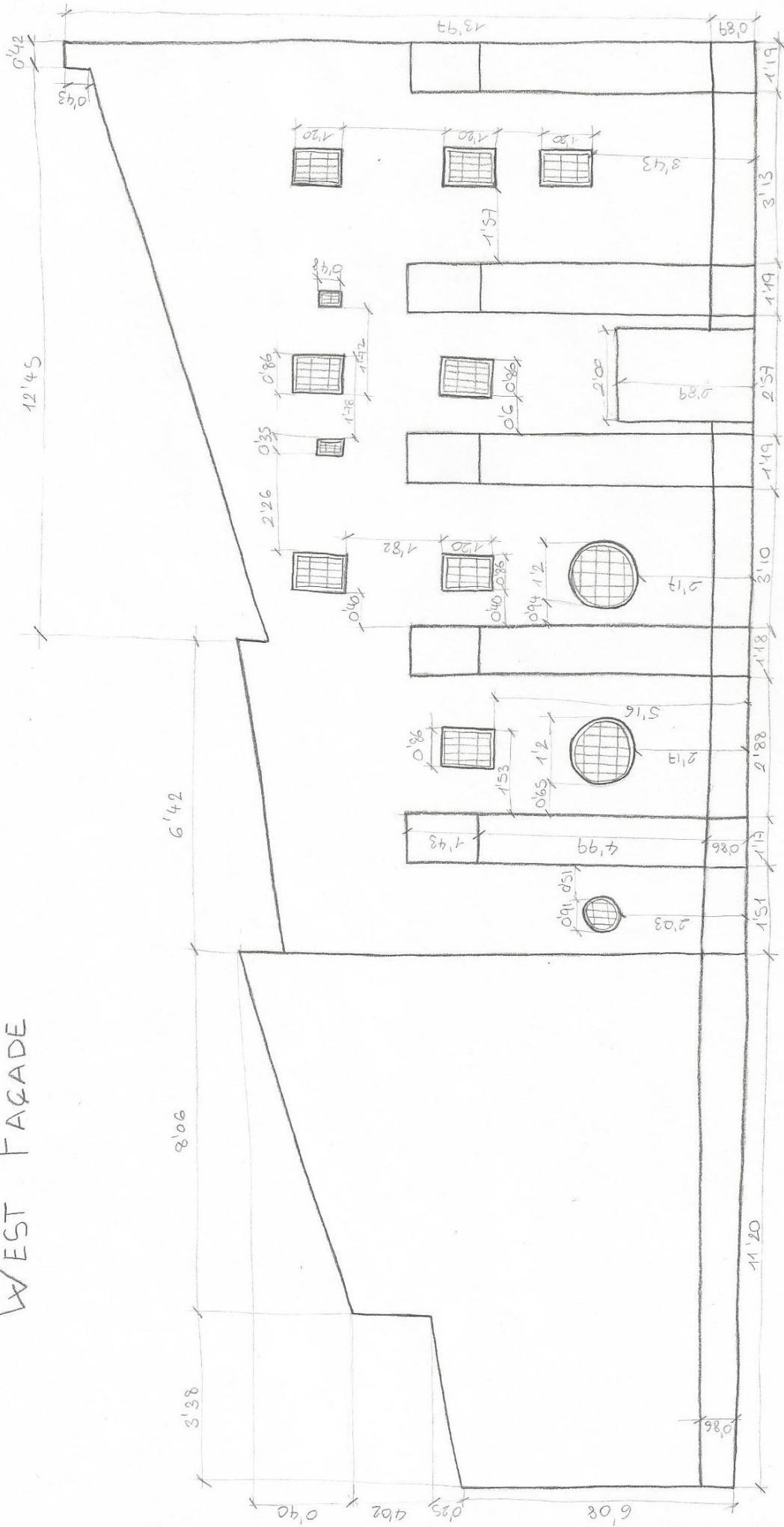

# SOUTH FAÇADE

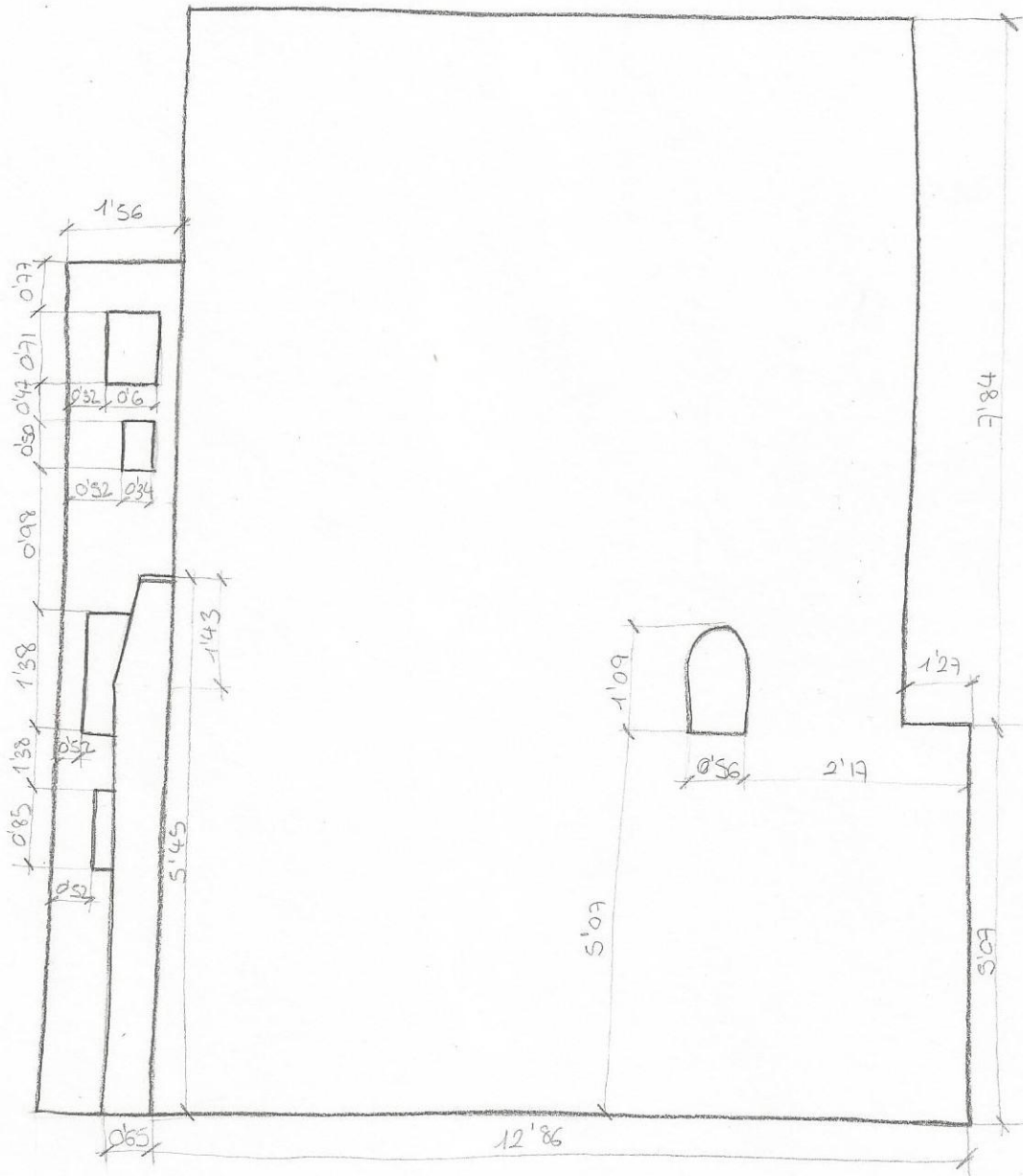

# EAST FAÇADE

