



VILNIUS GEDIMINAS TECHNICAL UNIVERSITY
FACULTY OF CIVIL ENGINEERING
DEPARTMENT OF CONSTRUCTION TECHNOLOGY AND MANAGEMENT

Student: Cristina, Salvador Zaragoza

Supervisor: Jonas Sparauskas

Language – English

Daugiabučio gyvenamojo namo Vingrių g. 3A, Vilniuje statybos projektavimas
Construction planning of multi-dwelling residential building at Vingriai str. 3A in Vilnius

FINAL THESIS WORK

VILNIUS, 2014

VILNIUS GEDIMINAS TECHNICAL UNIVERSITY
FACULTY OF CIVIL ENGINEERING
DEPARTMENT OF CONSTRUCTION TECHNOLOGY AND MANAGEMENT

APROVED

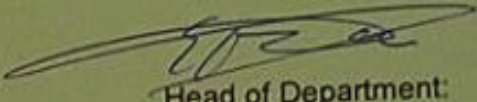

Head of Department:

Edmundas Kazimieras Zavadskas

Student: Cristina Salvador Zaragoza

Daugiabučio gyvenamojo namo Vingrių g. 3A, Vilniuje statybos projektavimas
Construction planning of multi-dwelling residential building at Vingriai str. 3A in Vilnius

FINAL THESIS WORK

Supervisor: Jonas Saparauskas.....date:

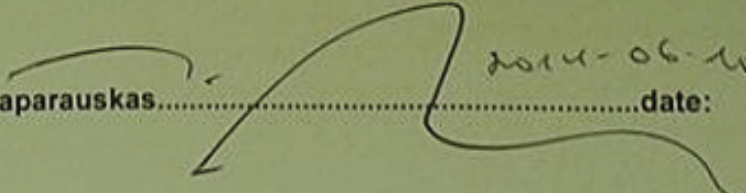

2014-06-10

VILNIUS, 2014

VILNIUS GEDIMINAS TECHNICAL UNIVERSITY
FACULTY OF CIVIL ENGINEERING
DEPARTMENT OF CONSTRUCTION TECHNOLOGY AND MANAGEMENT

Study area: CIVIL ENGINEERING
Study program: CONSTRUCTION MANAGEMENT
Specialization: CONSTRUCTION TECHNOLOGY AND
MANAGEMENT

APPROVED
Head of Department

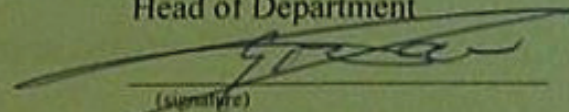

Edmundas K. Zavadskas
(name and surname)

THE TASK OF FINAL BACHELOR'S THESIS

.....No.
Vilnius

Student: *Cristina SALVADOR ZARAGOZA*

The title of final thesis: *Construction planning of multi-dwelling residential building at Vingriai str. 3A in Vilnius.*

Approved: *2014-04-04 by Dean's order No 149st*

The term of completion of the Thesis: *10 of June 2014.*

THE TASK OF FINAL THESIS

Initial information: architectural drawings.

Workbook

Architectural Part. describe characteristics of building under construction and building plot. Make calculation of frame.

Technological and Organizational Part. compile technological cards for making facade, installing of floor and roof. Perform calculations of construction masterplan, compile schedule of whole construction process.

Economical Part. Perform calculations of costs for all three technological cards.

Drawings

Architectural part - 1 item; Technological cards - 3 items; Construction masterplan - 1 item; Construction schedule - 2 item.

Supervisor

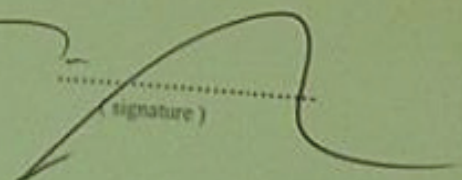

.....
(signature)

I got the Task

.....
(signature)

Cristina SALVADOR ZARAGOZA
(name and surname)

2014-04-04
(date)

Assoc Prof Dr Jonas Šaparauskas
(given name and surname, academic degree and name)

(the document of Declaration of Authorship in the Final Degree Project)

VILNIUS GEDIMINAS TECHNICAL UNIVERSITY

Cristina Salvador Zaragoza, 20140022

(Student's given name, family name, certificate number)

Faculty of Civil Engineering

(Faculty)

Construction Technologies and Management, STVino-12

(Study programme, academic group no.)

**DECLARATION OF AUTHORSHIP
IN THE FINAL DEGREE PROJECT**

June 6, 2014

I declare that my Final Degree Project entitled „Construction planning of multi-dwelling residential building at Vingriai str. 3A in Vilnius” is entirely my own work. The title was confirmed on April 4, 2014 by Faculty Dean's order No. 149st. I have clearly signalled the presence of quoted or paraphrased material and referenced all sources.

I have acknowledged appropriately any assistance I have received by the following professionals/advisers:
Assoc Prof Dr Jonas Šaparauskas.

The academic supervisor of my Final Degree Project is Assoc Prof Dr Jonas Šaparauskas.

No contribution of any other person was obtained, nor did I buy my Final Degree Project.

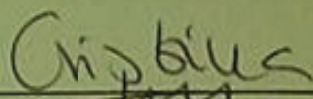

(Signature)

Cristina Salvador Zaragoza

(Given name, family name)

Vilniaus Gedimino technikos universitetas
Statybos fakultetas
Statybos technologijos ir vadybos katedra

ISBN ISSN
Egz. sk.
Data-.....-.....

Pirmosios pakopos studijų **Statybos technologijų ir valdymo** programos bakalauro baigiamasis darbas 3
Pavadinimas **Daugiabučio gyvenamojo namo Vingrių g. 3A, Vilniuje statybos projektavimas**
Autorius **Cristina Salvador Zaragoza**
Vadovas **doc. dr. Jonas Šaparauskas**

Kalba: anglų

Anotacija

Šio baigiamojo darbo tikslas yra "Daugiabučio gyvenamojo namo Vingrių g. 3A, Vilniuje statybos projektavimas"

Baigiamąjį darbą sudaro trys dalys:

- Architektūrinė dalis, kurią sudaro trumpas aiškinamasis raštas ir grafinė medžiaga (fasadų, vertikalių ir horizontalių pjūvių ir situacijos plano brėžiniai);
- Technologinė dalis, kurią sudaro trys skirtingi darbai: o fasado įrengimas o grindų įrengimas o stogo įrengimas;
- Organizacinė dalis, Statybos pagrindinio plano aprašymas ir Statybos planavimas.

Baigiamąjį darbą sudaro:

Aiškinamasis raštas: 74 A4 puslapiai

Brėžiniai: 6 A1 lapai

Prasminiai žodžiai: Nauja statyba, technologijos, fasadų, grindų, stogo, planavimas, sauga, sluoksniai, biudžetas, organizavimą.

Vilnius Gediminas Technical University
Faculty of Civil Engineering
Department of Construction Technology and Management

ISBN ISSN
Copies No.
Date-.....-.....

Bachelor Degree Studies **Construction Technologies and Management** study programme Bachelor Graduation Thesis 3

Title **Construction planning of multi-dwelling residential building at Vingriai str. 3A in Vilnius**
Author **Cristina Salvador Zaragoza**
Academic supervisor **Assoc Prof Dr Jonas Šaparauskas**

Thesis language:
English

Annotation

The purpose of this final work is the "Construction planning of multi-dwelling residential building at Vingriai str. 3A in Vilnius"

This final work consists of three parts:

- The architectural part consists in a brief description of the building with written report and graphical information (drawings of facades, vertical and horizontal sections and situation map).

- Technological part, consists about three different works:

- Installation of the facade
- Installation of the flooring
- Installation of the roof

- Organization part, description of Construction Master plan and Construction scheduling.

The Final Thesis Work consists of:

Explanatory text: 74 A4 pages

Draws: 6 A1 drawing

Keywords: New construction, technology, facade, floor, roof, scheduling, safety, layers, budget, organization.

Agradecimientos:

A la Universidad Politécnica de Valencia y a la Vilnius Gediminas Technical University por guiarme a lo largo de mi carrera universitaria y sobre todo durante la elaboración de este Proyecto Final de Grado.

A mis amigos y familiares que desde España han estado apoyándome en todo momento, a mis padres Vicente y María Dolores que primero desde España y ahora en Vilnius han estado a mi lado, a mi hermana María que también estuvo aquí, a toda la gente que he conocido aquí en Vilnius, y finalmente a David Gadas con el que he compartido todo este periodo de Erasmus.

1. ARCHITECTURAL PART	3
1.1 INTRODUCTION.....	3
1.2 LOCATION.....	4
1.3 HISTORICAL OVERVIEW.....	7
1.3 FIELD.....	8
1.4 DISTRIBUTION OF FLOORS	8
1.5 CONSTRUCTION MEMORY	13
1.5.1 FOUNDATION.....	13
1.5.2 COLUMNS.....	13
1.5.3 SLABS	14
1.5.4 STAIRS	14
1.5.5 FLOORS	14
1.5.6 FAÇADE	14
1.5.7 ROOF	14
1.5.8 INTERNAL PARTITIONS.....	14
1.5.9 INSTALLATIONS.....	14
1.5.10 FIRE SAFETY	15
1.5.11 HEALTH CONDITIONS.....	16
1.5.12 ENVIRONMENT	16
1.5.13 INSULATION.....	16
1.5.14 DISABILITY NEEDS.....	16
1.5.15 LIFT AND MACHINERY.....	16
2. TECHNOLOGICAL CARDS	17
2.1 TECHNOLOGICAL CARD I, FACADE WORKS	17
2.1.1 GENERAL DESCRIPTION.....	17
2.1.2 DESCRIPTION OF TECHNOLOGY AND SEQUENCE OF WORKS	17
2.1.3 LOCATION OF THE DIFFERENT TYPES OF FACADE	23
2.1.4 HUMAN SAFETY	25
2.1.4 QUALITY CONTROL	26
2.1.6 ORGANIZATION OF WORKS OF FACADE	27
2.1.6 MATERIAL AND TECHNICAL RESOURCES OF ALL FACADE WORKS	28
2.1.7 CALCULATION OF THE PRICE FOR FAÇADE WORKS.....	29
2.1.8 TECHNICAL – ECONOMIC INDICATORS.....	32
2.2 TECHNOLOGICAL CARD II, FLOORING WORKS	34
2.2.1 GENERAL DESCRIPTION	34
2.2.2 DESCRIPTION OF TECHNOLOGY AND SEQUENCE OF WORKS.....	34
2.2.3 HUMAN SAFETY.....	42
2.2.4 QUALITY CONTROL	43

2.2.5	ORGANIZATION OF WORKS OF FLOORING IN SECOND FLOOR	44
2.2.6	MATERIAL AND TECHNICAL RESOURCES OF ALL FLOORING WORKS	45
2.2.7	CALCULATION OF THE PRICE FOR FLOORING WORKS	46
2.2.8	TECHNICAL – ECONOMIC INDICATORS	49
2.3	TECHNOLOGICAL CARD III, ROOF WORKS	50
2.3.1	GENERAL DESCRIPTION	50
2.3.2	DESCRIPTION OF TECHNOLOGY AND SEQUENCE OF WORKS	50
2.3.3	LOCATION OF TERRACE AND VENTILATION DUCT	56
2.3.4	HUMAN SAFETY	57
2.3.5	QUALITY CONTROL	58
2.3.6	ORGANIZATION OF WORKS OF ROOF	59
2.3.7	MATERIAL AND TECHNICAL RESOURCES OF ALL ROOF WORKS	60
2.3.8	CALCULATION OF THE PRICE FOR ROOF WORKS	61
2.3.9	TECHNICAL – ECONOMIC INDICATORS	62
3.	ORGANIZATION PART	64
3.1	ANALYSIS OF CONSTRUCTION MASTERPLAN	64
3.1.1	DESCRIPTION OF THE TERRITORY	64
3.1.2	SELECTION OF THE CRANE	65
3.1.3	SETTING OF DANGEROUS ZONE	69
3.1.5	TEMPORARY ACCESS TO THE WORK SITE	71
3.1.6	TEMPORARY STORAGE AREAS	71
3.1.7	TEMPORARY BUILDINGS FOR WORKERS AND MANAGING STAFF	72
3.1.8	TEMPORARY ELECTRICITY SUPPLY	72
3.1.9	CONSTRUCTION SITE LIGHTNING	73
3.1.10	TEMPORARY ELECTRICITY SUPPLY	73
3.1.11	CONSTRUCTION SITE LIGHTNING	73
3.1.12	TEMPORARY WATER SUPPLY	74
3.1.13	TEMPORARY SEWERAGE	75
3.1.14	FENCE OF CONSTRUCTION FIELD	75
3.1.15	GENERAL REQUIREMENTS OF LABOR SAFETY	75
3.1.16	ENVIRONMENTAL PROTECTION REQUIREMENTS	76
3.1.17	FIRE PROTECTION REQUIREMENTS	77
4.	BIBLIOGRAPHY	78

1. ARCHITECTURAL PART

1.1 INTRODUCTION

The objective of this final thesis work is the construction of multi-dwelling residential building in Vilnius, in Vingriu Street 3a.

The project is intended to improve an incomplete form of the Old Town district urban structure. The building is designed in order to make an optimum use of the space, due to the plot is placed in a corner, the construction of the building extends the street Vingrių, forming an alley and a courtyard in the back side.

The building is not only as a balanced blend in this local environment but also suitable for living (see Figure 1.)

The project is a four storey building with attic apartment, and two underground floors. It consists in three independent blocks of apartments.

Ground floor will contain four commercial premises for different kind of business. From first floor to attic floor, it will be for apartments. Altogether the building contains thirty six apartments. The building will be provided with thirty three underground parking places and twenty five pantries.

All apartments are designed to have balcony or terrace; attic floor ceiling is installed higher than usual, so the sensation of space will be even greater. First floor residents will enjoy coming out to the courtyard spacious.

As regards the areas, the building shape is not as large as lot area, we have to take in mind that it exist a courtyard. However the building consist in different heights so the total built area is largest.

Surfaces:

Plot's area: 1679.4116 m²

Shape building area: 841.0892 m²

Building area: 4399.64m²

The solutions of different works in the building are adopted according to Spanish standards.



Figure 1. Virtual view of building

1.2 LOCATION

The building is located in Vilnius, Lithuania.

Lithuania is a Northeastern Europe country that borders Latvia by the north, Belarus by the east, Russia and Poland by the south and in the west side it borders by Baltic Sea (see Figure 2).

Lithuanian's climate is maritime – continental, due to Vilnius is sited in the east of Lithuania, the prevailing climate is the continental. It is characteristic of this type of climate seasonal temperatures differences, cold winters and warm summers.

Vilnius is the capital of Lithuania, it counts with 539,939 of population and it has an area of 401 km².

In the following image we can find the location of Vilnius in Lithuania map.



Figure 2. Vilnius Location

The specifically location of the building is in Vilnius Old Town (Lithuanian: Vilniaus Senamiestis) and as we discussed above, it is sited in a corner between Vingriu Street and an unnamed alley.

We can find in the following images on the one hand the Old Town area and the location of the building (see Figure 3) and in the other hand the location of the plot (see Figure 4).

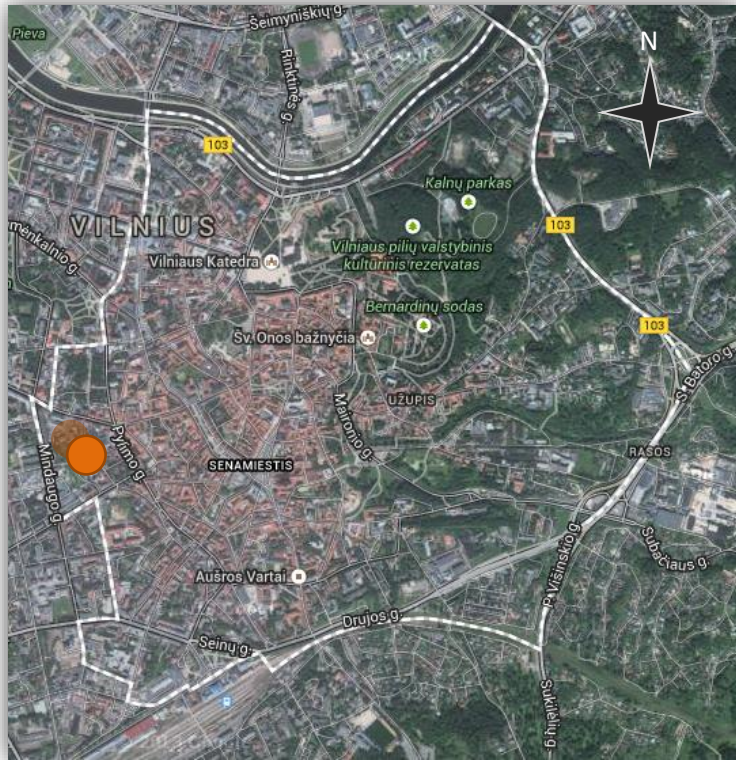

Figure 3. Aerial view of building location



Figure 4. Aerial view of plot location

1.3 HISTORICAL OVERVIEW

The building belongs to Vilnius Old Town district.

First mentioned in historical sources in 1323 by the Grand Duke Gediminas, Vilnius has grown into a medieval capital city with radial network of meandering streets, pretty courtyards and an impressive array of architecture.

The buildings of the Old Town (there are about 1500 of them) were built over a number of centuries making it a mix of different architectural styles, from Gothic to Classicism. Nevertheless, Vilnius is often referred to as a Baroque city.

Vilnius is the result of the development of the Balts' culture, however, its influence on and significance to the history of Belarus, Ukraine and Poland are unquestionable.

In 1994 the Vilnius historic centre, covering the area of 359.5 ha, was inscribed on the *UNESCO World Heritage List* under No 541 in recognition of its universal value and originality.

In 1995 the International Bank for Reconstruction and Development provided technical and financial assistance to the Vilnius City Municipality in drawing up the unique programme of protection and revitalisation of the urban heritage "*Vilnius Old Town Revitalisation Strategy*".

The *UNESCO World Heritage Centre* wanted to see the process of Vilnius Old Town revitalisation as a model to be applied to other historic centres of the cities of Eastern and Central Europe. Actually, in the following 14 years after preparing that document it should be admitted that these ambitious objectives have not been fully achieved.

Following a review of the Architect.



Tauras Paulauskas, Architect:

"In this situation, I'm clearly the only one conservationists at Vilnius City Municipality, the chief architect of the requirement of wooden windows. Additionally, I am categorically against the plastic windows of the capital's districts; Senamiestyje, Naujamiestyje, Žvėryne, Užupyje. Plastic windows are the evil in historical architecture. About the cover of roof, copper is certainly not the only and unique roofing material, especially common in Vilnius. In our city simple tiles are more common. Copper after all, quickly becomes black, and the effects of acid rain on after a few decades. Vilnius has never been characterized by shiny roofs, copper was covered only once the royal palace. This shows that already in antiquity Vilnius saved, and today copper is also a luxury item. If you want to have something very similar to copper, nowadays exist a variety of substitutes, imitations, and certainly not worth the spend."

Due to the historical location of plot, part of it is on archaeological excavations discovered during the seventeenth century. This fact carries to meet requirements of Department of Cultural Heritage.

To perform archaeological research is required qualified professionals in this field. However after studies, no human bones, nor old building's foundations were found.

Consequently, the construction is permitted without additional long lasting archaeological research or conservation.

1.3 FIELD

As we explained above, the total area of the plot is 1,679.4116 m² but only 841.0892 m² are occupied by shape of building.

Due to the plot is placed in a corner there are two adjacent buildings. By southern there are one old building, both, the new one and the old one will share a wall. By eastern the limit is not with other building but with a facade. This new façade will form with the other building a new alley. The overall shape of the building forms a courtyard.

The building shape area is 841.0892 m² forming an irregular polygon according the best use of the territory.

The main building facades are Vingriu Street façade and unnamed alley façade. In each one we can find access to the building and in the unnamed alley façade we can also find the parking access.

In all, there are three access, above we showed where two of them are placed, and the third one is in the new alley formed between our building and the adjacent old building.

During works, the access for machinery will be by Vingriu Street side.

A cause of the sloped field in some places of the plot we will dig more than in others. Moreover, due to the type of terrain the strongest layer that can support the foundation is very deep.

In reference to the height of the building, it is distributed along four floors in one side and along five floors in other side, including in both cases the attic floor. There are also two underground floors for parking. The highest part of the building is 14.30 m. and the lowest level is - 4.20 m.

1.4 DISTRIBUTION OF FLOORS

In order to make better use of the solar surface the shape of the building is an irregular polygon. It forms a special shape that allows having different facades, not only in the main streets but also in a new alley and backyard that itself form.

Altogether there are six facades, two main facades and four secondary facades. However, as we have mentioned above, there are three main entrances to the building, one in each main façade and other one in the new alley formed between our building and the old adjacent building.

The access to the parking is in the unnamed alley façade provided by a ramp.

In each access we can find stairs and in the western façade access we can find also a gift.

In the second underground floor, aside from having parking area there are also some places reserved for facilities as a reservoir, which is at a lower altitude; a technical room; introduction to communication; water introduction and pumping.

Due to the sloped plot, we can also find in this level two specialized salon for commercial use. The access to this locals is from Vingriu Street.

The first underground floor is also parking area, 13 spaces, with second underground parking area totally 37 places; and one commercial room more where you can access from Vingriu Street too. In this level is placed the thermal unit and garbage containers.

About first floor, first of all say that in the eastern side is at 0.00 m and in the western side it is at +1.75 m. This difference of height is along the whole building, in every floor.

Other important thing to say is that whereas in eastern side the height increases 3.30 m by 3.30 m in the western side it only increases 3.00 m by 3.00 m each floor.

From first floor till the attics the main use of the building is for apartments. Each apartment is provided with different number of rooms, but all of them have kitchen, a place for rest and one bathroom at least. Additionally, all of them have different area.

There are 36 apartments in the building.

Following we will show areas of second floor (see Table 1 and Figure 5).

APART.No	ROOM NAME	ROOM AREAS (m ²)	BALCONY AREAS (m ²)	TOTAL AREA (m ²)
2_1				
	1. Kitchen/Living room	33.89		68.53
	2. Room	9.13		
	3. Bath room	3.98		
	4. WC	2.02		
	5. Room	19.51		
2_2				
	1. Kitchen/Living room	36.13		82.88
	2. Room	3.84		
	3. Bath room	4.24		
	4. WC	1.68		
	5. Room	13.57		
	6. Room	23.42		
	7. Balcony		3.21	
2_3				
	1. Kitchen/Living room	37.52		82.58
	2. Room	17.58		
	3. Bath room	6.06		

	4. Room	21.42		
2_4				
	1. Kitchen/Living room	33.96		73.79
	2. Bath room	3.96		
	3. Corridor	3.39		
	4. Room	22.12		
	5. Room	6.94		
	6. WC	3.42		
	7. Balcony		4.29	
2_5				
	1. Kitchen/Living room	30.23		62.47
	2. Corridor	7.44		
	3. Bath room	4.16		
	4. WC	2.14		
	5. Room	18.5		
	6. Balcony		5.59	
	7. Balcony		7.12	
2_6				
	1. Kitchen/Living room	30.63		84.9
	2. Corridor	7.79		
	3. Room	16.52		
	4. Bath room	4.35		
	5. WC	1.98		
	6. Room	23.63		
2_7				
	1. Kitchen/Living room	28.49		70.81
	2. Room	17.64		
	3. Bath room	5.95		
	4. Room	18.73		
	5. Balcony		4.27	
2_8				
	1. Kitchen/Living room	32.01		66.46
	2. Corridor	7.23		
	3. Bath room	6		
	4. Room	21.22		
	5. Balcony		4.27	
2_9				
	1. Kitchen/Living room	37.06		69.33
	2. Corridor	10.7		
	3. Bath room	6		

	4. Room	15.57		
	5. Balcony		4.27	
			TOTAL APARTMENT	661.75

Table 1. Areas of second floor apartments



Figure 5. Top view of second floor

1.5 CONSTRUCTION MEMORY

1.5.1 FOUNDATION

Due to the resistant surface is deep, the better kind of foundation in this case is piles. To connect with the surface there is piles cap.

This system of foundation consists in look for the resistant layer capable to absorb the loads transmitted by the building. The piles cap is used so as for working together both piles.

The piles receive mainly vertical loads from the structure, this loads from the column is transmitted to the piles by the cap piles. At the same time the piles working by friction with the ground, generating loads in the opposite direction of the column.

According the normative, the type of concrete used is HA-25 (characteristic resistance $f_{ck}= 25$ MPa) and the type of iron for the arms is B500S (characteristic resistance $f_{yk}= 500$ MPa)

The following image shows how works this kind of foundation according EHE.08.

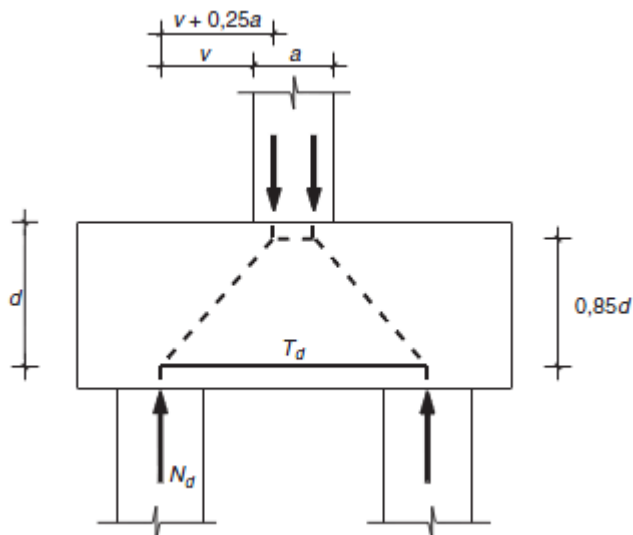

Figure 6. Loads direction in piles foundation

After drilled foundations, in underground floors are bearing walls and columns in the perimeter in order to hold the ground.

In this case, the cape piles are strip along the entire wall.

1.5.2 COLUMNS

Monolithic columns with square cross section made of reinforced concrete. The distance between columns is variable.

Should be noted, as we explain above, that in underground floors, in the entire perimeter, as well columns there are bearing walls.

It will be done according EHE-08.

1.5.3 SLABS

Monolithic reinforced concrete slab. As a structural concrete element, it follows the EHE-08 standards. The type of concrete used is HA-25 and B400S type of steel as reinforcement.

The slab is 250 mm.

1.5.4 STAIRS

The stairs and the stairs case is also a monolithic element built by reinforced concrete.

1.5.5 FLOORS

Depend on the rooms and areas, the coatings will be different such as their characteristics. The selected coatings are not available in the received information.

1.5.6 FAÇADE

The façade finish coating is ceramic tiles fixed by technical glue. As thermal and sound insulation the material used is rock wool. The supporting element of façade layers is expanded clay bricks.

In order to provide light to the interior, along the façade we can find large wooden windows and some balconies with forged metal railing.

1.5.7 ROOF

It is a pitched roof composed by metal slabs HEB and wood slabs structure. The finish coating is done with ceramic tiles.

As thermal and sound insulation it is used XPS also named Styrofoam.

1.5.8 INTERNAL PARTITIONS

It is executed by ceramic bricks and the finish coating is plaster. According to the places, the thickness of the wall will be different.

1.5.9 INSTALLATIONS

All engineering building is connected to the communication network in accordance with the city engineering design conditions with the technical terms.

Equipped with the general premises consumption of energy accounting. Each apartment will have an electrical panel with all necessary automatic switches. The apartment has electric wires hidden distribution and assembly of the box. Electric sockets and switches as mounting boxes and chandeliers number expected by the project.

Equipped with low voltage networks (TV, telephone, Internet) distribution panel. From his apartment lay PVC pipe installation. Installed in conversation, the front door opened, the handset (Intercom). The apartments are fitted with fire alarms.

The building is heated from the Vilnius district heating network.

Introduction of water will be used from Vingrių street. Pipeline of water is running adjacent to the garage.

The existing pipeline is removed from his site because of the built-up area.

The new pipeline inlet, start expected from the existing low-pressure polyethylene pipeline Ø16 mm at Vingrių Street.

Rain water will be connected to the renovated gravity sewer networks.

1.5.10 FIRE SAFETY

The building project is designed in accordance with the STR 2.01.04:2004 fire safety. Basic requirements' STR 2.02.01:2004 "Residential buildings".

The roof wooden structure is impregnated with long-term effects of fire-fighting material blend to hard-combustible timber group structure from the inside lined with 2 layers of cardboard sheets.

Underground parking from projected residential and commercial space separated REI 150 fire resistance floor.

Staircases are separated from the parking REI 150 reaction to fire walls and 60 EI reaction to fire doors.

Technical rooms are separated from the garage area EI 45 and EI 30 divisions in the door.

All fire doors providing the sealing washers and self-closing mechanisms.

The building contains sprinkler as fire extinguishing systems. Sprinkler system water supply designed to ensure 150m³ underground water reservoir.

For remove the smoke from the parking lot during a fire is designed a mechanical smoke removal system.

One underground parking floor from another fire will be separated by a self-closing fire doors EI60.

The building is designed with automatic fire alarm system. Apartments and commercial premises provides thermal and optical smoke detectors. Staircases, on each floor, the expected hand fire alarm buttons and fire alarms.

The court will be able to enter a car fire in the western part of the plot.

Outside the building fire safety shall be provided from two existing underground hydrants installed on the water supply.

1.5.11 HEALTH CONDITIONS

The building has been designed to meet the habitability standards, according to the Lithuanian regulations:

STR 2.01.01(3):1999, „Essential requirements of the building. Hygiene, health, protection of the environment”.

STR 2.01.01(5):2008, „Essential requirements of the building. Protection against noise”.

STR 2.01.01(4):2008, „Essential requirements of the building. The safety of use”.

1.5.12 ENVIRONMENT

The building has been designed to meet the habitability standards, according to the Lithuanian regulations:

STR 2.01.01(3):1999, „Essential requirements of the building. Hygiene, health, protection of the environment”.

1.5.13 INSOLATION

Insolation calculations are made based on STR 2.02.01:2004 "Residential buildings"

According to STR 2.02.01:2004 "Residential Buildings:

Each 1-3 apartment must have at least one room in which between 22 March – 22 September, potential insolation is at least 2.5 hours. In urban areas, according to the existing layout of buildings, the overall insolation time can be reduced to 2 hours.

1.5.14 DISABILITY NEEDS

The building has been designed to meet the disability need requirements standards, according to the Lithuanian regulations:

STR 2.02.02:2004 “Public buildings”.

STR 2.02.01:2004 “Residential buildings”.

1.5.15 LIFT AND MACHINERY

As we noted earlier, the eastern entrance is provided with an elevator which have access to all floors, also underground floors.

2. TECHNOLOGICAL CARDS

In this part of the final work we explain in detail three construction processes to the resources used and time taken to complete it. The three parts of the execution of the building selected are façade, flooring and roof.

2.1 TECHNOLOGICAL CARD I, FACADE WORKS

2.1.1 GENERAL DESCRIPTION

As we can see in the building plans, there are different types of facade areas, therefore the objective of the first technological card is to describe the different layers of the façade in each area as well as the construction process.

We can find in the facade different types of finishing coat as:

- Ceramic tiles
- Glazed ceramic tiles
- Plaster
- Rustic plaster

In following parts of hte work, we will explain each layer of the facade as well as the different finishing coat that we can find. But we are going to calculate budget and works duration only for ceramic tiles type.

Taking in account the plans there are seven façades totaling 1,915.38 m².

It's also important to explain the layers of the wall which connects the new building studied in this thesis with the old one already placed in the neighboring plot.

2.1.2 DESCRIPTION OF TECHNOLOGY AND SEQUENCE OF WORKS

The façade is built from inside out, allowing the work to be performed simultaneously inside (finishes, flooring, partition walls, plaster ...) and the outer face thereof.

Following it is described all layers used to perform the façade with graphical information.

Preparation of the base and stakeout of the bricks:

To start the works on the concrete structure it is convenient to clean the surface before start. This practice is a good guarantee to keep the wall vertical.

After cleaning it is important to make the stakeout of the bricks in order to know the exact position of them. It will be done from brick axis.

Decoupling layer:

The façade and the slab should be as independent as possible to prevent cracking thereof, due to structure movements.

To get it, it slips an elastic sheet on the slab under the first line of bricks.

Main layer:

As we mentioned above the façade is composed by one leaf, it means that there are only one layer of bricks.

According the area of the façade, because of the geometrics thereof, the thickness is different. Thus, these differences are solved using different thickness bricks. We can find 250 mm bricks and 100 mm bricks.

It is important to keep the verticality of the wall. For it we use canvas and sinker during bricks layer works.

According Spanish standards we have to take in mind the following steps:

- Bricks wetting. In order to keep the consistence of the mortar, it is good practice wetting the bricks with the exact amount of water. The mortar can not get more water neither lose its water.
- Laying bricks. Due to the peculiar form of the expanded clay bricks, the way to lay it is verticaly, abutting the tongue and groove, leading to form special vertical joints without mortar.
- Joint filling.

The wall should run in horizontal rows. In consecutive rows, the bricks should be underhand.

The lintel will be make with metal sections, in addition, it have to be reinforced by steel armour.

Thermal and sound insulation:

Due to the building is placed in a geographical zone with cold weather, it is necessary to use substantial thermal insulation layer.

In order to grant a suitable insulation against the heat, there are two leafs of thermal insulation, altogether the thickness of the thermal layer is 170 mm.

It is important to take care about the thickness of the thermal insulation because it is the main layer to keep the building warm.

According the project information, the material used is mineral wool.

The structure of mineral wool consists in a mat of fibres which prevents the movement of air and coupled with its long-term stability, gives it the ability to combat noise pollution and promote safety by reducing the risk of fire.

Finish coatings:

We use a reinforced waterproof plaster layer between thermal and finish layers. The purpose of this layer is, because of its physical, mechanical, hydraulic and durability properties, to be used against the weathering.

Regarding finish layer, there are not only ceramic tiles but also, as we can see in the picture above, in the bottom of façade we can see plaster finish layer.

In the case of plaster finish layer, the material has rustic finishing. It is understood that this material is resistant to weathering as well as ceramic tiles.

NOTE:

As we can see in the following graphic details of each type of facade, for the inner coating is used plaster in the three cases. It will be done during the works of the inner walls.

In the other hand, it is important to highlight that in the dual wall we have the existing masonry wall instead of outer coating. Additionally, in the bottom of the dual wall, between both layers of thermal insulation, it is important to use a drainage mesh against the moisture from the foundation.

Other important step in the dual wall is cleaning the neighbour wall before starting our works in order to get the suitable conditions to prevent future pathologies. We must to spread a thin projected polyurethane layer.

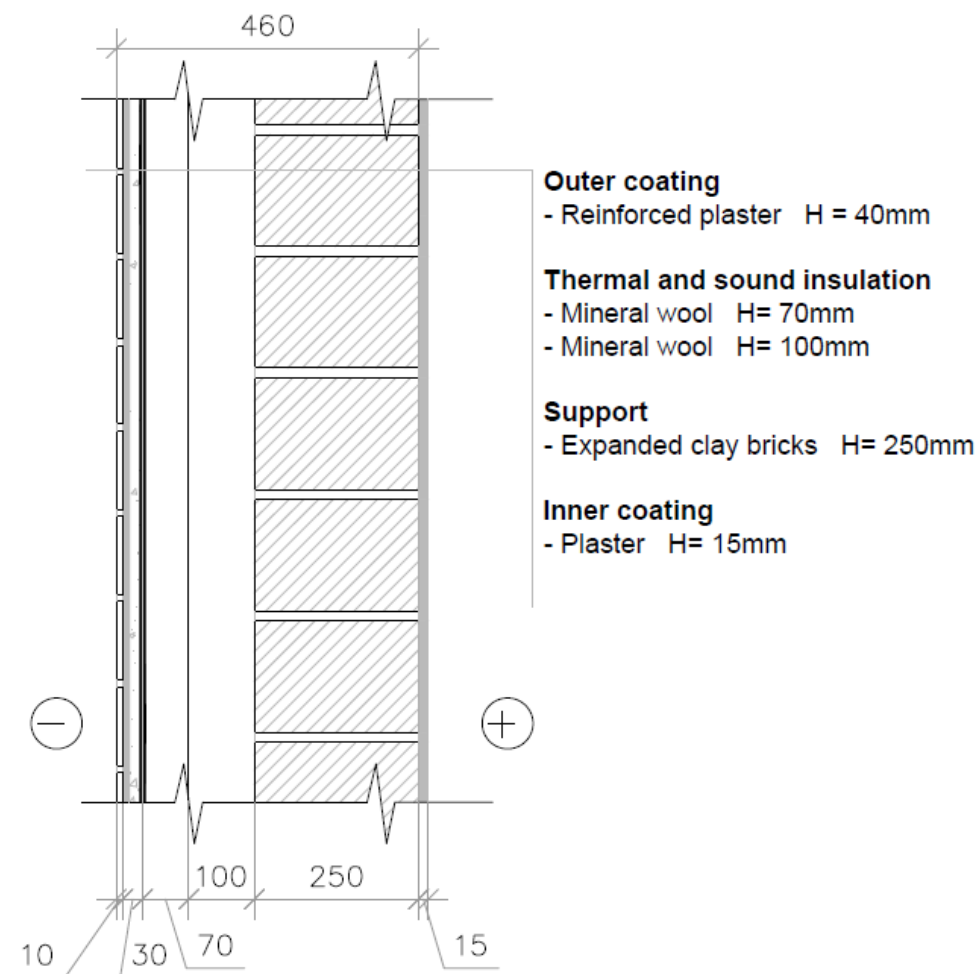

Figure 7. Detail of ceramic tiles finishing

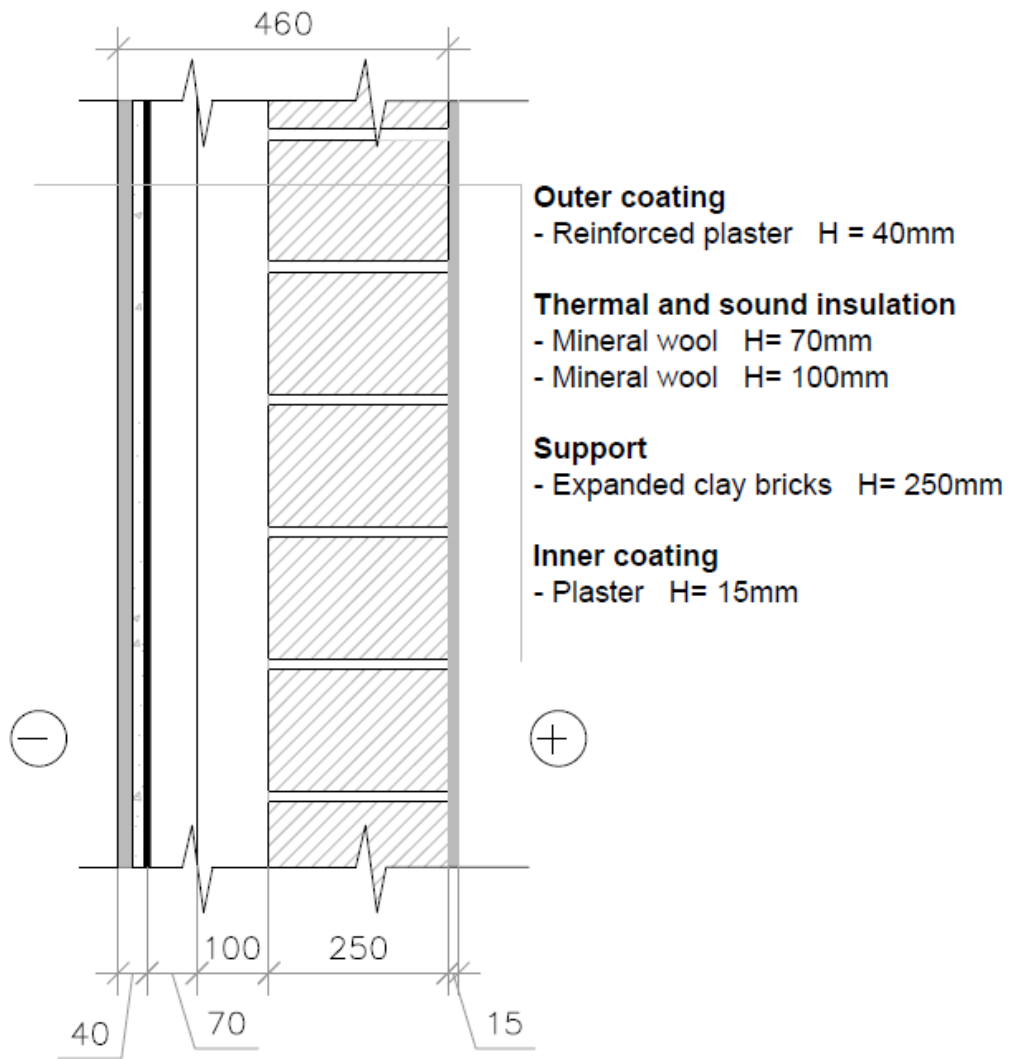

Figure 8. Detail of plaster finishing

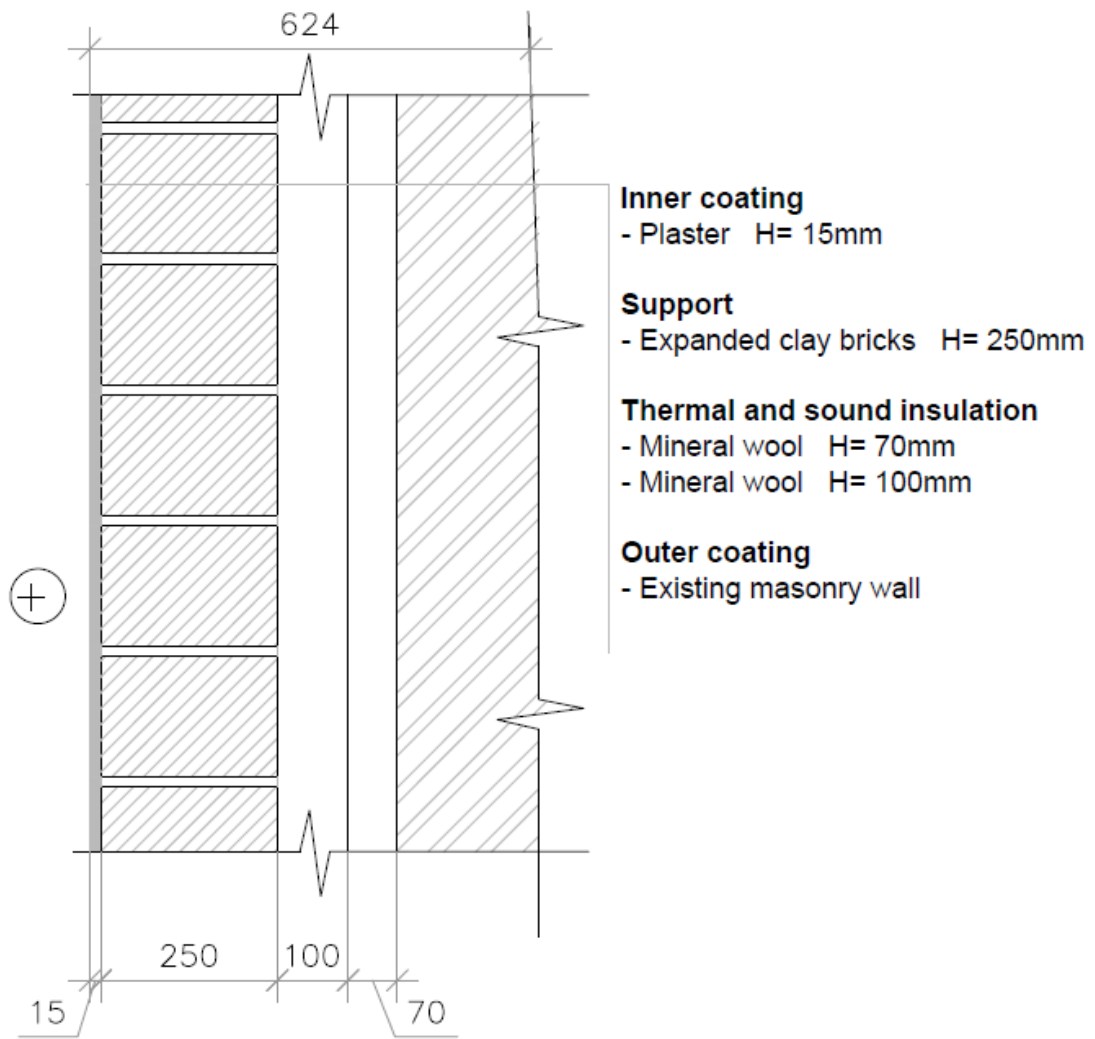

Figure 9. Detail of dual wall

During the Final Thesis works, we had the opportunity to take some pictures of the building works.



Figure 10. Bottom of party wall

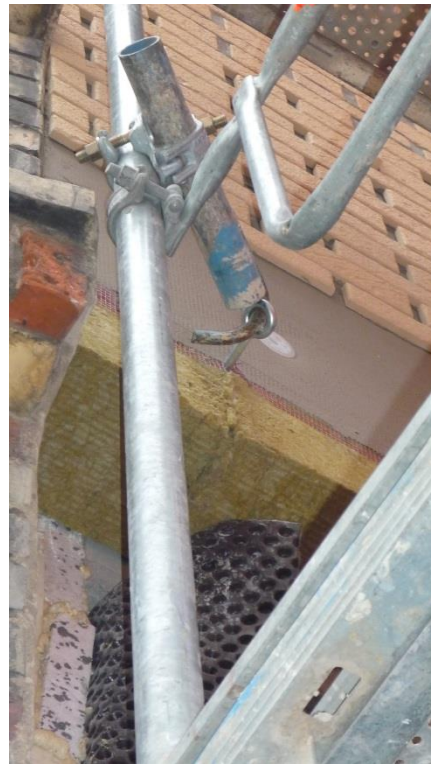

Figure 11. Different layers of facade

2.1.3 LOCATION OF THE DIFFERENT TYPES OF FACADE

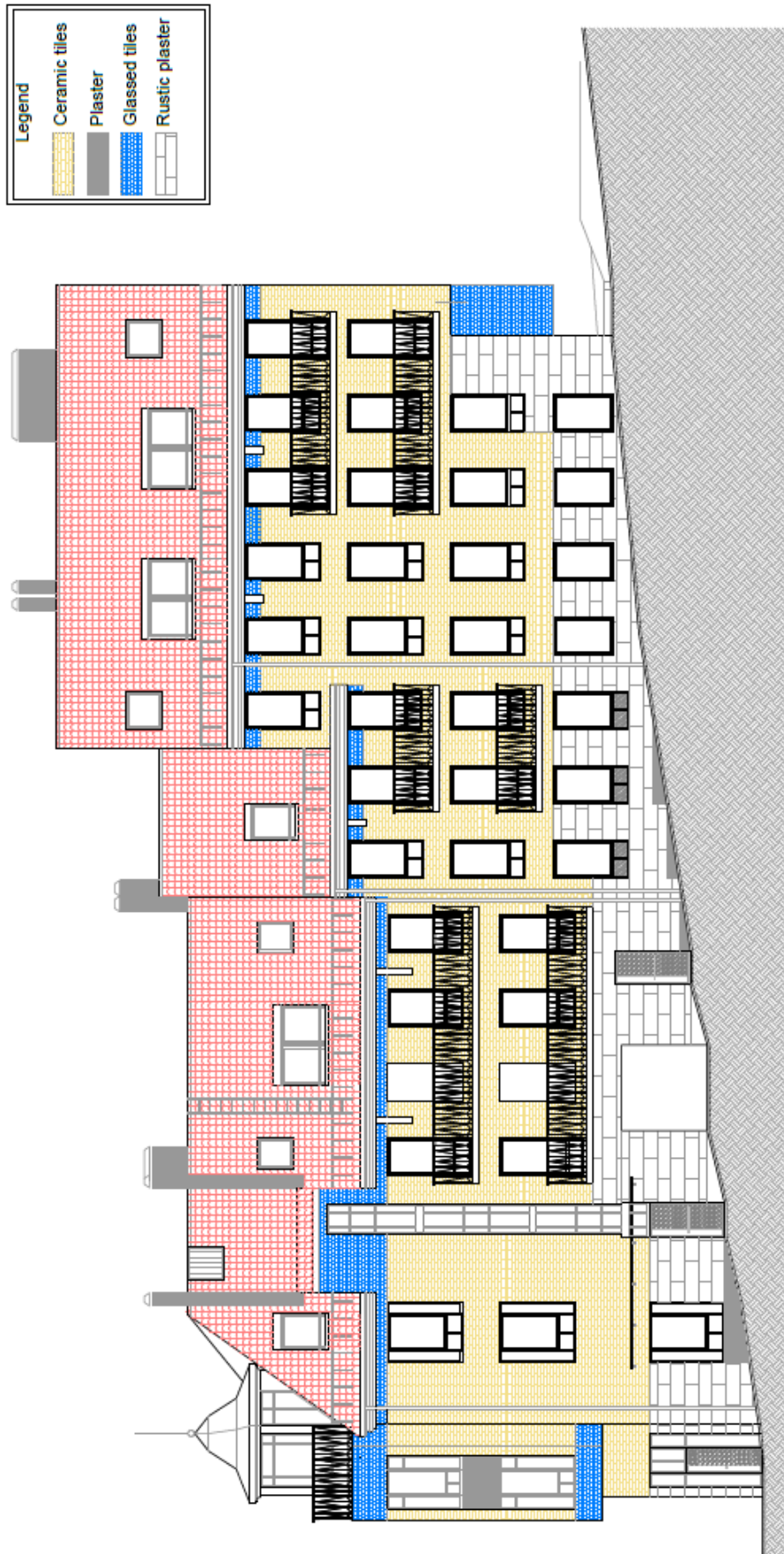

Figure 12. Unnamed alley facade



Figure 23. Top view of second floor

- First phase of execution
- Second phase of execution
- Third phase of execution

2.1.4 HUMAN SAFETY

In this part we are going to talk about the risk of the façade works.

The activities developed during façade works are: stakeout and execution of bricks layer, plaster of inner of façade, thermal and sound insulation with mineral wool and outer coating. Including assembly and disassembly of tubular metal scaffold.

Firstly it is explained the main risks which workers are exposed, and after that it is explained the preventive measures that we can use to decrease the risk.

To build the façade there are two parts, the first one, the built of bricks layer, can be executed from the slab, and the second part (the execution of thermal layer, reinforced layer and finish layer) is done using a tubular metal scaffold.

Then I will list all risk:

- Persons falling at same level
- Persons falling at different level.
- Objects falling on persons
- Bumping into objects
- Hurts by handling objects and hand tools.
- Dermatitis because of contact with cement
- Particles in the eyes
- Cuts by using machinery
- Overexertion

To prevent the risks above, the workers must to keep the following measures:

- Workers are allowed to work only with the knowledge of safety and health rules. The rules must be provided for the responsible person.
- Use of vertical safety nets type “u” along the façade during works from the slab.
- Use the necessary protections to cover the holes. (It must be placed since structure process)
- Stairs must be protected in their perimeter by solid railing. It will be 1m height, with handrail, intermediate slat and lower skirting board.
- Work areas provided of necessary light in case of lack of natural illumination.
- Keep clean the work area.
- For provide the work area with materials, it is used the crane and platforms of loading and unloading in each floor. During these works, the workers will use a safety harness attached to a safety point.

- The workers must use correctly materials and work equipment. Such materials as work equipment must be provided of the correct use rules in order to achieve the required performance and quality.
- Each worker must use individual protective equipment (helmet, boots, gloves, special clothing, safety belt and in some cases, respiratory masks).
- Area provided the containers for each type of waste according to safety data sheets of the products.

2.1.4 QUALITY CONTROL

During façade works it is important to control not only the executed process but material as well.

The control starts checking if the specific characteristics of materials required in the architectural project are the same as suppliers brings to the work.

This technical reception is realized to ask and check the solicitude of quality marks, test and other more characteristics solicited.

It is important to highlight the CE mark of the materials.

Before start the works it is necessary to ready the machinery and tools that will be useful for good developing of process (to cut some pieces, to fix it) and also the tools used during stakeout the façade.

The first point to check is the stakeout. It is good practice to do it with bricks.

After stakeout it starts to build up the façade. Worth noting that the mortar used must be waterproof.

It is important that all of joints between bricks are full of mortar in order to achieve sealing against the water or cold inside the building.

To build the external leaf is necessary using scaffold. It will be placed along the whole façade during the execution of works.

A singular point that it is important to paid attention is the execution of the holes for windows. It must be watertight.

After bricks layer is executed the thermal insulation layer.

When the façade is finished, is required to make the waterproof test.

All materials will be provided by the supplier with characteristic data sheet attached.

The materials will be stored in a conditioned place without contact with prejudicial substances.

The bricks will be provided of certificate of previous compression test according to UNE EN 1052-1:1999, traction and cutting according to UNE EN 1052-4:2001.

As to tolerances of vertical walls, the CTE law downs the following ranges:

To collapse:

- Height of floor: 20mm
- Total height of building: 50mm

To axiality:

- 20mm

To flatness:

- Along 1m : 20mm
- Along 10m: 50mm

To thickness:

- ±25mm

After mixing the mortar it is forbidden to add binders, aggregates, additives or water.

2.1.6 ORGANIZATION OF WORKS OF FAÇADE

In order to achieve the works before the deadline, it is necessary to make a previous program, it consists in mixing not only one factor but different resources as materials as persons.

The execution of façade is done by a 2 workers team that will build the expanded clay bricks layer and other team of 2 workers that will build the other layers as thermal insulation and coating layer.

Facade runs in phases. First phase is Vingriu Street facade and half of unnamed alley façade. Second phase is the rest of unnamed alley and following two facades, finally the courtyard facades.

As we noted earlier, we are going to focus the calculations on the type of façade which coating is ceramic tiles. Total area of this type of façade is 1318,16 m².

Calculations are made assuming a total of 20 working days per month with 8 hours per day.

To reckon an estimated duration of works we use the performance from data base of CYPE and IVE.

By this equation it is obtained the duration of work:

$$D = \frac{\text{Measuring (m}^2\text{)} \times \text{Performance } (\frac{h}{m^2})}{\text{No. hours} \times \text{No. workers}}$$

Following I am going to list all the activities developing during the façade construction process.

- Expanded clay bricks
- Scaffold assembly
- Thermal insulation
- Ceramic tiles with reinforced plaster

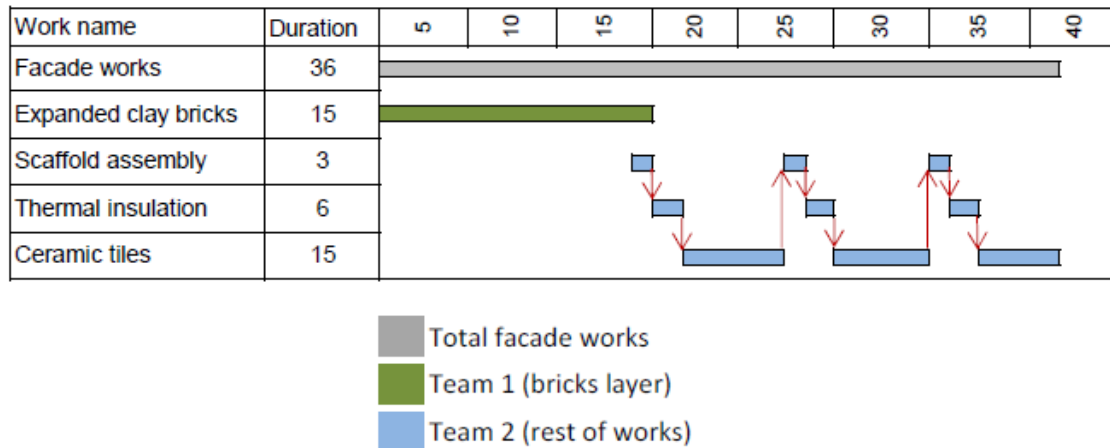

Table 2. Schedule of facade works

2.1.6 MATERIAL AND TECHNICAL RESOURCES OF ALL FACADE WORKS

This section is a list to quantify the workforce and the materials as well as tools and machinery used to perform the construction works.

NAME	UNITS	QUANTITY
Workers		
Brick layer	pers.	6
Other layers + scaffold	pers.	2
Materials		
Ceramic tiles	m ²	1,318.16
White cement	m ³	39.54
Fiberglass mesh reinforcement	m ²	1,318.16
Mineral wool	m ²	1,318.16
Expanded clay bricks	m ²	1,318.16
Tools nad machinery		
Level	U	2
Hammer	U	2
Shovel	U	6
Trowel	U	6
Pliers	U	3
Scaffold	m ²	1,318.16
Lead	U	6

Table 3. Material and technical resources of facade works

2.1.7 CALCULATION OF THE PRICE FOR FAÇADE WORKS

The prices are got from data base of CYPE.

m²

Facade, expanded clay bricks

U	Decription	Perf.	Unit Price	Total price
u	Expanded clay brick 30x19x24 cm, even w / w of special pieces: half, finishing, corner, base and kick corner kick.	17.850	0.91	16.24
m ³	Mortar cement CEM II / BP 32.5 N type M-10, made in situ with 380 kg / m ³ cement and a volume ratio 1/4.	0.020	126.67	2.53
m	Prestressed girder, T-18, Lmedia = <4 m, according to UNE-EN 15037-1.	0.180	4.61	0.83
u	Expanded clay brick, 30x19x4, 8 cm	1.500	0.44	0.66
h	Official in brick construction.	0.445	17.24	7.67
h	Ordinary worker in brick construction.	0.222	15.92	3.53
%	Auxiliary stuff	3.000	31.46	0.94
%	Indirect costs	3.000	32.40	0.97
Total:		33.37		

U

Tubular scaffold

U	Description	Perf.	Unit Price	Total price
u	Impact, m ² , standard mounting tubular scaffold, multidirectional, maximum 20 m working height, tubular structure consisting of galvanized steel, 48.3 mm in diameter and 3.2 mm thick, manufactured to meet the quality requirements listed in the UNE-EN ISO 9001, UNE-EN 12810 and EN 12811; compound work platforms 60 cm wide, arranged every 2 m high staircase inside flap, rear rail and baseboard with two bars, and front rail with a bar; for execution of building façade elements (balconies, cornices, galleries, etc.); even flexible network monofilament polyethylene 100%.	1,931.166	6.75	13,035.37
u	Impact, m ² , standard disassembling tubular scaffold, multidirectional, maximum 20 m working height, tubular structure consisting of galvanized steel, 48.3 mm in diameter and 3.2 mm, manufactured to meet the quality requirements listed in the UNE-EN ISO 9001, UNE-EN 12810 and EN 12811; compound work platforms 60 cm wide, arranged every 2 m high staircase inside flap, rear rail and baseboard with two bars, and front rail with a bar; for execution of building façade elements (balconies, cornices, galleries, etc.); even flexible network monofilament polyethylene 100%.	1,931.166	4.63	8,941.30
%	Auxiliary stuff	2.000	21,976.67	439.53
%	Indirect costs	3.000	22,416.20	672.49
			Total:	23,088.69

m²

Insulation

u	Description	Rend.	Unit Price	Price starting
u	Mechanical elements for insulation of rock wool panels placed directly on the support surface.	3.000	0.14	0.42
m ²	Panel rigid mineral wool, according to UNE-EN 13162, uncoated, 60 mm thick, thermal resistance 1.7 m ² K / W, thermal conductivity 0.035 W / (mK).	1.050	5.36	5.63
m	Grip tape for sealing joints.	0.440	0.28	0.12
h	Official insulation fitter.	0.120	17.82	2.14
h	Assistant editor of isolates.	0.120	16.13	1.94
%	Auxiliary stuff	2.000	10.25	0.21
%	Indirect costs	3.000	10.46	0.31
Total:		10.77		

m²**Ceramic tiles**

u	Decomposition	Rend.	Unit Price	Price starting
m ³	Mortar cement CEM II / BP 32.5 N type M-5, prepared in situ with 250 kg / m ³ of cement and a volume ratio 1/6.	0.020	109.57	2.19
kg	Improved cement adhesive, C2 TE with reduced slip and extended open time, according to UNE-EN 12004, gray color.	2.000	0.57	1.14
m ²	Ceramic tiles, 23x15x3, 7 cm.	1.050	27.35	28.72
h	Official of ceramic tiling.	0.607	17.82	10.82
h	Assistant of ceramic tiling.	0.607	16.13	9.79
%	Auxiliary stuff	3.000	52.86	1.59
%	Indirect costs	3.000	54.45	1.63
		Total:	55.88	

2.1.8 TECHNICAL – ECONOMIC INDICATORS**QUANTITY OF WORKS:**

1.318,16 m² of facade composed by expanded clay bricks layer, thermal and sound insulation, reinforced plaster layer and ceramic tiles layer. Built from scaffold of 20.00 m high around all of facade.

CONSTRUCTION AND WAGE COSTS:

Expanded clay bricks layer: 33.37 €/m² x 1,318.16 m² = 43,986.99 €

Thermal and sound insulation: 10.77 €/m² x 1,318.16 m² = 14,196.58 €

Ceramic tiles with reinforced mesh: 55.88 €/m² x 1,318.16 m² = 73,922.41 €

Scaffold assembly = 23,088.69 €

TOTAL = 155,194.67 €

DURATION OF THE WORKS:

As we noted earlier the facade is built by different phases with two teams, one for bricks layer and other one for the rest of works. However, each layer can not start until the end of the previous layer. For calculations we take 8 hours per day and 20 work days per month. The total duration of the works is calculated and showed in the following table.

Work name	Unit	Medition	Performance	Nr workers	Hours	Days
Expanded clay bricks	m ²	1,318.160	0.445	6	8	12.220
Scaffold assembly	m	638.460	0.250	6	8	3.325
Thermal and sound insulation	m ²	1,318.160	0.250	6	8	6.865
Ceramic tiles with reinforced mesh	m ²	1,318.160	0.550	6	8	15.104
						37.515
						37
					TOTAL	DAYS

Table 4. Duration of facade works

The total days are calculated by the following equation:

$$D = \frac{\text{Measuring (m}^2\text{)} \times \text{Performance}(\frac{h}{m^2})}{\text{No. hours} \times \text{No. workers}}$$

As it is showed in the table the total duration of the works is 37 work days, however, as we explained in the schedule, the different layers works can be developed at the same time because we count with two teams of workers. This possibility makes shorter the duration of the works. Thereby the total duration of façade works is 36 days. It is the same as 1 work month and 16 work days.

2.2 TECHNOLOGICAL CARD II, FLOORING WORKS

2.2.1 GENERAL DESCRIPTION

The building is composed by different types of flooring. The main classification of floorings is inner flooring and outer flooring; however we can make one more detailed classification.

In the inner flooring we can find: flooring between apartments floors; flooring between apartments and parking floor; flooring between parking floors; flooring between parking and ground floor.

In the other hand, the terrace flooring and courtyard park flooring are the outer floorings. We are going to talk about the process of execution of flooring between inner floors, however we will explain also the different layers of the others types flooring.

As we explained in the Architectural part, each floor and each apartment has different area, so we will make calculations using the second floor's area. Taking in account the plans the total area of second floor is 686.29 m². The finish layer is not specified in the plans so we consider ceramic tiles as finish layer.

2.2.2 DESCRIPTION OF TECHNOLOGY AND SEQUENCE OF WORKS

The inner floorings are built on the structure, on the slab.

Following it is described all layers used to perform the flooring with graphical information.

Preparation of the base:

Due to the floors are on concrete structure, the first step before start the works is to clean and manage all waste on the surface. It is an important step that must be realized by workers in order to guarantee good adherence between other layers.

In the case of the second underground floor (2n floor of parking place) and also in the courtyard floor, the foundation is not concrete structure but directly ground. Therefore before starting with flooring works it is important to compact the ground.

Leveling sand layer:

This layer is used in order to provide the following layers by a suitable base.

If the support presents a little height differences between some points of the surface, it is solved by this sand layer. Actually this layer is also used for grant the flooring the necessary thickness in case of existing different types of flooring with different thickness.

Usually the minimum thickness of this layer is 20 mm but in our case the thickness of this layer is 50 mm for a correct behavior.

Sound and thermal insulation:

In inner floorings the common type of material is mineral wool.

The structure of mineral wool consists in a mat of fibers which prevents the movement of air and coupled with its long-term stability, gives it the ability to combat noise pollution and promote safety by reducing the risk of fire.

However, in outer floorings the common type of material is extruded polystyrene (EPS).

It is rigid and tough closed-cell foam. It is usually white and made of pre-expanded polystyrene beads. EPS is used for many things packaging, bowls, cups... But the use in which we are interested is the molded sheets for thermal and sound insulation. The good thermal conductivity properties and the low density makes it a good insulation material, it is also cheap, easy to produce and it is used very often in terrace and exterior areas as in our case because it is resistant to moisture.

Inter-layer:

This layer of polyethylene is used for filtration, drainage, reinforcement, separation, stabilization, protection and waterproof barrier. This material is appropriate because of its physical, mechanical, hydraulic and durability properties.

In this case the polyethylene film is placed between rock wool insulation layer and mortar layer. Bearing this in mind, the main use in our case is to separate both layers.

In the case of terrace, we can find a layer of geotextile as drainage. Due to the terrace is directly placed outside of the building, it must be resistant to weathering, to grant these characteristics to the floor this layer makes easier the evacuation of water. Nevertheless, this layer is also used to separate the extruded polystyrene layer and mortar layer.

Additionally, we can find also in the terrace floor, the polyethylene film layer but in this case it is used to separate the thermal insulation layer and the leveling sand placed on the concrete structure.

Leveling layer:

The materials of this layer have different uses at the same time. The first use that we can describe is as levelling layer to perform a levelled surface which is able to offer a suitable support for finish layer.

Another attributed use is to grant the proper thickness to the flooring to get a regular thickness between the different types of flooring.

Finally, taking in mind the reinforcement, this mesh is used to avoid the possible retractions that can affect the final finish and moving in from their place.

Finish coating:

Depend of the rooms and areas, the coatings will be different such as their characteristics. The selected coatings are not availed in the project information, however we choose ceramic tiles as finishing coat on most of the building.

On terrace the finishing coat is stamped concrete. This type of finishing grants to the floor the suitable characteristics of durability and resistance against the weathering.

In the other hand, as courtyard finishing layer we can find "Latexfalt Parkdeck". Latexfalt Parkdeck protects the underlying concrete structure against penetration and erosion by water. The surface to be treated must be thoroughly cleared of loose particles, dirt, dust, oil, grease, old coatings and cement skins. The surface should be moistened first.

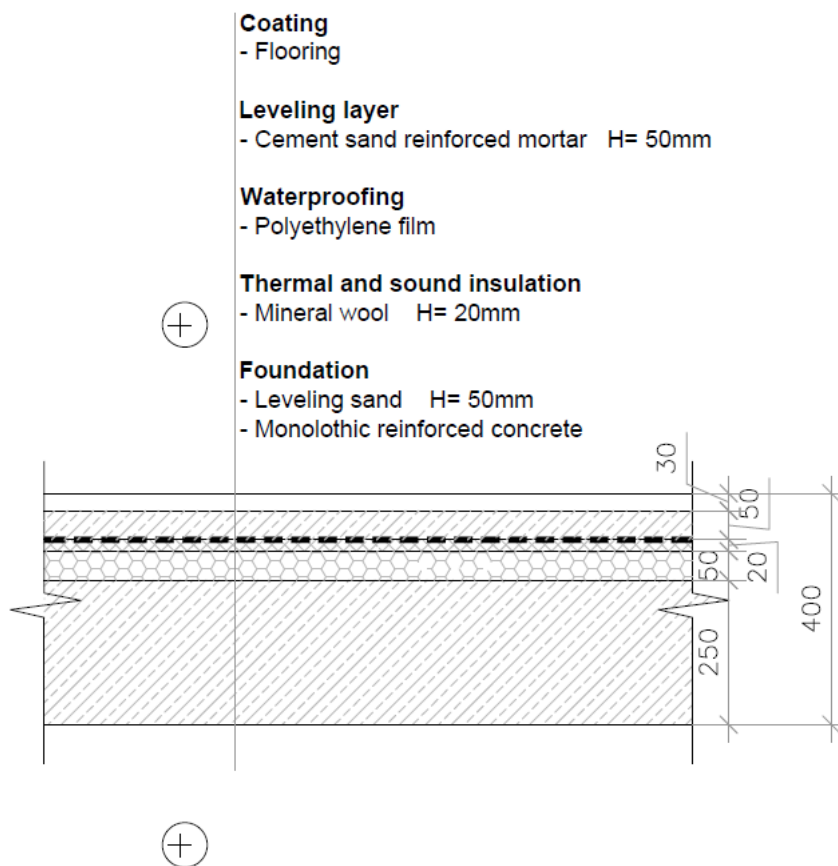

Figure 14. Detail of flooring between apartments floors

In the following case we can find thermal and sound insulation in both sides of the concrete foundation. It is necessary in the floors which divide an habitable area and a non-habitable area.

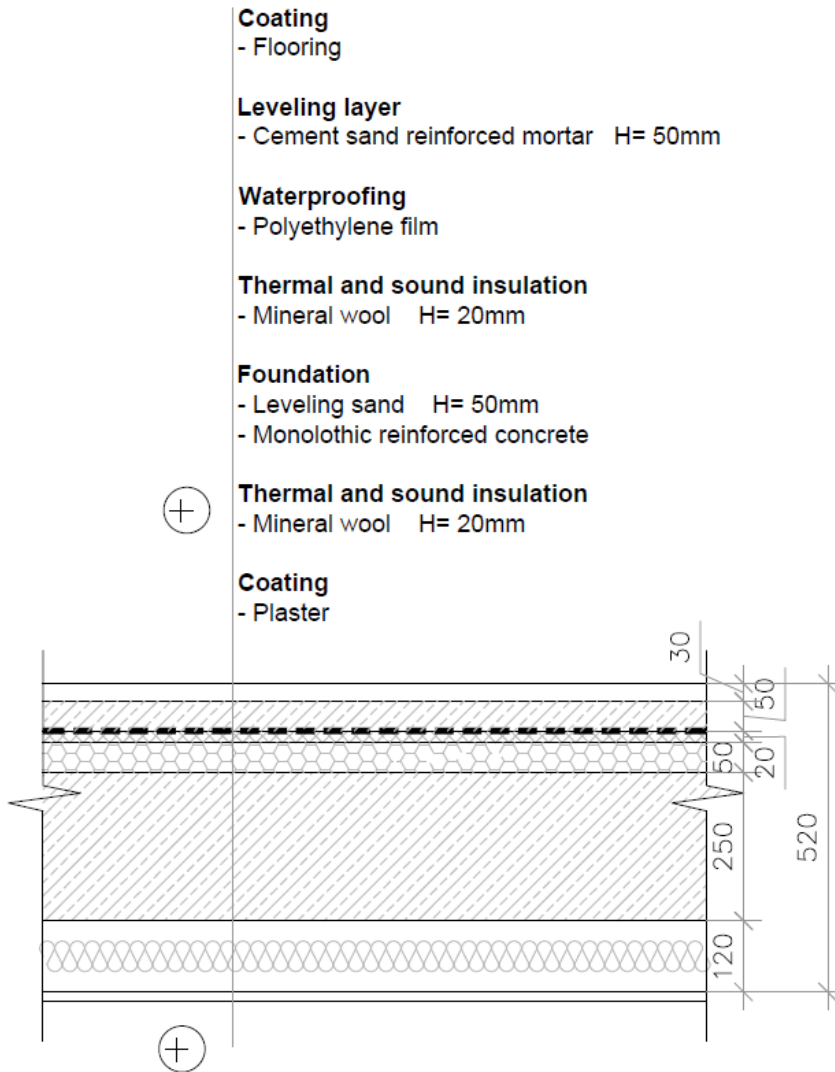

Figure 15. Detail of flooring between ground floor and underground floor

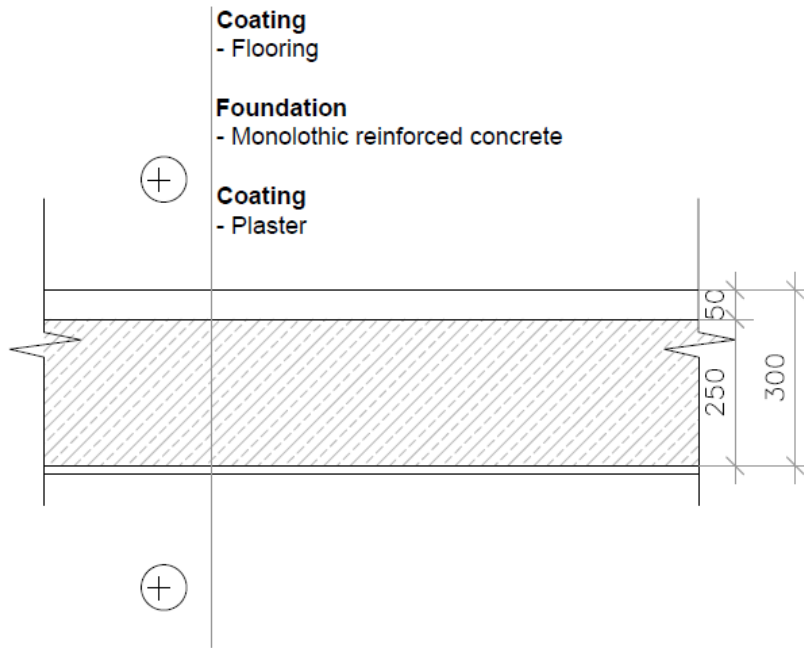

Figure 16. Detail of flooring between parking floors

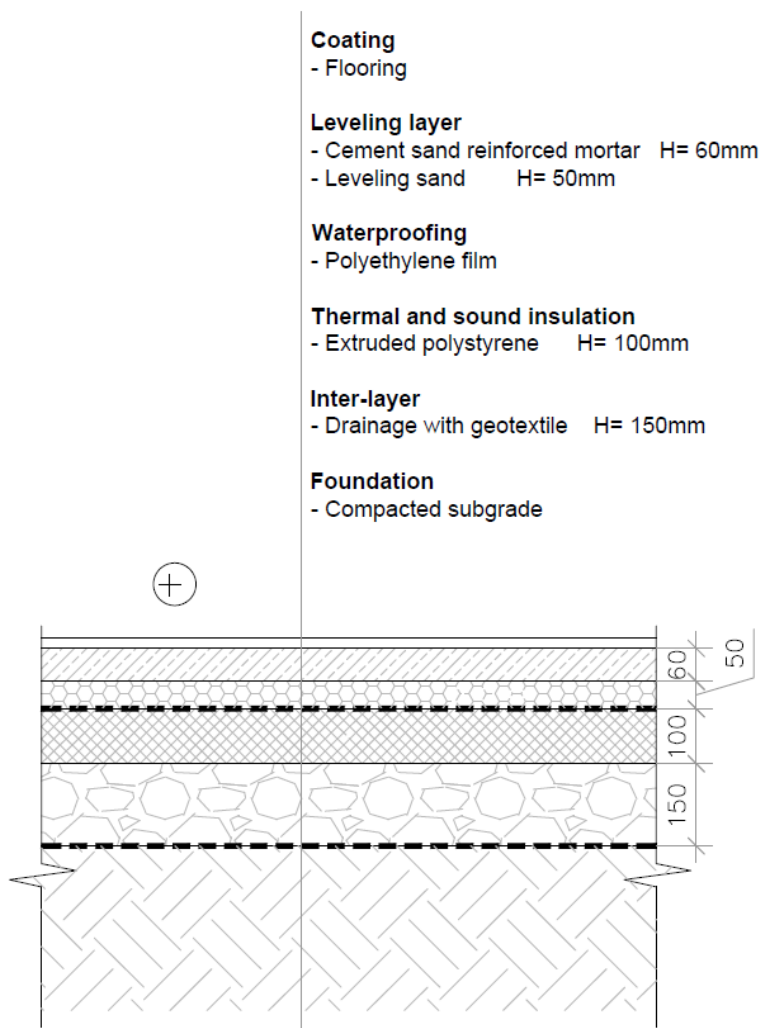

Figure 17. Detail of flooring between parking floor and ground

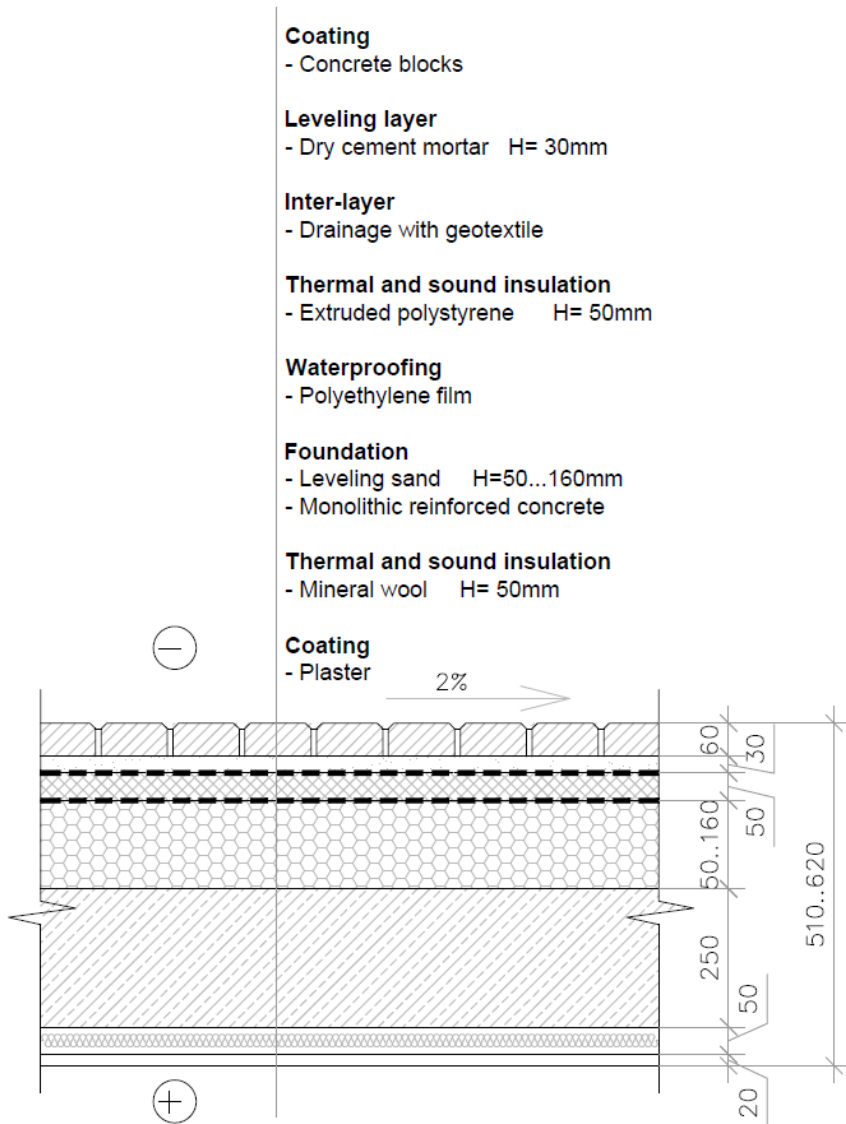

Figure 18. Detail of terrace flooring

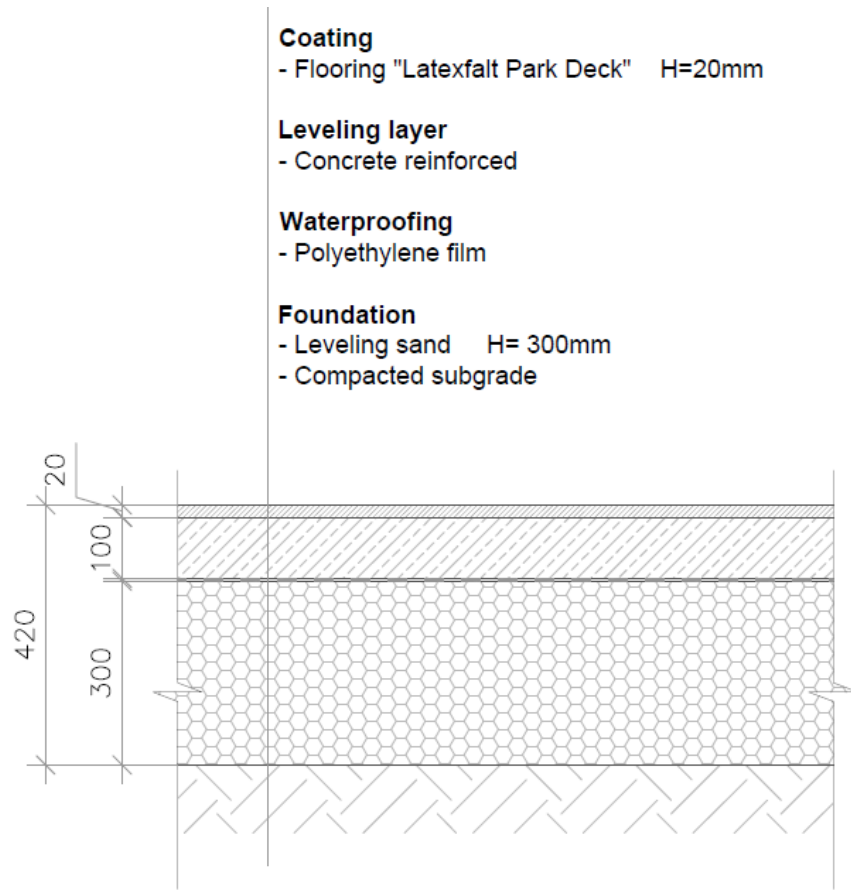

Figure 19. Detail of courtyard flooring

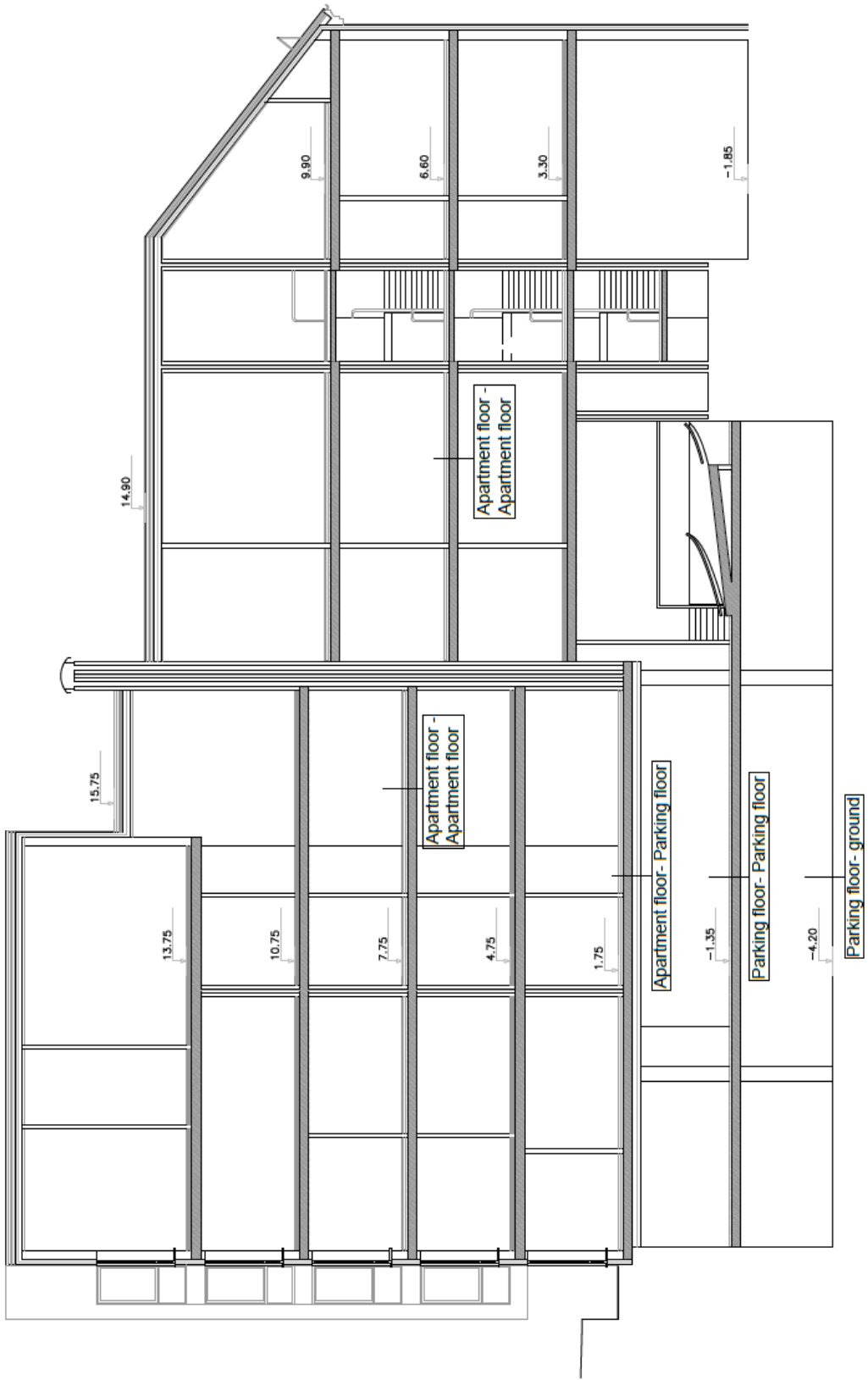

Figure 20. Types of flooring

2.2.3 HUMAN SAFETY

In this part I am going to talk about the risk of the flooring works.

For starting the works it is necessary provide by materials the area of works.

The first step is increase the level by compacted sand layer. When it is finished, we can start with insulation layer. On the insulation we will lay polyethylene film and when the surface is cover by film we can star to spread reinforced mortar. Finally, over this last leveled layer, we can execute the finishing layer. In order to get a perfect finishing, we will use plastic separators between ceramic pieces. After tiles it is necessary to punch by pneumatic hammer the tiles to be sure that it is fixed correctly. Additionally we have to check the leveling and one day later we can spread the grout.

The total surface of works is 686,29 m².

Firstly I will talk about the main risks which workers are exposed, and later about preventive measures that we can use to decrease the risk.

According the areas we can find different risks, but generally the main risks are the following:

- Persons falling at same level
- Objects falling on persons
- Bumping into objects
- Hurts by handling objects and hand tools.
- Dermatitis because of contact with cement
- Particles in the eyes
- Cuts by using machinery
- Overexertion
- Electrocutation
- Inadequate illumination

To prevent the risks above, the workers must to keep the following measures:

- Workers are allowed to work only with the knowledge of safety and health rules. The rules must be provided for the responsible person.
- Work areas provided of necessary light in case of lack of natural illumination. Artificial light will work with less of 24 V, it will be protected by insulated handle. Minimum illumination will be 100 lux placed at 2 m from ground.
- Keep clean the work area. The materials must be in a corner, not in the middle of work area. The tools will be in its place, not on the ground.
- The workers have to change the position during the works, not always in the same position for prevent overexertion.
- For provide the work area with materials, it is used the crane and platforms of loading and unloading in each floor. During these works, the workers will use a safety harness attached to a safety point.

- The workers must use correctly materials and work equipment. Such materials as work equipment must be provided of the correct use rules in order to achieve the required performance and quality.
- Each worker must use individual protective equipment (helmet, boots, gloves, special clothing, safety belt and in some cases, respiratory masks).

Area provided the containers for each type of waste according to safety data sheets of the products.

2.2.4 QUALITY CONTROL

During flooring works it is important to control not only the executed process but material as well.

The control starts checking if the specific characteristics of materials required in the architectural project are the same as suppliers brings to the work.

This technical reception is realized to ask and check the solicitude of quality marks, test and other more characteristics solicited.

It is important to highlight the CE mark of the materials.

Before start the works it is necessary to ready the tools that will be useful for good developing of process (to cut some pieces, to fix it) and also check slab where the flooring will be lay. It should be resistant.

It is important to get a suitable base for lay the ceramic pieces.

The colocation of the pieces will star from center of room to borders. In case of needing half piece, it will be placed in the border not in the middle of room.

Before colocation of the ceramic pieces we should moisten it.

After colocation, in order to fix it, we use a pneumatic hammer. Finally we spread the grout along the floor.

We have to get a continuous surface and flatness.

2.2.5 ORGANIZATION OF WORKS OF FLOORING IN SECOND FLOOR

In this part we are going to analyze the second floor flooring. The type of flooring that we can find in this floor is flooring between apartments floors.

As in the case of façade, in flooring works is also important to achieve the works before the deadline, it is also necessary to make a previous program.

The execution of flooring is done by one team with 2 workers.

Total area of flooring is 686,29 m².

Calculations are made assuming a total of 20 working days per month with 8 hours per day.

To reckon an estimated duration of works we use the performance from data base of CYPE and IVE. However is not necessary to follow always the information provided by these data bases so in some cases we took our decision.

By this equation it is obtained the duration of work:

$$D = \frac{\text{Measuring} \times \text{Performance}}{\text{No. hours} \times \text{No. workers}}$$

Following I am going to list all the activities developing during flooring construction process:

- Levelling sand layer
- Insulation layer
- Reinforced mortar
- Ceramic tile layer

Work name	Duration	1	2	3	4	5	6	7
Flooring works	7							
Leveling sand layer	2							
Insulation layer	1							
Reinforced mortar	1							
Ceramic tiles layer	3							

Table 5. Schedule of flooring works

2.2.6 MATERIAL AND TECHNICAL RESOURCES OF ALL FLOORING WORKS

During the planning of the works is also important knowing the workforce, materials, tools and machinery used to perform the floor for residential and public areas. As we explained above, the surface studied for flooring works is the surface occupied by second floor apartments, it is an amount of 686.290 m².

We can find in the table the number of workers, all teams together; coating team, insulation team and rest of works team.

NAME	UNITS	QUANTITY
Workers		
Workers	pers.	2
Materials		
White grout	m ²	686,29
Ceramic tiles	m ²	686,29
White cement	m ²	686,29
Fiberglass mesh	m ²	686,29
Polyethylene sheet	m ²	686,29
Extruded polystyrene	m ²	686,29
Rock wool	m ²	686,29
Cement	m ²	686,29
Sand	m ²	686,29
Tools and machinery		
Level	U	2,00
Air Hammer	U	2,00
Shovel	U	3,00
Trowel	U	3,00
Pliers	U	3,00
Circular saw	U	1,00
Unloading platform	U	1,00

Table 6. Material and technical resources of flooring works

2.2.7 CALCULATION OF THE PRICE FOR FLOORING WORKS

The prices are got from data base of CYPE.

m ²		Ceramic tiles with cement mortar		
U	Description	Prf..	Unit Price	Total price
m ³	Mortar cement CEM II / BP 32.5 N type M-5, prepared in situ with 250 kg / m ³ of cement and a volume ratio 1/6.	0.030	109.57	3.29
m ²	Ceramic tile glazed 2/2/H/-, 30x30 cm, 8.00 € / m ² , according to UNE-EN 14411.	1.050	8.00	8.40
kg	Cementitious mortar joints with high abrasion and reduced water absorption, CG2, for minimum joint between 1.5 and 3 mm strength, according to UNE-EN 13888.	0.100	0.94	0.09
h	Official	0.275	17.24	4.74
h	Assistant	0.137	16.13	2.21
%	Aux.	2.000	18.73	0.37
%	Indirect costs	3.000	19.10	0.57
		19.67		
		Total:		

m²**Acoustic film**

U	Description	Perf.	Unit Price	Total price
kg	Cementitious adhesive, C2 E with extended open time, according to UNE-EN 12004, for fixing geomembranes, made by special cements, selected aggregates and synthetic resins.	2,000	0.67	1.34
m ²	Flexible sheet of rubber and polyolefin, with both sides coated polyester fiber, 7 mm thick, supplied in rolls of 10 m long and 0.5 m wide, according to UNE-EN ISO 717-2.	1,050	14.46	15.18
m	Perimeter grip band polyethylene foam, 48 mm wide, supplied in rolls of 25 m in length.	0,100	1.43	0.14
m	Geotextile grip tape, 5cm width, supplied in rolls of 50 m in length.	0,100	0.74	0.07
h	Official	0,102	17.82	1.82
h	Assistant	0,102	16.13	1.65
%	Aux.	2,000	20.20	0.40
%	Indirect costs	3,000	20.60	0.62
			Total:	21.22

m²**Cement mortar**

U	Description	Perf.	Unit Price	Total price
kg	Self-leveling cement mortar, 544 Mastertop "BASF Construction Chemical", type CT-C40-F6-AR0, 5 according to UNE-EN 13813, resins, selected aggregates and synthetic fibers, regularization and interior leveling concrete floors.	70,000	1.37	95.90
l	Synthetic resins modified primer, 404 Gisoground PCI "Chemical BASF Construction", for leveling adhesion of cementitious mortars, asphalt or ceramic substrates.	0,150	9.98	1.50
m ²	Rigid expanded polystyrene panel, according to UNE-EN 13163, machining straight side, 10 mm thick, thermal resistance 0.25 m ² K / W, thermal conductivity 0.036 W / (mK) for expansion gap.	0,100	0.87	0.09
h	Official	0,051	17.24	0.88
h	Assistant	0,051	16.13	0.82
%	Aux.	2,000	99.71	1.99
%	Indirect costs	3,000	101.70	3.05
Total:		104.75		

m²**Base aggregate.**

U	Description	Perf.	Unit Price	Total price
m ³	Selected sand, from 0 to 5 mm in diameter.	0,020	22.41	0.45
h	Assitant ordinary construction.	0,051	15.92	0.81
%	Aux.	2,000	1.26	0.03
%	Indirect costs	3,000	1.29	0.04
Total:		1.33		

2.2.8 TECHNICAL – ECONOMIC INDICATORS

QUANTITY OF WORKS:

686.290 m² of flooring composed by ceramic tiles, reinforced plaster, thermal and sound insulation and sand leveling layer.

CONSTRUCTION AND WAGE COSTS:

Ceramic tiles finish layer: 19.67 €/m² x 686.290 m² = 11,440.4543 €

Reinforced plaster: 104.75 €/m² x 686.290 m² = 71,888.8775 €

Thermal and sound insulation: 21.22 €/m² x 686.290 m² = 14,563.0738 €

Sand levelling layer: 1.33 €/m² x 686.290 m² = 912.7657 €

TOTAL = 98,805.1713 €

DURATION OF THE WORKS:

As we explained above in the schedule, where we took in account that the different works in different floor layers can go on at the same time and also the existence of different teams of workers for build the different parts of floor, the total duration of the works is calculated and showed in the following table.

Work name	Unit	Medition	Performance	Nr workers	Hours	Days
Leveling sand layer	m ²	686,290	0,055	2	8	2,4
Insulation layer	m ²	686,290	0,043	2	8	1,8
Reinforced mortar	m ²	686,290	0,03	2	8	1,3
Ceramic tiles layer	m ²	686,290	0,070	2	8	3,0
TOTAL						7 DAYS

Table 7. Duration of flooring works

The total days are calculated by the following equation:

$$D = \frac{\text{Measuring (m}^2\text{)} \times \text{Performance}(\frac{h}{m^2})}{\text{No. hours} \times \text{No. workers}}$$

As it is showed in the table the total duration of the works is 7 work days. It is the same as 1 work week and 2 work days.

2.3 TECHNOLOGICAL CARD III, ROOF WORKS

2.3.1 GENERAL DESCRIPTION

The objective of this technological card is studying the system of pitched roof as the materials used. In our case the design of the building's roof is gable roof.

Along the roof there are some peculiar points which are interesting to study.

It is used this kind of roof because the last floor is used like attic. In this case we need a warm roof where insulation is inserted between the roof rafters so that the roof space can be heated and get a suitable temperature.

As we noted later, the finish external layer is ceramic tiles thereby achieving a good combination with other enclosure of this city area.

It is important to highlight the different slopes in each side of roof for calculate the area. According the plans, in order to get a better use of space inside the building, the slope can be 31%, 45%, 52% and 68% it depends on the area of roof. As well as the visual appearance, the choice of roof pitch is influenced by the materials to be used and the resulting overlap required if roof tiles are used. In areas of high snowfall then the roof pitch can be much greater, to allow the snow to fall off the roof rather than settle and build up on the roof.

Taking in account the plans and the slopes of roof, the total area to cover is 978.74 m².

2.3.2 DESCRIPTION OF TECHNOLOGY AND SEQUENCE OF WORKS

The structure system of roof for laying the different layers are built by wooden elements. The structure is the traditional system of rafters.

Preparation of the base and setting-up the framework:

To start the works on the concrete structure it is convenient to clean the surface.

After cleaning it is important to make the stakeout of the rafters in order to know the exact position of it and make it as exactly as possible. Also we have to layout the cuts in the rafters for nail it to the slab.

After stakeout, we can start to build the framework. The major part of gable-roof construction is setting the rafters in place. The most efficient method is to pre-cut all common rafters, then fasten them to the ridgeboard and the slab in one continuous operation.

The bottoms of the rafters rest on the slab. The rafters are not framed into the slab, but are simply nailed to it.

Some of them are cut to fit the slab, whereas others, in hasty construction, are merely laid on top of the slab and nailed in place. Rafters usually extend a short distance beyond the wall to form the eaves and protect the sides of the building.

Rafters extend from the slab to the ridge board. In the ridge board the rafters are laid in the metallic beam.



Figure 21. Roof structure system

Rafters are cut in three basic ways:

1. The top cut, is made at the end of the rafter to be placed against the ridgeboard. The width of the cut is determined by the slope of the roof: the lower the slope, the wider the cut.
2. The bottom or seat cut is made at the end of the rafter that is to rest on the slab.
3. Finally, a side cut is a bevel cut on the side of a rafter to make it fit against another frame member.

Gable roof rafters are often reinforced by horizontal members called collar ties. In our case, finished attic, the collar ties function as ceiling joists.

In our building we can also find the framing of a shed in the dormer.

Vapor barrier:

Due to the roof is the part of the building most exposed to weathering; it is necessary a layer for keep the roof against thermal changes.

To get it, we use the vapor barrier which technical characteristics prevent condensation and moisture inside the building.

Insulation layer:

As we mentioned above the roof should be weathering resistant. For grant the building of habitability conditions, we have to use a huge thermal insulation layer. In this case we have three layers of thermal insulation.

Firstly we can find one insulation layer in the inner it is with 50 mm of thickness. After this layer is placed the vapor barrier. Then two more layers of thermal insulation are placed, one of 150 mm of thickness and other one of 30 mm.

It is important don't make mistake during the checking of the thickness of the insulation for provide the building with the suitables habitability conditions.

The material used is mineral wall.

The structure of mineral wool consists in a mat of fibres which prevents the movement of air and coupled with its long-term stability, gives it the ability to combat noise pollution and promote safety by reducing the risk of fire.

Wind and water insulation:

Talking about weathering the most important factor is the temperature, but in the top part of the building it is also important taking in mind the effect of the wind. In order to protect the building against wind and moisture coming from the outside we use wind insulation foil.

This layer, protects the thermal wall insulation from the outside against precipitation and uncontrolled air flows, significantly decreasing the heat loss of the building. It also protects the thermal insulation from loss of fibers and dusting, prevents cooling of the building maintaining its high heat characteristics, low inflammability, stabilized against UV radiation.

Finish coating:

The finishing layer is composed by ceramic tiles.

Tiles have retaining nibs on the back of the tile which rest on the wooden lath. However, due to the steep slopes it is necessary to fix the ceramic tiles with cement mortar.

To ensure a watertight ridge, in the roof ridge we use a ridge tile to cover the gap. The joints between each of the ridge tiles are filled with mortar.

In the verge it is used a special tile to keep it against the wind and raining.

Other point where we have to pay attention is in the funnel where the tiles will be into the bricks and covered by waterproofing mortar.

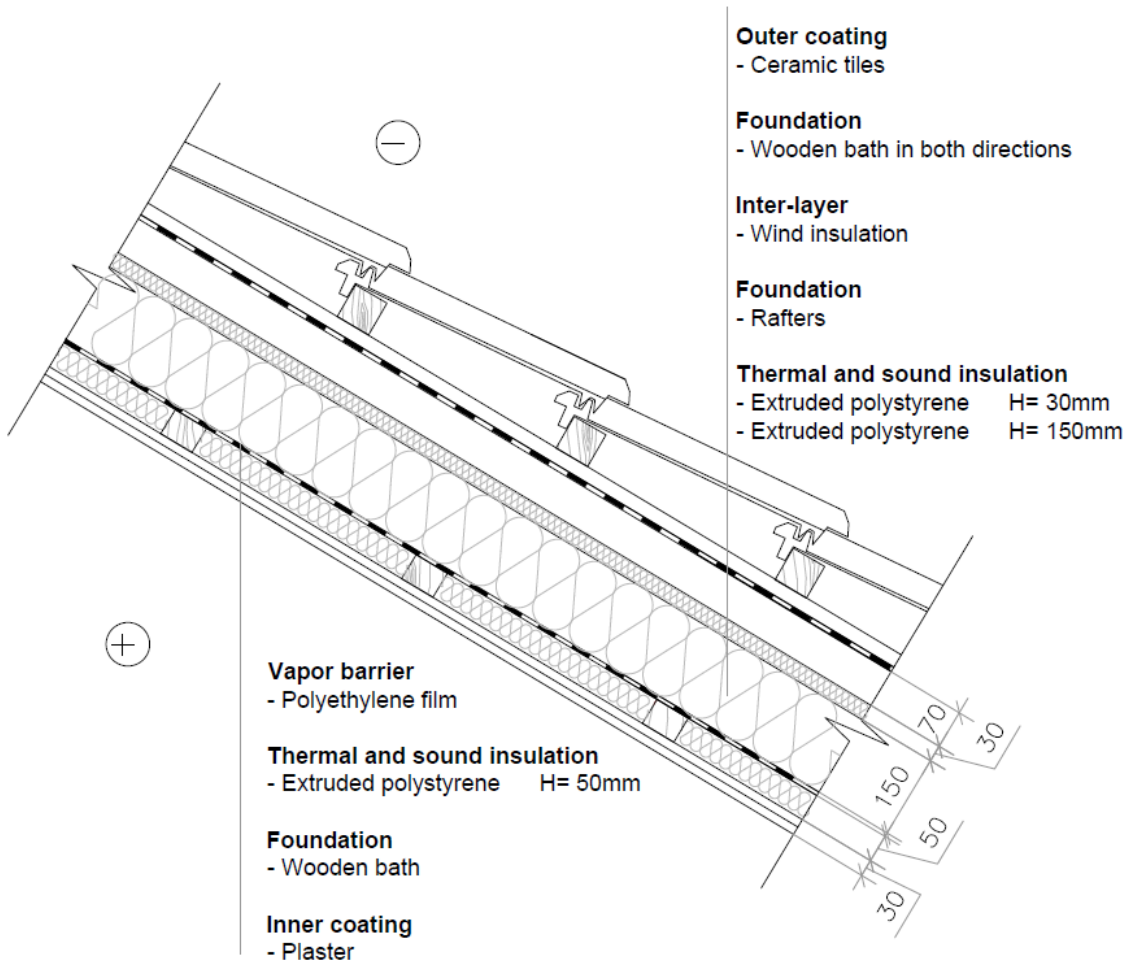

Figure 22. Detail of roof

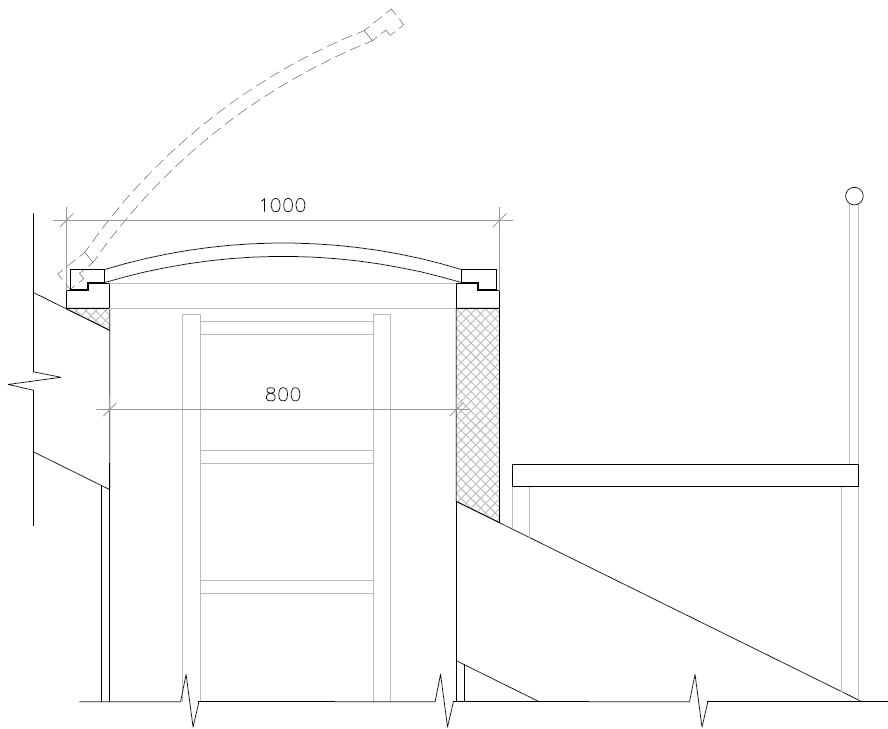

Figure 23. Skylight cross section

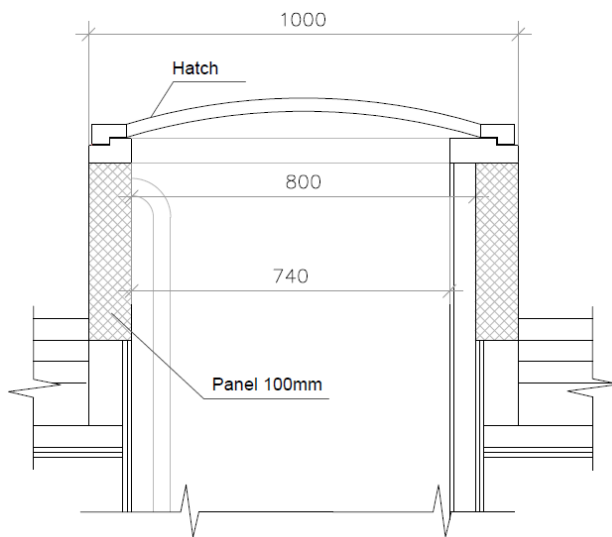

Figure 24. Skylight longitudinal section

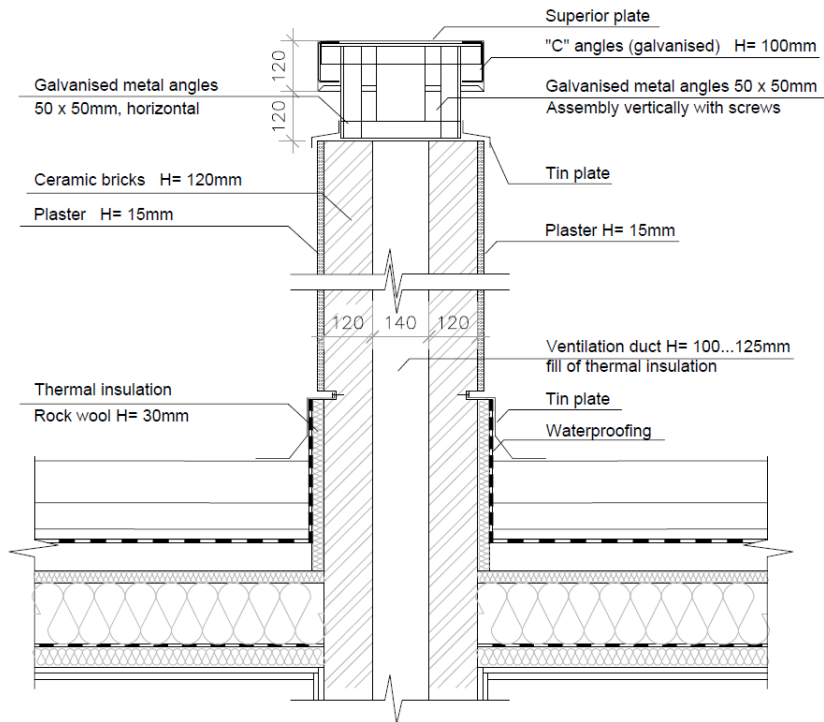

Figure 25. Ventilation duct longitudinal section

2.3.3 LOCATION OF TERRACE AND VENTILATION DUCT

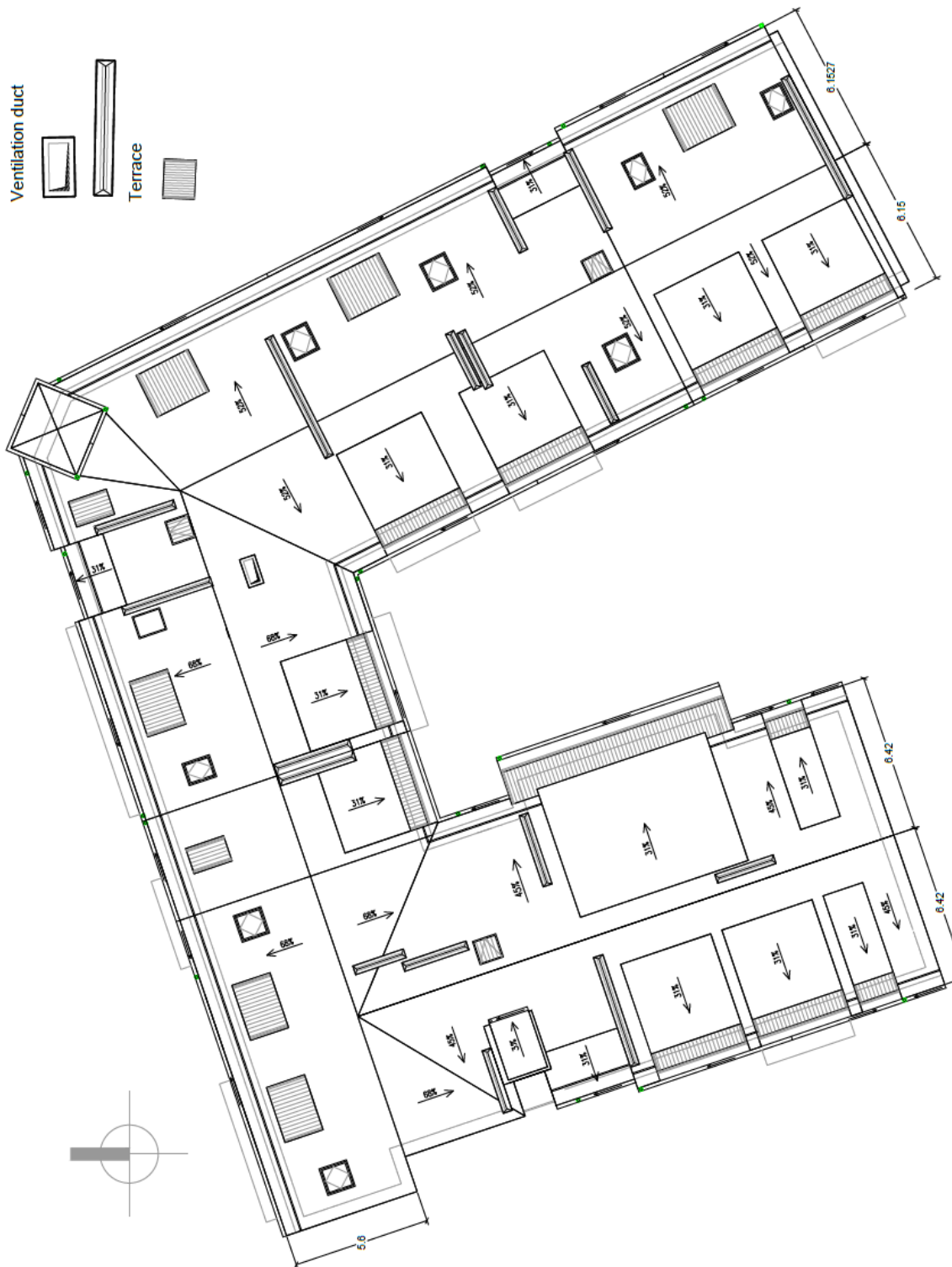

Figure 26. Top view of roof

2.3.4 HUMAN SAFETY

In this part we are going to talk about the risk of the roof works.

The activities developed during roof works are: stakeout and execution of framework, insulation layer in both sides with vapor barrier in the middle and finally the coating layer by ceramic tiles. Additionally, during these works are taking in account the works of ridge, eaves and special points of the deck.

All works are made from last slab, only in some cases is necessary to assembly a scaffold on the last slab.

Firstly I will talk about the main risks which workers are exposed, and later about preventive measures that we can use to decrease the risk.

Due to the roof is the highest part of the building, even in the cases when is not necessary special scaffold, the works are very dangerous.

Then we will list all risk:

- Persons falling to vacuum.
- Persons falling at same level
- Persons falling at different level.
- Objects falling on persons
- Bumping into objects
- Hurts by handling objects and hand tools.
- Particles in the eyes
- Cuts by using machinery
- Overexertion
- Sinking of the work surface

To prevent the risks above, the workers must to keep the following measures:

- Workers are allowed to work only with the knowledge of safety and health rules. The rules must be provided for the responsible person.
- Perimeter railings like 1m height, with handrail, intermediate slat and lower skirting board.
- All holes will remain covered with wood elements nailed into the slab. (It must be placed since structure process).
- Work areas provided of necessary light in case of lack of natural illumination.
- Keep clean the work area. Free movement paths.
- The wind insulation rolls will be gathered uniformly along the slab, avoiding overloading,fixing it in order to avoid rolling and sorting it according work areas.
- For provide the work area with materials, it is used the crane.

- The workers must use correctly materials and work equipment. Such materials as work equipment must be provided of the correct use rules in order to achieve the required performance and quality.
- Each worker must use individual protective equipment (helmet, boots, gloves, special clothing, safety belt and in some cases, respiratory masks).
- Area provided the containers for each type of waste according to safety data sheets of the products.

2.3.5 QUALITY CONTROL

During roof works it is important to control not only the executed process but material as well.

The control starts checking the slab which support all the roof structure. Due to it is concrete structure it should get the suitable resistance required in the project.

Due to the roof is not only a cover against the weathering but also a structural element which support its own weight and loads of snow, wind and raining, it is time to check specific characteristics of materials. Characteristics of materials required in the architectural project must be the same as suppliers brings to the work.

This technical reception is realized in order to ask and check the solicitude of quality marks, test and other more characteristics solicited sometimes by standars.

It is important to highlight the CE mark of the materials as quality mark.

Before start the works it is necessary to ready the machinery and tools that will be useful for good developing of process and also the tools used during stakeout of roof.

Then we can start with the stakeout. It is very important to be exact with the position of rafters because it will be the structure which support the roof. It also defines the height of the gable roof.

Thermal and acustic insulation must be placed between rafters.

Due to the slope of the roof is important to use mortar for prevent the movement of tiles. In this case before put in contact tiles with mortar, we must to wet the tiles in order to keep the water of mortar.

Special point must be made by special tiles to solve the weakness of these points. Also in these special points, we must to take care about joints, it must be watertight.

In order to avoid the entrance of water the last row of tiles must be adhered by waterproof mortar.

After mixing the mortar it is forbidden to add binders, aggregates, additives or water.

2.3.7 MATERIAL AND TECHNICAL RESOURCES OF ALL ROOF WORKS

This section is a list to quantify the workforce and the materials as well as tools and machinery used to perform the construction works.

NAME	UNITS	QUANTITY
Workers		
Workers	pers.	6
Materials		
Ceramic tiles	m ²	978.74
Wooden rafters	m	1,406.426
Mineral wool	m ²	978.74
Wind and water insulation	m ²	978.74
Tools and machinery		
Level	U	1
Hammer	U	1
Shovel	U	1
Trowel	U	1
Pliers	U	1
Lead	U	1
Square	U	1
Crane	U	1

Table 9. Material and technical resources of roof works

2.3.8 CALCULATION OF THE PRICE FOR ROOF WORKS

The prices are got from data base of CYPE.

m² Insulation

U	Description	Perf.	Unit Price	Total price
m ²	Sandwich panel cover comprising: outer face chipboard 19mm waterproof, insulating foam core of extruded polystyrene 40 mm thick fibreboard tab for assembly of inner side panels and waterproof chipboard 10 mm.	1.050	24.38	25.60
u	Oxidizable sandwich panels for fixing wood pitched roof support, larger diameter 6.3 mm self-drilling screw.	5.000	0.08	0.40
m	Self-adhesive waterproof membrane for waterproofing joints between wooden sandwich panels on sloping roofs.	1.000	0.48	0.48
h	Official	0.126	17.82	2.25
h	Assistant	0.126	16.13	2.03
%	Aux.	2.000	30.76	0.62
%	Indirect costs	3.000	31.38	0.94
			Total:	32.32

u Lightweight truss.

U	Description	Perf.	Unit Price	Total price
u	Light truss built with small pieces of squareness (about 4x14 cm) and unions by metals; of sawn wood of Scots pine (<i>Pinus sylvestris</i> L.), brushed finish for a light 6 m and 45% slope, structural quality ME-1 UNE 56544, strength class C-27 to EN 338 and UNE-EN 1912, protection against biotic agents corresponding to the kind of penetration NP2 (3 mm in the lateral faces of sapwood and 40 mm in the axial direction) to EN 351-1.	1.000	64.41	64.41
kg	Steel elements Fe / Zn 12c protection against corrosion, for assembling wooden structures	30.000	3.66	109.80
h	Official	6.966	18.10	126.08
h	Assistant	5.752	16.94	97.44
%	Aux.	2.000	397.73	7.95
%	Indirect costs	3.000	405.68	12.17
Total:		417.85		

m²

Ceramic tiles .

U	Description	Perf.	Unit Price	Total price
m ²	Wooden board Scots pine (Pinus sylvestris L.), edged edges of 22 mm thick, with proper treatment, use class 2 according to UNE-EN 335.	1.050	14.42	15.14
kg	Steel nails.	0.150	1.15	0.17
m	Galvanized batten for fixing tiles.	3.000	1.38	4.14
u	Screw clamp batten.	6.000	0.26	1.56
u	Ceramic tile curve, 40x19x16 cm, red color, according to UNE-EN 1304.	31.400	0.25	7.85
u	Ceramic tile ventilation curve, red color, according to UNE-EN 1304.	0.100	6.50	0.65
h	1st Official editor.	0.981	17.82	17.48
h	Assistant editor.	0.981	16.13	15.82
%	Aux.	2.000	62.81	1.26
%	Indirect costs	3.000	64.07	1.92
Total:		65.99		

2.3.9 TECHNICAL – ECONOMIC INDICATORS

QUANTITY OF WORKS:

978.74 m² of roof composed by ceramic tiles, thermal and sound insulation, wind insulation and the suitable framework like base. Some parts of roof built from scaffold of 2.00 m high.

CONSTRUCTION AND WAGE COSTS:

Scaffold assembly: 1.803,29 €

Framework: 417.85 €/m x 1.406,426 m = 587,675.1041 €

Thermal and sound insulation: 32,32 €/m² x 978,74 m² x 3 layers = 31.632,88 €

Ceramic tiles = 65,99 €/m² x 978,74 m² = 64.587,05 €

TOTAL = 685,698.3241 €

DURATION OF THE WORKS:

As we noted earlier, the different works of roof can not be developed at the same time because all of them are connected. It is necessary have done the framework to start

with wind insulation and the same with the following works. In consequence, the total duration of the works is 51 work days as it is showed in the following table.

The total days are calculated by the following equation:

$$D = \frac{\text{Measuring (m}^2 \times \text{Performance}(\frac{h}{m^2}))}{\text{No. hours} \times \text{No. workers}}$$

Work name	Unit	Medition	Performance	Nr workers	Hours	Days
Scaffold assembly	m	250,00	0,13	6	8	0,68
Framework	m	978,74	1,50	6	8	30,59
Thermal and sound insulation with vapor barrier	m ²	978,74	0,15	6	8	3,06
Ceramic tiles	m ²	978,74	0,85	6	8	17,33
						51,65
						TOTAL 51 DAYS

Table 10. Duration of roof works

3. ORGANIZATION PART

3.1 ANALYSIS OF CONSTRUCTION MASTERPLAN

3.1.1 DESCRIPTION OF THE TERRITORY

The plan of building lot is composing for a construction of multi-dwelling building in Vilnius (Lithuania), Vingriu Street 3A. In the plan of building lot is intended:

- The main machines working places and moving tracks;
- Storages and storing sites positions;
- Temporary electricity, water-supplying, sewerage and fireplug, positions;
- Safety and dangerous zones;
- Territory and dangerous zones enclosure, roofs and so on;
- Temporary access roads and passages;
- Temporary buildings and domestic rooms positions.

The plan of building lot is preparing before start the construction works. All the site preparation has to be made according to construction organizing project.

After get the suitable permit for occupied public area, we will place the temporary worker buildings in the street. In consequence the fence will include more than the plot area in the unnamed alley side, however in Vingriu street there is not place for transit so the fence is close to the border of the lot.

Actually at the beginning of the works the plot was surrounded by a wooden fence and the interior of the plot was full of weeds so before starting with works it was necessary to clean the plot.

Because of the characteristics of the building and the requirements of the construction works the installation of a crane is only necessary during structure works. The working zone of crane and other dangerous zones will be marked.

However it is very important the assembly of scaffold for build up the façade and some parts of the roof.

On the preparation stage, the following works are supposed to be done:

- Prepare the auxiliary workers and managing staff building;
- Cleaning of plot area;

- Installation of fences and marking and signage for the work site;
- Prepare storage sites.

All the auxiliary buildings for workers and managing staff will be supplied by water and electricity by temporary connections to the existing network. The building is also provided with electricity and water by temporary connections to the existing former networks.

3.1.2 SELECTION OF THE CRANE

The selected crane is LIEBHERR 110 EC-B6.
We chose this crane according in technical parameters.

For make the calculations, we have to know in advance the following parameters:

1. The dimensions of building and location (underground and over-ground parts).
2. The weights, dimensions and location of installing constructions.
3. The work conditions (the peculiarities of building site, soil characteristics and the peculiarities of underground structures).

First of all, we must check if crane technical characteristics match the inequalities:

$$\begin{aligned} Q_k &> Q_R. \\ H_k &> H_R. \\ L_k &> L_R \end{aligned}$$

Here:

Q_k – the ascension power of selected crane, t

Q_R – the required ascension power, t

L_k - the reach of selected crane boom, m

L_R - the required reach of crane boom, m

H_k - the lifting height of selected crane hook, m

H_R – the required lifting height of hook, m

The technological parameters of crane are calculating according to the building characteristics. The required crane is selecting according to the tables of technical characteristics of cranes.

In order to calculate the required height of hook lifting we use the following formula:

$$H_R = \text{Building height} + 3\text{m} = 23 + 3 = 26 \text{ m.}$$

The ascension power of crane:

$$Q_r = P + P_{str} = 2.5 + 0.15 = 2.65\text{t}$$

P -weight of heaviest lifting construction, t (in our case concrete container)

P_{str} - weight of hitching equipment, t

When the values of L_r , H_r and Q_r are calculated, the crane could be selected. Whereas for determining the reach of crane boom L_r , will be needed to know the under crane with of supports and dimensions of platform turn. These values are found in crane diagrams.

The reach of crane boom L_r is calculated according to our needs. I decide to put the crane in the underfloor of the building, approximately in the middle of the building, because this part is for courtyard so the crane only disturb for underground floorings.

$L_r = 30 \text{ m}$.

When we know the values of L_r , H_r and Q_r , the crane could be selected using the diagrams of the tower crane.

The diagrams show that the crane we can use is LIEBBHERR 110 EC-B6.

$Q_k > Q_r \text{ } 3 \text{ t} > 2.65 \text{ t}$

$H_k > H_r \text{ } 30 \text{ m} > 26 \text{ m}$.

$L_k > L_r \text{ } 32.5 \text{ m} > 30 \text{ m}$

As we can see, the crane we have selected is capable of performing the required works.

During the installment works in some parts of the construction site, bars, workplaces and crossings the dangerous areas are appearing. During the construction such areas are known as dangerous zones. At the beginning of construction works and during construction dangerous zones, in which constantly arise or may arise risk factors should be determined. The dangerous zones are dividing into two groups:

1. Dangerous zones in which dangerous and/or hazardous factors constantly affect the processes.
2. Dangerous zones in which dangerous factors could appear.

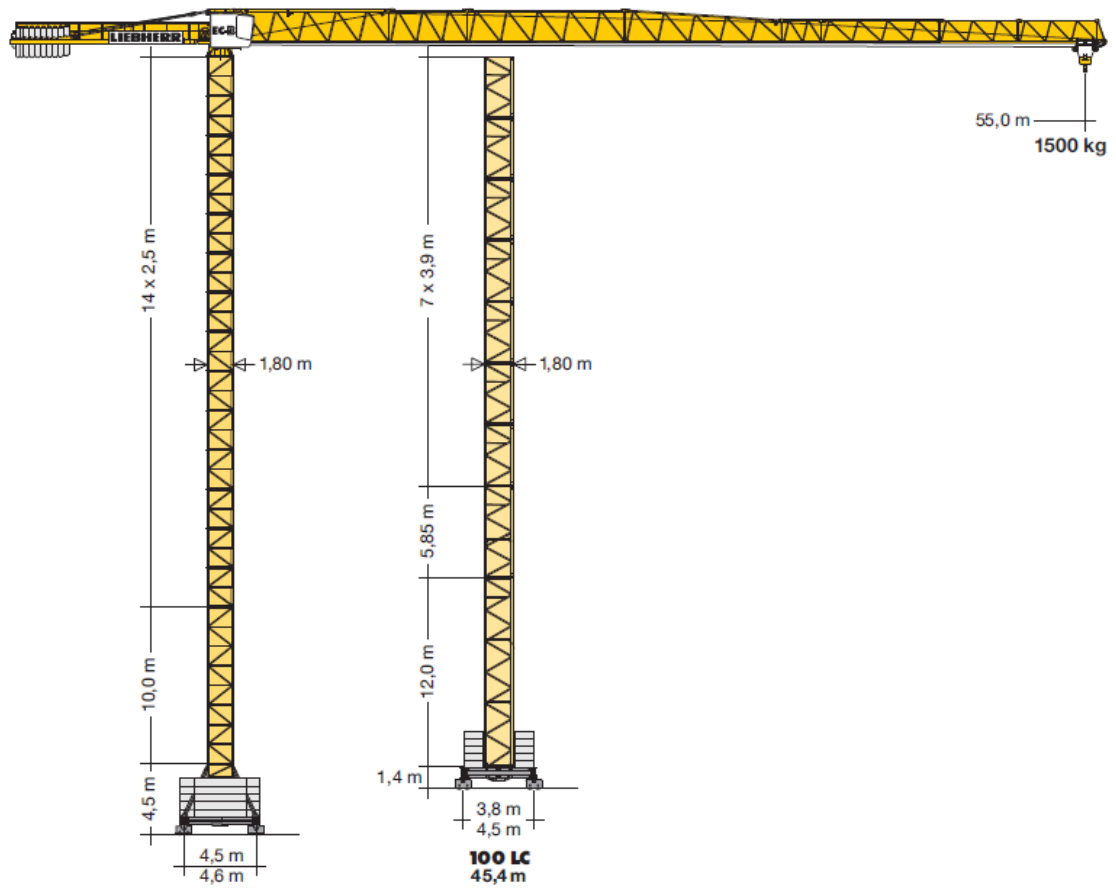

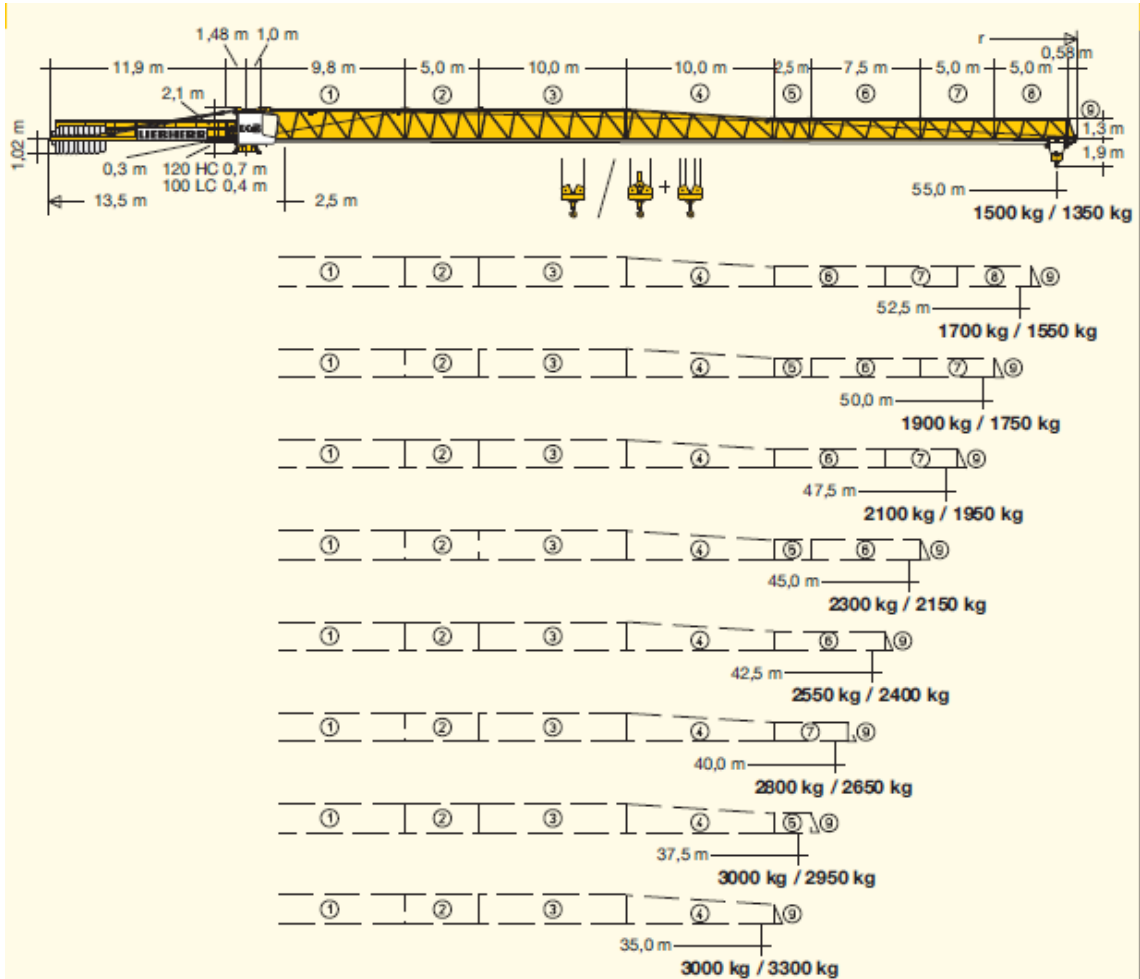

m	r	m/kg	m/kg														
			20,0	22,5	25,0	27,5	30,0	32,5	35,0	37,5	40,0	42,5	45,0	47,5	50,0	52,5	55,0
55,0	(r = 56,5)	2,5 - 31,1 3000	3000	3000	3000	3000	3000	2860	2620	2410	2240	2080	1940	1810	1700	1590	1500
52,5	(r = 54,0)	2,5 - 32,8 3000	3000	3000	3000	3000	3000	2780	2560	2380	2210	2060	1930	1810	1700		
50,0	(r = 51,5)	2,5 - 34,1 3000	3000	3000	3000	3000	3000	2910	2690	2490	2320	2160	2020	1900			
47,5	(r = 49,0)	2,5 - 35,1 3000	3000	3000	3000	3000	3000	3000	2780	2580	2400	2240	2100				
45,0	(r = 46,5)	2,5 - 35,9 3000	3000	3000	3000	3000	3000	3000	2850	2650	2460	2300					
42,5	(r = 44,0)	2,5 - 37,0 3000	3000	3000	3000	3000	3000	3000	2950	2740	2550						
40,0	(r = 41,5)	2,5 - 37,7 3000	3000	3000	3000	3000	3000	3000	3000	2800							
37,5	(r = 39,0)	2,5 - 37,5 3000	3000	3000	3000	3000	3000	3000	3000	3000							
35,0	(r = 36,5)	2,5 - 35,0 3000	3000	3000	3000	3000	3000	3000									
32,5	(r = 34,0)	2,5 - 32,5 3000	3000	3000	3000	3000	3000										
30,0	(r = 31,5)	2,5 - 30,0 3000	3000	3000	3000	3000											
27,5	(r = 29,0)	2,5 - 27,5 3000	3000	3000	3000												
25,0	(r = 26,5)	2,5 - 25,0 3000	3000	3000													
22,5	(r = 24,0)	2,5 - 22,5 3000	3000	3000													
20,0	(r = 21,5)	2,5 - 20,0 3000	3000														

				100 LC									
3,9 m	3,9 m + 5,85 m	5,85 m	11,7 m										
10	9+1	7		-	-	41,8°	-	41,9°	-	41,2°	-	40,0°	-
	8+1			-	-	39,8	-	39,9	-	39,2	-	38,1	-
9		6	3	-	-	37,9	49,5°	38,0	49,6°	37,3	48,9°	36,1	48,1°
	7+1			-	-	35,9	47,5	36,0	47,6	35,3	46,9	34,2	46,1
8				33,8	45,4	34,0	45,6	34,1	45,7	33,4	45,0	32,2	44,2
	6+1	5		31,8	43,4	32,0	43,6	32,1	43,7	31,4	43,0	30,3	42,2
7				29,9	41,5	30,1	41,7	30,2	41,8	29,5	41,1	28,3	40,3
	5+1			27,9	39,5	28,1	39,7	28,2	39,8	27,5	39,1	26,4	38,3
6		4	2	26,0	37,6	26,2	37,8	26,3	37,9	25,6	37,2	24,4	36,4
	4+1			24,0	35,6	24,2	35,8	24,3	35,9	23,6	35,2	22,5	34,4
5				22,1	33,7	22,3	33,9	22,4	34,0	21,7	33,3	20,5	32,5
	3+1	3		20,1	31,7	20,3	31,9	20,4	32,0	19,7	31,3	18,6	30,5
4				18,2	29,8	18,4	30,0	18,5	30,1	17,8	29,4	16,6	28,6
	2+1			16,2	27,8	16,4	28,0	16,5	28,1	15,8	27,4	14,7	26,6
3		2	1	14,3	25,9	14,5	26,1	14,6	26,2	13,9	25,5	12,7	24,7
	1+1			12,3	23,9	12,5	24,1	12,6	24,2	11,9	23,5	10,8	22,7
2				10,4	22,0	10,6	22,2	10,7	22,3	10,0	21,6	8,8	20,8
	0+1	1		8,4	20,0	8,6	20,2	8,7	20,3	8,0	19,6	6,9	18,8
1				6,5	18,1	6,7	18,3	6,8	18,4	6,1	17,7	4,9	16,9
0	0	0	0	4,5	16,1	4,7	16,3	4,8	16,4	4,1	15,7	3,0	14,9
				-	12,2	-	12,4	-	12,5	-	11,8	-	11,0

3.1.3 SETTING OF DANGEROUS ZONE

Dangerous zones in which dangerous and/or hazardous factors constantly affect the processes, are:

- Near the electrical equipment with non-insulated parts electric current
- Fenceless zones at a height when height difference is 1.3 m higher
- Place where hazardous wastes and/or the concentration of harmful substances in workplace air may exceed the limit values.

Voltage, kW	Distances, limiting the dangerous zones from the fenceless un-insulated parts of the electrical equipment or from the vertical plane, which is the nearest power line wire, with a projection on the land, m
<1	1.5
1-20	2.0

35-110	4.0
150-220	5.0
330	6.0
500-750	9.0
800(current)	9.0

Table 11. Limiting the dangerous zones from the fenceless un-insulated parts of the electrical equipment

The limits of dangerous zones where the risk factors of harmful substances exceeding appears should be determined by measurement.

2. Dangerous zones in which dangerous factors could appear are:

- Near buildings under construction and assembling/dismantling buildings structures or equipment.
- Places over which the structures or equipment installation/dismantling works are executing.
- Places over which loads are lifting and transported by cranes.
- Places where the machinery, their parts or work equipment are moving.

The limits of dangerous zones where there is a transfer of elements performed by crane are determined by calculations, the sum of horizontal projection of lifted element, the maximum length of biggest elements and its possible fall distance.

Due to the conditions surrounding our lot we have to consider our danger zone should not override existing buildings. Then, let put some limitations on the movement of loads with the crane:

- Raise the load vertically to a reasonable height, and then carry the load to the centre turning radius to reduce the area of danger zone.
- The projection of the arm of crane will not be performed on existing buildings.

The next risk will be considered:

-Presence of obstacles.

-Areas of way.

-Jobs in proximity to high voltage power lines.

The prevention measures are established on the basis of the following legal text:

-Royal Decree 836/2003 of 27 June, approving a new Technical Instruction "MIEAEM2" Regulations Lifting and handling equipment, referring to tower cranes for construction or other applications.

-Royal Decree 1215/1997 of 18 July, laying down minimum safety and health for use by workers in teams.

Presence of obstacles

In paragraph 7.3 of the UNE 58-101-92, states: “The vertical clearance between the pen and the last area of movement of personnel shall be minimum 3 meters. If the load or empty hook passes within 3 meters of the area, will be necessary placed on it enough to prevent the indicators of his approach.”

This means that when the crane weathervane turn must respect the distances. And the area, which inevitably we must consider the burden.

We are not inclined to use signaling and also taking into account the flexibility of these structures, walkways in paragraph 4.1 of the UNE 58-101-92 states: “The minimum clearance for the passage of personnel, among the most prominent parts of the crane and any obstacle is 0.60 meters wide and 2.50 meters high. In case of failure application of this condition will prohibit the access of staff to this area dangerous”. We have considered a minimum distance between the tip of the arrow and the nearest obstacle of 2 meters

3.1.5 TEMPORARY ACCESS TO THE WORK SITE

There is enabled one access from Vingriu Street. Due to the characteristics of the streets, there is only one enabled access, it is from Vingriu Street. This access is able to use for machinery, for bring the materials, equipment and so more.

The width of the street is suitable to permit the passage for the trucks, the necessary trucks during construction works.
Temporary roads are built to bring construction materials.

The wide of the road has to be at least 6 meters, and the smallest distance from the road to the storage place is 1 meter. These roads are built to ensure easy driving to the building place and fast work.

3.1.6 TEMPORARY STORAGE AREAS

The storage areas are planned some of them inside of the building when is some part already built and others outside, but always all the materials will be inside of fence perimeter.

The areas managed inside the building are planned according to the schedule and the works performed in this areas.

The main exterior storage area is placed between the building and the fence, allowing a suitable passage for workers, machinery and others.

3.1.7 TEMPORARY BUILDINGS FOR WORKERS AND MANAGING STAFF

The workers and the managing staff will have their own temporary building in one area close to the works site, this building will satisfy all the necessities of the personal and is dimensioned according to the number of workers during the whole process of the construction works.

All the staff will have their own temporary buildings to satisfy all their needs. We calculate all the necessary temporary buildings knowing the workers volume.

According on “Royal Decree 486/1997, of 14 of April laying down general provisions minimum safety and health in the workplace” approaching the changing surface of 2 m² per worker.

The maximum number of workers that we will have working at same time will be 33. So we calculate 66 m² of surface for temporary changing building.

1 sink/ 10 workers

1 shower/ 10 workers

1 toilet / 10 workers

1mirror / 10 workers

$$S= 33 \times 2 \text{ m}^2 = 66 \text{ m}^2.$$

The workers will use a temporary buildings for rest, eat and changing work clothes and the other ones as toilet and shower.

The managing staff will have one temporary building, where will be situated the office.

3.1.8 TEMPORARY ELECTRICITY SUPPLY

We will need a temporary electricity supply installation with counter to electric company.

Mostly of works will need electricity to be done. This installation will have different derivation, one for crane, one for temporary buildings, one for other machinery.

A general electricity counter will be needed in the building fence connected to the electrical rush supply connected to the general electrical city system placed close the road, will be made an individual 4x16mm² derivation.

3.1.9 CONSTRUCTION SITE LIGHTNING

To calculate the number of luminaries necessary for the correct work illumination (Formula 3.1):

1 mirror / 10 workers

$$S = 33 \times 2 \text{ m}^2 = 66 \text{ m}^2.$$

Chosen Buildings:

- 1 Toilet Model M 65 (6.00x2.44m) = 14.64 m².
- 1 Model M 6C (6.00x2.44m) = 14.64 m².
- 1 Model M 6 (6.00x2.44m) = 43.92 m².

The workers will use a temporary buildings Model M 6 as place for rest, eat...; and the Model M 65 as toilet and shower.

The managing staff will have one temporary building Model M 6C, where will be situated the office.

3.1.10 TEMPORARY ELECTRICITY SUPPLY

A temporary supply will be needed in order to make mostly all the works. A general electricity counter will be needed in the building fence connected to the electrical rush supply connected to the general electrical city system placed close the road, will be made an individual 4x16mm² derivation.

3.1.11 CONSRUCTION SITE LIGHTNING

To calculate the number of luminaries necessary for the correct work illumination we use the following formula:

$$N = \frac{E \times A}{\phi_n \times F_U \times F_M}$$

Where:

N: Luminaries number are required

E: Average luminance in lux

A: Local area m²

ϕ_n : flow lamp rate in lumens

F_U: Factor of use

F_M: Maintenance factor

The surface of the work area is 1,679.4116 m², to be illuminated with an average illumination of 15 lux, with 1x150 W metal halide lamps, which produce a luminous flux of 13000 lumens per lamp. Will be used a normal maintenance factor 0.95.

Data from the lighting area are:

Length: 50.00 m

Width: 55.00 m

Height: 4.50 m

$$\text{Index } K = \frac{lxb}{h(l+b)} = \frac{1,679.4116}{4.50(50.00+55.00)} = 3.55$$

With this index, and media with floor colors and ceiling, and clearing to the walls, is a factor in initial use in direct lighting luminarie 1.

This the lamps number required will be:

$$N = \frac{ExA}{\phi_n \times F_{Ux} \times F_M} = \frac{15 \times 1,679.4116}{13000 \times 1 \times 0.95} \approx 2$$

By calculation we have obtained that we need a minimum of 2 lamps.

3.1.12 TEMPORARY WATER SUPPLY

We will need a temporary water supply. A general accountant will be installed in the building fence connected to the city water supply rush placed close to the road.

The temporary water supply line will require an accountant, stopcock general, pipe tube 32 mm, wash step and tap.

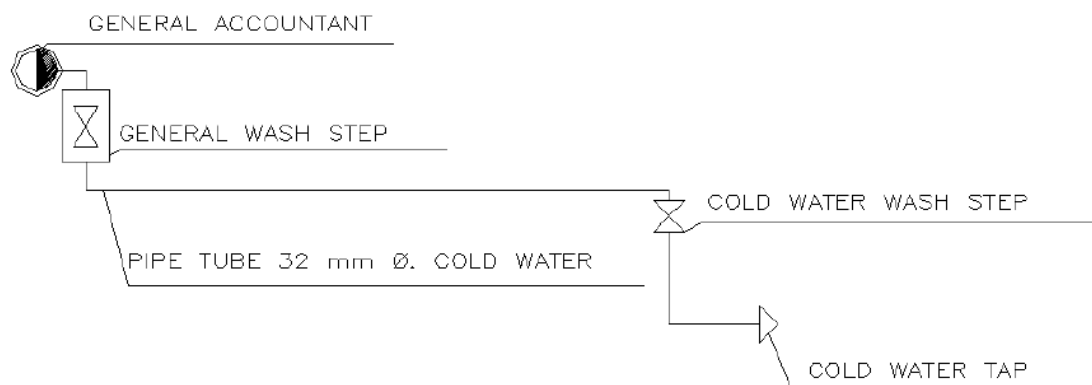

3.1.13 TEMPORARY SEWERAGE

The sewer construction will consist on removing water from rain and the elimination of waste water as a shower, basins and toilets.

Drainage is connected to the network of urban wastewater.

The drainage plan consist on connecting our network to existing networks of the city. The sewerage system will have a diameter of 200 mm.

3.1.14 FENCE OF CONSTRUCTION FIELD

The construction fence will protect the parcel's perimeter. The maximum width of the strip of public or private space to be occupied by work of fenced will be of 2 meters.

3.1.15 GENERAL REQUIREMENTS OF LABOR SAFETY

Here we will evaluate the general hazards and choose the individual protective measures which must be available for workers protection.

List of hazardous jobs:

- Excavation works
- Working crane
- Reinforcement and concrete works
- Formworks installation
- Welding
- Height work
- Roof and facade installation
- Installation works
- Work with hand tools and power machinery

Individual protective elements:

- The safety helmet is expected per worker every six month.
- The safety helmet with viewfinder, just one every ten workers is expected, because their use is more specific than normal helmets.
- Helmet with ear protectors: Is provided to one every five workers.
- Safety glasses: Are expected every three workers.
- Hearing protection (foam earplugs): Some ones per worker every two month for works around loud noises.
- Fine dust filter mask: One per worker every two month.
- Gloves: Some gloves per worker every six month.

- High resistance to cutting and abrasion gloves: One every five workers every six month.
- Welder gloves: A pairs of gloves for welder every ten workers every nine month.
- Dielectric gloves: Two pairs, their use is limited for electrical work.
- PVC Boots: A pair of boots every five workers every nine months for work duration.
- PVC water boots: A pair of shoes per worker every nine months of work duration.
- Dielectric boots: Two pairs for all the work, their use is limited for electrical works.
- Seat belt lifeline: One every ten workers and twelve months of work, for working at height together with safety lines.
- Safety belt: One every three workers and six months.
- Device fall arrest safety belt: One every three workers and six months.
- Fall arrest system: One every three workers and six months.
- Strip back injury protection: One worker for nine months of working duration.
- Overall: One per worker every six months.

Collective protective elements:

- Safety net: under first structural floor, only wherethere are more than 1 floor.
- Safety harness: One per worker.
- Perimeter railings: One on each working floor.
- Walkways and ramps at the same or different level.
- Working platforms: for height works.

3.1.16 ENVIRONMENTAL PROTECTION REQUIREMNTS

We must have planned the management of wastes generated during the works.

There must be a previous study for wastes, classified according their nature and dangerousness, and the will be checked which can be recycle and which cannot.

With this plan of construction wastes, when construction works are finished, wastes must not stay in our field.

During works execution we will have different containers for separate wastes.

We must appoint one person who will control the management of wastes.

3.1.17 FIRE PROTECTION REQUIREMENTS

Before the construction we must consider the fire risk and the damage that this may cause. We will do a risk study and establish fire safety measures and means of protection and fire suppression.

During the construction works, rules about fire protection will be followed-construction works and installation of fire protection rules.

In the construction site will have a visible and accessible place where there should be a panel with inventory:

- Two buckets
- Two axes
- Two crowbars
- Ladders
- Hook
- 0.5m³ of sand box
- Two fire extinguishers
- Two spades

4. BIBLIOGRAPHY

WEB PAGES

- < <http://www.youtube.com/watch?v=apbrHLScoVE> > Quality control
- < <http://www.youtube.com/watch?v=DdC2TRORFsc> > Quality control
- < <http://www.youtube.com/watch?v=MEIhjDk95-E> > Quality control
- < <http://www.lineaprevencion.com/ProjectMiniSites/Video5/html/cap-2/db-prl-cu/db-prl-cu.htm> > Roof works security
- < <http://eu-heritage2013.kpd.lt/19/14/0/vilnius-city-tour/> > Historical view
- < http://www.viv.lt/vilniaus_fenomenai/senamiestis_unesko_paveldas > Historical view
- < <http://www.respublika.lt/> > About Architect
- < <http://krumber.com/Wind%20Insulation.htm> > Wind insulation
- < <http://great-home.co.uk/a-guide-to-roof-construction/> > Roof works
- < <http://www.layher.com/layherderstarrahme.aspx?cls=02> > Scaffold
- < <http://www.vingriunamai.lt/en/> > Architectural part
- < <http://www.generadordeprecios.info/> > Costs and performance base data of Construction works. España. CYPE Ingenieros, S.A.
- < <http://www.almacenesnoroeste.es/catalogo/Catalog/show/lamina-drenaje-474> > Geotextile
- <[http://www.laneroofing.co.uk/marketingbox/documents/generic/682732553_LATEXFA LT_PARKDECK.pdf](http://www.laneroofing.co.uk/marketingbox/documents/generic/682732553_LATEXFA_LT_PARKDECK.pdf)> Courtyard finishing coat

< <http://www.hormigónimpreso.es/> > Terrace finishing coat

< <http://www.knaufinsulation.co.uk/#axzz32vtYRXgb> > Insulation layer

<CTE Código Técnico de la Edificación>

<Normas UNE>

<Riunet Universidad Politécnica>

<Apuntes profesores Universidad Politécnica>