

Corrugated glass as improvement to the structural resistance of glass

NIJSSE, Rob.

ABT / TU Delft, the Netherlands, r.nijisse@abt.eu

Abstract

It is a well known fact that if we take a flat piece of paper in our hands it is a weak, and slack.. However if you fold this piece of paper a few times the structural behaviour changes from weak to strong and from slack to stiff. Luckily enough the glass manufacturing firms are more and more capable to create folded, or better, corrugated glass. Therefore we have started to create glass structures in corrugated glass. Two well known buildings have incorporated corrugated glass in their facades. They are the Casa da Musica in Porto (P), (architect OMA) and The Museum aan de Stroom (MAS) in Antwerp (B), (architect Neutelings Riedijk). Two other projects are on the drawing boards; the University Library in Qatar (architect OMA) where a diamond shaped building has on four sides large facades composed by corrugated, insulated glass units up to a height of 17 meter and a villa in NL by MVRDV architects where corrugated insulated glass units carry the roof. In these four buildings the corrugated glass panels are used to create, with a relatively thin sheet of glass an all glass facade without hardly any steel components..

Keywords: Glass, Corrugated, Façade.

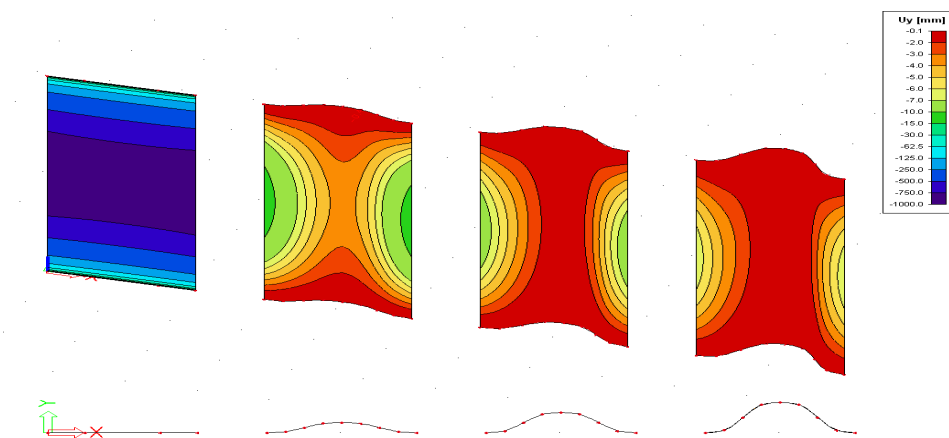

Fig 1. The effect of corrugate-ness on the deformation, from 750 mm (blue, flat) to 5 mm (yellow, corrugated)!!!



fig 2. The Casa da Musica in Porto (P), note the big window; to be filled with only glass!

1. Casa da Musica in Porto (P)

In 1997 the Office for Metropolitan Architecture (OMA) headed by the Dutch architect Rem Koolhaas won a competition for the Cultural Centre of Porto in Portugal. They had designed a, rather surprisingly shaped box of white concrete that contained the various cultural activities that had to be housed in it. In the white concrete box, large, very large openings were made to let the daylight enter the building and to present to the visitors of the building astonishing view over the town of Porto, located on the slopes of the river Douro.

ABT/ Rob Nijse was asked to make a proposal for the façade of the large windows, the biggest one measures 25 by 12 meter, using as much glass as possible and, preferably, no steel. We tried all kind of slender cable stayed structures but these remained unacceptable for the architect. Quote; “I don’t want all that steel spaghetti around the glass”. As we tried to figure our way out of this “mission impossible” I happened upon a publication of the Spanish firm Cricursa that made a large corrugated panel wall for the interior of a shop. Putting one and one together I made a proposal for a large window made out of large

corrugated glass panels stacked on top of each other. Due to then valid production restrictions we could make 4.5 meter high corrugated glass panels, so the total height of 12 meter was divided in three parts which luckily enough fitted in with the position of the floors of the foyer/ circulation space that sometimes passed through the voids. The architects immediately embraced the proposal. As I later learned especially the contrast between the flat, smooth surface of the white concrete and the corrugated, shining, brilliant surface of the glass façade was appealing. The structural effect of a corrugated panel is clear; it can take up much more wind load then a flat one with the same thickness. Therefore no steel supports in the shape of cables, columns and beams are necessary for the glass. On an overall level support for the components of the façade is still needed. We combined these with the planes of the floors that crossed the voids behind the façade. Here were placed horizontal steel trusses made as slender as possible; so crossed diagonals in order to have always one on tensile stress. At places were there is no floor these diagonals simply hang in the air.



Fig. 3. In between the two corrugated glass walls a cavity to reduce the sound level between the two spaces.

The architect wanted to have daylight in the big Auditorium, a feature rarely seen in theatres. So we had to make two walls of corrugated glass, one wall on the outside, to take up the wind load and to provide water tightness and insulation and one wall on the inside dividing the theatre from the foyer/ circulation area. It might be suspected that sound quality inside the theatre was affected by the presence of glass, a hard reflecting material. Study of the acoustical adviser learned that due to the corrugated surface a very effective dispersion of the sound was obtained and the effect of double glass wall resulting in a more than enough sound level reduction from inside to outside and the other way around.

The weight of the corrugated glass walls is carried by steel beams that are hung up to the concrete wall on top of the opening in the concrete shape of the building. In total six, more or less large, openings in the white concrete box were filled with this concept of corrugated glass walls.



Fig. 4. The view through the corrugated glass panels.

These steel beams are a part of the horizontal steel trusses and have facilities for both mounting and adjusting the tolerances of the corrugated glass panels. Also waterproofing and thermal separation between outside and inside is taken care of.



Fig. 5. The façade of the Casa da Musica ; corrugated glass and white concrete : an unexpected beautiful match.

3. Museum aan de Stroom (MAS) in Antwerp (B)

A desire to improve the quality/atmosphere of the old disused harbour quarter directly situated near the historic City centre of Antwerp, led to plans to develop a new large Museum on an island in the Antwerp City harbour. A museum meant to house all the museums in Antwerp housing subjects diverting from historic to folkloric and modern art.

In 2000 an architectural competition was scribed out for 5 selected architects. The competition for the 12.000 m² floor space building was won by Neutelings Riedijk Architecten with ABT as structural advisor.

The design of Willem Jan Neutelings was simple but beautiful. By housing each category of the museums in a concrete flat box, security, fire proofing and optimal climate control was possible. By placing the in total eight boxes of the museums on top of each other and putting a entrance layer on ground floor and a restaurant on top a 60 meter high building was created. The stroke of genius on the part of the architect was that by twisting each layer of this stack of boxes over 90 degrees a spiral walkway connecting the various museums boxes was made. An other result of this twisting is that the visitors climbing up, while doing so, also have beautiful views over the city of Antwerp, each time from a different direction.

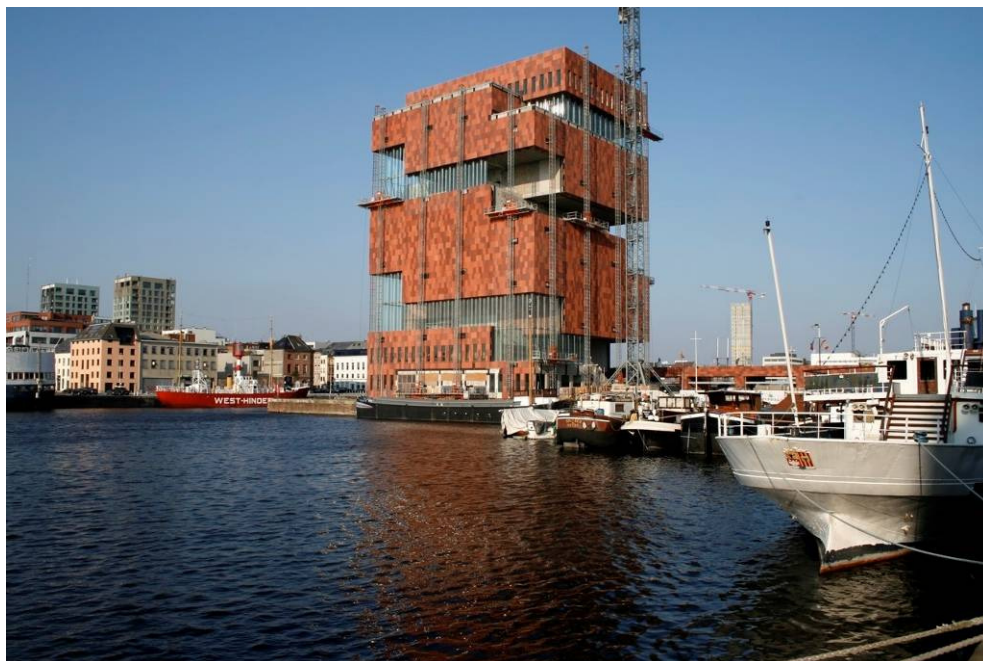

Fig.6. The building of the Museum aan de Stroom (MAS) on the “Eilandje” in the old harbour of Antwerp.

Although the structure of the MAS itself is interesting the glass facades filling in the space between the various museum boxes are the subject of this paper. As one can see in fig. 8 the height of this façade at the corner areas is two times the story height of a museum box, being 5,5 meter, so an 11 meter high glass façade results. Of course the architect desired only glass as façade. From the experiences with the Casa da Musica project, that was that time in the Design phase, we were able to propose corrugated glass for this project as well. The special challenge of the MAS project was that here a façade of 11 meter in one go had to be realised. Corrugated glass elements of 11 meter long are an illusion; they can not be made in the furnaces and the glass industry has a 6 meter length limitation due to production and transport restrictions. The Italian glass provider Sunglass was able to produce the desired shape of corrugated glass in the length of 5, 5 meter. So we divided the 11 meter in two parts of 5, 5 meter. This implied a “support” halfway that, of course had to be as slender as possible to not undo the desired overall transparency (and view) of the façade. This item was solved by connecting the two corners of the adjacent concrete blocks with a steel tube as intermediate support halfway (see fig. 8). This tube is only meant to carry the wind load and serve as a horizontal support for the façade; the own weight of the façade is carried by simply stacking the corrugated glass panels on top of each other. So for wind load the corrugated glass panel behave structurally as a plate on two lines of support, spanning 5, 5 meter. Another serious critical point of the production of corrugated glass is the exactness in which the panel’s dimensions can be made. Preferably we would like all elements to have the same width, the same length and the same curvatures. Since it is a production process, that makes the elements one by one, exact uniformity is an illusion. It is our experience from the Porto and the Antwerp projects that tolerances of +/- 2 mm are possible. Regarding the shape of the corrugated glass panel the choice is made by the designers how an element should look. This is an architectural or visual issue but it may have large implications on the structural behaviour and the building costs. Also it relates to the number/ length of silicone joints that has to be made. In the respective projects, the Casa da Musica-Porto and the Museum-Antwerp this aspect will be dealt with specifically but in general the recommendation can be made to choice symmetric elements. This is not required by the manufacturing process although this has other restrictions to the shape. But that is dealt with by following a simple rule that states: if you can fold the desired corrugated shape out of piece of paper, the Glass Industry can make it. The demand mentioned here is made out of structural restrictions. It does not rule out a-symmetric cross-sections but one has to be aware that a-symmetric profiles means extra stresses in the material glass and this may mount up to 25%!

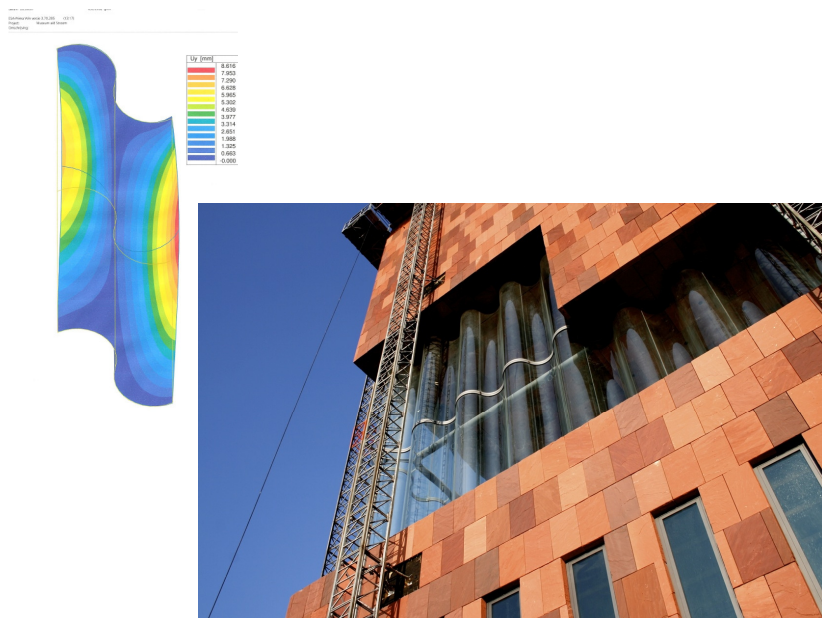

Fig. 7. The structural effect of being concave or convex for a corrugated surface.

The reason for this is that there is different behaviour in stiffness when a concave element (hollow shape) or a convex element (rounded shape) is loaded. The convex shape is weaker and deforms easier. Therefore, if we look at the shape of the corrugated glass panel in fig. 1 we notice that this a-symmetrical shape has a convex and a concave half.

The convex part will move more under loading and will flatten out in the middle of the field. The concave part will stay more in the original shape and the overall shape of the total profile will rotate in the direction of the convex part.

However at the supports, the corrugated glass panel is forced in the steel profile that makes the support by clamping the glass (with an elastic intermediate). There the deformed, rotated shape is forced into the original radius, resulting in extra stresses in the glass and this may go as high as 25% more, locally at the supports. Also the vertical joint along the side of the corrugated glass panes will behave accordingly; during loading the joint will be broader in the centre of the span and smaller at the supports. This will cause tensile stresses in the silicone joint resulting in possible tearing and leaking of the joint.

The fact that the glass panels are merely standing on each other led to some discussion.

One; are the stresses called up by this stacking acceptable? And two; if a lower panel breaks, to whatever cause, will the top one not come down? and three; can the broken panel be replaced? Question one : stress level is depending on the spread made by the elastic

layer between the two stacked corrugated glass panels. The level of normal stresses (compression) varies from 2 (concentrated points of support) to 0, 2 N/mm²(uniform support), very acceptable values certainly for compression, one of the strong features of the material glass. Second question; breakage lower panel: if one simply let the panels stand on top of each other, this is a problem. Also in combination with question 3: the replacement, this is a critical aspect. Therefore it was decided to add a steel horizontal beam that was strong enough to carry the weight of the top one, when the lower panel collapsed, but slender enough to be incorporated.

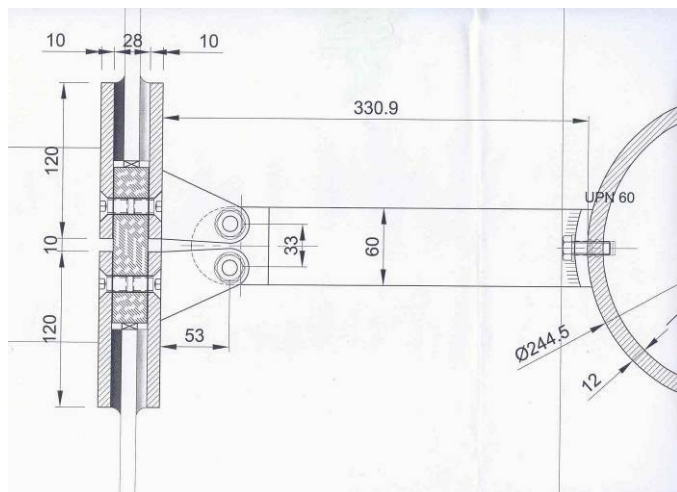

Fig. 8. The horizontal, intermediate connecting middle detail of the 11 meter high corrugated glass façade of the MAS.

As one can see in fig 7, steel plates follow the shape of the corrugated glass in order to make a good detail, easy to maintain and assemble. The making of the corrugated steel profiles proved to be difficult in practice since the steel always has an uncontrollable tendency to spring back after deforming and the effect of temperature change was also apparent. These problems were solved by extra attention and control during manufacturing and by making the steel elements not too long; more vertical joints were added. The waterproofing is guaranteed by silicone joints at both the in- and the outside. The connecting detail at the underside and the upper side was worked out with the same principle. Beauty is in the Details, so it is important to perfect them; also we have to have an open eye for maintenance and cleaning.

Up to now we have been talking about “a” corrugated glass panel. But how do you choose the corrugate ness of a corrugated panel? Two different visions have to come together; the structural engineer who wants to have a really present “wave-height” and the architect who wants to have a undisturbed view on the surrounding i.e. a flat as possible panel. During

this discussion we made some reconnaissance calculations that learned that from a ratio of 1 to 20 of the wave-height to span the structural effect of the corrugate ness was evident. So we stuck to that but the architect reacted by doubling this value with the argument that view distortional effect from a distance is less and that people could stand “in” a wave of glass close to façade. The distortion close to the glass is also minimal. All this implied that our “wave-height” is now 2 X 300 is 600 mm. The elements were chosen to have the shape of a lying S, with a width of 1800 mm. We calculated a required glass thickness of 12 mm float glass.

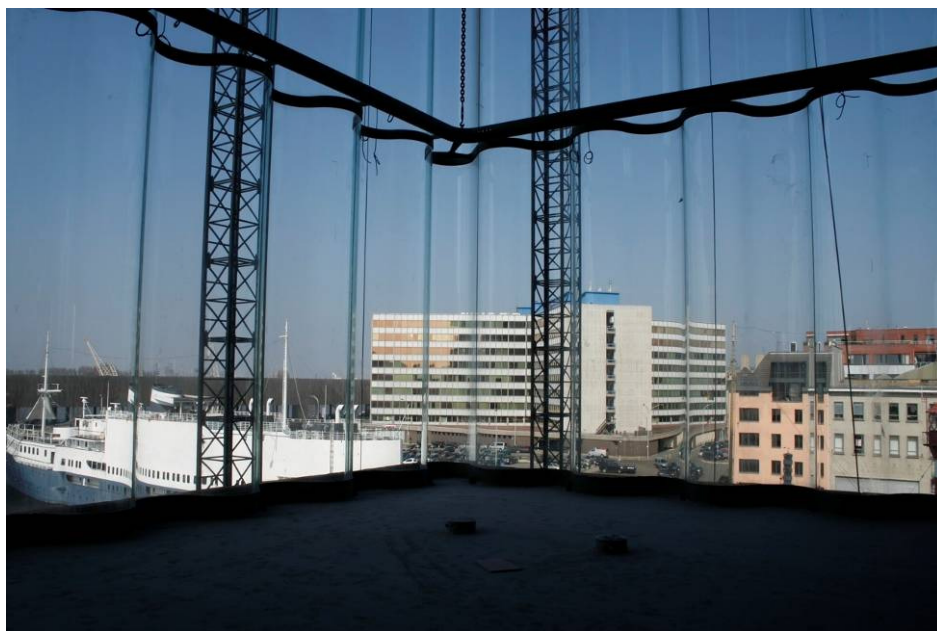

fig. 9 The view through the 11 meter high corrugated glass façade on Antwerp. Note the horizontal tube giving support halfway for the wind

4. Future Applications for Corrugated Glass Panels.

Now it is possible to make facades out of corrugated glass, even in laminated glass and insulated glass units, we may think about another possible use in the construction of buildings.

1. **Roofs.** Why not? If the improved statical behaviour (compared to flat glass panels) works for the windload; why not for the dead load or the snowload when it is placed horizontally, as a roof? The transparency combined with the natural watertightness of glass makes it a very interesting roofing material. Of course sunshading is an important issue that has to be taken care of. The drawings below illustrate the possibilities of corrugated glass as a roof.

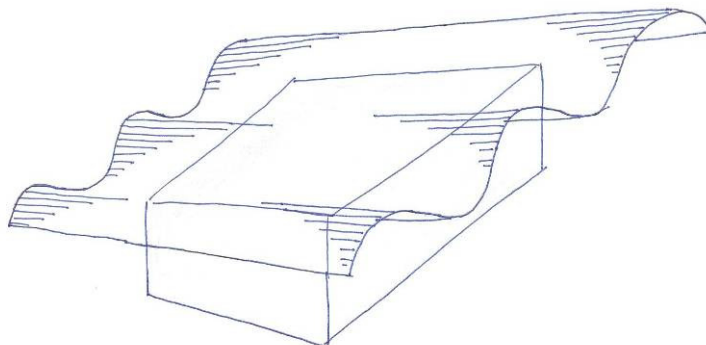

Fig. 10. A corrugated glass roof

2. **Walls.** Flat glass panels have a very unfavourable structural behaviour concerning axial loads. Buckling or plying will occur very quick at already low normal-stress levels. For corrugated glass this is far better. A simple test with a piece of folded paper to act like a wall demonstrates the enormous rise in bearing capacity compared to the same piece of paper as flat panel. Also from a stability point of view : a flat panel tilts over easily while a corrugated panel stands firmly, a choice

for a corrugated panel is obvious. We did make a proposal for a load carrying, corrugated and insulated glass wall as a perimeter to a villa designed by the Dutch architects MVRDV. It would have been a fantastic sight, the German firm of Finiglas was able to make the corrugated insulated glass units in a save and even cost-likely attractive way : 120% if compared to a standard brick wall with large glass windows.

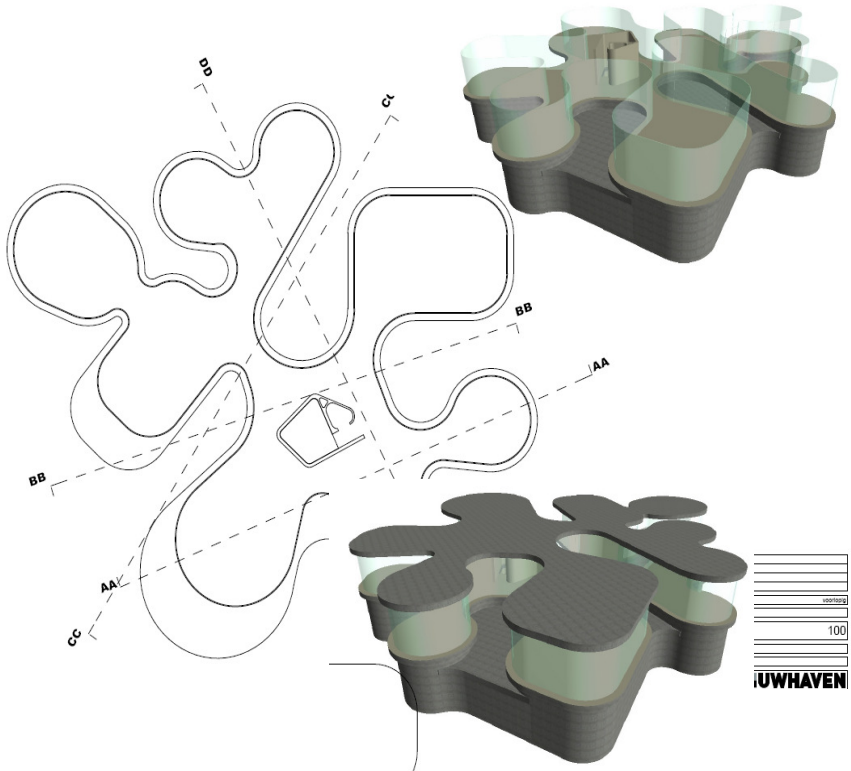

Fig 11. Renderings of Villa Hunting in the Netherlands designed by MVRDV.



Fig. 12 Internal view of the villa Hunting with load carrying glass walls.

5. References

- (1) Knaack, Ulrich, *Konstruktiver Glasbau*, Verlag Rudolf Müller, Köln, Deutschland, 1998
- (2) Nijssen, Rob, *Structural Glas*, Birkhäuser, Basel, Switzerland, 2003.
- (3) Neutelings Willem Jan et al, *At Work!*, Uitgeverij 010, Rotterdam, the Netherlands, 2004.
- (4) *El Croquis 131/132*, OMA Rem Koolhaas, Croquis editorial, Madrid, Spain, 2006.