

Helical industrial chimneys in Spain

Gracia Lopez Patiño

Department of Architectural Construction, Polytechnic University of Valencia, Spain

Abstract

The industrial chimney has been the symbol of the Industrial Revolution par excellence. Transcending both regionalism and traditional forms of construction, some specimens found in Spain, dating mainly from the early twentieth century, follow unique schools of construction with regard to the mastery with which the brick is handled. All this was achieved without being endorsed by famous architects; rather they were the product of master masons, skilled in their craft and relishing the opportunity to give to the best of their ability. Currently unimaginable in today's construction climate, their work shows signs of enduring, despite their obsolescence and disappearance of their original function. One of the most beautiful and spectacular types of chimney, whatever cross section it has, is the helical chimney.

The paper reviews the origin of these chimneys and illustrates their various types of construction using both historical photographs of lost chimneys and photographs of some spectacular ones that have survived. In an interview with the author, one of the last great chimney builders explained how to erect a helical chimney using the tool he invented for the purpose. The paper ends by noting that heritage legislation in Spain is gradually including industrial heritage and that, in Valencia, industrial brick chimneys of merit, constructed before 1940, are now protected.

Keywords

Industrial chimney; helical chimney; industrial heritage; brick; Spain; Valencia; 19th – 20th century.

Introduction

As we saw in the opening ceremony of the Olympic Games in London, the symbol par excellence of the Industrial Revolution was and remains the industrial chimney. Already in the eighteenth century, mining for metal ores in the bowels of the earth led to the development of the steam engine to drain the underground galleries. Gradually that machine drifted into other applications including its use to evacuate the fumes generated by the combustion process. This move reflected both the emerging attitudes to healthy living and the need to increase the efficiency of the combustion process. This is why industrial chimney was born as an evolution of the domestic hearth. At first it was located very close to the boiler, in the same building, with its walls forming the simplest shaft cross-section that can be generated with a parallelepiped or cuboidal brick: a rectangle. Over time, and with increasing power of the machinery, the chimney acquired its independence from the engine house, becoming separated and, at the same time, increasing its height in order to increase the up-draught and the efficiency of the chimney. The question of its structural stability and the later development towards the design and configuration we know today are dealt with below.

The construction and styles of industrial chimneys varied according to the constructional traditions of the region, the builder's own preferences, and the prevailing tastes of the time.^{1 2} Thus, in Britain, there can be distinguished three completely different areas of industrial application, which each had their own influence beyond their place of origin. First, we have the county of Cornwall, whose industrial activity

was dedicated almost exclusively to mining. The basic building material for the pump houses and the boiler chimneys was stone, in particular, granite. Thus chimneys were constructed with this material, either in ashlar or rubble, and finished above in brick. The fireplace had a square base while the chimney was circular in cross-section. In Lancashire, on the other hand, the fireplace had a circular section and was constructed entirely in brick. Finally, in Yorkshire, whose industry was dedicated to textiles, the smoke shaft was usually built of stone, while the shape of the chimney itself was octagonal. From the mid-nineteenth century, some chimneys were built with an outward appearance that followed the new taste for the Italianate style, resembling the slender mediaeval towers of Bologna or Tuscany.

From the second half of the nineteenth century treatises on brick construction began to appear in which industrial chimneys were featured specifically in the colour plates or half-tone illustrations, and came to serve as a model for the rest of the world.³ Notable among these was the first major book on chimney construction by Robert Rawlinson (1810-98).⁴ There also appeared a number of books on the design and construction of the chimneys.^{5 6 7} For a better understanding of the theme of the paper, and the specialised language used, the configuration of a chimney will be explained in the following paragraphs.

Configuration of a chimney

In addition to the visible parts of a chimney that are easily distinguishable, there are other parts which are underground or invisible. These include the foundations, common to all construction, and various elements that are particular to this type of construction, such as the flue pipe.

The foundations were made of masonry and lime in the early years; concrete was introduced later, first as mass concrete and later strengthened by the incorporation of reinforcement. As with any building, the nature of the underlying piles depended on the characteristics of the ground and could be either piles with a cap for soft ground, or a solid cube of concrete for more resistant soils.

In the majority of cases, the flue pipe was situated underground, although it may also be partly visible. If the chimney was used in the production of lead, the flue had a large cross section to allow access for workers to remove the deposits of lead carbonate on the walls of the flue. For other uses, and according to the size of the boiler and, hence, the height of the chimney, the duct was much smaller. Executed also in brick in the form of a barrel vault, it was usually constructed after the chimney itself had been completed. Each chimney might have more than one flue pipe

The key elements of an industrial chimney, from the bottom to the top of the construction, are as follows. (Fig. 1)

Figure 1. General configuration of an industrial chimney. Chimney factory Aparici, Alcudia de Crespins (Valencia) (Photo: author)



The Base

Although usually constructed of brick, the base might also have been built in ashlar, or in brick with ashlar only at the corners, or in brick and ashlar, and even with alternating courses of brick and ashlar.

Having various shapes in plan, the base was typically between three and five metres high, either straight or sloping. The thickness of its walls was greater than in the rest of the structure because it had to bear the full weight of the chimney. There was also a small podium, a body in which there was located an opening through which the builders of the chimney gained access to the inside. It was provided of a cornice, normally overhanging, which protected the rest of the base from rainwater. The rare ornament of the base, effected by means of triangles and rhombic shapes of highlighted bricks, contrasts with the ever beautiful ornament of the cornices, which has recesses highlighted by the brick bond producing interplay of light and shade.

The Shaft

The shaft is the elongated tube through which the smoke and other products of combustion pass. The diameter of the shaft usually decreased on the outside at a slope of between 1% and 3%, although usually in the range 2.0-2.5%. The thickness of the shaft was reduced by one half a brick width (12cm) every 4-5m height, thereby reducing the overall weight of the chimney. (Fig. 2)

The cross section of the shaft in plan evolved in order to reduce the wind loads acting on the chimney. Initially chimneys were usually square in plan. To reduce wind resistance, the number of sides was increased to six or eight and eventually to a circular section. The octagonal form became the norm and in Spain there are some hexagonal examples.

The different parts of the chimney – the base and the shaft – could be constructed using different types of brick. When the shaft had a large diameter it could be constructed using bricks of normal shape (a parallelepiped or cuboid); alternatively it could be built of curved bricks in order to fit the curvature of the form. These pieces had the form of a part of the circular crown/annulus. For a shaft with octagonal section, the corner pieces were obtained as the intersection of two cuboid-shaped pieces of different length, forming an external angle of 135°. The wall between the corner pieces was made with normal bricks which originally were hand-made and later, with the introduction of the industrial processes, were extruded, either solid or perforated with holes.

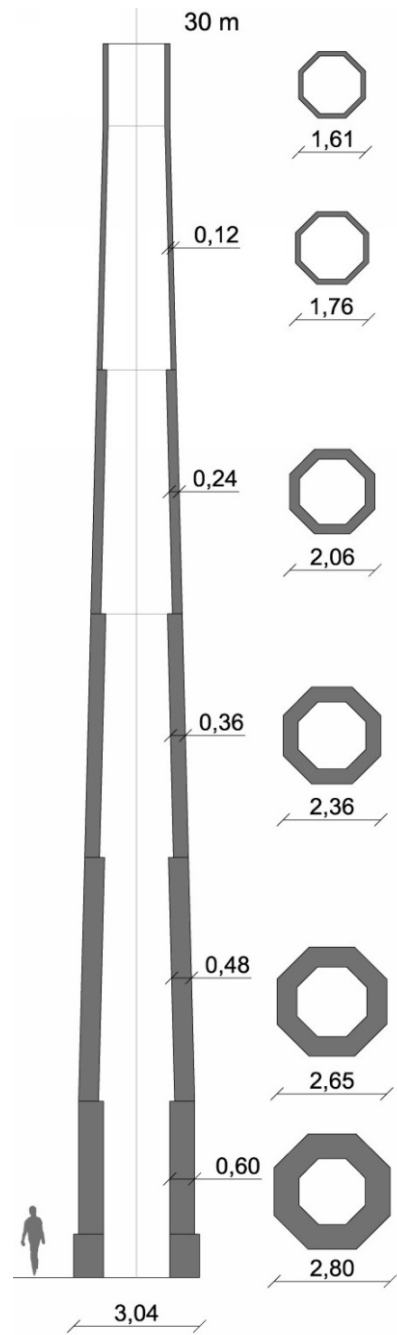

Figure 2. Cross section of a typical chimney (Drawing: author)

The decoration of the chimney was essentially created by the colour of the bricks due to composition and conditions of the firing. When a rotation of the brick courses about the vertical axis of the chimney was introduced, it was possible to create a helix. In the case of a polygonal section, this would form a helix, with an angle that rotated. For a circular chimney the helix could be created using moulded or coloured bricks.

The Crown

The top of the shaft is finished with the crown. This was the most decorated part of the chimney where the builder was able to show off his skill and flair. First there would usually be one or more rings that led into the body of the crown and then into a cornice, normally overhanging. The crown finished off with a narrowing section, formed of several courses of bricks, creating the nozzle from which the hot gases and smoke were expelled to the atmosphere.

Helical fireplaces in Spain

The present study focuses on industrial chimneys with a helical form found in Spain. (Fig. 3) This includes both those that achieve their helical appearance using coloured or even painted bricks, and those that are formed by the brick construction itself as the polygonal section is rotated from one brick course to the next around the vertical axis of the chimney.

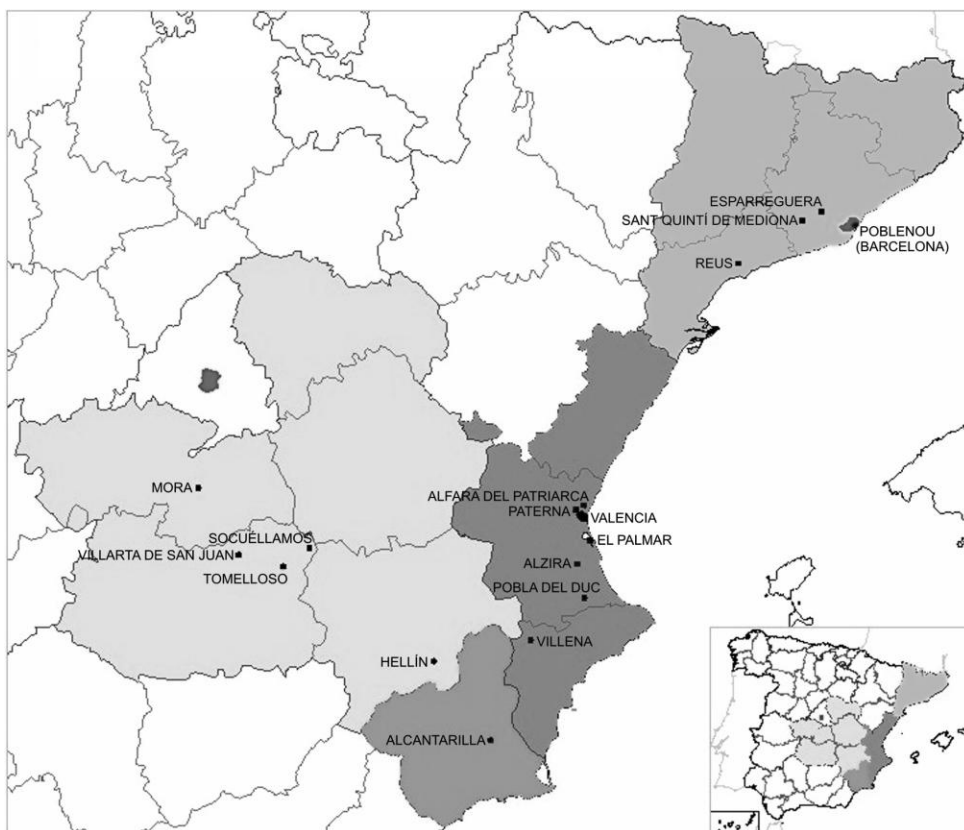

Figure 3. Map showing the distribution of helical chimneys in Spain

The Helical appearance

In construction, the brick of each course must interlock with the bricks of the course immediately below. In circular chimneys, the curved or standard cuboid bricks had a small horizontal displacement and rotation with respect to the course beneath. This fact was exploited by some builders to paint the brick a darker red and create a line that passes diagonally along the shaft around its entire perimeter and for the full height of the chimney. This technique was used in the old chimney of Cobarro's Industry (1916), demolished in 1989, in Alcantarilla (in Murcia), that has copies in Hellín (in Albacete) in the Garaulet brick factory (before 1935⁸) erected by the same Murcian builders, Juan Pacheco Pellicer (b.1858) and his team. Other builders, directly influenced by these Murcian masters, also used the technique in the chimneys at the distillery of Aníbal Arenas in Socuéllamos (in Ciudad Real) (1942), constructed by Pedro Alcañiz (1907-95). With the passage of time, the coloured paint had been lost in this chimney. The recent restoration of the chimney in 2005, by the wine cooperative Poble del Duc (in Valencia) (built in the 1960s) has returned the vivid colour and the helix that José Miñana (b.1932) wanted to show in his work. (Fig. 4) Rather less prominent than these helices are diagonal crossed lines created using a dark colour, but not red, in the chimneys of the ceramic factory La Peladera in Segovia (end of 19th century) (Fig. 5) and the sugar factory of San Joaquín (1884) at Nerja (Malaga). Both belong to the ruins of their old factories and no restoration has yet been undertaken.



Figure 4. Chimney at the Wine Cooperative Poble del Duc (Valencia) built by Jose Miñana in the 1960s (Photo: author)



Figure 5. The Peladera ceramic fireplace, Segovia, late 19th century. (Photo: author)

The current owner of Trilladora⁹ del Tocaio, in El Palmar de Valencia (Fig. 6) intends to activate the old abandoned complex where a ten metre high octagonal chimney with a truncated crown, dating from the beginning of the 20th century, stands, with a helix painted in dark red that survives, despite the passage



Figure 6. Chimney of Tocaio's rice thresher, El Palmar (Valencia) dated in the early 20th century (Photo: author)

of time. The particular character of this painted feature was achieved by the addition of vinegar to the paint, which fixes the colour in the material. The paint was applied prior to placement of the brick, by immersing the exposed face of the brick in a bowl of the treated paint.

In his home town of Mora (in Toledo), the builder Atilano Millas (1897–1952) used curved moulded bricks for the circular chimney of the soap works situated in the current Yegros Street (built in the 1940s) and, later, also at the Francisco Isla winery in Villarta de San Juan (Ciudad Real, 1952). (Fig. 7) In both cases, the base, like the shaft, was circular in plan and used the same moulded bricks to form small arches that are featured in the wall of the factory, the cornices in both the base of the chimney and the crown, both of which are built upon a serrated course of bricks placed vertically. The same feature is used to upper course of bricks in the 360° twisted shaft immediately below the crown.

The smallest diameter of the shaft in the chimney at the soap works implies that the action of the chords in the shaft form an almost Gothic (ogival) arch, while at the winery it forms a semicircular arch as in the base of the chimney. While the chimney of the winery has remained intact in the original courtyard, the chimney at the soap works has been integrated into a residential building.

Unidirectional helical twists

When the plan of the chimney shaft is polygonal, angular corner pieces mark the rotation or twist of the plane facets about the vertical axis.

A striking example of a chimney with unidirectional twist is to be found at an oil factory in Mora (in Toledo, date not known) built by Pelegrín Pipas (Fig. 8). The chimney has a square base, but the form of the shaft cannot be given a name because each course of bricks is serrated and rotated, creating a twist of about 35° to the vertical. (Fig. 9) The crown is also unique, with the brickwork being used to transform the circular section into a square which disrupts the appearance of the top of the nozzle section.



Figure 7. Chimney at the Francisco Isla winery, Villarta de San Juan (Ciudad Real) built by Atilano Millas in 1952. (Photo: author)

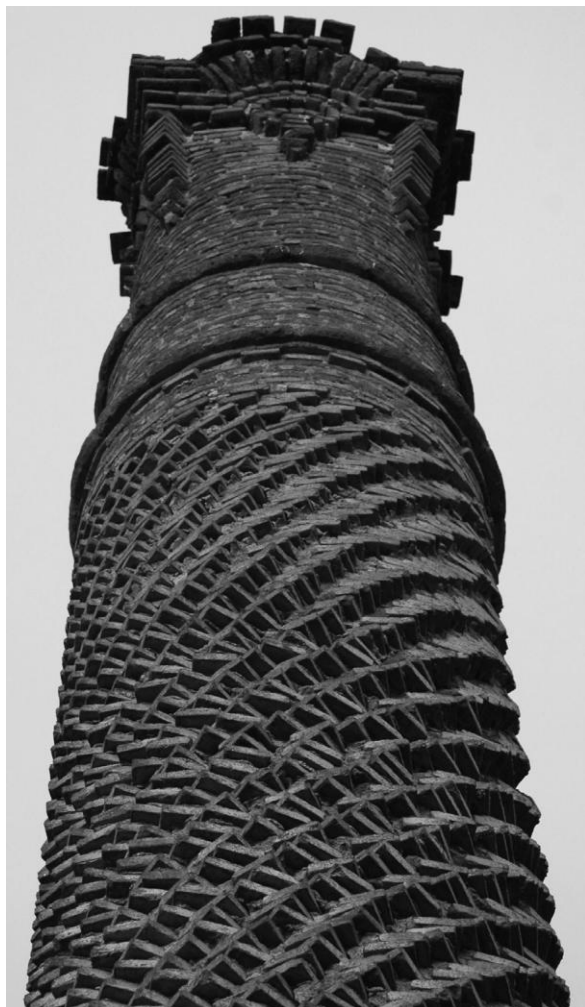

Figure 8. Chimney Pelegrin Pipas, Mora (Toledo) Bodega (Photo: author)

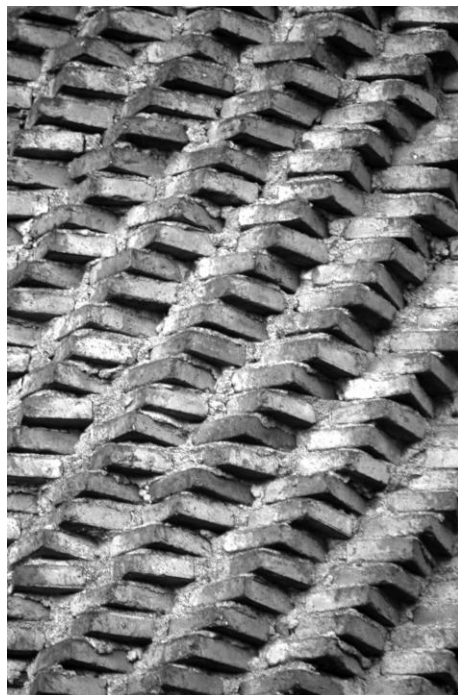

Figure 9. Detail of brickwork in Pelegrin Pipas chimney, Mora (Toledo) (Photo: author)

basin of the River Llobregat where there were good communications for the supply and distribution of manufactured products. A new owner Antonio Sedó (1842-1902), whose name was taken by the colony, began manufacturing once the Cairat canal had been completed, and its first water turbine began operating in 1881. The 180° helical square-section shaft of the chimney rises 21 metres from the plain, straight-side base to the crown which also lacks ornament. The ensemble is a forceful contrast of simple forms. Its construction, dating from before 1899 when it was first shown in a drawing of that date, is attributed to Amadeu Casals.¹⁰

A similar chimney built for a distillery at Sant Quintí de Mediona (1946-48) is of smaller diameter and height (around 12 metres) than the previous example and seems to have a more pronounced twist. (Fig. 11) This effect is achieved by the beginning of the twist at the foot of the shaft, not found elsewhere and particularly interesting since it is so reminiscent of the feet of the chimneys of the Casa Milà by Antoni Gaudí. Indeed, its constructor, Antonio Bou Massana (1902-1983) worked with Gaudí on the construction of a building in Mallorca Street, and on the Sagrada Família in Barcelona. The four initial



Figure 10. View of the Colonia Sedo square section chimney, Esparreguera, 1881 (Barcelona) (Photo: Ignasi Esquerra)



Figure 11. Distillery chimney by A. Bou Massana, Sant Quinti de Mediona, Barcelona, 1948 (Photo: Bou family archive)

corners which twist are not the ones that form the shaft, as is the case in one more Gaudí example in the columns of Santa Coloma de Cervello crypt.

A postcard from the year 1930 confirms the earlier existence of another square helical chimney, now demolished, with a twist of 540° around the axis, built for the textile firm of A. Bianchini & Co., Engineer, in the Poblenou of Barcelona. The dates of neither the construction nor the demolition are known, although the factory was abandoned in 1971.

The twist of a chimney becomes singularly sculptural when the cross section is octagonal. A fine example is to be found in the city of Valencia where the paper industrialist Luis Layana Alsina (1859–1918) built the 180° twisted chimney for his paper factory (Fig. 12), basing his own design on the columns of the unique, fifteenth-century silk trade centre, La Lonja de la Seda in Valencia, and the octagonal, gothic bell tower of Miguelete also in Valencia. This chimney, close to the City of the Sciences designed by the Valencian architect Santiago Calatrava (b.1951), served as an inspiration for another of Calatrava's creations – the Turning Torso Tower in Malmo (Sweden).



Figure 12. Industrial chimney of paper factory Layana, Valencia, 1903 (Photo: author)

Although this chimney is dated as 1903, the date found in the first application for permission to build¹¹ for the construction of a few shops in the Peñarrocha Street, adjacent to the Hermitage of Ave Maria in Valencia, there is no mention of the chimney, in this or the subsequent documents relating to the enlargements of 1904 and 1914. It seems most likely that its builder was Manuel García Sierra and Navarro, because the firm carried out all the construction works for this company.

The 25-metre high chimney consists of a powerful base of square cross section with a slight inclination, and a podium which is currently hidden under a layer of plaster that hides its true character. Above the cornice of the base, with stepped modillions (Fig. 13), the transition from the square base to the octagonal shaft creates an elegant series of curved surfaces.¹² The chimney, taller than a five-storey building, is now located in a pedestrian street with little traffic. This allows the chimney to be seen from the most important and visited places of the surrounding area. (Fig. 14)



Figure 13. Detail of the corner with modillions in Layana chimney, Valencia (Photo: author)



Figure 14. View Layana chimney and the City of Arts and Sciences, Valencia (Photo: author)

It seems clear that the Layana chimney was the inspiration for a similar 180° twisted chimney located in Alzira, in the province of Valencia. It dates from 1913 and, according to the metal lettering on the shaft of the chimney, was built by La Constructora company of masons. (Fig. 15) As with several other examples, the kiln belonging to this chimney has been demolished, leaving the chimney to form a central feature, almost a sculptural piece, in a public square in front of a residential area at the entrance of the town of Alzira. (Fig. 16)

The feature that unites this chimney, and that at Layana factory, is the use of bull-nose header bricks in the circular portion of the corners detail. At the paper factory these bricks have a number of angled grooves which, when viewed continuously upwards, give this corner the appearance of a thick rope (Fig. 17), and in this case simplifies the



Figure 15. Detail of shaft and registration of chimney La Constructora Society, Alzira, (Valencia), 1913 (Photo: author)

surface while keeping it completely smooth. The base, which serves as a podium, is octagonal like the shaft, so there is no need of a transition surface between the two. The dark colour of the mouldings in the cornice of the base highlights the junction and contrasts with the alternating red and green in each of the simulated cords that form the corner pieces. Its constructor, Agustín Goig Palomares (b.1878), was the first of a generation of constructors – brother, sons and nephews – that created a legacy of octagonal chimneys extending throughout Spain and its former colonies in North Africa.¹³ (Fig. 18)



Figure 16. Chimney La Constructora by Agustin Goig, surrounded by residential buildings, Alzira (Valencia) (Photo: author)



Figure 17. Detail corner cord paper chimney Layana, Valencia (Photo: author)



Figure 19. Cooperativa vínico- alcoholera Villenense chimney, Villena (Alicante), 1926 (Photo: author)



Figure 20. Chimney at Sanroma Mill (Baix de Monterol Mill), Reus (Tarragona) (Photo: Luis Rando & Lorena Escribano)

Perhaps the last chimney to mention with a helical form was that built for the Antonio Fábregas Mompeó distillery in 1964 at Tomelloso (in Ciudad Real). (Fig. 21) Its author, Antonio Jareño Herreros (b.1932), dared to exceed 40 metres in height using a combination of red and yellow bricks, following the examples given in the nineteenth century manuals, forming a series of diamonds in the base, and using red bricks to highlight the corners of the shaft and highlight the 315° rotation of the octagonal shaft. The shape of the bulb crown was a characteristic of this builder. (Fig. 22)

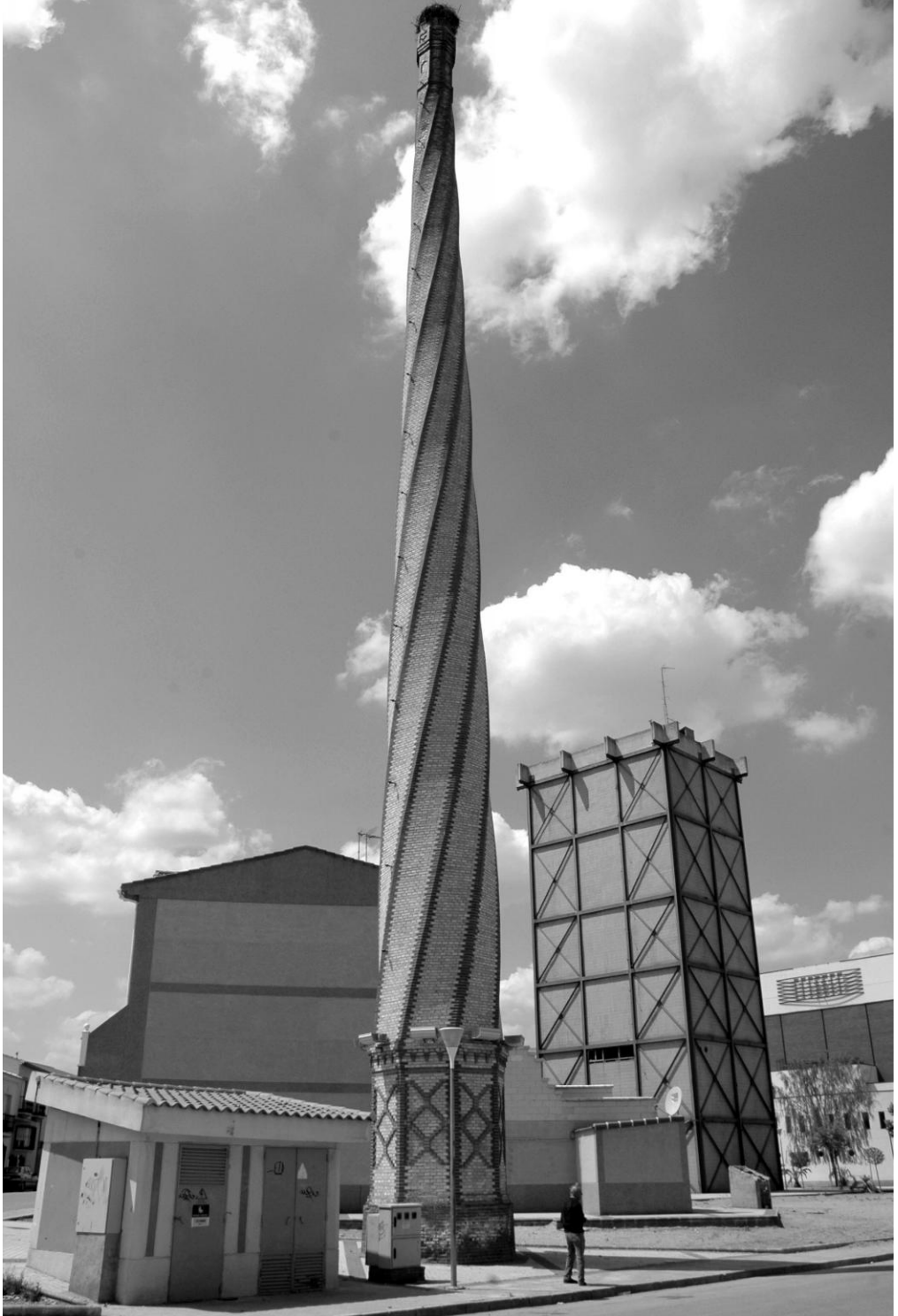

Figure 21. Chimney at the Bodega Antonio Fabregas Mompeo, built by A. Jareño, Tomelloso (Ciudad Real), 1964 (Photo: author)



*Figure 22. Detail of the intersection of the shaft and crown of the chimney, Tomelloso (Ciudad Real)
(Photo: author)*

Multidirectional helical twists

A chimney with a simpler geometry – straight-twist-straight – at the Martinet Mill at Paterna (in Valencia) introduces us to bidirectional helical twist. (Fig. 23) Its cornice of stepped modillions is reminiscent of the chimney at the Layana factory (Fig. 13) and was built at about the same time, in the first decade of the twentieth century. It employs the same understated way of working the corner without using a brick to highlight it. (Fig. 24) Unlike the Layana chimney, the crown is decorated with small



Figure 23. Chimney Martinet Mill, Paterna (Valencia) (Photo: author)



Figure 24. View of the cornice corner of the Martinet Mill chimney, Paterna (Valencia) (Photo: author)

crossed arches, all made with standard bricks. This chimney at the Martinet Mill achieves the reversal of twist within a height of just 15 m and does so more smoothly and elegantly than the next example.

The remarkable chimney built for the ceramic brick kiln of Roc or José Maria Granell at Alfara del Patriarca (in Valencia) at the very beginning of the 20th century¹⁶ has a unique helical octagonal shaft whose direction of twist changes (Fig. 25); equally unprecedented is the gradual transition of cross-section at the junction between the base and the shaft. (Fig. 26) Although it suffered a reduction in height in a recent restoration in 1999, it does retain the beauty of its



Figure 25. Double-twist shaft of Jose M. Granell ceramic kiln chimney, Alfara del Patriarca (Valencia) c.1910 (Photo: author)



Figure 26. The base of Jose M. Granell ceramic kiln, Alfara del Patriarca (Valencia) (Photo: author)

multiple vertical rotation. Having lost its original function it has become a meeting point and an area of public realm much used by students, staff and visitors of a private University, CEU San Pablo. (Fig. 27)



Figure 27. As a sculpture the helical chimney of Jose M. Granell ceramic kiln serves of meeting point for the students of the private university of CEU San Pablo, Alfara del Patriarca (Valencia) (Photo: author)

Helical chimneys elsewhere

The industrial chimneys that were portrayed in the first treatises dedicated to brick buildings in the 19th century generally had circular and octagonal section shafts. Their ornamentation was produced by a change of colour of the brick, and occasionally by highlighting it on the work of factory, especially in the case of the crown. An illustration from “*La Brique Ordinaire*”, published in 1878, shows how a chimney appears with darker parallel diagonal bands created using the colour of the bricks.¹⁷ (Fig. 28) This was realised in a chimney constructed in the Australian goldfields (Victoria) by Joseph Pickles (1823-97).¹⁸ The helical pattern was created using blue, red and white bricks.

Although helical brick chimneys do seem to be a largely Spanish phenomenon, some examples are found in other countries. One example is the fine 56-metre chimney at the Carlsberg Brewery in Copenhagen, Denmark (1900), designed by architect Vilhelm Dahlerup (1836–1907) and built by P.S. Beckmann.¹⁹ (Fig. 29) Its decoration is achieved partly in the use of two materials – red



Figure 29. Chimney at Carlsberg Brewery, Copenhagen, Denmark, 1900. (Photo: Diego Peris)

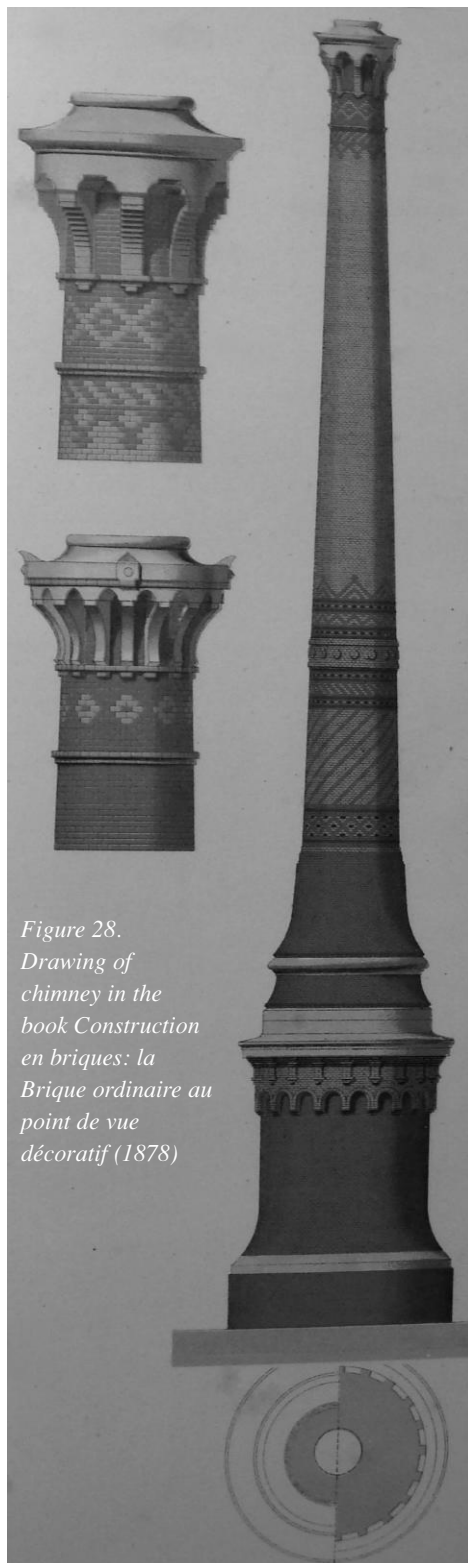

Figure 28. Drawing of chimney in the book *Construction en briques: la Brique ordinaire au point de vue décoratif* (1878)

brick and granite - and also by the use of floral motifs and even gargoyles. The helical twist of only about 90° in the main shaft of the chimney is achieved in relief using bricks that protrude about 50mm from the surface of the shaft.

A way to construct helical chimneys

The builders of helical chimneys no doubt developed a variety of different ways to construct their brickwork helices. The chimney builder Antonio Jareño, who was born in 1938, invented his own instrument to build the octagonal helical chimney for the distillery in Tomelloso.²⁰ (Fig.20) The instrument consists of two metal tubes each about 25mm in diameter, a vertical guide and a radial arm, joined at right angles. On the radial arm there is a moveable angle piece (the “corner locator”) that could be clamped in different positions, according to the changing radius of the chimney at different heights. (Figs 30-31). The inventor of this tool explained its method of use as follows:

“Two wooden planks, each with a circular hole of the same diameter as the tube, are supported by a scaffolding structure, one about 50 cm above the other, so that the two holes align with the central axis of the chimney, and verified with a plumb line. These planks located the setting-out tool vertically and allowed it to be raised incrementally after every 6 or 7 courses of brickwork had been laid.

To begin, the moulded corner pieces were laid in position at the corners of the octagon, and then the intermediate bricks were placed to complete the first course of bricks. The radial arm was rotated to set



Figure 30. Antonio Jareño showing his invention for setting out helical octagonal chimneys (Photo: author)



Figure 31. Detail of the sliding part of the instrument to build helical chimneys (Photo: author)

the position of the corner locator at the correct radius, and the position of the offset pin was clamped using the clamping screw which would define the rotational offset from one brick course to the next, and hence define the angle of the helix. First the offset was calculated at the mid height of the chimney, say 2cm, to give the right angle of twist for the helix. To take account of the larger diameter of the chimney at the base, the amount of offset had to be increased by a few millimetres, and this was progressively reduced to 2cm at mid height, and correspondingly towards at the top.

The second course was then begun by placing the corner bricks from the outside of the chimney against the angle piece of the tool to form the 135° corner of the octagon, with the necessary rotational offset from the corner of the course below. The remaining seven corners were laid, and the bricks between them were then laid to complete the course.

After seven or eight courses of brickwork, the setting out tool had to be removed and the scaffolding and timber planks re-erected approximately 50 cm higher, and the axial alignment checked again with the plumb line. Then the tool was refitted and the next few courses were laid.

All this while, the radius at which the corner locator was fixed on the radial arm was reduced by about 1 cm every 6 or 7 courses to create the 2% inclination of the chimney wall. And, as the radius was gradually reduced, so the rotational offset between one course and the next had to be reduced to maintain the same angle of the helix. These settings let you control the angle of the helix, and the same system could be used for helices made with other polygons, such as a hexagon.”

Reasons for a helical Chimney

Several different reasons have been suggested for making chimneys with a helical form to the shaft. However, only one has suggested there was a functional purpose to the helix. As mentioned above (see endnote 15) Gaudí had noted that, when it rises from a fire, smoke naturally follows a helical path and he argued that making the shaft helical would improve their effectiveness. He gave this as the reason for the form of his chimneys at Casa Milà in Barcelona. Antonio Bou, who built the chimney for the distillery at Sant Quintí de Mediona in the late 1940s (Fig. 11) was one of several Catalan chimney builders who worked with Gaudí and were no doubt influenced by his idea.

Generally, however, the helical form seems to have been used for aesthetic expression, as well as showing off the builder's construction skills. Those chimneys constructed around the turn of the 20th century were influenced by the organic movement of Modernism. The Valentian industrialist Layana was influenced not only by the new style but also by two monumental buildings in Valencia, as already explained. It was probably the builders of the chimneys themselves who brought the stylistic ideas from one project to the next, rather than a conscious decision by the owner of a factory to build in a certain style.

Finally, Antonio Jareño, builder of the helical chimney in Tomelloso and inventor of the tool to help construct it, said that he had been inspired by the chimney constructed in 1942 by Pedro Alcañiz for Aníbal Arenas in Socuéllamos (see section *The Helical Appearance*, above) and by the description of the chimneys in Alzira (Fig. 16) and Villena (Fig.19), built by Jose Goig (nephew of Agustin Goig mentioned earlier) who worked for many years in Tomelloso where spectacular chimneys were built for the most famous wineries.

It would seem that it is nothing more than a curious coincidence that many small steel industrial chimneys built in modern times have helical fins fitted to the shaft in order to disturb the airflow and prevent the chimneys being caused to vibrate.

The protection of industrial chimneys in Spain

There are now two laws protecting the Industrial Heritage in Spain, the Spanish Historical Heritage Act, 1985²¹ and the National Industrial Heritage Act, 2001.

Thirteen of Spain's autonomous regions, Andalusia, Aragon, Asturias, Canary Islands, Castilla La Mancha, Castilla Leon, Catalonia, Extremadura, Balearic Islands, La Rioja, Murcia, Navarra and Valencia, have heritage legislation that makes specific reference to industrial archaeology or architecture. To date, however, only in the Valencian act²² is there an explicit reference to the brick smokestacks. The Fifth Additional Provision of the Act: Legal Recognition of Locally Relevant Works²³, makes specific reference to:

“the following categories of architectural elements: Traditional historic centres, well known under the planning legislation, water wells, ice houses, industrial chimneys of brick built before 1940, old windmills, workers accommodation in the orchards of Valencia, and auction and community halls before the nineteenth century.”

A chimney with no known date of construction can only be protected under the category of “local relevance”. In 1999, within the campaign “Europe, a common heritage”, the Council of Europe launched a project to raise awareness of industrial heritage not only with regard to the physical remains, but also as a way of life. The Spanish Ministry of Culture participated actively in this project, and the Spanish Historical Heritage Institute is actively drafting a National Industrial Heritage Plan.

In the latest revision of the Plan, March 2011, in addition to defining what is meant by Industrial Heritage, the National Industrial Heritage Plan proposes a comprehensive approach considering industrial manufacturing centres, adding isolated elements, outside the context of industrial installations, as is the case for chimneys, and includes the wider industrial landscape and networks for water transport, energy, goods, and communications.

Taken together, these measures will surely improve the likelihood that chimneys of recognised merit and significance will be preserved for future generations.

Conclusion

The places where the first helical industrial chimneys were built are strongly related to the birth and establishment of the European New Style, Modernism, in Spain. This is also why the chimneys were first built around the beginning of the 20th century. Nevertheless, the design of these chimneys seems largely to have originated with the firms who built them, with little formal influence from professional architects. The helical rotation of the shaft can be real or imitation, achieved through the use of ceramic pieces or painting. The angles of the twist may be uniform or change along the height of the shaft. Most of all, they are an expression of the craft skills of the builders and the materials they worked with.

While many chimneys from this period have been lost, many still survive. From a practical point of view, they have the benefit over other old industrial buildings that they occupy relatively little land and are less vulnerable to destruction at a time when former industrial land has been the victim of much opportunistic speculation.

In a growing number of cases, the role of a prominent chimney in the urban landscape is being recognised. Chimneys have found a new role, similar to obelisks, as giving character to public spaces while also maintaining a permanent memory of an industrial age, now largely lost.

Author

The author lectures in construction materials and building construction at the Polytechnic University of Valencia. She has recently completed her doctoral thesis on industrial brick chimneys, and has published several papers on the subject. The author would appreciate any information about the construction of industrial chimneys, both helical and others.

Contact details:

Dr Gracia Lopez-Patiño, Assistant Professor of Construction Materials
Department of Architectural Construction
Universidad Politécnica Valencia
Camino de Vera, s/n
46022 Valencia, Spain
E mail: glopez@csa.upv.es ; chimeneas.industriales.ladrillo@gmail.com

References

1. James Douet, *Going up in Smoke: The History of the Industrial Chimney*. London: Victorian Society, 1988.
2. W. Pickles, *Our Grimy Heritage: a fully illustrated study of the factory chimney in Britain*. Open Gate Press, 1971.
3. Louis Degen, *Les constructions en briques*. Barcelona: J.M. Fabre, 1880. First published in 1860.
4. Robert Rawlinson, *Designs for Factory, Furnace and other Tall Chimney Shafts*. Kell, 1859.
5. G. Braet, *Note sur la construction et la stabilité des cheminées en maçonnerie*. Brussels, 1883.
6. Robert M. Bancroft and Francis J. Bancroft, *Tall chimney construction: a practical treatise on the construction of tall chimney shafts*. Manchester: Calvertin, 1885.
7. W. Armstrong, *Chimneys, Furnaces and Fireplaces*. London, 1885.
8. A picture, dated in 1935, in a daily magazine shows the factory with the chimney.
9. a place where the rice was separated from husk.
10. The colony Sedó in Esparreguera. Revista cultural property no. 7. 2007 The Director Plan of the colony Can Sedo can be followed in the following link, as well as photographs of the chimney <http://www.Vilanova-Moya.com/PDF/ut8.pdf> (accessed August 20th, 2012)
11. Municipal Archives of Valencia PU year 1903 box 10 exp 318.
12. Gracia Lopez Patiño, Proceedings of the VII National Congress of History of Construction. Madrid: Instituto Juan de Herrera, 2011.
13. Gracia Lopez Patiño, Proceedings of the V National Congress of History of Construction. Madrid: Instituto Juan de Herrera, 2007.
14. <http://www.alicantevivo.org/2007/11/Las-chimeneas-de-ladrillo-de-la.html> (accessed August 20th, 2012)
15. <http://www.ctv.es/USERS/ags/GAUDI-pedreira.htm> (accessed 20 August 2012)
16. An archeological study of the materials of construction reveals the brick dimensions and mortar used for its construction dated after 1900 and before 1920. V. Algarra, P. Berrocal, *Análisis arqueológico industrial del Rajolar de Josep Maria Granell d'Alfara del Patriarca* Proceedings of the I Congress of Horta Nord studies, 1997
17. J. Lacroux, C. Détain & J.-A. Léveil, *Construction en briques : la Brique ordinaire au point de vue décoratif ... 2 vols*, Paris: Ducher, 1878. Reprinted as *Architectural Brickwork*, with an introduction by David Jenkins, London: Studio Editions, 1992.

18. See picture in http://adambalic.typepad.com/the_art_and_mystery_of_fo/2008/01/oatcakes.html (accessed February 22nd, 2013)
19. As a brief inscription shows on the stone of the chimney according to Dorothee Zanker von Meyer, *Die bauten von JC. Und Carl Jacobsen: zur Bautätigkeit einer Industriellen familie in Dänemark*. DL. Kunstverlag, 1982
20. Interview by the author with Antonio Jareño.
21. Ley 16/1985, de 25 de junio, de Patrimonio Histórico Español.
22. Ley 4/ 1998, de 11 de junio, del Patrimonio Cultural Valenciano y Ley 5/ 2007, de 9 de febrero, modificación ley 4/1998.
23. Bien de Relevancia Local, BRL.