

Architectural Heritage and Photovoltaic Solar Panels: Regulatory Framework and Action Criteria in Navarra (Spain)

J.L. Franchez Apecechea^{1,*}

¹ Chief Architect of the Architectural Heritage Section of the General Directorate of Culture - Príncipe de Viana Institution, Government of Navarra, Pamplona, Spain, jfrancha@navarra.es

Topic: T1.3. Mechanisms of sustainability of vernacular architecture

How to cite: Franchez Apecechea, José Luis (2025). Architectural Heritage and Photovoltaic Solar Panels: Regulatory Framework and Action Criteria in Navarra (Spain). In C. Mileto, F. Vegas, A. Hueto-Escobar & S. Manzano-Fernández (Eds.) *Earthen and Vernacular Heritage: Conservation, Adaptive Reuse and Urban Regeneration*. September 10th – 12th, 2025, Valencia (Spain). edUPV.
<https://doi.org/10.4995/HERITAGE2025.2025.20381>

Abstract

Nowadays, there is an evident growing social demand for installing self-consumption photovoltaic solar panels on existing buildings. This reality often conflicts with the duty to protect and preserve our built cultural heritage, whose conservation is of public and social interest. And it is not only referring to monumental heritage, which holds the legal protection granted by its designation as a Cultural Heritage Asset, where any intervention is regulated and controlled, but also and especially to domestic architectural heritage: an entire collection of minor traditional architecture spread across our cities and towns, without a clear stylistic classification but of great environmental value due to its presence in the landscape, of which it is an essential and inseparable part. The installation of solar panels on the roofs of all these buildings can lead to a substantial modification of some landscapes and urban spaces that are part of the collective visual memory. It should be noted that this article constitutes, more than a proper scientific text in accordance with the objective of this conference, a reasoned exposition and evaluation of a real situation of conflict between the implementation of certain renewable energy installations in built cultural heritage—primarily photovoltaic solar installations—and the application of their legal protection regime and the duty of conservation.

Keywords: sustainability; energy rehabilitation; historic centers and buildings; architectural heritage; photovoltaic panels; renewable energy communities

1. Background

Part of the work as an architect at the General Directorate of Culture–Príncipe de Viana of the Government of Navarra consists of reviewing projects and projects and works related to interventions in protected architectural heritage of Navarra. The experience accumulated over the years and the methodology employed when preparing project reports on interventions in cultural heritage allow to outline some basic

criteria about the valuation and legal protection of heritage and its complex integration with certain facilities associated with the associated with the energetic rehabilitation of these buildings.

2. Introduction

Today, the social demand for energy rehabilitation of existing buildings is evident. This aspiration is legitimate and commendable

but, at times, difficult to reconcile with the duty to preserve our built cultural heritage, whose conservation is mandatory and of public and social interest.

It is clear that most energy consumption in the construction sector comes from the existing building stock, which is generally energy obsolete. A part of this built stock constitutes cultural architectural heritage, which has legal protection and, in some cases, conflicts with energy rehabilitation criteria.

And it is not only referring to monumental heritage, which holds the regulated legal protection granted by its designation as a Cultural Heritage Asset¹ (hereinafter BIC) (Ley Foral 14/2005, 2005), but also and especially to domestic architectural heritage—an entire set of minor traditional architecture scattered throughout our towns, without a clear stylistic classification but of great environmental value due to its presence in the landscape, of which it is an essential and inseparable part.

If the true goal is the sustainable development of society, it is necessary also preserve the historical construction constants that define the traditional architecture of many of towns. This task, in most cases, is difficult to reconcile with the installation of solar panels on rooftops. It does not seem advisable to impose the same requirements on all buildings indiscriminately, without considering the uniqueness of their historical and cultural context or their intrinsic architectural value.

While the goal of using renewable energy sources for self-consumption in buildings is legitimate, installing solar panels on the roofs of many buildings and historic districts that are part of cultural heritage is not always the right solution.

Some significant examples in Navarra that could be affected include towns such as Ziga in the Baztán Valley (Fig. 1), where traditional architecture maintains unique construction constants and integrates harmoniously into the natural landscape, or Ujué, with its cluster of buildings adapted to the topography of the hill crowned by the fortress church of Santa María. Also worth mentioning are the traditional farmhouses of the Navarrese mountains, whose beauty results from logical construction adapted to the natural environment, along with many other examples.



Fig. 1 – Ziga, a representative village in the Baztán Valley (Navarra from the sky. Santander Bank. 1997).

It is clear that if heritage interventions are guided exclusively by energy efficiency criteria, it will lose cultural values linked to the built legacy we have inherited. In my opinion, sustainable energy development must consider, in addition to energy efficiency principles, the historical construction constants that define the architecture of many of our towns and cities.

¹ It is one of the three special categories of protection assigned to cultural heritage assets by the Foral Law

14/2005 of November 22, on the Cultural Heritage of Navarra.

This task, in most cases, is difficult to reconcile with the visual and construction impact of installing solar panels on rooftops or thermal envelopes on historic buildings, which are fundamentally protected by two basic legislative frameworks.

3. Basic legislation

The basic legislation for protecting architectural heritage in Navarra comes from two jurisdictional areas: the Navarra Cultural Heritage Law and the Navarra Territorial and Urban Planning Law (Ley Foral 14/2005, 2005; Decreto Foral Legislativo 1/2017, 2017). Both legal frameworks establish various control and protection measures for listed and declared buildings within urban planning regulations. Additionally, another recent national-level law, though little known, also recognizes the value of built architecture. This is Law 9/2022 on Architectural Quality which aims to protect, promote, and disseminate architecture as a matter of general interest (Ley 9/2022, 2022). It is worth noting that this law states: "As a matter of general interest, architecture shall be subject to protection, promotion, and dissemination by all public authorities" and further establishes that "The Administration is responsible for protecting the values of built heritage and promoting its rehabilitation as a matter of general interest, as well as implementing exemplary public policies to achieve these objectives" (Ley 9/2022, 2022). It is evident that this general duty toward architecture extends even more so to built architecture of cultural value.

4. Sectoral legislation

To briefly review the legislation and regulations applicable to sustainable energy development in Navarra, one must look back to the implementation of the Spanish Technical Building Code (CTE) in 2006 (Real Decreto 314/2006, 2006), which mandated that part of the energy consumption in renovated buildings come from renewable energy sources, thus requiring

the installation of solar thermal collection systems on roofs (Real Decreto 314/2006, 2006). At that time, after analyzing the impact of this requirement on architectural heritage protection, the General Directorate of Culture- Príncipe de Viana Institution of the Government of Navarra issued several resolutions exempting certain buildings from the obligation to install solar panels on rooftops.

These exemptions were applied in varying degrees across five geographic areas of Navarra: the Pre-Pyrenean basins, the humid northwest of Navarra, La Ribera, the Pyrenean valleys, and central Navarra (Resolución 281/2007, 2007; Resolución 282/2007, 2007; Resolución 283/2007, 2007; Resolución 301/2007, 2007; Resolución 302/2007, 2007). These resolutions have since been incorporated into the urban planning regulations of municipalities that have approved plans since then.

4.1 The regional climate change law

If we move forward in time, also within the scope of Navarra, in 2022, the Government of Navarra approved the Regional Climate Change and Energy Transition Law. Among other provisions, this law establishes in Article 33.2 that:

Buildings for residential, industrial, commercial, and institutional use with more than 500 m² of roof area must install individual or shared photovoltaic systems covering at least 35% of their surface area on south, southeast, and southwest-facing roofs (Ley Foral 4/2022, 2022).

The law itself, however, in Article 39.1, mentions an exception for buildings of cultural value, considering the possibility of substituting the obligation to install solar panels in those buildings with a contract with energy providers that ensure more than 35% renewable energy. This, in my view, is a requirement that is difficult to justify. In any case, this law is pending further development through regulations that will define these obligations.

4.2 Energy Communities

It is interesting to bring into the discussion, as a means of reconciling the energy transition and the protection of built heritage, Regional Order 64/2022, issued by the Minister of Economic Development and Business, which establishes measures to promote energy communities in Navarra, with the aim of creating a favourable legal framework for their implementation (Ley Foral 4/2022, 2022). In many localities, photovoltaic panel installations, if there is interest and management capacity, could be considered through energy cooperatives, located in selected areas that integrate properly into the locality and do not harm its cultural and environmental values. This means community installations developed on land or on rooftops of buildings that do not have cultural or urban protection. The implementation of these energy communities represents an interesting alternative to consider in towns with protected historic centers, where their monumental designation, justified by their architectural and urban values, logically limits these types of installations.

5. Basic action criteria

The Architectural Heritage Section of the General Directorate of Culture- Principe de Viana Institution, in exercising its responsibilities, prepares impact reports on architectural heritage in two main areas related to renewable energies: The first refers to the installation of wind or photovoltaic parks in non-urban land, and the second concerns the authorization of thermal envelopes and photovoltaic panels on the rooftops of buildings cataloged in the municipal urban planning or located in protection areas of a BIC².

In the first case, as a general rule, most reports on wind and photovoltaic parks, given that they are located in non-urban areas and far from built-up areas, are usually favorable as long as they do not directly affect protected architectural heritage. This is the case of the monumental BIC surroundings, historical routes such as the Camino de Santiago, or cataloged buildings.

Another issue is the impact on archaeological heritage, especially regarding the routing of underground evacuation lines of photovoltaic solar parks, which falls under the Archaeology Section's jurisdiction³. This may impose more restrictions, as these lines could be located on land with potential archaeological value. And it is not appropriate to assess, because it is not within the competence of the Architectural Heritage Section, the impact on the natural landscape or the restriction of agricultural land use, which is limited by the occupation of land for these parks.

Regarding municipal urban planning, it is worth noting that the Architectural Heritage Section issues reports during the approval process of urban plans. Among other protection measures, it is reviewed that the regulations include the prohibition of authorizing the installation of solar panels on the rooftops of cataloged buildings when they are visible from streets or public spaces. This criterion also applies to all buildings that are part of historic centers declared as BIC, which in Navarra include Burguete, Estella, Olite, Pamplona, Puente La Reina (Fig. 2), Sangüesa, Santesteban, Tudela, and Viana, as well as the historic complex of Cerco de Artajona.

² These are reports issued by the technicians of the Architectural Heritage Section during the administrative approval process of the projects.

³ Section of Movable Assets, Archaeological Heritage, and Registry of the General Directorate of Culture - Prince of Viana Institution



Fig. 2 – Orthophoto of BIC historic center of Puente La Reina (Archive of the Principe de Viana Institution).

To properly assess the criteria described, it is appropriate to reflect on an essential consideration. Roofs are an integral part of cataloged buildings, contributing to their external appearance and architectural value. Sloped ceramic tile roofs are the traditional roofing solution in many old town centers in Navarra, particularly in most cataloged buildings in municipal urban planning regulations.

Photovoltaic panels do not align either materially or aesthetically with tile roofs—due to characteristics such as the glassy surface and color, the mounting structures and the inevitable aesthetic mismatch with roof slopes, especially considering that many roofs have triangular or trapezoidal shapes.

Since they are superimposed, they obscure the ceramic tile covering, which defines the appearance of protected buildings. For this reason, their installation on rooftops generates a negative visual impact on the preservation of their architectural value.

For these reasons, the Architectural Heritage Section considers photovoltaic installations inappropriate on cataloged buildings when they are visible, either from a distance or up close, from streets or public spaces (Fig. 3).

Nevertheless, it should be noted that certain exceptions to this general criterion have been accepted. Below, it is worth mentioning some recent examples.

In the case of protected surroundings of a BIC-listed building, the installation of photovoltaic panels has been authorized when the installation is placed on the ground within the surroundings and not on rooftops, ensuring no direct visual impact on the listed building. A concrete example is the photovoltaic installation carried out at the monastery of Leire, which is detailed below ⁴. The site chosen for the installation is one of the former orchards of the monastery, located southeast of the monumental monastic buildings, south of what was the path to the Fuente de las Vírgenes.

⁴ By Resolution 117/2024, of May 17, of the General Director of Culture-Principe de Viana Institution, the works for the installation of a self-consumption photovoltaic system at the Monastery of San Salvador de Leyre were awarded to the company Construcciones Leache S.L., according to the project

drafted by the technicians of the Architectural Heritage Section, as part of the execution of project C14.I04.subproject 3 of the 'Recovery, Transformation, and Resilience Plan - Funded by the European Union - Next Generation EU.' The works were completed in May 2025.



Fig. 3 – *Negative visual impact due to the installation of solar panels on a tile roof.* (Archive Architectural Heritage Section. General Directorate of Culture–Príncipe de Viana Institution).

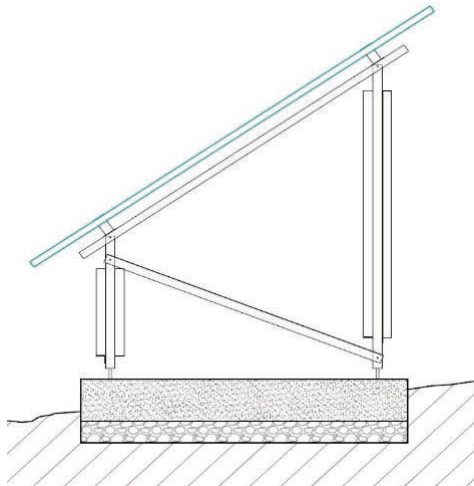

Fig. 4 – *Cross-section of the installed photovoltaic modules* (Archive, Architectural Heritage Section. General Directorate of Culture–Príncipe de Viana Institution).

The land was partially covered by a small wooded area planted by the community a few decades ago. The location was selected based on certain conditions. On one hand, there were no unfavorable visual impacts nearby from the monastery and its urbanization concerning the installation. There were also no distant visual impacts from the slopes to the south, southeast, and southwest, nor from the upper slope and the ridge of the mountain range. On the other hand, the topography of the land, with a slight slope towards the south, was favorable.

Lastly, the chosen area is integrated into the enclosure of the monastic community and the distance from the monastery's transformation center was considered adequate. The land chosen for the installation had traditionally been used as an orchard.

The installation was promoted by the General Directorate of Culture–Príncipe de Viana Institution, as it is a photovoltaic installation linked to the use and operation of the monastery, since its goal is to generate electricity for the monastery's self-supply. The installation consists of 580 photovoltaic modules with a total capacity of 261 kW. The modules are oriented south with a 35° tilt and are grouped into tables arranged longitudinally in an east-west direction, forming intermediate passage aisles between rows (Figs. 4–6).

Another case of exceptionality is that of the historic center of Tudela, declared a Cultural Asset of Heritage (BIC), for which a modification of the PEPRI (Special Plan for the Protection and Renovation of the Historic Center) has been favorably reported, allowing the installation of photovoltaic panels on the roofs of buildings located in the peripheral areas of the declared historic center, that is, former suburbs or orchards outside the medieval walled enclosure - except for the cataloged properties located in these areas. The urban planning of these areas does not follow the usual parameters of the historic center, and detailed regulations have been established regarding co-planarity with the roof slopes, limiting the surface area to a percentage of the slope's surface and specifying minimum distances of separation from the eaves and ridgelines of the pitched roofs.

The new regulation establishes a framework, including specific guidelines on orientation, coplanarity, surface area, and required distances from the eaves and ridgelines, in order to reduce the unfavorable visual impact. Specifically, the approved regulation stipulates that:

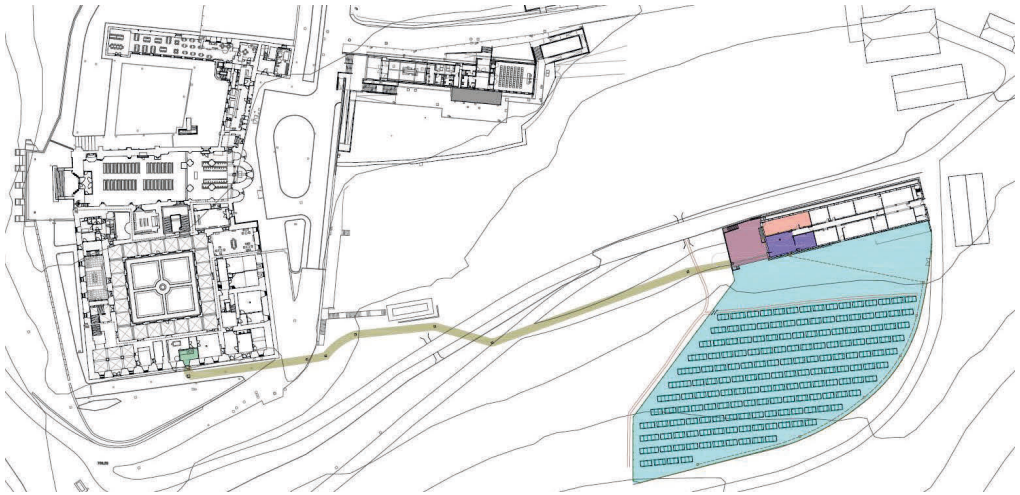

Fig. 5 – Leyre monastery. Plan of the complex showing the scope of action: in blue, solar orchard with photovoltaic modules; in green, connection conduit to the monastery's transformer room (Archive, Architectural Heritage Section. General Directorate of Culture–Príncipe de Viana Institution).

1. Photovoltaic installations on rooftops must be located on the sloped sections of roofs oriented towards the south ($\pm 30^\circ$ deviation). They must consist of flat, non-reflective panels fully integrated into the roof slope, maintaining its plane and orientation. Roof tiles with photovoltaic cells are permitted.
2. The surface area of solar panels must be equal to or less than 40% of the surface area of the roof slope where they are installed, and they must always be placed at a distance of at least two meters from the edge of the eaves.
3. No devices, mechanisms, and/or auxiliary elements of the solar energy production systems may be installed on the external façades of buildings. They also may not be placed in roof areas visible from public roads or spaces.

6. Conclusions

It is essential when assessing the suitability of energy rehabilitation installations in protected buildings to consider: The uniqueness of the historical and cultural context in which they are placed and the intrinsic architectural value of the

buildings. Although the goal of utilizing renewable energy sources in buildings is commendable, certain installations are currently not appropriate for historic buildings and town centers that are part of cultural heritage. It is evident that technological advancements in these installations are on the horizon, and within a few years, new solutions may emerge that better align with the regulatory framework for protecting these buildings. These developments could help reconcile the so-called energy transition with the preservation of the architectural values of buildings that form part of cultural heritage.



Fig. 6 – Leyre monastery. View of the photovoltaic installation located in an area of former monastery orchards. In the background, the monastic complex. (Archive, Architectural Heritage Section. General Directorate of Culture–Príncipe de Viana Institution).

An example might be the technological development of photovoltaic solar tiles, although still conditioned by the improvement of their chromatic appearance and energy efficiency. Their implementation would reduce the current visual impact of photovoltaic panels and their anchoring systems on roofs, assuming that the roof is the part of the building that is most frequently renewed and, therefore, does not usually preserve the original historical covering; we would not be talking about solar panels overlaid on a roof, but about solar tile roofs. In any case, time will tell, but in the meantime, caution is advised.

References

- Ley Foral 14/2005, de 22 de noviembre, del Patrimonio Cultural de Navarra. *Boletín Oficial del Estado*, 304, 21 december 2005. <https://www.boe.es/eli/es-nc/lf/2005/11/22/14/>
- Decreto Foral Legislativo 1/2017, de 26 de julio, por el que se aprueba el Texto Refundido de la Ley Foral de Ordenación del Territorio y Urbanismo. *Boletín Oficial del Estado*, 272, 9 november 2017. <https://www.boe.es/eli/es-nc/df/2017/07/26/1/>
- Ley 9/2022, de 14 de junio, de Calidad de la Arquitectura. *Boletín Oficial del Estado*, 142, 15 june 2022. <https://www.boe.es/eli/es/1/2022/06/14/9/>
- Real Decreto 314/2006, de 17 de marzo, por el que se aprueba el Código Técnico de la Edificación. *Boletín Oficial del Estado*, 74, 28 march 2006. <https://www.boe.es/eli/es/rd/2006/03/17/314>
- Resolución 301/2007, de 17 de mayo, de la Directora General de Cultura, por la que se excluye del ámbito de aplicación de los Documentos Básicos HE4 y HE5 del Código Técnico de la Edificación a las localidades de las cuencas prepirenaicas de Navarra. *Boletín Oficial de Navarra*, 80, 29 june 2007. <https://bon.navarra.es/es/anuncio/-/texto/2007/80/28>
- Resolución 283/2007, de 11 de mayo, de la Directora General de Cultura, por la que se excluye del ámbito de aplicación de los Documentos Básicos HE4 y HE5 del Código Técnico de la Edificación a las localidades de la Navarra húmeda del noroeste. *Boletín Oficial de Navarra*, 80, 29 june 2007. <https://bon.navarra.es/es/anuncio/-/texto/2007/80/27>
- Resolución 302/2007, de 17 de mayo, de la Directora General de Cultura, por la que se excluye del ámbito de aplicación de los Documentos Básicos HE4 y HE5 del Código Técnico de la Edificación a las localidades de la Ribera de Navarra. *Boletín Oficial de Navarra*, 79, 27 june 2007. <https://bon.navarra.es/es/anuncio/-/texto/2007/79/27>
- Resolución 281/2007, de 11 de mayo, de la Directora General de Cultura, por la que se excluye del ámbito de aplicación de los Documentos Básicos HE4 y HE5 del Código Técnico de la Edificación a las localidades de los valles pirenaicos y las cuencas prepirenaicas de Navarra. *Boletín Oficial de Navarra*, 80, 29 june 2007. <https://bon.navarra.es/es/anuncio/-/texto/2007/80/26>
- Resolución 282/2007, de 11 de mayo, de la Directora General de Cultura, por la que se excluye del ámbito de aplicación de los Documentos Básicos HE4 y HE5 del Código Técnico de la Edificación a las localidades de la Navarra media. *Boletín Oficial de Navarra*, 79, 27 june 2007. <https://bon.navarra.es/es/anuncio/-/texto/2007/79/26>
- Ley Foral 4/2022, de 22 de marzo, de Cambio Climático y Transición Energética. *Boletín Oficial del Estado*, 93, 19 april 2022. <https://www.boe.es/eli/es-nc/lf/2022/03/22/4/>
- Orden Foral 64/2022, de 21 de octubre, del consejero de Desarrollo Económico y Empresarial, por la que se establecen medidas de fomento de las comunidades energéticas en Navarra. *Boletín Oficial de Navarra*, 219, 15 november 2022. <https://bon.navarra.es/es/anuncio/-/texto/2022/226/0>