



## Hardware Article

# Low-cost automated GPS, electrical conductivity and temperature sensing device (EC + T Track) and Android platform for water quality monitoring campaigns

Pablo Blanco-Gómez <sup>a,\*</sup>, José Luis Jiménez-García <sup>b</sup>, Jose M. Cecilia <sup>c</sup>

<sup>a</sup> Vielca Ingenieros, S.A, Avda. Aragón, 17, 46010 Valencia, Spain

<sup>b</sup> Vielca Medio Ambiente, S.L, Avda. Aragón, 17, 46010 Valencia, Spain

<sup>c</sup> DISCA, Universitat Politècnica de Valencia, Camino de Vera, s/n, Valencia 46011, Spain



## ARTICLE INFO

## Article history:

Received 8 August 2022

Received in revised form 6 October 2022

Accepted 26 November 2022

## Keywords:

Water quality monitoring

Marine IoT

Android App

## ABSTRACT

Environmental and water quality monitoring are of utmost interest in a context where land use changes, uncontrolled agricultural practices, human settlements, tourism and other activities affect a watershed and condition the usage of their surface waters. Such is the case of Mar Menor lagoon in Southeast of Spain, where the EU H2020 SMARTLAGOON project stands and is implementing an intelligent environmental infrastructure and modelling that will let the construction of a digital twin of the lagoon. Performing environmental monitoring is expensive and the number of sampling locations is typically limited by the budget. For this reason, we have developed a low-cost monitoring system that can be integrated in a small-sized buoy and attached to fishing and recreational boats allowing citizens to gather water quality information – i.e. electrical conductivity and temperature – with the use of their smartphones. The usage of such devices leads to key stakeholder engagement and citizen science activities that could enrich and ease the data gathering process.

© 2022 The Authors. Published by Elsevier Ltd. This is an open access article under the CC BY-NC-ND license (<http://creativecommons.org/licenses/by-nc-nd/4.0/>).

## Specifications table

Hardware name	Low-cost Electrical Conductivity and Temperature sensing device for monitoring campaigns
Subject area	<ul style="list-style-type: none"> <li>• Environmental, planetary and agricultural sciences</li> </ul>
Hardware type	<ul style="list-style-type: none"> <li>• Field measurements and sensors</li> </ul>
Closest commercial analog	Water Quality Multi-parameter sensor
Open source license	<a href="https://creativecommons.org/licenses/by/4.0/">https://creativecommons.org/licenses/by/4.0/</a>
Cost of hardware	190 €
Source file repository	<a href="https://doi.org/10.5281/zenodo.6674534">https://doi.org/10.5281/zenodo.6674534</a>

\* Corresponding author.

E-mail address: [pablo.b@vielca.com](mailto:pablo.b@vielca.com) (P. Blanco-Gómez).

## Hardware in context

Water quality monitoring is a field of great scientific interest in inland and coastal ecosystems [1–5]. In both contexts, gathering information becomes crucial for effective monitoring, on both spatial and temporal scales [5]. As population expands, humankind pressures, like agricultural activities, farming or tourism, may lead to potential risks to water bodies that has become a primary concern for water managers and researchers [5]. Data availability allow the diagnosis of the ecosystems, affect the knowledge of the causes of the referred problems, and enhance environmental research [1,3].

Depending on the sampling frequency and the processing capacity, collecting data manually can become a time-consuming and labour-intensive task. Manual sampling can also become expensive when compared to automated data collection systems connected to environmental sensors [1–4].

Sea surface salinity reflects a fundamental property in transition waters and varies considerably in space and time [6]. It is typically used for predicting coastal physical processes (e.g., mixing between freshwater and marine systems), intensity, frequency and duration of salinity stratification events, and current circulation patterns.

Automated water sampling and water quality monitoring has been described in recent times in similar contexts, as referred above, in particular: Xu et al. (2019) [2] reviewed the availability of IoT monitoring devices existing in the marine environment. They reported upon 37 experiments that can be classified in different areas, including 8 experiments related with water quality monitoring. Most of them measured either electrical conductivity or salinity, but they were deployed in a static buoy, gathering information in a single point. Albaladejo et al. (2012) defined a low-cost autonomous buoy system that could be deployed in different places and gather time series of pressure and temperature point-data. One of the strengths highlighted of their system is the ease of addition of new sensors. Ryu (2022) [3] equipped an unmanned aircraft system (UAS) with an IoT device for water sampling and continuous measurement of water quality parameters such as pH, temperature, electrical conductivity and dissolved oxygen. While the UAS system allows the acquisition of samples in non-readily accessible places, the autonomy of the aircraft battery limits the measurement capacity of the system, presenting track records of a maximum of 20–30 min. Similar battery limitations were present in Jo et al. (2019) [4] where an unmanned surface vehicle (USV) was designed for water quality monitoring. The system, provided with a GPS for global positioning, measured pH, turbidity and temperature, but used a unique power source, including displacements. Finally, Adamo et al. (2014) [7] presented a smart water quality monitoring system for measuring chlorophyll, turbidity, temperature and electrical conductivity, that could be attached to a buoy and send data via radio or GPRS technologies. In addition to the lack of georeferencing information, no power consumption values were showed in the paper.

EC + T track project consists of a low-cost prototype for continuous measuring electrical conductivity and temperature in order to know the water salinity content, that can be attached to a marine vehicle and record the position of the measurements, allowing also spatial analysis. Salinity gradient is one of the major drivers of marine currents [8] and its measurement could help scientist and researchers to better understand the hydrodynamic and biogeochemical processes occurring in transition waters and coastal lagoons.

The project can be replicated and attached to different floating vehicles, easing data gathering and allowing the engagement and participation of different stakeholders through citizen science activities.

## Hardware description

A prototype of low-cost marine IoT system has been implemented to carry out real-time water quality measurements (i.e. Electrical Conductivity (EC) and Temperature (T)). It is equipped with a floating buoy and can be attached to a moving platform like a boat. Data initialization and device control is integrated in a smartphone App.

The described apparatus consists of an electronics and power core, protected inside a waterproof enclosure – built with PVC piping materials – with an orifice for two wired sensors – i.e. EC and T sensors – that, at the same time, are enclosed in a 3D-printed protection for water velocity attenuation and measurement.

The electronics include two lines connected to the power bank: (1) A boost step-up unit connected to the power bank, to enhance the power supply needs to 13.3 V (i.e. two 5 V and one 3.3 V pins are used) connected to a Hw-131 Board for power supply control; (1.1) A DFR0300-H sensor [9]; and (1.2) a DFR0300-H sensor [10] for, respectively, EC and T measurements; (2) An Arduino Mega (AM) [11] controller with: (2.1) a BN-180 GPS unit pinned for georeferencing measurements; and (2.2) a HC-05 Bluetooth (BT) [12] device for connection and communication with the smartphone. Fig. 1 shows the physical structure and main connections of the EC + T track package.

After a first testing campaign, the floating capacity and waterproofing of the buoy was contrasted in shallow water conditions but the water velocity incidence and environmental exposure of the sensors suggested the use of a protection cap. To improve this, a 3D-printed protection was designed and constructed, being able to protect the sensors and pacify the water as expected.

The advantages of EC + T Track are twofold. First, the low-cost version of a marine IoT system for real-time water quality measurements provides an opportunity to replicate and incorporate to several marine media – e.g. ports, buoys, boats, aquatic bikes, kayaks – and improve the scientific knowledge of EC and T variables in a sensitive area. Second, the incorporation of a GPS in the system adds the capability of registering a track campaign, passing from a static time series register to a moving time series record.

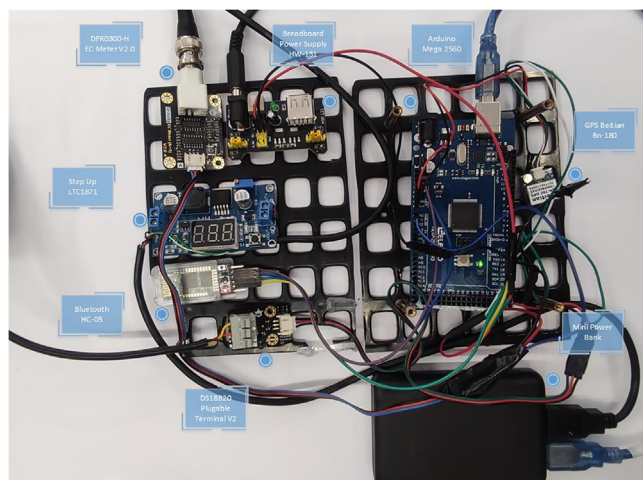

Fig. 1. Main components and connections of the EC + T track package.

The water research and water quality monitoring community would benefit in the following aspects:

- Water quality monitoring in surface water with a certain degree of salinity – e.g. estuarine, coastal lagoons, river mouths, open water, etc.
- Evaluation of the suitability of a site for the intake of water for purification treatment.
- Ease of installing different or additional sensors with the same controller, georeferencing tools and communication protocols, with a subtle adaptation of the database and Android App.

### Design files

The EC + T Track project design files are listed in Table 1 and provided in the referred repository. They provide the necessary information to replicate the electronics device and the 3D-printed water turbulence cap for sensors' protection. At the same time, the communications and Android based GUI software is also stored in the repository.

### Design files summary

#### Bill of materials

EC + T Track project bill of materials is presented in Table 2 and includes the main devices, components and sensors that integrate the project. Most of them can be purchased in Amazon or local electronic stores.

**Table 1**  
EC + T Track design files.

Design file name	File type	Open source license	Location of the file
Schematic (PCB layout)	jpg	CC-BY 4.0	<a href="https://doi.org/10.5281/zenodo.6798292">https://doi.org/10.5281/zenodo.6798292</a>
EC_T_track (Arduino Mega firmware)	Arduino	CC-BY 4.0	<a href="https://doi.org/10.5281/zenodo.6798292">https://doi.org/10.5281/zenodo.6798292</a>
Release_V2_VielcaAPK (Android software)	Android	CC-BY 4.0	<a href="https://doi.org/10.5281/zenodo.6798292">https://doi.org/10.5281/zenodo.6798292</a>
AplicationVielcaAPK (Android code)	Android	CC-BY 4.0	<a href="https://doi.org/10.5281/zenodo.6798292">https://doi.org/10.5281/zenodo.6798292</a>
Cilindro (3D printing design)	Blender	CC-BY 4.0	<a href="https://doi.org/10.5281/zenodo.6798292">https://doi.org/10.5281/zenodo.6798292</a>
Print3D (3D printing components)	stl	CC-BY 4.0	<a href="https://doi.org/10.5281/zenodo.6798292">https://doi.org/10.5281/zenodo.6798292</a>
DB_Mar Menor.csv (case study database)	csv	CC-BY 4.0	<a href="https://doi.org/10.5281/zenodo.6798292">https://doi.org/10.5281/zenodo.6798292</a>

**Table 2**  
EC + T track bill of materials.

Designator	Component	Number	Cost per unit	Total cost	Source of materials
Arduino Mega 2560	ELEGOO Mega 2560 R3 (Microcontroller ATmega2560) with USB Cable	1	24,99 €	24,99 €	<a href="https://tinyurl.com/25xp77an">https://tinyurl.com/25xp77an</a>
BT Module	HC-05 Wireless Bluetooth Module with Master-Slave base	1	11,99€	11,99€	<a href="https://tinyurl.com/y2h2axmh">https://tinyurl.com/y2h2axmh</a>
GPS Module	GPS Beitian BN-180 NEO-M8N GLONASS with antenna	1	28,98€	28,98€	<a href="https://tinyurl.com/ycrarrhk">https://tinyurl.com/ycrarrhk</a>
Breadboard Power Supply	Arduino HW-131 Dual Power Supply Module (3.3 V / 5 V)	1	5,49€	5,49€	<a href="https://tinyurl.com/yes83zu6">https://tinyurl.com/yes83zu6</a>
Mini Power Bank Charmast	Mini Power Bank 10400mAh Charmast	1	24,99€	24,99€	<a href="https://tinyurl.com/yc65uz5s">https://tinyurl.com/yc65uz5s</a>
Step Up	LTC1871 Voltage Boost Converter Module DC-DC (3–35 V)	1	8,99€	8,99€	<a href="https://tinyurl.com/bddw74rd">https://tinyurl.com/bddw74rd</a>
DFR0300-H EC METER V2.0	Analog Electrical Conductivity Meter Kit DFR0300 with EC METER V2.0	1	81,26€	81,26€	<a href="https://tinyurl.com/2nayp3ty">https://tinyurl.com/2nayp3ty</a>
DS18B20 PLUGABLE TERMINAL V2	Gravity: DS18B20 Temperature Sensor (Arduino Compatible)	1	5.90\$	5.90\$	<a href="https://tinyurl.com/uz7y6m22">https://tinyurl.com/uz7y6m22</a>

**Bill of materials summary**

*Build instructions*

An Arduino Mega (AM) [11] board was used as the central processing unit (CPU) of the system, that was enhanced with a HC-05 Bluetooth system [12] for communicating with a smartphone and a Beitian BN-180 GPS to provide the package coordinates in every measurement. This enriched CPU is directly powered from one of the USB connections of the power bank. A second USB connector of the power bank is used to power the step-up boost converter and get 12 V to feed both water quality sensors – i.e. EC and Temperature.

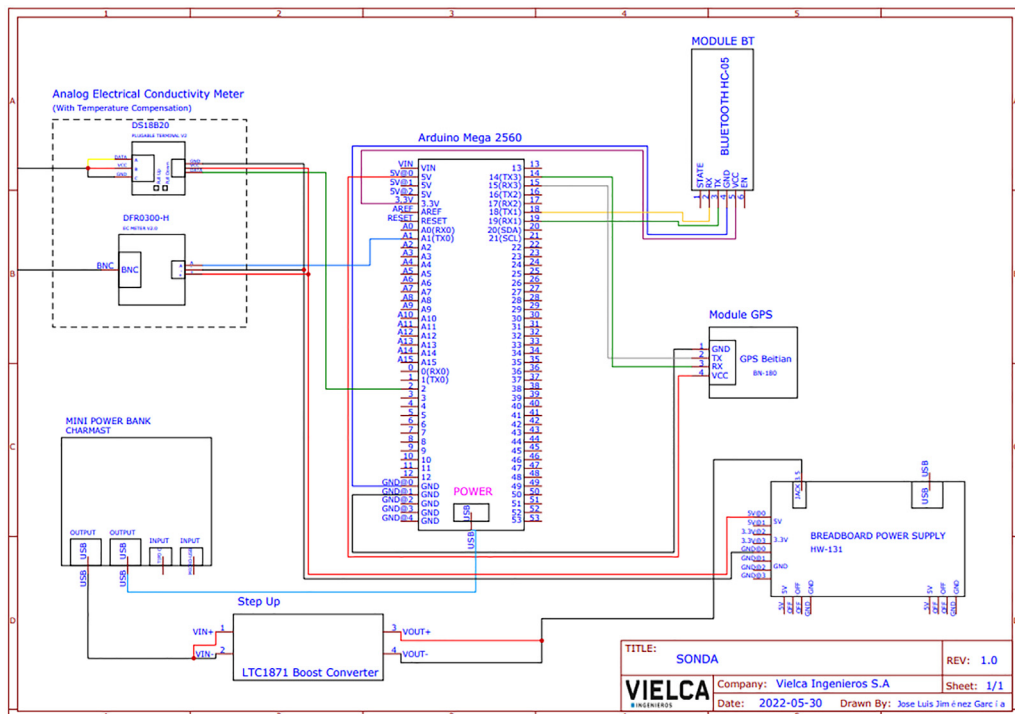

**Fig. 2.** Electronic schematics of EC + T track project.

(a) Power the device



(b) Check connectivity



(c) Seal the electronics



(d) EC calibration



(e) Protect the sensors



(f) Check App



Fig. 3. EC + T track operation instructions.

For building instructions, Fig. 2 presents the electronic schematics, including the pinning connections that must be considered. Additionally, an explanatory video was included in the corporative Youtube channel [13] to ease the reproduction of the project.

Finally, as for potential safety concerns, GPS and BT signals may interfere among them, for this reason it is important to place both components as separated as possible. Apart from that, all the electronics must be allocated in a floatable and waterproof recipient that would allow sensors to be in direct contact with water whilst working with electricity.

### Operation instructions

The electronic components must be safely fitted inside the waterproof recipient, and both AM and the boost step-up unit must be connected to the power bank. Once the electronic components are powered, Bluetooth (BT) connection and GPS systems are enabled and EC + T parameters and positioning can be checked in the Android APP – bear in mind that at this stage the sensors are not placed under the water yet and the EC + T measurements are not valid accordingly. Appropriate BT and GPS readings indicate that the device is ready to be sealed and Teflon stripe must be attached at the cap thread of the pipe before screwing it in.

Next, a calibration test for the sensors must be carried out – according to the EC manual [9] and test solutions, and both sensors – i.e. EC and T – must be protected with the 3D-printed cap before placing them in the water. The 3D-printed cap is built in two semi-prisms that are joined with flanges.

Before starting the measurement campaign, it is recommended the corroboration that the Android APP is receiving, storing and representing consistent values.

In summary, the following list presents the sequence of operation instructions (OI) in bullet points and Fig. 3 shows the main OI:

- Connect the two USB to the power bank – i.e. AM and boost step-up.
- Check smartphone connectivity for both BT and GPS.
- Seal the electronics inside the waterproof recipient.



Fig. 4. General location, main discharges and exchange channels of Mar Menor lagoon.

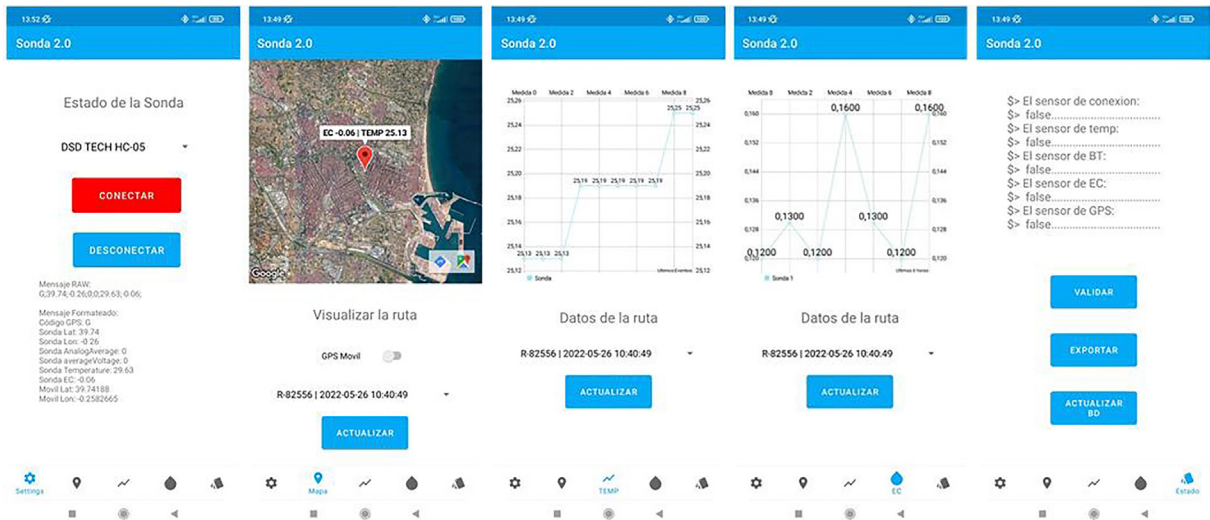

Fig. 5. Android App screens of the EC + T track project.



Fig. 6. Mar Menor lagoon demonstration route: (a) view of the package before fixing on board; (b) aspect during measurements.

- Calibrate EC sensor.
- Protect the sensors with the 3D-printed cap.
- Corroborate that the smartphone is registering the measurements.

## Validation and characterization

### Case study

EC + T track device was tested in a boat trip around Mar Menor lagoon as part of the EU H2020 project SMARTLAGOON. Mar Menor lagoon (Murcia, Spain), with its 135 km<sup>2</sup>, is the largest hypersaline coastal lagoon in Europe [14,15]. This water body is relatively shallow, with an average depth of 3.6 m and a maximum depth of 7 m, a 22 km long sandy coastal barrier (called La Manga) separates the lagoon from the Mediterranean Sea, although several channels allow the water exchange among them (see Fig. 4).



Fig. 7. Exportation data screen of the Android App.

Some of these channels – i.e. Estacio and Marchamalo – are manmade, allow navigation and their construction increased the flow exchange and downgraded the salinity of the lagoon, changing the ecosystem conditions and hydrodynamics in consequence.

EC + T track will bring a deeper knowledge of the salinity gradient – one of the major causes of the existing water movements inside the lagoon –, and thus of the sediment and rest of the constituents transport.

### Operation, Android app and database

Before going to the water, Android App must be initiated and Bluetooth connection with the EC + T track device must be started, receiving data in the log of the App and storing it in the database. Fig. 5 presents the different screens of the Android App that must be checked-up before starting.

As part of a boat trip around Mar Menor lagoon, the EC + T track device was setup and attached to the board for a water quality monitoring campaign. Fig. 6 shows: (a) boat and device after sealing the apparatus; (b) physical aspect of the package during measurements.

And data was received and stored in a database that can be downloaded in.csv format from the Android App. Fig. 7 presents the exportation data screen of the Android App.

### Data analysis

Database exported to.csv format can be easily edited in MS Excel also enabling the geographical representation of the results thanks to the registered coordinates of the package GPS.

Temperature was compared with the observed temperature provided by the navigation system of the boat, obtaining both values close to 24 °C. In case of Electrical Conductivity, the Autonomous Region of Murcia [16] provides daily average values for Salinity (psu) that can be used for calibration purposes. According to such database, the average salinity values on 27th May 2022 were 39.828 psu that are equivalent to 58.34 mS/cm of EC [17].

Fig. 8 represents the values obtained with the EC + T track device during the boat trip. Averaged values for EC – i.e. 56.04 mS/cm – are consistent with reported values [16].

### Battery duration and further analysis

A second validation test was carried out to check durability of the batteries and reliability of measurements. In this case, the EC + T track was placed together with the EC and T sensors of the EU H2020 SMARTLAGOON buoy in a bucket with water of the Mar Menor lagoon, during the assembly and testing tasks of the latter. Fig. 9 shows the experiment setup that was carried out from 22nd until 25th of September of 2022.

As the experiment was carried out inside a building with limited satellite coverage, EC + T track was adapted to do static measurements, considering that this could be an interesting performance of the system – either for long-term measurements



Fig. 8. EC + T track performance EC measurements during 27th May 2022 campaign.



Fig. 9. Battery duration experiment during EU H2020 SMARTLAGOON project assembly.

in a known position or for taking advantage of the coordinates measurements of the smartphone. In such a context, the GPS device was disconnected of the power supply.

With that configuration the battery lasted for more than 56 h, sending measurements every 3 s to the smartphone for data storing.

Fig. 10 shows the results of the experiment, both for (a) water temperature, and (b) EC during the time that EC + T track and EU H2020 SMARTLAGOON buoy remain together in the bucket.

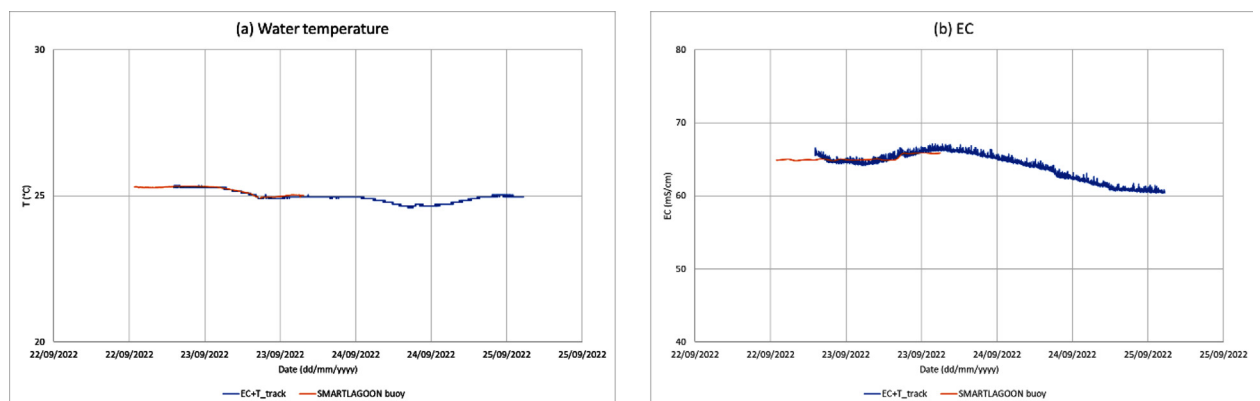

Fig. 10. EC + T track and EU H2020 SMARTLAGOON results comparison for (a) water temperature and (b) EC.

As can be observed in the figure, both water temperature and EC time-series measurements showed a good performance when comparing EC + T track and the calibrated sensors of the EU H2020 SMARTLAGOON buoy.

### Final remarks

Real-time measurements are scarce in the Mar Menor lagoon and that makes complicated a proper comparison of the EC + T track results. However, the adaptability of the solution allowed a calibration experiment that showed consistent values with the EU H2020 SMARTLAGOON buoy for more than 21 h.

The results demonstrate that the use of such technology for citizen science activities could lead to interesting information for the scientific community, with daily updates of information and different routes that could bring the opportunity to create daily raster maps of EC and T at Mar Menor lagoon scale.

### Conclusion

The EC + T track device described in this work constitutes a valuable alternative for water quality monitoring in surface waters with salinity or temperature derived problems, such as coastal lagoons, estuarine or open waters, and allows filling the knowledge gaps in different context, ranging from planning and project definition of water intakes in developing countries to the hydrodynamics modelling in a hypersaline coastal lagoon – that is the case of Mar Menor lagoon referred in the case study.

The project involves different disciplines and professionals – e.g. electronic and environmental engineering, programming, water management, GIS... – that have gained a collective experience during its implementation. In addition, the project can be adapted to monitor different water quality parameters, fulfilling the monitoring requirements of specific clients and problems.

Finally, the low-cost characteristics of the package and both: (a) the possibility of attachment of the device into different aquatic transport; and (b) the hardware adaptability of the solution; enables the replication and transfer of the project to citizen science activities, after engagement and training of key stakeholders and associations that could help with data collection during their navigation activities. For instance, fishermen in Mar Menor could measure EC and T and share them with the scientific community in their daily basis routines.

### Funding

This work has been supported by the European Union's Horizon 2020 research and innovation programme under grant agreement No 101017861.

### Declaration of Competing Interest

The authors declare that they have no known competing financial interests or personal relationships that could have appeared to influence the work reported in this paper.

### Acknowledgments

Authors acknowledge the Spanish Institute of Oceanography (IEO) for facilitating the boat trip around Mar Menor lagoon and both Ramón Blanco-Benet and Josep Arnau-Julià for their contributions during the initial field tests.

### References

- [1] M.C. Carvalho, Portable open-source autosampler for shallow waters, *HardwareX* 8 (2020) e00142.
- [2] G. Xu, Y. Shi, X. Sun, W. Shen, Internet of Things in Marine Environment Monitoring: A Review, *Sensors* 19 (2019) 1711, <https://doi.org/10.3390/s19071711>.
- [3] J.H. Ryu, UAS-based real-time water quality monitoring, sampling, and visualization platform (UASWQP), *HardwareX* 11 (2022) e00277.
- [4] W. Jo, Y. Hoashi, L.L. Paredes-Aguilar, M. Postigo-Malaga, J.M. Garcia-Bravo, B.-C. Min, UAS-based real-time water quality monitoring, sampling, and visualization platform (UASWQP), *HardwareX* 6 (2019) e00076.
- [5] C. Albaladejo, P. Sánchez, A. Iborra, F. Soto, J.A. López, R. Torres, A Low-Cost Sensor Buoy System for Monitoring Shallow Marine Environments, *Sensors* 10 (2010) 6948–6968, <https://doi.org/10.3390/s120709613>.
- [6] L. Zhao, K. Shirai, N. Murakami-Sugihara, T. Higuchi, T.T. Sakamoto, T. Miyajima, K. Tanaka, Retrospective monitoring of salinity in coastal waters with mussel shells, *Sci. Total Environ.* 671 (2019) 666–675, <https://doi.org/10.1016/j.scitotenv.2019.03.405>.
- [7] F. Adamo, F. Attivissimo, C.G.C. Carducci, A.M.L. Lanzolla, A Smart Sensor Network for Sea Water Quality Monitoring, *IEEE Sens. J.* 15 (5) (2015) 2514–2522, <https://doi.org/10.1109/JSEN.2014.2360816>.
- [8] M. Maar, E.F. Møller, J. Larsen, K.S. Madsen, Z. Wan, J. She, L. Jonasson, T. Neumann, Ecosystem modelling across a salinity gradient from the North Sea to the Baltic Sea, *Ecol. Model.* 222 (2011) 1696–1711, <https://doi.org/10.1016/j.ecolmodel.2011.03.006>.
- [9] DFR0300-H. Analog electrical conductivity sensor Dfrobot DFR0300-H specifications description. [https://wiki.dfrobot.com/Gravity\\_Analog\\_Electrical\\_Conductivity\\_Sensor\\_Meter\\_K=10\\_SKU\\_DFR0300-H](https://wiki.dfrobot.com/Gravity_Analog_Electrical_Conductivity_Sensor_Meter_K=10_SKU_DFR0300-H), 2022 (accessed 30.06.22).
- [10] SEN0198. High temperature Dfrobot SEN0198 specifications description. [https://wiki.dfrobot.com/HighTemperatureSensor\\_SKU\\_SEN0198](https://wiki.dfrobot.com/HighTemperatureSensor_SKU_SEN0198), 2022 (accessed 04.10.22).

- [11] Arduino Mega. Arduino Mega controller board description. <https://store.arduino.cc/products/arduino-mega-2560-rev3?queryID=undefined>, 2022 (accessed 04.10.22).
- [12] BT-05. Core Electronics User Guide. JY-MCU Bluetooth to UART Wireless Serial Port Module for Arduino. <https://core-electronics.com.au/attachments/guides/Product-User-Guide-JY-MCU-Bluetooth-UART-R1-0.pdf>, 2022 (accessed 04.10.22).
- [13] Youtube. EC+T track: Water quality monitoring. <https://youtube.com/playlist?list=PLEnahMsbJPbxQyknsh8n2XBetc786anMI>, 2022 (accessed 04.10.22).
- [14] J. Senent-Aparicio, A. López-Ballesteros, A. Nielsen, D. Trolle, A holistic approach for determining the hydrology of the Mar Menor coastal lagoon by combining hydrological & hydrodynamic models, J Hydrol 603 (2021), <https://doi.org/10.1016/j.jhydrol.2021.127150> 127150.
- [15] J.M. Cecilia, P. Manzoni, D. Trolle, A. Nielsen, P. Blanco, C. Prandi, S. Peña-Haro, L. Barkved, D. Pierson, J. Senent, SMARTLAGOON: Innovative modelling approaches for predicting socio-environmental evolution in highly anthropized coastal lagoons, (GoodIT'21), September 9–11, 2021, Roma, Italy. ACM, New York, NY, USA, 6 pages. doi:10.1145/3462203.3475925.
- [16] CARM. Scientific data server of Mar Menor lagoon. <https://marmenor.upct.es/>, 2022 (accessed 04.10.22).
- [17] EC-Salinity calculator. <https://www.oceanlife.it/index.php/en/19-notizie/370-water-salinity-converter-en>, 2022 (accessed 04.10.22).



**Dr. Pablo Blanco-Gómez:** Head of R&D Department at Vielca Ingenieros, S.A. ORCID: <https://orcid.org/0000-0001-9465-2912>. Research Areas: Hydrology, Hydraulics, Water Quality Monitoring, GIS, Marine IoT.

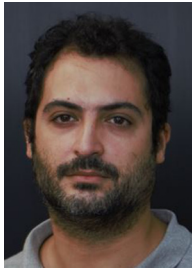

**Mr. José Luis Jiménez-García:** IT engineer at Vielca Medio Ambiente, S.L. ORCID: <https://orcid.org/0000-0001-6619-9057>. Research Areas: Software development, Electronics, Hardware prototyping.



**Dr. José M. Cecilia:** Ramón y Cajal Fellow (Tenure-track associate professor) - DISCA, Universitat Politècnica de València (UPV). ORCID: <https://orcid.org/0000-0001-5648-214X>. Research Areas: Big Data analytics, High Performance Computing, Machine Learning, Parallel Computing.