

# SILESIAN UNIVERSITY OF TECHNOLOGY

## FACULTY OF CIVIL ENGINEERING



ENGINEERING FINAL PROJECT

### *Framework Study and Analysis in Spain-Poland*

Author:

**Soraya Serna Muñoz**

Universidad Politécnica de Valencia

2010/2011

Supervisors:

**Rafał KRZYWON PhD CEng**

# INDEX

---

<b>1. INTRODUCTION</b>	<b>3</b>
1.1 OBJECTIVE AND SCOPE OF THE PROJECT	3
1.2 HISTORICAL BACKGROUND	4
1.2.1 GLIWICE	4
1.2.2 TYPICAL BUILDINGS	9
<b>2. ANALYSIS OF FRAMEWORK</b>	<b>13</b>
2.1 DEFINITION OF FRAMEWORK	13
2.2 HISTORY AND DEVELOPMENT OF FRAMEWORK	13
2.3 FUNCTIONS	17
2.4 DETERMINING FACTORS TO CONSIDER FOR CHOOSING A FLOOR	21
2.5 MATERIALS	21
<b>3. FRAMEWORKS EMPLOYEES IN POLAND</b>	<b>25</b>
3.1 WOODEN FLOORS	25
3.2 MONOLITHIC FRAMEWORKS	30
3.2.1 ACKERMAN, CERAM, CERIT, FERT...	30
3.2.2 JS	35
3.3 PRECAST	37
3.3.1 FILIGRAN	37
3.3.2 BEAM-PLATE	39
3.3.3 PSKJ-S	40
<b>4. FRAMEWORKS EMPLOYEES IN SPAIN</b>	<b>42</b>
4.1 UNIDIRECTIONAL AND BIDIRECTIONAL FRAMEWORK	42
4.2 PREFABRICATED SLABS	44
4.2.1 ALVEOLAR SLAB	44
4.2.1.1 Features	
4.2.1.2 Applications	
4.2.1.3 Work placement	
4.2.1.4 Costruction details	
4.2.1.5 Advantages	



4.2.2 PRE-SLAB	52
4.2.2.1 Features	
4.2.2.2 Applications	
4.2.2.3 Work placement	
4.2.2.5 Advantages	
4.2.3 FLOORS WITH SEMI-RESISTANT ELEMENTS	56
4.2.4 FORGED METAL (DECKING)	57
4.2.4.1 Features	
4.2.4.2 Applications	
4.2.4.3 Work placement	
4.2.4.4 Advantages	
4.3 FORGED IN SITU	61
4.3.1 SOLID SLAB	61
4.3.1.1 Features	
4.3.1.2 Applications	
4.3.1.3 Advantages	
4.3.2 WAFFLE SLAB	63
4.3.2.1 Features	
4.3.2.2 Applications	
4.3.2.5 Advantages	
<b>5. COMPARATIVE STUDY</b>	<b>67</b>
5.1 DIFFERENCES AND SIMILARITIES BETWEEN DIFFERENT FLOORS IN BOTH COUNTRIES	67
<b>6. ACKNOWLEDGEMENTS</b>	<b>70</b>
<b>7. REFERENCES</b>	<b>71</b>

# Chapter 1

## INTRODUCTION

### 1.1 OBJECTIVES AND SCOPE OF THE PROJECT

---

This Project focuses on the study and analysis of one of the constructive parts of buildings, the framework.

Due to the special situation of being making my project in the city of Gliwice in Poland, I wanted to introduce part of the culture of this country, studying the different construction methods used in the performance of the slabs.

During the project, our goal is to identify the different types of floors used in Poland, the materials used, as well as the most common problems that occur in those and the solutions that are often used.

In the first chapter I will refer to the city of Gliwice, showing some of the features that have influenced in the design and construction method of the framework. In addition, I will include pictures with the most distinctive buildings.

Then, I begin with a brief introduction to the concept of what we nowadays understand by "framework", its most important features and functions. This will give a first idea about its possible practical applications in work. We will also briefly review its evolution in the history of the building, showing as they have been changing and improving the types and how, with time, have a greater tendency to others.

Finally, we will look at some of the different types of floors used in Poland and Spain, making an analysis of the differences and similarities found between both countries.

## 1.2 HISTORICAL BACKGROD

---

### 1.2.1 GLIWICE

Gliwice is one of many towns in the largest industrial area in Poland, paradoxically being very different from the stereotype of an Upper Silesian town. It is a city of culture, of science and of enterprise, with aspirations to become a separate administrative centre in Silesia. As one of the oldest towns of the Upper Silesian region, it boasts a good Old Town and several interesting sights.

Like other towns of the Upper Silesian conurbation, Gliwice is known mainly as an industrial centre. The best-developed industries are coal mining, steel making and the production of machinery and chemicals. The inland port on the Gliwice Canal gives it access to the Baltic Sea via the Odra River. Gliwice is also an important educational centre, home to most of the departments of the Silesian Polytechnic. The population is around 200,000 people.

Until the administrative reform in Poland in 1999 belonged to Gliwice-Katowice Voivodship, since then, is one of the 17 districts of Silesia Voivodship.



Picture 1.2.1: Gliwice. Silesia Voivodship. Polonia  
Source: ([www.wikipedia.es](http://www.wikipedia.es))

### Late Middle Ages

Gliwice used to be a borderland city, as it was governed by different countries, which is clearly indicated by its rich history. The city was afflicted by wars whereas plagues and fires were commonplace here. However, due to its favourable location at the junction of strategic trade routes, the city continued to keep abreast of the times, which was revealed in its readiness to accept challenges and adopt novelties.



*Picture 1.2.2: Old town infrastructure in Gliwice in XIV-XIX centuries  
Source: Own picture. Gliwice's Museum .*

The first of the routes connected Cracow and Wrocław, while the second one (widely known in Europe as the "amber route") led from the south of Europe to the Baltic Sea. The city was first referred to as early as in 1276. The city was at that time included within the Polish boundary lines, and its location was related to the

proximity of Bytom. According to the historians, in the XIV

century Gliwice was a defensive city, and it was governed by Siemowit, titled the Duke of Gliwice.

During the reign of Mieszko Plątonogi, the grandson of Bolesław Krzywousty, Gliwice constituted the Duchy of Opole and Racibórz. However, as early as in 1289, after the Duchy had been divided up among the four sons, the area of Gliwice became a separate duchy, which was soon ruled by Waclaw II, the King of Czech. At that time the land was famous for fish-culture, flour-milling, hop-growing and consequently the production and sale of beer. At the times of the Teutonic Knights' hegemony when Kazimierz Wielki relinquished his rights to the territory of Poland, Gliwice was ruled by Duke Władysław and Siemowit respectively. The period of relative peace was interrupted by the Hussite invasion.

### Early Modern Age

The city was then inhabited by about 1200 people who earned their living mainly from brewing. In 1532 after the death of the last ruler deriving from the Piast line of descent, the city was governed by the Habsburgs. It was the beginning of the debilitating 30-year war, which was then vividly remembered

for a long time. It was also the period of protracted religious conflicts, the teachings of Martin Luter, and great hopes of returning to the Polish boundary lines. During that time Gliwice changed noticeably. Fortifications were replaced by settlements and gardens which resulted in the greening of the city. The war between the Habsburgs and the Turks and the following lack of resources was the reason for leasing Gliwice (as so-called Gliwice State) to Fryderyk Zettritz, for the sum of 14 000 thalers.

The contract was originally concluded for 18 years, but it was prolonged twice: for another 10 years in 1580 and for another 18 years in 1589. In 1596 the city of Gliwice was sold to the city authorities for the sum of 27 thousand thalers thus becoming a free royal city. The villages of Knurów, Krywald, Ostropa, Trynek and Szobiszowice were also included.

In 1683 the city was honoured by the presence of Jan III Sobieski, who was on his way to relieve the besieged city of Vienna and had a brief sojourn in the Franciscan Order priory adjacent to the Holy Cross Church (at present it is the Redemptorist Order priory).

The main source of the residents' economic well-being was the brewing industry. However, as a result of successive fires in 1711, 1730 and 1735 the brewery was burnt down thus bringing this profitable business to ruin.

The years 1740-1763 marked the period of so-called Silesian wars waged between Austria and Prussia. Under the Prussian rule Gliwice witnessed the onset of capitalism. At that time there was the development of suburbia, where the housing estates for steelworkers were being located. The network of mining and steelworks offices was developed, with the Mining Institute (Wyższy Urząd Górniczy) at the forefront. Due to the authorities efforts the trade routes were developed and the means of transport modified. At the time, the Kłodnica Canal (Kanał Kłodnicki) was also being built. Its purpose was to enable coal floating as well as protect the city against the exasperating seasonal floods. The construction of the canal took 30 years (1792 -1822). The coal from Gliwice was cheaper than the English one so it was frequently imported to the Berlin market.

### **Industrialization**

In 1796 the state ironworks was opened. It won renown in Europe for the art casting as well as the military production as it was here that the first cannon was cast in 1804. During that time the first coke-fuelled metallurgical furnace, designed by John Baildon, came into operation.

In 1810 the Franciscan Order was dissolved. The priory buildings were appropriated by the state and the first grammar-school was opened there. In 1834 the post office was opened.

The element that largely contributed to the city development was the opening of the railway line connecting Wrocław to Gliwice in 1845, which was subsequently extended to Mysłowice.

In 1887 the administrative district was established in Gliwice. The city was self-governed and its economic and cultural progress was dependent exclusively upon its citizens. As a result of the economic growth, small factories were being developed and modernized with the new ones being opened at the same time. In 1883 the heirs of the founder of "Hermina" steelworks, Oskar and Georg Caro became the owners of "Julia" steelworks in Bobrek. In "Obereisen" company, which they had established together with Wilhelm Hegenscheidt, they exerted their control over the increasing number of factories, thus becoming an important power. The town's ironworks fostered the growth of other industrial fields in the area. During the late 19th century Gleiwitz had: 14 distilleries, 2 breweries, 5 mills, 7 brick factories, 3 sawmills, a shingle factory, 8 chalk factories and 2 glassworks.

In 1892 the first horse-drawn tram line was opened, which was then extended as far as to Piekary Śląskie. Three years later, first electric trams appeared in Europe. In 1899 the theatre was opened, where actors from all parts of Europe, especially Germany, performed until the World War II.

### **20th century**

During World War I the economy and industry centred on the military production. Some factories were closed and the employment was reduced. The years 1919 - 1921 were marked by three Silesian uprisings and the plebiscite, whereby the residents were to decide if they wished to be considered



Picture 1.2.3: Gliwice after the Second World  
Source: Architecture University Politechnika Slaska



Polish or German citizens.

The residents of Gliwice were in favour of the German nationality, whereas 88 out of 102 communes of Toszek and Gliwice administrative district were in favour of the Polish nationality. In 1922 the disputed territory was divided between the two countries. In 1928 the modern Hotel was built ("Oberschlesien Haus"). At present it is the seat of the Municipal Office (present Zwycięstwa Street).

On 31 August 1939 there was a simulated attack upon the radio station (present Tarnogórska Street). The event was supposed to give the German army a pretext for invading Poland. During the war years the city was entirely concentrated on military production. In Gliwice there were four labour camps, branches of the Oświęcim concentration camp, which were the source of cheap labour force. In 1945 the city was occupied by the Red Army. Peace conventions settled the dispute of the national status of Gliwice. The decision was to incorporate to Poland some of the German territories, including Gliwice. Therefore the city of Gliwice was back within the Polish boundary lines.

After World War II Gliwice became an important centre of science and economy. The Silesian Technical University was established here. Professors of the Lvov Polytechnic and Lvov University comprised the majority of the staff. Institutions and design offices are created. The chemical industry was dominant. Gliwice became the chemical capital with the Chemical Industry Central Management at the forefront. Afterwards, the Anti-Cancer Institute, the Silesian Operetta and the museum were opened. In 1992 Gliwice became a seat of the newly-created Diocese of the Roman Catholic Church. In 1998 there was an opening ceremony of the Opel Poland plant - the biggest foreign investment in Poland.

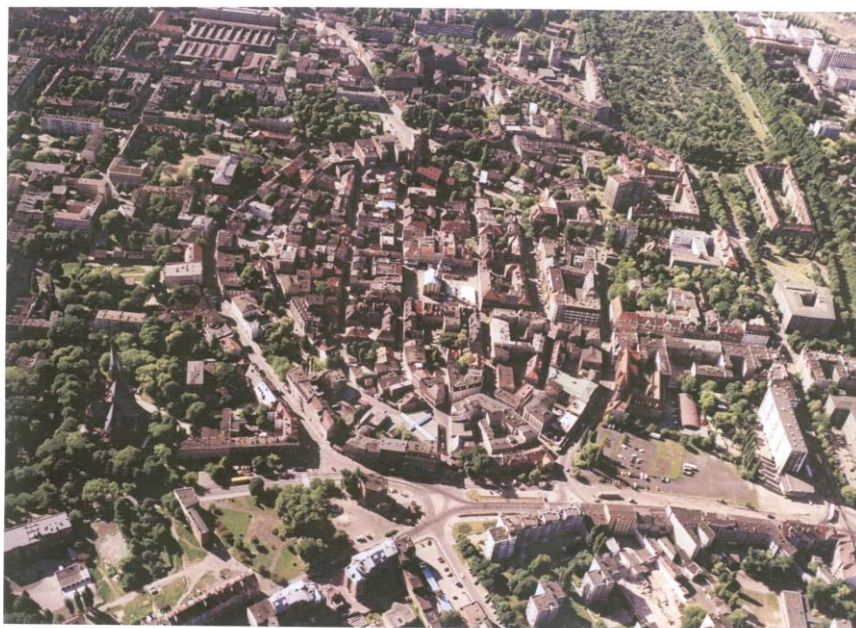

*Picture 1.2.4: Gliwice after the reconstruction*  
*Source: Architecture University Politechnika Slaska*

### 1.2.2 TIPYCAL BUILDINGS

Founded in the 13th century, the Old Town of Gliwice still manages to retain its mediaeval layout and even the city walls dating from the turn of the 15th and 16th centuries have been partially spared. Gliwice has three, easy to notice architectural styles. First one is old and monumental – it is examples are Piast's Castle and City Hall, both from XIV/XV century and several old churches, the villa of Caro, some pretty tenement houses and the 19th century Town Hall.



Picture 1.2.5: Piast's Castle.  
Source: ([www. Wikipedia.es](http://www.Wikipedia.es))



Picture 1.2.6: Main Square and City Hall  
Source: Own picture



Second one is simply stunning – great masonry buildings from the beginning of 20th century, like two faculties of university, which are commonly called Grey and Red Chemistry. Gliwice is also one of the birth-places of modernism – Weichmann’s Textile House built here was commonly copied in Germany.



Picture 1.2.7: The textile warehouse of merchant Weichmann, located at Zwyciestwa Street (Wilhelm Strasse), designed by Erich Mendelsohn (currently a branch of PKO BP Bank).

Source:



Picture 1.2.8: Chemistry Faculty and Post office of Gliwice

Source: Own picture

Unfortunately there's also the third face – the boring one, mostly coming from communist times. Buildings designed to have high quantity, instead of quality are never valuable. Fortunately this kind of architecture is gradually eliminated.



Picture 1.2.9: Buildings with ten floors

Source: Own picture

During the Second World, Gliwice was inhabited for many german people. This influence affected in the type of buildings too. The news constructions were classified in three types of edification. In the picture 1.2.10 we can see these.

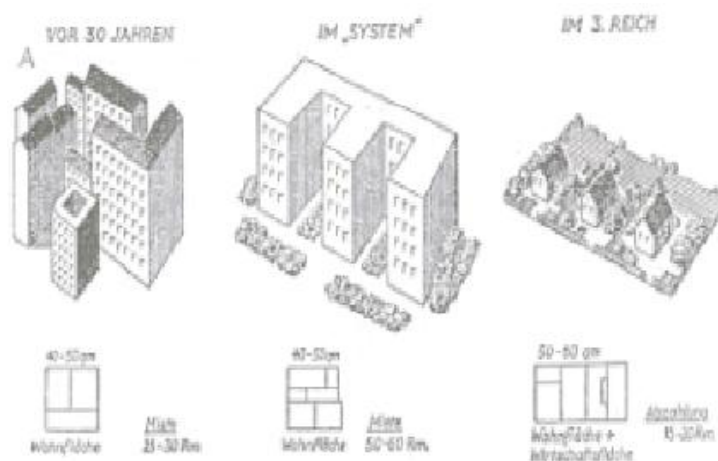

Rys. 166. Charakterystyka niemieckiej zabudowy mieszkaniowej; początku XX w. / Republiki Weimarskiej / III Rzeszy, 1935 r.

Picture 1.2.10: Different types of buildings.

Source: Book

There are more than 150 tenement houses in Gliwice, which are a compilation of the three styles: historic, eclectic and secession. There were built in the traditional construction from the XIX-XX century, but with a new decorative details.

There are lots of common characteristics for all the housing buildings for burghers/townsmen in all Upper Silesia and even in the whole country.

Some typical characteristics of the secession houses:

- A part of continuous buildings along the street.
- Usually 3 or 4 floors, shops on the ground floor.
- Representative elevation, service rooms (bathroom, kitchen) from the back side.
- Always staircase in the middle, two flats on two sides on each floor, the bathroom (toilet) often outside the flat, in the staircase.
- Construction: wall from bricks, ceilings - non-inflammables, with metal moulders fulfilled with ceramic material, supported by metal columns
- Decorative details (verticals, asymmetry, little towers on the corners, union of different elevation materials - stone, brick, wood, stucco, glaze; syncretism in style, decorative parts in the upper part of elevation, stylish windows and door, organic and geometrical ornaments)
- In interiors: ceramic, stucco, stone flooring, stained glass



Picture 1.2.11: Secession Tenement Houses.

Source: Own picture

# Chapter 2

## ANALYSIS OF FRAMEWORK

### 2.1 DEFINITION OF FRAMEWORK

Framework refers to the slab surface structural element, usually horizontal, that consist of the floor resistant base and some covered gables. Is responsible for receiving loads directly that supports, as its own weight, and transmit them to the other elements of the structure (beams, columns, walls), making possible the functionality of the building.

### 2.2 HISTORY AND DEVELOPMENT OF FRAMEWORK

The use of the floor began to be necessary with the first urban settlements, to save and fill in the gaps that the man needed to live. And especially when these areas began walling and wars between peoples transcended the small fights for survival and became instruments of expansion, domination and power.

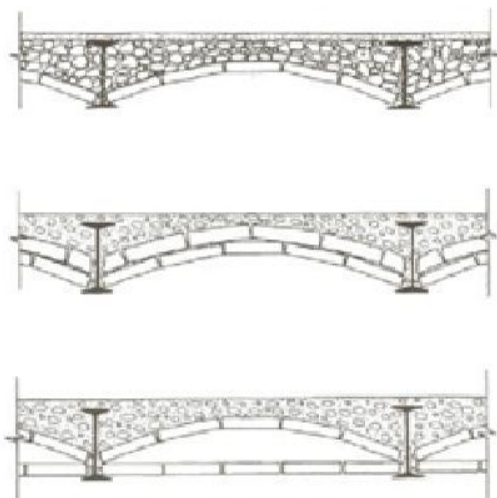

As the walled space, limited and scarce, he began to acquire courage to build up other areas for better use. In fact, in the city of Ur (Iraq) around 2000 BC, there were already some two-storey houses, as at Thebes (Egypt) 1500 BC.

The more robust method used was to simply supported beams and vaults on load-bearing walls, which will be later replaced by reinforced and prestressed concrete flat slabs shaped.

In the Mycenaean and Greek houses were mostly of a plant. In general the architecture of big cities was quite poor with the exception of existing temples and public buildings.



Back in the days of Roman splendor, to alleviate the concentration of population in the city, poor-quality apartments built based on brick walls, wooden floors and stairs (island) who reached the six plants. After the great fire of Rome in 64 A.D. they tried to improve the urban situation of the city but only succeeded in Ostia.

Since Roman times to the twentieth century vernacular architecture was characterized by basically using load-bearing walls and slabs of wood, except for some unique construction met with vaulted stone slabs or bricks. The fact of using forged before the vaulted wood was because the vertical walls cheapened by not producing horizontal thrust. To compete with the quality of insulation offered by the vaulted ceiling, the densified wood forged the elements that could bear resistant to successive layers of rubble and mortar until the final pavement. The problem was that there were very few reserves to withstand the surge (3 or 4 KN/m<sup>2</sup>).

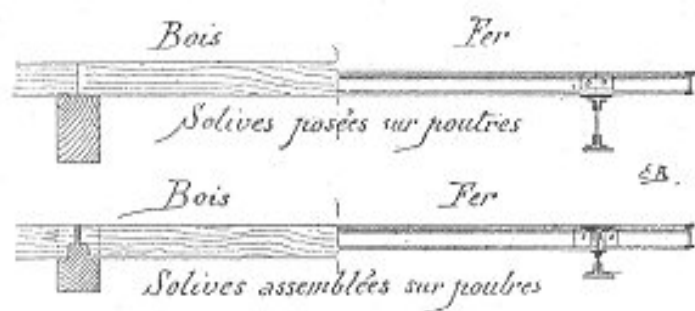

Fig. 748 à 751.

In the late eighteenth century, the advent of the Industrial Revolution led to the use of iron in an industrial building. The industries built demanding which have been different open spaces removed from the rigid and opaque brick bearing walls and Pillars. With iron was achieved by

gradual release of the load-bearing walls as vertical bearing elements of buildings.

Cast iron initially used in combination with stone, brick and wood floors alike. Later, the beams and cast iron beams and slabs were used in the construction of factories. The cast iron columns played an important role in all kinds of construction and little by little, the steel structures made their way from the hand of bridge engineers and R. Stephenson, Brunell, Telford, Eiffel ...

Already in the nineteenth century, in parallel with the development of steel structures, reinforced concrete was born.

From the second half of the nineteenth century industrial cement was already available thanks to advances in Vicat, with its study and development of hydraulic lime (1818), Aspin with his work on artificial stone (1824), with its cement Johnson of "grappiers" and Ransome with horizontal rotary kiln.

But between 1880 and 1890, once you have glimpsed its robust operation and its advantages as a construction material (mainly fire resistance and the economy), they appear many patents for commercial exploitation.

In the U.S., development of reinforced concrete catapulted after the construction of the Pacific Coast Borax stores. Floors were constructed of solid slabs supported on bearing walls, steel beams and then concrete beams, which were not based on any structural analysis, simply load tests. No one knew how to calculate the slabs or that standards applied to assemble them.

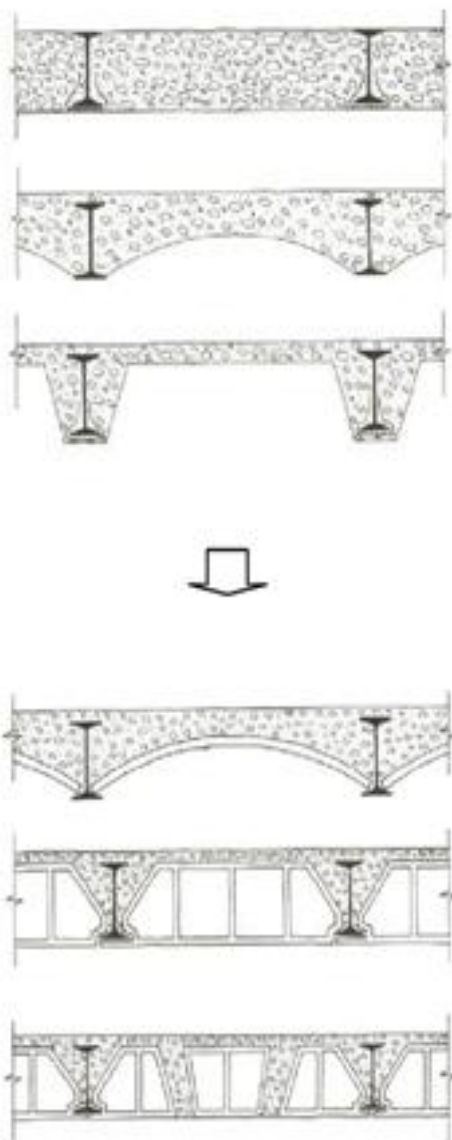

In Spain, after the Civil War and entered the 40's, was on concrete, steel and wood and technological expertise to develop constructively and forgings.

The wooden floors were falling into disuse, especially in large cities. The calculation of these slabs was carried out based on tables that are entered with the value obtained by multiplying the service load and light load the band in the column on the right light.

Metal decks supported on bearing walls and metal gates had a great development on the 60. He later established the widespread use of concrete floors, all and in the field of bridges and unique architectural buildings are still preferred. In tall buildings, however, high-strength concrete (100 MPa) are preferable to metal structures.

Metal decks are the ideal solution in individual cases where it is not possible to use concrete, especially everything related to the world of repair, restoration, rehabilitation as well as industrial buildings.

Finally ended up imposing concrete. To be in place by Freyssinet in the 30's, prestressed concrete, it became possible to build large-scale prestressed beams contributing to the development of one-way slab system. Prestressing was also developed in his variant of post-tensioning, with an important application in buildings where lights are needed and important service charges, which were around  $4\text{KN} / \text{m}^2$ . They remain more affordable post-tensioned slabs traditional but more complicated situations to settle. Semiviguetas system and relieving arches evolved in all its forms and created many variations.



Little by little they were discarding less profitable solutions based on quality and efficiency.

The other major type of floor that evolved later, is the grid. Belongs to the family of reinforced concrete slabs, not homogeneous, lightened and armed in two orthogonal directions. Initially performed a continuous slab abuts elastically in a grid of beams, together with the media, a set of frames were cross orthogonally. Later the structure was lightened by removing unnecessary mass. Today is one of the solutions used due to cost savings compared to the waffle floor slab in the usual construction.

Looking to the future expect the ultimate evolution of flat slabs due to the economic and functional benefits they provide. Charged beams and prestressed concrete and structural steel will maintain its field of application in special buildings, industrial buildings and commercial buildings, where lights and make loads impractical flat slabs.

The prestressed hollow core slab is prime basic solutions where speed and strength capacity. The slabs of concrete decking is not expected to have a more than occasional because of the cost and sensitivity to fire, although some types are currently seeking to compete with concrete floors.

Finally, we must turn to talk about the importance of reticulated with coffered lightening. The comfort, safety, fire resistance and economic cost competent to ensure that traditional one-way slabs penetrating the market further. The coffered recoverable are important in places where, in addition to large spans and loads, is important to get a decent aesthetics. Furthermore, the concept of the caisson, to work on improving other qualities besides those resistant thermal insulation, high resistance to fire ...

As for the self-supporting one-way slabs prestressed beams continue to be used in situations where there is little lifts and sanitary floors. In the same field may also enter the alveolar plates, allowing longer spans than the latter. The floors will be losing semi-tie-beam unidirectional share market, especially in cities and buildings of a certain entity.

## 2.3 FUNTIONS

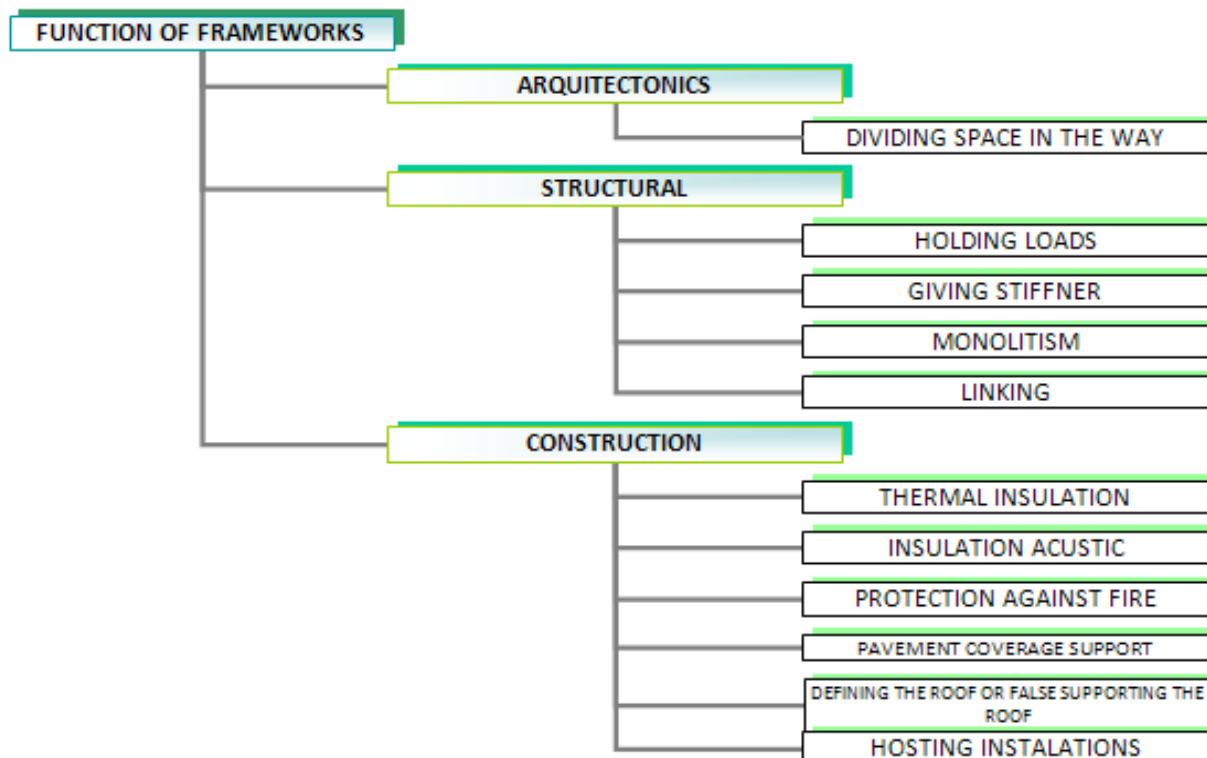

### ARCHITECTONIC FUNCTION

Dividing the vertical space in subspaces generating various levels of use.



Picture 2.3.1: Building with differents floors

## STRUCTURAL FUNCTION

1. Resisting the loads of used, with the corresponding safety factors.
2. Do not have deformation or excessive vibration.
3. Transmit vertical loads through the pillars, to the foundation and the ground
4. Acting as screens to the horizontal deformations.
5. Contribute to reducing the buckling length of the pillars providing horizontal rigidity.
6. Contributing to reduction of torsion beams.

To fulfil these structural features, they must achieve the following conditions:

### Bending stiffness

It is determined by the ratio  $f/l$ , where “ $f$ ” is the arrow produced by the designed load “ $q$ ” and “ $L$ ” is the span of the framework, the distance between columns. Consequently, when we have to much more rigidity, this coefficient will be lower.

### Monolitism

Although the framework is made up by many individual elements; its purpose is to act as a single piece. This usually is accomplished with the construction of a slab of compression.

### Linking

The framework, beams and pillars, transmit vertical loads to the foundation It must be ensured the transmission of horizontal forces in the plane the framework, to accomplish with this, straps or beams placed at the perimeter edge.

### Compliance service actions

During the lifetime of the building, the structure should be maintained at an acceptable level of service conditions (vertical and lateral deformations, cracking of the pieces, armour elongation...)

## CONSTRUCTIVE ROLE

### Thermal Insulation

Objectives:

- Achieve energy savings
- Ensure the thermal comfort of the users
- Improve the durability of building

These objectives are achieved by taking into account:

1. Global transfer coefficient of the building  $K_G$ , Resulting from the weighted average of the transmission Coefficients of all elements of separation from the outside.
2. Transmission coefficient of each one of the different separation elements from the outside. The thermal resistance  $R$  is the inverse of  $K$ .

$$K = \frac{1}{R_T} = \frac{1}{\frac{1}{h_i} + \frac{1}{h_e} + \sum \frac{L_i}{\lambda_i}}$$

3. Appropriate constructive composition.

### Acoustic Insulation

Objectives:

- Protect users from excessive noise

1. Air sound insulation  $R \geq 45\text{dB}$

$$R = (L_{I_1} - L_{I_2}) + 10 \cdot \log \frac{S}{A}$$

2. Impact noise level  $\leq 80\text{dB In}$

### Fire protection

Objectives:

- Controlling fire in areas of fire, configured by building blocks to allow the evacuation.

It is set the fire behaviour at:

1. Materials
2. Building components

Types of behaviour of materials against fire:

The fire behaviour of all the elements, it is characterized by the time during which the element remains:

- The stability or bearing capacity.
- The absence of gas emission in the unexposed face.
- Tightness passage of flame or hot gases.
- The thermal resistance sufficient to prevent the occurrence on the unexposed side, temperatures higher than those set forth in the UNE 23,093.

Standard requirements:

1. When an item is required to have fire stability, it must fulfil the a) condition. This is due to the structure and function using the enclosure of the same and the maximum height of escape from it.
2. When an item is required to be fireproof, must comply with conditions a), b) and c).
3. When an item is required to be fire resistant, it shall comply with all conditions above. In addition, if the element separates sectors of fire, its fire resistance shall be at least equal to the required fire stability.

The requirements to be fulfilled by reinforced concrete slabs are covered in the CTE, art.11 Part I: Basic Requirements for Fire Safety (SI 6: Structural resistance to fire).

## 2.4 DETERMINING FACTORS TO CONSIDER FOR CHOOSING A FLOOR

---

For the choice of cast must be taken into account the existence of certain pre-conditions:

- Cost of alternative systems in order to choose the most economical equality of the above conditions.
- Magnitude of the lights and charges.
- Elements precast in the zone.
- Type of finishes that are required (for example, in the finished lower flat roofs are required).
- Possible quality of concrete in terms of local materials and manufacturing means.
- Distance to that is the source of supply if it is prefabricated.
- Availability of skilled labour.
- Aids with which may be counted for the elevation, compaction, metal, scrap, shoring, form work, etc.
- Frequency fore see able technical supervision of the work.
- Level of quality control provided both the materials and execution.

## 2.5 MATERIALS

---

Floors may have different design and may be made of various materials which are affected by considerations such as:

- Kind of loads it will have to bear
- Span (distance between supports)
- Exposure degree to aggressive environments
- Required fire resistance

- Availability of materials
- Expected life
- Runtime
- Cost
- Etc.

As rational savings required in the design and construction, and reduce the use of steel and wood structures and formwork. In today's construction industry are becoming more widely used slabs of prefabricated elements which, inter alia, make it possible to achieve ever greater dimensions, thus allowing for the covering of one element of the entire premises.

The main materials used in the preparation of forged are:

- Wood
- Reinforced concrete
- Steel-reinforced concrete (mixed)

### Wooden floors

Although the wooden floors have many advantages, over 40 years of socialist construction in Poland, have been forgotten and neglected. During this period they dominated over reinforced concrete slabs. But in the last decade have begun to return to favour. Increased availability of wooden construction, with many mills, there are new measures to impregnate wood. In view of the Renaissance wooden ceilings try to compare the advantages and disadvantages of concrete and wooden floors with the following table.

REINFORCED CONCRETE FLOOR	WOODEN FLOOR
Heavier	Lighter
Possibility to transfer larger loads	Reduced strength of reinforced concrete
Exercise should professional team	Greater Opportunities in Terms of Economic self-execution method

More expensive in execution	Cheaper Performed
High fire resistance	The Need for Additional steps (Impregnation, padding gypsum boards) to get any fire resistance
The demolition or Alterations, large Expenditures of work and 100% loss of built fabric	Ease of change in any alteration function
The Necessity of Additional layers (sound insulation, thermal) prior to the target floor	Possibility of roof pieces (the structures of the floor beams make fun target and We Can Benefit from the ceiling), The Other layers (insulation & ceiling), we can do this Later
Ceiling after finishing required to Achieve Satisfactory appearance	Ceiling decorative appearance ITS Immediately after execution
The trouble Installing the (need for forging grooves)	Ease of doing all the Installations on the ceiling
Very high durability of the floor	Sometimes persistence limited by the ceiling of wood biological corrosion
High resistance to moisture floor	Low resistance of the floor in wet areas
Cement floors Are present in the Un certain degree of radioactive and has a negative Impact on human	The use of natural material (no adverse effects on human)
Improved sound absorption due to the large mass	Poor acoustic properties
With the Need to carry out the work performance of wet	Work related to the execution of the floor is clean, no clutter on the site bring
They work as a shield, an additional stiffening of the building construction system	Not be Used in Cooperation with the design of the building (in Addition to homes in the skeletal system, Canadian)
The Need for the use of tools (drill) to the Mounting of all elements	Easy to mount decorative and utility items

### **Reinforced concrete slabs**

The reinforced concrete slabs are generally compose of beams and precast concrete beams (reinforced and prestressed or not), slabs (or lightening parts of mortar or ceramic), and compressed concrete layer, lightly armed.

There are also solid concrete slab, which is called slab. The slabs are the type of floor heavier loads and more support. If the slab thickness decreases it can get to work as a blade.



The concrete floors are the most wide spread Spain by the wide and inexpensive availability of material. As we noted in the table, is the type of floor heaviest of all, but also more rigid. It can withstand heavy loads, even with wide angle, it is monolithic, high fire resistance and acoustic insulation acceptable.

There are also prefabricated concrete slabs whose execution time is less than conventional. Conform with precast slabs or hollow core slabs.

### **Forged steel and concrete mixed**

The composite slabs of steel and concrete are usually shaped by beams or steel beams, corrugated steel sheet metal as well, and finally compression layer of concrete, reinforced with an extra. Usually called composite slabs.

Used when the main structure is steel and wrought must resist medium loads. Requires the same protections as a cover folded sheet metal, but the increase of resistance that gives the concrete allows its use as thin slabs in building plans. If used in the formation of a cover concrete can be ignored.

## Chapter 3

# FRAMEWORK TYPES USED IN POLAND

### 3.1 WOOD FLOORS

---

In the history of the building known "forever" and used already by the early builders. Often simple, made intuitively, without the static calculations. Fulfill its mission in the country cottages, and as a work of carpentry and sculpture still separate floors of the royal palaces. For decades, designed and executed with precision engineering. Over the centuries have not changed the rules for their construction. Have a high tolerance for incorrect sizing, but require careful implementation. Despite the development of other building materials and related technology regulations, the wood is still commonly used building material.

#### Components of the wood floors

Timber beam wood is used mostly as attic floors or ceilings system between buildings. The skeleton of the floor consists of wooden beams and joists. Floor structure elements based on the load-bearing walls. However, the same substrings in addition to reliance on the walls of a building can also carry loads through the poles. Wooden ceiling beams are made mostly of solid wooden beams. You can also perform as part of folding beams (glued or bonded mechanically).

Beams should primarily meet the requirements for load capacity and stiffness of the system. Sizing of elements depends on the expected load of the floor. The beams should have a thickness of 42 mm, which provide sufficient rigidity to prevent twisting of the elements. The amount depends on the beams span the ceiling, beams and the spacing of the class and type of wood. Typically, the ceiling beams arranged on the walls of the building on special rootstocks (brick buildings) or so. grounding. Commonly used two beams spacing: 40 or 60 cm. In addition, the brick buildings of the floor beams shall be protected against "using a special yoke. Length of the unsupported section of the floor beams (part of "hidden" in a niche in the wall) must match the length, height of the beam. Additionally, for the security

part of the structure before bringing in a niche of moisture, seal the wood preparation bitumen and wrap a layer of tar paper. Niches in the wall should be constructed in such a way that placed it around the wooden part was a 2-3 cm layer of air. Moreover, the layer felt pad should be separated from the wall.

Another important detail of the support beam is to leave gaps between the beams and the wall face. To extend the life of wood (to prevent condensation of water vapour) should also follow the thermal insulation of the nest. In the case of construction top floor is often fastened to the beams lying on the wall (and fixed to it) foundations. In this case the beams attached to the forehead might be called. The front cross member, whose task is also a rigid system of beams. In practice this is often necessary to comply with the ceiling so that they can pass through the other elements of building construction such as stairs or chimney. It is not possible then the normal behaviour of the ceiling beams. Then it is necessary to reduce the load transfer beams and the adjacent elements through the beam. This beam is fixed with the yoke of both beams summary and full-dimensional beams. In the case when the hole runs across a few (3 or 4) of the floor beams is necessary to implement the first full-dimensional beams at the opening, as the dual beam (juxtaposition and interconnection of two typical beams.) It is important to maintain adequate distance between the beams such as penetrating through the ceiling chimney. This distance shall be not less than 25 cm. Wooden ceiling beams do not require concentration. On the contrary, over-complication of the structure can lead to creaking floors, as a result of bad handling stress.

Among the wooden ceiling seems to be the most effective arrangement with headliner and partial filling in the spaces between joists with mineral wool (Picture 3.1.1). With low complexity, it provides adequate noise insulation and reduces heat loss. As the system between the ceilings in residential structures shall be of a more complex system. Usually part of the "interior" ceiling slab is blind. Its mission is to provide a platform for the implementation of insulation (and also acoustic) ceiling. In addition. Thus there is no moisture insulating material and is not followed by the accumulation of moisture within the roof space.



seems that the wet technology works and the burden resulting from the weight of the solid material is simply bad. Bare floors is normally used in farm buildings (Picture 3.1.2).

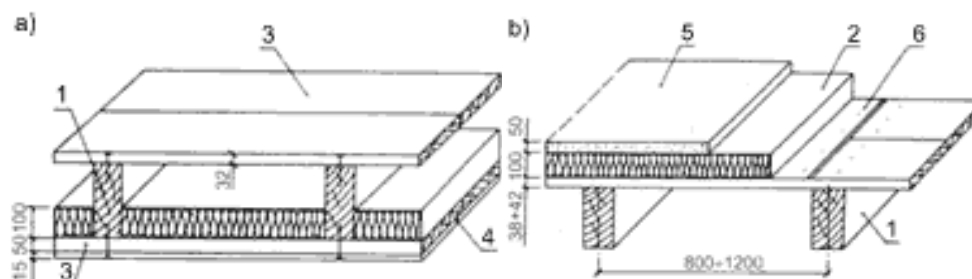

Picture 3.1.2: Wooden ceiling beam: a) the floor and the headliner, b) bare, insulated from the attic, 1-beam, 2-wool, 3-board, 4-plaster, 5-improv, 6-papa or film.

### Principles of design

By joining the design of the wooden floor, remember a few basic principles. Above all, be taken into account shrinkage of wood. If we use a highly humid building materials, it is the long-term operation of the component, there is a change (decrease) in its dimensions. The effect of changes might be turning a joist or soffit space warping or floor. Can be particularly dangerous shrinkage beams joists. The way to combine them with the walls of the building construction can, in extreme cases even lead to their damage (walls perfectly withstand the vertical, but are much less resistant to forces acting perpendicular to its axis). Dimensioning of beams can be made on the basis of calculations made taking into account the static PN-81/B-03150 requirements of the standard or using a simplified method based on the available tables in the systems for buildings "Canadian" (National Forest Product Association). Practice has shown that the most commonly used height of the floor beams of 180, 235 or 285 mm.

### Advantages wooden floor

The main advantage is the lightweight wooden floors to their construction, while at the same time high in relation to the weight of its own strength parameters. Certainly beam ceilings are perfectly suited for residential buildings, single family. Represent an ideal solution for constructing the floor of the attic. Properly designed and constructed in accordance with the rules of the trade, for decades can serve its function. Furthermore, it is important that the wooden ceilings are made in the technology of dry, taking into account national climatic conditions, allows the execution of the floor for periods of low temperatures. Moreover, there is significant ease of the floor structure and the possible overhaul of the structure.

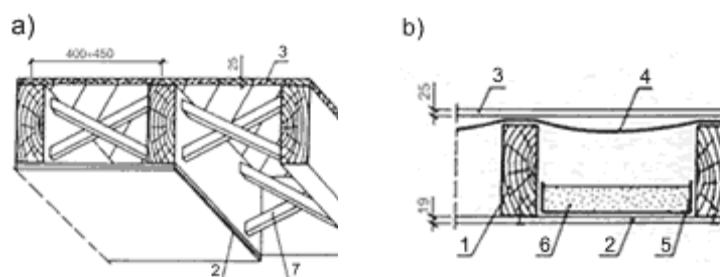

Picture 3.1.3: Ceiling board: a) without thermal insulation, b) with thermal insulation, 1-beams, 2-soffit, 3-floor, 4-fibreboard, 5-papa, 6-improv, 7-struts.

Practice has also shown remarkable resilience of the wooden ceiling insulated with mineral wool on fire in extreme situations. Of course, the use of this type of technology necessitates the construction of the roof light walls. In addition, places considerable demands on water and sanitation installations and electrical in the building.

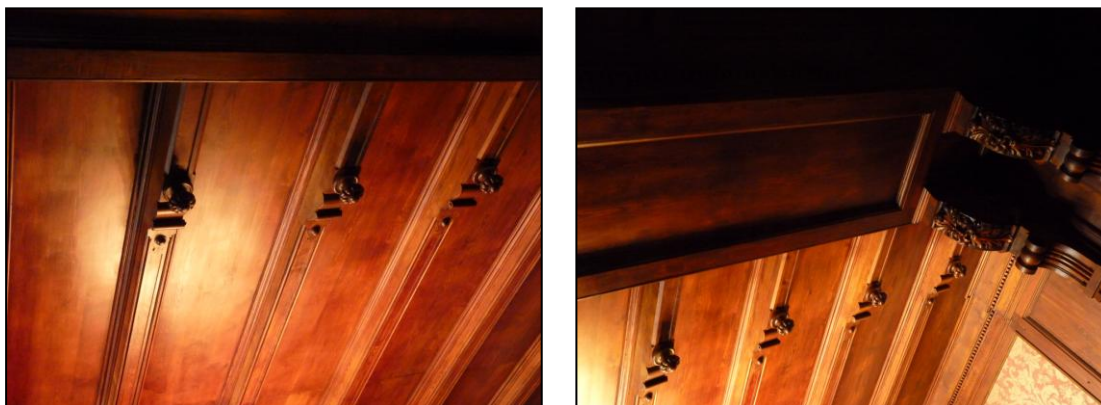

Picture 3.1.4: Ceiling of Art Museum of Gliwice.

Source: Own picture.

## 3.2 MONOLITHIC FRAMEWORKS

### 3.2.1 ACKERMAN, CERAM, CERIT, FERT...

Ceiling Ackerman, Ceram, Cerit, Fert... are widely used in Polish construction monolithic slab filled with a stiff and durable. Filling a hollow ceramic ceiling height of 18 and 20 cm. Spacing of the ribs of the floor is 31cm, width calculation rib 7 cm, thickness of the upper concrete slab 3 or 4 cm, depending on

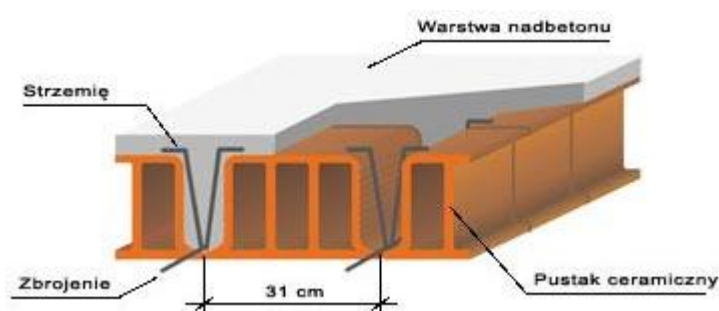

the value and type of variable load.

Cross-section of brick wall is not included in the section of the carrier rib. Weight m<sup>2</sup> ceiling of 3 cm concrete slab top is the application of hollow height

18cm-2.65 kN/ m<sup>2</sup>;20cm-2.95kN/m<sup>2</sup>.

Picture 3.2.1.1: System Ackerman

Source: <http://stroop.webpark.pl>

If the load is less than 1.5 kN/m<sup>2</sup> ceilings can also be carried out without the top plate of concrete.

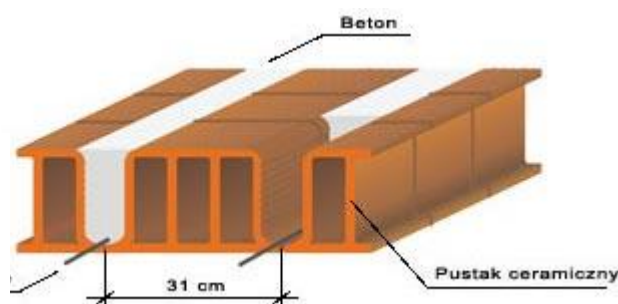

### Work placement:

After bringing the walls up to roof level and their isolation, it joins itself to the scaffold formwork for the bricks and Ackerman. Apply stamps of logs with a diameter of not less than 14 cm. Fits them laterally (bolts) with thick planks at least 38 mm. Stamps should be braced with boards with a thickness of 24 to 32 mm.

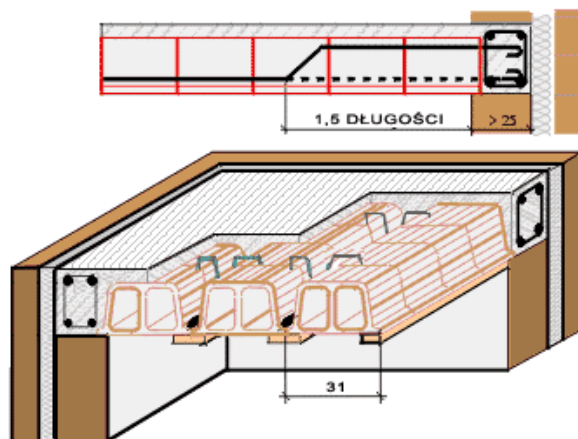

For formwork beams arranged with clearances, arranged in such a way that coincides with the rib board. The level of the formwork is adjusted by raising or loosening of wedges under the punches. When the floor is a basement, stamps should be placed on the backing board with a thickness of 38

mm. Under the set of stamps already made the lower floor ceiling can not use pads with wooden planks.

**A wreath made of reinforced concrete:** is performed around the building exterior walls



and internal load-bearing, contributes to stiffening the walls of the building and reduce the deflection of the floor. Reinforced with four bars of a diameter not less than 10 mm. Shackles the rims are made of round bars with a diameter of 4.5 ÷ 6 mm. The ribs are made after laying bricks, they are wired in the traditional manner, one rod with a diameter of not less than 10 mm. Every second bar bottom reinforcement rib is approximately one fifth of the floor span bent upward and anchored on the extreme rim reinforcement.

*Picture 3.2.1.2: Wreath made of reinforced concrete.*

*Source: <http://stropy.webpark.pl>*

Stirrups are made of round bars with a diameter of 4.5 to 6 mm, and spaced every 30 cm. They are concentrated at the supports, if necessary due to lateral forces. At small loads (eg floors of residential buildings) and the careful execution of the construction can not use stirrups in the middle span (the span of about 0.6).

#### **Reinforcement ribs main:**

As the main reinforcement rods of the ribs should be applied with a diameter of not less than 10 mm.

Applicable bar diameters (steel ribbed Class A-III grade 34GS) depending on the span of the floor are:

- From 3.00 m - 10 mm
- 3,00 4,00 m - 12 mm
- From 4.00 5.00 m - 14 mm
- From 5.00 6.00 m - 16 mm

Note: The distributive stirrups and rods used to be rods with a diameter of not less than 4.5 mm. Stirrups can not execute in the ribs with a span of not more than 5.5 meters (subject to appropriate wrapping myself with concrete reinforcement bars, and that calculation does not require shear reinforcement).

Stirrups are required for a span of more than 5.5 m (at least 4 stirrups at supports at intervals of not more than 33 cm).



Reinforcement ribs key to enter the edge of the support - in accordance with PN-84/B-03264 where:

- ribs do not require the calculation of reinforcement stirrups - the length of at least 5 diameters of reinforcement,
- require computationally rib reinforcement stirrups - the length of at least 10 diameters and a length of 15 diameters if cross-sectional area of bars brought to the support is less than  $2/3$  cross-sectional area of reinforcement in the middle of the span.
- require computationally rib reinforcement stirrups
- the length of at least 10 diameters and a length of 15 diameters if cross-sectional area of bars brought to the support is less than  $2/3$  cross-sectional area of reinforcement in the middle of the span.

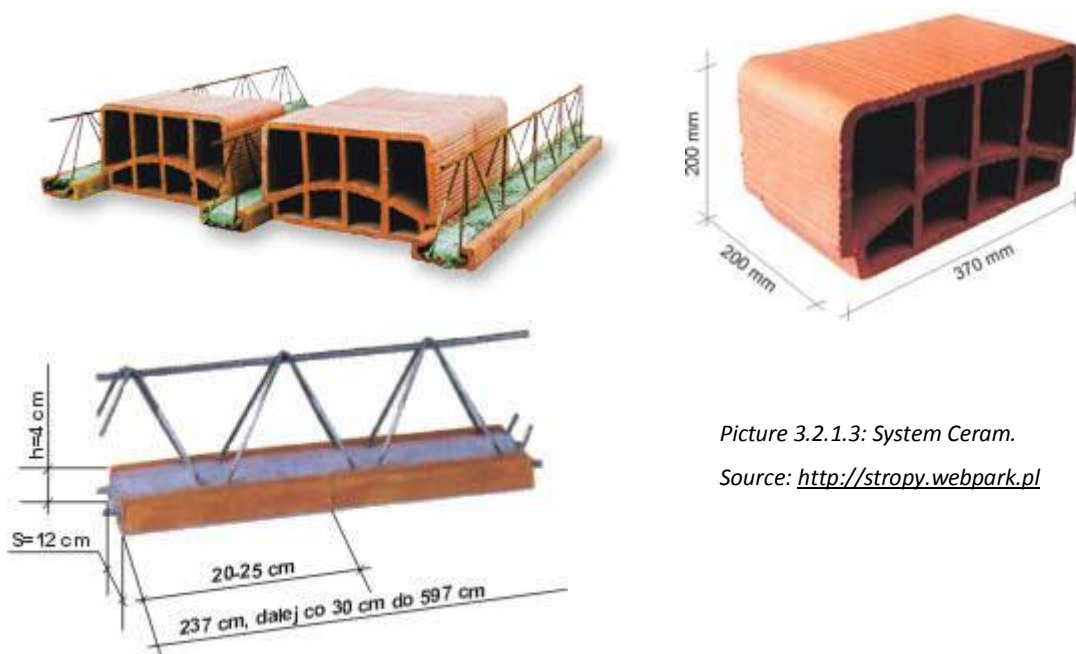

Picture 3.2.1.3: System Ceram.

Source: <http://stropy.webpark.pl>

## SYSTEM FERT

Fert concrete slabs are on site eg closely ribbed ceiling ceramic-reinforced concrete. They are used mainly in housing construction. Prefabricated beam ceilings create a ceramic-reinforced concrete, structural clay tiles, concrete ribs and slabs paved.

Fert prefabricated beam type structural ribs are ceiling and consist of:

- Lower waist made of ceramic with a width of 12 cm, height 4 cm and a length of 25 cm;
- Reinforcement composed of three steel bars (2 bars in the lower waist and 1 rod in the upper lane) and medium steel stirrups. 4.5 mm, arranged in a triangular lattice, connecting the upper reinforcement with reinforcement of the bottom. In the span of 4.2 m above the floor - lower zone stretched in Fert-type beams 45 and 60 is reinforced with an additional one or two steel bars. This treatment is used to obtain the total load limit for the projected span of the floor;
- fill the lower rib foot ceramic concrete aspects as a Class B 20th Mass of 1 m beam is 12,30-14,08 kg. The upper part of the rib and concrete plate after positioning beams and hollow concrete class B 15 with Portland cement brand "35" and the class aggregate of at least "17", a fraction not greater than 10 mm. Choosing ingredients of concrete should be recorded in the log construction. Fert beams should always set a ceramic foot down. The beams are placed in the ground on two wooden chocks, a thickness of at least 8 cm, spaced at a distance of  $1 / 5$  length (range) calculated from the end of the beams. The next layer of beams arranged on supports at least 3.8 cm thick, fold vertically above the lower layers of pads. The pile should be in the beam of equal length.



During transport the beam tightly arranged next to each other in their length direction, the horizontal layers to a height of two layers, and at the construction site to a height up to 5 layers. On bumpy roads, cars should move carefully and slowly to avoid cracks occurred feet lower beams and lattice strain of reinforcement beams arranged in the lower layer. The beam is raised by circles nodes within the belt of the upper fifth span measured from the ends of the beams. It is unacceptable to raise the bar of the upper beams between nodes.

Produced blocks have a length of 30 cm, height 20 cm, while width varies:

- Fert-40 - 32 cm,
- Fert-45 - 37 cm,
- Fert-60 - 52 cm.

## Laying bricks



At the bottom of the notch blocks are adapted to lay on the foot beams. For the transport of holes should be arranged vertically, the bases themselves and the longer side in the direction of travel. Medium trucks, the individual layers and the free spaces between the bricks and walls should be filled Body lining material (straw, wood chips) of thickness 2 cm. Hollow bricks should not protrude above the top edge of the car for more than 10 cm. They should be protected against the possibility of reciprocal transfers.

To carry out, the ceiling should be applied and all blocks filled (especially the lower rebate). Minor damage to be filled and sealed with cement mortar before concrete and slabs of ribs (because then he could pour the concrete into the interior of blocks, resulting in increased weight of the ceiling).

Hollow bricks at the top tightly arranged next to one another, so that the cutting surfaces adjacent to each other exactly. Elements of the extreme (with reinforced concrete ring beams and distribution ribs) should be from the hole closed by the concrete cap, securing them before pouring the concrete mass inside. Capping of blocks is performed on the backing of the boards, which set them vertically drilled and then filled with cement mortar to a depth of about 2 cm.

The length of the back beams on the walls and supporting binders should be at least 8 cm. The beams in the roof is laid on the setting, levelling, and stamps stiffening of boards with a thickness of 38 mm, arranged at the walls and supporting binders and intermediate supports.

Props intermediate must be located: one in the middle of the floor beams with a span of up to 4.5 m, two in about 1 / 3 the length of the span of the floor 4,5-6,0 m.

Stamps carefully removed after the concrete has set, but no earlier than 14 days after the completion of concreting the entire ceiling. Beams on the wall is based on rims through reinforced concrete. They are reinforcement steel rods with a diameter of 10 mm and stirrups of 4.5 mm diameter at intervals of 25 cm.

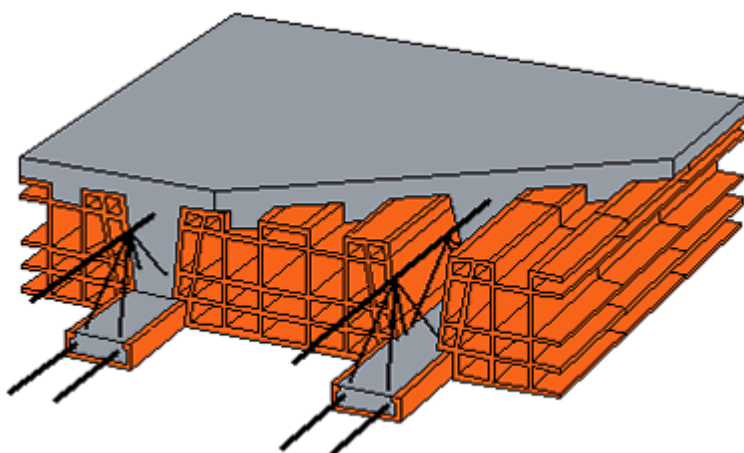

In order to thoroughly protect the spacing between the axes of the beams at 40, 45 or 60 cm and provide good support blocks on the lower flanges of beams and rigid, it should be between any two beams - at both the ends - to arrange one with a crown of concrete brick. In the span of more than 4.5 m should be given one more block - in the middle of the span of a beam or two blocks - in separating rib, stiffening the ceiling in the direction perpendicular to the beams.

Hollow bricks should be put to work platforms made of planks 38 mm thick. Hollow bricks should not be based on the walls, which are stacked beams. Laying the beams should be started on those elements that are intended to rib the partition walls (parallel to the direction of beams.) Rib in this place should be strengthened by laying next to each other two beams, or in the manner specified in the design of the floor.

With the modular roof span of more than 4.5 m, do in the middle span of the roof rib distribution width 7-10 cm, reinforced with two steel rods no less than 10 mm. Sectional rods - top and bottom - should be together as much as the bottom section of the reinforcement in the beam. Both bars separating the rib (upper and lower) are connected by stirrups dia. 4.5 mm, spaced at intervals of 40 cm - in ceilings Fert-40, at 45 cm - in ceilings Fert-45 and 60 cm - in ceilings Fert-60.

#### Concrete slab

Concrete ceiling after laying the reinforcement ribs in the ring beams and panels, straightening of the reinforcement in precast beams, clean and abundant water sprinkling of arranged elements. Mix concrete beams, rib, plate and wreaths - the concrete mix is to be plastic, just condensed.

Concrete needs to be nurtured, particularly in the period of elevated or reduced temperature.

Transportation on the roof of the concrete mix can be carried out in wheelbarrows with a capacity of 0.07 m<sup>3</sup> of boards on the catwalks of 38 mm thick, lying perpendicular to the stacked beams. Bridges should be covered with protective strips on the edges against rolling wheelbarrows.

### 3.3.2 JS FLOOR

Styrofoam plate type JS is shuttering element in the implementation, the cheapest way, floors, roofs, etc. in single and multi-family buildings and industrial facilities and commercial.

There are three types of plates of different heights and widths which allows you to design rooms. Three types of formwork panels and styrofoam plates allow the design of the five types of ceilings of different thicknesses of reinforced concrete slabs, poured in the formwork. In addition to significant financial savings resulting inter alia in the absence of additional thermal insulation capacity of

the roof installation, roof installation without the use of cranes and shuttering (at the time of reinforcement and pouring of the floor, styrofoam formwork panels are supported only punches that we remove the ceiling when it gets full strength - it gives us a 100% recovery of precious wood), the use of the above boards can reduce the installation time of the floor consequently, the construction time.

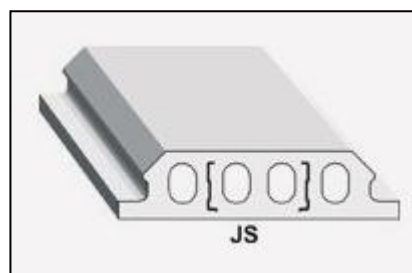

Picture 3.2.2.1: System JS

Source: <http://www.gaik.pl>

An additional advantage of the floor made using expanded polystyrene formwork plate its weight is about 200 kg / m<sup>2</sup> which reduces the burden on the benches by almost 20%. Lightweight roof makes it possible to apply it in the construction of sandy land, wetlands, etc.

EPS formwork panels are used as formwork for high thermal insulation and sound. Not an element of transfer external loads. The external loads are carried by the beam and the concrete slab floor.

## 3.3 PRECAST

### 3.3.1 FILIGRAN

#### Features

Ceiling FILIGRAN type is a universal system of reinforced concrete slabs, used throughout Europe. Thanks to their excellent structural solutions in the prefabricated construction method adapted to industrial, residential, rural and do not limit the overall creativity of architects.

Prepared in a factory prefabricated thin reinforced concrete slabs, which are part of a composite reinforced concrete floor, have a thickness of 4,5-7 cm. Are steel reinforced spatial lattice structure and additional bars are situated parallel and perpendicular to the trusses. By design (thickness and the amount of lattice girders), the total height of the ceiling together with a layer of concrete overlay shall be not less than 12 cm. Steel trusses are located parallel to the long side of the plate at a spacing of not more than 0.75 m in monolithic layer of concrete - the building - arranged additional reinforcement, such as reinforcement for the support. The fusion of two layers of floor - precast and monolithic - provide partially filled with concrete, steel trusses in the roof space and the rough surface of prefabricated panels.

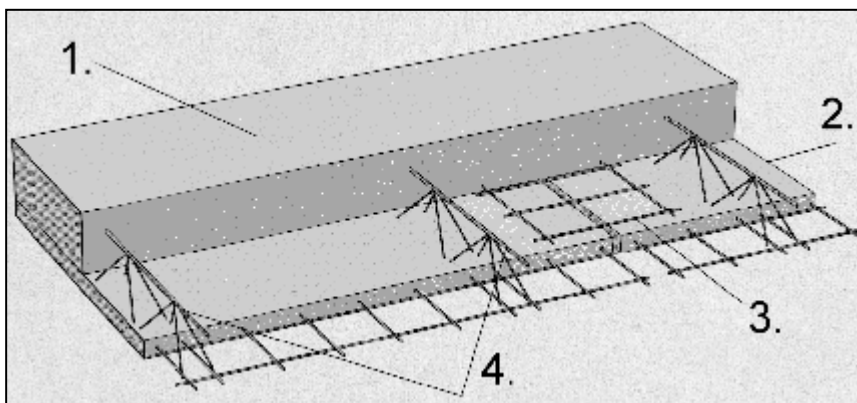

Picture 3.3.1.1: Filigree-type design of the floor. Notations: 1-Laid on the construction layer concrete overlay, 2-Prefabricated plate, 3-Panel joint reinforcement, 4-Steel trusses space.

Steel trusses are suitable motherboards prefabricated rigidity during transport and during performance of the floor.

The shape of the plates, and thus the shape of the roof may be completely arbitrary: rectangular, triangular, trapezoidal, semicircular, curved, irregular, etc. The CD also included all the

necessary holes and notches on the edges of plates provided in the documentation, such as holes in the chimneys.

Also free to adopt the dimensions of prefabricated panels. However, due to transport (the maximum permissible width of the moving vehicle transportation elements), a length of the plates from 2.40 to 7.80 m and width from 0.60 to 2.50 m. The maximum width of the panels is 2.70, and the length may be as high as 12.00 m.

### **Work placement**

Panels are transported to the building and there - in accordance with the attached draft assembly drawings - mounted crane. One car carries about 150 m<sup>2</sup> discs. Project cost and transport cost are included in the total cost of the floor. The supply of prefabricated panels can be ordered for a specific time, so you can, but need not be stored on site - can be installed straight from the wheels. "Weight 1 m<sup>2</sup> plates 5 cm thick is about 125 kg, a plate of dimensions 2.50 / 6.00 m weighs about 1875 kg.

Before installing the panels have to prepare a support Mounting: place them in a span specified in the design and level. On the fixed support (for example, walls) layers of cement mortar 2 cm thick. Some manufacturers allow (if the depth of the base plate on the support is less than 4 cm) stacking plates directly on the support.

On the fixed support so prepared and arranged the mounting plate. Assemble them in three persons: one supports the crane, and two adjust the plates at the supports. The number assigned to each board facilitates its location. Then arming wreaths and puts additional reinforcement layer monolithic provided in the project. The holes in the roof shall be prevented from completing a mix of concrete: smaller holes - Styrofoam, and more - with boards. Trusses light passing through the hole left in the precast until the removal of the support assembly, and then felled.

After mounting the reinforcement, plates or elongated pins (pictured), mesh or rods (minimum reinforcement: rods 6 mm in diameter, length 0.48 m 0.30 m spacing). This reinforcement prevents dowelling, or uneven deformation of the individual pieces of the ceiling. On the structure of such prepared layers of concrete class C20/25 minimum, performing at the same time wreaths on the walls and beams. Walls can be built higher floors before the roof - after 28 days - get full strength.

### **Advantages**

- High accuracy and smoothness of the floor does not require plastering.
- Strength of plates adapted to the individual charges, in accordance with the terms of use of the ceiling.
- The production ceiling for the construction requires a minimum of formwork (shuttering).
- Ability to perform any shapes, such as circles, triangles, polygons, etc.
- Ability to perform on stage all the prefabricated openings (ventilation, plumbing break, etc.)
- Low dead weight plates with a thickness of 5 cm - 125 kg / m<sup>2</sup>.
- Simple and short construction period.
- Possible to assemble a car with no intermediate storage (according to project documentation.)
- Correspondingly little is also a demand for land facilities on site.
- Universal application in all types of construction.
- The limitation on the assembly floor, the elimination of formwork  
Reducing the amount of workers needed for the preparation of the floor.

### **3.3.2 BEAM-PLATE**

#### **Advantages of precast slabs**

Prefabricated slabs have a reputation for fairly expensive solution - is wrong. Their use may lead to the elimination of duplication of the financial costs of construction delays and the need for continuous overseeing a repair crew.

Another advantage is the fact that the roof can be used immediately after installation, so you can immediately continue working, which leads to further savings in time.



*Picture 3.3.2.1: Prefabricated ceilings give a great saving of time.*

*Source: <http://www.dom.pl>*



In addition to time savings from using this solution have a clear, undeniable benefit - safety. In the safety of the building consists of, inter alia, its resistance to fire. It depends on many factors, such as the design of the facility, its equipment and materials from which it is built. Only non-combustible construction materials do not pose a threat when in the vicinity there is a fire and in no way contribute to the development of a fire.

For refractory materials include, inter alia, concrete and steel, so you may want to choose the ceiling made from these materials, you should also find out whether it fire resistance class R 30 (material with low flame spread) or R-90 (refractory) - if so, then you know that meets European standards for fire safety.

### **Application**

The use of precast slabs allows you to connect together two factors equally safe counts and execution time. Can be used in various types of buildings, both in blocks and houses. This allows for considerable savings in time and money, which usually absorbs the classical construction of the floor.

Shuttering for slab of monolithic slabs is the product enjoys a high thermal insulation, lightweight construction by placing items inside the styrofoam plate while maintaining optimal thickness.

### **3.3.3 PSKJ-S**

Floor slabs PSKJ type-S are designed for prefabricated-monolithic ceilings in residential, industrial and public buildings. The technology is extremely comfortable and on the occasion of lowering construction costs. Plate is a structural design of reinforced concrete, for which the individual is calculated carrier distribution of reinforcement in the form of special trusses. Trusses protrude above the top surface of CDs and cooperate with them during transport and installation.

Ceilings Record PSKJ-S are monolithic floors consisting of two main structural components, namely:

- of prefabricated concrete slabs with a thickness of 5 cm, called structural and plate shuttering
- supplementary layer of concrete (13 cm) cast on site to a height of 18 cm and the total length of the plate to 6.0 m.

Such ceilings while taking advantage of monolithic and precast floors. With a length of plates from 6,6-7,2 m total height of the floor is respectively 22 and 24 cm. Standard CD-S PSKJ are manufactured to the span of 7.2 meters and width of 1.2 m, 1.8 m, 2.4 m, in two versions, with a net weight of its own, without the characteristic 4.5 kN / m<sup>2</sup> and 7.5 kN / m<sup>2</sup> .

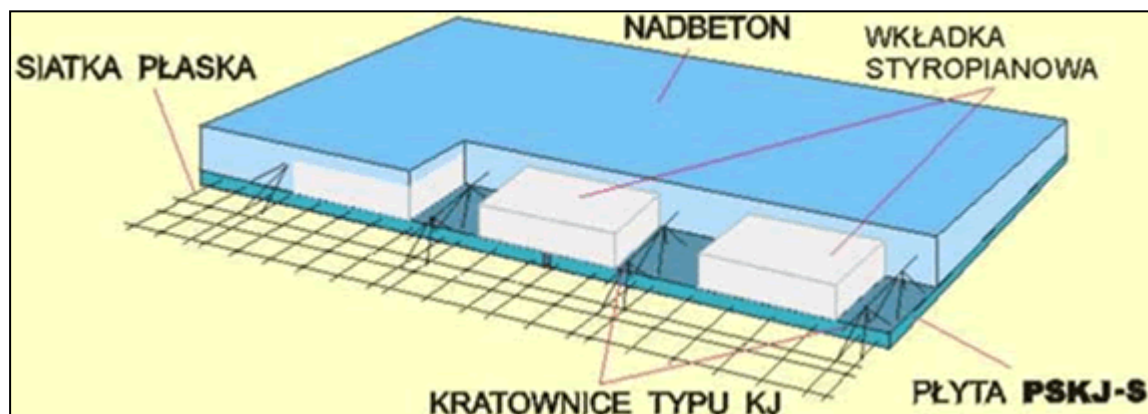

The main tension reinforcement, reinforcement distribution as well as a KJ cranes must be made of steel A-III, N. plate shuttering PSKJ-S is made of concrete, Class B-25. Concrete accompanying CD to the appropriate height should also be in the class B-25. Technical parameters range - up to 7.2 m width max - up to 2.4 m thickness - 5 cm thick slab - 18 to 24 cm load characteristics - 4,5-7,5 kN.

Are also produced special plate width of 0.6 m, heavy oblong (12 cm), dividing walls and the typical length of the manufactured discs. Thanks to these motherboards can be avoided by the use of expensive and time-consuming formwork for the implementation of monolithic slabs, and the smooth surface of the bottom plate allows you to paint the ceiling without additional plastering. CD is characterized by a low dead weight (ca. 120 kg / m<sup>2</sup>) and can be mounted directly on the site of the "car". Manufacturers also offer the possibility of producing panels of technical documentation supplied by the investor, taking into account different sizes, shapes, plates, cut the holes, etc. The use of CD technology accelerates the cycle of investment in relation to traditional methods by about 40-50%. Disc production technology ensures perfectly smooth bottom surface, which eliminates plastering. Puttied only connection plates. Welded mesh panels to prevent dowelling of connections. Implementation involves installing ceiling tiles and concrete breaks addition, because floor slabs 5 cm thick with the main reinforcement are also span slab formwork. Therefore, this technology eliminates the costly formwork. On the occasion of the aesthetic appearance is achieved without the need of ceiling plaster. Slings allow you to carry out works at low temperatures.

# Chapter 4

## FRAMEWORK TYPES USED IN SPAIN

### 4.1 UNIDIRECTIONAL AND BIDIRECTIONAL FRAMEWORK

---

We can classify frameworks depending on the disposition of the loads in: unidirectional and bidirectional.

**The Unidirectional Slabs** are those who support or join to the supporting structure through the edge, main beams and beams where the resistive elements are arranged in one direction. On the other way **Bidirectional Slabs** are plates (surface structures), flat, working with torsion and bending in two directions, and because of its support and provision of armor work in two directions. These plates can be solid or lightweight and we will discuss about them later.

The Unidirectional Slabs, consist of several elements: resistive elements, the elements of infilling between slabs and the compression layer.

According to the material that forms the resistive element, the structural floor takes the name of this material.

Within the unidirectional slabs we can find made of wood, metal or concrete.

The elements that constitute these floors are:

The concrete filled in situ to fill nerves and the upper slab (layer compression) which has the mission to transmit the loads to the joists.

Reinforcement:

- Active and passive reinforcements (rebar rods)
- Welded steel mesh that are placed on top of the slab, embedded in the compression layer and serves as a distribution of loads and prevent shrinkage of the concrete.

The tie-beams, which can be:

- Resistant or autoresistants (prestressed beams)
- Semiresistants (prestressed beams)



Picture 4.1.1: Autoristant prestressed tie beam  
Source: <http://www.viquetasnavarras.com>



Picture 4.1.2 Reinforced tie beam  
Source: <http://www.previerval.com>

Infilling elements (joists filled block), that are based on:

- Lightening the weight of the slab.
- Serving as permanent formwork to the concrete slab above.
- Developing a cross-bracing the joists.
- Encouraging the thermal insulation of the floors acting as air chambers.
- Serving as a support element for the lowercovering.
- They are made of ceramic, lightweight concrete or Styrofoam



Picture 4131: joists filled block ceramic and lightweight concrete  
Source: <http://vigatec-eirl.com>

## 4.2 PREFABRICATED FRAMEWORKS

### 4.2.1 ALVEOLAR SLAB

#### Features:

- The slabs, as shown in the following images are from the resistance point of view, unidirectional, i.e., they are characterized by resistance to bending in one direction, due to their support and provision of reinforcement.



Picture 4.2.1: Alveolar slab plate.  
 Source: <http://esp.prefabricatspujol.com>

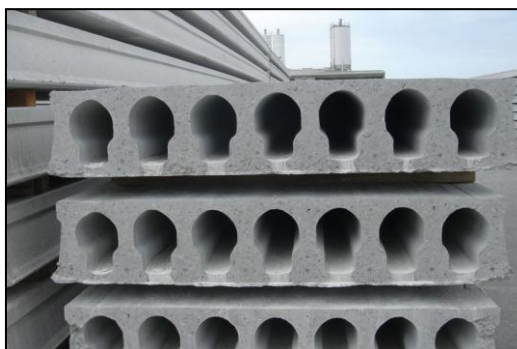

Figure 4.2.2: Alveolar slab plate.  
 Source: <http://esp.prefabricatspujol.com>

- The framework of hollow core slabs comprises large and heavy parts. They usually have a width of 2.40m as the width of the normal truck transport. However, the limitations of the lifts make the widths are smaller. Are widely used 0.8m and 1.20m submultiples both of 2.40, which allow full utilization of the truck.
- The lengths reached are more variable and can exceed 30m and the height / span is usually between  $1 / 25$  and  $1 / 30$ .
- The pieces have 2 flat faces and two longitudinal perforations. The flat sides provide greater inertia that can achieve greater equality of edge lights or reduction of edge with the same light. Longitudinal perforations allow lighten the weight of the slab.

Formerly the most widely used drilling was circular but today, as shown in Figure 4.2.3, we can get a better lightening for window round arch sections and partition walls of 2.5 or 3cm thick (but more effective in reducing weight is obtained

drawer panels, made of large rectangular holes). Perforations are commonly used to house inside water facilities, heating, electricity.



Picture 4.2.3: Design alveoli of the slab.  
Source: <http://esp.prefabricatspujol.com>

- The different plates are supporting then pouring concrete into a receptacle called a ball and socket joint located between the edges of a plate and the next. Thus is ensured the transmission of lateral loads. In this way we will transmit only shear forces and not bending moments.
- It has a compression layer on site thickness 5, 8, 10 and 15 cm housing a corrugated steel mesh. The lower longitudinal reinforcement of the alveolar plates are made with diameters of 4 and 5 mm of prestressed steel.



Picture 4.2.4: compression layer of corrugated steel mesh  
Source: <http://esp.prefabricatspujol.com>

- Plates should be mounted at least 4cm on the factory walls or on the board of formwork or precast girder.



- It has easy maneuverability, simplicity and speed of execution, as seen in the figure below.
- It is difficult to make corrections once already in work.
- It offers greater job security.
- It is not needed to look for solutions to get a good finish bottom.
- Geometric conditions to be met:
  1. The edge of the slab must be  $\leq 50$  cm. The width without reinforcement allocation should be  $\leq 140$ cm, and  $\leq 250$ cm when we have delivered reinforcement.
  2. The lights should not exceed 20m, as shown in the illustration below.
  3. The minimum thickness of souls should be:
    - $\leq (2H)^{1/2}$
    - $\leq 20$ mm
    - $\leq$  maximum aggregate size + 10mm
  4. The minimum amount of reinforcement should be 1.5 per 1000 of total section and a 5 per 1000 on a cobaricentric area over the bottom reinforcement.
  5. There must be a minimum of 2 wires placed symmetrically.
  6. The separation between tendons must be 40cm and  $\leq 2 \times$  edge.
  7. The minimum cover must be  $\geq 15$  mm and it is set as a measure of corrosion protection for the prevention of longitudinal cracks and fire resistance.
  8. The minimum execution overhead should be  $\geq 1.0$  k / N / m<sup>2</sup>.
  9. The arrow must be total less than L/250 or L/500 +1 cm. In case of roofs that support very rigid walls, or L/1000 L/500 +0.5 cm.
  10. For lights under 12m and under 4kN/m<sup>2</sup> overloads can get with a formula an edge in which there is no need to check deformability.



### **Applications:**

- Heavy overloads and / or spans, car parks, warehouses, industrial work, shopping centers, entertainments ...
- Modular construction: hospitals, schools, office buildings, residential consecutive construction ...
- Civil works: pedestrian walkways and small bridges, tanks covering and canals ...
- Inclined and vertical slabs: large span roofs, walls of buildings, retaining walls and screens ...



*Picture 4.2.5: Parking and Warehouse made with hollow core slab.  
Source: <http://esp.prefabricatspujol.com>*

### **Work placement:**

The manufacture of these elements can be static or stationary, where the position of the mold is fixed and jobs are mobile.

The manufacturing chain is characterized by the panel, placed on a dolly or wagon, is shaped through a series of jobs which makes one or more of the following steps: cleaning the mold, release agent application, placement of components, concreting, vibrating, curing and removing the piece.



Once the piece is done, it is removed from the mold and gathered in the park. These operations, as well as mounting works are performed by additional reinforcement.

We have to take into account that :

- The lighter parts, are hooked by their temper or negative reinforcement.
- The major pieces are moved with the help of lifting hooks and also flowtube in which is inserted a steel rod.
- In the manufacture of large panels, are embedded caps that are screwed to the slings. and also studs.

Other prefabricated are rised :

- Directly via cables in the form of bonds (the point of care should apply for reasons of stability, sliding safety and protection of the corners).
- By expansive rawplug (difficult and slow solution through the hole in hardened concrete that is only used when they are broken or forgotten lifting trusses).



Picture 4.2.6: Positioning System alveolar slab

### **Construction details:**

The union of the slabs with beams or bearing walls is a function of the conditions of support for the formation of a composite section, the behavior against external horizontal loads, the tolerances of execution, etc.

In the pictures below see the joints in the slab with steel beams and walls of ceramic bricks. They detail the support systems

## BEARINGS ON SHELF ANGLES

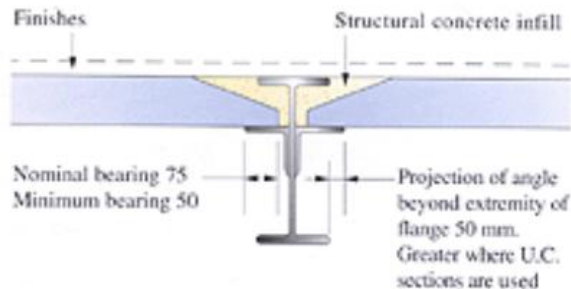
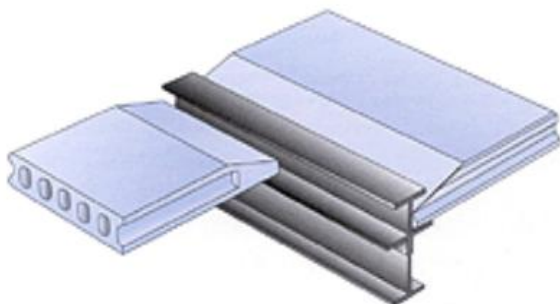

25 mm clearance is required to allow unit to be dropped into position past the flange of the supporting U.B.

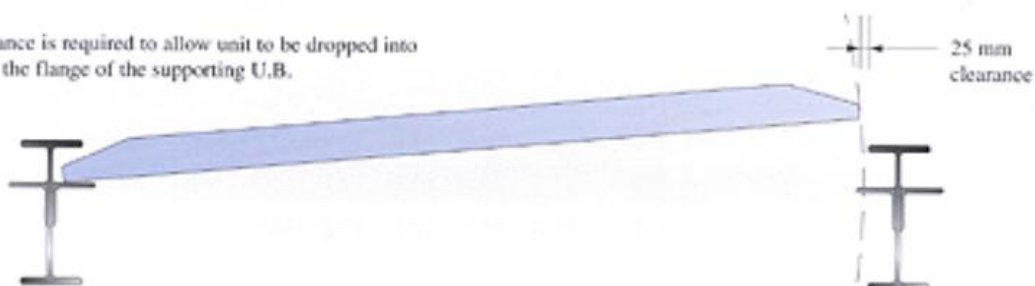

## BEARINGS ON MASONRY

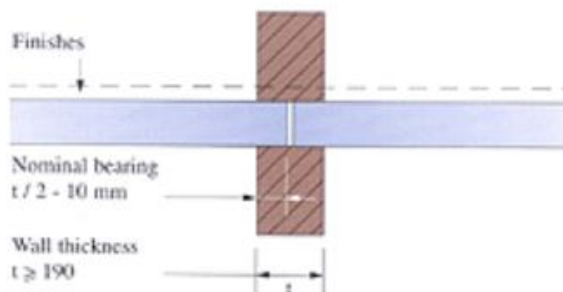
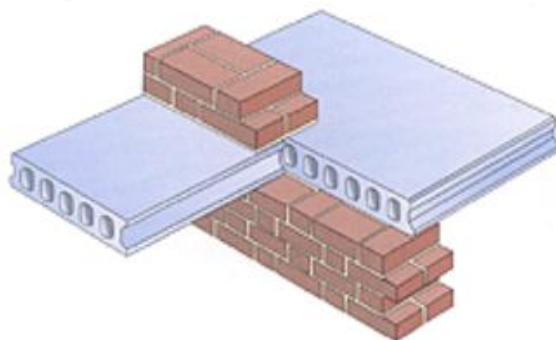

## SIDE BEARING

Where required by Building Regulations for sound insulation.

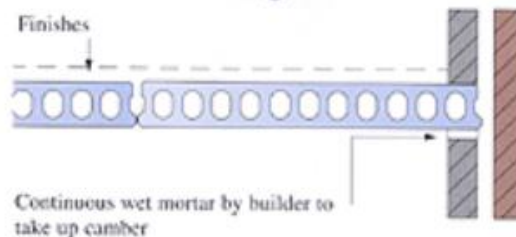
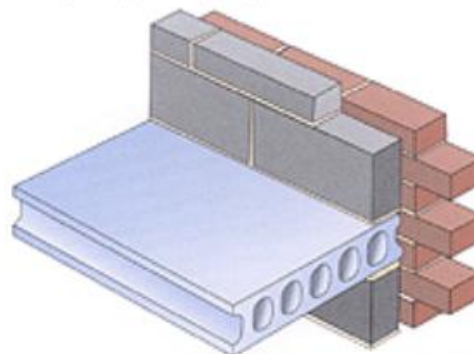

### NARROW WALL BEARING

(NB. In order to satisfy the tolerances in this situation, this detail is only recommended where a full bearing is available at the other end of the slab)

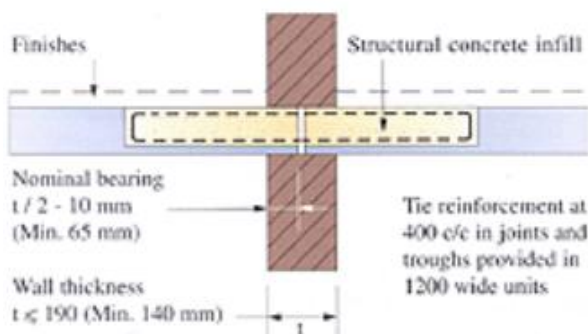
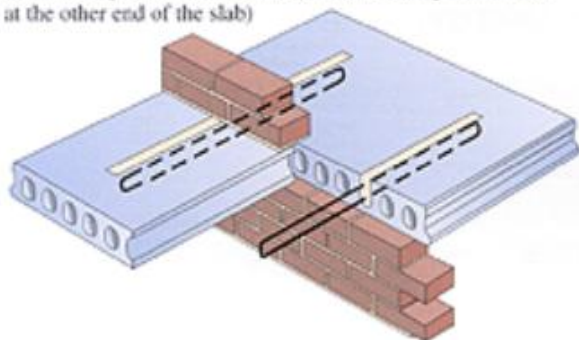

### NARROW BEARING ON STEELWORK

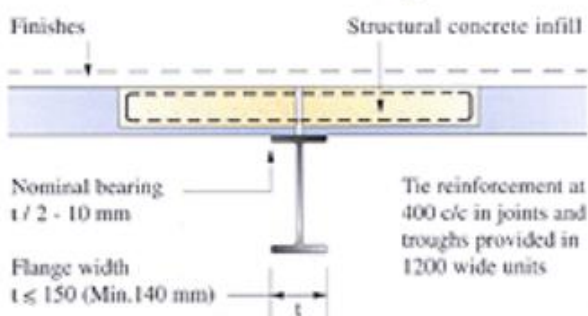
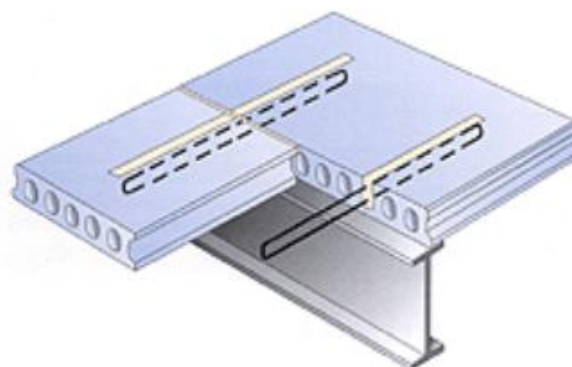

### END SLOTS IN UNITS

Slots may be provided in slab ends for the purpose of tying into the structure for nominal continuity

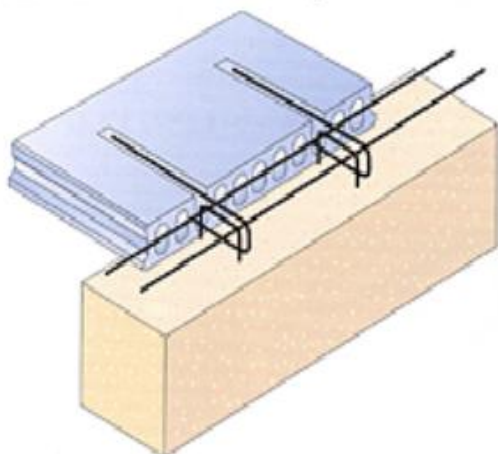

### TRIMMING OPENINGS

M.S. Trimmer,  
Fire protection, where necessary by General Contractor

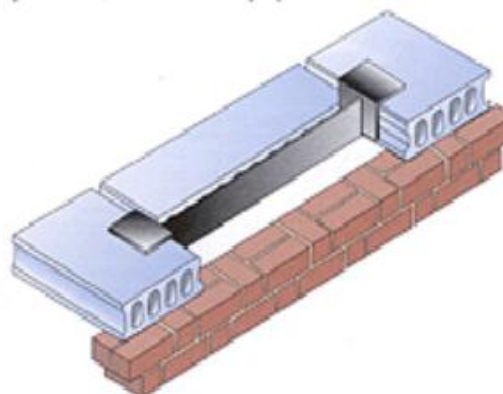



Picture 4.2.7: Union slab with precast beam  
Source: <http://www.bison.co.uk/>



Picture 4.2.8: Trimmer beam to carry holes in concrete.  
Source: <http://www.hollowcore.com.au>

### Advantages:

- Good distribution of loads and transverse breakdown.
- Short execution time.
- Allows saving formwork, rebar and concrete work.
- Safer work to be able to walk across the surface of the plates.
- High resistance to fire. Up to 120 minutes with standard coatings.
- Supports large spans with little sagging.
- No need to use compression layer work.
- Better sound insulation than traditional forged.
- Need for labor less than traditional forged.



#### 4.2.2 PRE-SLAB

It can be defined as a sheet of corrugated steel reinforced concrete that contribute to the mechanical performance of the floor, as well as of lattice-work that form the frame of beams and slabs of polystyrene foam of density 20 kg / m<sup>2</sup>.



Picture 4.2.9: Pre-slab expanded polystyrene in the alveoli.  
Source: <http://www.hermosl.net>

Attached to the concrete poured on site, with own characteristics of both technical and technological, will allow the concrete after setting, consider the whole as monolithic.

#### **Features:**

- Once installed, it will serve as permanent formwork, thus avoiding the siding of the work.
- It allows to make slab supported floors with 2 structural shoring and rarely with 3.
- It has a good resistance which gives us a total security while traveling over it.
- Its surface is completely flat and smooth allowing us to have a suitable finish without false ceiling.
- It is easy to handle.
- It fits perfectly as a series for inter-axis from 1.20 to 7.50 m.
- Can be reinforced or prestressed.

- The underside is smooth to let light or for painting it directly. The topside is very rough to get a better grip with the top slab concrete, poured on site and ensure the two concrete monoliths.
- In order to adapt to all kinds of works, the side seams have a chamfer pre-slab well studied to let them view.
- The monolith of the top slab of the slab ensures cross-sharing of course loads and can also generally absorb the architectural bracing or upwind of the building.
- The thickness can vary, the armor coating, handling, transportation and sometimes by the limitation of armor between joists.<sup>9</sup>
- Geometric conditions to be met:
  1. The most typical song is 26 cm, with a weight equal to the classical beams and slabs which are replaced.
  2. It is usually manufactured with widths of 1.2m and 0.6m lengths up to 7m with 22 freestanding +5 singing, although there are cases in which light can reach higher. In the case of precast slabs with lattice, it is recommended that the clear distance between them does not exceed 20 times the thickness of the slab and the distances between trusses extreme lateral edges do not exceed 30 cm.

### **Applications:**

The fields of application of such slabs are similar to those of the alveolar plate, resting on walls in terraced houses, supported by beams formwork panels residential high-way, on the structure of beams and columns and precast parking shopping centers.



*Prcture 4.2.10: Height housing*

### **Work placement:**

The prefabricated elements are placed in the truck stacked on each other. They will be downloaded in its loading position with the lifting elements described therein. The pre-slab hold it every four points at 1/3 of the light of the pre-slab, the hitch is made at the nearest node of the lattice. The maximum angle between the sling and the vertical is 30 °.



*Picture 4.2.11: Mount pre-slab*  
Source: <http://oscalsl.blogspot.com>

The installation of a floor-based precast slabs mainly consists of three stages:

1) In this first stage is positioned in place the pre-slab placement. The pre-slabs must joists each distance as listed in the schedule of use of each manufacturer.

2) Provision of reinforcement: In this step are placed all the reinforcements needed for the operation of the floor: reinforcement connection between pre-slab and beam concrete, negative reinforcement, distribution-layer mesh compression, reinforcement of concrete beams , etc.

3) Concreting of the slab. At this stage, the floor is concreted: gaps between slabs of expanded polystyrene are concrete filled, as well as 5 cm. layer compression. In the same way as we made in any concrete structure it is needed to vibrate concrete poured.



Picture 4.2.12: Mounting on steel beams pre-slab  
Source: Own picture

### Advantages:

- Improves camber, making it just does not exist.
- Allows the use of tower cranes normal work.
- Improves thermal insulation thanks to polystyrene.
- Offers a good deal of lateral loads and delivers a lower weight to the foundations and walls.
- 5 hours can withstand fire without reinforcement of any kind.
- Give space and light thanks to the lights that can be achieved.

As we have proof, advantages are quite similar to those of the alveolar slab, but the pre-slab offers greater ease when it comes to rest on the girder and concrete to work together. In the case of the alveolar slab, it is necessary to chop the topface in the area of support for drilling the alveoli and allow to penetrate the concrete while the pre-slab, having porexpan at the top it will not be necessary this operation.



#### 4.2.3 FLOORS WITH SEMI-RESISTANT ELEMENTS

##### Unidirectional framework by semi-resistant prestressed tie-beam

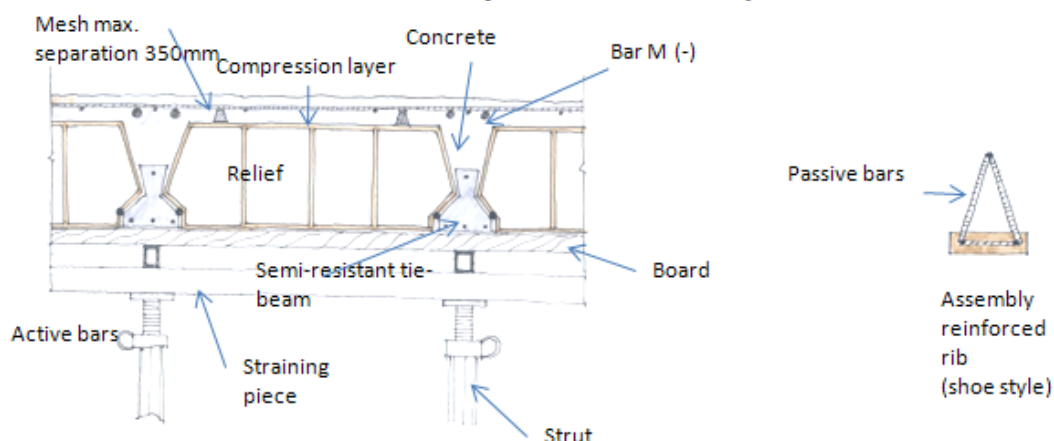

##### Unidirectional framework by resistant prestressed tie-beam

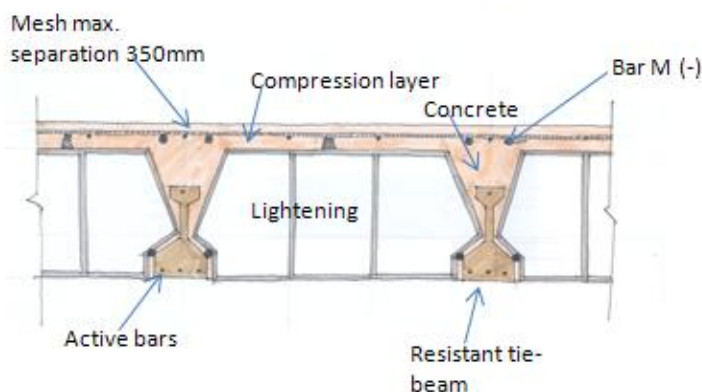

##### Unidirectional in situ reinforced tie-beam framework

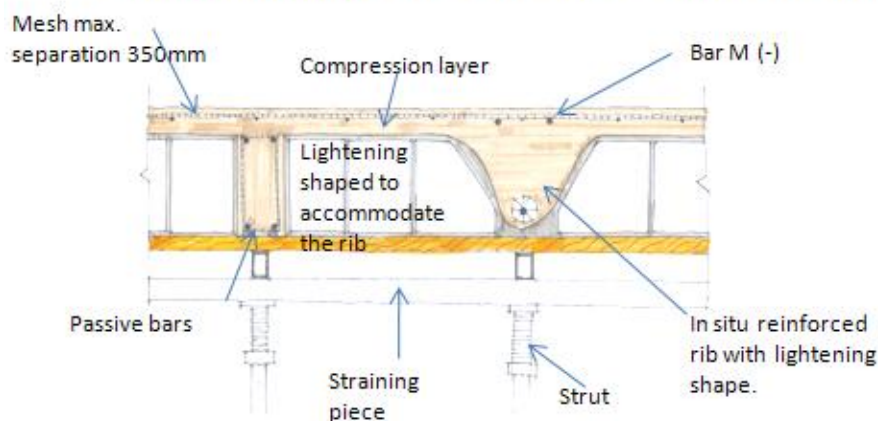

#### 4.2.4 METAL FRAMEWORK (composite slabs)

It can be defined as a sheet of corrugated steel reinforced concrete that contribute to the mechanical performance of the floor, and lattice that form the frame of beams and slabs of polystyrene foam of density 20 kg / m<sup>2</sup>.

##### **Features:**

The main feature of the plate as base and floor slab formwork is in its "decking" character. The technique of the floor decking is to work together to concrete ribbed steel plate that serves as support, working the latter in tension and concrete in compression.

- The use of a plate of steel decking with a concrete finish above it, dates from 1938 in the United States.
- Ribbed plates are used as formwork fixed steel capable of withstanding the poured concrete, reinforcement and executive loads.
- Once hardened the concrete, steel plates are combined structurally and act as tensile reinforcement in the slab finish.
- The shaped steel plate serves as bear the cost of dumping during the formwork (weight of the metal and concrete) and assembly.
- It also replaces the reinforcement for positive moments that occur in the slab.
- It can be placed on metal or concrete belts, or walls.
- Geometric conditions to be met:
  1. For containing the concrete in the slab edge, we will put a 1.20 mm thick profile steel slab for heights of 100 to 150 mm, and 2 mm id it is bigger.
  2. The width of the sheet is usually about 82 cm and the length is variable depending on the needs, seeing only limited by their ability to transport and handling on site (about 12-14m)
  3. The compression layer is usually 3-5cm ensuring a continuous slab without cracks.
  4. The metal frames used in metal slabs are essentially profiles I, L and sheets.

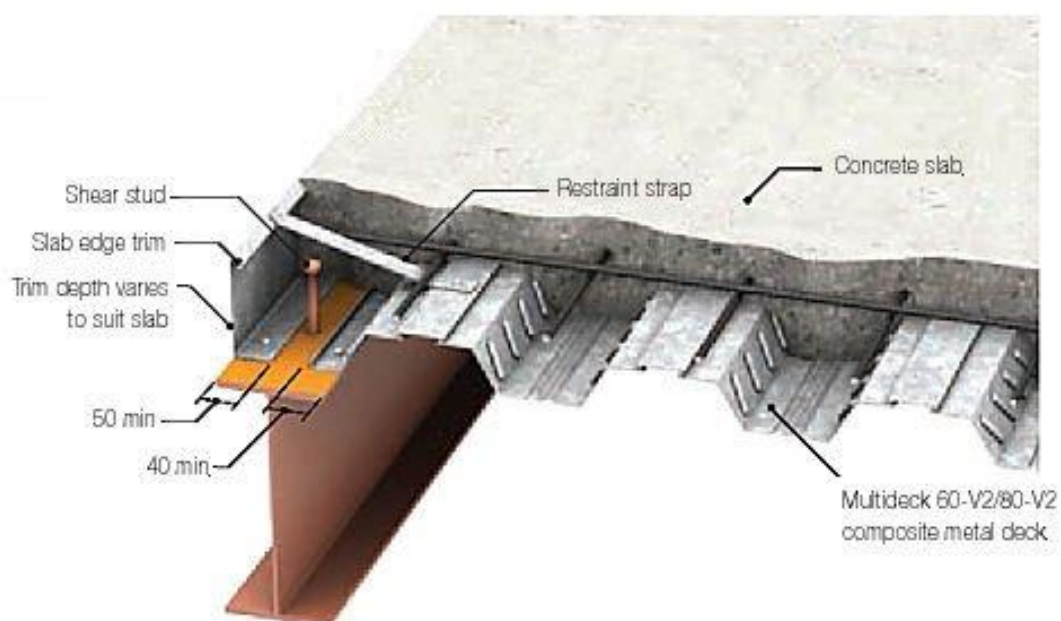

### **Applications:**

- Modular construction: hospitals, schools, office buildings, residential construction repetitive.
- Civil works: pedestrian walkways and small bridges, tanks and canals covering ...
- Individual buildings and high rise to give constructive solution to the requirements they may have.



Picture 4.2.13: Gallery exhibitions.

Source: <http://www.soloarquitectura.com>

### Placed on site:

The construction of such slabs, being self-resistant tie-beams, it follows the steps in the construction of the general metal.

The platform serves as a work platform for workers who put metal beams and especially for welders.

This type of floor is expensive, but it is a solution of special interest in the case where high loads are required with a small edge.

The most commonly used profile is the I, but for edges, cantilever tip ... we use the profile ] .

On many occasions the tie-beams interaxis is greater than is used in concrete floors, surpassing even 1 meter. This requires special considerations top slab thickness and even the transverse reinforcement.



Picture 4.2.14: Types of sheet metal.  
Source: <http://www.ferrosalonso.com>



Picture 4.2.15: connectors that attach the plate to be forged  
Source: <http://www.ferrosalonso.com>



Picture 4.2.16: mesh shrinkage and distribution. Compression layer.  
Source: <http://www.soloarquitectura.com>

Picture 4.2.17: Industrial Building.  
Source: <http://www.soloarquitectura.com>



### **Advantages:**

The most significant advantages are:

- Rapid assembly.
- Allow large spans and loads with a small section.
- It is not taking into account heavy elements that support the load.
- It is not necessary to shore, except for heavily loaded floors that receive a central prop.
- Positive reinforcement is not needed.
- It is nor necessary to remove the formwork plan, due to the corrugated sheet makes the role of formwork lost.

However there are some disadvantages:

- High cost.
- Thermal and acoustic misbehavior, mainly through vibrations transmitted to the entire structure.
- Misbehavior before the fire, owing to be protected by fire retardants.
- Danger of oxidation, requiring the paintings antioxidant protection.

## 4.3 IN SITU FRAMEWORK

---

### 4.3.1 SOLID SLAB

The plate forged solid concrete built on site are now little used in Spain, where they are used mostly unidirectional slabs and precast concrete poured on site or reticulated floors based on lightened plates. The reasons for this are primarily economic and sociological. On the one hand, the cost of materials has had a major impact on the total cost of the slab, so that tended to lightweight solutions (either unidirectional or bidirectional) to allow a reduction in the volume of the floor and your weight. In addition, the inertia to change existing in the world of construction means that, in general, continue to use solutions that do not require modification of the known systems of operators with which the yields achieved in the implementation are apparently satisfactory.

However, there are several reasons why it has begun a shift towards solutions based on solid bidirectional slabs, supported on brackets. These include the increased cost of labor, the ease of construction, durability of the floor and reduce occupational hazards.

#### Features:

- The solid plate floors are easy to build, since lightening items are removed, either filler blocks, blocks and caissons recoverable. In the absence of nerves, forming operations, formwork, rebar, concrete vibrated and, in general, the execution control are less expensive and can be reduced execution times.
- The existence of less contact surface with the environment, as well as the elimination of reduced thickness (nerve compression layer), greatly reduces the risks of attack on the durability of the slab.
- The existence of a flat bottom formwork and complete work provides a comfortable platform, which together with the absence of manipulation of parts that can break or fall as arches or beams, reduces the risk of accident.

Do not forget that, for security reasons, it is mandatory to have the full continuous shuttering the flat for the implementation of the floors of any type, so the formwork in itself is not a differentiating factor in most solutions.

Finally, structural features are comparable to those of a stone lighter, as though they have more weight to the same song, its rigidity is higher in order to reduce vibrations arrows, as well as its monolithic and acoustic insulation provided , so in some cases the song may be less than those.



Its ductility is higher than the unidirectional slabs with flat beams, being therefore suitable solutions for seismic zones (subject to security check puncture under vertical acceleration) and that can tap the reserve strength plastic that gives the hiperstatism in both directions.



*Picture 4.3.1: Solid navy plate  
Source: Own picture*

### **Applications:**

The use of the plates is given in floors of buildings, walls of water tanks and bridge decks.

Within the different types of plates, are of particular interest the solid plate on isolated supports, that is directly supported by columns, with or without capital, the use of buildings results insignificant benefits.

### **Advantages:**

- Allow proper behavior of the structure under horizontal actions, because due to its high rigidity in the plane, standardize the horizontal displacement (the only one-way slabs have rigidity in the direction of reinforcement) and have ductility in both directions. As a result there is no problem for use in earthquake zones or major wind action.
- Location flexibility is achieved joints and horizontal distribution of services (unidirectional formwork presents only services in the direction perpendicular to the work).
- It is much easier placement of reinforcement and supervision, which means less labor cost and execution control.
- It is much easier placement and vibrating of concrete.

- It allows the possibility of industrializing largely construction processes, reducing the time and budget variances.
- They have less overall depth. Also, beams or ribs are not needed (protruding from the edge of the plate) that decrease the clearance and / or impair the aesthetics.
- The architectural finish can be applied directly to the underside of the plate. In some cases such as local parks or commercial or industrial use can be left lower surface with concrete, reducing costs and implementation times.
- They allow good sound insulation. Ensure thermal insulation is guarantee, even more than the ribbed plates.

### 4.3.2 WAFFLE SLAB

#### Features:

The waffle slab belongs to the family of reinforced concrete slabs, no uniform, lightweight and reinforced in two orthogonal directions forming a ribbed plate.

In the reticular and about the pillars of the blocks is dispensed with lightening and the plate becomes solid ribs disappearing as such. This defines the abacus, which is the area of a plate around a support or capital that is highlighted, or if it is a lightweight plate is solid with or without shoulder. Solid plates may not exist, and if present, may be accompanied by capital. And lightened plates (grid), their existence is mandatory and may be accompanied or not of capital.

- To resist the punching head is usually widen the pillar is the capital.
- The structure thus formed admits that bends can be broken down and analyzed according to two e-armed.
- Form with supporting a structural assembly capable of withstanding the vertical spread and timely actions very well, and the horizontal reasonably well but in a much smaller extent than the first.
- The basic parameters that define the characteristics of the waffle slab are:
  - Total depth of the plate.
  - Height coffers lightening or lightening blocks.
  - Ribs separation
  - Basic thickness of the ribs, although in the reticular recoverable have a core of variable thickness truncated.
  - Thickness of the layer compression.

The waffle slabs are only a particular case taken from the world of plates that are part of the slab being the more general case of this family. So how to tackle your project, design and construction is



similar in both cases taking into account its nuances.

- These are armed two directions, usually orthogonal (grid).
- Basic Parameters of a waffle slab:
  - Separation or nerves inter-axis wheelbase ( $e = 80$  cm).
  - Thickness of the ribs ( $b = 10$  cm).
  - Total depth of the plate ( $H = h + 3$ ).
  - Lightening block height ( $h$ )
  - Thickness of the compression plate ( $c = 3$  cm).



*Picture 4.3.2.1: Bottom waffle slab where the caissons are observed and the abacus on the pillar.  
Source: <http://www.celsa.com>*

### **Applications:**

The site has forged strong tradition of using the prefabricated, since it comes directly from the first floors used in beams and slabs. The solid slabs and lighter, will always be a reasonable solution for any type of work, offering more facilities the more difficult is the geometry or the greater the number of

plants. So we can reach large lights in all types of buildings, everything and can not offer a placement as quickly as prefabricated and industrialized.

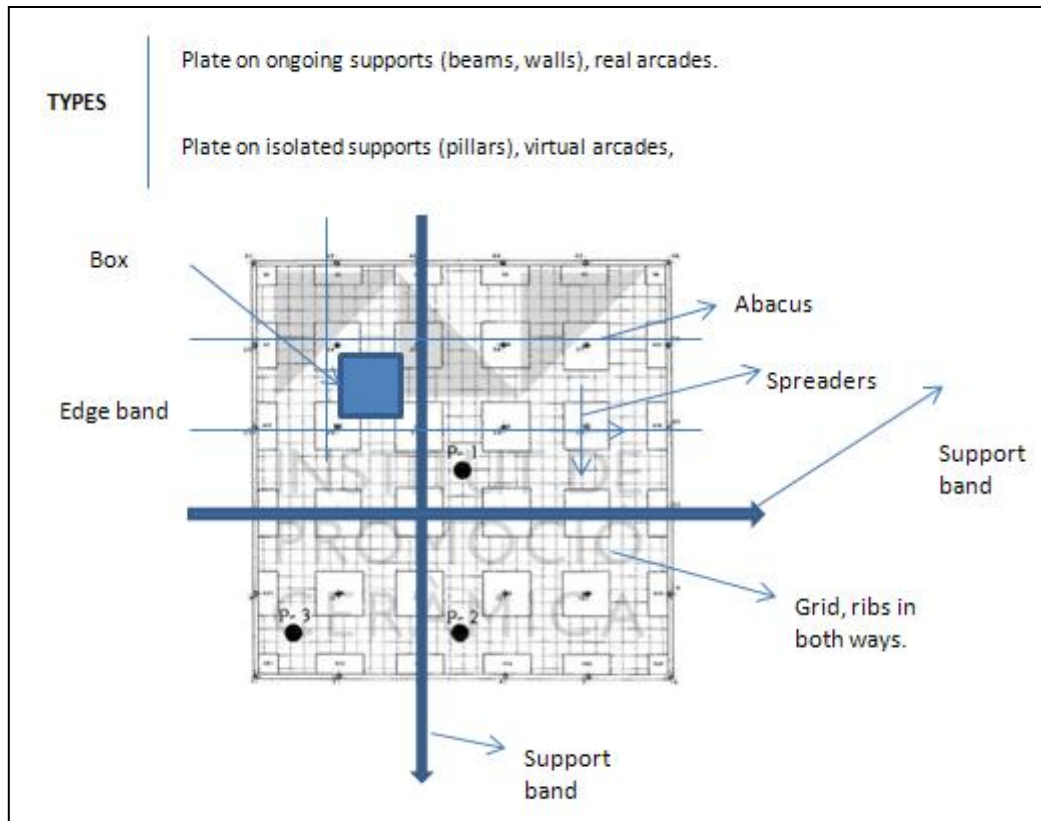

### Advantages:

The biggest difference may exist between reticule and solid slabs is that the first ones have a bidirectional behavior and the second multi-directional behavior.

This difference makes the path of the loads to the supports in the case of the slab more direct and therefore better. In addition, the slab, having an infinite number of nerves, provides greater hyperstaticity.

We can order the three basic types of floor in order of effectiveness (better burden-sharing) and security (degree of hyperstaticity).

1. Slab is the solution that works best. Is the largest to absorb structural irregularities in the plant, because due to their higher loads hyperstaticity manage to find relatively simple ways to the pillars. Therefore allows plant designs that do not support other types properly.

2. Reticular plate: Its operation is similar to above but to a lesser extent, so is also limited in its benefits.

3. The unidirectional slabs, as in the case of prefabricated panels which we have quoted above, have smaller benefits and require resistant structural design ordered. However, in these conditions provides a good performance. Also lighter than the previous ones and its implementation is not necessarily shuttering the plant.

The slabs in situ, despite their greater weight, greater voice and use of formwork, provide greater freedom and flexibility for changes in the project and singularities. Its bigger weight and its compact providing give a good heat and acoustics resistance.



Picture 4.3.2.2: Installation of caissons and girders  
Source: <http://www.celsa.com>

Picture 4.3.2.3: Formwork view  
Source: <http://www.celsa.com>

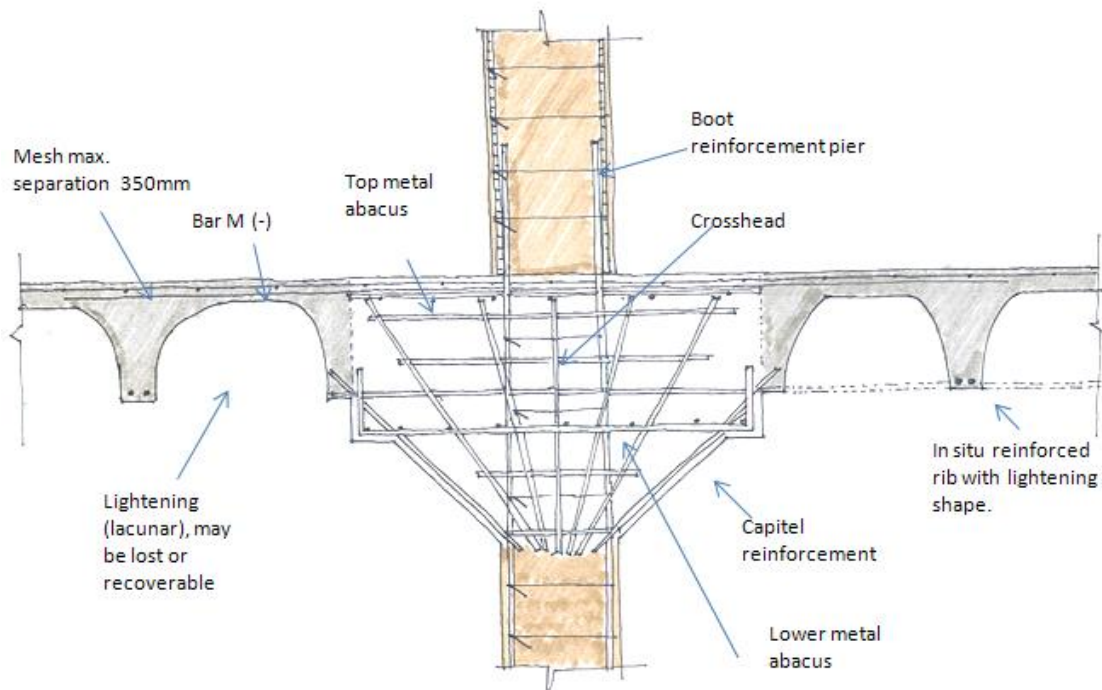

# Chapter 5

## COMPARATIVE STUDY

### 5.1 DIFFERENCES AND SIMILARITIES

---

After studying the different types of systems of slab construction, in this chapter, we will try to develop the differences between the structural elements of both countries.

Among the few existent differences we highlight an important classification systems. In Spain we classify in Unidirectional and Bidirectional, classifying the slabs according to the form of transmission charges. In Poland this type of classification does not exist. The vast majority of the floors are made unidirectional and for the alleviation of frameworks we used materials as expanded polystyrene.

#### WOODEN FRAMEWORKS:

For various reasons it is rare to find in Spain, saving the special case of the laminated beams, buildings that have solutions in wood construction. In contrast to many neighboring countries (in this case Poland) where its use is commonplace and everyday life, in Spain a mixture of lack of cultural tradition in its use, lack of confidence in their capabilities, and ignorance of its material qualities make even today something strange use of wood in architecture. Over 40 years of socialist construction in Poland, have been forgotten and neglected the use of wooden. During this period they dominated over reinforced concrete slabs. But in the last decade have begun to return to favour. Increased availability of wooden construction, with many mills, there are new measures to impregnate wood.

## SEMI-RESISTANT FLOORS WITH ELEMENTS - ACKERMAN, CERAM, Cerit, FERT ...

These types of floors are the following differences:

<b>SEMI-RESISTANT FLOORS WITH ELEMENTS (SPAIN)</b>	<b>ACKERMAN, CERAM, Cerit, FERT ... (POLAND)</b>
It has a top slab of concrete (compression layer) into a work of thicknesses 5, 8, 10 and 15 cm depending on the thickness of the slab.	Thickness of top slab concrete 3 or 4 cm, depending on the value and type of variable load.
Embedded in the top slab of concrete is a welded mesh reinforcement that serves as a distribution and to avoid shrinkage and thus cracking the concrete.	In either type of floor is named using this mesh.
The most widely used type of beam are resistant prestressed.	The most widely used type of joist semi-resistant is reinforcement.
Spacing between joists: the distance is between 60 and 75cm.	The separation is usually 31, 40 cm ...

Due to the large number of companies that trade with the resistive elements that make this type of floor, we can find a lot of variety of dimensions that support the design of the floor.

In both countries used for placing the formation of a perimeter ring and tie serves to support this type of floor.

### ALVEOLAR SLAB - BEAM PLATE

The use of these two types of stone, is very common in both countries, being also their works and characteristics quite similar, due to the large number of commercial companies that manufacture these tiles. Its size can vary greatly due to the large range of lengths that we offer and may exceed 30 meters.

The most notable similarities, because they are the main reason for using this type of slab are:

- Easy maneuverability, simplicity and speed of execution. What causes it to reduce delays and costs by not requiring repair kit.
- The roof can be used immediately after installation and can continue working.
- High resistance to fire.

### **PRE-SLAB - filigran**

Among these systems no differences in the composition or methods of installation. Applications typically take place in both countries in structures prefabricated girders and pillars parking and shopping.

The filler material is used and gives lightness to the slab is expanded polystyrene.

### **FORGED METAL**

This system is known in both countries, but its application is higher in Spain (construction of industrial buildings for large areas) causing no great confidence in the way of working in Poland and that the leaks that occur through concrete rainwater are retained in the sheet metal decking, causing malfunction set between the two materials and the deterioration of the plate.

In conclusion of the study, it appears that there is great similarity between the construction of floor systems, despite the distance separating the two countries and their climatic differences.

## Chapter 6

### ACKNOWLEDGEMENTS

At this section, there are many sensations and feelings that go through my head. Also there are many that I must give thanks to all who have contributed to my project or have shown me their support.

The opportunity has given me can do my project in Poland, has been an unforgettable experience. During these months I have met a new culture, a different way of life and many people that I will remember forever.

I want to thank my tutor Dr Rafal Poland Krzywon that has guided me in this project and the University Politechnica Slaska.

Of course, many thanks to my parents who supported me from the distance and allowed me to experience this adventure and especially Samuel for his tireless support and patience throughout this time.

And thanks also to:

- Luis Santafosta for teaching me and guiding me during the race.
- My colleagues over the years that have been of great importance at this stage of my life.

# Chapter 7

## REFERENCES

- **POKORSKA-OZÓG EWA** (2009), *Secesyjne elementy wystroju gliwickich kamienic*.
- **KLAJMON B.**, Górnośląskie kamienice mieszczańskie. Katowicka kamienica mieszczańska 1840-1918, Katowice 1997
- **SZOPA R.** (2002), Kamienice Chorzowa, Muzeum w Chorzowie.
- **BARBARA KOZŁOWSKA**, Studium historyczno-konserwatorskie miasta Gliwice, część II, tom III, Śródmieście. (Study of history and preservation of Gliwice, Part II, Volume III, City center).
- **CTE**, Código Técnico de la Edificación
- **REGALADO TESORO, F.**, 1999, “Los forjados de los edificios: presente, pasado y futuro”,
- **REGALADO TESORO, F.**, 2003, “Los forjados reticulares: diseño, análisis, construcción y patología”
- **RODRÍGUEZ MARTÍN, L.F.**, 2005, “Forjados”
- **NOTES POLITECNICA DE VALENCIA**, Subject Construcción II, (ETSGE)
- **BEDNARSKI ADAM**, 2009 Zarys modernistycznej architektury Gliwic (1919-1939), wydawnictwo Politechniki Śląskiej
- **WEBS**

<http://www.mapofpoland.net>

<http://www.zgapa.pl>

<http://www.staypoland.com>

<http://www.techbud.com>

<http://www.polsl.pl>

<http://www.muratorplus.pl>

<http://stropy.webpark.pl>

<http://dolcan.com>

<http://www.previerval.com>

<http://www.celsa.com>

<http://esp.prefabricatspujol.com>

<http://www.muratorplus.pl>