

# 5th CARPE Conference

## HORIZON EUROPE AND BEYOND



UNIVERSITAT  
POLITÈCNICA  
DE VALÈNCIA



VALENCIA (Spain)  
23-25 OCTOBER 2019

### PROCEEDINGS



 **TURKU AMK**  
TURKU UNIVERSITY OF  
APPLIED SCIENCES



UNIVERSITY of  
**DEBRECEN**

 **HAW**  
**HAMBURG**

*Congress UPV*

**5th CARPE Conference. HORIZON EUROPE AND BEYOND**

The contents of this publication have been evaluated by the Scientific Committee which it relates and the procedure set out

<http://ocs.editorial.upv.es/index.php/CARPE/CARPE2019/about/editorialPolicies>

© **Scientific Editors**

Javier Orozco Messana

Juan Miguel Martínez Rubio

Education: José Benlloch, UPV Institute of Industrial Control Systems and Computing

Sustainability: Elena de la Poza, UPV Economic Engineering Research Centre

Innovation: Patricio Montesinos, Head of Lifelong Learning Centre

Health: Mariano Alcañiz, Head of I3B Institute for Research and Innovation in Bioengineering

© **Publisher**

Editorial Universitat Politècnica de València, 2019

[www.lalibreria.upv.es](http://www.lalibreria.upv.es) / Ref.: 6523\_01\_01\_01

ISBN: 978-84-9048-789-1 (print version)

Print on-demand

DOI: <http://dx.doi.org/10.4995/CARPE2019.2019.10582>



**5th CARPE Conference. HORIZON EUROPE AND BEYOND**

This book is licensed under a Creative Commons Attribution-NonCommercial-NoDerivatives-4.0 Int. Licensed

Editorial Universitat Politècnica de Valencia

Based on a work in <http://ocs.editorial.upv.es/index.php/CARPE/CARPE2019>

## INTRODUCTION

This electronic conference proceedings incorporates the papers submitted by researchers from the CARPE network to its fifth networking meeting. CARPE is a European strategic network aiming at joint applied research and development as well as pedagogical development in the fields of professional education. The current members of the network are HU University of Applied Sciences Utrecht, Turku University of Applied Sciences, Polytechnic University of Valencia and Hamburg University of Applied Sciences. The biennial networking event was organized by Universitat Politecnica de Valencia on 23-25 October 2019.

The scientific contributions develop proposals for collaborative projects, as well as resumes of the research interests for CARPE group. The purpose of the presentations was to align existing research possibilities within the network in order to develop proposals for EU projects on the different calls and available programs. All contributions were structured according to the main pillars common to all partners:

- Education.
- Sustainability.
- Innovation.
- Health.

The motto of the conference was EU Education, sustainability, innovation, societal challenges and entrepreneurship, digital transformation for health care and well-being, and the main focus was to develop the EU mandate on applied research for the future of Europe.

The CARPE network has been developing for more than ten years the now acclaimed EU policy on getting Research results to the society from the organizing Committee we expect that our network and collective research efforts by the partners will bring this objective into a reality.

Valencia October 2019.

Juan Miguel Martinez-Rubio  
Javier Orozco-Messana

# SCIENTIFIC COMMITTEE CARPE CONFERENCE

## Education:

Track director: Jose Vicente Benlloch-Dualde ([jbenlloc@disca.upv.es](mailto:jbenlloc@disca.upv.es))  
Harri Lappalainen ([harri.lappalainen@turkuamk.fi](mailto:harri.lappalainen@turkuamk.fi))  
Minna Scheinin ([minna.scheinin@turkuamk.fi](mailto:minna.scheinin@turkuamk.fi))  
Zita Schillmöller ([Zita.schillmoeller@haw-hamburg.de](mailto:Zita.schillmoeller@haw-hamburg.de))  
Thomas Dohmen ([thomas.dohmen@hu.nl](mailto:thomas.dohmen@hu.nl))  
Elek Bartha ([bartha.elek@unideb.hu](mailto:bartha.elek@unideb.hu))

## Sustainability:

Track director: Elena de la Poza-Plaza ([elpopla@esp.upv.es](mailto:elpopla@esp.upv.es))  
Juha Kääriä ([juha.kaaria@turkuamk.fi](mailto:juha.kaaria@turkuamk.fi))  
Jari Hietaranta ([jari.hietaranta@turkuamk.fi](mailto:jari.hietaranta@turkuamk.fi))  
Water Leal Filho ([walter.leal@haw-hamburg.de](mailto:walter.leal@haw-hamburg.de))  
Mieke Oostra ([mieke.oostra@hu.nl](mailto:mieke.oostra@hu.nl))  
Zoltan Szalaky ([szakaly.zoltan@econ.unideb.hu](mailto:szakaly.zoltan@econ.unideb.hu))  
Dr. Balogh Péter ([balogh.peter@econ.unideb.hu](mailto:balogh.peter@econ.unideb.hu))

## Innovation:

Track director: Patricio Montesinos-Sanchis ([pmontesi@cfp.upv.es](mailto:pmontesi@cfp.upv.es))  
Liisa Kairisto-Mertanen ([liisa.kairisto-mertanen@turkuamk.fi](mailto:liisa.kairisto-mertanen@turkuamk.fi))  
Elina Uitamö ([elina.uitamo@turkuamk.fi](mailto:elina.uitamo@turkuamk.fi))  
Rüdiger Weißbach ([ruediger.weissbach@haw-hamburg.de](mailto:ruediger.weissbach@haw-hamburg.de))  
Christine van Donselaar ([christine.vandonselaar@hu.nl](mailto:christine.vandonselaar@hu.nl))  
Menno Soentken ([menno.soentken@hu.nl](mailto:menno.soentken@hu.nl))  
Peter Popovics ([popovics.peter@econ.unideb.hu](mailto:popovics.peter@econ.unideb.hu))

## Health:

Track director: Mariano Alcañiz-Raya ([malcaniz@i3b.upv.es](mailto:malcaniz@i3b.upv.es))  
Elina Kontio ([elina.kontio@turkuamk.fi](mailto:elina.kontio@turkuamk.fi))  
Paula Ailio ([paula.aiilio@turkuamk.fi](mailto:paula.aiilio@turkuamk.fi))  
Joachim Westenhöfer ([joachim@westenhoef.de](mailto:joachim@westenhoef.de))  
Saskia te Velde ([saskia.tevelde@hu.nl](mailto:saskia.tevelde@hu.nl))  
Laszlo Csernoch ([csl@edu.unideb.hu](mailto:csl@edu.unideb.hu))



## **Keynote speakers**

### ***Facilitation of Hands-on Learning to Foster Innovation in Universities***

Tapio Koskinen (Head of Technology at Aalto University)

Innovations are increasingly emerging from networks of companies, universities and public sector organisations, and they often also include citizens and customers. According to a recent report published by The European University Association (EUA), universities' role in these networks has become more central than before.

Universities are developing infrastructures in order to better foster innovation dynamics. Such infrastructural investments comprise both investments into state-of-the-art large research facilities as well as physical infrastructures that become hubs for co-creation. Researchers and business innovators are brought together in jointly used spaces for co-creation, research, learning and making.

Chemistry labs have a long history in universities and hands on experimentation has been an important part of engineering and design education. Availability of various equipment for digital fabrication has accelerated the growing popularity of making. Makerspaces, Fab Labs, Design Factories and hackerspaces have been emerging on university campuses during the past decade.

This keynote will provide a brief history of hands on learning art, design, architecture and engineering in higher education. Recent trends in the use of education and research infrastructures will be introduced and their impact on innovation dynamics will be discussed.

### ***Future EU research programmes beyond H2020***

Victoria Reichl (Deputy Director of KoWi)

The key-note speech will focus on the up-coming European framework programme for research and innovation, Horizon Europe (2021-2027).

One year ahead of the first call for proposals, many important elements of Horizon Europe are still under discussion.

In parallel, difficult negotiations for the next EU budget (MFF) are ongoing, overshadowed by the Brexit process.

Aspects that will change and many that will remain the same compared with the current framework programme Horizon 2020 will be highlighted and new features of the programme will be presented.

The speech will conclude with specific suggestions for universities of applied sciences to open up the debate with the audience.

## INDEX

### *EDUCATION*

- “Procedure for the evaluation of transversal competences in lab practices: application to the course on heat transfer at the UPV” by L. Montuori, C. Vargas-Salgado, D. Alfonso-Solar and P. Bastida-Molina, from UPV (Spain) 1
- “Stealing their beer time: turning studying for medical progress tests into a game” by Aletta Smits, Annette Schenk and Lizet van Ewijk, from HU (The Netherlands) 9
- “Capacity building on the field of Life Sciences – potential project idea for CARPE partners” by János Felföldi, from U. Debrecen (Hungary) 17
- “Empowering Youth Employment through European Digital Bootcamps (EDIBO)” by J. E. Luzuriaga, B. Sáiz Mauleón, O. Ampuero-Canellas, L. G. Lemus-Zúñiga, M. A. Mateo Pla, J. V. Benlloch-Dualde, J. González-del-Río and N. Tarazona-Berengue, from UPV (Spain) 21
- “eSGarden: a European initiative to incorporate ICT in schools” by Sara Blanc and J. V. Benlloch-Dualde, from UPV (Spain) 29
- “Theoretical and Empirical Background for a Higher Education Model of Active Community Learning” by Gabriella Pusztai, Zsuzsanna Demeter-Karászi and Tímea Szűc, from U. Debrecen (Hungary) 38
- “Making the change – how did we succeed? Case Innopeda” by Liisa Kairisto-Mertanen and Marjut Putkinen, from TUAS (Finland) 48
- “How to introduce research into university teaching: A training experience in the UPV” by A. Fernández March, E. García Félix, A. García Carbonell, J. V. Benlloch-Dualde, P. Bonet Espinosa and J. Oliver Villarroya, from UPV (Spain) 56
- “Global challenges, local impact” by Erik Mooij, Ilse Schröder, Ed de Jonge and Frank Evers, from HU (The Netherlands) 67
- “Design for All in Architectural Heritage conservation: the technology challenge” by Vicente López-Mateu and Teresa M. Pellicer Armiñana, from UPV (Spain) 73

## 5th CARPE Conference: Horizon Europe and beyond

### ***SUSTAINABILITY***

- “Active Power Filter Shape Class Model Predictive Controller tuning by Multiobjective Optimization” by Carlos Cateriano Yáñez, J. Richter, G. Pangalos, G. Lichtenberg and J. Sanchís Saez; from UPV (Spain) and HAW (Germany) 79
- “Consumer habits and preferences in the renewable energy market” by P. Balogh, A. Bai, K. Pető and Z. Szakály, from U. Debrecen (Hungary) 87
- “Circularity in value chains for building materials” by E-J. Velzing, A. van der Meijden, K. Vreeswijk and R. Vrijhoef, from HU (The Netherlands) 93
- “Monitoring and evaluation of thermal comfort in urban areas: application to Valencia city” by D. Alfonso-Solar, P. Bastida-Molina, L. Montuori and C. Vargas-Salgado, from UPV (Spain) 98
- “Assessing the increase of solar fields in Iberian Peninsula” by P. Bastida-Molina, D. Alfonso-Solar, C. Vargas-Salgado and Lina Montuori, from UPV (Spain) 106
- “Examination of sustainable and health-conscious lifestyle among the Hungarian population along with the results of three research studies” by V. Kiss, N. Balsabudai, M. Soós and Z. Szakály, from U. Debrecen (Hungary) 114
- “Shaping future research agenda on Sustainability research within the CARPE network” by Erlijn Eweg and Martijn Rietbergen, from HU (The Netherlands) 119
- “Supporting an European Up-scaling of Net Zero Energy House renovations” by Rogier Laterveer, from HU (The Netherlands) 124
- “Enhancing cooperation between HEIs and Companies in South East Asia to accelerate sustainable business opportunities” by Martijn Rietbergen and Erlijn Eweg, from HU (The Netherlands) 125
- “Life Cycle Sustainability Analysis for Circular Economy” by Vanesa G. Lo Iacono Ferreira and Juan Ignacio Torregrosa López, from UPV (Spain) 131
- “Currently Known Characteristics of Bat Species Represented in Hamburg in Respect of Wind Turbine” by P. Krapivnitckaia, V. Dominik Kunz and C. Floeter, from HAW (Germany) 138

## 5th CARPE Conference: Horizon Europe and beyond

### **INNOVATION**

- “Use of wireless communication networks in digitalization of factory environments” by T. Rautava, J. Paavola, J. Hallio, J. Kalliovaara and T. Jokela, from TUAS (Finland) 147
- “Implementing the Rights of the Child” by Cees Hoefnagels, Anna van Spanje and Saskia Wijsbroek, from HU (The Netherlands) 154
- “How to scale the societal impact of work-integration social enterprises?” by Leendert de Bell, Linda Drupsteen, from HU (The Netherlands) 159
- “Welcome in my backyard: how having good neighbours can help ending homelessness” by M. Davelaar, L. van Doorn, A. Gruppen and J. Knevel, from HU (The Netherlands) 168
- “Arduino-based prototype to estimate heat stress indices in urban environments” by C. Vargas-Salgado, L. Montuori, P. Bastida-Molina and D. Alfonso-Solar, from UPV (Spain) 173
- “Potential of landfill biogas production for power generation in the Valencian Region (Spain)” by C. Vargas-Salgado, J. Águila-León, C. Chiñas-Palacios and L. Montuori; from UPV (Spain) and UDG (Mexico) 183
- “Fostering innovation at University of Debrecen” by P. Popovics, L. Jutkusz, K. Petó, Z. Szakály and Z. Bács, from U. Debrecen (Hungary) 191
- “Measurement of the black globe temperature to estimate the MRT index using a smaller diameter globe than a standardized one: Experimental analysis” by C. Vargas-Salgado, J. Águila-León, C. Chiñas-Palacios and D. Alfonso-Solar; from UPV (Spain) and UDG (Mexico) 201
- “UNI-HERITAGE. European Postwar Universities Heritage: A Network for Open Regeneration” by Débora Domingo Calabuig and Laura Lizondo Sevilla, from UPV (Spain) 208
- “Measurement of the Teamwork and Networking Competencies in Innovative Contexts” by J.A. Marín García, M. Martínez-Villaescusa and L. Aznar Mas, from UPV (Spain) 216

### **HEALTH**

- “Promoting health and well-being of entrepreneurs with health technology” by Reetta Raitoharju and Katja Heikkinen, from TUAS (Finland) 218

## 5th CARPE Conference: Horizon Europe and beyond

- “European Integrated Care Horizon 2020: increase societal participation; reduce care demands and costs” by R. Ettema, G. Gumze, K. Heikkinen and K. Marshall; from HU (The Netherlands), (Slovenia), TUAS (Finland) and U. Salford (U.Kingdom) 222
- “Research Centre for Healthy and Sustainable Living” by R. Pieters, N. Bleijenberg, K. Jerkovic, C. Krul, C. Veenhof and H. Wittink, from HU (The Netherlands) 226
- “European Integrated Care Horizon 2020: increase societal participation; reduce care demands and costs in Finnish context” by K. Heikkinen, M. Lahti, J. Berg, A. Kiseleva and S. Eloranta, from TUAS (Finland) 228
- “Healthy Neighbourhoods: Health Promotion and Prevention in Urban Neighbourhoods” by Joachim Westenhöfer, Johanna Buchcik and Jana Borutta, from HAW (Germany) 236
- “New approach for resource allocation in digital healthcare 4.0” by Balázs Kocsi, László Pusztai and Istvan Budai, from U. Debrecen (Hungary) 244
- “The Phenomenon and the Characteristics of Precariate in Hungary” by Anita R. Fedor and Renáta J. Erdei, from U. Debrecen (Hungary) 252
- “Virtual Training in Safety and Security – TUAS Visions for Next Generation Learning” by Mika Luimula, Roosa Talvitie and Nina Rantalaiho-Kulo; from TUAS (Finland) and U. Nizwa (Oman) 258

5th CARPE Conference  
HORIZON EUROPE AND BEYOND



UNIVERSITAT  
POLITÈCNICA  
DE VALÈNCIA

VALENCIA (Spain)

23-25<sup>TH</sup> OCTOBER 2019

EDUCATION



UNIVERSITY of  
DEBRECEN



## **Procedure for the evaluation of transversal competences in lab practices: application to the course on heat transfer at the Polytechnic University of Valencia**

**Lina Montuori<sup>1</sup>, Carlos Vargas-Salgado<sup>2</sup>, David Alfonso-Solar<sup>1</sup>, Paula Bastida Molina<sup>2</sup>**

<sup>1</sup>Department of Applied Thermodynamics, Universitat Politècnica de València, Spain,

<sup>2</sup>Department of Electrical Engineering, Universitat Politècnica de València, Spain.

---

### ***Abstract***

*In this paper, a procedure for the systematic evaluation of lab practices based on the development of transversal competences is presented. This procedure includes the design and completion of specific rubrics (complemented with a personal interview at the end of the session) for each of the experiments carried out during the practice, considering both individual and group educational sides. So, aspects related to the student's behavior when working in-group (and the specific contribution of each student to the group), but also related to the individual performance, attitude, abilities and knowledge which the student should have previously acquired during the theoretical classes are considered.*

*A practical application of the developed method to the practices related to the course on Heat Transfer at the Polytechnic University of Valencia is presented, where some results are also summarized. In such application, the suitability of the proposed procedure is highlighted as a proper mean not just to evaluate, but also to help students developing both specific and transversal competences, which they will use during their whole career and professional life.*

**Keywords:** *Lab practices; rubric; heat transfer; transversal competences; evaluation.*

---

## **1. Introduction**

According to the 2020 Plan, the Vice-rectorate for Studies, Quality and Accreditation of the Polytechnic University of Valencia, Spain (UPV) is supporting the Transversal Competences project since 2012. The result of this process led to the definition thirteen TCs, which are worked out with students in all the official degrees taught at the UPV, undergraduate and postgraduate courses (Bonet-Espinosa, Cabredo-Fagrés, Calvet-Sanz, de Andrés-Martínez, & Soto-Pacheco, 2015). These competences represent a significant innovation, which is expected to provide students with an adequate job placement. However, the process for their integration is still under development, since, unlike the specific competences, the transversal ones do not yet appear in the final academic title, so that today there is not an appropriate methodology for their control and evaluation (Montuori, Alcázar-Ortega, Vargas-Salgado, & Bastida-Molina, 2019). In this framework, the methodology proposed in this article may help professors to properly evaluate the skills developed by the students during the lab sessions, based on the aforementioned TCs.

A survey performed in 2018 to students enrolled in courses on Heat Transfer at UPV (Vilariño-Feltrer, et al., 2018) evidenced as lab practices are highly appreciated for the learning process of this matter. However, students also consider that the documentation provided to perform the practices should be further developed so as to improve the learning process associated to those practical sessions.

In line with these evidences, we propose in this article a kind of template that would facilitate the development of the practice, not just for students but also for professors who should evaluate the students' performance. Standard templates are necessary in order to properly organize the whole practice procedure since it is demonstrated as a well-defined protocol helps students to understand how they can expect to be evaluated, by the time it helps them to improve team work development (Delgado & Fonseca-Mora, 2010). Such templates need to be complemented by rubrics, which necessarily include a sort of key factors that would allow evaluating the students' performance based on the development of transversal competences (TCs), such as Team Work, Problem Resolution or Critical Thinking.

The development of rubrics have been discussed by different authors in the past. Thus, a kind of rubrics for the evaluation of final projects and thesis of master can be found in (Martón, Gallardo, Villanueva, & Ordóñez, 2018). On the other hand, rubrics for engineering classes and, more specifically, applied to Heat Transfer courses, have been studied by (Brown, Thiessen, Van Wie, Abdul, & Adesope, 2012). In this article, we will integrate all these partial aspects in a whole process where the lab session process will be considered since the very beginning (before students come to class) to the conclusion once the session is finished.



## 2. Methodology

The methodology here proposed for the evaluation of lab practices is based on a holistic three-phases procedure that we have designed as BDA: Before the performance of the practice; During the practice; and After the lab session. Therefore, this BDA procedure will allow the professor to evaluate the performance of students during the whole process of the practice.

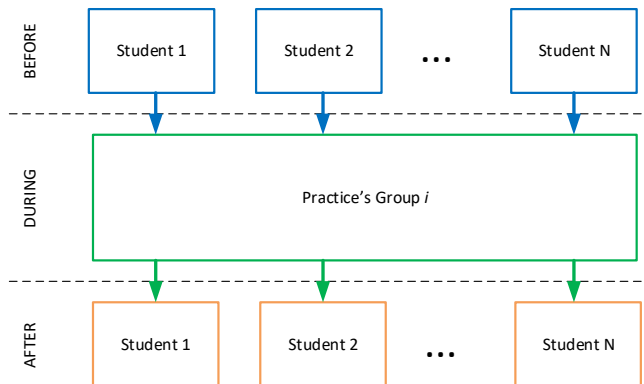

Figure 1. BDA Methodology for the evaluation of lab sessions.

The different phases considered to structure this designed BDA procedure, as depicted in Figure 1, are the following:

- Phase 1: BEFORE the lab session: Practice Preliminary

This first phase means a first approach to the session that students should have taken by reading the documentation provided in advance by the professor. It will be based on a quick questionnaire at the beginning of the lab session that students should answer individually, taking part in the final grade of the session. This activity is essential in order to guarantee that students have read the brochure of the practice before coming to class, so that they are aware about what they will do and what is expected from them.

A five short multiple-choice questionnaire will include some preliminary concepts related to the practice, such as:

- The aim of the practice
- The number and kind of experiments included in the practice
- Some theoretical aspect related to the preparation of the practice
- Some expected result that students should demonstrate during the lab session

The questionnaire can be implemented in the well-known tool Kahoot, whose potential for evaluation purposes at University level has been widely discussed (Sempere Ferre, 2018). The estimated duration for this first phase is 10 minutes approximately.

- Phase 2: DURING the lab session: Practice Development

This phase will be the core of the practical session. During this phase, students will perform the different experiments included in the session. The procedure to be followed by students will be included on a standard template previously designed by the professor. In the template, students will write down the measurements they take during the session. Then, based on such measurements, some calculations will be required in order to demonstrate or validate some concepts previously studied in the theoretical classes. If the professor considers that some ancillary sheet is necessary (for example, when using some application or spreadsheet available at the lab), it will be also indicated in the template. The template will finish with a section of conclusions, where students should write the main results obtained during the session.

Practices will take place in groups, so that the evaluation of this part will be in-group. It means that all the students in the same group will obtain the same grade in this part. However, the professor may take notes regarding the performance of each student during the practice, which will be incorporated and sharpened in during the Phase 3.

- Phase 3: AFTER the lab session: Practice Conclusion

After the completion of the different experiments of the practice, this last part of the evaluation process will consist of a personal interview between the professor and each student. Therefore, the grading of this part will be individual. Interviews will be short (1-2 minutes per student), so that no much additional time is required for the evaluator. In this last phase, students should explain the procedure followed in some of the experiments, which his/her contribution was or what the justification is for some of the obtained results.

### **3. Rubric design and application to the labs on Heat Transfer**

The application of the methodology presented in the previous section is necessarily linked to the design of rubrics for the proper evaluation of the TCs related to each practice. As an example of this, Figure 2 shows the rubric designed for the lab #3 of the course on Heat Transfer, which belongs to the Degree on Energy Engineering taught at the Polytechnic University of Valencia. As shown in the figure, the rubric is applicable for one group

composed of five students as maximum, so that one individual rubric would be necessary for each lab group.

<b>Course:</b>	<b>Heat Transfer</b>		<b>Last name</b>	<b>Name</b>	<b>e-mail</b>
<b>Practice name:</b>	<i>Practice #3</i>	<b>Student 1</b>			
<b>Date:</b>		<b>Student 2</b>			
<b>Starting time:</b>	<i>15:00</i>	<b>Student 3</b>			
<b>Duration:</b>	<i>3 hours</i>	<b>Student 4</b>			
		<b>Student 5</b>			

<b>Phase 1: BEFORE the lab session: Practice Preliminary</b>		
Kahoot grading	Student 1	
	Student 2	
	Student 3	
	Student 4	
	Student 5	

<b>Phase 2: DURING the lab session: Practice Development</b>					
		<i>Measurements accuracy</i>	<i>Calculations accuracy</i>	<i>expression and clarity</i>	<i>Conclusions quality (criticism)</i>
Experiment 1.	<i>Heat exchangers characterization</i>				
Experiment 2.	<i>Verification of the Stefan-Boltzmann law</i>				
Experiment 3.	<i>Emissivity of different surfaces evaluation</i>				
Experiment 4.	<i>Flat solar collector analysis</i>				

<b>Phase 3: AFTER the lab session: Practice Conclusion</b>						
	<i>Individual performance</i>	<i>Role adopted within the group (A/P)</i>	<i>Question Experiment 1</i>	<i>Question Experiment 2</i>	<i>Question Experiment 3</i>	<i>Question Experiment 4</i>
Student 1						
Student 2						
Student 3						
Student 4						
Student 5						

Figure 2. Example of Rubric for the evaluation of the lab #3 on Heat Transfer.

This rubric allows the evaluation of the following Transversal Competences: Application and Practical Thinking; Teamwork and Leadership; Critical Thinking; Effective Communication; and Planning and Time Management. This evaluation will be done taking into account the grade obtained by the student in the different fields included in the rubric, as it will be indicated below.

In the Phase 1 section, the grade obtained by each student in the Kahoot questionnaire will be written down. This grade will take a numeric value, from 0 to 10, directly provided by the Kahoot App.

In the Phase 2 section, four different criteria will be assessed: the accuracy of the measurements obtained by the students during the practice; the accuracy of the calculations

performed, based on the obtained measurements, in order to determine the values requested for each experiment; the written expression and clarity in the elaboration of the report; and finally, the criticism and quality of the conclusions extracted during the development of the practice. These four factors will be evaluated by the professor for each experiment, according to the numeric scale proposed in (Montuori, Alcázar-Ortega, Vargas-Salgado, & Bastida-Molina, 2019), based on the grading used in the Project of Transversal Competences of UPV (Bonet-Espinosa, Cabredo-Fagrés, Calvet-Sanz, de Andrés-Martínez, & Soto-Pacheco, 2015):

**Table 1. Numerical scale assigned to the level of development**

Level of development	Numeric value
A-Excellent	10
B-Good	8
C-Improvable	6
D-Not acceptable	4

While in Phase 2 the assessment is in-group based, in the Phase 3 section each student is individually evaluated. The first two columns refer to the aptitude of each student during the practice, so that this part will be completed according to the notes taken by the professor during the session, according to the behavior of each student within the group. In the first column, the professor will indicate the individual performance of the student, based on the grading scale indicated in Table 1, while in the second column, the professor will indicate whether the student had and active (A) or passive (P) behavior during the session.

Finally, the last four columns correspond to specific questions that each student should answer to the professor related to each of the practices developed during the session. Also in this part, Table 1 will be used for grading purposes.

Once the rubric has been completed, the TCs grading could be done according to the following expression:

$$Grade^{CT_k} = \sum_{i=1}^N RB_i \cdot WF_i \quad (1)$$

Where  $Grade^{CT_k}$  is the grade obtained for each  $k$  Transversal Competence;  $RB_i$  is the grade obtained by the student in each factor of the rubric (from 0 to 10); and  $WF_i$  is the weight assigned to each  $RB_i$  factor, depending on the  $k$  TC that is being evaluated. As an example,

Table 2 shows the values for these coefficients applied to the Transversal Competences worked out during the Practice #3 of the Course on Heat Transfer discussed in this section:

**Table 2. Assignment of values for weighting factors. Example of application**

	Application and Practical Thinking	Teamwork and Leadership	Critical Thinking	Effective Communication	Planning and Time Management
Kahoot	20%	0%	10%	0%	10%
Measurements accuracy	20%	10%	10%	0%	10%
Calculations accuracy	30%	0%	10%	0%	10%
Written expression and clarity	5%	10%	10%	20%	0%
Conclusions quality (criticism)	10%	10%	40%	20%	10%
Individual performance	5%	20%	5%	0%	30%
Role adopted within the group	0%	30%	0%	0%	0%
Questions about experiments (avg)	10%	20%	15%	60%	30%

#### 4. Conclusions

Lab practices are more and more used nowadays for further developing a kind of Transversal Competences of students that they will use during their whole professional life. However, the evaluation of the level of development of such competences is a difficult task, so that professors need support to do it as objectively as possible. In line with this aim, this paper proposes a methodology for the systematic evaluation of lab practices based on Transversal Competences. This method provides also students with templates to be used during the practice. On the other side, professors are provided with a sort of rubrics based on which such Transversal Competences could be assessed in a standard way. This methodology is appropriate for groups of no more than 20 students (3-5 groups per session), that is the usual size for the lab sessions performed at the UPV, where this methodology is being now tested.

## References

- Bonet-Espinosa, P., Cabredo-Fagrés, M., Calvet-Sanz, S., de Andrés-Martínez, D., & Soto-Pacheco, P. (2015). *Proyecto Competencias Transversales UPV*. Valencia, Spain: Universitat Politècnica de València.
- Brown, R., Thiessen, D. B., Van Wie, B. J., Abdul, B., & Adesope, O. O. (2012). Development of a rubric based on Flink's Cognitive Dimensions in a Fluid Mechanics and Heat Transfer Class with potential applications in a variety of engineering classes. *American Society for Engineering Education*, 25.441.1-25.441.21.
- Delgado, M. A., & Fonseca-Mora, M. C. (2010). The use of co-operative work and rubrics to develop competences. *Education for Chemical Engineers*, 5, 33-39.
- Martón, I., Gallardo, S., Villanueva, J. F., & Ordóñez, J. (2018). Diseño de rúbricas para la evaluación de competencias transversales. Aplicación a trabajos Fin de Grado en ingeniería. *IN-RED 2018, 19-20 July*. Valencia, Spain: Universitat Politècnica de València.
- Montuori, L., Alcázar-Ortega, M., Vargas-Salgado, C., & Bastida-Molina, P. (2019). Metodología para formentar el aprendizaje activo de competencias específicas y transversales a través del soporte de softwares ERPs educativos. *IN-RED 2019*. Valencia, 11-12 July 2019: UPV.
- Sempere Ferre, F. (2018). Kahoot como herramienta de autoevaluación en la universidad. *Congreso In-Red 2018* (págs. 250-255). Valencia (Spain), 19-20 July 2018: UPV.
- Solari-Montenegri, G. C., Rivera-Iratchet, M. E., & Abarca-Castillo, M. M. (2016). Rúbricas para la evaluación de la práctica profesional, el internado y el examen de titulación para la carrera de cinesiología según competencias generales y específicas, perfil de egreso y proyecto educativo institucional de la Universidad de Antofagasta. *Fundación Educación Médica FEM*, 19(5), 247-257.
- Vilariño-Feltrer, G., Campillo-Fernández, A. J., Montagud, C., Navarro-Peris, E., Payá-Herrero, J., & Sarabia-Escrivá, E. (2018). Seguimiento del proceso de enseñanza-aprendizaje en la asignatura de transmisión de calor impartida en la Universitat Politècnica de València. *INNODOCT 2018, 14-16 November*. Valencia, Spain: Universitat Politècnica de València.

## Stealing their beer time: turning studying for medical progress tests into a game

Aletta Smits<sup>1</sup>, Annette Schenk<sup>1</sup>, Lizet van Ewijk<sup>1</sup>

<sup>1</sup>HU University of Applied Sciences Utrecht, The Netherlands.

---

### **Abstract**

*Many health education programs use progress tests to evaluate students' progress in learning and to identify possible gaps in the curricula. The tests are typically longitudinal and feedback-oriented. Although many benefits of the progress test have been described in the literature, we argue that the acclaimed facilitation of deeper learning and better retention of knowledge appear questionable. We therefore propose an innovative way of presenting both the test itself and the study process for the test: a real-time-strategy game with in-game challenges, both individual and in teams. In this conceptual paper we provide a brief overview of the benefits and challenges of progress testing and illustrate how gamifying the process of both the assessment and preparatory work taps into many aspects that educators would like to promote in their students' learning outcomes and behavior. We then argue why and how we aim to create a pilot version of a progress test game for medical and allied health students. For the development of this game, six tracks are proposed, that will run mostly in parallel in an iterative process, using design-based research as a framework.*

**Keywords:** *progress tests; gamification; allied health; education.*

---

## **1. Introduction**

Because of the specific requirements of the (allied) health professions, it is imperative that clinicians-to-be have a wide range of knowledge at their fingertips (Dijksterhuis, 2014). To facilitate this, most health education programs employ a type of overall ready-knowledge test: a test that is not connected to one specific course but contains questions on all the facts and figures from all courses in the curriculum, a so-called progress test (Scheele et al., 2004). Although many benefits of the progress test have been described in the literature, we will illustrate in section 2 that the acclaimed facilitation of deeper learning and better retention of knowledge appear questionable. We therefore propose an innovative way of presenting both the test itself and the study process for the test: an online real-time-strategy game with in-game challenges, for both individuals and teams. The game will be embedded in the social context of a program in order to induce an online and offline spectator experience along with the gaming experience. The game should be developed in such a way that the best parts of gaming (as a player and as a spectator) meet the characteristics we would like a student to display in his or her studying behavior. The result should be a student who enjoys spending more time-on-task and more academic learning time (Chickering & Gamson, 1987).

## **2. Progress tests in medical and allied health education**

Progress testing was introduced in the 90s in the Netherlands. Since the tests include items from all relevant disciplines in a curriculum, they are comprehensive and mainly contain multiple choice questions. The tests are administered repeatedly to learners at different stages in their training in order to monitor their progress (Bolhuis, 2005, Dijksterhuis, 2014). In the medical programs in The Netherlands, for example, the progress test is administered between one and four times per year to all students participating in the program (Freeman et al., 2010, Dijksterhuis, 2014). First year students are required to answer the same questions as fourth year students. However, for first year students the threshold for passing the exam is at a lower level.

### **2.1 Progress tests; benefits and challenges**

Progress tests have many benefits from an educators' point of view: they allow for early identification of high achievers, can be used to chart growth of knowledge and clinical skills, possibly remove the need for resits and provide an excellent benchmark to compare performance across programs (Pughet et al. 2015; Freeman et al., 2010). Criticism from within the medical community on the lack of generalisability of the competencies to clinical reasoning in uncertain, realistic contexts, has been addressed by adding open questions to the test. Recently, script concordance testing (Charlin et al., 2000), a scenario-based way of



testing how students apply knowledge in practical situation, has been suggested as the possible next version of the progress test.

Furthermore, progress tests have been argued to have tangible benefits beyond those of simply measuring progress. Coombes et al. (2010) show that progress tests allow for the provision of feedback and therefore should aid learning. Performance can be reviewed by students online, by means of percentages for the different categories within the test. This allows the student to identify areas of weakness they will need to improve on. Further benefits to learning have been proposed by Pugh and Regehr (2016), who suggest that progress tests encourage continuous studying over cramming and therefore foster deep learning strategies and better retention of knowledge.

A study amongst over 6000 Dutch medical students (Dekker & de Feijter, 2007), however, contradicts this assumption. While students appreciate the test because of the sense of progress it provides to them, they widely report that for this test, too, they prepare in cramming sessions (cf. Dijksterhuis, 2014). Furthermore, despite the possibility of receiving feedback, 78% of students report that they do not revise the content of the categories that they scored poorly on. In fact, earlier research shows that just under half of the students does not even log in to view their feedback (Thoben et al., 2006). Therefore, despite the noble intentions of the progress test, its goals are not entirely achieved: educators need to devise a way to make studying for the test more challenging, with more direct feedback, to keep students interested. We propose a game.

### **3. Why we play games and why playing games is a good thing**

#### **3.1 Why we play games**

Video game players report that playing a game can bring them in a state of *immersion* or even *flow* (Brockmyer et al., 2009). *Flow* is described as the joy a person experiences when “a balance between skill and challenge is achieved in the process of performing an intrinsically rewarding activity”. Flow is increased by “the presence of a specific goal and an immediate performance feedback structure” (Moneta & Csikszentmihalyi, 1996). It is suggested that being in a flow enhances learning. It entails a feeling of being in control, being one with the activity, and experiencing time distortions (Coller & Shernoff, 2009).

This is exactly the purpose of our proposal: to turn studying for this test into something that brings students in a state of flow. In order to achieve this, the test should integrate: a balance between skill and challenge; an environment that students feel part of; and an immediate feedback process that helps them learn. That is part I of ‘stealing their beer time’: time they normally spend on ‘going out’ is now spent on doing something else fun, namely studying for their test. Part II of ‘beer time stealing’ will be discussed in section 4.

### **3.2 Why playing games is good**

Games – well-designed games that match with the target group – are not only an engaging activity that can bring its players in a state of flow. It has been shown extensively that the process of becoming good at a game involves many aspects that educators would like to promote in their students' learning outcomes and behavior. In a meta-study, Hainey et al. (2011) found that playing games resulted in better developed long-term and short-term memory, faster perception of a pattern, improved qualitative thinking, and principled decision-making and self-observation. Collier & Shernoff (2009), furthermore, state that learning principles in video games match with constructivist learning theories, active learning, and metacognition. Finally, multiple studies have shown students playing on-topic video games are considerably more engaged, exhibit dramatically better learning outcomes (Collier & Scott, 2009), demonstrate deeper learning, and spend more time on their course than students who study in the classic way (Collier & Shernoff, 2009, Koivisto & Hamari, 2017, Legaki et al., 2019). Specifically for medical education Mayo (2009) reports that a gamified version of teaching immunology can yield a 7% to 40% increase in learner outcomes but warns that such positive effects are only inspired by well-designed games.

We will as a result attempt to change the way the students prepare for their progress test by gamifying their process of studying.

## **4. Turning gaming into a spectator sport**

We propose to take the process one step further: we intend to design not just a good game, but also create an environment in which playing the game can be followed by spectators, both online and offline. This is where we touch upon part II of 'stealing their beer time'.

It has been shown multiple times that being a spectator at a sport, be it a physical sport or a game, improves motor skills (*model learning*, cf. Giudice, Manera, & Keysers, 2009). This is the main reason for attempting to steal students' beer time in this particular way: if we can turn students into spectators of the 'school game', not just the players but also the audience will improve their skills. As a result, they will learn more and/or enjoy playing more (increased time-on-task). Specifically for video games, this is further facilitated by the interactive nature of streaming platforms (Sjöblom & Hamari, 2017).

A second reason for using the spectator element is to create a community around this game. Watching events together supports a feeling of belonging (Sjöblom & Hamari, 2017). This feeling of 'being part of a group', being inside the magic circle (Salen & Zimmerman, 2003), facilitates social integration, an aspect that has repeatedly been shown to be an important factor promoting student success (Tinto, 1987). It is, therefore, imperative to design not just the game, but also the gaming context: public challenges, leader boards, etc.

## 5. Turning an assessment into a game

As we have seen above, the goals of the progress test do not differ much from the strategies students naturally employ when becoming good at a video game. Playing an on-topic video game, that is designed with careful regard for game play, game rules and game world (Aarseth, 2003), will therefore undoubtedly promote the behavior in clinicians-to-be that the progress tests already try to illicit (Mayo, 2009).

While the feedback provided by the progress test is typically not consulted by the average student, the feedback in a video game is more immediate and more to the point: it helps to reach the immediate goal (*continuous immediate feedback*), and will also dole out immediate rewards (*positive reward system* in the form of badges, XPs, accessories, etc.). Rather than losing points for incorrect answers, students gains levels/XP/avatar strength whenever (s)he masters a specific topic, or nails a series of questions on different topics within a specific time frame ('challenge'). Whilst a progress test that is designed for final year students might make a first year student feel little in control, a video game allows the opportunity for adaptive learning (*just in time* information) and the opportunity to process increasingly complex information in increasingly complex contexts (*concurrency chaining*). This last element also connects well with the scenario based testing that medical programs are now experimenting with (Charlin et al., 2000). Finally, multiplayer strategy games, including individual and team challenges, embedded in the social context of the school, with public battles in the cafeteria, etc., strengthen the social surroundings and facilitate team work.

## 6. The six tracks in the development process

The goal of this initiative is therefore to create a pilot version of a progress test game for (allied) health students. Six tracks will be pursued running in parallel in an iterative process, using a design-based research approach (Dolmans & Tigelaar, 2012). The game play and game structure on the one hand, and the game world (various templates for various programs) on the other hand, are the first two important aspects of this project. A third track will be the distribution of knowledge in the game and the way topics are reintroduced or combined with other topics. This entails collecting content and developing algorithms that facilitate adaptive and non-repetitive presentation of content. A fourth aspect involves the embedding of the game in a social context. A fifth track concerns the technical infrastructure, as Mayo (2009) states: educational games often fail because the distribution and accessibility of the game are not up to par, or because the game cannot handle a certain number of players at the same time. Finally, as a sixth track, we intend to implement the pilot game in at least one of the current curricula (Dental Prosthetics and Speech & Language Therapy).

## References

- Aarseth, E. (2003). Playing Research: Methodological approaches to game analysis. Presented at the MelbourneDAC: The 5th International Digital Arts and Culture Conference, Melbourne. Retrieved from: <http://www.bendevane.com/VTA2012/herrstubbz/wp-content/uploads/2012/01/02.GameApproaches2.pdf>.
- Brockmyer, J. H., Fox, C. M., Curtiss, K. A., McBroom, E., Burkhart, K. M., & Pidruzny, J. N. (2009). The development of the Game Engagement Questionnaire: A measure of engagement in video game-playing. *Journal of Experimental Social Psychology*, 45(4), 624–634. doi: 10.1016/j.jesp.2009.02.016.
- Charlin, B., Roy, L., Brailovsky, C., Goulet, F., & van der Vleuten, C. (2000). The Script Concordance Test: A Tool to Assess the Reflective Clinician. *Teaching and Learning in Medicine*, 12(4), 189–195. doi: 10.1207/S15328015TLM1204\_5.
- Cheung, G., & Huang, J. (2011). Starcraft from the stands. *Proceedings of the 2011 Annual Conference on Human Factors in Computing Systems - CHI '11*. doi: 0.1145/1978942.1979053.
- Chickering, A. W. (1987). Seven Principles for Good Practice in Undergraduate Education. *AAHE Bulletin*, Z. F. (Gamson), 2–6. Retrieved from: <https://files.eric.ed.gov/fulltext/ED282491.pdf>.
- Coller, B. D., & Scott, M. J. (2009). Effectiveness of using a video game to teach a course in mechanical engineering. *Computers & Education*, 53, 900–912. doi: 10.1016/j.compedu.2009.05.012.
- Coller, B., & Shernoff, D. J. (2009). Video Game-Based Education in Mechanical Engineering: A Look at Student Engagement. *International Journal of Engineering Education*, 25(2), 308–317. Retrieved from: <http://citeseerx.ist.psu.edu/viewdoc/download?doi=10.1.1.555.9454&rep=rep1&type=pdf>.
- Coombes, L., Ricketts, C., Freeman, A., Stratford, J. (2010). Beyond assessment: feedback for individuals and institutions based on the progress test. *Medical Teacher*, 32(6):486–90. doi: 10.3109/0142159X.2010.485652.
- Dekker, J.A., & de Feijter, J. (2008). De voortgangstoets is geliefd, maar belangen lopen uiteen. *Medisch Contact*, 63(4), 158-159. Retrieved from: <https://www.medischcontact.nl/nieuws/laatste-nieuws/artikel/de-voortgangstoets-is-geliefd-1.htm>
- Dijksterhuis, M.G.K. (2014). De Nederlandse Voortgangstoets Obstetrie en Gynaecologie. *Nederlands tijdschrift voor Obstetrie & Gynaecologie*, 127, 90-94. Retrieved from: [http://www.ntog.nl/dynamic/media/3/documents/NTOG\\_2014\\_2-web.pdf](http://www.ntog.nl/dynamic/media/3/documents/NTOG_2014_2-web.pdf)

- Dolmans, D. H. J. M., & Tigelaar, D. (2012). Building bridges between theory and practice in medical education using a design-based research approach: AMEE Guide No. 60. *Medical Teacher*, 34(1), 1-10. doi: 10.3109/0142159X.2011.595437.
- Duncan, M. C. (1983). The Symbolic Dimensions of Spectator Sport. *Quest*, 35(1), 29–36. doi: 10.800/00336297.1983.10483780.
- Freeman, A. van der Vleuten, C., Nouns, Z., and Ricketts, C. (2010) Progress testing internationally, *Medical Teacher*, 32(6), 451-455. doi: 10.3109/0142159X.2010.485231.
- Giudice, M. D., Manera, V., & Keysers, C. (2009). Programmed to learn? The ontogeny of mirror neurons. *Developmental Science*, 12(2), 350–363. . doi: 10.1111/j.1467-7687.2008.00783.x.
- Hainey, T., Connolly, T., Stansfield, M., & Boyle, E. (2011). The differences in motivations of online game players and offline game players: A combined analysis of three studies at higher education level. *Computers & Education*, 57(4), 2197–2211. doi: 10.1016/j.compedu.2011.06.001.
- Legaki, N.Z., Nannan, X., Hamari, J., Vassilios, A. (2019). Gamification of the future: an experiment on gamifying education of forecasting. In: 2019 52th Hawaii international conference on system sciences (HICSS). IEEE. doi: 10.24251/HICSS.2019.219
- Mayo, M. J. (2009). Video Games: A Route to Large-Scale STEM Education? *Science*, 323(5910), 79–82. doi: 10.1126/science.1166900.
- Moneta, G. B., & Csikszentmihalyi, M. (1996). The Effect of Perceived Challenges and Skills on the Quality of Subjective Experience. *Journal of Personality*, 64(2), 275–310. doi: 10.1111/j.1467-6494.1996.tb00512.x.
- Pugh, D., Touchie, C., Humphrey-Murto, S., Wood, T.J. (2015). The OSCE progress test – measuring clinical skill development over residency training. *Medical Teacher*, 38(2), 168–73. doi: 10.3109/0142159X.2015.1029895.
- Pugh, D. & Regehr, G. (2016). Taking the sting out of assessment: is there a role for progress testing? *Medical Education*, 50, 721–729. doi:10.1111/medu.12985.
- Salen, K & Zimmerman, E. (2003). *Rules of Play: Game Design Fundamentals*. The MIT Press
- Scheele, F., Puyenbroek, J. I., Wolf, B., Schutte, M. F., & Schade, M. I. (2004). Toetsing in de opleiding tot gynaecoloog. *Tijdschrift Voor Medisch Onderwijs*, 23(1), 40–50. doi: 10.1007/BF03056632.
- Sjöblom, M., & Hamari, J. (2017). Why do people watch others play video games? An empirical study on the motivations of Twitch users. *Computers in Human Behavior*, 75, 985–996. doi: 10.1016/j.chb.2016.10.019.

- Smith, T., Obrist, M., & Wright, P. (2013). Live-streaming changes the (video) game. *Proceedings of the 11th European Conference on Interactive TV and Video - EuroITV '13*. doi: 10.1145/2465958.2465971.
- Tinto, V. (1987). *Leaving college: rethinking the cause and cures of student attrition*. Chicago: University of Chicago Press.
- Thoben, A.J.N.M., Leunissen, R.R.M., Jacobs, J.C.G., and Holdrinet, R.S.G. (2006). Het raadplegen van individuele feedback op de voortgangstoets door Nijmeegse studenten geneeskunde, *Tijdschrift voor Medisch Onderwijs* 2006; 25: 125-33. doi: 10.1007/BF03056730.
- Van Goch, M. (2018). Creativity in liberal education before and after study commencement. *4th International Conference on Higher Education Advances (HEAd'18)*, 1475-1483. doi: 10.4995/HEAd18.2018.8228.
- Van Vugt, M., Hogan, R., & Kaiser, R. B. (2008). Leadership, followership, and evolution: Some lessons from the past. *American Psychologist*, 63(3), 182-196. doi: 10.1037/0003-066X.63.3.182. doi: 10.1037/0003-066X.63.3.182.

## Capacity building on the field of Life Sciences

### – fields to articulate project ideas for CARPE partners

János Felföldi<sup>1</sup>

<sup>1</sup> Institute of Applied Informatics and Logistics, Faculty of Economics and Business, University of Debrecen, Hungary

---

#### **Abstract**

*Within the Faculty of Economics and Business of the University of Debrecen (UD) our research group focuses on Lifestyle and Health Sciences. We define health as a complex psycho-bio and social phenomenon and the overall goal is to promote, assist and implement Sustainable Lifestyle. However Sustainable Lifestyle has many corresponding scientific sub-categories, beyond our activities we concentrate on*

*(1) the present trends and future potential of sustainable food consumption, covering special consumer demands on functional food, organic, ethical, fairly traded, LOHAS-LOVOS and local products, plant-based diet and cultured (lab-grown) meat, sustainable European traditional pig (Fatty Pig) etc.,*

*(2) short food supply chain,*

*(3) renewable energy, and*

*(4) the economic, social, health preserving effects of physical activity.*

*Our aim is to run professional lifestyle studies focusing on actual research issues of Health Industry. Within the scope of Sustainable Lifestyle we wish to contribute to general awareness-raising about Health Economy with a special attention on social health-consciousness. Our proposal initiates future collaborations with CARPE members in the form of*

*1. Organisation of joint educational (bachelor, master and PhD) events;*

*2. Exchange of students;*

*3. Exchange of teaching and research staff;*

*5. Exchange of articles, publications and other scientific information;*

*6. Organisation of common scientific conferences.*

**Keywords:** *Sustainability, Short Food Supply Chain, Consumer Behaviour.*

---

## **1. Introduction**

The University of Debrecen is recognising the mutual benefits to be gained through strengthening the collaboration between higher education institutions, companies or other research institutes. Therefore our current project proposal focuses on establishing and deepening partnership and cooperation with the aim of stimulating R+D activities and enhancing innovation..

The Faculty of Economics and Business is the youngest faculty of the Debrecen University and the largest one regarding the number of its students (cc. 4000 students). The Faculty was created by the integration of the Faculty of Applied Economics and Rural Development, with the Faculty of Economics and Business Administration as of 1 August, 2014. As a result, the academic experience and scientific research of these two legal predecessors made up a pool of joint resources that provides a wide spectrum of educational and research services for both students and stakeholders. The educational fields of the Department encompass agriculture, economic, sports sciences, and humanities. The fame and popularity of the Faculty are also in evidence by the multiple academic fields on offer as well as the fact that the majority of our students continue their studies at the Faculty.

Our research community is exploring the academic field of Lifestyle and Health Sciences. Within this wide concept our team concentrates on the topic of Health defined as a complex psycho-bio and social phenomenon offering a tool to promote, assist and implement Sustainable Lifestyle. However Sustainable Lifestyle has many other corresponding scientific sub-categories the current proposal has chosen certain topics of Sustainability as potential future research activities together with CARPE members.

### *1.1. Sustainable food consumption*

We are interested in the present trends and future potential of sustainable food consumption, covering special consumer demands on functional food, organic, ethical and/or fairly traded products, in the size of LOHAS-LOVOS community in the partner country and in the structure and movement of local products. We would like to explore the potential and present popularity of plant-based diet and cultured (lab-grown) meat. We could introduce the success of sustainable European traditional pig (Fatty Pig) as a (Hungarian) best practice.

### *1.2. Short food supply chain*

With the help of analyzing the demand for sustainable food categories (see above) we could explore the institutional system (members and stakeholders) and infrastructures of locally grown/produced articles with a territorial focus of in CARPE countries. As short food supply chains get more attention these days it would be important to see good examples in



partner countries and set a strategy in order to further assist the expansion of short supply chains in the agrifood sector.

### *1.3. Renewable energy*

As set in the EU2020 strategy of the European Union renewable energy sector should be strengthened all over Europe. However Hungary is keen on to meet the target goals it still has space to develop the usage of renewable energy sources within the country. We would like to meet smart examples of the partnership that could be adoptable in Hungary, too.

### *1.4. Physical activity*

Similar to the renewable energy sector in case of physical activity Hungary has bad scores comparing to other EU member countries. It is commonly known that physical activity has got a relevant effects on the economy. Therefore social and health preserving outcomes of more or less physical activity should be analysed among CARPE members.

## **2. Potential means and areas of cooperation**

During a future project university students of various levels (bachelor, master, PhD) and research fellows could be involved in explorative activities (case studies, market research, collecting best practices, focus groups, etc.). Our aim is to run professional lifestyle studies focusing on actual research issues of the above mentioned topics. Our intention is that the results and findings of these studies will contribute to the development of the Sustainable Lifestyle.

We recommend the following potential means and areas of cooperation for the CAPR conference:

### *2.1. Organisation of joint educational (bachelor, master and PhD) events*

*2.1.1. Organisation of workshops and meetings* for students and research fellows of the partner Universities in order to support their research activities and broaden their overview upon a certain topic. These events could support the networking activities of students and professionals of the Faculties, and give opportunity to share information and research results with each other and to come up with new ideas regarding future activities.

*2.1.2. Defining common research/thesis/dissertation topics for the students of the two Faculties.*

*2.1.3. Providing supervisory activities for the students of the Partner institution:* linking students and research fellows and researchers and research fellows with the

relevant knowledge of the Partner institution in order to promote international aspect of the research and exchanging views on various issues.

#### *2.2. Exchange of students*

Student mobility and internship opportunity for students at the Partner Universities and companies of the certain country.

#### *2.3. Exchange of teaching and research staff*

Short-term mobility of teaching and research staff from/to the Partner University at the above-mentioned topics.

#### *2.4. Exchange of publications and other scientific information*

Common publications at the above-mentioned research topics, such as Sustainability, Sustainable Lifestyle, Sustainable Food Consumption, Effects of Physical activity, Health Industry, Health Economy, etc.

*2.5. Organisation of common scientific conferences such as Annual conference of Nutrition Marketing - Debrecen, Hungary.*

### **3. Expected results**

As an outcome of a future cooperation the Faculty of Economics and Business would like to further deepen CARPE membership and benefit from the knowledge and experience of the network of universities. Due to a strengthened cooperation between the partners the number of international publications and cross-national projects will rise effecting an increased reputation of the CARPE platform, too.

## Empowering Youth Employment through European Digital Bootcamps (EDIBO)

Jorge E. Luzuriaga<sup>2</sup>, Begoña Sáiz Mauleón<sup>2,3</sup>, Olga Ampuero-Canellas<sup>4,5</sup>, Lenin G. Lemus-Zúñiga<sup>1,2</sup>, Miguel A. Mateo Pla<sup>1,2</sup>, José V. Benlloch-Dualde<sup>1</sup>, Jimena González-del-Río<sup>4,5</sup>, Nereida Tarazona-Berenguer<sup>4,5</sup>

<sup>1</sup>Dpt. de Informàtica de Sistemes y Computadores, Universitat Politècnica de València (UPV), Spain, <sup>2</sup>Inst. Universitario de Tecnologías de la Información y Comunicaciones, (UPV), Spain, <sup>3</sup>Dpt. de Expresión Gráfica Arquitectónica, (UPV), Spain, <sup>4</sup>Dpt. de Ingeniería Gráfica, (UPV), Spain, <sup>5</sup>Centro de Investigación en Tecnologías Gráficas, (UPV), Spain.

---

### **Abstract**

*Information and Communication Technologies (ICT) are transforming every area of economic and social life all around the world. New types of jobs different from the traditional ones are created rapidly. The demand for highly skilled staff who uses technology effectively has become a requirement for success of companies and the growing industry.*

*However, the number of IT graduates is not enough to meet the growing current demand. In addition, many small and medium-sized enterprises have little or no training programs to develop ICT skills. Initiatives from the European Economic Area and Norway Grants to support transnational projects for Youth Employment such as EDIBO, contribute to increase the job opportunities for young people who are neither in employment nor in education and training (NEETs). In this way, the Sustainable Development Goal 8 which aims to “promote sustained, inclusive and sustainable economic growth, full and productive employment and decent work for all” could be fulfilled.*

*Nowadays, EDIBO is developing different training programs in order to achieve a success model of all processes involved with the organization, implementation and evaluation. The aim of the work is to show the process that has resulted in the first bootcamp, recently launched in Spain as one of the cases implemented within the European framework.*

**Keywords:** *Bootcamp; ICT; youth employment; social project; entrepreneurship.*

---

## 1. Introduction

According to the World Health Organization, unemployment is the biggest epidemiological catastrophe for many societies and one of the main factors of social marginalization (Marmot, 2005). Young individuals (from 15 to 24 years) have a greater risk of ending up unemployed than older workers (Caliendo & Schmidl, 2016) and their unemployment rates are generally much higher than total unemployment rates (European Union, 2018).

In 2017, Spain reported a 17.2 % unemployment rate; the second highest of all the countries of the European Union (European Union, 2018). The number of young people between 16 and 29 years is 6,540,600 of which 1,092,100 are no longer in the education system and who are not working or being trained for work (NEET). The situation is higher in the range of age from 25 to 29 years, as figure 1 shows. (Informe Jóvenes y mercado de trabajo, 2018).



Figure 1. Unemployment in Spain by age in percentage. Source: Informe Jóvenes y mercado de trabajo, 2018.

In order to reduce these unemployment rates among young people, governments and institutions implement Active Labor Market Programs (ALMP) (Caliendo & Schmidl, 2016). One of them, labour market training, includes any training intervention aimed at reinforcing their knowledges and skills. These programs are especially effective when there is an educational mismatch because courses and training permit to balance the unemployed skills with companies needs (Caliendo & Schmidl, 2016).

Moreover, the International Telecommunications Union states that there will be tens of millions of jobs available for people who possess advanced digital knowledge and skills (Abbas & Natta, 2018). Therefore, a training program in digital tools could increase the job opportunities of these unemployed young people, promoting their integration into the labor market.

To address this situation EDIBO project was launched, with the aim to enhance the employability of NEETS through formation in the area of ICT, with a special focus on people at risk of social exclusion.

This European project is funded by Iceland, Liechtenstein and Norway through the EEA and Norway Grants and is being developed by seven partners: Three Thirds Society NPO (Greece) (Lead partner), Paralel-Silistra (Bulgaria), Foundation for Society (Latvia), Integration Centre (Lithuania), National Craftsmen Confederation Lecce (CNA Lecce) (Italy), FORMA.LAB SRL (Italy) and Universitat Politècnica de València (UPV) (Spain). The project lasts 36 months and began on 1st October 2018.

The remainder of this paper is structured as follows. Section 2 describes the methodology used in the project indicated by the Lead Partner. Section 3 presents the experimental part with the case study of the first EDIBO bootcamp in Valencia. Section 4 presents the results observed after 4 weeks of learning, and finally, section 5 with the conclusions describing both, the attitudes, behaviours and results of the knowledge acquired and the ongoing commitment by the collaborators enterprises.

## **2. Methodology**

We proceed to comment the methodology established for the development of the bootcamps. This explanation is divided into five sections: network creation, syllabus, phases, target group and communication strategy.

### **2.1 Network Creation**

Each EDIBO partner is responsible for designing, planning and running six bootcamps (two per year) based on the IT needs of the small and medium enterprises (SME) located in their regions. To do that each partner must create in its region a network composed of different stake holders: (i) SMEs, (ii) local and regional entities or associations, (iii) bootcamp participants and (iv) learning centre.

### **2.2 Syllabus**

The project IT Expert Board must analyse the IT demands and needs of companies and then develop an intensive “digital training lab” adjusted to the needs detected. The model is inspired by the new “Rapid Technology Skills Training” of the World Bank, (Mulas 2019).

### **2.3 Phases**

Training is carried out in two phases. First, students complete 200 hours of face-to-face classes and 200 hour internship in a company. The aim of the first phase is to enhance the technical knowledge in relation to some digital skills, and to strengthen English language and soft skills such as teamwork and entrepreneurship. Regarding the second phase, the objective is that students be involved in real projects within companies, in such a way they could increase their experience, self-esteem and self-confidence to obtain a job. This is especially

important in those students who do not have any previous work experience (Caliendo & Schmidl, 2016).

#### **2.4 Target group**

The target group for the EDIBO training activities are unemployed young people aged from 18 to 29 who are neither studying nor working, with a special focus on the range 25-29 that comes from disadvantaged groups e.g. low-income, migrants, youngsters from rural areas. These are the characteristics that will guide the selection process of students.

Considering also that women are retreating from the fields of science and technology at alarming rates (Albert, 2016) creating a wide gender gap over the years (Castillo, 2014), EDIBO project plan to involve as many women as possible in the bootcamps, with the aim of having at least 35% female participants.

#### **2.5 Communication strategy**

The project has a communication plan whose primary goal is the widespread promotion and visibility of the project objectives and activities. It is also important to raise awareness and motivate young people and enterprises to participate in the bootcamps as students or sponsors.

The communication activities planned can be separated into three categories: conference organizations or info-days, mass communication media and publicity activities. Mainly social networks (Facebook, Twitter and YouTube), newspapers (digital editions) and radio will be used for the dissemination of messages.

### **3. Experimental**

Next, we describe the development of the first bootcamp carried out in Valencia applying the methodology explained in the previous section. This first bootcamp, “Bootcamp 1: Full-Stack programmer with MEAN”, started 3th of June and will run until 12th of August 2019. The number of students is about 25, four of whom are women.

First, we contacted the following entities to create our first local network of collaborators:

- local SMEs: They helped us to define the profiles to obtain the IT needs to be able to pass the results to the IT Board to define the syllabus of the first bootcamp. In addition, some of them offered internship to bootcamp students.
- local and regional entities: Provincial Council, Official Association of Engineers, Chamber of Commerce and municipal transport company, among others. They joined to collaborate (a) in the diffusion of the project among their partners, (b) advertising the project to the

society using the urban city buses, and (c) connecting with similar projects to exchange experiences.

- learning centre: a centre specialized in the development and implementation of training courses related with IT, was selected to share teaching activities.

The analysis of the IT local SMEs shows that Full Stack programmer is one the most demanded profile. Therefore, the content of the First Bootcamp was focused on the Full Stack developments. Table 1 shows the modules of this Bootcamp and their duration.

1	2	3	4	5	6	7	8	9	10	11
NODE+ Express	MYSQL	MONGO	Angular	React/ JEST	Scrum	Soft skills	Colour theory	Entrepreneurship	HTML/CSS-SASS	English
24 h	20 h	24 h	24 h	24 h	24 h	4 h	4 h	4 h	8 h	40 h

Table 1. Training modules in the First Bootcamp "Full-Stack programmer with MEAN".

EDIBO is much more than a labor market inclusion project. We believe that part of the project's success is based on emotional recover and self-confidence and that the approach of the project must to be based on human rights, seeking the integration of the values, principles and norms of the international human rights system into development plans, policies and processes (Fernández et al., 2010). Therefore, soft skills have been included in the courses.

Regarding teachers, most of them come from the academia, with a large teaching experience. However, there are some particular topics that need to be covered by people from companies. For example, the entrepreneurship module is taught by professionals who, in their professional life, are facing similar situations.

To select the 25 students, in addition to their personal data, two official documents were required: an identification card and the unemployment card. These documents will be used to validate the participants' age, home address and gender, and to observe the current status of unemployment and the time it takes in.

After analysing this information, people that not fit with the requirements were discarded and people that fit with were contacted by telephone/e-mail to make an interview. Then, the documentation was checked and a few questions regarding the motivation to participate in the bootcamp were raised.

Regarding the communication strategy used to promote the project, we considered that 86,4% of the Spanish population has access to the Internet, being the main type of broadband

connection via a mobile phone (INE, 2019). So, two main processes have been defined: generic social networks campaigns and direct contact with associations representing potential students and firms (like Non-Government Organizations, local governments and the University Centre for Postgraduate Studies).

Also, two info-days were organized, in Valencia and Lliria, to raise awareness of EDIBO. Both obtained a good impact on the media, especially in local and regional digital newspapers.

#### **4. Results**

One of the best indicators of the success of the programme will be the number of trainees recruited at the end of their training period. Upon completion of the project, in 2021, the Spanish partner hopes to give IT formation at 150 unemployed youngsters and a tuition to promote entry into stable employment relationships.

As of July 2019, the first bootcamp has not yet finished, students are now in the face-to-face classes period, and it is only possible to report partial results. Therefore, it is too early to measure the impact of the bootcamp based on achieving social and educational objectives.

At present, five SMES have agreed to receive 20 students in internship programs, provided they finished the first training period. Human resources staff, from the learning centre, guides the internship of the students after an interview.

Different tests have been designed in each module to monitor the participants progress in their formation. For the moment all the students have passed these exams. This indicates that learning outcomes are been reaching. In addition, feedback from participants is received and registered by teachers in order to make a report.

After the first 25 sessions the teachers experience can be summarized as follows: i) understanding about web technology has improved; ii) students have learned to process the knowledge before applying it; iii) the more advanced students are helping the rest of the companions generating a good atmosphere in the course; iv) the level of self-esteem has increased; v) a transition from a skepticism feeling to a motivated inspiration has been detected; vi) in general the relationships between students are very good; vii) students have limited skills for self-learning; and viii) students required constantly attention from the teacher.



## **5. Conclusions**

Youth unemployment rates (NEETs) in Spain and Europe are a problem of concern to governments and institutions. On the other hand, digital development has created a large number of jobs. The union of these two realities gives rise to the EDIBO project, whose main objective is to improve youth unemployment by offering young people, especially those at risk of social or labour exclusion, a period of ICT training and work experience in companies.

Throughout, this document, all the stages developed by the Spanish partner for the execution of his first bootcamp are described with the aim to allow a rapid replication of the intensive ICT training in a social innovation community.

The preparation and implementation of this first bootcamp allowed us to draw the following preliminary conclusions.

Firstly, it is difficult to implement the same bootcamp in different geographical, social, economic and cultural areas like the ones involved in EDIBO. Therefore, it is important to apply the maximum to “plan globally but act locally”. The lead partner operator has to contemplate the possibility of adapting the processed and activities to the idiosyncrasy of each region.

For instance, it was supposed that the content definition of bootcamp could be the same for all the partners, but then the experts agreed that the courses’ contents should be adapted to the particularities of each partner.

Secondly, the possibility of adapting the program to the characteristics of each organization should also be considered. In the EDIBO project, five partners are NGOs but there is also a private institution and a public one whose structure and working mode differs in some points from the previous ones.

Thirdly, a project of this type can only get ahead with the close collaboration of SMEs and institutions (public or private). Companies collaboration is necessary firstly to define their IT needs and secondly to receive students during their internship period. The support of the institutions is important increase the project visibility as well as to reach companies and potential students in a quicker and easier way.

Concerning students, it has been observed that in certain cases the upgrading of their skills in IT technologies may not be enough to improve their employability. To overcome these difficulties, we have programmed three transversal skills modules out of a total of eleven purely technical content modules.

Finally, it is important to highlight that projects like this one contribute to the achievement of the Sustainable Development Goal 8. It is a way to strive that countries and their societies will be able to improve the lives of all, without leaving anyone behind.

## References

- Abbas, A. B., & Natta, W. (2018). How digital skills can help tackle youth unemployment. In *International Trade Forum* (No. 2, pp. 22-23). International Trade Centre.
- Albert, C., & Breternitz, R. (2016). *Empowering Women's Success in Technology*. Center for work & family.
- Archibald, R., Di Filippo, I., & Di Filippo, D. (2012). The six-phase comprehensive project life cycle model including the project incubation/feasibility phase and the post-project evaluation phase. *Pm World Journal*, 1(2012), 1–33. <https://doi.org/10.1016/j.jnoncrysol.2017.02.013>
- Caliendo, M., Schmidl, R. (2016). Youth unemployment and active labor market policies in Europe. *IZA Journal of Labor Policy*, 5(1), 1-30.
- Castillo, R., Tacsir, E., & Grazzi, M. (2014). *Women in Science and Technology: What Does the Literature Say?* | Publications. Inter-American Development Bank, (February), 32. Retrieved from <https://publications.iadb.org/en/publication/11913/women-science-and-technology-what-does-literature-say>
- European Union (2018) *Key figures on Europe. STATISTICS ILLUSTRATED*. 2018 edition. Luxembourg: Publications Office of the European Union, 2018. ISBN 978-92-79-77871-1 ISSN 2315-201X doi: 10.2785/594777
- Informe Jóvenes y mercado de trabajo. Subsecretaría de Trabajo, Migraciones y Seguridad Social. Dirección General de Estadística y Análisis Sociolaboral. Junio 2018. Ministerio de Trabajo, Migraciones y Seguridad Social. Gobierno de España. Retrieved July 1, 2019, from [http://www.mitramiss.gob.es/es/sec\\_trabajo/analisis-mercado-trabajo/jóvenes/numeros/2018/junio\\_2018.pdf](http://www.mitramiss.gob.es/es/sec_trabajo/analisis-mercado-trabajo/jóvenes/numeros/2018/junio_2018.pdf)
- Fernández Juan, A., Borja Segade, C., García Varela, P., Hidalgo Lorite, R. (2010). *Guía para la incorporación del enfoque basado en derechos humanos en las intervenciones de cooperación para el desarrollo*. Instituto Universitario de Desarrollo y Cooperación de la Universidad Complutense de Madrid. NIPO: 502-13-045-4
- Ignacio, G.-P., & Pilar, C. G. M. (2013). The use of social technologies in Spanish young people: a global behaviour model in teenagers. *Global Business Perspectives*, 1(4), 289–308. <https://doi.org/10.1007/s40196-012-0006-z>
- INE, (2019). *España en Cifras 2019*. Instituto Nacional de Estadística. NIPO:10419-002-2
- Marmot, M. (2005). Social determinants of health inequalities. *The lancet*, 365(9464), 1099-1104.
- Mulas, V., Paradi-Guilford, C. M., Allende Letona, E., & Dalphond, Z. V. (2017). *Coding bootcamps: building future-proof skills through rapid skills training* (English). Washington, D.C.: World Bank Group. Retrieved July 1, 2019, from <http://documents.worldbank.org/curated/en/795011502799283894/Coding-bootcamps-building-future-proof-skills-through-rapid-skills-training>
- “Social Determinants of Health. The Solid Facts” (OMS, 2003). [http://www.euro.who.int/\\_\\_data/assets/pdf\\_file/0005/98438/e81384.pdf](http://www.euro.who.int/__data/assets/pdf_file/0005/98438/e81384.pdf)

## **eSGarden: a European initiative to incorporate ICT in schools**

**Sara Blanc<sup>1</sup>, José V. Benlloch-Dualde<sup>2</sup>**

<sup>1,2</sup> Computer Engineering Dept., Universitat Politècnica de València, Valencia, Spain.

---

### ***Abstract***

*Knowledge transfer to the society is undoubtedly one of the main objectives of Universities. However, it is important that these advances reach the youngest, many of them, future university students. Having this in mind, a European project around how incorporating ICT in school gardens was proposed (SCHOOL GARDENS FOR FUTURE CITIZENS, 2018-1-ES01-KA201-050599). In this project, both universities and schools, belonging to five European countries, are collaborating with public and private organizations with social concerns, environmental responsibility and sustainability.*

*School gardens is a broad topic that combine technological needs for managing and control with education in values of environmental sustainability, social inclusion and citizenship, transmission of tradition, and the promotion of digital culture in both girls and boys from the early school stages. These last aspects are aligned with some sustainable development targets (SDGs), such as ensuring healthy lives and promote well-being for all at all ages, inclusive and equitable quality education, gender equality or responsible consumption.*

*A further challenge of the consortium is to extend the proposed approach to other schools throughout Europe with the same interests and impact, considering cultural diversity and climate differences.*

**Keywords:** *School gardens; sustainable development goals; digital competences; inclusive education.*

---

## **1. Introduction**

The defence of school gardens and its advantages in education is not new. For example, the network Eco-Schools (<https://www.ecoschools.global/>) groups 51.000 schools of 67 countries. They define themselves as the largest global sustainable schools programme – it starts in the classroom and expands to the community by engaging the next generation in action-based learning. In the last years, different projects have been funded from the European Union within the framework of the Erasmus+ program. For instance, "Erasmus Gardening: Culture and Science" (<https://erasmusgardening.poli.hu/>) or "gARDENS to gROW: Urban Horticulture for Innovative and Inclusive Early Childhood Education" (<http://www.distal.unibo.it/it/ricerca/progetti-di-ricerca/attivi/gardens-to-grow-urban-horticulture-for-innovative-and-inclusive-early-childhood-education>), the last one still in progress until 2020.

All the former initiatives highlight school gardens as a learning vehicle that help students to reach many different goals. A holistic learning approach encourages knowledge of social, economic and cultural understanding of the regions in which students live. Moreover, it will promote both specific and soft competencies, and prepare students for a global world in continuous change. Adding the ecological approach, schools' gardens also promotes values for future citizenship towards respect for the environment and responsible behaviour, sustainable production of food or healthy nutrition. For example, FAO, in its document "A NEW deal FOR school gardens " (Food and Agriculture Organization, 2010) promotes the use of school gardens as well as the application of Garden Based Learning (GBL) methodology (Desmond, Grieshop & Subramaniam, 2004).

General speaking, school gardens deal with many Sustainable Development Goals (United Nations, 2015) such as “ensure healthy lives and promote well-being for all at all ages” (SDG 3); “ensure inclusive and equitable quality education and promote lifelong learning opportunities for all (SDG 4); “achieve gender equality and empower all women and girls (SDG 5); or “ensure sustainable consumption and production patterns” (SDG 12). Hence, school gardens offer a big opportunity to invite students to look ahead and contribute in the world transformation, according to the *2030 Agenda for Sustainable Development*.

Technology is well received by the new digital generations and the ICT affordances are undoubtedly very valuable. However, the introduction of technology is not always tackled in the proper way. There is a consensus in the research available that the primary factor that influences the effectiveness of learning is not the availability of technology, but the pedagogical design for effective use of ICT (BECTA, 2004; Wang & Woo, 2007). Therefore, provided that pedagogical approaches are considered, ICT can be incorporated in formats better accepted by all students as a means of observing the reality, sharing

knowledge, stimulating creativity, stoking the initiative and empowering students in their own learning.

eSGarden (School Gardens for Future Citizens) is a project (2018-2021) funded by the **Erasmus+ programme under the KA2: Cooperation for innovation and exchange of good practices** (<https://ec.europa.eu/programmes/erasmus-plus/projects/eplu-project-details/#project/2018-1-ES01-KA201-050599>; <https://esgarden.blogs.upv.es/>). This project proposes an innovative technology transferring pilot which pretends to bring the garden to the classroom activities through the creation of a virtual environment. The purpose is to transform garden observation and work in data and information which allow teachers on the one hand, to build their own educational resources and, on the other hand, to establish a connection between the physical world (garden) and the digital one (virtual), linking informal activities outside the classroom with the content of the curricula. It eases the integral development of the students, helping to improve their self-esteem and personal satisfaction because the activities carried out are highly motivating and link the process of learning with the development of both personal and academic skills. Moreover, school gardens improve the relationship between the community and the school, since social and educative networks are created, fostering the feeling of belonging to a bigger community.

## 2. Project partners

The project partnership is integrated by primary and secondary schools, universities, a non-profit organization and a small agro-technology company. Among schools, Spain, Portugal, Slovenia and Greece are represented. Among non-school partners, there are three universities: *Universitat Politècnica de València (UPV)*, in Spain; *Universidade do Porto (UP)*, in Portugal; and *Universitatea Tehnică Cluj-Napoca (UTCN)*, in Romania. Moreover, the consortium incorporates *Fundación CajaMar*, a Spanish non-profit organization, and a small company, *TBAgroSensors S.L.*, located in Valencia, Spain.

*La Purísima Franciscanas school*, in Valencia, will provide knowledge and advice about the definition of good practices in building the school curriculum around gardens. It will lead the methodological approach and the schools coordination. This school together with *Smartno pod Smarno Goro Primary school*, in Ljubljana, Slovenia; *Agrupamento de Escolas de Paredes*, in Porto, Portugal, and the *4<sup>th</sup> of Primary School*, in Preveza, Greece, serve as tester and will get quality feedback about the design of school gardens activities and educational resources created starting from collected gardens data. Schools are a fundamental part in the development of this new methodological approach, its quality evaluation and the resources production to support future project sustainability.

*Preveza*, in Greece, participates through the *Directorate of Primary School Education*. This organization is responsible for 38 general education nursery schools and 31 general primary

education schools. It employs approximately 537 teachers and about 4090 students are currently enrolled in its schools. Its role is to coordinate, supplement, support and implement the educational policies of the Ministry, coordinate and guide the work of schools and lead initiatives. It will coordinate the project, activities and testing, within a suitable group of students' participants from Preveza.

UP is involved into the project through the *OBVIE* department for advising on how teachers' activities around the school garden can be pedagogically adequate, in order to increase quality of the materials and their impact on students' learning. It is relevant to point out that an especial focus will be placed on low achievers and families with low incomes and disadvantaged social backgrounds. OBVIE will lead the supervision and evaluation about the establishment of necessary principles, targets and approaches to ensure the objectives of development and global citizen education. The *Centre for Development Cooperation* at the UPV will collaborate in the task with the advised supervision of associated partners.

*Fundación CajaMar* is focused on supporting teacher and administrative staff in schools with training activities around agriculture uses and its adaptation to school gardens and healthy nutrition, as well as its impulse through school gardens. It leads the screenplay book on school gardens in both paper book short edition and free access electronic format.

UPV is responsible for the project coordination, management and dissemination. It leads research and development of ICT tools and materials. This task requires of developing the virtual garden and activities around this topic. The UPV will provide schools, teachers and schoolchildren with ICT transferable knowledge to them. In particular, it will offer elearning know-how that present success cases with potential adoption by schools and help them to develop ICT resources. It also will provide expertise about crops, tillage and irrigation culture from former studies. Finally, cooperation with the *Senior University* (<http://www.upv.es/entidades/AUS/index-en.html>), will help to increase synergies and links with culture in a circular knowledge.

UTCN will contribute in the research and development of ICT tools and materials as well as in supporting teachers training to adopt the new digital paradigm, according to the European Framework for the Digital Competence of Educators (Redecker, 2017).

*TBAgrosensors* will develop open-source resources to adapt commercial agro-field instruments, such as soil-moisture probes, water counters and electrovalves, to the programme within technology activities oriented to children and young people to work by themselves on the configuration and deployment of small-electronics equipment to control their school gardens.

All partners will be involved in disseminating project results both locally, through actions such as workshops or presentations, and internationally, through papers in journals and international conferences.

### 3. Objectives

On a pilot experience it is possible to define targets, to observe deficiencies on needs and to create a suitable and adapted ICT environment accepted by students, teachers and in general, throughout the educational community.

The school gardens combine technological needs for managing and control with education in values. In particular, themes than can be addressed are: environmental sustainability, social inclusion and citizenship, transmission of tradition and the promotion of digital culture in both girls and boys from the early school stages, as shown in Fig. 1.



Figure 1. A project with four axes.

It is a challenge to carry out this integration so that it can be extended to other schools throughout Europe, provided they have the same interests and, of course, taking into account cultural diversity and climate differences.

In summary, the project mission is to work on good practices, tools and resources which help to a broad community to create and produce adapted educational resources to their own needs to improve students' specific and soft skills, language skills and social education.

#### 3.1. Specific objectives in social learning

The project focuses on developing knowledge in digital project-based learning around an inclusive programme which promotes equality of opportunities by giving an individual education, fosters students' implication, solidarity and cooperation.

Thus, it is essential to design a learning methodology based on the adoption of school gardens in the school's curriculum within an ICT approach. During the project, research on school gardens project-based methodology will be implemented and tested in the schools' partners defining good practices and activities. The methodology will be implemented as a programme to primary curriculum in a transversal design on different topics such as environment, society, economy, nutrition, among others. Relevant improvements will be focused on linguistic, technological, cultural and social skills.

### ***3.2. Specific objectives in digital based learning***

As a case study, the project connects gardening and technology under a learning-by-doing project. Non-school partners will contribute on developing ICT tools and resources to promote children virtual interaction with the school garden. It is considered useful to save data about garden activities that can enable to work on skills such as deduction, critical thinking or collaborative learning through gamification. Moreover, diversity is contemplated through the adaptation of interfaces for children with special needs.

### ***3.3. Specific objectives in circular community knowledge***

The third objective is to transform school gardens into circular knowledge breaking down frontiers in a global expansion throughout a diverse community. In this line, the project contributes with both activities and output resources.

Activities such as selling markets, will connect the school with the surrounding community. To accomplish that, these activities are carried out with the collaboration of seniors, families and neighbours, to promote the immersion of learning in the community. The culture and agro-knowledge transfer is the base stone of this objective which focuses on local traditions and respect.

Moreover, the project works on tangible intellectual outputs to help schools to adopt the methodology.

### ***3.4. Specific objectives in learning-by-doing***

Improve quality, motivation and students' achievement through a more attractive holistic real-life based programme close to children and, in turn, innovative, where they can propose ideas, make decisions and acquire responsibilities. "Thinking out of the box" is the life-motive that connects gardens + technology + progress in an equation which results in innovation, creative stimulation and responsibility.

## **4. Working Plan**

The principles of eSGarden are:



- To produce knowledge transfer from University and non-school partners that serves in the improvement of school practices and activities.
- To gain feedback of school necessities and curricula gaps to promote students' learning in current technology advances and social awareness.
- To stimulate the adoption and integration in the schools curricula of new competencies that stimulate talent around the project topic.

Taking these principles into account, the working plan is distributed in three main Work Packages (Fig. 2):

- 1) WP1: Define a suitable consortium which embrace the expected knowledge in Education, SDGs and Social Learning, ICT Systems, Scholar Programmes and Development, Agro-Food knowledge and Quality Audit.

Project start-up focuses on defining goals, challenges and limits in the schools curricula adaptation. Actions such as internal conferences, face-to-face meetings, evaluation questionnaires or a school teachers intensive training are arranged tools to approximate the interests of each school to the possibilities of knowledge transfer. As each participating school belongs to a different country, they have also diverse legislative frameworks. Therefore, it is necessary to adapt project outputs to each context.

- 2) WP2: The second work package is set around defining eSGarden contributions in four axis: Education and Social Approach, Education Strategy, Students and Community Interaction and Quality Measurement.

This work package requires the definition of a methodological approach to set the educational competences that could lead the change. The strategy will be spread on daily classroom work where proposals will be deployed and observed to distill good practices than can be portable and adaptable to other school contexts.

- 3) WP3: Finally, the third work package defines the observation throughout Key Indicators useful to measure the qualitative competencial improvement on students, teachers and the community.

eSGarden has defined a set of tangible outputs to multiply the impact of the change to be transformational, innovative, useful and measurable. These project outputs will be ready at the end, in may 2021.

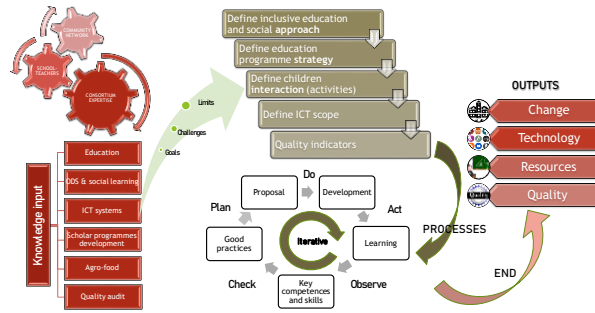

Figure 2. Working plan view.

Fig. 3 shows a schedule of eSGarden milestones. M1 to M5 represent the transnational meetings which will be held during the project in each of the five countries represented in the project: Spain, Portugal, Slovenia, Greece and Romania.

Among the activities included in WP1, schools have to introduce the project to their community with activities around European awareness, such as designing a logo or building new spaces for gardening. Moreover, the team of teachers involved in the project must get recognition in the institutions to facilitate authority to drive future changes.

WP2 includes activities around aspects directly or indirectly linked with gardening and the technology as vehicle. Furthermore, the project is also focused on nutrition, personal development as learners or digital empowerment.

Finally, WP3 includes conferences, papers and workshops where the project outcomes be disseminated.

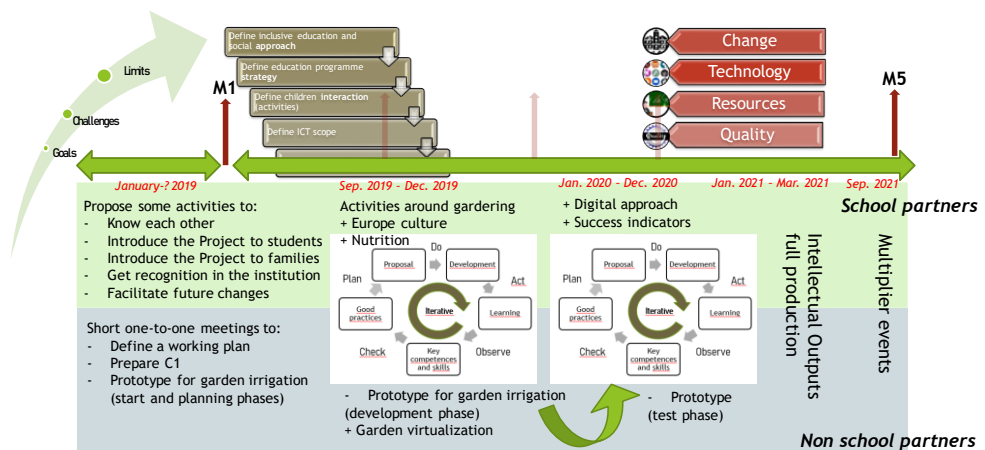

Figure 3. Project route map.

## 5. Conclusions

This paper presents an in progress knowledge transfer project around how incorporating ICT in school gardens. This broad topic has the advantage of combining technological needs for managing and control, together with education in values, as it addresses themes such as environmental sustainability, social inclusion and citizenship, transmission of tradition and the promotion of digital culture in both girls and boys, from the early school stages. Many of these aspects are aligned with some SDGs, according to the *2030 Agenda for Sustainable Development*.

A further challenge of the consortium is to extend the proposed approach to other schools throughout Europe with the same interests and impact, considering cultural diversity and climate differences.

## Acknowledgment

This project is funded by Erasmus+ KA2 Supporting Innovation Action (project number: 2018-1-ES01-KA201-050599 and SEPIE Spanish Service for the Internationalization of Education (2018): <http://sepie.es/>

## References

- BECTA (the British Educational Communications and Technology Agency) (2004). *A review of the research literature relating to ICT and attainment*. Retrieved July 1, 2019 from [https://www.researchgate.net/publication/265003809\\_ICT\\_and\\_Attainment\\_A\\_Review\\_of\\_the\\_Research\\_Literature](https://www.researchgate.net/publication/265003809_ICT_and_Attainment_A_Review_of_the_Research_Literature)
- Desmond, D., Grieshop, J., & Subramaniam, A. (2004). *Revisiting garden-based learning in basic education*. FAO and UNESCO-IIEP. Retrieved July 1, 2019, from <http://www.fao.org/3/a-aj462e.pdf>
- Food and Agriculture Organization of the United Nations (FAO). 2010. *A new deal for school gardens*. Retrieved July 1, 2019 from <http://www.fao.org/3/i1689e/i1689e00.pdf>
- Redecker, C. (2017). *European Framework for the Digital Competence of Educators: DigCompEdu*. Punie, Y. (ed). EUR 28775 EN. Publications Office of the European Union, Luxembourg. doi: [10.2760/159770](https://doi.org/10.2760/159770)
- United Nations. (2015). *Transforming our world: the 2030 Agenda for Sustainable Development*. Retrieved July 1, 2019 from [https://www.un.org/ga/search/view\\_doc.asp?symbol=A/RES/70/1&Lang=E](https://www.un.org/ga/search/view_doc.asp?symbol=A/RES/70/1&Lang=E)
- Wang, Q. & Woo, H. L. (2007). Systematic planning for ICT integration in topic learning. *Educational Technology and Society*, 10 (1), 148-156.

## Theoretical and Empirical Background for a Higher Education Model of Active Community Learning

Gabriella Pusztai<sup>1</sup>, Zsuzsanna Demeter-Karászi<sup>2</sup>, Tímea Szűcs<sup>3</sup>

<sup>1</sup>Institute of Educational and Cultural Management, University of Debrecen, Hungary,

<sup>2</sup>Institute of Educational and Cultural Management, University of Debrecen, Hungary,

<sup>3</sup>Institute of Educational and Cultural Management, University of Debrecen, Hungary.

---

### **Abstract**

*The intertwining of research and education at CHERD Higher Education Research and Development Center (CHERD) at the University of Debrecen performed several basic and applied research on Higher Education. Debrecen is a typical regional HE institution with international attraction in the peripheral area of EU. We performed a series of student surveys during the last decade, and we had the opportunity to reveal the process of gaining ground of non-traditional students in HE. Our center provides an inspiring context for researchers, where they have opportunity to discuss their formulating new research directions and to interpret data and research results together. The Center supports talent explorations and -development. Both MA/PhD students and researchers with great experience work together as a learning community. Thus, the mutual transfer and exchange of experience makes possible a continuous teaching-learning process during the research. Further more the concentration of professional development increases a special form of social capital.*

**Keywords:** *research and education; higher education research; talent management; reform process.*

---

## **1. Introduction**

The Centre for Higher Education Research and Development (CHERD) at the University of Debrecen plays an essential role in the educational and talent development activity of the institution. One of the most important aspects of the multidimensional relationship is to involve students in the activity of the research centre, thus creating an opportunity for them to learn how to interpret scientific literature, to formulate questions and hypothesis, to carry out research tasks, and last but not least, to write articles and conference presentations. We offer training for students who wish to continue their studies at a higher level and for those who wish to take part in competitions. In order to achieve our goals, students need to work on real projects, not fictitious ones, and learn how to work in a team in which each member's idea is equally important and they all equally contribute to the end result. This in practice is the active learning pedagogical model in higher education. During the active learning students participate in planning, they get the opportunity to analyze, to synthesis and also to evaluate (Bonwell&Eison, 1991). The criterion of the active learning is that the students have to carry out a responsible task (Bolden et al., 2017). The present research is an overview of the theoretical and empirical results underlying this higher education teaching method<sup>1</sup>.

## **2. The transformation of faculty roles**

According to European university traditions the teacher–student relationship is basically confined to scientific communication by means of which teachers publicly express their scientific views, while students engaged in their studies, formulate questions, or sometimes debate (Szczepanski, 1969). The differentiation of the roles of higher education (Castro&Levy, 2001), as well as the rising numbers of students has led to the separation of the functions of teacher and researcher, and has given rise to role conflicts in higher education<sup>2</sup> (Szczepanski, 1969; Clark, 1987; Kozma, 2004). Teachers and students were distanced not only by the difference in age but also by the pressure of symbolic power asymmetry, which further deepened the generation gap. Bourdieu found that pedagogical relation is not merely a matter of communication and that there is a strong correlation between linguistic capital and the selection taking place during the first academic years. Students' understanding and language use serve as a basis for teachers' evaluation. Language is not merely a means of communication but rather a system of categories hereditary transmitted, characterized by logical and aesthetic features which constitute a long lasting characteristic of students (Bourdieu, 1988).

According to Bourdieu teachers possess inherited (place of living, parents, status, denomination) and acquired (career, titles, awards) capital. The academic community, which Bourdieu considers a conservative community protecting its position, is led by

---

<sup>1</sup> An earlier version of the study was published in Hungarian in one of the chapters of Pusztai (2011).

<sup>2</sup> Further research could be carried out on the effects of career opportunities and the social position of this occupational group on teachers' behaviour pattern. The present study does not address this issue.

people in administrative positions. They enjoy the capital of academic authority, which in principle does not depend on scientific excellence. It takes a large amount of time to accumulate it, however it ensures power over the internal network of the institution. The group is characterized by a traditional spirit, newcomers are carefully selected, rigorously targeted, and melted in, i.e. co-opted. They can join the privileged circle of faculty after long waits for inheriting certain positions, in order to climb the rungs of the ladder. In the American literature of the field a contrast is drawn between teacher and researcher, i.e. higher education staff either dedicated to teaching or doing scientific research. Bourdieu, on the other hand, makes a distinction between an administrative or an academic career.

He draws attention to the fact that the crisis in higher education caused changes not only in the student community but also in teacher dispositions. A number of professors, invoking the preservation of elite education, insist on competitions and “numerous clausus” for both student and teacher advancement (Bourdieu, 1988). The security of the career path of those who wish to maintain the rules for academic advancement has deteriorated. A part of the emerging faculty has chosen the rapid return on knowledge capital (money, public honour) avoiding the time- and energy- consuming promotion rites, and departing from academic conventions, which were characterized by patience and performance-based eligibility. Nonetheless, in this model, neither the traditional nor the changed roles of teachers facilitate students’ successful career (Pusztai, 2011).

### 3. Lonely students in crowd

Besides changed teacher roles, the relationship in question is also influenced by the fact that higher education has shifted toward an economic subsystem. Profit maximization has become one of the fundamental values of academics, or in some cases it has even replaced these values and has led to increasing alienation and anomie among students. Some claim that alienation can be associated with the lessening of requirements and the time needed for study (Bryson&Hand, 2007); others blame it on the decline in career opportunities during and after study (Bourdieu, 1988; Bargel et al., 2009).

A number of researchers claim that higher education institutions are breeding ground for student loneliness, and personal relationships are the only counterbalance for the feeling of impersonality within the institution (Pusztai, 2011). Alienation is one of the major components of student isolation. Students feel that they are not treated as individuals; at best they are treated as clients. The focus is only on their performance, absences over a prolonged period are not noticed, and they are never approached by anyone. According to German researchers one third - two fifths of students are affected by these phenomena (Bargel et al., 2008). Research results show that teachers’ unapproachability and the high rate of students lacking contact varies among institutions and academic disciplines<sup>3</sup>.

---

<sup>3</sup> At universities half as many are experiencing relationships as at colleges. More than one third of the students of humanities and natural sciences maintain some kind of contact with their teachers, while in the case of students of law and economic sciences this ratio is only one sixth (Bargel et al. 2008).

Nonetheless, there is little information on how students of different social backgrounds are affected by this<sup>4</sup>.

A number of specialized institutional services have emerged within higher education institutions trying to tackle this problem (Harper&Quaye, 2009). However with lower-status students this solution is not always viable. They profit less from the help of specialist; they rather turn to their teachers because they are deterred by the client approach of these targeted institutional units (Thomas&Jones, 2007; Greenbank&Hepworth, 2008). The great hope, the internet, has somewhat improved the rate of those experiencing relationship, however it has very slightly reduced students' perception on and their dissatisfaction with isolation (Bargel et al., 2008).

#### **4. The importance of student-faculty relations**

“Being taken into account”, the perception of genuine concern has a particularly important impact in the world of education (Pusztai, 2008). It is not new, that social competences are usually the most important expectations student have from their teachers. These are what serve as a basis for an ideal picture of a friendly, understanding, helpful and likable teacher (Szczepanski, 1969). In the process of verifying Coleman's asymmetric effect thesis we pointed out that lower-status students place more value on teachers' attention (Pusztai, 2009a). Research on efficient learning also points out that the positive role of a teacher takes effect if the dimensions of interpersonal relationship encompass all aspects of students' personality (being treated as a person, being greeted, getting feedback, and being complimented) (Gaskó&Kálmán, 2014; Márkus&Engler, 2019).

As regards behaviour patterns related to the educational role in each institution, or rather within a faculty, a special consensus takes shape. This is perceived by newer generation of student as natural environment. Consequently, students lacking any point of reference can hardly reflect on this issue, except students who come from other institutions. Even though these local behaviour standards are difficult to measure, their contribution to the student environment is a key building block of student's commitment, since their role fulfilment is heavily dependent on those who play a complementary role (Szczepanski, 1969).

Studies on how teachers perceive their own role show a significant uncertainty in this area. Contrasting students' and teachers' conceptions, it is unequivocal that while students find it useful and important to have a relationship based on trust and informal communication with their teachers, the latter give voice to their disappointment with students and consider that it is in the student's own interest and responsibility to be committed (Bryson&Hand, 2007). Another approach considers that a student- teacher relationship based on personal contact can pose an ethical risk, given the dangers of the duality of official and personal relationships, and cases of abuse of allowances and trust (Blevins-Knabe, 2006; Klatt, 2006). Behind this lies the conviction that treating students as clients poses fewer risks.

Student-teacher interactions had a decisive role in the early models of student integration. Even the earliest findings attested to the fact that any type of formal or informal

---

<sup>4</sup> Ez a kutatás az oktató-hallgató kapcsolat mutatóiként a következőket alkalmazta: fogadóórai találkozós, informális tanácsadás, bevezető, orientáló foglalkozás és vizsgaelőkészítés (Bargel et al., 2008).

relationship with the teacher has a positive effect on students' achievement, commitment and satisfaction (Gaff&Gaff, 1981; Milem&Berger, 1997). This is often stated in the literature, however the majority of researchers only mention the significant correlation between the variables but they very rarely undertake the investigation of the operational mechanisms or a theoretical interpretation of the phenomenon. It is also very uncommon for researchers to qualify the nature of student-teacher communication.

From students' point of view teachers can exert the most influence through an intellectually stimulating relationship. Shaping teachers' and students' knowledge through disputes is one of the most outstanding and lasting specialties of higher education. The lack of relationship can also be interpreted as the manifestation of an intellectual incompetence for debates or discussions, which according to all paradigms leads to resource deficit. The mere presence and availability of teachers already has a positive effect since it creates an impression of reliability, which indicates the "strength of social capital" in a relationship (Coleman, 1988). According to Bryk and Schneider increasing trust in role partners in educational institutions contributes to improved educational outcomes (Bryk&Schneider, 2002; Pusztai, 2009). In order to achieve this, collaborators have to be assured that taking their interests into account is mutually important and that work is carried out in an honest and competent manner. Thus, student-teacher interactions also show students how committed the institution is to them.

There is a further aspect which confirms that trust in teachers goes beyond its primary significance. Departing from Simmel's theory of general trust and accepting that interpersonal trust is the basis for generalized trust, it follows that trust in teachers could advance trust in higher education. According to Lin (2005) there is no knowledge of how this generalized trust develops. We are also investigating the source of general trust which could arise from the number of trustworthy people in one's own personal network, or perhaps from the number of peers who also trust teachers (Pusztai, 2014).

In the interaction model the role of student-teacher communication is to create an opportunity for social comparison. Students can measure up their dispositions to the values and norms of the representatives of the academic environment, and they can receive information on the congruency of their own values and norms. The more contacts, the higher the level of conformity and congruency. Frequent contacts can also have anchoring results, i.e., they can correct the consequences of students drifting between identity- and value orientation (Berger&Milem, 2000). The simplified view on teachers presented in these models does not take into account the fact that similarly to students' culture teachers' culture has become pluralized giving rise to different institutional manifestations of confrontations yielding very different results.

Following to the logic of Coleman's social capital theory, the active presence of the teacher contributes to the cohesion of the institutional social network also in other ways. Encouraging performance through control is only one of the numerous effects it can have. In this respect the student integration theory again shows similarity to Coleman's social capital conception, which also claims that, the more frequent and versatile communication is, the higher the chances for academic success. Nonetheless, the social capital educational theory explains this with the mutual exchange of norms and control promoting the achievement of a greater level of performance. Thus, this theory raises not only the



question of connectivity but also the question of the embeddedness into the system of norms (Pusztai, 2015).

According to the social capital theory, apart from the frequency, it depends on the quality and versatility of communication whether resulting benefits will have an effect on students' career, especially in the case of low-status, non-traditional students (Jaeger&Eagan, 2009). Teachers' conduct is part of the institutional conduct and it can contain many features related to the unequal treatment of low-status students as identified by Bourdieu. Lower expectancy as compared to middle-class students, as well as traditional educational features favouring higher-status students: the language of education, assumed knowledge, as well as favouring style as opposed to content (Thomas, 2002). Relating to teachers in the classroom has its own rite, usually characterized by passivity and distance keeping on the students' part. Despite the transformation of higher education, the type and choreography of classes have barely changed. For a long time, the breakthrough in the modernization of higher education pedagogy was seen exclusively in the use of information and communication technology. Nonetheless, in the international literature there is a growing emphasis on the following topics: rethinking the content of higher education pedagogy, classroom atmosphere, identifying more efficient solutions for the personal advancement of students, students' participation, and investigating active and community learning (Astin, 1987).

More recently, the European literature on higher education pedagogy has been formulating expectations regarding high-school teachers. Among the inclusive higher education behaviour indicators defined on the basis of students' perceptions we find: the constructive management of the academic problems of previously underrepresented groups of students, support offered in shaping and fine-tuning academic aspirations, personal evaluation and interpretation of educational achievements, as well as expressing personal interest (calling students on their names) (Thomas, 2002; Pusztai, 2011).

The changes in the nature of teaching relate to the quality and quantity of communication with students. This has also affected the relationships within the institution and students' contribution to the benefits arising from these (Pusztai, 2011). The cost-effective increase in the teacher-student ratio, the competition against research-related activities, or part-time teachers' multiple identity significantly reduces the time spent teaching. Approaches to occupational status deal with the aspects of working hours and position within the institution. It is true that part-time teachers reduce the costs of the institution, however they are not available to students, they develop less relationships, they require less from students or have lower expectations from them, and they are less often chosen as thesis supervisors (Umbach, 2007; Jaeger&Eagan, 2009).

Teachers' time management in favour of a certain institution was always considered a source of social capital, which helps not only solve school related problems but also creates solidarity with the tasks of the institution (Bryk et al., 1992). International studies show that part-time teachers in higher education identify less with the culture and special tasks of the institution, moreover they are usually dissatisfied with the work they do (Jaeger&Eagan, 2009). Studies in our country have not dealt with this issue yet, however we have proposed an alternative hypothesis that part-time teachers can bring new information and opportunities to the institution. This however can offer results only at the highest levels of university education (Pusztai, 2009b).

One of our previous investigations has focused on the fact that there might be a connection between teachers' availability and efficiency not only on BA and MA level but also on PhD level (Pusztai, 2009b). Views differ on what kind of social networks would benefit PhD students in a successful academic career and what types of ties (weak, strong, bridge or connecting) are more influential among them. The extent to which the network of supervisors, tutors, and PhD students can have an impact also depends on the discipline and the culture of the institution. Studies show that ties extending to supervisors and teachers in the PhD programme, as well as embedding into the academic network play a significant role not only in completing the dissertation (Lovitts, 2001) but also in conveying values, norms and behaviour patterns. Weak institutional embeddedness of PhD students can forecast inefficiency in their PhD studies (Austin, 2002; Pusztai, 2011). All these emphasise the importance of workshops functioning as real academic communities, as opposed to PhD programmes involving so called "dead souls", i.e., PhD students working in isolation. While carrying out research investigating PhD programmes we found among indicators measuring integration not only indicators related to research (research group membership, joint publication, academic or professional association membership) but also such indicators as working in the same office with the teacher, or having common leisure activities, e.g. sports (Lovitts, 2001; Pusztai, 2011).

Our quantitative studies show that formal and informal institutional relationships of integration have the strongest and most stable effect on student efficiency. In order to achieve better than average results, students enrolled in higher education in the region under scrutiny by CHERD need a sufficient quantity and quality of communication with their teachers on various topics. Students need academic, scientific, intellectual and public life discourse on a regular basis and need to reflect on their future plans, personal aptitudes, sometimes even on their academic and personal problems in the light of these (Pusztai, 2011; Pusztai, 2015). Being in agreement with the teachers' worldview is also of crucial importance, especially in the case when it is not the approach advocating high performance that dominates. We have found and presented a number of such cases in the previous chapter. Students can become familiar with the teachers' worldview only through student-teacher interactions and reaching agreement is rather just a possibility in the light of the influence of the interpretive communities which have a different impact (Pusztai, 2011).

## References

- Astin, A. W. (1993). *What Matters in College: Four Critical Years Revisited*. San Francisco, CA: Jossey-Bass.
- Austin, A. E. (2002). Preparing the Next Generation of Faculty: Graduate School as Socialization to the Academic Career. *The Journal of Higher Education*, 73 (1), 94–122. doi: 10.1080/00221546.2002.11777132
- Bargel, T., Ramm, M. & Multrus, F. (2008). *Studiensituation und studentische Orientierungen. 10. Studierendensurvey an Universitäten und Fachhochschulen*. Bonn, Berlin: Bundesministerium für Bildung und Forschung.

- Bargel, T., Multrus, F., Ramm, M. & Bargel, H. (2009). BachelorStudierende. *Erfahrungen in Studium und Lehre*. Bonn-Berlin: Bundesministerium für Bildung und Forschung.
- Berger, J. B. & Milem, J. F. (2000). Organizational behavior in Higher Education and Student Outcomes. In Smart, J. C. (Ed.): *Higher Education: Handbook of Theory and Research Volume XV* (pp. 268-338). Bronx: Agathon Press.
- Blevins-Knabe, B. (2006). The ethics of dual relationships in higher education. In Barrow, R. & Keeney, P. *Academic Ethics* (pp. 457-473). London: Ashgate.
- Bonwell, C. C. & Eison, J. A. (1991): *Active learning: Creating Excitement in the Classroom*. ASHE-ERIC Higher Education Reports.
- Bourdieu, P. (1988). *Homo Academicus*. Stanford: Stanford University Press.
- Bolden, E.C., Oestreich, T., Kenney, M.J. & Yuhnke, B.T. (2017). Location, location, location: A comparison of student experience in a lecture hall to a small classroom using similar techniques. *Active Learning in Higher Education*, 20 (2) 139-152.
- Bryk, A. S., Lee, V. E. & Holland, P. B. (1992). *Catholic Schools and the Common Good*. Cambridge: Harvard University Press.
- Bryk, A. S. & Schneider, B. (2002). *Trust in Schools: a core resource for improvement*. New York: Russel Sage Foundation.
- Bryson, C. & Hand, L. (2007). The role of engagement in inspiring teaching and learning. *Innovations in Teaching and Education International*, 44 (4), 349-362. doi: 10.1080/14703290701602748
- Castro, C. de M. & Levy, D. C. (2001). Four Functions of Higher Education. *International Higher Education*, 23 (2), 5. doi: 10.6017/ihe.2001.23.6594
- Clark, B. R. (1987). *The Academic Life: Small Worlds, Different Worlds*. Princeton: The Carnegie Foundation for the Advancement of Teaching.
- Coleman, J. S. (1988). Social Capital in the Creation of the Human Capital. *American Journal of Sociology*, 94 (1), 95-120. doi: 10.1086/228943
- Gaff, J. G. & Gaff, S. S. (1981). Student-faculty relationships. In Chickering, A. W. & Associates (Eds.): *The modern American college* (pp. 642-656). San Francisco: Jossey-Bass.
- Gaskó, K. & Kálmán, O. (2014). Learning in Higher Education. In Vámos, Á. & Lénárd, S. (Eds.): *Training programme and organisation in the Bologna process of Hungarian higher education : The BaBe project* (pp. 82-98). Budapest: ELTE Eötvös Kiadó.

- Greenbank, P. & Hepworth, S. (2008). *Working Class Students and the Career Decision-making Process: a qualitative study. Report for the Higher Education Careers Service Unit (HECSU)*. Manchester: Edge Hill University.
- Harper, S. R. & Quaye, S. J. (Eds.) (2009). *Student Engagement in Higher Education*. New York-London: Routledge.
- Jaeger, A. J. & Eagan, M. K. (2009). Unintended consequences: examining the effect of part-time faculty members on associate's degree completion. *Community College Review*, 36 (3), 167-194. doi: 10.1177/0091552108327070
- Klatt, H.-J. (2006). Political correctness as an academic discipline. In Barrow, R. & Keeney, P. (Eds.): *Academic Ethics* (pp. 36- 45). London: Ashgate.
- Kozma, T. (2004). *Kié az egyetem? A felsőoktatás nevelésszociológiája*. Budapest: Új Mandátum Könyvkiadó.
- Lin, N. (2005). Social Capital. In Beckert, J. & Zagiroski, M. (Eds.): *Encyclopedia of Economic Sociology*. (pp. 604-612). London: Routledge.
- Lovitts, B. E. (2001). *Leaving the Ivory Tower: The Causes and Consequences of Departure From Doctoral Study*. Lanham: Rowman and Littlefield.
- Márkus, E. & Engler, Á. (2019). Developing and Methodology of Training Courses for Improving Competence- and Learning Outcomes. In Erdei, G., Juhász, E., Sahin, S. & Kaan, A. (Eds.): *Ways of Promoting Excellence in Higher Education* (pp. 107-123). Ankara: Pegem Akademi Yayıncılık Eğitim Danışmanlık Hizmetleri Tic. Ltd.
- Milem, J. F. & Berger, J. B. (1997). A modified model of student persistence: Exploring the relationship between Astin's theory of involvement and Tinto's theory of student departure. *Journal of College Student Development*, 38 (4), 387- 400.
- Pusztai, G. (2008). Les bienfaits pédagogiques de la religiosité parmi les élèves hongrois de trois pays, *Social Compass* 55 (4), 497-516. doi: 10.1177/0037768608097235
- Pusztai, B. (2009). Tér tudat és tudatturizmus. In Michalkó G. & Rácz T. (Eds.): *A tér vonzásában* (pp. 17-30). Székesfehérvár-Budapest: KJF MTA Földrajztudományi Kutatóintézet.
- Pusztai, G. (2009a). *A társadalmi tőke és az iskola. Kapcsolati erőforrások hatása az iskolai pályafutásra*. Budapest: Új Mandátum Könyvkiadó.
- Pusztai, G. (2009b). Mentor vagy idol? A doktorandusz-témavezető kapcsolat formái a tudományos utánpótlásképzésben. In Pusztai G. & Rébay M. (Eds.): *Kié az oktatáskutatás? Tanulmányok Kozma Tamás 70. Születésnapjára* (pp. 337-353). Debrecen: Csokonai Kiadó.

Pusztai, G. (2011). *A láthatatlan kéztől a baráti kezekig. Hallgatói értelmező közösségek a felsőoktatásban*. Budapest: Új Mandátum Könyvkiadó.

Pusztai, G. (2014). The Effects of Institutional Social Capital on Students' Success in Higher Education. *Hungarian Educational Research Journal*, 4(3), 68-83. doi: 10.14413/herj.2014.03.07

Pusztai, G. (2015). *Pathways to Success in Higher Education Rethinking the Social Capital Theory in the Light of Institutional Diversity*. Frankfurt am Main: Peter Langú.

Szczepanski, J. (1969). *A felsőoktatás szociológiája*. Budapest: Felsőoktatási Pedagógiai Kutatóközpont.

Thomas, L. (2002). Student retention in higher education: the role of institutional habitus. *Journal of Education Policy*, 17 (4), 423–442. doi: 10.1080/02680930210140257

Thomas, L. & Jones, R. (2007). *Embedding Employability in the Context of Widening Participation*. York: The Higher Education Academy.

Umbach, P. D. (2007). How effective are they? Exploring the impact of contingent faculty on undergraduate education. *The Review of Higher Education*, 30 (2), 91- 124.

## Making the change – how did we succeed? Case Innopeda

Liisa Kairisto-Mertanen<sup>1</sup>, Marjut Putkinen<sup>2</sup>,

<sup>1</sup>Technology and business, Turku University of Applied Sciences, Finland <sup>2</sup>Health care m  
Turku University of Applied Sciences, Turku, Finland

---

### **Abstract**

*During the 250 years the world has changed remarkably but in the universities we still tend to apply practices stemming from the middle ages when the first universities were established. Not only providing workforce but also having an impact on the world of work in its region is one of the important tasks of the university. Alongside with the changing working life also the requirements set for graduates have changed. This means that the ways of carrying out education must be adapted according to the changes.*

*In this paper we describe one change process which has impacted the work done in the specific university and the competences the graduates are reaching. The paper is based on a research done among all the members of one university which had a clear focus and vision about the changes needed.*

**Keywords:** Making a change; education; Innopeda.

---

## **1. Introduction**

The changing working life is often mentioned to form the biggest challenge for many nations. Already more than 30 years ago the concern for the ability of organizations to respond to environmental change was according to Kotter and Schlesinger (2008) mentioned as the most significant management issue and problem to be foreseen during the coming years. This is no wonder as during the last 250 years the society has experienced four industrial revolutions due to which the way how we work, what are the occupations and our lifestyle in general have changed remarkably. However education and the way how we teach have changed relatively less than the society in general.

The first universities were grounded in the middle ages in France and Italy and since those times many practices have remained the same when it comes to carrying out educational tasks. The change in the environment of any educational institution is enormous concerning the problems we are facing today or considering all the equipment available to help in the process of learning and teaching. Information is freely and easily accessible to everybody, the teacher is not any longer the only source of information for the students. The society surrounding any educational institution is facing great challenges due to f.ex. the sustainability crisis or aging population. New solutions are needed when tackling these

## **2. Managing the change in an educational institution**

### ***2.1 The change process***

Litterature speaks about first order and second order change. First order change concerns minor adjustments and improvements in one or several dimensions of the organization. It does not change the organizations core. Second order change is transformational and concerns the underlying values, mission and structure of the organization. (Kezar 2001.)

Monitoring the change in the environment and corresponding to it by acting as a local influencer belongs to the tasks of universities of applied sciences in Finland. This change process is adaptative meaning that the changes in the external environment modify and alter the organization when it is making the necessary adptations to follow the development in the external environment. (Kezar 2001.) Managing the task calls for tight relationship with local enterprices and other organizations as well as intensive cooperation in the fields of education, research and development. It is also a prerequisite for developing the internal processes of the university and contributes to its ability to educate students who sto the needs of the changing society.

## 2.2 Managing the change

Popovic and Plank (2016) present a three stage model for change management. Referring to Kotter's (1996) eight-stage process model of creating change they say that in the context of academic development a successful change management process includes the stages of *creating a climate for change, engaging and enabling the organization and implementing and maintaining change.*

A successful change management is most likely to succeed when there is a clearly defined aim and a desired end for it. For the change to take place a suitable climate for change should first be created in the organization. All the actions should be directed towards engaging and enabling the organization and finally measures are needed for sustaining and maintaining the change. (Kotter 1996.)

Creating a suitable climate for change in an educational institution is very much about making the needs of the surrounding society clear and visible. Being aware of the changing environment outside of the university should naturally form part of any faculty members life but painting a real life picture about the environment helps in initiating the change process. Understanding why the change must take place is an important beginning part of the change analysis and conversation (Kezar 2001).

Once the need for change is understood the next task is to engage and enable the organization. It is essential to communicate the vision and find the right people from the organization to start the change process with. Senge (1992) speaks about learning organizations and states that in the circumstances of constant change it is necessary that the whole organization is updating its competences all the time. Organization that are competent learners are called learning organizations. Senge (1992) stresses the importance of the members of an organization sharing the same vision of the organization's aspirations and future. It becomes important to have the vision embedded in the organization to ensure a continuous cycle of improvement (Popovic & Plank 2016.)

The third phase of change management includes implementing and sustaining the change. Using Senge's terminology the organizational members should achieve a situation of personal mastery and have the capacity to produce desirable results. Working with existing mental models, which are deeply ingrained assumptions or generalizations that individuals hold about the world, also becomes necessary. (Senge 1992.) It is very much possible that people with different mental models understand the same thing differently. This stresses the importance of being aware of the existing mental models and to know how to influence them to the desired direction. Knowledge generation in both individual and organizational level results from the interaction of acquired information with existing mental models. The actions taken are ultimately based on decisions made about the cause of a problem and the perceived outcomes of any actions we take to correct the problem. (Senge 1992)



## 2.3 Case Innopeda

The need for innovations is recognized everywhere in the society. Already ten years ago the working life expressed a need to get graduates who have cross-disciplinary competence.

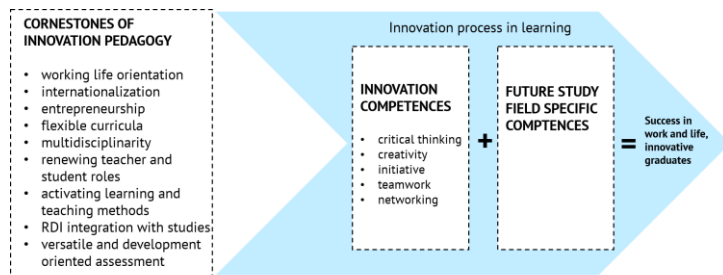

Figure 1. Innovation pedagogy in a nutshell

Innovation pedagogy can be presented according to figure 1. The aim of the educational process is to create success in work and life for the students but also for the university and for the whole society surrounding the university. The aims are reached when the innovation process in learning creates both study field specific competences as well as innovation specific competences. The definition of Innovation competences - creativity, initiative, critical thinking, teamwork and networking - is based on the results of international research projects. (Kairisto-Mertanen & all. 2011; Marin-Garcia & all. 2013; 2016). The cornestones must be found in the learning learning environment to quarentee the presense of Innopeda.

## 3. Purpose of the paper and methods used

The purpose of this paper is to reflect the change process at TUAS by presenting the views of university personnel about innovation pedagogy and how it is shown in everyday practice of the university. The data was collected using a Webropol questionnaire which was electronically mailed to the whole personnel of TUAS. The questionnaire consisted of 5 open questions aimed at exploring the attitude towards innovation pedagogy and how it is shown in the everyday work of the respondents.

Because of the organizational change taking place at the same time at TUAS the researchers did not get the permission to personally collect the answers or motivate the respondents. This had to be left to the new management. All this resulted in altogether 148 returned questionnaires representing a response reate of 20 %. 116 of the responses came from teaching staff, est of the responses stemming from other personnel groups. The responses were analyzed in one gategory using the Webropol tools. Using subcategories was not possible due to the small amount of respnsses. Innovation pedagogy represents the organizational culture of TUAS which supports keeping also the nonteaching staff members in the analysis.

#### **4. The change process at TUAS**

Innovation pedagogy was mentioned for the first time around year 2008 at the same time Finland's innovation strategy was launched year 2008 and it put great responsibility to the universities of applied sciences in creating innovations. It took some years until Innovation pedagogy was officially included in the strategy of the university indicating that it should form the educational approach followed by every member of the organization. During the path many obstacles were met and neither faculty members, other staff nor students were eager to accept the new approach without questioning. However the organizational structures at TUAS support implementing a multidisciplinary approach in learning and teaching. The cross-disciplinary educational units make it possible for the students to meet students from many different degree programs.

The change from teacher centric way of operation to student centered culture is a must when aiming at producing innovation competences. Making the change happen has required developing the management of the university and finding new forms of cooperation between faculty and students. It has also been necessary to motivate the faculty to continuous learning and rethinking of their present ways of delivering education. (Kettunen & all. 2013; Konst & Kairisto-Mertanen, 2018).

All the phases of the change process presented by Popovic and Plank (2016) can be found in the process we have undergone at TUAS. It has proven to be extremely important to first create a climate for change by presenting reliable proof about the necessity. During that phase we made many mistakes as we took it for granted that the need for change is understood if enough proof is presented.

Engaging and enabling the organization was done by organizing numerous events where people were provided a chance to get to know each other as there can be no cooperation without knowing the people to cooperate with. During these events we shared knowledge about good practices and developed new ideas together. In the beginning people had many prejudices but along the years trust was gradually born. An important step in imbedding innovation pedagogy in the everyday work at the university was the development of an internal training program meant for every member of the staff.

An important step in maintaining the change was that innovation pedagogy was the implementation of innovation pedagogy in the strategy of the university. At the moment it is considered as a concept which all the personnel at TUAS is developing together.

## 5. How did we succeed

### 5.1 The Cornerstones of innovation pedagogy in practice

The cornerstones of innovation pedagogy are essential tools when putting it into practice. For innovation competences to be born in the learning environments is essential. Those students who have studied more according to the environments defined in the cornerstones have developed their innovation competences more than other students. The methods used in learning, flexible study plan, internationalization, multidisciplinary and workinglife orientation seem to be especially important. (Keinänen & Kairisto-Mertanen, 2019.)

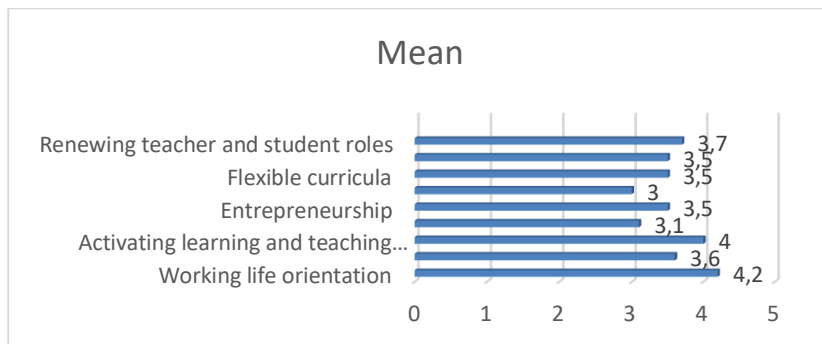

Figure 2. The cornerstones in everyday work

As can be seen from figure 2 the university personnel reports applying the cornerstones quite well in their everyday work. Biggest means are for working life orientation and for activating learning and teaching methods. The smallest means are for entrepreneurship and RDI integration with studies. Based on these results it can be concluded that working life oriented and activating learning and teaching methods are in wide use at TUAS.

The responses also show that the learning environments at TUAS are reported as multidisciplinary and international. The assessment methods are reported as versatile and the student and teaching roles are renewing. Entrepreneurships and RDI integration with studies are reported as least applied cornerstones. This might be due to the fact that implementing them is more difficult than implementing other cornerstones.

### 5.2 Understanding of Innovation pedagogy at TUAS

The research also aimed at forming a picture about how TUAS personnel understand Innovation pedagogy. The obtained 147 responses were analyzed with the textmining tool in Webrobol software.

Examining the words in the responses shows a connection between the students and the working life and cooperation between both. Very often the discourse among teachers moves

around teaching although learning is the concept who really should be interested in. Teaching describes the work of a teacher but learning is the process of the student and it must happen at all levels of education. The research shows that learning is put at the center concerning ideas about innovation pedagogy.

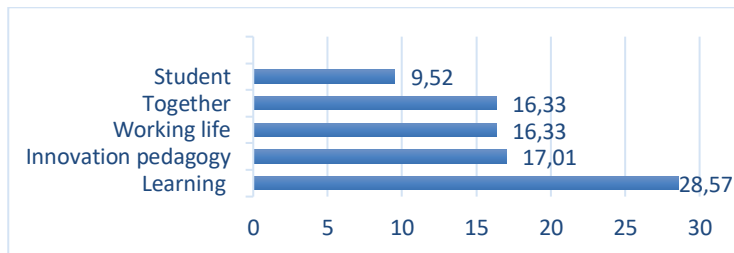

Figure 3. The most common words connected to innovation pedagogy

As table 3 presents the most common words in the responses were in addition to the word “innovation pedagogy” the words “working life”, “learning”, “together” and “student”. These answers can be interpreted to reflect understanding about student centered learning which happens together with working life. Learning in its different forms is represented in 30 % of the answers. Words “working life” and “together” which can be interpreted to represent cooperation with working life are represented in 30 % of the responses.

In the open ended questions the respondents provided several good definitions of innovation pedagogy, f.ex. *“Developing student’s (and mine as a teacher) innovation competences starting from the needs of the working life by using student centered learning methods”*.

### 5.3 Innovation pedagogy at the everyday work of the university

The respondents were also presented a question concerning how innovation pedagogy is shown in his/her everyday work. The 146 responses reflect the most common words associated with the teacher everyday work. According to figure The most common word is “student” in its different forms, 34,6 % of the responses, which reflects the central of the student in Innovation pedagogy. The next common words are “teaching, 10,3%”, “practice, 9,6 %”, “different, 9,6 %” and “more 8,9 %”.

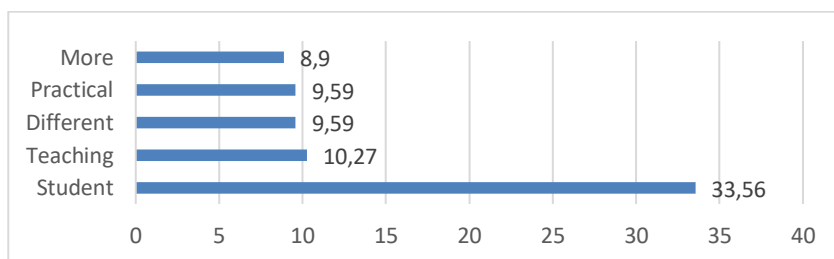

*Figure 4. The most common words reflecting teacher's everyday work*

The word charts reflect student work by connecting words “learning”, “practice”, “projects” and “more” closely together. This can be interpreted to reflect that innovation pedagogy is a widely accepted approach in the everyday work of the university.

## **6. Conclusion**

Making the change in educational institution has not been an easy process. It has required several years to actually make the change but according to the results of the research made among the personnel of the university we are following the right track at TUAS.

Universities are facing many challenges at the moment; at the same time they should be able to keep their competing position, develop their learning methods, create high quality scientific research and reduce costs. New approaches to university pedagogy are urgently needed. This example from Turku University of Applied Sciences provides one approach to tackle the challenges. It shows that a change is not very rapid but it is possible and achievable when the right measures are found.

## **References**

- Popovic, C. & Plank, K. (2016) *Managing and Leading change. Models and Practices in* Baume, D. & Popovic, C. (2016) *Advancing Practice in Academic Development*. Routledge.
- Kotter, J. P. (2012) *Leading Change*. Harvard Business Review Press. USA.
- J. P. Kotter & L. A. Schlesinger (2008) *Choosing strategies for change*. Harvard Business Review, July – August, <https://hbr.org/2008/07/choosing-strategies-for-change>
- Kezar A. (2001) *Understanding and Facilitating Organizational Change in the 21st Century*. ASHE-ERIC Higher Educational Report, Vol. 28, 4. San Francisco, California.
- Senge, P. M. (1992) *The Fifth Discipline: The Art & Practice of the Learning Organization*. Random House Australia: Milson Point, NSW.
- Kettunen, J., Kairisto-Mertanen, L., & Penttilä, T. (2013). *Innovation pedagogy and desired learning outcomes in higher education*. *On the Horizon*, 21(4), 333-342.
- Keinänen M., Kairisto-Mertanen L, (2019) "Researching learning environments and students' innovation competences", *Education + Training*, Vol. 61 Issue: 1, pp.17-30, <https://doi.org/10.1108/ET-03-2018-0064>
- Konst, T., & Kairisto-Mertanen, L. (2018). *Innovation Pedagogy: preparing Higher Education Institutions for Future Challenges*. Course Material from Turku University of applied sciences 115. Tampere: Suomen Yliopistopaino, Juvenes Print Oy.
- Marin-Garcia, J., Pérez-Peñalver, J., & Watts, F. (2013). *How to assess innovation competence in services: The case of university students*. *Dirección y Organización*, 50, 48–62.

## How to introduce research into university teaching: A training experience in the Universitat Politècnica de València

Amparo Fernández March<sup>1</sup>, Eloina García Félix<sup>1</sup>, Amparo García Carbonell<sup>2</sup>, José V. Benlloch-Dualde<sup>3</sup>, Pilar Bonet Espinosa<sup>1</sup>, Javier Oliver Villarroya<sup>4</sup>

<sup>1</sup>Institute of Education Sciences, Universitat Politècnica de València (UPV), Spain, <sup>2</sup>Dept. of Applied Linguistics, UPV, <sup>3</sup>Computer Engineering Dept., UPV, <sup>4</sup>Dept. of Computer Systems and Computation, UPV, Spain.

---

### **Abstract**

*In this work we present the project of initiation to the Educational Research-Action (INED), within the pedagogical training program for university teachers organized by the Institute of Education Sciences (ICE), of the Universitat Politècnica de València (UPV). This project responds to a need for a group of teachers that starts with a professional background and requires training to advance the process of professionalization of teaching, aligned with the concept of scholarship and the movement generated around it.*

*The proposal is formulated as an action research to promote the improvement of teacher training models in higher education. Therefore, it involves a methodology close to the learning communities, so that both the design and implementation involve professors from the university with a background in educational research (6 mentors), pedagogical advisors and experts in different subject areas related to research in higher education.*

*In this first edition of INED, 25 professors participate and have been selected according to criteria of teaching experience, participation in educational innovation projects and pedagogical training received in different formats.*

**Keywords:** *Educational innovation; action research; research methodologies; pedagogical training; teacher training.*

---

## **1. Introduction**

The Institute of Education Sciences (ICE) of the Universitat Politècnica de València (UPV) has launched an *Initiation Program for Research-Educational Action* (INED), aimed at university professors with a certain academic background.

The trajectory of the ICE in supporting the educational development of the UPV is extensive in time and in the variety of actions that have been carried out and are currently carried out. However, the analysis of the effects of some of the actions, both in the change of teachers' conceptions in relation to the meaning of teaching-learning and in the impact on the students' own learning, place us before a new problem to which we intend to respond. Therefore, we propose an action research project on this issue. The questions on which we pivot this investigation are the following:

How can we redirect some of our actions to align them with a renewed vision of the meaning of "being a good teacher" in the university field? And more specifically:

Can a training action accompany experienced teachers, with a certain background in educational innovation, in the process of addressing a profile of "professor-researcher" on their own teaching?

- What type of program design would be the most appropriate?
- Who should we count on to be able to address it effectively?
- Will the program change the personal conceptions of the participants regarding teaching and learning?
- Will this change have an impact on teachers' educational practices? And in the teaching culture of the UPV?

### ***1.1. Diagnosis of the situation: documentation on the subject***

The progress of the approaches on the training of university teachers depends, to a large extent, on the perspective with which it is faced. There is no doubt that the proposed changes are not solved with the design of training programs that are tried to be implemented expeditiously. As any process of change or innovation belongs to the category of social and political issues, resistant to rationality (Escudero, 1999).

Therefore, facing pedagogical training, from this perspective, means admitting that the most decisive thing is not the type of program or strategy that we must design, but what changes must occur in the structure of values and feelings that weave the identity of the university professor. That the teacher is able to recognize other content and purposes, as well as other types of recognition, that accommodate their professional development and are accepted by the university community. And all this without forgetting that the logic of individual needs, that is, that which arises from practice and is linked to the teaching staff's

vision, must be combined with the logic of institutional needs. That is, with the challenges that the University, as an institution dedicated to Higher Education, has raised at the present time, and that are translated into true challenges to which the university will necessarily have to respond (Fernández, 2003).

When the differences between a professional and an "amateur" are established, it is affirmed that the professional gathers the competences of the creator and the executor, that is, knows how to isolate the problem, poses it, looks for a solution and executes it. All this would be impossible without broad knowledge, academic and specialized knowledge, which never starts from a fresh start. However, despite having resources, the situations that professionals face are always complex, that is, they have something unique, so they always require an adjustment between the prescribed and actual work. If this is true for all professions, in those that deal with the human being, as is the case with education, the prescribable part represents a smaller proportion and a higher qualification is essential. The teacher has to assume high levels of responsibility and an autonomy of action in their decisions and actions would be necessary.

This analysis perspective is what leads us to state that in the design of the university teacher training plans, certain reference frameworks that give congruence and meaning to these plans and that connect with the University's strategic policy in relation to teaching quality are necessary.

Thus, the research project that we present has the purpose of generating a path of professional training for university professors who want to continue developing in the teaching field. In this sense, to base their research project we rely mainly on three aspects:

### ***1.1.1 The Teaching Academic Development Framework (TADF)***

The *Red Estatal de Docencia Universitaria* (REDU) committed to the project of developing a framework for teacher qualification for the professional development of university teachers, now approximately two years ago. The first conversations and exchanges were with British experts who had participated in the development and application of the UKPSF (The UK Professional Standards Framework, 2011). After various preparatory conferences and seminars, REDU decided that it was really worth trying to set up a specific framework for Spanish universities and propose it to the university community.

A framework for teacher qualification, whether it is the UK Professional Standards Framework or our proposal for a professional teacher development framework, is always a shared and grounded vision of what it means to be a good teacher and how to move towards there.

A simple vision of the teaching quality, limited to the fulfillment with the classes, the ability to explain well an updated knowledge and the kind answer to the questions of the



students, requires little of the universities, of the teaching staff or of the educational authorities. From an institutional point of view, if we conceive teaching like this, it is not worth too much effort in teacher training, teacher innovation, teacher evaluation or recognition of teacher quality. It will be enough to ensure sufficient academic quality and to go through some particularly problematic cases of non-compliance or dissatisfaction of students. From the perspective of the teaching staff, a teaching thus conceived is not problematic, beyond finding the necessary time to select and organize the contents of the program and prepare some resources that facilitate its understanding.

From this perspective, it is not well understood to invest too many resources in teacher training or innovation programs, justified simply to the extent that they can provide some technical improvements or practical resources, nothing that makes a big difference. And, from the point of view of the system as a whole, of its policies and evaluations of quality or of the accreditation of its teaching staff, if the educational quality is something so affordable, there is not much to recognize or to promote: why would we have to recognize something as simple when we have much more complex and meritorious challenges such as research.

On the contrary, a vision of advanced and complex teaching, based on the state of the art of research on the factors and practices that make a difference in student learning, sets up a very different picture. It reveals, first, that a great diversity of factors converge in good teaching, many of which require a great deal of knowledge, preparation and experience. It also reveals that achieving a high degree of professionalism and teaching quality is a progressive and long journey, virtually infinite (Paricio, Fernández & Fernández, 2019).

### ***1.1.2 The theoretical construct of scholarship (research, training ...) and its crystallization in SoTL***

The relationships between research and teaching are usually complex and unfriendly. The idea that the important thing is to investigate and that teaching is a second level activity for which it is only necessary to master the discipline are widespread. It is usual, therefore, to find teachers who act by intuition, reproducing the guidelines that they have observed in their own teachers and that does not take into account the results of research on teaching and learning in Higher Education when it comes to teaching. Somehow the teaching is developed in a sort of naive amateurism and grows outside the academic world with capital letters.

This predominant pattern is clearly changing in Anglophone countries where "academic being" is acquiring a more diverse and versatile meaning, through networks, societies and scientific journals that are oriented towards the Scholarship of Teaching and Learning (SoTL).

The SoTL is a renewed conception of what it means to be an academic and has its origin in the report *Scholarship Reconsidered: Priorities of the Professoriate* (1990) published by Boyer in 1990 at the Carnegie Foundation for the Advancement of Teaching.

Although there is no agreement between researchers to accept a definition of SoTL that is accepted by the scientific community, it can be considered as the most accepted proposal of definition by Shulman (2000): “For an activity to be designated as a scholarship it must manifest at least three characteristics: be public, susceptible to critical review and evaluation, and accessible for exchange and use by other members of the academic community”.

Since the early 1990s, this concept has attracted the attention of many researchers in the area of professional teacher development, especially in higher education. SoTL is presented as a model for their professional development and their position towards teaching and learning, which aims to revalue and equate both functions, the teacher and the researcher.

Thus, it can be stated that the SoTL has three objectives: i) to improve the quality of training and student learning; ii) to recognize and value the pedagogical effort; and iii) to propose a professional development framework.

Being a “SCHOLAR” means doing an excellent job and being able to help or guide colleagues towards excellence. In research an academic progresses in his career towards the expert level. SoTL is a frame of reference that affirms that a teacher can (and should) progress until reaching the level of academic in the field of teaching in the same way as he would in the investigation of his disciplinary field. This idea is embodied in actions such as the following:

- Reflect on their teaching, justify the fundamentals of pedagogical resources, get involved in educational innovation, evaluate their teaching to improve it.
- Discuss with colleagues about pedagogical issues, assume responsibilities, incorporate their innovations into their quality process ...
- Publish and make presentations related to their teaching, obtain funds to carry out research on their teaching, help colleagues to train ...

### ***1.1.3 Design of teacher professional development programs with the greatest potential impact on educational practice***

The involvement of teachers in action research projects is one of the professional development strategies that best fits the purpose of transforming conceptions and beliefs about teaching and learning and overcoming intrinsic barriers in innovation and improvement processes. The structured and systematic inquiry into the practice itself allows to merge training, research and educational action. In this way, the transformation of the practice is no longer a potential effect of the training, but the very object of a research

process that begins and ends in that same practice and that results in a transformation of both the practice and the educational conceptions of the teachers involved.

The rigor of the method, with its planning, action, observation and reflection phases, allows the construction of practical knowledge that constitutes the very essence of teaching professionalism. That is, the problem of the dissociation between theoretical training (received from the outside) and educational practice (generated from the inside) is solved here with the generation of an own and contextualized knowledge. The diagnosis, the hypothesis-action or the evaluation / final reflection, key moments of the method, demand an intense dialogue between the educational theory and the specific situation. The result is the construction of an own and situated knowledge that is directly linked to the practice and the progressive transformation of that practice.

The improvement of the impact of its activity lies in finding solutions to this double requirement that the teaching professional development of the teaching staff be constructed from reflection and research on their own teaching practice and context and that this effort is framed within a led institutional strategy from the highest levels of command.

Next, we set out the objectives and hypotheses of the action, as well as the planned actions and the observation of the action itself. The training program is detailed, as well as the strategies and evidence for the collection and analysis of data from the research itself.

## **2. Objectives**

The objectives proposed by the research are specified in the following:

- To experience an innovative training proposal for university teachers in our educational context.
- To generate a learning community with professors and specialists in university pedagogy through a peer learning methodology that learn and lead the training project.
- To analyze previous conceptions about learning and teaching processes in order to move towards conceptions in which the focus is quality learning.
- To establish a professional development path for university professors in accordance with the Scholarship model.

Of these objectives, we propose two hypotheses: i) teachers participating in the training program that follow the training and advisory guidelines established in the program will acquire skills and knowledge to carry out “adequate” educational research and ii) the training model responds to the training needs of university teachers that can be found at level two and three of the TADF.

### **3. Methodology**

This new training proposal is oriented to the development of research projects with themes aligned with the most relevant factors of the quality of university learning. It has been designed to be carried out in three phases:

- Phase I. Initiation to the research process.
- Phase II. Design or redesign of the research project and research protocol publication.
- Phase III. Development and dissemination of research.

In order to ensure and optimize the quality of the program, requirements for access to the program and basic commitments have been established both by the participants and the mentors: i) to be participating or having participated in an Educational Innovation and Improvement Project (PIME) or / and Educational Innovation and Quality Team (EICE) during the last three years (4 points out of 10); ii) to prove a teaching experience of at least 5 years (1 point out of 10); iii) to prove participation in ICE training programs (1.5 points out of 10); iv) formal commitment to the conditions of the program (apprenticeship contract) (1.5 points out of 10); and v) interview (2 points out of 10).

Taking these requirements into account, a total of 28 participants have been selected, who have a series of commitments to the program:

- Attend and actively participate in the training activities that arise.
- Design an educational research or action research. If you have an educational innovation in process, you can redirect it towards research.
- Participate in follow-up meetings convened by UPV mentors.
- Follow the mentors' guidance and recommendations throughout the entire process (design, development, evaluation and dissemination).
- Prepare a scientific article on the research carried out with the objective that it can be published in high-impact journals.

On the other hand, being a long-term training, in action, which aims to support the transit process towards a vision of the more developed teaching profession, there are also some commitments from the mentors. Therefore, there are two types of mentoring:

1. Advice by the trainers in the thematic areas that will be addressed in the training.
2. Personal advice: each participant will be assigned an ICE tutor and a UPV teacher linked to educational research in the same area of knowledge. The advice will be at the individual and group level, since subgroups of work will be created, formed by four or five teachers, related to educational research issues and concerns.

Both tutors (UPV faculty and ICE advisors) will accompany the participants throughout the training process. Finally, those who have regularly followed the entire training process and

have prepared the research article with sufficient quality level to be published in high-impact journals, will obtain recognition of 5 ECTS from ICE.

The detailed program of this training action is presented below in Tables 1 and 2:

**Table 1. Planning of training activities of the INED program (I and II phases)**

I: Initiation to the investigation process ( <i>January to March 2018</i> )			
Training Modules	Thematic areas	Modality	Strategy
	Where, how and when to publish about educational research?	Round table (3 hours)	Valuation day report
	The focus of research on higher education	Workshop (4 hours)	My research focus. Intra-group debate
II: Research design and research protocol publication ( <i>March to July 2018</i> )			
Training Modules	Design of educational research projects in the classroom	Workshop (9 hours)	Guided work. Autonomous work: DAFO
	Data analysis methodologies: quantitative	Workshop (8 hours)	Rating Sheet
	Data analysis methodologies: qualitative	Workshop (8 hours)	Description of the data collection and analysis process in the draft project
Educational Research Project	Objectives	Modality	Follow up
	Design / redesign the educational research project.  Develop a protocol according to the format that will be provided for publication.	Personal and / or small group work, with mentor supervision	Personal tutoring: mentoring supervision.  Joint session: share design protocols  Monitoring “We learn among equals”: project development and resolution of doubts  Virtual forums

**Table 2. Planning of training activities of the INED program (III phase)**

III: Research development and dissemination ( <i>September 2018 to May 2019</i> )				
Training Module	Thematic areas		Modality	Strategies
	Dissemination of the results of educational research		Workshop (4 hours)	Autonomous work Tutorials
	“Challenges of educational research”		Lecture (4 hours)	Debate Personal assessment
Educational Research Project	Objective	Modality	Follow up	
	Prepare the article for later publication	Personal and / or small group work	Personal tutoring: supervision of mentors Follow-up session	

#### 4. Results and conclusions

The program is currently in the final phase of execution. The participating professors have already carried out their field work and have collected the data and evidence that allow them to rigorously analyze what happened and to draw conclusions. After this process will come the writing of their work in scientific article format. This is the ultimate goal of the program and we assume that not all participants will have a final product of sufficient quality to be sent to periodical publications of a certain level. However, the most important thing is to have been able to involve them in a systematic and rigorous process of action research on the learning and teaching of their subjects and achieve a change of conceptions about teaching. Participants in the program move towards more complex conceptions and more aligned with what research in higher education suggests.

Below, we summarize some of the most relevant results so far.

The focus of interest in relation to participants research was focused on the following topics:

- Evaluation to learn: means of assessment, instruments (rubrics)
- Methodologies that favor active, deep learning, which pose an intellectual challenge
- Impact of ICT in learning skills
- Curriculum design of the soft skill "learn to learn" throughout the training
- Study of the quality of learning environments:
  - Participatory tools

- Resources for learning
- Social networks
- Virtual environments
- Studies on motivation to learn (deep learning vs. superficial learning)
- Peer interaction and cooperation

Clarifying what the participating professors wanted to investigate and how they were going to do it has been one of the critical process points. They have had difficulties, on the one hand, in specifying the research question and, on the other, in the review of the related literature and in the understanding of the research object we face when we talk about education.

Here are some examples of the research questions / objectives:

- Perception of the utility (task value) of a subject improves involvement.
- How can we assess teamwork competence through the realization of a Project Management Plan?
- Peer instruction and involvement.
- Do motivated students get better results?
- Is the combination of screencast and its evaluation an effective methodology to train ethical reflection?
- Can the use of Cloud Computing technologies facilitate students' self-regulation to improve the degree of achievement of learning objectives in Digital Systems Design?
- Determine the extent to which the activities described contribute to raise awareness / awareness of the challenges posed by the 2030 Agenda and to generate students more involved and committed to the learning objectives and specific results of the subjects.
- Does the methodology of critical analysis of texts performed individually and contrasted in small groups improve the ability of critical thinking of students? Does it also improve students' self-perception about their ability in this competition?
- The ApS is a methodology that allows the integration of second language learning into ICT training environments: case study.

The analysis of the research protocols allows us to draw some conclusions about how the participants have evolved. The first conclusion is that, in some cases, theoretical frameworks reflect a good conceptualization of the problem they want to study and have found good support in the scientific literature, which will allow their results to be compared with the theory that supports them. and with similar research. Second, they have been able to present various validated instruments, which will undoubtedly result in a greater consistency of their research. Third, in the methodological proposals there are some problems to isolate variables, some lack of knowledge of the most appropriate techniques for their analysis and fear of also incorporating a more qualitative perspective in their work.

A third piece of information we present refers to the result of a working session with the participants in which they were asked to reflect on the opportunities and barriers that the program was posing for them. This activity was done first individually and then in a group.

Next, we present the most relevant.

Stronger barriers: Lack of time, lack of recognition (Departments, colleagues, among other).

Less strong barriers: Lack of guidance, measuring instruments, data analysis.

Facilitators: Personal satisfaction, INED (training, accompaniment, sharing, among other), personal motivation (usefulness, learning, improvement of teaching), participating in Innovation Projects or Teams.

## References

- Boyer, E. L. (1990). *Scholarship reconsidered: Priorities of the Professoriate*. Special Report, Carnegie Foundation for the Advancement of Teaching. New York: Jossey-Bass.
- Escudero, J. M. (1999). La formación permanente del profesorado universitario: cultura, política y procesos. *Revista Interuniversitaria de Formación del Profesorado*, 34, 133-157.
- Fernández, A. (2003) Formación pedagógica y desarrollo profesional de los profesores de universidad: análisis de las diferentes estrategias. *Revista de Educación*, 331, 171-211.
- Paricio, J., Fernández, A., & Fernández, I. (Eds.) (2019). *Cartografía de la buena docencia universitaria. Un marco para el desarrollo del profesorado basado en la investigación*. Narcea.
- Shulman, L. (2000). From Minsk To Pinsk: Why A Scholarship of Teaching and Learning? *Journal of the Scholarship of Teaching and Learning*, 1(1), 48-53. Retrieved July 2, 2019 from <https://scholarworks.iu.edu/journals/index.php/josot/article/view/1582>
- The UK Professional Standards Framework. For teaching and supporting learning in higher education (2011). Retrieved July 2, 2019 from [https://www.heacademy.ac.uk/system/files/downloads/uk\\_professional\\_standards\\_framework.pdf](https://www.heacademy.ac.uk/system/files/downloads/uk_professional_standards_framework.pdf)



## Global challenges, local impact

**Ilse Schröder<sup>1</sup>, Ed de Jonge<sup>2</sup>, Erik Mooij<sup>3</sup>, Frank Evers<sup>4</sup>**

<sup>1</sup>Archimedes Institute for Education, HU University of Applied Sciences Utrecht, The Netherlands <sup>2</sup> Institute for Social Work, HU University of Applied Sciences Utrecht, The Netherlands, <sup>3</sup> Institute for Media, HU University of Applied Sciences Utrecht, The Netherlands, <sup>4</sup> Perfect Storm, The Netherlands

---

### **Abstract**

*In 2015, the UN set 17 global goals, the so-called Sustainable Development Goals (SDGs) for the year 2030, “a universal call to action to end poverty, protect the planet and ensure that all people enjoy peace and prosperity”. Although these challenges are global, their impact manifests itself on a local level.*

*An inspiring challenge for HU UAS Utrecht is to educate self-confident (upcoming) professionals who contribute to the realization of these global goals by creating local impact. In our opinion such professionals are socially involved, cope with complexity, think systemic and work trans-disciplinary. Furthermore, they ‘mix and match’ personal, societal and professional development, which will not be confined to formal education but lasts a lifetime.*

*This complex challenge forges us to transform our thinking about education and how to organize learning, and about how, where and with whom we educate. UAS’s will have to cooperate with private, public and research partners and create communities in which all participants work, learn and develop themselves while facing new challenges.*

**Keywords:** *SDG; social impact; personal development; complexity; challenge based learning*

---

## **1. Introduction**

HU UAS Utrecht (HU) aspires to contribute to an open, just and sustainable society and has committed itself to the Sustainable Development Goals of the United Nations (UN, 2015) while focusing on the quality of living (together) in an urban environment. Quite recently HU has stated her ambitions for 2026 (HU, 2019), emphasizing it's role in solving complex (mission driven) challenges. HU will take the lead in cocreating local impact concerning complex and transdisciplinary global challenges.

The labor market increasingly demands Jacks of all trades, professionals who are critical, inquisitive, innovative, entrepreneurial, and cooperative with an inclusive and international orientation. Future education encompasses development as a professional as well as a person and a citizen, able to tackle society's complex challenges.

## **2. The need for local impact and the role of UAS's**

At present, most of higher education is discipline- or domain oriented. Complex societal challenges however encompass a multitude of interconnected aspects touching upon several domains and therefore require an integrated approach of diverse perspectives, for instance environmental, economical, technical, social and juridical. In such cases a multidisciplinary approach will not suffice; an interdisciplinary or even a transdisciplinary approach is required.

In a transdisciplinary approach, different disciplines, meanings and aspects are involved on the basis of equality in initiating, designing and creating sustainable solutions for complex challenges. In fact, the different disciplines need each other for a broader view on the issue and the emergence of crossovers to new ideas. Transdisciplinarity means extending the cooperation. To create impact, not only scientists but also other social actors are involved in the process, like users, clients, special interest groups. The primacy of knowledge and solutions is no longer solely with the experts and co-design and co-creation are required.

Transdisciplinarity increases the chance that the results will actually be used. Without interaction with all stakeholders, without co-design and co-creation, it is pie in the sky and it provides too often only reports and papers. (Bunders and Regeer, 2009).

Thompson Klein expresses transdisciplinarity as follows:

“Transdisciplinarity transcends disciplinary worldviews through

1. More comprehensive frameworks and/ or
2. problem-oriented research that crosses boundaries of academic disciplines and the public and private spheres.

Major examples of the first connotation—new synthetic frameworks—include general systems theory, sustainability and new, broader paradigms for health and wellness.

In the second connotation, mutual learning, joint work, and knowledge integration are key to solving “real-world” problems.” (Thompson Klein, 2014)

Transdisciplinarity does not arise automatically. Cross-discipline and cross-domain frameworks, concepts and collaboration are available but will further have to be developed. Social questions to generate impact on complex challenges are becoming increasingly evident. So, while working on SDG’s and complex challenges derived from them, frameworks, concepts, models, methods and cooperation have to be developed together with all stakeholders. This implies that education, applying other (new) didactics, is moving more and more from campus to practice and is pre-eminently a task for UAS’s.

UAS’s have are in a unique position to contribute to solving these issues with their applied approach to research and their strong ties to the (professional) community. Yet two important and inspiring challenges for HU result from this. The first challenge is how to educate transdisciplinary working (upcoming) professionals who contribute to the society’s challenges and make local impact. The second challenge is to transform our thinking about education and how to organize learning.

We shall discuss both.

### **3. Impact makers: a whole-person approach to education**

To cope with the first challenge, to educate transdisciplinary working (upcoming) professionals who contribute to the Sustainable Development Goals and make local impact, UAS’s have to reach beyond disciplines and work across boundaries in guiding and coaching transdisciplinary innovation professionals.

Enninga (Enninga, 2018), in her research on innovation project leaders, states that the innovation process is a non-linear process and messier than a sequence of stages. The innovation project leader has to lead during the innovation journey four intertwined processes: developing the content process, stimulating the creative process, guiding the group

dynamics process, and managing the project constraints process. The innovation project leaders in her study experienced the biggest tension from the number of issues that were important at the same moment in time, the contradictions in and between these issues, the psychological contradictions between rational issues at one hand and emotional issues at the other, between long term and short term issues, between thinking creatively and divergently in one issue, while at the same time convergent, tight steering in another issue, the unexpected events, the differences in perspectives and the changes in perspectives from people and groups involved, under the experienced pressure of time, and over a longer time.

An inspiring challenge will be to educate such self-confident (upcoming) professionals who contribute to tackling the complex challenges in such a dynamic environment, and create local impact. In their training and in their work, these (upcoming) professionals will have to 'mix and match' personal, societal and professional development, which will not be confined to formal education but will last a lifetime.

Facilitating personal development can be based on the metaphor of life as a narrative biographical quest. Personal leadership is encouraged by stimulating a sense of origin, presence, belonging and destiny and by constantly facing new personal challenges. Education is enriched by elements related to for instance life orientation, spirituality, philosophy, arts, culture, sports, nature, health.

From a personal perspective, he (or she) works during the course on developing in-depth insight into his dreams, ideals, strengths, weaknesses, possibilities and impossibilities. Introspection helps him to examine them. He makes his own decisions to extend his possibilities. He tries out and evaluate (new) behavior. He deepens insight in what prevents him (inside and out) from achieving his dreams and learn to cope with that.

From a professional perspective, the (upcoming) professional will roughly delve into the specific complex social issues based on a systemic approach and the underlying disciplines. He or she is working on social challenges together with others and he takes different roles in creating impact, using insights from system theory and design-driven innovations, underlying disciplines are used.

From a societal perspective, it is about the development to active participants in society. He takes responsibility for society and his own living environment He focus on the way in which groups and people in society with different views arrive at answers and solutions. He develops his own vision on society and people and the shaping thereof in his own decisions and actions.

Professional, personal and societal development intertwine, which makes a whole-person approach to education necessary. No two professionals are the same, every development has a personal character. Different development paths can influence each other in different ways, and thus require a very personalized learning trajectory.

#### **4. New partnerships for future challenges**

Transdisciplinarity and a personalized, whole-person approach to learning require a different way of organizing learning. It requires learning spaces where professionals from different disciplines, organizations and levels of expertise work and learn. These learning communities demand new partnerships and a more open organization from UAS's, where diverse stakeholders collaborate, more intensively and on an equal basis, aimed at a clear common goal.

Within these learning communities, we apply challenge based education as an open-ended approach to tackling societal issues, where

- Challenges here are local reflections of complex global challenges,
- for which a cross-domain, transdisciplinary approach is necessary,
- and where learning is mostly self-directed.

Challenging complex global challenges in an uncertain world forces us to transform our thinking about learning and its organisation. We will have to cooperate with private, public and research partners and create learning communities in which all participants work, learn and investigate, developing themselves professionally and personally while constantly facing new challenges.

#### **References**

- Van Vugt, M., Hogan, R., & Kaiser, R. B. (2008). Leadership, followership, and evolution: Some lessons from the past. *American Psychologist*, 63(3), 182-196. doi: 10.1037/0003-066X.63.3.182.
- Enninga, T (2018). *Armchair Travelling the innovation journey Building a narrative repertoire of the experiences of innovation project leaders*. <https://doi.org/10.4233/uuid:80f3d825-cb17-4783-b43e9aa1156d847d>

Bunders, J. and Regeer, B. (2009). *Knowledge Co-creation: Interaction Between Science and Society*. The Hague: RMNO.

Thompson Klein, J (2014). Communication and Collaboration in Interdisciplinary Research  
In: *Enhancing Communication & Collaboration in Interdisciplinary Research*.  
Book. By: Julie Thompson Klein Edited by: Michael O'Rourke, Stephen Crowley,  
Sanford D. Eigenbrode & J. D. Wulfhorst

## “Design for All” in Architectural Heritage conservation: the technology challenge

Vicente López-Mateu<sup>1</sup>, Teresa M. Pellicer<sup>2</sup>

<sup>1</sup>Department of Architectural Construction, Universitat Politècnica de València, Spain,

<sup>2</sup>Department of Construction Engineering, Universitat Politècnica de València, Spain.

---

### **Abstract**

*Among the United Nations 2030 objectives for the sustainable development, stand out those who seek social, economic and cultural equality of people, within the framework of different human settlements, their cultural heritage and the natural environment. This idea raises the need to establish effective strategies, resources and tools aimed to balance the current conditions in most disadvantaged groups, such as people with disabilities.*

*The situation is complicated because the barriers to integration and inclusivity are diverse, the initiatives, legislation and ways of acting are also very different. Therefore, overcoming the situation requires a broad multidisciplinary approach. On the other hand, Heritage resources can be a valuable mean for permanent and sustainable development, if there is a proper combination of different aspects: design, management and maintenance, continuous improvement and dissemination with inclusive criteria.*

*One of the possibilities to afford that difficult task is to promote in the field of university education different activities such as information exchange, cross-cutting networks, research studies, experimental ICT tools development and adequate dissemination. This proposal is structured in this sense to arouse the interest and participation of teachers, students and researchers in these actions, establishing collaborative projects and work proposals.*

**Keywords:** *Design for all, Cultural Heritage conservation, Universal Accessibility, ICT for Inclusivity.*

---

## **1. Introduction**

Among the 2030 sustainable development goals set by the United Nations, the following are included among the target indicators of Goal 10 “Reduce inequality within and among countries” (United Nations, 2015):

*10.2 By 2030, empower and promote the social, economic and political inclusion of all, irrespective of age, sex, disability, race, ethnicity, origin, religion or economic or other status*

*10.3 Ensure equal opportunity and reduce inequalities of outcome, including by eliminating discriminatory laws, policies and practices and promoting appropriate legislation, policies and action in this regard*

One of the reasons for inequality today is the limitations of physical, sensory or psychic type of some people who condition or prevent their access to certain natural or built spaces, tourist places, public resources, etc., and ultimately, live in the same conditions as the rest of the people.

Among these inequalities, we can highlight the problems of access to public, cultural and linked spaces to natural or built heritage. There are several, although scattered, initiatives and resources available following the principles of Universal Design or design for all (M. Story, Mueller, & Mace, 1998). From 1998, these studies are trying to relieve or improve the situation (Patrick Langdon, Lazar, Heylighen, & Dong, 2018; M. F. Story, 1998).

On the other hand, there is a tendency nowadays to properly use the resources of cities to achieve universal cultural diffusion, leisure activities and sustainable tourism. The opportunities are based on the preservation of heritage environments, natural or built, balanced development mechanism in certain areas or territories facilitating universal accessibility. In this sense, digital resources and software applications can be used in Cultural Heritage to overcome the barriers and develop the sustainable tourism (Addison, 2001; Bruno et al., 2018; Ruffino et al., 2019)

In this sense, Goal 11 “Make cities and human settlements inclusive, safe, resilient and sustainable” proposes the following goals related to accessibility to heritage resources (United Nations, 2015):

*11.3 By 2030, enhance inclusive and sustainable urbanization and capacity for participatory, integrated and sustainable human settlement planning and management in all countries*

*11.4 Strengthen efforts to protect and safeguard the world’s cultural and natural heritage*



*11.7 By 2030, provide universal access to safe, inclusive and accessible, green and public spaces, in particular for women and children, older persons and persons with disabilities*

*11.A Support positive economic, social and environmental links between urban, peri-urban and rural areas by strengthening national and regional development planning*

## **2. Background**

The UPV work team has teachers who have taught courses and seminars on this topic. Projects, study cases and examples of accessibility in Heritage in Valencia and its province have been analysed with students, both in public space and in different Heritage buildings.

The experience has been very satisfactory, also involving professionals from other universities and the Public Administration. To advance the proposal, collaborations of partners who have worked in this field, especially in software applications, are needed to adapt them to this topic.

## **3. Proposal approach**

The proposed initiative tries to collect in a transversal way those aspects of design, evaluation of the current state, improvement of the management and diffusion, as well as of the development of the territory incorporating them to the university academic formation.

This proposal is intended to involve students and teachers of different university degrees to develop studies, lines of research and computer APP, which facilitate the inclusiveness of people with some type of disability.

Therefore, this proposal aims to find partners from European universities that want to participate in this joint project of approximation to the different resources of cultural heritage to all people.

### **3.1. Objectives**

The main objective of the proposal will be to create a network of partners between European Universities for the promotion of universal access to natural and built heritage, to create safe, inclusive and accessible environments, through the use of communication and information systems (ICT).

This main objective is developed through the following secondary objectives:

1. Create an information exchange platform with examples of good practices.
2. Submit proposals to public research calls.

3. Exchange experiences in training through seminars, courses or conferences.
4. Encourage internship and final master's work on issues of universal accessibility and inclusiveness in natural and built heritage.
5. Develop computer tools that facilitate inclusiveness and universal accessibility.

### **3.2. Work plan**

To achieve the stated objectives, the following work plan is proposed:

First: To analyse the current situation in the different countries of the European Union

Second: To study the state-of-the-art in different areas from a multidisciplinary perspective: natural spaces, urban planning, architecture, archaeology, museums, etc.

Third: To analyse and compare the guides and recommendations, as well as the regulations of the different countries of the European Union.

Fourth: To create an information exchange platform to share publications, scientific articles, news, events, etc., and disseminate them.

Fifth: To develop software applications (app) to facilitate inclusiveness and accessibility to natural and built heritage.

Sixth: To supervise projects and master thesis that propose analysis and solutions in locations that present problems, needs or risks.

Seventh: To publish the results.

### **References**

- Addison, A. A. (2001). Virtual Heritage - Technology in the Service of Culture. In *VAST 2001: Virtual Reality, Archaeology, and Cultural*, (pp. 1–12). <https://doi.org/10.1145/584993.585055>
- Bruno, F., Barbieri, L., Lagudi, A., Cozza, M., Cozza, A., Peluso, R., & Muzzupappa, M. (2018). Virtual dives into the underwater archaeological treasures of South Italy. *Virtual Reality*, 22(2), 91–102. <https://doi.org/10.1007/s10055-017-0318-z>
- Langdon, Patrick, Lazar, J., Heylighen, A., & Dong, H. (2018). *Breaking down barriers : usability, accessibility and inclusive design*. (Pat Langdon, J. Lazar, A. Heylighen, & H. Dong, Eds.). Springer. <https://doi.org/https://doi.org/10.1007/978-3-319-75028-6>
- United Nations, U. (2015). Sustainable Development Knowledge Platform. Retrieved October 9, 2019, from <https://sustainabledevelopment.un.org/#>
- Ruffino, P. A., Permadi, D., Gandino, E., Haron, A., Osello, A., & Wong, C. O. (2019). DIGITAL TECHNOLOGIES FOR INCLUSIVE CULTURAL HERITAGE: THE CASE STUDY OF SERRALUNGA D'ALBA CASTLE. In *ISPRS Annals of Photogrammetry, Remote Sensing and Spatial Information Sciences* (Vol. IV-2/W6,

pp. 141–147). <https://doi.org/10.5194/isprs-annals-iv-2-w6-141-2019>

Story, M. F. (1998). Maximizing Usability: The Principles of Universal Design. *Assistive Technology*, 10(1), 4–12. <https://doi.org/10.1080/10400435.1998.10131955>

Story, M., Mueller, J. L., & Mace, R. L. (1998). The Universal Design File: Designing for People of All Ages and Abilities. *Design Research and Methods Journal*, 1(5), 165. <https://doi.org/10.1073/pnas.95.12.6854>

5th CARPE Conference  
HORIZON EUROPE AND BEYOND



UNIVERSITAT  
POLITÈCNICA  
DE VALÈNCIA

VALENCIA (Spain)

23-25<sup>TH</sup> OCTOBER 2019

**SUSTAINABILITY**



UNIVERSITY of  
DEBRECEN



## Active Power Filter Shape Class Model Predictive Controller tuning by Multiobjective Optimization

Carlos Cateriano Yáñez<sup>1</sup>, Jörg Richter<sup>2</sup>, Georg Pangalos<sup>2</sup>, Gerwald Lichtenberg<sup>3</sup>, Javier Sanchís Saez<sup>4</sup>

<sup>1</sup>Universitat Politècnica de Valencia, Spain; <sup>2</sup>Fraunhofer Institute for Silicon Technology, Hamburg University of Applied Sciences, Germany, <sup>3</sup>Hamburg University of Applied Sciences, Germany, <sup>4</sup>Department of Systems Engineering and Control, Universitat Politècnica de Valencia, Spain.

---

### **Abstract**

*In order to compensate the power quality issues that arise in distribution grids with high penetration of renewable energy sources, an active power filter device controlled by a novel model-based predictive controller, i.e. the linear state signal shaping model predictive controller, is implemented. This paper proposes the use of a Multiobjective Optimization evolutionary algorithm, i.e. the Multiobjective Differential Evolution with Spherical Pruning X, for the tuning of this novel controller. An application example for power quality compensation of a grid modeled as a switched system with four modes is given. The model includes nonlinear loads that introduce harmonic distortion and multiple consumer loads that enable the existence of conflicting objectives, typical of multiobjective optimization problems. A decision making strategy is developed in order to find the best controller parameters in a reasonable amount of time that enable the provision of optimal power quality services by balancing multiple objectives that can conflict with each other.*

**Keywords:** Power quality, harmonic mitigation, load compensation, active power filters, model predictive control, multiobjective optimization.

---

## 1. Introduction

As the share of renewable energy sources (RES) in distribution grids increases, several power quality challenges arise. Due to its intermittent nature, RES lead to voltage and frequency fluctuations in the grid that affect power quality. Moreover, as RES are connected via power converters, there is also a higher harmonic distortion pollution introduced by the switching power electronics involved (Liang, 2017).

A proven solution is the implementation of Active Power Filters (APF), which can compensate the unbalanced, harmonic, and reactive components of a load. In this context, the selection of an appropriate control strategy is critical (Kumar & Mishra, 2016).

This paper uses a novel Linear State Signal Shaping Model Predictive Control (LS<sup>3</sup>MPC) approach (Cateriano Yáñez et al., 2018). This strategy forces the states of a linear system to follow specific linear dynamics, i.e. a shape class, by reformulating a quadratic Model Predictive Control (MPC). The LS<sup>3</sup>MPC can compensate harmonic distortion under different load scenarios, compared to classical APF control methods (Weihe et al., 2018).

The evolutionary algorithm Multiobjective Differential Evolution with Spherical Pruning X (spMODEx) (Reynoso Meza et al., 2017), is proposed for the tuning of the LS<sup>3</sup>MPC control parameters, to enhance its power quality compensation capabilities. A simulation setup with a grid modeled as a switched system with four modes is developed as an application example. The guidelines for a decision making strategy process to choose the optimal controller parameters set are presented.

The paper is organized as follows. Section 2 introduces the models of the grid for the plant simulation and controller. In section 3, an overview of the harmonic shape class LS<sup>3</sup>MPC is given. Section 4 introduces the multiobjective optimization (MOO) setup, whereas section 5, covers the experiment setup and the analysis of the simulation results. Finally, section 6 summarizes the findings and draws conclusions.

## 2. Grid model with an active power filter

This section introduces a general definition for state space models, followed by a description of the models used for the plant simulation and for the controller.

### 2.1. State space models

Linear systems dynamics can be represented by a discrete-time state space model

$$\mathbf{x}(k+1) = \mathbf{A}\mathbf{x}(k) + \mathbf{B}\mathbf{u}(k) + \mathbf{E}\mathbf{d}(k), \quad (1)$$

with sampling time  $t_s$  at  $t = kt_s$ , state vector  $\mathbf{x} \in \mathbb{R}^n$ , input vector  $\mathbf{u} \in \mathbb{R}^m$ , disturbance vector  $\mathbf{d} \in \mathbb{R}^z$ , system matrix  $\mathbf{A} \in \mathbb{R}^{n \times n}$ , input matrix  $\mathbf{B} \in \mathbb{R}^{n \times m}$ , and disturbance matrix  $\mathbf{E} \in \mathbb{R}^{n \times z}$ .

## 2.2. Plant model description

A four mode switched grid circuit is given in *Figure 1*. From left to right, the supply voltage  $V_s$  denotes the external grid coupling, followed by the transmission line TL1 into the point of common coupling PCC1. From PCC1, there is a feeder line F1 that leads to the rectifier D1 (shown connected) and a parallel load line L1. There is a second transmission line TL2 connecting PCC1 with PCC2. From PCC2, there is a feeder line F2 that leads to the rectifier D2 (shown disconnected), a parallel load line L2, and a compensation source CS. The switching of the rectifiers D1 and D2 introduce harmonic distortion to the system, which is to be compensated by the compensation source CS.

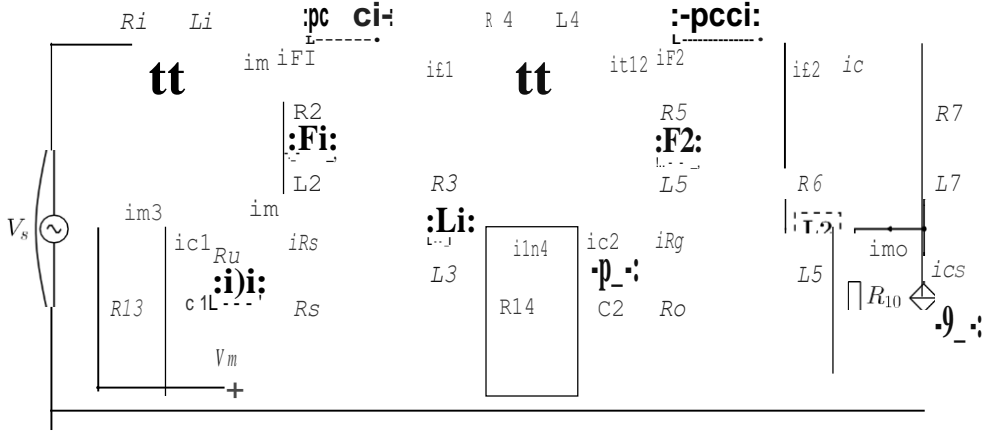

Figure 1. Grid circuit with rectifier D1 connected and rectifier D2 disconnected (Richter, 2018).

Depending on the switching state (on/off) of the rectifiers D1 and D2, the system is in one of four mutually exclusive modes. The switching conditions are in Table 1. Each configuration gives a different state space model, which is discretized by zero-order hold, leading to the signal vectors

$$\begin{aligned} \mathbf{x} &= [ i_{t1} \quad i_{t2} \quad i_{L1} \quad i_{L2} \quad i_{F1} \quad i_{F2} \quad i_C \quad V_{C1} \quad V_{C2} ]^T, \\ u &= i_{CS}, \\ \mathbf{d} &= [ V_s \quad V_{D1} \quad V_{D2} ]^T, \end{aligned} \quad (2)$$

with the corresponding matrices  $\mathbf{A} \in \mathbb{R}^{9 \times 9}$ ,  $\mathbf{B} \in \mathbb{R}^{9 \times 1}$ , and  $\mathbf{E} \in \mathbb{R}^{9 \times 3}$ .

Table 1. Four mode switching conditions for rectifiers D1 and D2

	D2 on	D2 off
D1 on	$ V_{R8}  \geq V_{C1} + V_{D1} + V_{R11}$ $ V_{R9}  \geq V_{C2} + V_{D2} + V_{R12}$	$ V_{R8}  \geq V_{C1} + V_{D1} + V_{R11}$ $ V_{R9}  < V_{C2} + V_{D2} + V_{R12}$
D1 off	$ V_{R8}  < V_{C1} + V_{D1} + V_{R11}$ $ V_{R9}  \geq V_{C2} + V_{D2} + V_{R12}$	$ V_{R8}  < V_{C1} + V_{D1} + V_{R11}$ $ V_{R9}  < V_{C2} + V_{D2} + V_{R12}$

Source: (Richter, 2018)

### 2.3. Simplified internal model description

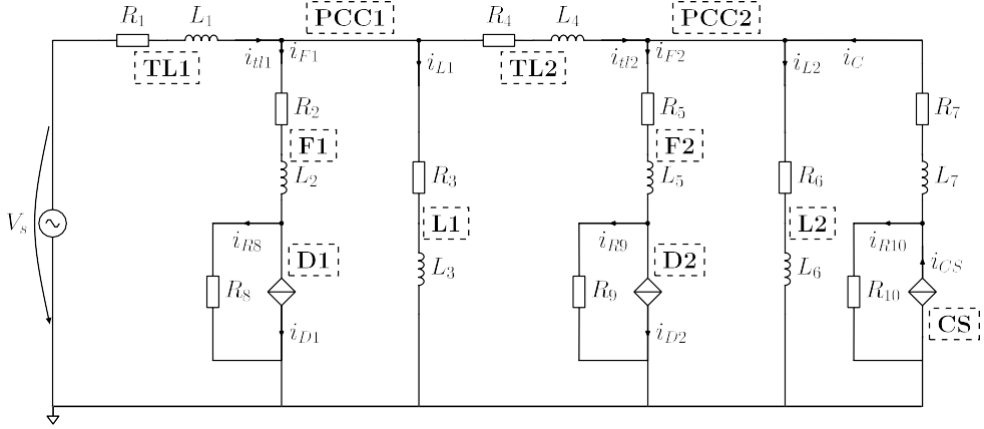

Figure 2. Simplified controller model ideal current source disturbances (Richter, 2018).

For the controller, the simpler model in Figure 2 is used to reduce complexity for the MPC. The difference is the replacement of rectifiers by ideal current sources. By excluding the switching from the rectifiers the four mode model is disregarded, leading to a single discrete-time state space model with signal vectors

$$\begin{aligned} \mathbf{x} &= [ i_{t1} \quad i_{t2} \quad i_{L1} \quad i_{L2} \quad i_{F1} \quad i_{F2} \quad i_C ]^T, \\ u &= i_{CS}, \\ \mathbf{d} &= [ V_s \quad i_{D1} \quad i_{D2} ]^T, \end{aligned} \quad (3)$$

and corresponding matrices  $\mathbf{A} \in \mathbb{R}^{7 \times 7}$ ,  $\mathbf{B} \in \mathbb{R}^{7 \times 1}$ , and  $\mathbf{E} \in \mathbb{R}^{7 \times 3}$ .

This makes a mismatch between the plant model as in (2) and the controller model.

However, the MPC feedback from the plant corrects the states mismatch in each iteration.

## 3. Shape class model predictive control

This section introduces the harmonic shape class control concept, while describing the necessary steps to reformulate a standard quadratic MPC into an LS<sup>3</sup>MPC.

### 3.1. Harmonic shape class

The harmonic shape class defines the reference dynamics of the LS<sup>3</sup>MPC to compensate the total harmonic distortion (THD). The dynamics are given by the solution of the initial value problem of the homogeneous ordinary second order differential equation (ODE)

$$\frac{d^2 x(t)}{dt^2} + (2\pi f)^2 x(t) = 0, \quad (4)$$



that leads to a fundamental harmonic signal  $x(t)$  of frequency  $f$ , zero offset, and arbitrary amplitude. Approximating the second derivative in (4) by forward numerical differentiation

$$\frac{d^2 x(t)}{dt^2} \approx \frac{2x(k) - 5x(k+1) + 4x(k+2) - x(k+3)}{t_s^2}, \quad (5)$$

leads to a kernel form with harmonic shape class vector (Cateriano Yáñez et al., 2018)

$$\mathbf{v} = \frac{1}{t_s^2} \begin{pmatrix} 2 + (2\pi f t_s)^2 & 5 & 4 & -1 \end{pmatrix} \in \mathbb{R}^{1 \times 4}. \quad (6)$$

### 3.2. Linear state signal shaping model predictive control

The unconstrained quadratic MPC minimization problem is (Maciejowski, 2002)

$$\min_{\Delta \mathbf{U}(k)} \|\mathbf{X}(k) - \Xi(k)\|_{\mathbf{Q}}^2 + \|\Delta \mathbf{U}(k)\|_{\mathbf{R}}^2, \quad (7)$$

with future states prediction  $\mathbf{X}(k) \in \mathbb{R}^{H_p n}$ , future states reference  $\Xi(k) \in \mathbb{R}^{H_p n}$ , control input change  $\Delta \mathbf{U}(k) \in \mathbb{R}^{(H_u+1)m}$ , cost of control error matrix  $\mathbf{Q} \in \mathbb{R}^{H_p n \times H_p n}$ , cost of control effort matrix  $\mathbf{R} \in \mathbb{R}^{(H_u+1)m \times (H_u+1)m}$ , for the prediction horizon  $H_p \in \mathbb{N}$ , and control horizon  $H_u \in \mathbb{N}$ . This quadratic optimization problem can be reformulated into the minimization of the harmonic shape class error by setting  $\Xi(k)$  to zero and embedding the harmonic shape class from (6) into the cost of control error matrix  $\mathbf{Q}$  (Cateriano Yáñez et al., 2018).

## 4. Multiobjective optimization

This section describes the MOO problem, including the definition of Pareto optimality, and then presents the evolutionary algorithm spMODEx, which is used to solve it.

### 4.1. Multiobjective optimization problem

The MOO problem is formally given as

$$\min_{\zeta} \mathbf{J}(\zeta) = \min_{\zeta} [J_1(\zeta), \dots, J_{\check{m}}(\zeta)], \quad (8)$$

subject to  $\mathbf{g}(\zeta) \leq \mathbf{0}$  and  $\mathbf{h}(\zeta) = \mathbf{0}$ , with  $\zeta \in \mathbf{O} \subseteq \mathbb{R}^{\check{j}}$  as the vector of decision variables from  $j \in \{1, \dots, \check{m}\}$ , searching the space  $\mathbf{O}$ , the objective function vector as  $\mathbf{J}(\zeta) \in \wedge \subseteq \mathbb{R}^{\check{m}}$ , and  $\mathbf{g}(\zeta)$  and  $\mathbf{h}(\zeta)$  as the inequality and equality constraints, (Reynoso Meza et al., 2017). This optimization problem can be solved either by aggregating the elements of the objective vector with a specific weighting  $q_k$

$$\min_{\zeta} \mathbf{J}(\zeta) = \min_{\zeta} \sum_{k=1}^{\check{m}} q_k J_k(\zeta) \quad (9)$$

or by first computing the Pareto optimal solutions and then choosing one of these.

#### 4.2 Pareto optimality

A solution vector  $\zeta^*$  is Pareto optimal if  $\nexists \zeta \in \mathbf{O} : \zeta \leq \zeta^*$ , where  $\zeta \leq \zeta^*$  means that  $\mathbf{J}(\zeta)$  is not worse than  $\mathbf{J}(\zeta^*)$  in all objectives, and is better in at least one objective. In other words, the set of Pareto optimal solutions is the set of cost function vectors with the property that no other vector can be found that is having all entries smaller than one of the solutions.

#### 4.3. Multiobjective Differential Evolution with Spherical Pruning X

The algorithm spMODEx employs a version of the differential evolution algorithm as an evolutionary algorithm. In addition, there is an archive to continuously update the population of the differential evolution algorithm to prevent stagnation and ensure a well spread Pareto front. The pruning algorithm applied is called spherical pruning. The general working sequence of the algorithm is depicted in Figure 3.

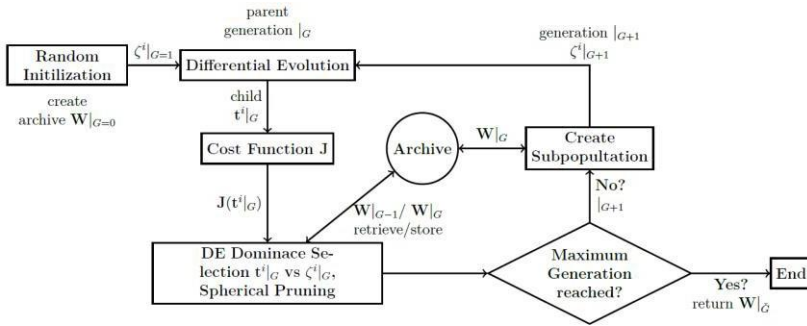

Figure 3. Graphical representation of spMODEx (Richter, 2018).

### 5. Setup of experiment, simulation results and analysis

This section describes the tuning process of an APF using a MOO algorithm. First the cost function, which is key for a successful controller tuning, and the tuning parameters are given. Then the Pareto optimal solutions are presented and discussed.

#### 5.1. Cost function and tuning parameters

The cost function addresses the following six objectives: The total harmonic distortion of the currents  $i_{H1}$ ,  $i_{H2}$ , and  $i_{CS}$ ; in  $J_1$ ,  $J_2$  and  $J_4$  respectively; the apparent control power  $P = i_{CS} v_{CS}$  in  $J_3$ , the reactive power factor (phase shift between  $i_{H1}$  and  $i_{CS}$ ) in  $J_5$  and the root mean square value of  $i_{H1}$  in  $J_6$ . For detail on the voltages and currents see **Error! Reference source not found.**

The tuning parameters are the weighting factors of the shape classes for the different states. For each state the shape class can ensure harmonic behavior by appropriately setting the entries of the weighting matrices. A degree of freedom is a factor for the shape class. These factors are chosen as decision variables.

### 5.2. Simulation results

To display the simulation results level diagrams are used. In Figure 4 the Pareto optimal solutions for the tuning of the APF are given. One solution is hereby divided into six different plots. To see one exact solution the numbers on the ordinate are used to identify a solution, i.e. the costs of all objectives for one solution are on the same level.

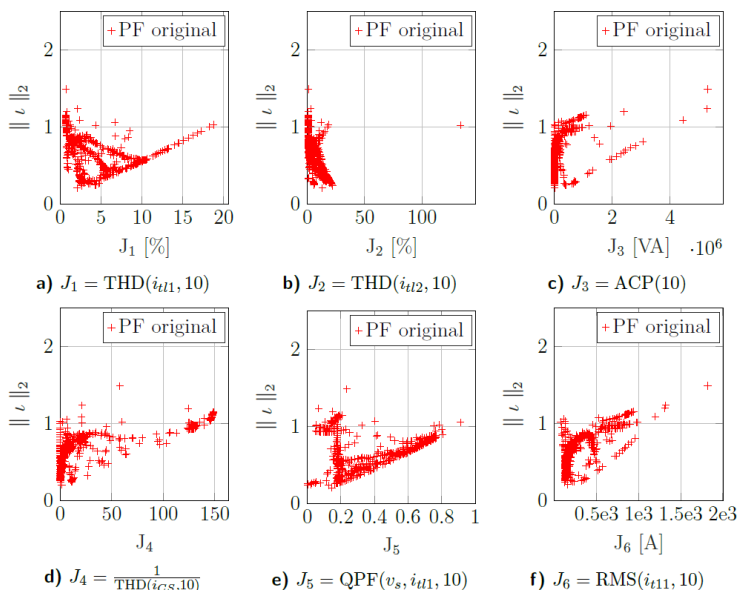

Figure 4. Level diagrams of the Pareto optimal solutions, (Richter, 2018).

### 5.3. Results analysis and decision making

To select a suitable parameters set, this solution can be further pruned. E.g. solutions having a THD value of more than 5% are not in compliance with standard grid codes such that these solutions can be discarded. After this, a trade of between the remaining solutions can be chosen as an informed choice.

## 6. Summary and conclusions

In this paper a controller tuning procedure for the novel LS<sup>3</sup>MPC on the basis of MOO was presented. The basics of shape classes are given and the connection to MPC is illustrated. The applied MOO algorithm spMODEx is illustrated as well. As an application example, the control of an APF is under investigation. The controller is tuned by optimizing the factors of the shape class for the different states of the given grid model.

Future research is done by adapting the optimization problem of the underlying LS<sup>3</sup>MPC from an unconstrained to a constrained optimization problem, giving additional degrees of freedom to the controller tuning, which could then efficiently be solved using the spMODEx evolutionary algorithm.

## Acknowledgement

This contribution was partly developed within the project NEW 4.0 (North German Energy Transition 4.0) which is funded by the German Federal Ministry for Economic Affairs and Energy (BMWi). This paper was also partly funded by the Free and Hanseatic City of Hamburg (Hamburg City Parliament publication 20/11568).

## References

- Cateriano Yáñez, C., Pangelos, G., & Lichtenberg, G. (2018). An Approach to linear state Signal Shaping by quadratic Model Predictive Control. 2018 European Control Conference (ECC), 1–6. <https://doi.org/10.23919/ECC.2018.8550379>
- Kumar, P., & Mishra, M. K. (2016). A comparative study of control theories for realizing APFs in distribution power systems. 2016 National Power Systems Conference (NPSC), 1–6. <https://doi.org/10.1109/NPSC.2016.7858905>
- Liang, X. (2017). Emerging Power Quality Challenges Due to Integration of Renewable Energy Sources. *IEEE Transactions on Industry Applications*, 53(2), 855–866. <https://doi.org/10.1109/TIA.2016.2626253>
- Maciejowski, J. M. (2002). *Predictive Control with Constraints*. Pearson education.
- Reynoso Meza, G., Blasco Ferragud, X., Sanchis Saez, J., & Herrero Durá, J. M. (2017). Controller Tuning with Evolutionary Multiobjective Optimization. <https://doi.org/10.1007/978-3-319-41301-3>
- Richter, J. (2018). *Model Predictive Controller Tuning in Electrical Distribution Grids by Multiobjective Optimization*. Hamburg University of Applied Sciences.
- Weihe, K., Cateriano Yáñez, C., Pangelos, G., & Lichtenberg, G. (2018, July). Comparison of Linear State Signal Shaping Model Predictive Control with Classical Concepts for Active Power Filter Design. 167–174. <https://doi.org/10.5220/0006910401670174>

## Consumer habits and preferences in the renewable energy market

Péter Balogh<sup>1</sup>, Attila Bai<sup>1</sup>, Károly Pető<sup>1</sup>, Zoltán Szakály<sup>1</sup>

<sup>1</sup>Faculty of Economics and Business, University of Debrecen, Hungary

---

### **Abstract**

*Renewable energy sources can have considerable potential for residential cost reduction, sustainable energy consumption and local income production.*

*Our aim is to analyse the knowledge of Hungarian consumers about renewable energy sources, their willingness to apply them and the socio-demographic factors concerning these issues. To achieve the research objectives, a nationally representative survey with 1000 people was launched in April 2019 in Hungary.*

*Based on the results of the questionnaire, it was concluded that the information people have is below the average in the case of every examined renewable energy source, which is especially true for biomass-based energy sources. Convenience is almost as important as environment friendliness. An excessively high rate of respondents (34 and 27%) is interested in solar panels and solar collectors, while 32% of them are unwilling to use these energy sources.*

*It would be justified to extend this consumer research in the future for more countries. The authors wish to clarify how the differences in location, income status, residential segment and values influence the spread of these energy sources in the EU and what tools could promote their use in the future.*

**Keywords:** *energy, consumption, attitude, segmentation, knowledge*

---

## **1. Introduction**

World energy consumption was about 567-578 EJ in 2017, which is still on the increase – in 2017 by 2.2%, and by 1.7% on average yearly since 2006 (BP, 2018, IEA, 2018). Within this, the consumption of the residential segment plays a significant role both in the EU (42%) and in Hungary (35%) as well (Eurostat, 2019). The Hungarian population spend 12.8% (35 EUR/capita/month) of their income on energy sources, and this rate is even higher in the case of pensioners, singles and lower income groups (KSH, 2019). At the same time, the rate of renewables in the energy mix has stagnated for years worldwide (14%), it is a bit higher in the EU and in Hungary than the world average (18-18%, IEA, 2018). Thus, renewable energy sources can have considerable potential for residential cost reduction, sustainable energy consumption and local income production.

Our aim is to analyse the knowledge of Hungarian consumers about renewable energy sources, their willingness to apply them and the related socio-demographic factors. To achieve the research objectives, a nationally representative survey with 1000 people was launched in April 2019 in Hungary.

## **2. Literature review**

In their case study Assefa and Frostelld (2007) assessed the social acceptance of energy technologies with regard to the knowledge and fear associated with them. The findings of the study indicated that social acceptance was a crucial factor in the future spread of these technologies, whereas the lack of reliable knowledge could have extremely adverse effects on acceptance.

Prior to the current study, several surveys were already conducted in Hungary, aiming at assessing the knowledge of different social segments concerning different renewable energy technologies.

According to a questionnaire-based survey on energy recovery from by-products in 1996 by Bai (1998), with the polarization of the society the price of energy is becoming a vital factor for an increasing number of people and this may outweigh reasons of convenience. Biobriquette was found to arouse the most interest among the participants of the survey.

Tóth (2013) carried out representative research in one of the most underdeveloped regions of Hungary (the valley of River Hernád), in which he concluded that people were primarily motivated by the possibility of reducing costs, however their lack of information hindered the selection of the appropriate energy source. Current communication channels provided the population with little and often false information. The knowledge of different age groups differed to a great extent and owing to internet usage younger people showed more awareness. Current Geography textbooks in elementary and secondary schools contained very little, disproportionately distributed and outdated information about renewable energy resources (Pajtkóné Tari et al. 2011). Only 10–15% of those surveyed in the area were found to be willing to accept the implementation of large-scale renewable investment projects in their own settlements.

Jobbágy conducted research among Hungarian motorists on biofuels. According to his findings, respondents typically reflected a positive attitude to biofuels, especially in terms of environmental protection, and their knowledge did not fall behind the European or North American average. The main source of their knowledge was the Internet, which is welcome on the one hand, since that is the quickest possible way to acquire the latest, updated information. On the other hand, however, it also poses risks, as false information is equally easily accessible and the source of information is often difficult to verify (Jobbágy, 2013).

### **3. Methodology**

In order to achieve the objectives of the research a nationally representative questionnaire-based survey with 1000 people was launched in April, 2019 in Hungary. During sampling in the given regions representativeness was per se provided, thus its structure was fully compliant with the quota established previously by the Hungarian Central Statistical Office (quota sampling).

The settlements in the given regions and the addresses in the settlements were selected by drawing lots (simple random sampling). The so-called random walking principle was applied in the designated settlements, which provided complete randomness in the selection of suitable respondents. As a second step the person for the interview from among the members of the households visited was selected by using the so-called „birthday key”. The principle of the method is that the person,

whose birthday comes closest to the day of the interview from among people of the appropriate age (18 years of age or above) must be chosen for the interview.

As random sampling did not grant representativeness between the sample and the population, the sample had to be corrected by using multidimensional weightings according to gender and age. After correction the sample represents the composition of population based on four factors (region, type of settlement, gender and age).

For the evaluation of the database, besides statistical indicators (mean, standard deviation, frequency, median, mode), hypothesis tests were also carried out. During this procedure, a test of independence (Chi-Square, contingency coefficient) was used to determine the relationship between the different socio-demographic categories and the most important economic and marketing factors influencing the future spread of renewable energy sources. The level of significance used by us was 5%.

#### **4. Results and Recommendations**

Based on the results of the questionnaire, it was concluded that the information people had was below the average in the case of every examined renewable energy source, which was especially true for biomass-based energy sources. Convenience is almost as important as environment friendliness.

The findings of our study suggest that the differences with regard to the basic level knowledge about renewable energy resources can be summarized as follows:

- Differences by gender  
no difference: solar, wind, hydropower  
there is a significant difference in favour of men: geothermal energy, heat pumps, biobriquette, wood pellet, biogas, biodiesel, bioethanol
- Qualifications play a significant role in the awareness of every examined energy source, people with elementary schooling are significantly uninformed as compared to others.
- People living in the capital have heard less about wind energy and more about geothermal energy, biobriquette, wood pellet, biodiesel, and bioethanol than those living in other types of settlements. Solar- and hydroenergy have been found to be at the same awareness level in different types of settlements.



- Based on our research environment-consciousness does not make a difference as regards awareness.
- People with higher income are considerably more aware of energy sources available at higher prices (geothermal energy, heat pumps, wood pellet, biogas, biodiesel, bioethanol).

An excessively high rate of respondents (34 and 27%) is interested in solar panels and solar collectors, 32% of them are unwilling to use these energy sources.

Overall, when buying energy, people make their decisions based mostly on cheap running costs and convenience factors, rather than on environmentally friendly considerations. For 54% of all respondents environment protection proved to be the least important factor to consider.

It would be justified to extend this consumer research in the future for more countries. The authors wish to clarify how the differences in location, income status, residential segment and values influence the spread of these energy sources in the EU and what tools could promote their use in the future.

### **Acknowledgment**

This research was supported by EFOP-3.6.1-16-2016-00022 „Debrecen Venture Catapult Program”.

The research was financed by the Higher Education Institutional Excellence Programme (20428-3/2018/FEKUTSTRAT) of the Ministry of Human Capacities in Hungary, within the framework of the 4. thematic programme of the University of Debrecen.

### **References**

1. Assefa, G., Frostell B. (2007): Social sustainability and social acceptance in technology assessment: a case study of energy technologies, *Technol. Soc.* 29 pp. 63-78.
2. A. Bai, E. Durkó, K. Tar, J. B. Tóth, I. Lázár, L. Kapocska, A. Kircsi, B. Bartók, R. Vass, J. Péntzes, T. Tóth: Social and economic possibilities for the energy utilization of fitomass in the valley of the river Hernád *Renewable Energy*, RENEWABLE ENERGY, Volume 85, ISSN: 0960-1481, [doi:10.1016/j.renene.2015.06.069](https://doi.org/10.1016/j.renene.2015.06.069)

3. Bai A.: A mezőgazdasági és élelmiszeripari melléktermékek energetikai hasznosításának gazdasági összefüggései. Doktori (Ph. D.) értekezés. Debrecen, 1998., pp. 1-168.
4. BP (British Petrol, 2018): Statistical Review of World Energy. 67th edition, pp. 1-52
5. Eurostat (2019): [https://ec.europa.eu/eurostat/statistics-explained/index.php/Renewable\\_energy\\_statistics](https://ec.europa.eu/eurostat/statistics-explained/index.php/Renewable_energy_statistics)
6. International Energy Agency (IEA, 2018): Key World Energy Statistics. [www.iea.org/statistics](http://www.iea.org/statistics), pp. 1-51
7. Jobbágy, P. (2013): A hazai biodízel-ágazat komplex elemzése. Doktori (Ph.D.) értekezés. Ihrig Károly Gazdálkodás- és Szervezéstudományok Doktori Iskola. pp. 1-159.
8. KSH (Hungarian Central Statistic Agency, 2019). [http://www.ksh.hu/thm/3/indi3\\_1\\_2.html](http://www.ksh.hu/thm/3/indi3_1_2.html)
9. Pajtkóné Tari I.–Kiss B.–Ruszkai Cs.–Mika J. (2011): A megújuló energiák internetes forrásainak felhasználása a földrajzoktatásban. – In. SZABÓ V.–FAZEKAS I. (szerk.): Környezettudatos energiatermelés és -felhasználás. Meridián Alapítvány, Debrecen. pp. 264–269.
10. Tóth T. (2013) A megújuló energiaforrások társadalmi háttérvizsgálata a Hernád-völgy településein, különös tekintettel a dendromassza-alapú közösségi hőenergia-termelésre értekezés. Doktori (Ph.D.) értekezés. Földtudományok Doktori Iskola. pp. 1-159.

## Circularity in value chains for building materials

Evert-Jan Velzing<sup>1</sup>, Annemiek van der Meijden<sup>1</sup>, Kitty Vreeswijk<sup>1</sup>, Ruben Vrijhoef<sup>1</sup>

<sup>1</sup> Research Centre for Healthy and Sustainable Living, University of Applied Sciences Utrecht, The Netherlands.

---

### **Abstract**

*The urgency for developing a circular economy is growing, and more and more companies and organisations are concerned with the importance of adapting their business to fit a changing economy. However, many analyses on the circular economy are still rather abstract and there is a lack of understanding about what circularity would mean for specific industries. This insufficient insight especially seems to be apparent in the building and construction sector. Besides, the building and construction sector is responsible for a major part of energy use and emissions.*

*To tackle the issue of insufficient insight into the business consequences of circular developments, further research is necessary. Therefore, we propose to collaborate on a research project that aims to provide a more detailed level of analysis. The goal is to identify drivers and barriers to make better use of materials in the building and construction sector. This further research would benefit from an international collaboration between universities of applied sciences and industry from different European countries. An additional benefit of the applied orientation would be the relevance for professional education programmes.*

**Keywords:** *Circular economy; circular strategy; building materials; value chain cooperation; circular business models.*

---

## **1. Introduction**

There is common understanding about the necessity for a transition to a circular economy (e.g. EC, 2015; UNCTAD, 2018; Mazzucato, 2018). However, many analysis and (policy) discussion about the transition to a circular economy take place on a macroeconomic level (e.g. Stahel, 2016; Ghisellini et al, 2016; Kirchherr et al, 2018). This makes terms such as ‘closing the loop’ and circularity catch-all terms, that do little to help businesses involved. Therefore, we argue that a more detailed level of analysis is needed in order to identify barriers that hold back the transition to a circular economy.

Because of their central role in consuming goods (UN, 2018) and energy (Chuchí et al, 2014) we focus on the building and construction sector. For instance, the Dutch building and construction sector is responsible for 50 percent of the resource use, 40 percent of the total energy use, 35 percent of the CO<sub>2</sub> emissions, and 30 percent from the total water usage (Nederland Circulair in 2050, 2016) . Moreover, around 40 percent of all Dutch waste is related to building or demolition work (CE, 2014; CBS et al, 2017). It is safe to assume that the scale of these figures are similar in other European countries.

Therefore, the building and construction sector can be seen as an important actor in actualizing the European Commission’s Circular Economy Action Plan. With this plan the European Commission aims to speed up the transformation of European industries to a circular economy and thereby make European company fit for the future (EC, 2015; EC, 2019).

## **2. The situation in the (circular) building economy**

In the quest to reach more sustainable development in the building economy, it is important to use resources more efficiently, and to make the built environment more circular. One way to contribute to this, is to use building materials in a circular way. This means to reuse demolition materials – materials that stem from buildings that are being refurbished or torn down. A lot of such materials are already available, and in the Netherlands there is already quite a demand for this, due to government policies.

However, supply and demand are not yet connected. There are several obstacles still hindering this. For example, demolition material is often quite old and does not fit current technical requirements. Even when it fits these requirements, it is not easy to integrate them into current building process, as these are often based on a software that needs a lot of technical information about the materials, which is not always readily available for used materials. Moreover, demolition materials often become accessible in moments that they are not yet needed in other building projects.

To reduce these obstacles, the transition to a circular building sector requires new ways to collaborate, new processes, and new business models.

### **3. Questions that arise**

In sum, there is need for more knowledge about and insight into the value chains within the building and construction sector. Only then, it would be feasible to develop the companies so they are fit for a circular building economy. To gain more knowledge on this subject, we focus on the use of materials in the building and construction sector, and we propose to start up a research project that aims to answer the following research question:

*What are the drivers and barriers to make better (re-)use of building and construction materials?*

In general both social and technical barriers will hamper the transition to a circular (building) economy (De Jesus & Mendonça, 2018). In order to better understand these barriers for specific materials in the building sector, we propose analyses that take different perspectives, such as: technical analysis of requirements and feasible circular strategies, research on value-chain cooperation and/or circular (eco)systems, and analysis of circular business models.

This can lead to the following research sub-questions:

- Which materials become available during refurbishing/demolition processes? And how many?
- What circular strategies can be used to make better use of materials?
- What are the requirements for reusing them?
- How can a sector of industry organize their value chain to facilitate viable circular strategies? What are the consequences for cooperation between actors involved?
- What business models support circular use of building materials?
- What circular business models can be proposed that support the reuse of demolition materials?

#### **4. Approach**

Because of the major role of the building and construction sector in energy and material use and the international dependence of value chains involved, it is beneficial to gather insight from different European countries. Therefore, we propose to set up an international collaboration of research institutes and industry partners. The urgency of the matter and the call for better understanding and even solutions, are arguments to take on an applied research approach. This means that we aim to execute detailed level analyses in existing value chains for both best practices and less performing examples.

We propose to base the analysis on case studies on existing building materials, such as concrete, bricks and synthetic building materials, and their actual value chains. We can use desk research based on both scientific and grey literature and in-depth interviews to answer the research questions mentioned above.

In order to be able to set up this research we seek to combine different specialisations. As a practice oriented research institute, HU University of Applied Sciences aims to transfer knowledge and to develop skills that are relevant for professional practice. This means that researchers from our institute have experience with practical oriented research projects, where companies are involved. The research group involved has wide experience in the construction sector and sustainable and circular urban area development. More specific, our expertise lies in circular business models, ecosystem or network creation, and assessing sustainable policy making. To form our collaboration we seek partners that have a knowledge base in the (circular) building economy and/or industries that produce materials being used in the building and construction sector. Besides, we look for partners with good relations with companies, so case studies in several countries can be done, and a multi-case study project can be formed within different cultural contexts.

## References

- CBS, PBL & Wageningen UR. (2017). *Vrijkomen en verwerking van afval per doelgroep, 1990-2014* (indicator 0206, versie 13, 26 januari 2017). Retrieved from: <https://www.clo.nl/indicatoren/nl0206-vrijkomen-en-verwerking-van-afval-per-doelgroep>
- Cuchí, A.; Arcas, J.; Casals, M. & Fobella, G. (2014). *Building a common home Building sector – A global vision report*. Produced by the Global Vision Area within the World SB14 Barcelona Conference.
- De Jesus, A. & Mendonça, S. (2018). Lost in Transition? Drivers and Barriers in the Eco-innovation Road to the Circular Economy. *Ecological Economics*, 145, 75-89. doi: 10.1016/j.ecolecon.2017.08.001.
- EC. (2015). *Closing the Loop – An EU action plan for the Circular Economy*. Brussels: European Commission.
- EC. (2019). *Report from the Commission to the European Parliament, the Council, the European Economic and Social Committee and the Committee of the Regions on the implementation of the Circular Economy Action Plan*. Brussels: European Commission.
- Ghisellini, P; Cialini, C. & Ulgiati, S. (2016). A review on circular economy: the expected transition to a balanced interplay of environmental and economic systems. *Journal of Cleaner Production*, 114, 11-32. doi: 10.1016/j.jclepro.2015.09.007.
- Kirchherr, J., Pisciceli, L., Bour, R., Kostense-Smit, E., Muller, J., Huibrechtse-Truijens, A. & Hekkert, M. (2018). Barriers to the Circular Economy: Evidence From the European Union (EU). *Ecological Economics*, 150, 264-272.
- Mazzucato, M. (2018). *Mission-Oriented Research & Innovation in the European Union – A problem-solving approach to fuel innovation-led growth*. Retrieved from: European Commission; [https://ec.europa.eu/info/sites/info/files/mazzucato\\_report\\_2018.pdf](https://ec.europa.eu/info/sites/info/files/mazzucato_report_2018.pdf)
- Nederland circulair in 2050. *Rijksbreed programma Circulaire Economie (2016)*. Den Haag: Ministerie van Infrastructuur en Milieu & Ministerie van Economische Zaken.
- Stahel, W.R. (2016) The Circular Economy. *Nature*, 531(7595), 435-438.
- UN. (2018). *2018 Global Status Report – Towards a zero-emission, efficient and resilient buildings and construction sector*. United Nations Environment Programme.
- UNCTAD. (2018). *Circular Economy: The New Normal* (Policy Brief No. 61). Retrieved from United Nations Conference on Trade and Development (UNCTAD): [https://unctad.org/en/PublicationsLibrary/presspb2017d10\\_en.pdf](https://unctad.org/en/PublicationsLibrary/presspb2017d10_en.pdf)

## **Monitoring and evaluation of thermal comfort in urban areas: application to Valencia city**

**David Alfonso-Solar<sup>1</sup> , Paula Bastida-Molina<sup>2</sup>, Lina Montuori<sup>1</sup>, Carlos Vargas-Salgado<sup>2</sup>,**

<sup>1</sup>Department of Applied Thermodynamics, Universitat Politècnica de Valencia, Spain,

<sup>2</sup>Department of Electrical Engineering, Universitat Politècnica de Valencia, Spain.

---

### ***Abstract***

*In this paper, it is presented preliminary results of a methodology for thermal comfort monitoring and evaluation in urban areas based on local metering of ambient conditions and Rayman model application. In the framework of GROWGREEN European project it was installed six monitoring stations for data acquisition of air temperature, relative humidity, wind speed, solar radiation and black globe temperature. Data of first 5 months of monitoring and modelling of one location with Rayman model to calculate PET (physiological equivalent temperature) is presented. Based on PET it was calculated the percentage of hours with thermal comfort per month, and it was made a comparison between PET and black globe temperature (GT) in order to evaluate the suitability of GT as a single, low cost and robust indicator of thermal comfort in urban areas.*

**Keywords:** *thermal comfort; monitoring; Rayman model; black globe temperature*

---



## **1. Introduction**

Climate change provides that heat stress periods frequency and intensity progressively increase, especially in warm climates as Mediterranean one. Additionally, big cities present the urban heat island effect so that built areas absorb more heat than natural areas (agricultural or forest areas) (Oke, 1982). These facts provide a significant health risk for the population (Rosenzweig *et al* , 2017) and comfort in outdoor areas is being reduced progressively and so, specific criteria and detailed information about urban thermal behaviour should be provided to urban management organizations (Blumberg, 2014 ; European Environment Agency, 2012). Urban planning, maintenance and refurbishment should use this information and focus on mitigating heat stress in warm climates cities.

GROW GREEN project through the delivery of four demonstration projects in a wide range of different geographical, climatic, political, governance, societal and financial scenarios, will establish the evidence that NBS<sup>1</sup> (Nature-based solutions) in cities provide a cost-effective, sustainable and replicable alternative to improve urban climate and water resilience, and deliver social, environmental and economic benefits.

Valencia city, in the framework of GROW GREEN project<sup>2</sup>, will demonstrate, through specific pilot actions, the feasibility, multi-benefits and effectiveness of NBS for urban heat management.

In this work it is presented preliminary result of heat stress monitoring and modelling results for two locations. Specific climatic parameters (Temperature, humidity, solar radiation, wind speed, black globe temperature) metering results (since January 2019), and PET (Physiological Equivalent Temperature) modelling through RAYMAN model will be compared.

## **2. Methodology**

For outdoor comfort evaluation, in two different urban locations in Valencia (Spain) city, it will be used PET (Physiologically Equivalent Temperature). The PET index has been used

---

<sup>1</sup> According to European Commission (EC) definition , Nature-based solutions are actions inspired by, supported by or copied from nature and which aim to help societies address a variety of environmental, social and economic challenges in sustainable ways.

<sup>2</sup> Grant Agreement number: 730283 — GROW GREEN — H2020-SCC-2016-2017/H2020-SCC-NBS-2stage-2016. <http://growgreenproject.eu/>





Figure 2. Location B: partial shadowing with trees (Andreu Alfaro street, Valencia, Spain)

For heat stress monitoring purposes it has been used a HSM (heat stress monitoring box), see Figure 3, with acquisition of data about black globe (BG) temperature, air temperature, humidity, wind speed and solar radiation. HSM boxes are attached to urban street lights posts and, always, south oriented.



Figure 3. HSM - Heat stress monitoring box.

In location A it has been checked that in Winter (January 2019) this box is metering undisturbed solar radiation from 9:00 in the morning to 18:00 in the afternoon, and so in summer (really may 2019) from 8:00 to 20:00.

Black globe<sup>3</sup> temperature consists of a hollow copper sphere (90 mm diameter) painted matt black, to absorb radiant heat, with a temperature sensor at its centre.

## 2.2. PET and Black globe evaluation and comparison

Both locations will be modelled with RAYMAN model software to evaluate PET in each hour during 6 months (from January to June 2019), and direct metering of black globe temperature is provided by HSM boxes (also hourly). With PET hourly values it will be calculated thermal comfort hours according to the following reference table (Matzarakis et al., 1999):

**Table 1. Thermal perception PET ranges.**

<b>Max.</b>	<b>Min.</b>	<b>Thermal perception</b>
	>41	Extreme heat stress
41	35	Strong heat stress
35	29	Moderate heat stress
29	23	Slight heat stress
23	18	No thermal stress
18	13	Slight cold stress
13	8	Moderate cold stress
8	4	Strong cold stress
	<4	Extreme cold stress

<sup>3</sup> For further information please see ISO 7726. Ergonomics of the thermal environment - Instrument for measuring physical quantities". Geneva, Switzerland: International Organization for Standardization. November 1998.

It will be compared, hour by hour, PET values with black globe (BG) temperature in order to evaluate the possibility of using BG as a single, simple and low cost indicator to monitor heat stress.

### 3. Results and discussion

In Table 2 it is included thermal perception hours evaluation in locations A and B (according to PET results):

**Table 2 . Thermal perception hours**

Thermal perception	LOCATION A		LOCATION B	
	Time(h)	%	Time(h)	%
Extreme heat stress	32	0,74	51	1,2
Strong heat stress	187	4,34	144	3,3
Moderate heat stress	426	9,86	192	4,4
Slight heat stress	580	13,42	277	6,4
No thermal stress	529	12,23	438	10,1
Slight cold stress	744	17,23	838	19,4
Moderate cold stress	636	14,73	992	23,0
Strong cold stress	574	13,30	800	18,5
Extreme cold stress	612	14,16	589	13,6

Considering HEAT STRESS as the addition of (Extreme heat stress) + (Strong heat stress) + (Moderate heat stress), it was concluded that there was HEAT STRESS 15% of the time in location A (where no shadowing is available) and only 9% of the time in location B. However it is interesting to notice that extreme heat stress hours are very low in both locations but slightly higher in location B. Looking at specific simulation results it was concluded that this is due to the fact that, as shadowing is only partial, when solar radiation was not blocked and temperature was high (aprox. in the mornings from 11:00 to 15:00, during may and june.)

PET was, sometimes, higher because wind speed (that usually improves thermal comfort in hot periods) was partially reduced by the trees.

In Figure 4 it has been included the comparison of PET and black globe temperature (January – June 2019, hourly values):

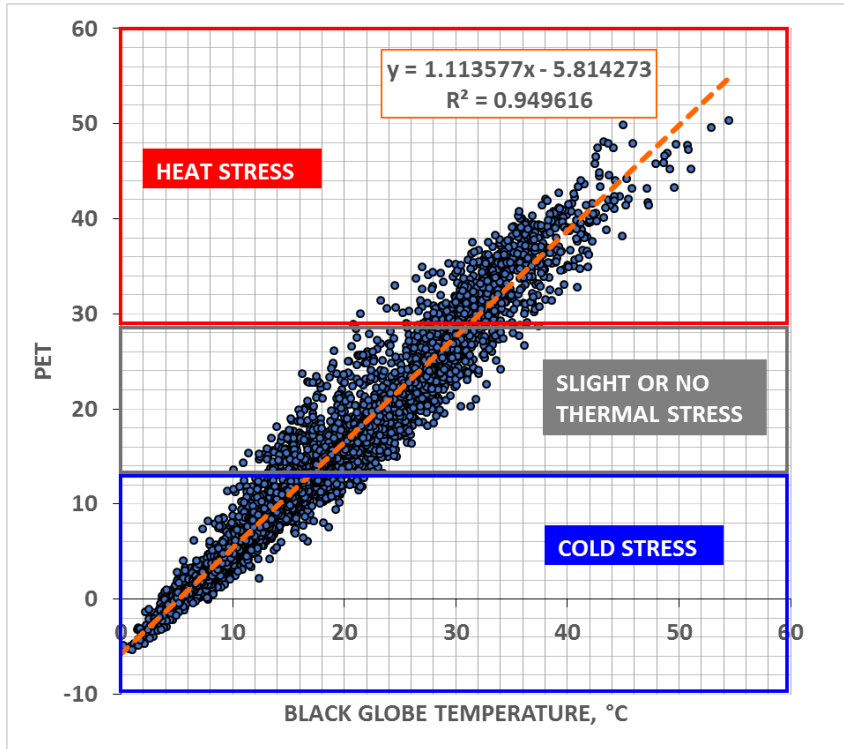

Figure 4. PET and Black globe temperature comparison

It can be concluded that there is an strong relationship and using linear approximation (other equations where tested but fitting was no improved significantly), it was observed an average error of 1.7 degree (with standard deviations of about 1.5 degrees, so most values with an error lower than 3.2 degrees) when calculating PET only with black globe temperature.

#### 4. Conclusions

Monitoring of heat stress was performed in Valencia from January to June 2019 in two different urban locations. RAYMAN simulations provided PET values and it was concluded that 9-15% of the time there was heat stress. For accurate PET modelling it was necessary many outdoor conditions parameters (temperature, wind,

humidity, solar radiation) however, based on preliminary results, acceptable approximations (average error or 1.7 PET degrees for absolute values in the range 20 – 50 PET degrees) can be done using just one metering variable, which is black globe temperature. However, more different locations and longer monitoring periods will be necessary to confirm these results.

## **Acknowledgements**

This work was supported by European Commission through GROW GREEN project (Agreement number: 730283 — GROW GREEN — H2020-SCC-2016-2017/H2020-SCC-NBS-2stage-2016. <http://growgreenproject.eu/>)

This work was supported in part by the regional public administration of Valencia under the grant ACIF/2018/106.

## **References**

- Oke, T.R. (1982). The energetic basis of the urban heat island. *Q. J. R. Meteorol. Soc.* **1982**, 108, 1–24.
- Rosenzweig, C.; Solecki, W.D.; Hammer, S.A.; Mehrotra, S. (2017). Climate Change and cities First Assessment Report of the Urban Climate Change Research Network. Available online: <http://uccrn.org/files/2015/01/ARC3-Frontmatter-Final.pdf> (accessed on 12 February 2017).
- Blumberg, G. (2014). Assessing the Potential Impact of Heat Waves in Cities: Implications for Hazard Preparation and Planning. *Procedia Econ. Financ.* **18**, 727–735.
- European Environment Agency (2012). *Urban Adaptation to Climate Change in Europe*; European Environment Agency: Copenhagen, Denmark, 2012.
- Matzarakis, A., Mayer, H., Iziomon, M.G., 1999. Applications of a universal thermal index: physiological equivalent temperature. *Int. J. Biometeorol.* **43**, 76–84.
- Matzarakis, A., Endler, C., 2010. Climate change and thermal bioclimate in cities: impacts and options for adaptation in Freiburg, Germany. *Int. J. Biometeorol.* **54**, 479–483.
- Matzarakis, A., Rutz, F., Mayer, H., 2007. Modelling radiation fluxes in simple and complex environments: application of the RayMan model. *Int. J. Biometeorol.* **51**, 323–334.
- Matzarakis, A., Rutz, F., Mayer, H., 2010. Modelling radiation fluxes in simple and complex environments: basics of the RayMan model. *Int. J. Biometeorol.* **54**, 131–139.



## Assessing the increase of solar fields in Iberian Peninsula

Paula Bastida-Molina<sup>1</sup>, David Alfonso-Solar<sup>2</sup>, Carlos Vargas-Salgado<sup>1</sup>, Lina Montuori<sup>2</sup>

<sup>1</sup>Department of Electrical Engineering, Universitat Politècnica de València, Spain,

<sup>2</sup>Department of Applied Thermodynamics, Universitat Politècnica de València, Spain.

---

### **Abstract**

*Spanish electrical generation has traditionally included high pollutant energy resources, like fuel or carbon. However, disturbing ever-increase in the average temperature of Planet Earth has led to a search for sustainability in the energy scenario. Therefore, Spanish electrical generation mix is prone to replace contaminant energy resources by non-contaminant, such renewables. Concretely, Spain is one of the countries with more solar peak annual hours. Nevertheless, having enough space to increase solar fields has been widely question. In this paper, an unrealistic scenario where all the annual Spanish consumption would be covered by photovoltaics is deeply analysed. Considering real electrical Spanish consumption data from 2017, required total quantity of solar panels has been quantified. Additionally, the study takes the hypothesis that all the panels should be placed on Spanish sunny desert zones for two main reasons. First, total solar peak annual hours there are higher than in other Spanish regions. Last, making there the installation would give use to previous wasted zones. Obtained results indicate that around 691 million of 330W<sub>p</sub> solar panels would be required for this issue, taking up 3799 km<sup>2</sup>. This space means only a 0.77% of all Iberian Peninsula. These outcomes clearly show that there is suitable and enough space to increase solar fields in Iberian Peninsula.*

**Keywords:** *Photovoltaics, solar fields, space, increase, Iberian Peninsula.*

---



## **1. Introduction**

Our Planet has been suffering a worrisome temperature growth for years, caused mainly by the enormous amount of carbon dioxide emitted to the atmosphere. If average temperature of Planet Earth continues increasing, the consequences for coming generations will be devastating (Ziegler, Morelli, & Fawibe, 2019). Preventing this situation has become one of the most important problems for almost every country. Therefore, a wide range of preventing climate change policies are being developed all over the world.

Regarding Spain, electrical generation has traditionally used high polluting sources, like fuel or carbon, or low polluting sources like natural gas. In 2016, electricity generation mix was formed by a 7% of fuel sources, 18% of carbon sources and 17% of natural gas sources. Non-polluting electricity generation sources (nuclear and renewables) represented 57% of all the generation mix. However, renewables had only a weight of 25% of the total mix (“International Energy Agency,” 2018). The necessity of reducing CO<sub>2</sub> emissions together with the recent Spanish policy measures to promote renewable energies have boosted the introduction of higher levels of renewable sources for electricity generation, with the corresponding reduction of high polluting sources (“Red Eléctrica de España | Series estadísticas nacionales,” 2017).

Furthermore, Spain is one of the countries with more solar peak annual hours, so that photovoltaic solar energy could be the most suitable renewable energy to produce large quantities of clean energy (Saiz Jiménez, Hurtado Pérez, & Saiz Melia, 2017). The Spanish regions with the highest number of solar peak annual hours are placed in the south-east of Iberian Peninsula, where vast and wasted desert zones are placed. Hence, using these areas to create big solar photovoltaic fields seems a great solution to generate clean energy.

The aim of this research is to finally calculate if Spain has enough and suitable space to increase solar fields. To this issue, an unrealistic scenario where all the 2017 annual electrical Spanish consumption is covered by solar photovoltaic energy has been studied. Canary Islands and Baleares Islands are not considered in this work, so that only Iberian Peninsula is taken into account.

## **2. Design process**

### **2.1. Solar peak annual hours**

The total quantity of solar photovoltaic energy necessary to cover all the Iberian Peninsula electrical consumption should be calculated considering that the solar fields will be placed in the Spanish regions with highest solar peak annual hours. These communities are the ones located in the south-east of Iberian Peninsula, like Murcia, Almería, Jaén, Granada o

Albacete. It won't be optimal to install them in the Vasc Country or Navarra, for instance (AEMET, 2019).

Moreover, it is necessary to design the installation for the most unfavorable month, being it the one with the highest relation between electrical demand and solar photovoltaic generation. Since the installation will be placed in Iberian Peninsula, this month will be a winter month because it is in this season when solar radiation is lower. For this situation, most suitable annual tilt of solar panels is 60°, so that winter solar gain is facilitated (Bastida Molina, 2016).

Hence, using free software tool PVGIS, it is possible to obtain monthly solar radiation for a 60° tilt for every south-east region of Iberian Peninsula measured in solar peak hours (SPH). With these data, average monthly south-east Spanish regions radiation is calculated.

**Table 1. Iberian Peninsula monthly SPH.**

Month	Murcia	Almería	Jaén	Granada	Albacete	Average
January	154,38	158,41	138,88	149,11	128,34	145,82
February	151,20	162,12	151,20	153,72	140,28	151,70
March	184,76	196,54	180,42	184,45	171,74	183,58
April	161,10	173,10	155,70	156,60	155,40	160,38
May	161,51	165,23	159,65	158,10	155,62	160,02
June	157,20	156,60	159,60	158,70	155,70	157,56
July	170,50	167,71	176,08	174,22	175,15	172,73
August	179,80	182,59	189,41	187,55	181,97	184,26
September	169,80	179,70	177,90	178,80	170,40	175,32
October	173,60	183,21	178,56	185,07	165,85	177,26
November	149,10	157,80	144,00	152,10	132,90	147,18
December	140,43	154,69	136,40	149,42	124,00	140,99

Source: PVGIS (2019).

## 2.2. Electrical demand

The present work is referred to 2017. Monthly real electrical demand of Iberian Peninsula of this year is obtained from (“Red Eléctrica de España | Series estadísticas nacionales,” 2017).

**Table 2. Monthly electrical demand of Iberian Peninsula (GWh)**

Month	Electrical demand
January	23.078
February	19.959
March	21.087
April	18.963
May	20.205
June	21.680
July	22.413
August	21.769
September	20.145
October	20.161
November	20.893
December	22.151

Source: Red Eléctrica Española (2017)

### 2.3. Most unfavorable month choice

Once average monthly SPH (Table 1) and Electrical Demand in 2017 (Table 2) of Iberian Peninsula are determined, it is possible to establish what is the most unfavorable month in terms of energy. This month will be the one with highest relation between electrical demand and solar photovoltaic generation (Bastida Molina, 2016). Average monthly radiation is expressed in SPH, which is equivalent to kWh/m<sup>2</sup>. For having a coherent relation between this parameter and monthly electrical demand, this last term should be expressed in kWh, as Table 3 indicates.

**Table 3. Most unfavorable month choice.**

Month	SPH	Electrical demand (kWh)	Relation
January	145,82	23.078.000.000	158.259.271,45

Source: PVGIS (2018), Red Eléctrica Española (2017) and own elaboration.

Finally, most unfavorable month is January, as Table 3 shows, so that the installation will be designed for this month. On the one hand, it is verified that this month takes place in winter, as previous hypothesis has established. On the other hand, the solar photovoltaic installation

needs to be design for this month, since it is the one with highest and most unsuitable energy conditions.

### 3. Number of solar photovoltaic panels

Considering the month of designing (the most unfavorable in terms of energy), the electrical demand and the SPH of this month, the total number of solar panels to install could be calculated and therefore the total solar photovoltaic power. Designing parameters are summarized in Table 3.

The total initial power of the installation ( $P_i$ ) can be expressed by equation (1), where  $E_d$  represents monthly electrical demand of January and SPH indicates the quantity of solar peak hours of the same month.

$$P_i = \frac{E_d}{SPH} \quad (1)$$

This factor needs to be increased by two more terms (Bastida Molina, Saiz Jiménez, Molina Palomares, & Álvarez Valenzuela, 2017), like equation (2) shows. Hence, final total power of the installation ( $P_f$ ) can be determine.

On the one hand, term  $k_1$  encompasses all the global losses that could occur in the installation and that are all different in nature. Some of these losses could be the reduction of the installation efficiency due to the accumulated dirt on the panels, drops in voltage in wires, differences among fabrication tolerances of the equipments, differences among the operation of the panels... (Lu & Zhao, 2019). A wide span of studies claim that obtaining the exact value of this term turns out to be certainly complicated, since it does not follow a mathematical method and the variability of all the losses that it includes is very diverse (Bastida Molina, 2016; Bastida Molina, Saiz Jiménez, et al., 2017; Bastida Molina, Saiz Jiménez, & Molina Palomares, 2017). These works have quantified this term in 1.2, meaning that initial power of the solar field is increased in a 20%.

On the other hand, term  $k_2$  includes the losses of solar panels due to the test of time. This information should be given by the manufacturer. As standard procedure, panels suffer a lineal decrease of their efficiency due to the test of time of 20% during the firsts 25 years, so that  $k_2$  has a value of 1.2. ("Garantía lineal potencia Módulos Fotovoltaicos Estándar ATERSA," 2013).

$$P_f = P_i \cdot k_1 \cdot k_2 \quad (2)$$

Once total final power of the installation is obtain, it is possible to calculate the quantity of panels ( $N_p$ ) of the solar field in question. To this issue, it is considered that an individual panel has a nominal power of 330 W<sub>p</sub> (Saiz Jiménez et al., 2017). Equation (3) is used to

this aim, where total final power of the installation ( $P_f$ ) and the nominal power of an individual panel ( $P_p$ ) are considered.

$$N_p = \frac{P_f}{P_p} \quad (3)$$

Applying this methodology, it has been possible to know that the solar field in question would ideally be formed by 691million of panels with 228 GW of total power, like Table 4 indicates.

**Table 4. Number of panels and total power of the solar field in question.**

Number of pannels (million)	Total power (GW)
691	228

Source: Own elaboration.

#### 4. Area of the total installation

The total area of the studied solar photovoltaic installation depends on the horizontal area of the solar panel ( $A_h$ ) and the distance to dispose among rows of panels to prevent them from shading ( $d$ ).

Standard dimensions of 330 Wp solar photovoltaic panels are about 1960·40·990· mm (height · width ·length). Moreover, its tilt is also defined ( $60^\circ$ ), as the most unfavorable month in terms of energy is January. Hence, considering both factors, horizontal area of solar photovoltaic panels could be obtained with equation (4), where  $l$  indicates length dimension,  $h$  high dimension and  $t$  represents the tilt.

$$A_h = l \cdot h \cdot \cos(t) \quad (4)$$

This area should also be increased by the area that needs to be provided among rows of panels to prevent them from shadowing (Oh & Park, 2018). The methodology followed to determine the appropriate distance lies in multiplying relative height of the panels by a factor. This factor depends on the latitude of location of the installation, that acquires a value of  $40^\circ$  for Iberian Penninsula. Equation (5) is used to calculate the distance among rows of panels, where  $d$  indicates distance,  $lat$  latitude and  $h$  height.

$$d = \frac{1}{tg(61 - lat)} \cdot h \quad (5)$$

Therefore, the required area among rows of panels to prevent shading ( $A_s$ ) could be obtain by equation (6), where distance ( $d$ ) and length of the panel are considered ( $l$ ).

$$A_s = l \cdot d \quad (6)$$

Finally, considering these two areas, the total area that takes up one individual panel ( $A_p$ ) could be obtain by equation (7). Knowing this value and the total number of solar photovoltaic panels that formed the installation, the total area ( $A_t$ ) that the solar field needs is finally determine by equation (8).

$$A_p = A_h + A_s \quad (7)$$

$$A_t = A_p \cdot N_p \quad (8)$$

Hence, it has been possible to determine the total area that the solar photovoltaic field required to cover all the electrical demand of Iberian Peninsula would take up: 3799 km<sup>2</sup>.

**Table 5. Total area of the solar photovoltaic field in question (km<sup>2</sup>).**

Total area
3799

Source: Own elaboration.

## 5. Conclusions

The uncontrolled quantity of CO<sub>2</sub> emissions that have been emitted to the atmosphere for years have led to a disturbing temperature raise of Planet Earth. A wide span of climate change policies are being developed in almost every country, so that most polluting activities tend to disappear.

Regarding Spain, its electrical generation mix is suffering a transformation, since renewable energies are being introduced. Therefore, with this paper it has been possible to verify that the high number of annual SPH of Spanish Iberian Peninsula (1957) make solar photovoltaic energy an ideal clean energy to generate electricity in this country. Moreover, the unrealistic scenario of covering all the electrical consumption that was really demanded in 2017 with solar photovoltaic energy has been analyzed. Results have proved that the required solar field would take up an area of 3799 km<sup>2</sup>, which only represents a 0.77% of all Iberian Peninsula. South-east regions of Iberian Peninsula are the most suitable ones to place the installation for different reasons. First, these communities are the ones with highest SPH of the Peninsula. Last, large desert zones with no use are located in south-east regions, so installing the solar field there would give use to a previous wasted zone.

To sum up, Iberian Peninsula is likely to increase the percentage of solar photovoltaic energy in the electricity generation mix since it has suitable and enough space to achieve it.

## Acknowledgment

This work was supported in part by the regional public administration of Valencia under the grant ACIF/2018/106.

## References

- AEMET. (2019). *Atlas de radiación solar en España*. Retrieved from [http://www.aemet.es/es/serviciosclimaticos/datosclimatologicos/atlas\\_radiacion\\_solar](http://www.aemet.es/es/serviciosclimaticos/datosclimatologicos/atlas_radiacion_solar)
- Bastida Molina, P. (2016). *Estudio de distintas alternativas fotovoltaicas para alimentación de una instalación*. Retrieved from <https://riunet.upv.es/handle/10251/74582>
- Bastida Molina, P., Saiz Jiménez, J. Á., Molina Palomares, M. P., & Álvarez Valenzuela, B. (2017). Instalaciones solares fotovoltaicas de autoconsumo para pequeñas instalaciones. Aplicación a una nave industrial. *3C Tecnología*, 1–14. <https://doi.org/http://dx.doi.org/10.17993/3ctecno.2017.v6n1e21.1-14>
- Bastida Molina, P., Saiz Jiménez, J. A., & Molina Palomares, P. (2017). *Pequeñas instalaciones alimentadas por sistemas solares de autoconsumo Aplicación a un caso real*.
- Garantía lineal potencia Módulos Fotovoltaicos Estándar ATERSA. (2013). Retrieved December 26, 2018, from <http://www.atersa.com/Common/pdf/atersa/garantias/Garantias-Modulos-Nov13.pdf>
- International Energy Agency. (2018). Retrieved June 28, 2019, from <https://www.iea.org/statistics/electricity/>
- Lu, H., & Zhao, W. (2019). CFD prediction of dust pollution and impact on an isolated ground-mounted solar photovoltaic system. *Renewable Energy*, 131, 829–840. <https://doi.org/10.1016/J.RENENE.2018.07.112>
- Oh, M., & Park, H.-D. (2018). A new algorithm using a pyramid dataset for calculating shadowing in solar potential mapping. *Renewable Energy*, 126, 465–474. <https://doi.org/10.1016/J.RENENE.2018.03.068>
- Red Eléctrica de España | Series estadísticas nacionales. (2017). Retrieved December 26, 2018, from Red Eléctrica Española website: <https://www.ree.es/es/estadisticas-del-sistema-electrico-espanol/series-estadisticas/series-estadisticas-nacionales>
- Saiz Jiménez, J. Á., Hurtado Pérez, E., & Saiz Melia, Á. (2017). “Energía solar fotovoltaica y consumo eléctrico en España.” Retrieved December 26, 2018, from Valencia Plaza website: <https://valenciaplaza.com/energia-solar-fotovoltaica-y-consumo-electrico-en-espana>
- Ziegler, C., Morelli, V., & Fawibe, O. (2019). Climate Change and Underserved Communities. *Physician Assistant Clinics*, 4(1), 203–216. <https://doi.org/10.1016/j.cpha.2018.08.008>

## Examination of sustainable and health-conscious lifestyle among the Hungarian population based on the results of three research studies

Kiss, V.<sup>1</sup>, Balsa-Budai, N.<sup>1</sup>, Soós, M.<sup>1</sup>, Szakály, Z.<sup>1</sup>

<sup>1</sup>Faculty of Economics and Business, Institute of Marketing and Commerce, University of Debrecen, Hungary

---

### **Abstract**

*The implementation of sustainable development and the associated values in consumer behavior is becoming more and more emphasized as well as the increased attention to our health. In both value dimensions, consumer interest is constantly increasing, and the demand for healthy and sustainable products is growing. In our research, this trend was primarily investigated in the field of food consumption. The research was based on the segmentation theory of NMI's LOHAS (Lifestyle of Health and Sustainability).*

*The research consisted of three parts. First, in a nationally representative survey, we examined the commitment of Hungarian adult consumers to the aforementioned values (N = 1000), then high school students (N = 1000), and finally, university students (N = 298) were interviewed on the same topic. In each case, principal component analysis was used to isolate the individual value dimensions and then cluster analysis was used to identify the various segments. In all of the three studies, each group was significantly separated from each other by the values of health consciousness and sustainable development.*

*Based on our results, it can be concluded that the younger age group is more strongly committed to the tested values than the older generation. Consequently, younger generations can be considered a potential consumer market for products and services representing sustainability and health awareness. We believe that further European research on this topic would be useful for both the researchers and the business sector.*

**Keywords:** sustainability, health, consumer behavior, LOHAS

---



## **1. Introduction**

Creating an environment, in which the present and future generations can live and grow in peace and good environmental conditions is a priority for all societies (Kiss et al., 2016).

The challenge of implementing sustainable development at the practical level and taking action is to identify it as a global problem, so it is further away from our individual interests. Numerous studies report that consumers perceive this question as a responsibility of government bodies, companies and not their own (NMI, 2015, Kiss et al., 2018).

In the present study, we have collected research findings, models, and theories that are relevant to the examination of a group that seeks to act as consciously as possible when making consumer decisions, taking into account global issues and personal development. In recent years, there have been several groups identified as having a value dimension associated with one or another issue of sustainable development, namely groups that are environmentally conscious, ethical or ethnocentric. Below, we present the LOHAS (Lifestyle of Health and Sustainability) market segment and its attitudes based on international, Hungarian and our research. (Kiss et al., 2018).

## **2. The Lifestyle of Health and Sustainability segment**

“LOHAS is an umbrella acronym that stands for Lifestyles Of Health And Sustainability. Both for people and the planet it refers to a wide range of industries, corporate activities and products/services that are designed to be environmentally conscious, sustainable, socially responsible, and/or healthier” (French & Rogers, 2015, p. 1). The Natural Marketing Institute was the first to make this segment known worldwide and to do more research to gain a deeper understanding of this segment. Although Baker identified them before 1999, research on the subject started only after 2005. Already in the early years, the LOHAS Group emphasized personal values about “self and about the social and natural worlds”. In addition, they are willing to pay extra for products, which could represent their commitment to these values (Emerich, 2011). The LOHAS Group actively defends its environment and makes its purchasing decisions that way. It takes into account the factors that are best for your own health and that of our planet. They are lifestyle oriented, keeping individual interests in mind. They represent the largest customer group in the green and socially responsible product market (NMI, 2008, Kiss et al., 2018).

Harding (2010) divided the LOHAS market into five segments (Figure 3), and added the importance of Social Justice. In his view, it is along with these values that the most profitable products and services for the LOHAS segment can be created and sold (Kiss et al., 2018).

**Figure 3: LOHAS market**

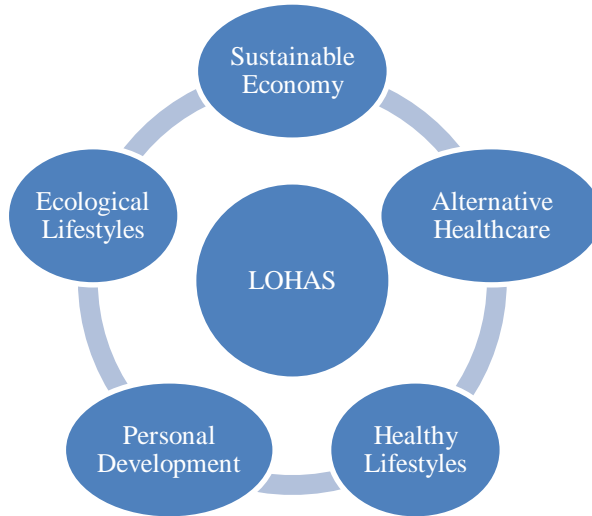

Source: Harding, 2010

However, because of hedonism and its seemingly contradictory values experts question whether the members of LOHAS lifestyle can really be considered the consumer group to achieve the most sustainable consumption. For this reason, we found it necessary to extend our research to another segment as well, which is also dedicated to sustainable consumption (Balsa-Budai – Szakály, 2018).

The segment of voluntary simplifiers, also known as Lifestyle Of Voluntary Simplifiers was identified in the 1930s in America (Gregg, 2003). The representatives of this lifestyle - as the acronym of their name implies - primarily strive to create a simple, sustainable lifestyle where they turn away from materialistic values and the pursuit of maximizing material wealth (Balsa-Budai – Szakály, 2018).

### **3. Materials and methods**

The review of the literature highlighted which values best describe the LOHAS lifestyle. Based on the results of the content analysis of them, a list of statements was made containing 50 elements, 21 of which were analyzed later (Szakály et al, 2017).

For the examinations, two methods were used to make the dimensions of values, and create consumer segments. This study will show significant and eligible results only.

The first examination is based on a nationally representative questionnaire. The survey was carried out in Hungary in 2014, involving 1000 people. Representativeness, regions and settlement types are provided by the quota sampling method (Szakály et al., 2017).

The aim of the second examination was to examine the conscious consumer and health behaviour on a sample representative of the sex and age of the population of Hungarian secondary school students (n=1001) (Kiss et al, 2016).

The third study focused on university students' opinions, it was based on a non-representative survey which involved 298 people. (Budai – Szakály, 2018).

#### **4. Results of our research studies**

Over the past five years, we have conducted four pieces of research on the LOHAS segment. Three of them will be introduced here. We examined the Hungarian adult population, Hungarian university students and Hungarian high school students.

##### **3.1. Findings on Hungarian adults**

Based on the results five value-based segments can be distinguished. These segments were the Young Trend Followers, the Ethical Traditionalists, the Young Environmentally Conscious People, the Uninvolved Elderly People and the Disappointed Pessimists. The biggest cluster was the Young Trend Followers and this group reflects the characteristics of the LOHAS consumer lifestyle to the greatest extent. However, this segment cannot be considered as a fully engaged consumer group by LOHAS values, so further segmentation of this group was needed. As a result of this the third subgroup of this further segmentation emphasizes ethical competence and most claims are identified by the LOHAS consumer group. This segment accounts for 8.7% of the Hungarian population. Further research is needed to determine similarities in value orientation with other Eastern European countries, where the social and cultural background is very similar to Hungary and to compare Hungary with western countries to discover differences in consumer attitudes (Szakály et al., 2017).

##### **4.2. Findings on university students**

In the examination of university students, with factor analysis six value dimensions were defined. They are as follows: the health conscious, the sustainable development, the social, the product-oriented, the traditionalist and the individualist. Based on the dimensions four segments were created by K-means cluster analysis. These were the Ambitious Trendfollowers, the Conscious Simplifiers, the Traditional Individualists, the Health Conscious people. In the case of the LOHAS consumer group, the Ambitious Trend Followers (the cluster size was 25.1% of the students asked) reflect the characteristics of the LOHAS consumers' lifestyle to the greatest extent. In the case of the LOVOS consumer

group, the most dedicated cluster was the Conscious Simplifiers (the cluster size was 34.55% of the students asked). However, this segment does not entirely reflect all the values of the LOVOS consumers' lifestyle, so further research is necessary in the future (Balsa-Budai – Szakály, 2018).

### **4.3. Secondary school pupils' attitudes to health and sustainability**

For the examination of the youngest group, the principal component analysis was used, which could discover five value dimension which was similar to the findings on adults. These were as follows: the trendy individualist, the health and environmentally conscious, the authentic patriot, the altruist ethical and the follower of firm ethical behavior. With them, we could determine four segments with K-means cluster analysis. The segments were named as Conscious trend avoiders (who could be similar to Conscious Simplifiers), Responsibility Avoiders, Passive first-year pupils and Conscious individualists (who can be identified as the LOHAS group).

## **Discussion**

As discussed earlier, the implementation of sustainable development and the associated values in consumer behavior is becoming more and more important as well as our health. In both value dimensions, consumer interest is constantly increasing, and the demand for healthy and sustainable products is growing.

In our research, we have explored the Hungarian conscious segments, and this knowledge is useful for companies and the state. Further international research would provide an opportunity to discover and compare global and local needs and attitudes and to better understand the market opportunities of conscious lifestyles.

## **References**

- Balsa-Budai, N. & Szakály, Z. (2018): A fenntartható értékrend vizsgálata debreceni egyetemisták körében (The investigation of sustainable values among the students of the University of Debrecen). *Táplálkozásmarketing (The Hungarian Journal of Nutrition Marketing)*, 5(1), 3-20.
- Kiss, V. A., Kiss, M., Popovics, P. & Szakály, Z. (2018): Examination of Lifestyle of Health and Sustainability market groups with particular focus on Hungary. In: Gazdecki, M. – Gorynska-Goldmann, E. (eds.) *Relationships on Food Markets – Consumers' perspective*. Poznan University of Life Sciences.

....

## Shaping future research agenda on sustainability research within the CARPE network

Erlijn Eweg<sup>1</sup>, Martijn Rietbergen<sup>2</sup>

<sup>1,2</sup>Research Center Healthy and Sustainable Living, University of Applied Science Utrecht, The Netherlands

---

### **Abstract**

*Within the involved Higher Education Institutes of the CARPE network, many research groups are working on sustainability related topics. However, the expertise of these research groups are not fully exploited if it comes to acquiring new opportunities for externally funded research projects. This proposed project aims at developing a research community among CARPE partners involved in sustainability research, to shape a joint future research agenda on sustainability research, and to explore how to get the most benefits out of our cooperation.*

**Keywords:** Sustainability; cooperation; research; community (maximum 6).

---

---

<sup>1</sup> erlijn.eweg@hu.nl

<sup>2</sup> martijn.rietbergen@hu.nl

## **1. Introduction**

CARPE was founded in November 2011. A CARPE university conducts research and provides education that is demand-driven and which contributes to innovation of the professional practice; with strong links to small and medium enterprises (SMEs), large enterprises, the public sector and local and regional governments. Over the last years CARPE colleagues have been offered several opportunities to learn about mutual interests and expertise's (e.g. at CARPE conferences and workshops), leading to a consolidation of the consortium and having teachers, researchers and support staff feel closely linked with CARPE partners. The CARPE partners aimed to encourage cooperation in European research programs, jointly develop educational programmes and exchange students and staff and many times with success.

## **2. CARPE and sustainability**

Since the beginning of the 21st century the majority of the world population lives in urban areas. This urbanization poses important challenges for cities of the future: how do we solve the problems related to energy mobility and waste? And how can we solve that in a smart way, for example with the help of ICT? The future of human mankind depends to a great extent on whether we will be able to boost the sustainable development of cities. All CARPE university embrace the topic of sustainability in their own urban living environments. *The main question that we like to explore is if our cooperation can be further strengthened (organized) aiming at developing integrated sustainable solutions for economic, social and environmental problems in urban areas in various European regions.*

### **2.1. The experience so far**

At the CARPE conferences, and as an outcome of the cooperation in the former IP (Intensive Programme) project ISA (International Sustainable Architecture), awareness was risen among the CARPE partners that an integral approach to realize sustainable cities is needed and that the best results can only be reached in tight cooperation with our stakeholders, the municipalities or local authorities or companies. Different disciplines have to work together to tackle the challenges, for example disciplines like Built Environment, Engineering, Urban Development, but also concerning Creative Engineering, Design, Economics, Socials, Community, Governance and Incubator Facilities. As follow up on ISA, in 2014 a strategic partnership was developed, the so called ESSENCE project, about European Sustainable solutions for Existing and New City Environments. The subject of ESSENCE was to develop sustainable solutions for existing and new city environments. Although the project ended in 2016, jointly developed learning material is still in use by various partners of this project. A

minor programme on smart sustainable cities is yearly offered by HU Utrecht, with participation of teaching staff from Hamburg, Turku, Valencia and Manchester.

As a follow up of this cooperation, another Erasmus project was started, a Capacity Building project called SAUNAC, meaning: Sustainability Alliance of Urban Networks in Asian Cities. This Capacity Building project aimed to increase employability, skills for new business creation, active participation of young people in society and sense of initiative and (social) entrepreneurship especially concerning environmental awareness. Through opportunities for learning mobility and joint efforts from education to societal challenges the competences/skills regarding the contribution to society and environment were improved. Both projects did give answers to one key issue on the EU's agenda for change: "... a greater focus on investing in drivers for inclusive and sustainable economic growth..."<sup>1</sup> With the international dimension of education and training, we could promote diversity and intercultural awareness especially for sustainable urban areas.

Apart of the activities above, each CARPE university contributes to the subject of sustainability by preparing Open courses, based on their specific expertise and interest in the course topics (people, planet, profit, methods, and projects). Until now we have seen that the CARPE partners bring in expertise knowledge on the following specific competences, as shown below:

- HU: Social innovation, co-design, blended learning approaches, sustainable renovation, policy regulations, city design; healthy living effects of sustainability, energy systems;
- UPV: Building integrated modeling, materials integration, construction technology systems, and landscape design & green infrastructure;
- HAW: Logistics and transport, smart grids, electric transport, ICT, climate adaptation;
- MMU: Future cities, Eco-innovation, business models for sustainable energy, facilitating entrepreneurial activities;
- TURKU: Water in the cities, energy in the cities, environment & wellbeing in the city; circularity.
- Debrecen: Health in relation to pollution, water management, linguistics

## 2.2. Bottlenecks

In our cooperation we notice some bottlenecks that affect the success of our cooperation. First, we identified that in the cooperation nowadays, we often depend on actual calls for funding of our activities. And it might be that reacting on opportunities, is not always the best

strategy to be successful. Second, we do not know whether these subjects /calls are in line with the strategic choices of each university. At the moment we cannot oversee whether these subjects do correspond only to the involvement of certain active research groups, or do they correspond with the specialism of the university? Third, cooperation has often not been formalized, and depends on good will of individuals. E.g. the minor Smart Sustainable Cities in the Netherlands has to be organized each year again, and depends on guest speakers from other CARPE universities, and the opportunities for student research projects abroad. Better knowledge of the specialisms of each other, better alignment of the research within the Carpe partners, could be an interesting approach to start with. As the rector from UPV explains “*If we want to turn them [the proposals] into successful initiatives, we need to work together within support structures that benefit our projects and make them stand out in today’s highly competitive environment*”<sup>ii</sup>.

### **3. The future challenge for CARPE**

Resuming, we can conclude that the development of integrated sustainable solutions for economic, social and environment challenges in urban areas is demanded. Over the last decades important geographical, demographical and environmental changes have taken place in the urban environment. The rate of urbanization increases rapidly, urban population is increasingly ageing and environmental pressures in especially urban areas are growing. The need for a transition towards more sustainable cities requires a reinforcement of academic programs that educate professionals able to develop viable solutions for smart sustainable cities. By our experiences we think that our knowledge and expertise on societal challenges will improve the quality of possible solutions with impact on regional societies, as a result of the cooperation between CARPE partners (universities) and national, regional and local government. The need for these solutions are underlined also by the European Commission <sup>iii</sup>: “*Higher education is at the heart of Europe’s ambition to become a smart, sustainable and inclusive economy: it plays a crucial role in individual and societal advancement; and, with its impact on innovation and research, it provides the highly skilled human capital that knowledge-based economies need to generate growth and prosperity.*”

#### **3.1 CARPE research**

In the context of urban-societal needs we have to form an integral approach to obtain sustainable cities, with involvement of national, regional and especially municipal governments, whose important role in setting a vision for sustainable cities was appointed already in Rio 20+ (art. 136 RIO 20+ decisions). The shared vision on sustainable cities between HEIs and authorities is essential for the cooperation on smart sustainable cities. The participating organizations can learn from each other’s approaches and we have to learn to work better together on societal challenges in the new cultural environment with innovative



approaches. Collaborative learning within CARPE on Smart Sustainable Cities can be left up to a next phase of development: building a community of research and practice, a system for peer feedback and preserving knowledge gained in projects. We like to explore 3 subjects with you during the conference in Valencia, October 2019, to resolve the former mentioned bottlenecks:

- Can the development of a community of practice and research, or even a joint research center on Smart Sustainable Cities be helpful to us?
- Is working on a joint future research agenda interesting to offer us more understanding of the research subjects and specialism of each CARPE partner? And in the case that we are able to make a start with a joint agenda, will this be helpful to make our impact more visible in Europe, or even more visible in European policy on applied research?
- And finally, can COST be an interesting call to realize this ideas, starting with urban –societal needs to obtain sustainable cities?

### ***3.2 Potential source of funding***

One potential source of funding might be the European Cooperation in Science & Technology – COST ([www.cost.eu](http://www.cost.eu)). COST provides international research funding for researchers to set up their interdisciplinary research networks in Europe and beyond. COST provides funds for organizing meetings, training schools, short term scientific missions or other networking activities. Our suggestion for the cooperation in a COST project aims at developing a more intensive and structural cooperation of research communities among CARPE partners involved in sustainability research, to shape a joint future research agenda on sustainability research, and to acquire new funds effectively.

### ***References:***

---

<sup>i</sup> “*Increasing the impact of EU Development Policy: An Agenda for change*”.

Communication from the Commission to the European Parliament, the Council, the European Economic and Social Committee and the Committee of the Regions, Brussels, 13.10.2011, COM(2011) 637 final

<sup>ii</sup> “*Let’s maintain strong links*” – Carpe- a European network of Universities of Applied Sciences. 7.2018 page 3.

<sup>iii</sup> “*European Higher Education in the World*”. The commission to the European parliament - Brussels 11.7.2013 COM 499 final

## Supporting an European Up-scaling of Net Zero Energy House renovations

Rogier Laterveer<sup>1</sup>

<sup>1</sup>HU University of Applied Sciences Utrecht, The Netherlands.

---

### **Abstract**

*Upscaling technologies for Net Zero Energy buildings in the built environment and particular in the construction industry is a challenge that a few companies in the Netherlands can take on. But what does it take to up-scale technology to facilitate a broader transition in the European Union to meet the climate goals? We need knowledge about our customers and the designs that connect to their needs. But we also need to know in what kind of houses people live. Especially the technical state of these houses and where these houses are located. We find that the knowledge of how houses and apartment buildings are actually built is lacking and not connected on a European level. The knowledge is crucial to the companies whom face the risks of designing product systems (project independent) and find that the designs won't fit the houses they apply them on. This means the companies and investors will not invest descent amounts of money in the production facilities and thus scaling production to normal amounts of products is lacking.*

*So we need a lot of specific data that connects to the needs of companies so they know how to (re)design product families to be produces for a wide variety of markets. A diverse and perceived difficult to handle stakeholder in this is the private house owner, but also there seems to be a lack in knowledge with company owned houses about the technical state. To get data on the materials of houses (apartments and houses) it creates also a material library for future purposes and if in te future the data is connected to a BIM and GEO model it can be updated and extended with new added technologies.*

*This research tries to engage Secondary Vocational Education, Universities of Applied Sciences and Universities in general to collaborate in harvesting crucial data about houses throughout Europe for the energy transition.*

**Keywords:** *European Housing Stock; Net Zero Energy; Renovation; Retrofit; Up-Scaling; Building Technology.*

---

This paper has been submitted for publication in a scientific journal.

## **Enhancing cooperation between HEIs and Companies in South East Asia to accelerate sustainable business opportunities**

**Martijn Rietbergen<sup>1</sup>, Erlijn Eweg<sup>2</sup>**

<sup>1,2</sup>Research Center Healthy and Sustainable Living, University of Applied Science Utrecht, The Netherlands

---

### ***Abstract***

*This proposed project builds forth on the still ongoing ERASMUS+ capacity building project “Sustainability Alliance of Urban Networks in Asian Cities” (SAUNAC). SAUNAC, amongst others, aimed at designing, implementing and evaluating educational programs on Smart Sustainable Cities at Vietnamese universities. This new proposed project takes SAUNAC to a next level, by further developing the cooperation in the quadruple helix, especially between Higher Education Institutes on the one hand and Companies active in Vietnam on the other hand. This requires additional efforts to tuning of (degree) programmes with competences required by businesses. The target group of companies / HEIs are active in the field of sustainable development.*

***Keywords:*** Funding: Erasmus+ Capacity Building.

---

## **1. Introduction**

The past three years the CARPE consortium (led by the Turku University of Applied Science) run the ERASMUS+ capacity building project “Sustainability Alliance of Urban Networks in Asian Cities” (SAUNAC). SAUNAC, amongst others, aimed at designing, implementing and evaluating educational programs on Smart Sustainable Cities at Vietnamese universities. Since the SAUNAC project is coming to an end soon, we should think about further exploiting the results of the project: meaningful impacts have been achieved if it comes to an active learning approach, an intensive network with a wide variety of stakeholders has been developed, and an integrated approach to urban sustainable development has been preached. In addition, a wide range of opportunities for a potential follow-up project have been brought up. This paper briefly introduces the SAUNAC project (section 2), identifies opportunities, topics or ideas for a follow-up project (section 3), proposes a potential source of funding (section 4), and finalizes with a wrap up (section 5).

## **2. The project “Sustainability Alliance of Urban Networks in Asian Cities”**

This document could be used as a template for formatting the papers. All texts, figures and tables must be included within the document margins.

### **2.1. SAUNAC consortium**

Sustainability Alliance of Urban Networks in Asian Cities (SAUNAC) is an ERASMUS+ KA2 Capacity Building project running from 2016 - 2019. The project is a collaboration between higher education institutions from Europe and Vietnam. The European partner Universities include the following members of the Consortium on Applied Research and Professional Education (CARPE): Turku University of Applied Sciences (Finland), University of Applied Science Utrecht (Netherlands), the Universitat Politècnica de València (Spain), Manchester Metropolitan University (UK), and the Hamburg University of Applied Sciences (Germany). The partner Universities in Vietnam are the Hanoi University of Civil Engineering, the Danang University of Science and Technology, the Ho Chi Minh City University of Natural Resources and Environment, the Vietnam National University, the Haiphong University, and the Hue University of Sciences.

## **2.2. SAUNAC project goals**

The SAUNAC project focuses on the following objectives: 1) accelerating the design, development and acceptance of viable solutions for sustainable cities in Vietnam; 2) the development of a joint course on the design of sustainable cities in Vietnam; 3) the exchange of best practices of innovative educational approaches; and 4) the strengthening of the triple helix network in Vietnam.

## **2.3. Main activities in the SAUNAC project**

A wide range of activities have been carried in the SAUNAC project. First of all a couple of train-the-trainer sessions have been carried to learn Vietnamese teacher how to use active learning methods, blended learning techniques and co-design techniques in their education. Second, much efforts were put in designing modules on various topics on Smart Sustainable Cities in a Vietnamese context. Third, these modules were piloted at different universities. The applied research projects for students was considered as highlight that condensed many aspects of the SAUNAC project. Fourth, a couple of conferences were organized to disseminate the results of the project. Fifth, stakeholder engagement was a central theme as well the enhance the cooperation between partners in the triple helix. Sixth, the project also focused on further exploitation of project results, e.g. developing further cooperation between involved project partners.

## **3. Future Challenges**

Based on the experiences in the SAUNAC project we identify a couple of opportunities, ideas or topics that a follow up project could focus on. These topics are ‘Increasing impact by introducing Leadership training’, ‘Triple Helix cooperation’, ‘increased mutual benefits’ and ‘Corporate Social Responsibility’.

### **3.1. Increasing impact by introducing Leadership training**

Based on earlier experience in the SAUNAC project, we identified an implicit need to introduce some sort of leadership training (or similar type of ideas, such as champions within university, ambassadors for change, change agents, etc.) that could facilitate ‘change’ for modernization of the educational system more effectively. As Knuutila & Lappalainen (2018) stated, the educational system is modernizing slowly; ‘a transformation from a hierarchic teacher-centered learning culture towards student-centered learning takes time’. Therefore, there is a need for forerunners. The concept of ‘Leadership in the classroom, in school and in the community’, by ‘Teach for Vietnam’ initiative, is an interesting approach that we could built upon in a future project.

### **3.2. Triple Helix cooperation**

The triple helix of innovation-driven economic growth conceptualizes the cooperation between universities, governments and industries. Universities have a pivotal role in driving innovation. Despite small steps have been made to *enhance cooperation in this triple helix*, universities are still often acting traditionally (communicating knowledge) rather than teaching critical thinking, promoting entrepreneurial skills and getting engaged in demand driven activities (Baark, 2016). Furthermore, companies could play a much important role in modernizing education, e.g. helping to introduce competence based education, doing applied research, providing internship opportunities, etc. Governments should play a facilitating role in innovation, e.g. by providing the right policies, measures and laws. The quadruple helix module is an extension of the triple helix model in which citizens, local communities or societal interest groups are also added. Since the role of consumers (users) is critical in the development of Smart Sustainable Cities, we suggest to use quadruple helix model in future projects.

### **3.3 Increased mutual benefits**

A long term cooperation between European and Vietnamese universities will only last if there are mutual benefits. Up till now, the benefits for European partners are primarily related to extending their project portfolio to Asia, increasing their network with Vietnamese universities, promoting their research and educational activities abroad. For the longer term it is very important that European partners should utilize these type of projects better, e.g. for acquiring funded research projects, enhanced student exchange and supporting local / regional European companies with accelerating their business opportunities in Vietnam. Therefore, the involvement of local European companies in a future project might add value significantly, both for student, university and company.

### **3.4 Corporate Social Responsibility / Sustainable growth**

The concept of corporate social responsibility (CSR) has been implemented widely among firms in Europe. CSR means that the company has procedures in place of that balances the impact of its business activities on people, the environment and their business operations. According to Phan Van Thanh & Szilárd Podruzsik (2018) the implementation of the CSR concept in Vietnam is still limited. In a developing country like Vietnam, it is however of great interest that companies in order to grow sustainably, should adhere to the sustainable development principles like environmental protection, equality, inclusiveness, safety, talent management, community growth etc.

#### **4. Realizing new ideas**

One of the potential sources of funding is the ERASMUS+ Key Action 2 on Capacity Building in the field of Higher Education (CBHE), see EC (2019). The CBHE promote cooperation and partnerships that have an impact on the modernization and internationalization of higher education institutions and systems in Partner Countries, such as Vietnam. Projects have a typical size of around 900.000 euros. The budget for CBHE in Region 6 countries (including Vietnam) was around 48 million in 2018. One of the defined priority theme in Asia region 6 is the cooperation between Higher Education Institutes and Business.

#### **5. Wrap-up**

The SAUNAC ERASMUS+ KA2 Capacity Building project is a collaboration between higher education institutions from Europe and Vietnam. It primarily aims at designing, implementing and evaluating educational programs on Smart Sustainable Cities at Vietnamese universities. A wide range of opportunities arise to further exploit the results of this project. A future project could combine a set of various topics that have been identified such as 1) increasing the mutual benefits (by increasing the role of European companies in the project); 2) further intensification of cooperation in the triple helix; 3) develop leadership trainings; 4) corporate social responsibility / smart sustainable cities. The central theme of a future project could be ‘enhancing the cooperation between HEIs and Companies in South East Asia to accelerate sustainable business opportunities modernizing (degree) programmes’. At the conference we would like to discuss these opportunities in more detail, identify additional ideas, exchange experiences on working in Asian countries, and investigate future cooperation.

#### **References**

Rietbergen, M.G., E. De la Poza, J. Orozco-Messana (2018). Designing a programme for Sustainability in Vietnam: Smart Sustainable Vietnamese Cities, SSVC. 4th International Conference on Higher Education Advances (HEAD'18) Universitat Politècnica de València, Valencia, 2018.

EC (2019). Erasmus+ Programme Guide – version 2 2019. European Commission

Lehmann, S., F. Schubert, I. Herrmann, P Vuthi (2017). Sustainability Alliance of Urban Networks in Asian Cities (SAUNAC) – a Project Overview. Fakultät Technik und Informatik Department Informations- und Elektrotechnik – E-Forum.

Le Hieu Hoc, (2019). University–Industry Linkages in Promoting Technology Transfer: A Study of Vietnamese Technical and Engineering Universities. *Science, technology and Society* 23(1), 73-100.

Baark, E. (2016). Innovation System Reform in Indonesia and Vietnam: A New Role for Universities? *Journal of STI Policy and Management* 1(1) 1-15.

Knuutila, H., H. Lappilainen (2018). Modernizing Vietnamese sustainable development education – case study of SAUNAC project. Paper presented at the conference on ‘scientific and management solution for effective use of natural resources and energy towards sustainable development and climate change adaptation’. 29 November 2018, Ho Chi Min City, Vietnam.

Phan Van Thanh, Szilárd Podruzsik (2018). CSR in Developing Countries: Case Study in Vietnam. *Management* 13 (4): 287–300.



## Life Cycle Sustainability Analysis for Circular Economy

Vanesa G. Lo Iacono Ferreira<sup>1</sup>, Juan Ignacio Torregrosa López<sup>1</sup>

<sup>1</sup>Department of Chemical and Nuclear Engineering, Higher Polytechnic School of Alcoi (UPV), Spain.

---

### **Abstract**

*A Life-Cycle Sustainability Analysis is a complex assessment that requires time, expertise and quality data. Decision-making boards of industries required live data to manage their business. Although planned changes can be made pursuing innovation and sustainability within a wide timeframe, daily decisions are often driven just by economic indicators. However, many industries are already implementing systems, simple or complex, that allow them to obtain some environmental or social information related to their activities aware that not only economic value fosters the circular economy that our planet needs.*

*Key performance indicators are excellent information suppliers that can be defined either in the economic, social or environmental areas of a sustainable analysis. Willing to develop a methodology easy to apply in existing decision-making panels that incorporate social and environmental indicators to fill the gap of sustainability analysis, this research group is exploring new protocols and procedures to define customized key performance indicators. The inclusion of key performance indicators based on Life Cycle Assessment in existing management panels will serve as a tool to make the commitment of our European industries with a circular economy come true.*

**Keywords:** *sustainability life cycle assessment.*

---

## **1. Introduction**

The European Commission is promoting projects with a high level of readiness to make the needed transition of organizations (including industries) into the Circular Economy easier and faster. A recent topic under the Nanotechnology, Advanced Materials, Biotechnology, and Advanced Manufacturing and Processing funding program has been released. This call is looking to develop methodologies to incorporate social and economic indicators in sustainability evaluation with a high level of readiness.

This article draws the framework of a project proposal seeking to develop a quantitative approach that allows assessment of the sustainability multicriteria trade-off of circularity dynamically in real cases (cradle to cradle). The goal is to facilitate the incorporation of existing products harmonized approach with a public demonstration where it is imperative to work with industrial associations and clusters to engage with industry, SMEs, consumers, standardization bodies and the rest of stakeholders.

Before presenting the methodology proposal, the three main concepts fundamental pillars of these project are shortly described.

### ***1.1. Life Cycle Sustainability Assessment***

Life Cycle Assessment (LCA) is a tool to assess the environmental impact of products, services or organizations over all their life cycles. It is well documented and widely applied following recognized standards (International Organization for Standardization, 2006a; 2006b). LCA is one of the most accepted tools for the study and measurement of environmental impacts related to products and services and, since de last 5 years, also to organizations. LCA gives detailed information regarding all the environmental impacts of the product that helps both the understanding of the environmental performance and comparison between different products. It is essential when applying eco-design. Choosing the best materials implies having enough information regarding its economic value, technical and environmental performance. However, an LCA requires a significant amount of resources and time that makes it difficult to implement in a decision-making process at an organizational management level (Lo-Iacono-Ferreira et al., 2016).

Although environmental impacts are relevant, there are two other aspects essential for sustainability. The integration of social and economic benefits with environmental burdens results in a true Life Cycle Sustainability Assessment.

### **1.2. Key Performance Indicators**

The main tool that management boards use are the Key Performance Indicators (KPI). These indicators are, traditionally, economic and financial indicators related to critical factors (Kerzner, 2011; Parmenter, 2015). KPIs are defined by:

- finding the organization's operational critical success factors
- determining measures that will work in the organization
- getting the measures to drive performance

Identifying the relevant values for an organization is the first step in any KPI definition process. The definition and implementation in operational and management boards of KPI environmentally-related are not frequent. However, more and more complex organizations are investing in projects to define environmental and social KPIs in order to apply them as management and operational tools for everyday decision-making (Lo-Iacono-Ferreira et al., 2018).

There are different techniques where it can be highlighted the exploratory factor analysis and the structural equation modeling. Recognized authors as Vachon and Klassen (2006, 2008), Govindan et al. (2015) and Nejati and Nejati (2013) have explored statistical methodologies as the exploratory factor analysis to identify relevant variables. It is a frequent complementary tool of sustainability analysis of supply chains, certification processes and sustainability factors of universities. Structural equation modeling has been used in environmental performance assessment of small and medium-size manufacturers (Hussey and Eagan, 2007).

### **1.3. Circular Economy**

Circular Economy is the framework needed to ensure sustainability. It is a hot topic in the industry and the R+D+i environments (Urbinati, A. et al., 2017). It is based on three principles:

1. design out waste and pollution
2. keep products and materials in use
3. regenerate natural systems

Re-thinking and re-designing the processes used in production and services is the key to preserve materials and energy as designing new products and materials with this vision. It is a new approach where the concept closed-loop economy and cradle-to-cradle have full attention (McDonough and Braungart, 2002; Murray et al., 2017). To achieve the efficient loop of products (maintaining them as long as possible as useful material)

Linder and Williander (2015), Vermeulen (2015) and Crainer (2013) have already explored the Circular Economy as a paradigma that organizations can implement form a business

model point of view. The traditional life cycle needs to change to something new and tridimensional (Figure 1), where it is no longer a circle but a sphere with different paths that a product or material can take depending on its characteristics and the needs of the system to close the loop (Korhonen et al., 2018).

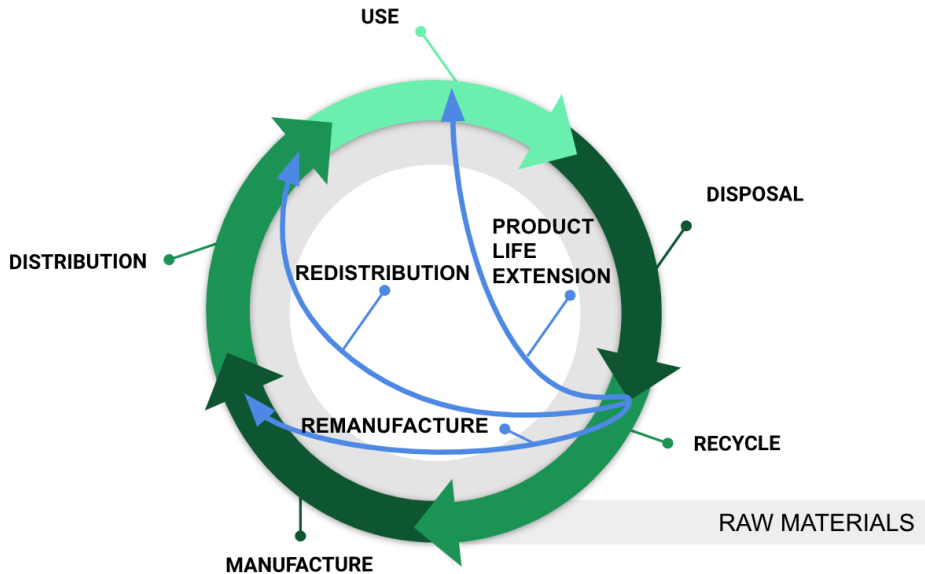

*Figure 1. Spheric life cycle.*

## **2. Methodology proposal**

The context of an organization is complex; different stakeholders are involved and external and internal influences required attention. To ensure a successful result for the project, the methodology developed by the European Commission (2010) plan-do-check-act (PDCA) methodology is proposed (Figure 2). The context will be first defined followed by the goals and scope. Stakeholders, internal and external influences will be analyzed to identify risks and opportunities. Then, the wheel will start moving from plan to do, checking to verify results and acting to improve the performance of the tool developed to continue with the circle.

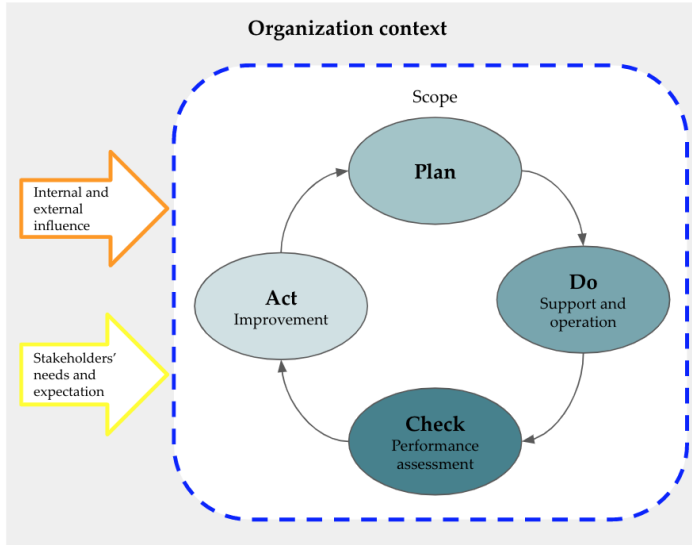

Figure 2. PDCA

To design the tool based on KPIs a proven methodology in complex organizations (Lo-Iacono-Ferreira et al., 2018) is proposed. The methodology is based on a continuous improvement system where stakeholders participants in the first stages and the system is validated in situ with real data (Figure 3).

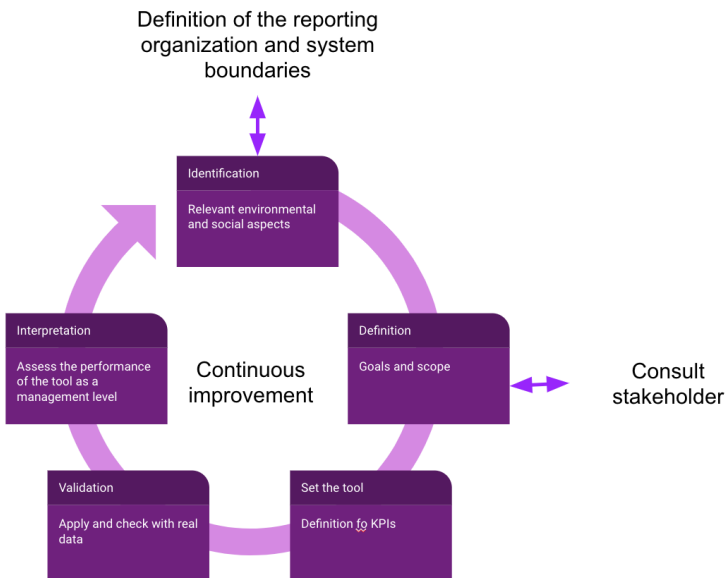

Figure 3. Continuous improvement methods.

### **3. Our project, conclusions, and goals**

The European Commission and many of the European countries are promoting the paradigm change to drive Circular Economy. An early-stage sustainability evaluation tool that allows increasing the consistency across sectors through value chains is needed. Decision-makers need to be better informed to design and develop future products and processes through improving the visualization and communication of potential sustainability trade-offs with stakeholders.

Through this project, new business opportunities will be highlighted and the competitiveness of European industries will be increased; SMEs will be able to access new support in the transition to the circular and sustainable economy.

We have wide experience in sustainability assessment with experimental proof of new concepts and validation in relevant environments. Life Cycle Assessment and Key Performance Indicators in complex organizations and city management are our specialties. We have the opportunity to improve product investment toward the Circular Economy by forming a consortium of researchers, technology developers, and organizations that provide real data allowing the definition KPIs in the management system of industries.

### **References**

- Crainer, S., (2013) Squaring the circle. *Bus. Strategy Rev.* 24 (4), 13-19. <https://doi.org/10.1111/j.1467-8616.2013.00988.x>
- European Commission - Joint Research Centre - Institute for Environment and Sustainability: International Reference Life Cycle Data System (ILCD) Handbook - General guide for Life Cycle Assessment - Detailed guidance. First edition March 2010. EUR 24708 EN. Luxembourg. Publications Office of the European Union; 2010
- Govindan, k., Rajendran, S., Sarkis, J., Murugesan, P., (2015) Multi criteria decision making approaches from Green supplier evaluation and selection: a literature review. *J. Clean. Prod.* 98, 66-83. <https://doi.org/10.1016/j.jclepro.2013.06.046>.
- Hussey, D.M., Eagan, P.D., (2007) Using structural equation modeling to test environmental performance in small and medium-size manufacturers: can SEM help SMEs? *J. Clean. Prod.* 15 (4), 303-312. <https://doi.org/10.1016/j.jclepro.2005.12.002>.
- International Organization for Standardization (2006a) Environmental Management Life Cycle Assessment e Principles and Framework. ISO 14040:2006.
- International Organization for Standardization (2006b) Environmental Management Life Cycle Assessment e Requirements and Guidelines. ISO 14044:2006(E).
- Kerzner, H.R., (2011) Project Management Metrics, KPIs, and Dashboards: a Guide to Measuring and Monitoring Project Performance. John Wiley & Sons. <https://doi.org/10.1002/9781118086254>

- Korhonen, J., Nuur, C., Feldmann, A., Birkie, S.E. (2018) Circular economy as an essentially contested concept. *J. Clean. Prod.* 175, 544-552. <https://doi.org/10.1016/j.jclepro.2017.12.111>
- Linder, M., Williander, M., (2015) Circular business model innovation: inherent uncertainties. *Bus. Strategy Environ.* 26 (2), 182-196. <https://doi.org/10.1002/bse.1906>
- Lo-Iacono-Ferreira, V.G., Capuz-Rizo, S.F., Torregrosa-López, J.I. (2018) Key Performance Indicators to optimize the environmental performance of Higher Education Institutions with environmental management system - A case study of Universitat Politècnica de València. *Journal of Cleaner Production*, 178, 846-865. <https://doi.org/10.1016/j.jclepro.2017.12.184>
- Lo-Iacono-Ferreira, V.G., Torregrosa-López, J.I., Capuz-Rizo, S.F. (2016) Use of Life Cycle Assessment methodology in the analysis of Ecological Footprint Assessment results to evaluate the environmental performance of universities. *Journal of Cleaner Production*, 133, 43-53. <https://doi.org/10.1016/j.jclepro.2016.05.046>
- McDonough, W., Braungart, M., (2002) *Cradle to Cradle: Remaking the Way We Make Things*. New York: North Point.
- Murray, A., Skene, K., Haynes, K., (2017) The circular economy: an interdisciplinary exploration of the concept and application in a global context. *J. Bus. Ethics* 140 (3), 369-380. <https://doi.org/10.1007%2Fs10551-015-2693-2>
- Nejati, M., Nejati, M., (2013) Assessment of sustainable university factors from perspective of university students. *J. Clean. Prod.* 48, 101e107. <https://doi.org/10.1016/j.jclepro.2012.09.006>
- Parmenter, D., (2015) *Key Performance Indicators: Developing, Implementing, and Using Winning KPIs*. Jhon Wiles & Sons.
- Urbinati, A., Chiaroni, D., Chiesa, V., (2017) Towards a new taxonomy of circular economy business models. *J. Clean. Prod.* 168, 487-498. <https://doi.org/10.1016/j.jclepro.2017.09.047>
- Vachon, S., Klassen, R.D., (2006) Green project partnership in the supply chain: the case of the package printing industry. *J. Clean. Prod.* 14, 661-671. <https://doi.org/10.1016/j.jclepro.2005.07.014>
- Vachon, S., Mao, Z., (2008) Linking supply chain strength to sustainable development: a country-level analysis. *J. Clean. Prod.* 16, 1552-1560. <https://doi.org/10.1016/j.jclepro.2008.04.012>
- Vermeulen, W.J., (2015) Self-governance for sustainable global supply chains: can it deliver the impacts needed? *Bus. Strategy Environ.* 24 (2), 73-85. <https://doi.org/10.1002/bse.1804>

## Currently Known Characteristics of Bat Species Represented in Hamburg in Respect of Wind Turbine Casualties

Polina Krapivnitckaia<sup>1</sup>, Veit Dominik Kunz<sup>2</sup>, Carolin Floeter<sup>3</sup>

<sup>1</sup>CC4E/Energy Campus, Hamburg University of Applied Sciences, Germany, <sup>2</sup>Department of Process Engineering, Hamburg University of Applied Sciences, Germany, <sup>3</sup>Department of Environmental Engineering, Hamburg University of Applied Sciences, Germany

---

### **Abstract**

*Bats are animals protected by the law, however many become wind turbine related casualties. To estimate the risk from wind turbines, a systematic literature research has been conducted. A total of 6 groups of bat characteristics have been chosen as relevant for the risk estimation: body dimensions, flight height, flight style and speed, foraging space and distance, response to light, and acoustical characteristics of bat calls. Their values have been presented in this paper for the 7 bat species that are represented in the wind park near Hamburg, Germany. Analyzing the values of the known bat characteristics, conclusions about the species with high collision risk possibility have been drawn. However, these conclusions have not always been supported by the statistics of carcass findings at wind parks across Germany, which raises questions, for instance about the degree of influence of certain characteristics above others, and indicates a need for further research.*

**Keywords:** *bat casualties; bat characteristics; wind turbines.*

---



## 1. Introduction

According to the German Federal Law of Nature Protection (Bundesnaturschutzgesetz), bats belong to the category of endangered animals and are particularly protected – it is forbidden to catch, injure or kill them. However, Hochradel et al. (2015) have proven that bats are attracted by wind turbines, and Brinkmann et al. (2011) have estimated that on average 9.5 bats are killed per wind turbine in the period from July to September in Germany.

With the idea of reducing CO<sub>2</sub> emissions and backing out of nuclear energy, Germany is actively increasing the share of renewable energy in its total generation mix. A total of 29248 onshore wind turbines with a cumulative capacity of 53.2 GW were operating in Germany by 30.06.2019 (Deutsche WindGuard GmbH 2019). Thus, the increasing number of wind turbines raises a concern for the bat population.

## 2. Bats and Wind Turbines

To estimate the risk from wind turbines on different bat species, a systematic literature research has been conducted and several bat characteristics have been selected. In this section, bat species represented in the study area, relevance of the selected bat characteristics and their values, as well as the wind turbine parameters of the study area are discussed.

### 2.1. Bat Species Represented in Hamburg

There are about 1400 bat species worldwide, of which 25 are represented in Germany (Nature Conservation Directive of the European Union). With the help of acoustical detectors, 7 species were identified in the area of an onshore wind park near Hamburg, Germany, during risk assessment studies in the planning phase (Reimers 2015): Serotine bat (*Eptesicus serotinus*), Daubenton's bat (*Myotis daubentonii*), Common noctule (*Nyctalus noctula*), Nathusius's pipistrelle (*Pipistrellus nathusii*), Common pipistrelle (*Pipistrellus pipistrellus*), Soprano pipistrelle (*Pipistrellus pygmaeus*), Brown long-eared bat (*Plecotus auritus*).

### 2.2. Relevant Bat Characteristics in Respect of Wind Turbine Casualties

To facilitate data gathering and comparison of different species, 6 groups of bat characteristics have been chosen: body dimensions (body mass, body length, wingspan), flight height (typical height and prediction rate of the bat to fly at heights), flight style and speed, foraging space and distance, response to light, and acoustical characteristics of bat calls (frequency range and intensity).

Bat body dimensions can give a general idea about the size of the carcasses in the event of bat casualties and their distribution possibilities. Comparing a rotor area altitude of a wind turbine with a typical flight height of a bat species, can identify potential conflict and high-risk zones. In the context of “shutdown-on-demand”, typical flight speed of bat species can

be used to approximate the minimal required distance to detect a bat from the operating wind turbine. Additionally, comparing a typical flight speed of a bat species with a linear speed of a blade at a certain point, one can comprehend the probability for a bat flying in the vicinity of a moving blade to evade it. Preferred foraging habitat by a bat species can to a certain degree predict its presence or absence in a wind park. Maximal foraging distance from a roost could help to estimate the probability of bat species activity near wind turbines, given that the roost locations are known. Bats vision and response to different wavelengths of light are also considered here as relevant, because obstruction lighting of wind turbines can attract or repel some bat species to the turbines.

Frequency range and volume of bat calls are characteristics that limit the acoustic detection distance of bats. Depending on these factors and the settings of the acoustical detector installed in the nacelle of a wind turbine, the detection range can vary greatly, e.g. from 70 m to 10 m (Simon et al. 2015) and less. Often, shut-down algorithms of wind turbines are based on the measured acoustic activity at the nacelle.

Bats are known to be active under certain weather conditions. However, the meteorological parameters are out of the scope of this paper, because they influence bats presence at wind turbines only temporarily. Migration of bat species is not considered for the same reason.

### 2.3. Known Bat Characteristics in Respect of Wind Turbine Casualties

The species that are represented in the wind park near Hamburg, typically have a head to body length of 35 -80 mm, a wingspan of 190 - 400 mm and a weight of 3 - 30 g (Dietz and Kiefer 2014; Bat Conservation Trust 2008).

According to Dietz and Kiefer (2014), *E. serotinus* bat species typically fly at 10 – 15 m altitudes; for *M. daubentonii* bat species that is 1 – 5 m, and for *P. nathusii* is 3 – 10 m. Seibert et al. (2013) recorded *P. pipistrellus* species at 0.5 – 4.5 m altitudes. Herrchen & Schmitt (2018) name similar values for the flight altitude of the above-mentioned species, and specify the typical flight height of 15 m and more for *N. noctula*, 3 – 6 m for *P. pygmaeus*, and 3 – 15 m for *P. auritus*.

Based on recorded data, Roemer et al. (2017) have predicted the rate of the time bat species spent at higher altitudes, and for the bat species represented in the wind park, the maximum value of 42.7 % is for *N. noctula* and minimum of 0.3 % is for small Myotis group, to which *M. daubentonii* belongs.

Dietz and Kiefer (2014) describe flight styles of *N. noctula* and *P. nathusii* as fast and linear, *P. pygmaeus* as utterly agile, *E. serotinus* as slow. As for *M. daubentonii*, *P. pipistrellus* and *P. auritus*, their flight styles are agile and fast, agile and twisty, agile and slow respectively. Average speed of travel is 5 m/s for *M. daubentonii* (Middleton 2006), more than 14 m/s for *N. noctula* (Dietz and Kiefer 2014) and 4 – 6 m/s for *P. pipistrellus* (Seibert et al. 2013).

Following the classifications of Denzinger and Schnitzler (2013) and of Roemer et al. (2017), *N. noctula* use open foraging spaces, while *P. nathusii*, *P. pipistrellus* and *P. pygmaeus* use edge foraging spaces, and *P. auritus* – narrow foraging spaces; *E. serotinus* and *M. daubentonii* species can use a combination of foraging spaces, open and edge, and edge and narrow respectively. As for the foraging distance, the two extreme examples are *N. noctula* and *P. auritus*. While one species can fly up to 25 km from the roost, the other typically stay within 0.5 – 2 km from the roost (Dietz and Kiefer 2014).

Similar to other characteristics, response to different wavelengths of light is species specific. As red and white lights are used in Germany for wind turbines illumination, only the behavior towards them is considered in this paper. Spoelstra et al. (2017) found no influence of red light on *Plecotus* and *Myotis* species activity and a reduction of it in white light; for *Nyctalus* and *Eptesicus* species, no effect of red or white light on bat activity was observed; *Pipistrellus* species were observed to be more active in white light and with no change in activity in red light. However migratory bats study by Voigt et al. (2018) revealed that *P. pygmaeus* and with a less extend *P. nathusii* species increased their activity in red light.

For the bat species represented in the wind park, frequency range of calls varied within 17 – 85 kHz (Dietz and Kiefer 2014). The calls intensity measured at 1 m distance for open space aerial foragers, to which belongs *N. noctula*, is 104 – 111 dB SPL; calls intensity for edge space aerial foragers, to which one could allocate *P. nathusii*, *P. pipistrellus* and *P. pygmaeus*, is 101 – 107 dB SPL; for *M. daubentonii* typical call intensity is 120 dB SPL (Denzinger and Schnitzler 2013). *P. auritus* is often described in literature as a quiet or whispering bat, but no explicit values for the call intensities are given.

A summary of the above-mentioned characteristics for bats represented in the wind park near Hamburg is given in the Table 1.

#### **2.4. Wind turbines characteristics**

To put things into perspective, the average configuration of new turbines which are being installed in Germany are 3.3 MW nominal power, 133 m hub height and 122 m rotor diameter (Deutsche WindGuard GmbH 2019).

The wind park near Hamburg consists of 5 wind turbines with the nominal power of 2.4 MW and 3.0 MW, hub height of 120 m, rotor diameter of 117 m, operational rotational speed in the range of about 7.5 – 14.1 RPM. The linear speed of the blade tip can vary from 46 to 86 m/s, and the lowest point of the blade tip is 61.5 m above ground. The wind park area is covered dominantly with arable land and grassland with a few ditches, so that wind turbines are located in an open space.

**Table 1. Characteristics of bat species represented in the wind park near Hamburg**

<b>Characteristics</b>	<b>Serotine bat (<i>Eptesicus serotinus</i>)</b>	<b>Daubenton's bat (<i>Myotis daubentonii</i>)</b>	<b>Common noctule (<i>Nyctalus noctula</i>)</b>	<b>Nathusius's pipistrelle (<i>Pipistrellus nathusii</i>)</b>	<b>Common pipistrelle (<i>Pipistrellus pipistrellus</i>)</b>	<b>Soprano pipistrelle (<i>Pipistrellus pygmaeus</i>)</b>	<b>Brown long-eared bat (<i>Plecotus auritus</i>)</b>
Body mass	18–25g	6–10g	21–30g	6–10g	3–7g	4–7g	6–9g
Body length	58–80mm	45–55mm	37–48mm	46–55mm	35–45mm	35–45mm	37–52mm
Wingspan	320–380mm	240–275mm	320–400mm	228–250mm	200–235mm	190–230mm	230–285mm
Flight height	5-15m	1-6m	>15m	3-20m	0.5–6m	3–6m	3–15m
Predicted rate	12.7%	0.3%	42.7%	26.7%	11.3%	4.5%	0.5%
Flight style	Slow	fast&agile	fast&linear	fast&linear	agile&twisty	utterly agile	slow&agile
Speed of travel	–	5m/s	>14m/s	–	4–6m/s	–	–
Foraging space	open/edge	edge/narrow	open	edge	edge	edge	narrow
Foraging distance	4.5km	2.3-3.7km	<25km	<6.5km	1.5km	1.7km	0.5–2km
Activity at:-red -white light	retained retained	retained reduced	retained retained	retained/increased increased	retained increased	retained/increased increased	retained reduced
Frequency range	22–26kHz	26–85kHz	17–21kHz	35–40kHz	41–46kHz	50–57kHz	24–55kHz
Intensity at 1m	–	100dB SPL	104–111dB SPL	101–107dB SPL	101–107dB SPL	101–107dB SPL	–

### 3. Discussion

During the conducted literature research, it has been revealed, that the information about body dimensions, typical flight height, flight style, preferred foraging spaces and typical foraging distances from roosts for different bat species is very accessible. Speed of travel or flight speed of different bat species are not very accessible, which is probably due to the agile flight styles of the most bats species in wind park near Hamburg. Bats vision and their response to light is a relatively new research topic, and few studies are published yet, so the information might be refined in the future. Although information about frequency range of calls for different bat species is widely accessible, information about intensity of these calls is not very conclusive, which is probably due to the complexity of the needed setup for a study.

When comparing the data gathered in Table 1 with the description of the wind park, the *N. noctula* species stands out. Due to typically high flight altitudes and preference of an open space for foraging, the habitat of this species highly overlaps with the rotor area of the wind turbines. This indicates a high collision risk possibility, and Dürr (2019) demonstrates that carcasses of *N. noctula* are the most frequently found and registered in Germany with 32.24 % share. The other two species to stand out are *P. nathusii* and *E. serotinus*. Flying typically lower than *N. noctula* and preferring more edge space for foraging, the carcasses finding share is 28.76 % for *P. nathusii* and 1.71 % for *E. serotinus* (Dürr 2019). *P. pipistrellus* and *P. pygmaeus* seem also to have similar characteristics, but their finding share is 19.05 % and 3.65 % respectively (Dürr 2019). The species with the least collision risk possibility for the wind park near Hamburg appear to be *M. daubentonii* and *P. auritus*, which is aligned with findings of Dürr (2019) who documented 0,19 % from all of the found carcasses for each of these species.

The controversy over the finding of Dürr (2019) and the data from the literature research for *P. nathusii*, *E. serotinus*, *P. pipistrellus* and *P. pygmaeus* raise questions about the degree of influence of certain characteristics above others. Do certain wavelengths of light attract some bat species to substantially higher altitudes than they typically use? How will activating obstruction lighting of wind turbines only on need change the found carcass distribution? Are species with frequently found carcasses more represented in the area and what does their frequent killing mean for their population? How to optimize shut down algorithms of wind turbines in order to protect bats? These and other questions are still open and further research is needed.

## References

- Bat Conservation Trust (2008): Noctule bat. *Nyctalus noctula*. London. Available online at [www.bats.org.uk](http://www.bats.org.uk), checked on 3/27/2019.
- Brinkmann, Robert; Behr, Oliver; Niermann, Ivo; Reich, Michael (Eds.) (2011): Entwicklung von Methoden zur Untersuchung und Reduktion des Kollisionsrisikos von Fledermäusen an Onshore-Windenergieanlagen. Göttingen: Cuvillier Verlag (Umwelt und Raum, Bd. 4).
- Denzinger, Annette; Schnitzler, Hans-Ulrich (2013): Bat guilds, a concept to classify the highly diverse foraging and echolocation behaviors of microchiropteran bats. In *Frontiers in Physiology* 4. DOI: 10.3389/fphys.2013.00164.
- Deutsche WindGuard GmbH (2019): Status des Windenergieausbaus an Land in Deutschland. Erstes Halbjahr 2019. Available online at <https://www.windguard.de/statistik-1-halbjahr-2019.html>, checked on 8/14/2019.
- Dietz, Christian; Kiefer, Andreas (2014): Die Fledermäuse Europas. Kennen, bestimmen, schützen. Stuttgart: Kosmos.
- Dürr, Tobias (2019): Fledermausverluste an Windenergieanlagen in Deutschland. Daten aus der zentralen Fundkartei der Staatlichen Vogelschutzwarte. Landesamt für Umwelt Brandenburg. Available online at <http://www.lfu.brandenburg.de/cms/detail.php/bb1.c.312579.de>, checked on 8/30/2019.
- Bundesnaturschutzgesetz, 9/15/2017: Gesetz über Naturschutz und Landschaftspflege.
- Herrchen & Schmitt (2018): L3193 Ausbau - Artenschutzrechtlicher Fachbeitrag. Prüfbögen der anweisen Konfliktanalyse.
- Hochradel, Klaus; Adomeit, Uwe; Heinze, Nic; Nagy, Martina; Stiller, Florian; Behr, Oliver (2015): Wärmeoptische 3D-Erfassung von Fledermäusen im Rotorbereich von Windenergieanlagen. In Oliver Behr, Robert Brinkmann, Franzi Korner-Nievergelt, Martina Nagy, Ivo Niermann, Michael Reich, Ralph Simon (Eds.): Reduktion des Kollisionsrisikos von Fledermäusen an Onshore-Windenergieanlagen (RENEBAT II). Umwelt und Raum Bd. 7. Hannover: Schriftenreihe Institut für Umweltplanung, Hannover, pp. 81–100.
- Middleton, Neil E. (2006): The speed of travel of *Myotis daubentonii* along canal corridors in central Scotland. In *BaTML Publications* 3, pp. 19–22. Available online at [www.batml.org.uk](http://www.batml.org.uk).

Nature Conservation Directive of the European Union: Richtlinie 92/43/EWG des Rates vom 21. Mai 1992 zur Erhaltung der natürlichen Lebensräume sowie der wildlebenden Tiere und Pflanzen. FFH-Richtlinie.

Reimers, Holger (2015): Windpark Curslack Fachbeitrag Fledermäuse. UIN - Umweltkartierung- Informationsverarbeitung Umweltbewertung.

Roemer, C.; Disca, T.; Coulon, A.; Bas, Y. (2017): Bat flight height monitored from wind masts predicts mortality risk at wind farms. In *Biological Conservation* 215, pp. 116–122. DOI: 10.1016/j.biocon.2017.09.002.

Seibert, Anna-Maria; Koblitz, Jens; Denzinger, Annette; Schnitzler, Hans-Ulrich (2013): Scanning Behavior in Echolocating Common Pipistrelle Bats (*Pipistrellus pipistrellus*). In *PLOS ONE* 8 (4). DOI: 10.1371/journal.pone.0060752.

Simon, Ralph; Hochradel, Klaus; Mages, Jürgen; Nagy, Martina; Naucke, Andreas; Niermann, Ivo et al. (2015): Methoden akustischer Erfassung der Fledermausaktivität an Windenergieanlagen. In Oliver Behr, Robert Brinkmann, Franzi Korner-Nievergelt, Martina Nagy, Ivo Niermann, Michael Reich, Ralph Simon (Eds.): Reduktion des Kollisionsrisikos von Fledermäusen an Onshore-Windenergieanlagen (RENEBAT II). Umwelt und Raum Bd. 7. Hannover: Schriftenreihe Institut für Umweltplanung, Hannover, pp. 39–80.

Spoelstra, Kamiel; van Grunsven, Roy; Ramakers, Jip; Ferguson, Kim; Raap, Thomas; Donners, Maurice et al. (2017): Response of bats to light with different spectra: light-shy and agile bat presence is affected by white and green, but not red light. In *Proceedings of The Royal Society* 284. DOI: 10.1098/rspb.2017.0075.

Voigt, Christian; Rehnig, Katharina; Lindecke, Oliver; Petersons, Gunars (2018): Migratory bats are attracted by red light but not by warm-white light: Implications for the protection of nocturnal migrants. In *Ecology and evolution*, pp. 9353–9361. DOI: 10.1002/ece3.4400.

5th CARPE Conference  
HORIZON EUROPE AND BEYOND



UNIVERSITAT  
POLITÈCNICA  
DE VALÈNCIA

VALENCIA (Spain)

23-25<sup>TH</sup> OCTOBER 2019

INNOVATION



UNIVERSITY of  
DEBRECEN





## Use of wireless communication networks in digitalization of factory environments

Tuomo Rautava<sup>1</sup>, Jarkko Paavola<sup>1</sup>, Juhani Hallio<sup>1</sup>, Juha Kalliovaara<sup>1</sup>, and Tero Jokela<sup>1</sup>

<sup>1</sup>Turku University of Applied Sciences, Turku, Finland

---

### **Abstract**

*Wireless communications are rapidly taking an important role in factory environment. The current Wi-Fi technologies struggle to meet the requirements of industrial factories, for example with regard to latency and security. The emerging 5G communication networks are the first networks expected to meet such requirements. Private networks can be owned by the factories themselves. Private networks can utilize 5G technologies to tailor the networks to meet the exact demands within the factory environment and guarantee that the factories can use the whole capacity for their own use. This concurrently increases the data security as the data does not need to be delivered over public networks. The paper describes the latest developments in 5G with regard to private networks and Industry 4.0, which is the name given to the digitalization, automatization and data exchange trend currently ongoing in factory environments. In this paper we describe a private cellular network we have installed inside a factory building. This network has been trialed with wireless pyrometer measurement data transmission and environmental surveillance of a measurement laboratory. The paper analyses the suitability of private networks for these use cases and discusses in general which applications would benefit the most from private wireless networks.*

**Keywords:** *Private network, factories, 5G, digitalization.*

---

## **1. Introduction**

Wireless communications enable remote control and remote surveillance of factory environments. The currently widely used Wi-Fi technologies (eg. 802.11ac) struggle to meet the requirements of the manufacturing industry. For example, in remote control, low latency and very high reliability are required. These are not fulfilled with the shared ISM frequency bands used by Wi-Fi (2.4 GHz and 5 GHz). These frequencies may have other transmissions, which can lead to fluctuations in the latency and the bit rate of the Wi-Fi data transmission.

The emerging 5G communication networks are the first networks expected to meet such requirements. 5G technology and private networks can guarantee the desired quality of service. 5G can also create network slices optimized for different applications within the same physical network.

Turku University of Applied Sciences has examined transfer of welding data using the 5G networks and built a wireless data transmission system for temperature data of a welding robot. A 5G network can be used to transfer the temperature monitoring data during welding to a product life cycle management (PLM) system.

This research has been conducted in DigRob project, which is funded by BusinessFinland and aims to develop robotic welding to be profitable also in single-piece production.

## **2. 5G in factory environment**

The fifth-generation cellular network (5G) has been designed in many ways to be more versatile than its predecessors (Andrews et al 2014). With 5G, mobile network throughput can be increased to tens of gigabits per second. In addition to high throughput, 5G also delivers very small latency (< 1 ms), which in turn is an enabler for applications that require real-time feedback. In addition to these enhancements, 5G enables the use network slicing. Network slicing allows network operators to create virtual network slices to serve, for example, various industries, self-driving cars, and basic users using the same physical network infrastructure. Network slices can be used to provide different user groups with customized service quality. For example, for connected cars, low latency is more important than a extremely high bit rate, while for a basic user a high bit rate may be more important for video viewing. The first 5G networks are currently being deployed and the first 5G terminals are entering the market.

Company-owned 4G or 5G private networks allow the company to build a network to meet its own specific needs (Matinmikko-Blue & Latva-Aho, 2017). Thus, the network can be made very secure, necessary coverage of the network can be built, and the entire bandwidth is in the company's own use. Network computing capacity can be enhanced and end-to-end latency decreased by using local servers instead of cloud servers on the Internet.

Private networks are built for example to factory and warehouse areas where commercial networks may be inadequate to meet the company's needs. Global Markets Insights forecasts that the global market for private mobile networks will grow to \$ 11 billion by 2024 (Global Markets Insights, 2018). Private networks are not a replacement for commercial cellular networks, but rather complementary networks for use cases where the speed or security of commercial networks is insufficient. In Finland, private networks have been built for example to Helsinki-Vantaa Airport (Nokia, 2017) and for the crane manufacturer Konecranes Hyvinkää campus (Konecranes, 2018).

The new era of automation and data transfer in the manufacturing industry is called Industry 4.0. It focuses for example on the integration and mutual exchange of information between different devices and systems, the Internet of Things (IoT) and sensing, the remote control of machines, the use of augmented reality in factory environments and other completely new services enabled by technical development. Wireless networks and especially private networks play a key role in the digitalization of industrial processes, where Finland strives to gain a significant competitive advantage by being at the forefront of development.

### **3. Measurements in TUAS #factory**

An assessment of spectrum usability in a factory environment was carried out at the TUAS #factory at Machine Technology Center Turku by measuring the utilization rate of radio frequencies with a recording spectral analyzer. Using the spectrum analyzer, the occupancy value (0-100%) was calculated for all the measured frequencies at 10 kHz resolution. First, the 700 MHz and 3.5 GHz frequency bands were measured as they are the first bands to be used for 5G. These frequencies have already been nationally auctioned to operators in Finland, but their use for example in the factory environments is possible through independent agreements with the operators. Figure 1 shows the spectrum analyzer hardware. The measurements concluded that no interference or other transmissions that would prevent the use of frequencies in either frequency band inside the TUAS #factory were found.



Figure 1. The CRFS RFeye spectrum measurement equipment.

After assessing spectrum availability, a private network operating on 3.5 GHz frequency was installed inside the TUAS #factory environment and network coverage measurements were conducted. Sufficient coverage and capacity for this environment were achieved with two low power base stations.

### 3.1. Pyrometer system

The cooling time of the weld from 800°C to 500°C is very important in determining the welding parameters applied during welding of fine-grain structural steels. This time is described by Delta T8/5 parameter. This parameter refers to the time in seconds when the temperature of the steel joint is in the range of 800°C to 500°C after welding. Stronger steels and steels with better fracture strength need to be welded more precisely in terms of the cooling time so that the properties of the base material are sufficient also after the welding. Steel manufacturers generally give their recommendation for the Delta T8/5 parameter. The cooling time can be determined by the geometry of the body, the welding parameters, or it can be measured for example by a pyrometer.



Figure 2. Wireless pyrometer setup.

In this paper, a wireless communication system was built into a commercially available pyrometer. The system is based on a cellular network technology. The built portable installation with its battery installed inside a case is shown in Figure 2. The pyrometer is installed into the metallic arm on the right side of the case. This allows measuring the cooling time of the weld at critical locations with easily portable equipment. The measured temperature data is stored locally in the memory associated with the sensor, from which it is wirelessly transferred into the cloud. The 3.5 GHz private network installed into the factory was successfully used for data transfer. The T8/5 value is calculated from the data at the visualization and reporting stage and stored with a time stamp. The goal is to store the T8/5 value of each piece later into the PLM system. Figure 3 shows the arm and the pyrometer system installed to monitor a welding robot.



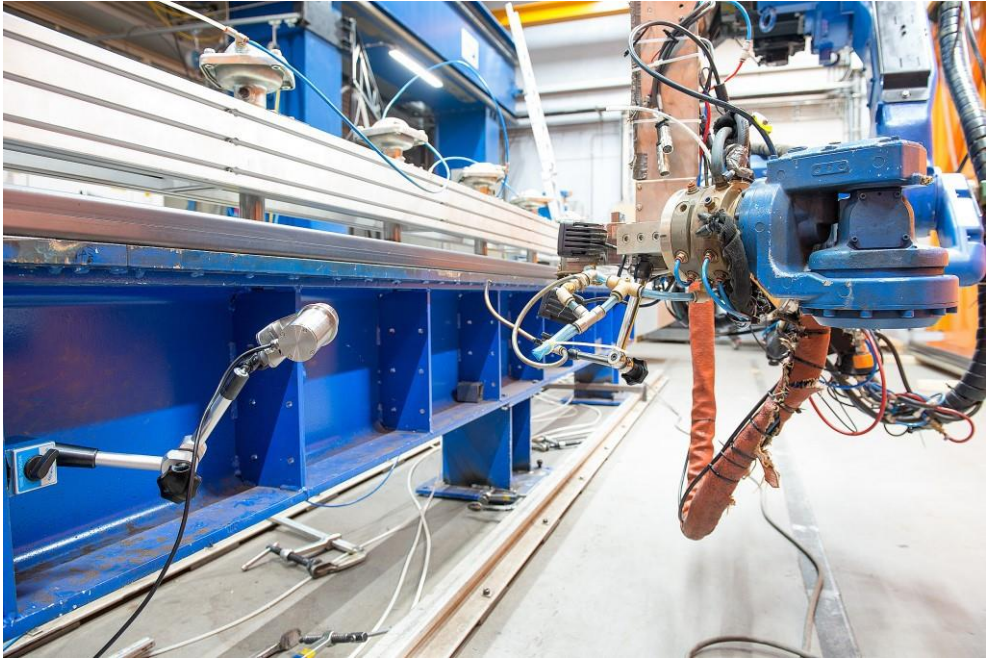

Figure 3. Pyrometer installed to the welding station.

### 3.2. Measurement room sensing system

The conditions must remain standardized at the measurement and calibration laboratory, where the coordinate measuring machine is located. For this purpose, a wireless sensor was installed to measure the conditions inside the measurement and calibration laboratory at the Machine Technology Center. The sensor was used to measure the room temperature, humidity, lightness, and motion in the room. The sensor works wirelessly and has a battery which lasts for more than a year.

The data generated by the sensor can be visualized for remote monitoring in the same cloud-based service as with the pyrometer. If the values measured by the sensor differ from the set limit values, an alarm is given. The installed wireless system does not replace the standardized monitoring system, but allows remote monitoring of the measurement and calibration laboratory.

## 4. Conclusions

In this paper, we have taken a step towards the future factory by providing added value through a wireless private cellular network. The wireless communication system developed

for the pyrometer makes the equipment portable, making it easy to move the equipment to a desired location, for example when welding large pieces. In turn, remote sensing of the measurement and calibration laboratory is facilitated by wireless sensors. In the future, as mobile robots, collaborative robots and remote control become more widespread, the importance of wireless communications will largely increase in factory environments.

## References

- Andrews, J. G. et al (2014), What Will 5G Be?, in *IEEE Journal on Selected Areas in Communications*, vol.32, no.6, pp.1065-1082, June 2014, doi: 10.1109/JSAC.2014.2328098
- Global Markets Insights (2018), *Industry Analysis Report: Private LTE Market Size By Component, Device, Service, Application and Regional Outlook, Growth Potential, Competitive Market Share & Forecast, 2018 – 2024*, November 2018.
- Konecranes (2018), *Konecranes, Nokia and Ukkoverkot to cooperate - smart cranes depart on the 5G journey*, January 2018. Available online: <https://www.konecranes.com/press/releases/2018/konecranes-nokia-and-ukkoverkot-to-cooperate-smart-cranes-depart-on-the-5g-journey>, Accessed June 24<sup>th</sup> 2019.
- Matinmikko-Blue, M. and Latva-Aho, M. (2017), Micro operators accelerating 5G deployment, *2017 IEEE International Conference on Industrial and Information Systems (ICIIS)*, Peradeniya, pp.1-5. doi: 10.1109/ICIINFS.2017.8300396
- Nokia (2017), *Nokia to modernize private nationwide LTE network for Finland's Ukkoverkot, supporting industrial and public safety services*, available online: <https://www.nokia.com/about-us/news/releases/2017/09/19/nokia-to-modernize-private-nationwide-lte-network-for-finlands-ukkoverkot-supporting-industrial-and-public-safety-services/>, September 2017. Accessed June 24<sup>th</sup> 2019.

## Implementing the Rights of the Child

Cees Hoefnagels<sup>1</sup>, Anna van Spanje<sup>1</sup>, Saskia Wijsbroek<sup>1</sup>

<sup>1</sup>Research Centre Social Innovation, HU University of Applied Sciences Utrecht, The Netherlands.

---

### **Abstract**

*Although the 1989 United Nations Convention on the Rights of the Child (UN CRC) has been ratified by almost all countries, and children's rights have been well documented, the rights of many children are neglected and violated on a daily basis. We propose to initiate several pilot projects and corresponding studies, followed by dissemination and implementation activities, in order to raise awareness of children's rights among youth professionals and children, and implement children's rights in professional practice.*

*We have some options and ideas to perform these research activities in the Netherlands, but we are looking for international partners so we can a) learn from previous experiences and b) accomplish that more people and organizations benefit from the projects and findings. At the 2019 CARPE conference, our aim is to find universities of applied sciences that have expertise on children's rights, and that are willing to collaborate with us on further developing and carrying out the proposed research.*

**Keywords:** *children's rights; child welfare; youth care.*

---



## **1. Background**

Although almost all countries have ratified the United Nations Convention on the Rights of the Child (UN CRC) (United Nations Committee on the Rights of the Children, 1989), children's rights are ignored every day, including in Europe. Daily practice in health and youth care reveals that ignoring and violating children's rights appears to be rather the rule than the exception. This includes youth professionals who are willing or assume to act in the best interests of the child.

Across many social domains (in particular in health), a much heard complaint is that children do not feel taken seriously. Many decisions that will affect the child's life, for instance regarding family interventions in child abusive families, or being removed from their home, are indeed made by adults unilaterally without taking the child's opinion into consideration too frequently (Lansdown, 2011; also see UN CRC, art. 12; United Nations Committee on the Rights of the Children, 1989), and refrain the child from the right to oppose against the intervention.

It appears that on all levels in society people – children and adults, professionals and policymakers – are not (fully) aware of the UN CRC (National Youth Council, 2019; The Dutch NGO Coalition for Children's Rights, 2019). As most children and adults are unaware of children's rights, these rights are regularly ignored by their parents, youth professionals and other children in addition to society as a whole without knowing or acknowledging it. Therefore, the objective of this project is to change the current practice, to reverse the rule and the exception, and monitor the changes.

The UN Committee on the Rights of the Children (2013) describes what the convention and articles imply. For example, the General comment No. 14 describes what the right of the child to have his or her best interests taken as a primary consideration means. Article 3, paragraph 1, states: "In all actions concerning children, whether undertaken by public or private social welfare institutions, courts of law, administrative authorities or legislative bodies, the best interests of the child shall be a primary consideration." (United Nations Committee on the Rights of the Children, 2013, p.3).

Thus, the best interests of the child serve as a fundamental right, a principle and a rule of procedure. Later on, the importance of this right is being underlined: "Article 3, paragraph 1, of the Convention on the Rights of the Child gives the child the right to have his or her best interests assessed and taken into account as a primary consideration in all actions or decisions that concern him or her, both in the public and private sphere. Moreover, it expresses one of the fundamental values of the Convention. The Committee on the Rights of the Child (the Committee) has identified article 3, paragraph 1, as one of the four general principles of the Convention for interpreting and implementing all the rights of the child, and applies it as a dynamic concept that requires an assessment appropriate to the specific context." (United

Nations Committee on the Rights of the Children, 2013, p.3). These and other quotes show that children's rights have been put into words very well. Corresponding actions, however, are lacking.

In sum, although children's rights have been internationally officially recognized for 30 years, these rights are being ignored and violated every day, everywhere. With the proposed project, we aim to bring children's rights to the attention of both youth professionals and children, and implement children's rights in daily practice.

## **2. Project proposal**

In order to reach the aforementioned goal, we have come up with several actions:

- 1) A series of pilot projects will be conducted in order to raise awareness and to implement children's rights in daily practice, among youth professionals and children.
- 2) These projects will be monitored through longitudinal multi-method (qualitative and quantitative) studies.
- 3) Networking conferences will be organized to a) design the pilot projects in the initial stage, and b) learn about the conditions in the final stages.
- 4) We will disseminate and implement the gained evidence.

### ***2.1. Possibilities in the Netherlands***

Focusing on recent initiatives in the Netherlands only, several options for pilot projects can be considered. One option for example, includes a process evaluation and an evaluation of the dissemination of two different Dutch approaches that both address the implementation of children's rights in primary education settings (schools) in the Netherlands and their results.

Another option is to assess to which extent youth professionals comply with / adhere to the recent developed standard procedure on reporting child abuse and neglect while acknowledging the rights of the child. The law that introduced the procedure was enacted in the Netherlands on January 1<sup>st</sup> of this year. To this end a guide was developed (Geurts, Hokwerda, Bouma, Winder & Hoefnagels, 2018) which should facilitate professionals to include the child's rights in their considerations and behavior, as a professional precondition when faced with a suspicion of child abuse and neglect.

In addition, there are plans to select some neighborhoods in the Netherlands in which researchers create conditions, install procedures and empower children and parents in order to make these neighborhoods child rights-proof over the next decade. We could contribute to and study these initiatives.

## **2.2. European collaboration through CARPE**

Even though there are several research possibilities in the Netherlands on the topic of children's rights, we would like to extend our plan to other countries. We believe that European collaboration will make our research more solid. Furthermore, the implementation of children's rights is important for children and youth professionals everywhere.

At the 2019 CARPE conference we will gather the existing, planned and potential projects across the participating universities of applied sciences. Based on the initiatives in these countries, the nature of the proposed pilot projects will be explored together. The proposed pilot projects will be discussed in order to select a set of complementary projects which serve the objectives most, including a maximum gain of evidence.

We are eager to hear about other initiatives on implementing children's rights, so we can learn from those experiences. Together with CARPE partners, we could either design new research projects or (adapt and) carry out projects that seem promising or have proven to be successful in other countries. Specific topics include but are not limited to homeless children, unaccompanied minors foreign nationals, and disappearance of children (see The Dutch NGO Coalition for Children's Rights, 2019, for more examples).

Besides collaboration with the universities of applied sciences that are joined in CARPE, we would also like to expand our network with other possible contributors, namely the organizations that CARPE universities are working with on the topic of children's rights. For example advocacy organizations (like Defence for Children, one of our current partners), health and youth care professionals, policy makers, and local governments could contribute to and benefit from the proposed project.

## **References**

- Geurts, E., Hokwerda, Y., Bouma, H., Winder, L. & Hoefnagels, C. (2018). *Handreiking 'Participatie van kinderen in de Meldcode huiselijk geweld en kindermishandeling'*. Den Haag: Ministerie van Volksgezondheid, Welzijn en Sport.
- Lansdown, G. (2011). *Every child's right to be heard. A resource guide on the UN committee on the rights of the child General comment No. 12*. London: The Save the Children Fund.
- National Youth Council (2019). *There to talk, dare to listen. Dutch youth on the children's rights treaty*. Utrecht: NJR.
- The Dutch NGO Coalition for Children's Rights (2019). *Children's rights in the Netherlands: Input to the list of issues of the UN Committee on the Rights of the Child*. Leiden: Kinderrechtencollectief.
- United Nations Committee on the Rights of the Children (1989). *Convention on the Rights of the Child*. Available at: <https://www.ohchr.org> [accessed 5 July 2019].
- United Nations Committee on the Rights of the Children (2013). *General comment No. 14 on the right of the child to have his or her best interests taken as a primary consideration*

(art. 3, para. 1). CRC/C/GC/14. Available at: <https://www.ohchr.org> [accessed 5 July 2019].

## How to scale the societal impact of work-integration social enterprises? Evidence from The Netherlands

Leendert de Bell<sup>1</sup>, Linda Drupsteen<sup>2</sup>

<sup>1</sup>Research Centre for Social Innovation, University of Applied Sciences Utrecht, The Netherlands, <sup>2</sup>Research Group New Employment Relations, Windesheim University of Applied Sciences, The Netherlands.

---

### **Abstract**

*The number of social enterprises in the Netherlands has increased rapidly. Social enterprises are looking for new, innovative and economically sustainable ways to tackle structural societal challenges that generally fall outside the direct focus and objectives of the public and private sector. Social enterprises are primarily mission-driven, where profit is not a goal in itself but a means of creating societal impact with regard to a specific social problem. Many social enterprises aim to increase their societal impact by growing their organization. However, despite their ambition, scaling up and expanding their impact remains challenging in practice. This research aimed to identify the main constraining factors in scaling up social enterprises and to develop effective methods to tackle these barriers in order to achieve more societal impact. The research was conducted among twenty social enterprises in the Netherlands, all of which aim to stimulate the labor market participation of people who are at a distance from the labor market, generally referred to as work-integration social enterprises. The results show that the majority of the participating social enterprises succeeded in achieving growth in the past two years with regard to specific indicators, but generally not in the way they had originally planned.*

**Keywords:** Social Enterprises; Work Integration; Scaling; Societal Impact.

---

## **1. Introduction**

Social enterprises are looking for new, innovative and economically sustainable ways to tackle structural societal challenges that generally fall outside the direct focus and objectives of the public and private sector (Witkamp et al., 2011). As such, social enterprises are primarily mission-driven, where profit is not a goal in itself but a means of creating societal impact with regard to a specific social problem (Martin & Osberg, 2007; Nicholls, 2006). The intended impact areas of social enterprises can range from internationally oriented initiatives such as poverty reduction, environmental sustainability, to initiatives to promote the sharing economy or labor market participation.

Over the past decade, the number of social enterprises in the Netherlands has increased rapidly (Bosma et al., 2016). The majority of Dutch social enterprises, around 60% (Social Enterprise NL, 2015), focus on improving the labor market participation of vulnerable target groups (e.g. people with low labor qualifications, young people disengaged from education, people with mental or physical disabilities, former prisoners, former addicts, people who have difficulties finding a job due to their advanced age, or refugees). The number of people formally registered within this target group in the Netherlands still exceeded 200.000 people in 2017 (UWV, 2017).

Social enterprises contributing to labor market participation are generally referred to as work-integration social enterprises (WISEs). The direct impact of WISEs include offering activation, structure and financial self-sufficiency to the individual. Indirect benefits to the individual may be increasing self-awareness and self-esteem. The broader benefits for society include cost savings on benefits and healthcare. Given the considerable societal challenge, many social enterprises aim to increase their societal impact by growing their organizations. However, previous studies show that scaling up and expanding the societal impact remains challenging in practice, and that many social enterprises fail to have societal impact beyond the local level (Lyon & Fernandez, 2012; Elkington et al., 2010).

The objective of this research was to identify the main constraining factors in scaling up work-integration social enterprises in the Netherlands and to develop effective methods to tackle these constraints in order to achieve more societal impact and improve the labor market participation of vulnerable target groups. The next section provides a brief explanation of the research design, followed by the most important research results. In the final section, the main conclusions are summarized.

## **2. Methodology**

This research took place from March 2017 to February 2019, and was conducted among twenty work-integration social enterprises in the Netherlands. The participating social enterprises varied in size and in economic sector in which they were active (e.g. IT, catering, facility services, production and assembly) but were primarily selected on the basis of their economically viable business model, with at least 75% of their revenue generated from the marketplace, and their ambition to increase their societal impact. The research design was divided into five interview rounds and an intervention phase. In each interview round, the researchers conducted in-depth interviews with representatives of all participating social enterprises, usually the founder/owner of the social enterprise. All interviews are structured with the help of a thematic script. All interviews were recorded, then written out and analyzed using qualitative analysis software.

The first two interview rounds formed the basis for the research, and were aimed at gaining insight into the way in which the economic and social value creation of the participating social enterprises is organized. In order to map the economic value creation of the participating social enterprises, a modified “Business Model Canvas” was used. This model, originally designed by Osterwalder and Pigneur (2010), provides insight into the important business aspects in a well-organized manner by means of nine building blocks (value proposition, customer segments, channels, customer relationships, key activities, key resources, key partners, cost structure and revenue streams). With regard to the value proposition and customer segments, an extra distinction is made in the “Social” Business Model Canvas, between the value for paying customers and the value for the target group. Furthermore, an extra category has been added that indicates what will be done with the possible profit (surplus). In the second interview round, the social value creation of the participating social enterprises was mapped using the “Theory of Change” (Clark, 2012). This is a planning model that first defines which long-term objective should be achieved, then which changes should take place, and finally which interventions could produce the desired outcomes.

Interview rounds three and four focused on, respectively, the internal and external barriers that the participating social enterprises encountered in scaling up their activities. The third interview round mapped the power and weaknesses of the internal organization of social enterprises in relation to scaling up. The so-called “SCALERS” model (Bloom, & Chatterji, 2009), which identifies seven organizational capacities that play an important role in successful upscaling of social enterprises was used: Staffing, Communicating, Alliance-Building, Lobbying, Earnings-Generation, Replicating, and Stimulating Market Forces (SCALERS in acronym). The fourth interview round aimed at mapping the external environment of the participating social enterprises. To this end, the “Entrepreneurial

Ecosystem” approach has been used (Stam, 2015). This specific model distinguishes systemic circumstances that are subject to change such as networks, leadership, finance, talent, knowledge, support services, and the more static framework conditions such as institutions, infrastructure, culture, and market. These external factors can both stimulate and hinder the scaling up of social enterprises.

An intervention phase followed, which aimed to develop methods to tackle the observed obstacles to scaling up. These interventions consisted of a number of thematic master classes and an individual consultation with business consultants to address the internal constraints to growth. With regard to external barriers, a number of important stakeholders were consulted, with whom two focus group meetings were organized to increase mutual understanding and arrive at more workable solutions. A final round of interviews was held with representatives of all participating social enterprises, in which they reflected on the development of their social enterprises during the course of the research project (2017-2019), in order to be able to answer the question to what extent they succeeded in increasing their societal impact.

### **3. Main findings**

#### ***3.1. Constraining factors to growth***

After the first four rounds of interviews, five main categories of obstacles to growth were identified: three internal constraints (Human Resource Management, Processes and Systems, Marketing and Branding) and two external constraints (Intake of the target group and Access to finance).

A first internal obstacle for scaling up that was mentioned by the participating WISEs involved good staffing, specifically people who do not belong to the target group, for example coaches or people in staff positions. Guiding and coaching of the target group is generally intensive and therefore expensive, while the financial compensation that is available for coaching the target group is often not sufficient. Since the employment conditions for certain key positions at social enterprises are often less competitive than for comparable positions at regular enterprises, many WISEs experience difficulties in finding experienced and well-qualified people with the required enthusiasm. As a result, the founder/owner often has to do a lot of extra work him or herself.

This also contributes significantly to a second internal obstacle to growth: the absence of a clear structure in processes and systems. Some of the participating social enterprises work mainly on an ad hoc basis, which makes it difficult to replicate the business model. In order to scale up successfully and be able to handle more and larger orders efficiently,



professionalization and redesign of the organization is often inevitable. This may include automation, outsourcing of activities and entering into new partnerships.

A third internal obstacle to growth is related to communicating the multiple value proposition. With regard to marketing and branding, many companies have doubts if and how they should bring their social message across. Many fear that it may affect their carefully constructed reputation based on quality and service. As a consequence, some WISEs choose not to communicate their social message openly, while, with better marketing and branding of their multiple value, many customers can actually be won here.

One of the most prominent external constraints to growth of the participating WISEs is the intake of the target group. This intake is most commonly organized by local municipalities, which are officially responsible for guiding the target group to the labor market. In practice, however, the matching process of the target group with WISEs is often experienced as extremely difficult. Municipalities do not always have sufficient insight into suitable candidates, which hampers a smooth, low-threshold intake of the target group. As a consequence, many WISEs feel forced to look for candidates through other channels. There are also major differences across the Netherlands in the way in which different municipalities implement the Participation Act (2015). which can be determined by the number of inhabitants of a municipality, the political orientation of the local administration and the composition of the regional labor market. As a result, replicating a proven business model elsewhere is nearly impossible.

An second external constraint for growth, according to the participating WISEs is access to finance. Although most participating social enterprises can count on a stable customer base and a solid revenue stream, the margins are often small. The necessary investments for scaling up consequently almost always require external financing. Although there is a great diversity of financing options, many social entrepreneurs do not know exactly where and when to turn to for financing. Misunderstandings between social enterprises and financial institutions regarding the social and commercial objectives are common. Financial assessment criteria are considered first, while in addition, social enterprises have to meet hard performance requirements with regard to the scalability of the societal impact. The societal impact is generally not that easy to measure, even for financing instruments specifically created for social enterprises, such as the Social Impact Bonds. Consequently, the hybrid objective of these social enterprises often seems to be more of a burden rather than an advantage.

### ***3.2. Scaling up societal impact***

From the final round of interviews it becomes clear that the vast majority of participating social enterprises have succeeded in achieving growth with respect to one or more indicators over the research span of two years (2017-2019), although the degree of growth

differs widely between the participating WISEs due to differences in starting positions, economic sectors, and approaches towards the target group. Four indicators of growth that were examined in relation to the starting point include: growth in revenue, growth in the number of customers, growth in the number of employees from the target group and growth in the number of locations (Table 1).

**Table 1. Growth indicators of participating WISEs (2017-2019)**

WISEs	Revenue	Customers	Employees	Locations
1	0	0	0	0
2	+	+	+	+
3	+	+	+	0
4	+	+	+	0
5	+	+	-	+
6	+	+	-	0
7	+	0	+	0
8	+	+	+	+
9	+	0	+	0
10	+	+	-	0
11	0	0	0	0
12	+	+	+	0
13	0	0	0	0
14	0	0	0	0
15	+	0	0	-
16	+	+	+	0
17	+	+	+	0
18	+	0	+	+
19	+	+	+	0
20	0	+	+	0

(+) increase, (0) unchanged, (-) decrease

As shown in table 1, most participating WISEs experienced growth in revenue. This is an important indicator because it demonstrates that social enterprises are successful in realizing economic value from the market. The majority of the participating WISEs also experienced growth in relation to the second indicator: the number of customers. This is an important condition for achieving the intended social or societal impact, because a larger number of customers generally enables companies to help more people (structurally) at work. With respect to the third indicator, the number of employees from the target group, the majority of the participating WISEs have also effectively succeeded in achieving growth, which directly contributes to their intended growth in societal impact. It is striking that, contrary to the original objectives of many of the participating WISEs, only a small minority have achieved growth by opening up new locations.

With regard to the indicators that remained unchanged or decreased, most WISEs expect this to be temporary, and that investments in professionalizing the organization for example will pay off in growth in impact in the (near) future. It does appear, however, to be particularly difficult for WISEs in the Dutch context to replicate the business model in another location, primarily as a result of the major differences between Dutch municipalities with regard to the way in which the intake of the target group is arranged. Consequently, many social enterprises have instead opted to expand their activities at the existing location(s) rather than set up new ones.

The interviews showed that, on other aspects too, half of the participating social enterprises underwent a major change of direction in the past two years. This is partly inherent to successful entrepreneurship, in which unexpected events are considered opportunities, rather than threats (Sarasvathy, 2001). A number of the participating WISEs have changed their core activities during the course of this research, creating more diverse activities for the target group, or allowing new customers to be served better. Only a small minority of companies have succeeded in scaling up according to a strategic plan that was devised in advance. Often these are companies that have been around for a longer time and have their organization and governance structures in place. However, proportionally the size of their growth is often smaller than that of those companies that have undergone a change of direction.

Only four out of twenty companies failed to scale up at all. One of the main reasons for this seems to be a limited capacity to cope with financial setbacks, for example as a result of long-term absenteeism on key functions or other unforeseen costs. Often, these companies also struggle to reconcile social and economic value creation. Due to their limited size and small profit margins, these social enterprises have difficulties in overcoming unexpected financial blows. Moreover, prolonged crisis management leaves too little time for activities that could reverse this trend, such as acquisition, or more attention to strategy.

#### **4. Conclusions**

Scaling up is a complex process for any company because it involves changes in organization, working methods and sometimes objectives. Work-integration social enterprises differ in several important areas, not only with respect to for-profit enterprises but also with regard to social enterprises that focus on other societal impact areas. For instance, by working with specific target groups, WISEs have to have their human resource management in place from the very start, whereas other starting companies generally have to deal with these issues in a later stage and in a more organic fashion. Additionally, WISEs often have to deal with major differences in local contexts, for example with regard to the way in which the intake of the target group is organized. This makes it far from self-evident that their business model can be replicated elsewhere.

Nevertheless, this research shows that it is indeed possible for WISEs to scale up successfully and to increase their societal impact. Whether or not a social enterprise is able to scale up depends strongly on the way in which they deal with several barriers at the individual, organizational and external ecosystem level. An important precondition for scaling up is that, first and foremost, sufficient economic value is created. The pursuit of multiple value creation always creates tensions, but without a financially sound company it is not possible to create the intended societal impact. The most successful social enterprises in this project succeeded in acquiring substantial orders and structurally committing customers in order to achieve the desired societal impact.

A second precondition is a professional organization. Professionalization of the internal organization provides the necessary basis from which the social enterprise can grow further. The most successful social enterprises in this project demonstrated their ability to overcome the various obstacles they encountered at the start of the project. We observed that an organizational structure has been or is being built, in which the most important tasks are divided between several people, and where the day to day processes have been structured. These companies are no longer dependent on one person -usually the founder- but have a team of qualified people who keep the organization running and allow for the further expansion of the social enterprise.

This research shows that there are different routes to scale up and to reach more people with a distance to the labor market, but that this route often cannot be precisely planned in advance. Half of the participating social enterprises have succeeded in realizing growth only after adjusting one or more aspects of their business model. Changes in direction may be necessary when certain obstacles stand in the way of further growth, such as too little intake from the target group or the loss of an important customer. However, changes in direction can also be the result of unexpected events that offer new opportunities, such as new partnerships with other companies or municipalities. For most social entrepreneurs it is

not always that easy, however, to make adjustments to their business model along the way because their intended social long-term objective -participation of people at a distance from the labor market- can also (emotionally) stand in the way of drastic changes in direction.

## References

- Bloom, P. & Chatterji, A. (2009) Scaling Social Entrepreneurial Impact. *California Management Review*, 51(3), 114-133.
- Bosma, N., Schott, T., Terjesen, S., & Kew, P. (2016) *Global Entrepreneurship Monitor 2015: Special Topic Report Social Entrepreneurship*. Global Entrepreneurship Research Association.
- Clark, H. (2012) *Theory of Change: Value added and complementarity with Results-based Frameworks and Scorecards*. New York: ActKnowledge.
- Elkington, J., Hartigan, P., & Litovsky, A. (2010) 'From Enterprise to Ecosystem. Rebooting the Scale Debate' in Bloom, P. & Skloot, E. (eds.) *Scaling Social Impact: New Thinking*. New York: MacMillan, 83-102.
- Lyon, F. & Fernandez, H. (2012) Scaling Up Social Enterprise: Strategies Taken from Early Years Providers. *Working Paper 79*, Third Sector Research Centre.
- Martin, R. & Osberg, S. (2007) Social Entrepreneurship: The Case for Definition. *Stanford Social Innovation Review*.
- Nicholls, A. (ed.) (2006) *Social Entrepreneurship. New Models of Sustainable Social Change*. Oxford: Oxford University Press.
- Osterwalder, O., & Pigneur, Y. (2010) *Business Model Generation. A Handbook for Visionaries, Game Changers, and Challengers*. Hoboken: John Wiley
- Sarasvathy, S. (2001), Causation and Effectuation: Toward a Theoretical Shift from Economic Inevitability to Entrepreneurial Contingency. *Academy of Management Review*, 26(2), 243-263.
- Social Enterprise NL (2015) *De Social Enterprise Monitor 2015*. Amsterdam: Social Enterprise NL.
- Stam, E. (2015) 'Entrepreneurial Ecosystems and Regional Policy: A Sympathetic Critique'. *European Planning Studies*, 23(9), 1759-1769.
- UWV (2017) *Monitor Arbeidsparticipatie 2017. Aan het werk zijn, komen en blijven van mensen met een arbeidsbeperking*. Amsterdam: Uitvoeringsinstituut Werknemersverzekeringen
- Witkamp, M., Royackers, L., & Raven, R. (2011) From Cowboys to Diplomats: Challenges for Social Entrepreneurship in The Netherlands. *Voluntas*, 22, 283-310.

## Welcome in my backyard: how having good neighbours can help ending homelessness

Maarten Davelaar<sup>1</sup>, Lia van Doorn<sup>2</sup>, Aly Gruppen<sup>3</sup>, Jeroen Knevel<sup>4</sup>

<sup>1</sup>Centre for Social Innovation, HU University of Applied Sciences Utrecht, NL, <sup>2</sup>Centre for Social Innovation, HU University of Applied Sciences Utrecht, NL, <sup>3</sup>Centre for Social Innovation, HU University of Applied Sciences Utrecht, NL, <sup>4</sup>Centre for Social Innovation, HU University of Applied Sciences Utrecht, NL.

---

### **Abstract**

*With the goal of drawing lessons from collective mixed housing projects in Utrecht, the HU University of Applied Sciences Utrecht, created in partnership with care and housing providers a Community of Practice on Mixed Housing. Residents of housing projects, social workers, community builders and managers of housing associations, care providers and homeless organisations participated in this learning community. The research conducted within the framework of this Community of Practice reveals the positive impact of three projects housing ex-homeless people on the individual wellbeing of most inhabitants. Furthermore, the research underlines the potential of these innovative projects to scale up affordable and adequate housing for both (young) people entering the housing market and people previously depending on protected housing facilities, institutions or shelters. Lessons learned from the projects have been incorporated in (plans for) new mixed housing projects. These include a set of conditions under which mixed housing projects can help care providers, homeless services, housing corporations and local authorities to secure a good living environment for all – including those living close to these housing projects.*

**Keywords:** *Inclusive housing policies, collective mixed housing projects, homelessness, community building.*

---

## **1. Introduction**

In the Netherlands, the city of Utrecht is leading in providing adequate accommodation through mixed housing projects for ‘regular’ tenants and people previously living in homeless services or protected housing facilities. ‘New’ homeless persons also obtain the possibility for making a new start, instead of having to depend on shelters first. The concept of mixed housing, not to be confused with mixed income housing, relates in our definition to small and medium-sized (up to 500 residents) collective housing projects that are home to different groups of people, including more vulnerable and/or socially excluded groups. They intentionally live next to each other, connect and engage in joint activities.

In this paper, we examine in detail three projects, all with mainly self-contained dwellings: ‘Groene Sticht’ (since 2003), a small neighbourhood with 69 regular tenants and homeowners, and 35 ex-homeless persons; ‘Parana’ (2014), a purpose build complex with 24 regular and 44 (ex-)homeless individuals/families; ‘Majella Wonen’ (2016), older basic, post-war dwellings with 39 regular tenants and 35 homeless persons/families (see table 1 for an overview of the main characteristics of the housing projects and figure 1 for some images). These price-winning projects, co-created by a homeless service, social integration services and a social housing provider are built on an innovative concept of social management, with a high level of self-organisation. All residents are fully eligible members of the residents-committees and take responsibility for activities such as festivities, gardening, and the selection of new tenants. If necessary, ex-homeless inhabitants receive individualised support.

## **2. Research within the framework of a Community of Practice**

In 2016 a Community of Practice on mixed housing was created in Utrecht. It is best described as a learning community with residents of housing projects, social workers and community builders and policy makers and managers of housing associations, care providers and homeless organisations. The Community of Practice was facilitated by the Centre of Social Innovation of HU University of Applied Sciences. Research was conducted within the framework of this Community. We collected data (2016 -2018) through the participatory meetings of this Community of Practice on Mixed housing, the study of documents, in-depth interviews with inhabitants of the housing complexes, focus group-sessions with professionals and interviews with local stakeholders. The research findings were thoroughly discussed during the meetings of the learning community.

Our research focused on the following questions: what are social structures and mechanisms that could help create a socially sustainable, safe and attractive living environment for both regular tenants and more vulnerable populations? What obstacles seem to hamper inclusion and participation or create tensions between residents from different backgrounds? Could lessons learned from existing mixed housing projects be used to develop new projects and

improve policies aiming at creating more inclusive and welcoming neighbourhoods? In this paper we discuss in detail structures and mechanisms that help homeless people feel at home amidst their (new) neighbours and foster their social integration. In addition, we identify several tensions that hamper integration and analyse the ways in which both residents and professionals try to tackle these obstacles. We pay attention to the lessons learned in the Community of Practice and the ways in which new insights are implemented in the three housing projects mentioned before. We also describe how new understandings have influenced working practices in Place2BU, one of the latest, and up until now the largest, collective mixed housing project in Utrecht (see table 1 and figure 1). We will also describe how the Community of Practice and a newly created course for social workers, project managers and others working for mixed housing projects or planning to create new ones, generates ideas for the benefit of future mixed housing projects in particular, and inclusive housing policies in general.

### **3. Results and conclusions**

Our findings can be summarized as follows: first, these innovative projects increase the wellbeing of most inhabitants: people report ‘feeling at home’, less lonely and being accepted. The friendly interactions, mutual self-help and possibility to engage in activities are mentioned as valuable characteristics. Accordingly, the former homeless people, often also with a history of mental illness or addictions, tend to ask for support at an early stage, with the community functioning as a social ‘early warning system’. Furthermore, the research underlines the potential of these innovative projects to scale up affordable and adequate housing for both (young) people entering the housing market and people previously depending on protected housing facilities, institutions or shelters. Lessons learned from the projects have been incorporated in (plans for) new mixed housing projects. To end with, we identified conditions under which mixed housing projects can help care providers, homeless services, housing corporations and local authorities to secure a good living environment for all – including those living close to these housing projects. Crucial aspects seem to be the existence of a social management policy including a clear vision on self-organisation and community building, smart selection procedures with expectation-management to foster a realistic level of reciprocity and the availability of individualised professional support when needed.

### **4. Exchange of ideas and further research**

We are curious to hear from other examples and experiences related to integrative and inclusive developments in the social housing sector, including initiatives by tenants themselves. Based on our research we will search for follow up funding through national funds and European funds. For that purpose we hope to get in touch with researchers in the



CARPE-network who are interested in developing new proposals in the field of innovative, inclusive housing policies and practices.

**Table 1. Characteristics of some mixed housing projects in Utrecht<sup>1</sup>**

Mixed Housing projects in Utrecht	Regular tenants	Tenants from 'special target groups'	Type of dwellings	Facilities
't Groene Sticht (since 2003) Small neighbourhood in new large city district	69 (including families and single person households, 3 members Emmaus community and appr. 12 home-owners)	35 ex-homeless people (including 10 people living in the Emmaus community)	32 self-contained apartments, 9 rooms, 1 Emmaus-group, 9 owner-occupied properties	Offices for floating support workers, meeting spaces, garden, neighbourhood restaurant, second-hand shop
Parana (since 2014) Purpose build complex under architecture	24 (including students and young working people)	20 people in emergency services, 24 'multi-problem', ex-homeless people	48 apartments (one and two rooms, including bathroom and kitchen)	Communal kitchens, living rooms and rooftop garden, Kiosk, offices (24/7 staff)
Majella (since 2016) Older, basic, post-war dwellings	39 (mainly working people, few students)	35 ex-homeless people (including some families)	67 apartments (one and two rooms, plus bathroom and kitchen)	Office for floating support workers (will be transformed in 2020 into communal space), garden
Place2BU (since 2017) temporary, prefabricated, modular housing	360 (all under 27)	90 ex-homeless people and clients from supported housing schemes, 40 young refugees	490 apartments (including bathroom and kitchenette)	Small communal living room on each floor, large community centre, sports grounds, gardens

<sup>1</sup> Figures from 2018.



Figure 1. Mixed housing projects, clockwise from top left: Parana, Place2BU, 't Groene Sticht, Majella.

## References

Davelaar, M., Gruppen, A. & Knevel, J. (2018). *Goede buren. Lessen uit gemengde woonprojecten in Utrecht.* [Good neighbours. Lessons from mixed housingprojects in Utrecht.] Utrecht: Kenniscentrum Sociale Innovatie Hogeschool Utrecht.

## Arduino-based prototype to estimate heat stress indices in urban environments

Carlos Vargas-Salgado<sup>1</sup>, Lina Montuori<sup>2</sup>, Paula Bastida-Molina<sup>1</sup>, David Alfonso-Solar<sup>2</sup>

<sup>1</sup>Department of electrical Engineering, Universitat Politecnica de Valencia, Spain,

<sup>2</sup>Department of Applied Thermodynamics, Universitat Politecnica de Valencia, Spain.

---

### **Abstract**

*Thermal comfort indices are normally used for assessing and controlling heat stress conditions in both indoors and outdoors environment. In this paper, the results of the design and test of an Arduino-base prototype for estimating heat stress index is presented. This prototype allows the accurate detection of wind speed, air temperature, relative humidity, precipitation, atmospheric pressure, irradiation and globe thermometer temperature. By means of these parameters, it is possible to obtain indices such as mean radiant temperature (MRT) and wet bulb globe temperature (WBGT). As a result, the indices are estimated, stored in a database and analyzed. These values will be used in the future to measure the mitigation of heat stress in urban environments, by means of the construction of green facades, green roof or tree planting.*

**Keywords:** *Arduino; Heat stress index; globe temperature; WBGT; MRT.*

---

## 1. Introduction

Exposure to high-temperature environments can deviate in physical and psychological health problems (Deschenes, 2014), therefore, evaluating the relation between high temperature and health problems is an important task (Enander & Hygge, 1990; Fishman, Carrillo, & Russ, 2019; Gasparrini et al., 2017), even for urban planning (Gunawardena, Wells, & Kershaw, 2017). However, in general terms, assessing heat stress index is not an easy task due to environmental changing conditions depend on de location, and therefore, a standardized heat stress index monitor is required for the location to asses (Maurya, Haque, Kumar, & Diwakar, 2019). (V. H. Nguyen, Q. T. Tran, and Y. Besanger 2016).

On the other hand, several papers mentioned the use Arduino board as a monitoring system (A. D. Deshmukh and U. B. Shinde 2016, S. Ferdoush and X. Li 2014). The development of a low-cost SCADA system using an Arduino board is presented in (I. Allafi and T. Iqbal, 2018), where environmental variables and power generation from the photovoltaic system are measured. (J. L. Sarinda, T. Iqbal, and G. Mann 2017) presents the development of a system for remote wireless control and monitoring for a single power inverter. The hardware used by the authors includes an Arduino and a Raspberry development board.

This work presents and analyses the results of the design, commissioning and test of a prototype to measure continuously the parameter required to calculate MRT and WBGT for the purpose of carrying out actions to mitigate the heat stress.

## 2. Methodology

To measure parameters required for calculating heat stress indices, a low-cost heat stress monitor indices have been designed, built, commissioning and tested. The components used to set up the prototype are shown in table 1:

**Table 1: Components used to set up the prototype**

Component	Qty	Function
Arduino Mega	1	Microcontroller
DTH22	1	Relative humidity and Temperature sensor
DS18B20	3	Temperature sensor
JL-FS2	1	Cups anemometer 0-5 Vols
BME280	1	Pressure sensor
LCD2004 + LCN1602	1	Display
TPL5110	1	Timer

RTC DS1307	1	Real-time clock I2C
INA219	3	DC voltage and current sensor
INA3221	1	DC voltage and current sensor (Three-in-one sensor)
MH-RD	1	Rain sensor
C-0121 Cebek	1	PV Cell calibrated – Irradiation sensor
CNC 165x135 6 V	1	PV solar panel
DC-DC 5 V to 12 V	1	Boost converter 5 V to 12 V
DC-DC 2.5- 5 V to 5 V	1	2.5- 5 V to 5 V
TP4056	1	Battery charger
18650 Lanzhd	1	Li-Ion battery 2600 mAh
Micro SD TF Card Memory	1	Micro SD module

A scheme, developed in Fritzing, with the final design included all the components integrated into the assembly is shown in figure 1.

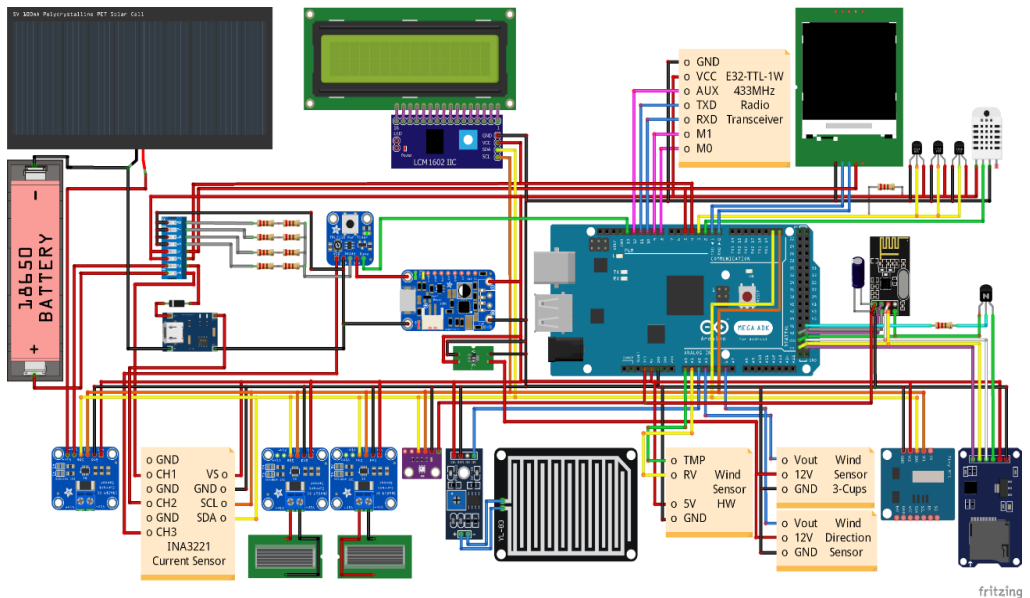

Figure 1. Scheme with the final design of the prototype developed in Fritzing. Source: fritzing (2019)

To integrate all the sensors in the Arduino board, a PBC board was designed and printed. For such purpose, the easyeda platform was used. The design obtained is shown in figure

2a. A picture of the PCB board with all the connectors and some sensors is shown in figures 2b and 2c.

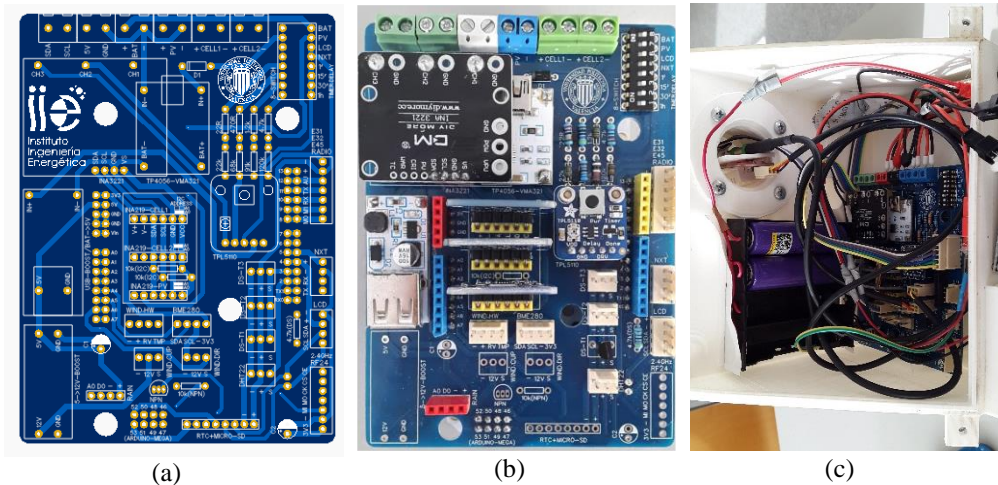

Figure 2. PCB design used easyeda. Board printed (a). Board with some components integrated (b, c)

Once the designed was carried out, the Arduino board is programmed. The program uses the libraries recommended by the manufactures of the sensors. The libraries used for programming the Arduino board are shown in figure 3.

```
LIBRERÍAS *****
*****
*/

#include <DHT.h> //DHT22
#include <OneWire.h> //DS18B20
#include <DallasTemperature.h> //DS18B20
#include <Adafruit_BME280.h> //BME280
#include <Adafruit_Sensor.h> //BME280
#include <Wire.h> //LCD, INA219, INA3221
#include <LiquidCrystal_I2C.h> //LCD
#include <Adafruit_INA219.h> //INA219
#include <SDL_Arduino_INA3221.h> //INA3221
#include <SoftwareSerial.h> //E32-TTL-1W
#include <RTCLib.h> //RTC
#include <SD.h> //microSD
#include <SPI.h> //microSD

#include "defines.h" //Archivo de constantes de programa
```

Figure 3. Libraries used in the Arduino code. Source: Arduino (2019)

One of the components of the system is a microSD card, used for storing all the data collected by the sensors. To save energy, the timer TPL5110 is in charge of running the program every 15 minutes to collect all the data from the sensors, when the data are stored into the microSD card, the program turns off the Arduino until the TPL5110 turn it on again after 15 minutes. The prototype does not require being connected to an AC power plug, since it has a PV panel which, by means of a charger, charges the 18650 battery, then, the system can continue operating at night. One part of the code used for programming the Arduino board is shown in figure 4.

```
// INICIALIZACIÓN DE SENSORES Y PERIFÉRICOS *****

// SERIAL MONITOR *****
Serial.begin(115200);

// DHT22 (HUMIDITY AND TEMPERATURE SENSOR) *****
dht.begin();

// DS18B20 (DIGITAL TEMPERATURE SENSORS) *****
ds18b20.begin();

// BME280 (PRESSURE AND BAROMETER SENSOR) *****
bme.begin(0x76);

// INA219, INA3221 (CURRENT AND VOLTAGE SENSOR) *****
ina3221.begin();
ina_cell.begin();
ina_cell2.begin();
ina_pv.begin();

//INA219 by default will use the largest range (32V, 2A). You can call a setCalibration function to change this range:
//ina.setCalibration_32V_1A(), ina.setCalibration_16V_400mA()
ina_cell.setCalibration_16V_400mA();
ina_cell2.setCalibration_16V_400mA();

// LCD_2004A + LCN1602 (LCD 20x4 I2C) *****
pinMode(LCD_EN, INPUT);
lcd.init(); //initialize the lcd
lcd.backlight(); //open the backlight
lcd.clear();

// TPL5110 (POWER TIMER BREAKOUT) *****
pinMode(TPL_DONE, OUTPUT);
digitalWrite(TPL_DONE, LOW);

// E32-TTL-1W (433MHz RADIO/WIRELESS TRANSCIEVER) *****
pinMode(RF_M0, OUTPUT);
pinMode(RF_M1, OUTPUT);
pinMode(RF_AUX, INPUT);
radio.begin(9600);

//Modos de funcionamiento - Normal: M0=0 M1=0 / Wake-up: M0=0 M1=1 / Power saving: M0=1 M1=0 / Sleep: M0=1 M1=1
digitalWrite(RF_M0, HIGH);
```

Figure 4. Part of the code used for programming the Arduino board Arduino (2019)

Once the prototype has been assembled and tested, it was required to design a box for the prototype. Figure 5 shows the box designed in a 3D printer by means of the tinkercad platform. Figure 6 shows a picture of the final box and its components.



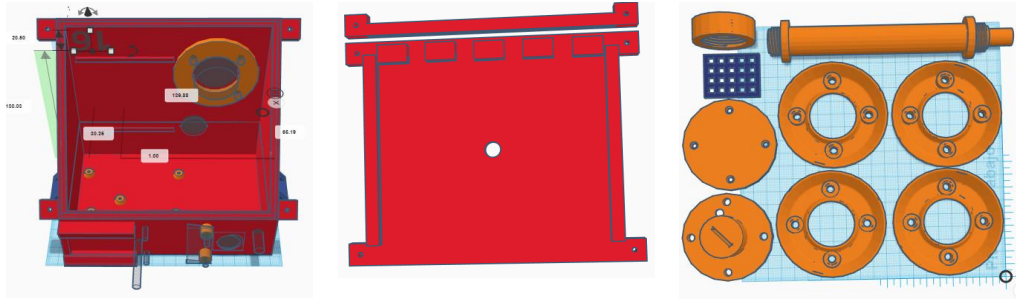

Figure 5. Prototype box designed for the assembly. Source: tinkercad (2019)

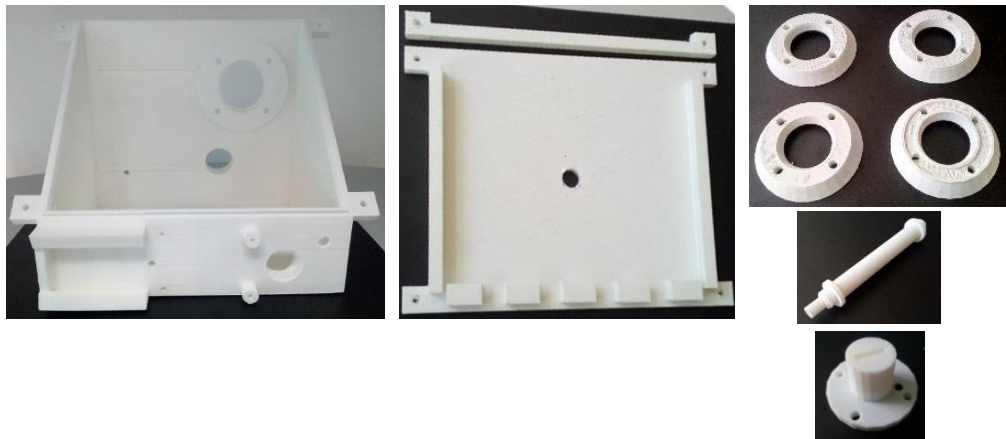

Figure 6. Printed parts of the prototype box

According to NTP 322, WBGT index calculation for outdoor (with solar irradiance) environments is carried out by Equation 1.

$$WBGT_{outdoor} = 0.7t_{nwb} + 0.2t_g + 0.1t_a \quad \text{Equation 1}$$

Mean radiant temperature (MRT)  $\bar{t}_r$  is calculated according to (UNE ISO 7726, 2002) using Equations 2. (For forced convection when globe diameter is equal to 15 cm).  $\bar{t}_r$  depend on the globe temperature  $t_g$ , the wind velocity  $v_{wind}$ , and the air temperature  $t_a$ .

$$\bar{t}_r = \left[ (t_g + 273)^4 + 2.5 \times 10^8 x (v_{wind})^{0.6} (t_g - t_a) \right]^{1/4} - 273 \quad \text{Equation 2}$$



### 3. Results

As a result, a device able to monitoring heat stress indices was obtained. The final design is shown in figure 7.



Figure 7. Prototype final design

Data are collated and exported to an excel file to be processed. An example of the data obtained are shown in table 2.

**Table 2. Data collected from the microSD card**

Date	HR %	Ta (°C)	Tbox (C°)	Tg (°C)	Patm (Pa)	IRR (W/m <sup>2</sup> )	RAIN	Vwind (m/s)
13/02/2019 18:30	71,36	13,8	13,61	15,4	103155	3,33	0	0,43
13/02/2019 18:45	73,34	13,52	13,24	14,21	103097	0,83	0	0,84
13/02/2019 19:00	73,99	13,4	13,06	13,39	103115	0,38	0	0,88
13/02/2019 19:15	76,48	13,3	12,93	12,89	103131	0,31	0	0,66
13/02/2019 19:45	77,38	13,19	12,8	12,55	103155	0,31	0	1,32
13/02/2019 20:00	77,11	13,05	12,62	12,37	103158	0,34	0	0,21
13/02/2019 20:15	81,08	13,06	12,61	12,19	103167	0,31	0	0,55
13/02/2019 20:30	81,24	13	12,56	12,13	103180	0,34	0	0,74
13/02/2019 20:45	83,36	12,9	12,49	12,08	103189	0,31	0	0,46
13/02/2019 21:00	84,17	12,69	12,25	12,01	103206	0,31	0	0,34

13/02/2019 21:15	85,95	12,42	12,05	11,81	103216	0,31	0	0,44
13/02/2019 21:30	83,96	12,3	11,87	11,55	103214	0,38	0	0,22

The device has been tested since February 2019, but due to the big amount of collated data, to analyze the results, 15th and 17th of February were chosen.

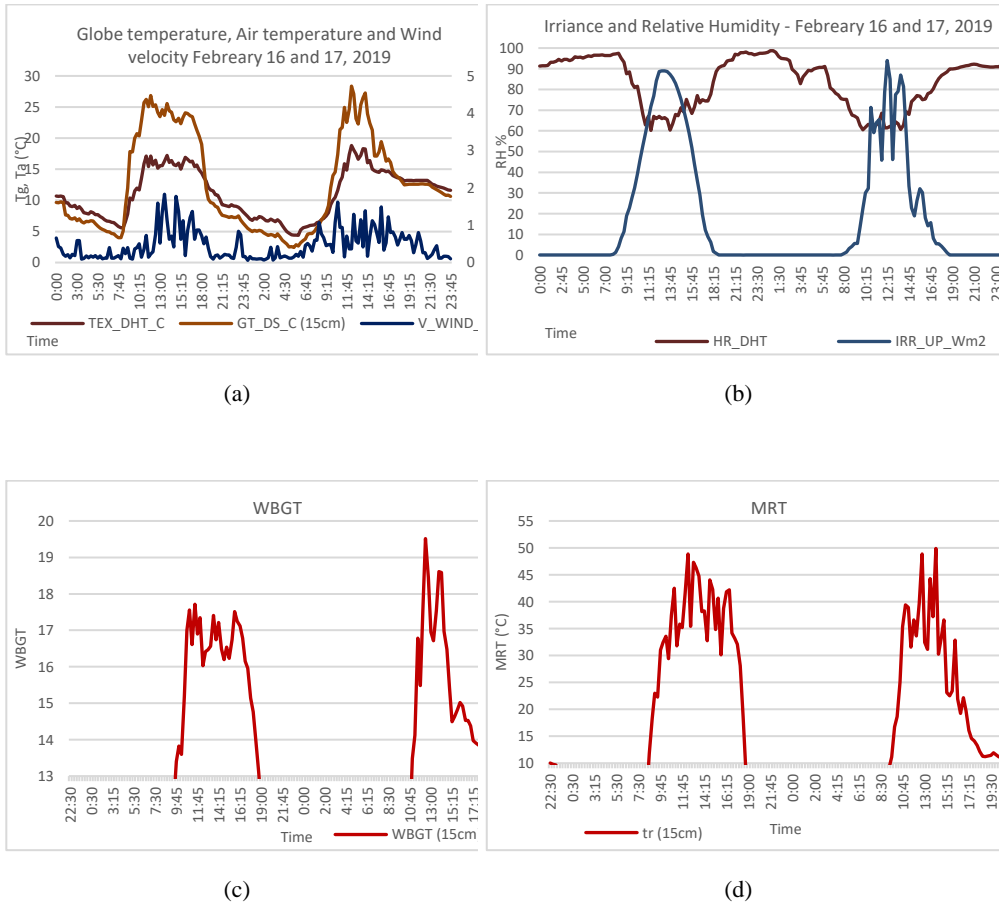

Figure 8. Collected data on February 16 and 17, 2019. Air temperature, Globe temperature and wind velocity (A), relative humidity and solar irradiance (b), WBGT (c) and MRT (d)

The designed prototype is able to measure continuously parameters such as Air temperature, Globe temperature, wind velocity, relative humidity, solar irradiance and atmospheric pressure (figure 8a and 8b). By means of the parameters measured it is possible to calculate heat stress indices such as WBGT and RMT (figures 8c and 8d).

## 4. Conclusion and discussion

Using the prototype designed and tested, two of the most important heat stress indices were calculated: WBGT and RMT. The values obtained let assess the level of heat stress in the areas under study. Knowing the level of heat stress, measures could be taken to alleviate it and improve the quality of life of the people affected. Depending on the results obtained by the prototype, some of the measures to mitigate heat stress are the installation of green facades, green roof, and tree planting. After setting up such components, by mean of the device designed, it is possible the quantification of the effect due to the improvements carried out.

## 5. Acknowledgements

This work was supported by European Commission through GROW GREEN project (Agreement number: 730283 — GROW GREEN — H2020-SCC-2016-2017/H2020-SCC-NBS-2stage-2016. <http://growgreenproject.eu/>)

This work was supported in part by the regional public administration of Valencia under the grant ACIF/2018/106.

## References

- Arduino (2019) [Software]. Recuperado de <https://www.arduino.cc/en/main/software>
- A. D. Deshmukh and U. B. Shinde, “A low cost environment monitoring system using raspberry Pi and arduino with Zigbee,” in 2016 International Conference on Inventive Computation Technologies (ICICT), 2016, pp. 1–6.
- Deschenes, O. (2014). Temperature, human health, and adaptation: A review of the empirical literature. *Energy Economics*, 46, 606–619. <https://doi.org/10.1016/j.eneco.2013.10.013>
- Enander, A. E., & Hygge, S. (1990). Thermal stress and human performance. *Scandinavian Journal of Work, Environment and Health*, 16(SUPPL. 1), 44–50. <https://doi.org/10.5271/sjweh.1823>
- Fishman, R., Carrillo, P., & Russ, J. (2019). Long-term impacts of exposure to high temperatures on human capital and economic productivity. *Journal of Environmental Economics and Management*, 93, 221–238. <https://doi.org/10.1016/j.jeem.2018.10.001>
- Gasparri, A., Guo, Y., Sera, F., Vicedo-Cabrera, A. M., Huber, V., Tong, S., ... Armstrong, B. (2017). Projections of temperature-related excess mortality under climate change scenarios. *The Lancet Planetary Health*, 1(9), e360–e367. [https://doi.org/10.1016/S2542-5196\(17\)30156-0](https://doi.org/10.1016/S2542-5196(17)30156-0)
- Fritzing (2019) [Software]. Recuperado de <http://fritzing.org/home/>

- Gunawardena, K. R., Wells, M. J., & Kershaw, T. (2017). Utilising green and bluespace to mitigate urban heat island intensity. *Science of the Total Environment*, 584–585, 1040–1055. <https://doi.org/10.1016/j.scitotenv.2017.01.158>
- I. Allafi and T. Iqbal, “Low-Cost SCADA System Using Arduino and Reliance SCADA for a Stand-Alone Photovoltaic System,” *J. Sol. Energy*, vol. 2018, pp. 1–8, 2018.
- J. L. Sarinda, T. Iqbal, and G. Mann, (2017) “Low-cost and open source SCADA options for remote control and monitoring of inverters,” *Can. Conf. Electr. Comput. Eng.*,
- Maurya, P. K., Haque, N., Kumar, R., & Diwakar, R. (2019). SELECTING A SUITABLE HEAT STRESS INDEX TO PROTECT CATTLE AND, (March), 18–21.
- V. H. Nguyen, Q. T. Tran, and Y. Besanger, “SCADA as a service approach for interoperability of micro-grid platforms,” *Sustain. Energy, Grids Networks*, vol. 8, pp. 26–36, Dec. 2016.
- S. Ferdoush and X. Li, “Wireless Sensor Network System Design Using Raspberry Pi and Arduino for Environmental Monitoring Applications,” *Procedia Comput. Sci.*, vol. 34, pp. 103–110, Jan. 2014.
- Tinkercad (2019) [Software]. Recuperado de <https://www.tinkercad.com/dashboard>

## Potential of landfill biogas production for power generation in the Valencian region (Spain)

Carlos Vargas-Salgado<sup>1</sup>, Jesús Águila-León<sup>2</sup>, Cristian Chiñas-Palacios<sup>2</sup> Lina Montuori<sup>3</sup>

<sup>1</sup>Department of electrical Engineering, Universitat Politècnica de Valencia, Spain,

<sup>2</sup>University of Guadalajara, Mexico, <sup>3</sup>Department of Applied Thermodynamics, Universitat Politècnica de Valencia, Spain.

---

### **Abstract**

*Landfills are still one of the most common ways to dispose solid urban waste in many countries due to their relatively simple technical requirements, operational costs and low investment. Moreover, biogas produced in landfills can be used as a renewable energy source for power generation. The Valencian region is one of the largest solid urban waste producers in Spain, and therefore, it may have an unexplored potential of landfill biogas production. This paper aims to estimate the landfill biogas production and its power generation potential for the Valencian region to provide related information about the use of landfill gas as an alternative source of energy. Statistical data from urban solid waste in landfills were gathered from the provinces of Alicante, Castellon, and Valencia, then the assessment of landfill biogas production was estimated by means of waste classification and disposal for each province. Results presented in this work show that the Valencian region has an important potential to use landfill biogas from solid urban waste as a renewable source for power generation, and also provide insights in valuable information to the Spanish government, academic researches, policymakers, and possible investors.*

**Keywords:** *Solid urban waste management; landfill biogas; bioenergy potential; power generation; renewable energy; Valencian region.*

---

## **1. Introduction**

A dump is a place where Urban Solid Waste (USW) is deposited. If there is no type of control in these dumps, the containing waste can cause foul smells, pollute nearby waters, be a focal point for rodents and insects, produce emissions of Greenhouse Gases (GHG) into the atmosphere and provoke fires due to the combustion of the combustible gas with high methane concentration resulting from the decomposition of the rubbish (Igliński, Buczkowski, & Cichosz, 2015).

Landfills, on the other hand, are places to prevent pollution, help the environment and protect human's health. Trash deposited on landfills is covered to prevent odors and to stop trash from flying away. Biogas is obtained by trash decomposing. The landfill gas is collected in pipes and recycled into fuel and later it could produce electricity. Its main components are methane (40-70% of CH<sub>4</sub>) and carbon dioxide (30-60% of CO<sub>2</sub>) in addition to other gases (1-5% of H<sub>2</sub>, N<sub>2</sub> or H<sub>2</sub>SO<sub>4</sub>). The gas composition depends on weather conditions, landfill characteristics or waste composition and treatment (Nadaletti et al., 2015). It is also important to emphasize that methane is the second largest contributor to global warming among GHG, after carbon dioxide.

Biogas can be used to generate electricity by using an internal combustion engine coupled to an electric generator. Many worldwide studies have reported detailed information about the estimates of power potential from biogas in landfills sites in several countries, such as Brazil, Bolivia, Mexico, and Poland (Igliński et al., 2015; Lima et al., 2018; Rios & Kaltschmitt, 2016; Vargas Bautista & Calvimontes, 2017).

### ***1.1. Solid waste in the Valencian Region***

Waste management has increasingly become in one of the main society challenges nowadays, given its growing generation and great environmental, social and economic impact. According to the Institute for Diversification and Energy Savings (Instituto de Diversificación y Ahorro de Energía – IDAE), in Spain, each citizen approximately generates about 1,5 kg of SUW per day (Diversificación y Ahorro de Energía, Armengol, & Farré, 2011). In the Valencian region, around 21 million tons of USW are generated every year (a 47 % in Valencia, 41% in Alicante and 12% in Castellón). The average generation per capita is about 1,2 kg of solid waste per day. (Infraestructuras Territorio y Medio Ambiente, 2012). Table 1 shows the annual solid waste generated in the Valencian region.

**Table 1. The annual solid waste generated in the Valencian region (2016 to 2019).**

Year	Amount of solid waste (tons)		
	Alicante	Castellon	Valencia
2016	1.099.004	315.398	1.233.681
2017	1.098.186	315.163	1.232.762
2018	1.097.240	314.892	1.231.701
2019*	1.096.167	314.584	1.230.496

Source: (Infraestructuras Territorio y Medio Ambiente, 2012).

\*Estimated value

### 1.1.1. Composition of the solid waste

According to the conselleria de infraestructura fo Valencia Region, the main elements that make up the characterization of solid waste in the region of Valencia are 41% organic matter, 29% packaging and 30% other materials. The total of packaging composition is represented by 41% plastic, 22% paper, 19% glass, 13% metals and 5% cardboard. For the total composition of others: 42% paper & cardboard, 9% plastic, 5% metals, 1% glass, 11% ground & ashes, 3% wood and 15% others. The average estimate of composition is shown in Figure 1.

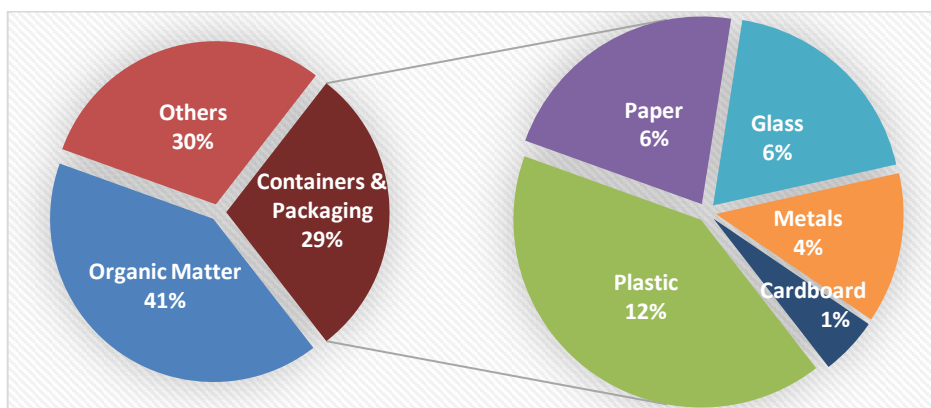

Figure 1 Average composition of the solid waste in the Valencian region. Source: (Consellería de Infraestructuras, 2013).

In this paper will be carried out the estimation of power generation from the biogas produced from the solid urban waste in the landfills of the provinces of Alicante, Castellon, and Valencia, and the reduction of emission of  $CO_2$ . For such purpose, an economic model for the evaluation and feasibility of the project will be used.

## 2. Methodology

Two models were applied to estimate the use of biogas for the Valencian region; the first estimates the production of biogas and the second estimates the generation of electricity from biogas. Data from 2012 to 2015 were used for a prediction over the year 2026. Once the predictions were produced, the results were tabulated and compared against the estimates of energy demand and USW production of the Valencian region. According to (Sanchís, 2019) currently in the Region of Valencia there are three main operating landfills; Onda in the province of Castellon, filled since 2014, Dos Aguas (in Phase 2), in the province of Valencia which has been active since 2010 and with a current lifespan of 5,6 years being at 51,7% of its capacity, and finally the Alicante landfill, active since 2005, with a last life of 4,75 years being at 82,3% of its capacity. For simplification purposes, this work raises the scenario that the production of biogas in the Valencian Region depends entirely on these three landfills and since their lifetime is about to be exhausted. It is supposed that before 2024 will be opened at least three landfills with equal capacity to the current ones to cover the needs of trash disposal. Such landfills also ensure an increment in the biogas production in the future.

### 2.1. Prediction Model of Landfill Biogas

The composition of biogas depends on: the characteristics and volume of the residue, moisture, compaction and age of the landfill. The generation of biogas emissions varies over time and with environmental conditions, so there are several models for estimating the generation of biogas in landfills. In this work the biogas generation potential per year was calculated using the Landfill Gas Emission Model (LandGEM) of the U.S. Environmental Protection Agency (EPA). LandGEM first-order degradation model has been implemented obtaining good results about landfill gas emission rate per year (Vargas Bautista & Calvimontes, 2017). Its formula is shown in Eq. 1.

$$Q = 2 \sum_{i=1}^n kL_0M_i e^{-kt_i} \quad \text{Equation 1}$$

Where  $Q$  is the total landfill biogas emission rate per year ( $m^3/y$ ),  $n$  is the number of years of waste placement,  $k$  is the landfill gas generation rate constant ( $y^{-1}$ ),  $M_i$  is the mass in mega grams of the solid waste section placed in year  $i$  ( $Mg$ ),  $L_0$  is the methane generation potential ( $m^3/Mg$ ) and  $t_i$  is the age of the waste section placed in year  $i$  ( $y$ ). The Equation 1 model was applied using USW data from the Valencian region from the years 2013 to 2016 as inputs.

### 2.2. Prediction Model for Power Generation

The process for power generation consists in extracting the biogas from the landfill through a series of pipes that transport it to a storage tank. Once the annual biogas production data is



obtained, the next step is to calculate the electricity generation from the burning of biogas in an internal combustion engine. A simple model that suggests the calculus of potential electricity generation from landfill biogas is shown in Equation 2.

$$PG = Q \cdot LHV \cdot \eta \quad \text{Equation 2}$$

Where  $PG$  is the power generation potential from landfill biogas per year ( $GWh/y$ ),  $Q$  is the total landfill biogas emission rate per year, also known as the volumetric flow of methane ( $m^3/y$ ),  $LHV$  is on average  $18.54 \text{ MJ/m}^3$  representing the lower heating value of methane and  $\eta$  is the conversion efficiency from biogas to electricity by a combustion engine generator, assumed to be 34% at 80% of the rated power, according to (Vargas Bautista & Calvimontes, 2017). Table 2 summarizes the assumptions made for the variables used in gas emission rate and power generation per year.

**Table 2. Parameters to evaluate the landfill biogas and power generation.**

Parameter	Assumed value
$L_o, m^3/Mg$	100 – 180
$k, y^{-1}$	0,05
Collection efficiency	80%
Methane generation from biogas	50%
Methane LHV (low heating value), $MJ/m^3$	18,54

Source:(Vargas Bautista & Calvimontes, 2017).

Equation 2 model was applied using data obtained for the Valencian region from the period 2013 to 2016 and the annual estimation of the USW in the three provinces to obtain the amount of electricity generation from biogas formula. Also, an electric generation projection is made with the annual cost of the energy generated.

### 3. Results

Results of applying the previously proposed biogas production and power generation models from Equation 1 and Equation 2 were obtained. It is noticed that the production of biogas from 2016 to 2026 remains invariable. While biogas production slowly decreases, new landfills should be created to cover the needs of trash disposal, preserving the production of biogas. Figure 2 shows the estimated biogas production for each of the provinces of the Valencian Region under the scenario raised. A landfill creation is proposed in Castellón by 2020, in Alicante for 2023 and in Valencia by 2025, according to the order of its useful term of life. Average annual production of 2,499 megagrams of biogas is estimated for the Valencia Region from 2020 to 2032.

Figure 3 shows the estimate of power generation from landfill biogas from 2020 to 2032, as well as contributions to that power from each province of the Valencian Region. As is shown in Figure 3, if three landfills of at least the capacity of Onda, Dos Aguas and Alicante are opened before these are filled in the next 6 years, then from 2020 to 2032 there would be an average annual generation potential of 6,37 GWh/year, (Average total demand in the Valencian Region is 22138 GWh/year).

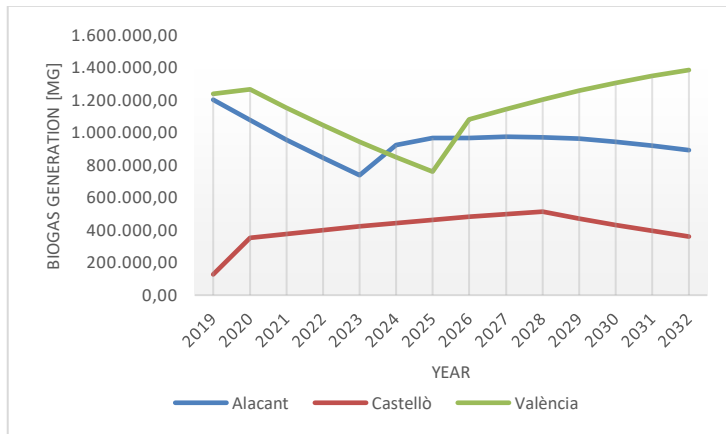

Figure 2 Annual electricity potential power generation from landfill biogas projections from the years 2020 to 2032.

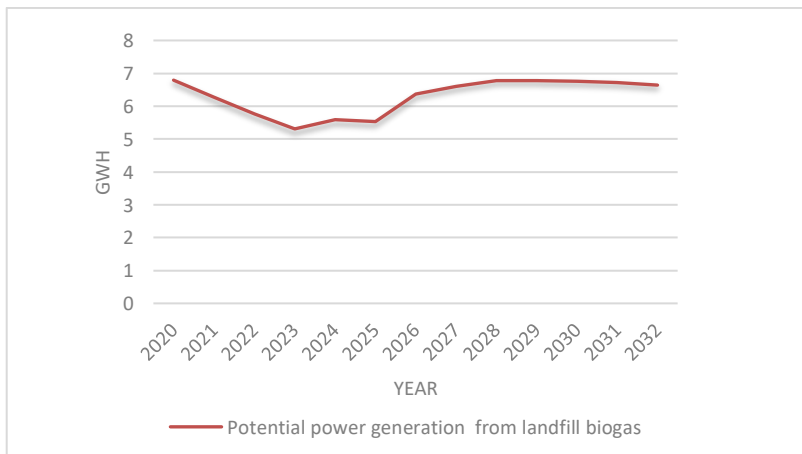

Figure 3 Annual electricity potential power generation from landfill - biogas projections from the year 2020 to 2032.

As of 2011, its inhabitants generated 5.9 tons of CO<sub>2</sub> per capita per year in the Region of Valencia, (“Cada valenciano emite dos toneladas de CO<sub>2</sub> menos que el conjunto de la media

nacional”). Using data obtained from biogas production and power generation it can be estimated the number of equivalent tons of CO<sub>2</sub> that could be saved by leveraging the biogas production for power generation. Figure 4 shows the possible contribution in carbon equivalent tons obtained from biogas generation against the total estimated carbon equivalent tons of the Valencian Region according to (Valencia Plaza, 2017). On average, according to the results shown in Figure 4, from 2020 to 2032, a reduction of 8% to the total of the equivalent carbon tons would be obtained.

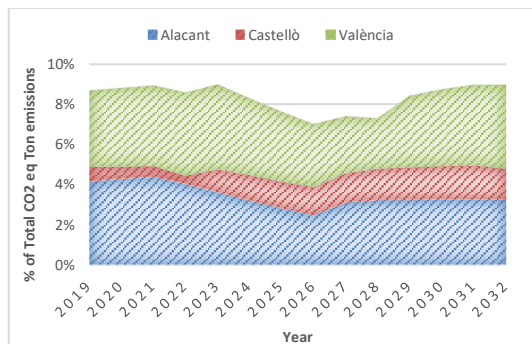

Figure 4 (a) Equivalent tons of carbon saving from biogas related to total equivalent tons of carbon of the Valencian Region.

#### 4. Discussion

The results of this work show that while the percentage of estimated power generation from biogas under the scenario proposed is little compared to the estimated total energy demand of the Valencian Region, 6.5 GWh/year vs. 21,965 GWh/year on average, for the next few years, that generation could result in a significant reduction in greenhouse gas emissions, as approximately 8% of the Valencian Region's total carbon-equivalent ton emissions could be used in power generation from biogas, rather than the use of other energy sources as fossil fuels.

#### References

- Cada valenciano emite dos toneladas de CO<sub>2</sub> menos que el conjunto de la media nacional. (n.d.). Retrieved June 27, 2019, from [https://www.elperiodic.com/cada-valenciano-emite-toneladas-menos-conjunto-media-nacional\\_133099](https://www.elperiodic.com/cada-valenciano-emite-toneladas-menos-conjunto-media-nacional_133099)
- Consellería de Infraestructuras, T. y M. A. (2013). Análisis y diagnóstico de los RSU de la Comunidad Valenciana. *Plan Integral de Residuos de La Comunidad Valenciana*, 149. Retrieved from <http://www.citma.gva.es/documents/20549779/161513659/02.+Residuos+urbanos/57c112cf-563b-4c09-8c2a-070b2d968d19>
- Diversificación y Ahorro de Energía, I., Armengol, G., & Farré, O. (2011). Situación y potencial de valorización energética directa de residuos. Estudio técnico PER 2011- 2020. *Plan de Energías*

*Renovables, España*, 1–134.

- Igliński, B., Buczkowski, R., & Cichosz, M. (2015). Biogas production in Poland - Current state, potential and perspectives. *Renewable and Sustainable Energy Reviews*, *50*(2015), 686–695. <https://doi.org/10.1016/j.rser.2015.05.013>
- Infraestructuras Territorio y Medio Ambiente, C. (2012). Análisis de la situación y gestión de los residuos en la Comunitat Valenciana. Valencia.
- Lima, R. M., Santos, A. H. M., Pereira, C. R. S., Flauzino, B. K., Pereira, A. C. O. S., Nogueira, F. J. H., & Valverde, J. A. R. (2018). Spatially distributed potential of landfill biogas production and electric power generation in Brazil. *Waste Management*, *74*, 323–334. <https://doi.org/10.1016/j.wasman.2017.12.011>
- Nadaletti, W. C., Cremonese, P. A., De Souza, S. N. M., Bariccatti, R. A., Belli Filho, P., & Secco, D. (2015). Potential use of landfill biogas in urban bus fleet in the Brazilian states: A review. *Renewable and Sustainable Energy Reviews*, *41*, 277–283. <https://doi.org/10.1016/j.rser.2014.08.052>
- Rios, M., & Kaltschmitt, M. (2016). Electricity generation potential from biogas produced from organic waste in Mexico. *Renewable and Sustainable Energy Reviews*, *54*, 384–395. <https://doi.org/10.1016/j.rser.2015.10.033>
- Sanchís, J. (2019). Los principales vertederos de la Comunitat se saturarán en apenas seis años | Las Provincias. Retrieved June 27, 2019, from <https://www.lasprovincias.es/comunitat/principales-vertederos-comunitat-20190109004944-ntvo.html>
- Valencia Plaza. (2017). Las empresas de la Comunitat Valenciana han emitido gases por valor de más de 42 millones de euros - Valencia Plaza. Retrieved June 27, 2019, from <https://valenciaplaza.com/las-empresas-de-la-comunitat-valenciana-han-emitido-gases-por-valor-de-mas-de-42-millones-de-euros>
- Vargas Bautista, J. P., & Calvimontes, J. (2017). Evaluation of Landfill Biogas Potential in Bolivia To Produce Electricity. *Investigacion & Desarrollo*, *17*(1), 55–62. <https://doi.org/10.23881/idupbo.017.1-5i>

## Fostering innovation at University of Debrecen

Péter Popovics<sup>1</sup>, Lilla Jutkusz<sup>2</sup>, Károly Pető<sup>3</sup>, Zoltán Szakály<sup>4</sup>, Zoltán Bács<sup>5</sup>

<sup>1</sup>Institute of Applied Economics Sciences, University of Debrecen, Hungary, <sup>2</sup> Chancellery, University of Debrecen, Hungary, <sup>3</sup>Institute of Rural Development, Tourism and Sports Management, University of Debrecen, Hungary, <sup>4</sup>Institute of Marketing and Trade, University of Debrecen, Hungary, <sup>5</sup> Institute of Accounting and Finance, University of Debrecen, Hungary.

---

### **Abstract**

*The aim of our writing is to present the opportunities offered by the University of Debrecen to students and researchers for the further development of innovative ideas in the marketplace, and to identify the essential linking elements of the university's innovative environment that can have an impact based on mutual benefits from local, regional, national and international levels.*

*The University of Debrecen's Innovation Ecosystem Center (IEC) is an organization that is constantly evolving to meet the needs of the university in terms of innovation, development of corporate cooperation and technology transfer. It aims to promote industrial exploitation of research results and promote the introduction of ideas into the market. It is one of the tasks of the IEC - in line with what was said at the World Economic Forum in 2018 - to spread the entrepreneurial mindset, to strengthen corporate relations and to take a positive social impact approach to innovation processes.*

*To help the University of Debrecen to fully fulfil its mission of innovation and its visibility and recognition from the local to the international level, thereby contributing to the wider (market) exploitation of university ideas, and contributing to the cooperation between the competitive and governmental sectors. For the development of the local economy and for addressing environmental-socio-economic challenges, it is essential to provide a professional environment in an incubation center that meets the demands of the 21st century*

**Keywords:** *Innovation; Entrepreneurship; Incubation; Innovation Centre; Start-up ecosystem.*

---

## **1. Introduction**

Higher education is facing significant changes worldwide, leading to the emergence of new institutional models of operation in recent decades. Besides the aspects of sustainable funding, there are several triggering factors for adjusting the provision of educational, research and other services to changing conditions and market needs: accelerating change in science and technology, increased competition for innovation, globalization and internationalization, the emerging need for practice-oriented training and the widespread lifelong learning (Barakonyi, 2014).

To provide quality services, diversification of funding has become inevitable. In addition to the budgetary resources provided as normative support based on the number of students, typically higher education institutions have access to additional government and community budgetary resources through tenders for institutional development and research activities. Intensifying relations with external (economic) actors is a new opportunity that may contribute both to the expansion of available financial resources and to the harmonization of higher education services with market expectations. External actors as collaborating partners, costumers of educational and R&D services or entities exploiting the R&D results achieved through technology transfer can provide additional financial (and human) resources and expertise to higher education institutions.

In addition to funding issues, the strengthening the role of higher education institutions in R&D and its contribution to local economic development and society is strongly reflected in EU and national strategic goals. In Hungary, the government strategy also explicitly identifies higher education institutions as the “most important scientific, professional and organizational actors in domestic R&D&I”: with regard to the third mission activities, “strengthening the impact of higher education in local economic development” and within this framework, creating favourable conditions to innovation (strengthening technology transfer, incubation and other related services), reinforcing social innovation and strengthening the service function will be of priority (Magyar Közlöny (2013), Stratégia (2016), Stratégia (2017)).

Depending on operational frameworks, industry relations and experience in innovation management, European higher education institutions will pursue different strategies and provide different services as third mission activities are concerned. There are several higher education institutions offering profit oriented services: operating incubators, innovation and research centers or participating in clusters (Deés, Sz. (2011)).

## 2. Innovation activities at the University of Debrecen

The University of Debrecen has been striving to respond appropriately to emerging challenges and make the most out of the opportunities arising from the changes in its operating environment since 2005 in many areas, including exploitation of the university's R&D results, encouraging university citizens to implement their innovative ideas, strengthening educational and research links with economic actors; and offering educational, cultural and sporting programs to local, regional communities.

The *technology and knowledge transfer* activities have a history of more than a decade: the legal predecessor of the Research Exploitation and Technology Transfer Center (hereinafter referred to as technology transfer office, TTO) was established in 2006 and since 2008 this unit has been responsible for utilizing the research results created at the University. Other key activities of the TTO include intellectual property protection consulting, managing the university's intellectual property portfolio, licensing marketable technologies, supporting other forms of exploitation, and preparing and negotiating the University's R&D service agreements with partners.

In 2018, the TTO portfolio was extended to the implementation of the Proof of Concept program (see: Figure 1.), funded from own institutional revenues, to promote the exploitation of R&D results. Building on international experience, the program provides resources to increase the level of technology development of early-stage, university-related ideas and inventions and to support the commercialization of university-generated technologies (gap funding). The aim of the program is to accelerate the exploration of the utilization potential of the research results generated at the University of Debrecen, the setting a utilization roadmap and defining the utilization process in order to reach new milestones in product or service development and testing. It also contributes to reducing the risk of introducing the innovative technology or product and thus making university technologies more attractive to market players. In addition to examining the technological / physical feasibility, mentoring and support activity includes – where appropriate – the examination of marketability and commercial feasibility and the identification of opportunities to engage in follow-on funding (POC, 2018). The researchers involved in the program will receive ongoing technical support both on the innovation process from TTO and on the aspects of marketability and necessary modification to enter the market from industry experts.



Figure 1. A "Proof of concept" in the innovation process. Source: POC (2018).

In order to explore and further develop the ideas, a specific call for proposals will be opened for students and young researchers in 2020 within the framework of the POC program, and students will also be able to develop their innovation ideas in a so-called fab-labs. In these open labs, students will access tools for design, modelling, electronics at the core facilities or divisions of the university (such as a 3D printer, food innovation lab, electrical engineering lab, etc.). Students will also be offered professional support from the university department's researchers and technical staff in order to deepen their professional and R&D management knowledge and gain access to international knowledge base.

The fab-lab is based on the free flow and sharing of ideas and provides opportunities for students to join multidisciplinary teams. Fab-labs can make a significant contribution to evolving innovation ecosystem for students and young researchers and increasing the number of start-ups.

The complexity of the programs starting in 2020 is completed with a scholarship program that promotes the discovery of students' innovative ideas at the university and supports the validation, development and prototyping of ideas, being combined with a training program for developing entrepreneurial competencies of talented students and innovative entrepreneurs.

The *promotion of the entrepreneurial mindset* and the implementation of activities aimed at developing related competences have also been part of the university's training portfolio for nearly a decade. On the one hand, the TTO provides students with detailed information on the innovation process, and on the other hand, specific, credit-based training courses of entrepreneurship are available to students.

Team Academy Debrecen was launched in 2010. The mission of the program is to provide business training that develops entrepreneurial mindsets and self-awareness through practice-oriented and innovative approaches to the requirements of the modern age, creating opportunities for individual fulfilment, responsibility for themselves and the community. Students start a business venture when they begin their studies, and in the course of their studies acquire the related knowledge and develop the competencies needed to run a business in an efficient manner. In addition to first-hand knowledge of the real-world market environment, students will learn how to collaborate in a team, learn to motivate and appreciate themselves and teammates, and to immerse themselves in life-long learning in their own business interests. The students' work is supervised by university professionals (team coaches) who were trained by the Finnish Team Mastery.

This modern teaching methodology is accepted in the field of international business education: Spain, France, Netherlands, England have launched their own "Team Academy" training based on the Finnish model.



The first courses of the Institute for Innovation in Engineering and Business Development (MŰZLI) established in 2018, were launched in the second semester of the academic year 2018/19. The market-oriented, practice-oriented training brings excellence in domestic and international business to the students of engineering, economics, management and IT.

Corporate professionals with decades of managerial and extensive professional experience ensure that students enter the labour market so that their knowledge, skills and competencies beyond professional knowledge are reinforced, they are able to identify the challenges to be addressed in the new technological era, and are capable of exploring their inherent creativity. The courses are primarily aimed at developing an entrepreneurial mindset but also provide insights into useful experiences gained through personal careers across a range of topics (e.g. benefits of determination or taking risks, key elements of industrial success in the industry, etc.).

In order to coordinate innovation management activities and provide competitive up-to-date services, a decision was made in 2019 to further develop the innovation ecosystem by necessary institutional changes: in line with the University of Debrecen's comprehensive mission statement the Innovation Ecosystem Center (Center) as a service unit, incorporating the Research Exploitation and Technology Transfer Center was established. The Center aims at the effective discovery of ideas, promoting the further development of ideas, the (market) exploitation of research potential and more efficient contribution to the local economic development through cooperation with the business and government sector and promoting the development and implementation of innovative responses to environmental, socio-economic challenges at the local level (IÖK, 2019).

At this point, it is worthwhile to mention the financing aspects of developing an innovation ecosystem and providing services at the early-stage. In addition to government funding sources through tenders, the Innovation Fund of the University of Debrecen (IFUD) was created - which clearly shows the leadership's commitment to promoting innovation. The IFUD provides funding to develop the innovation system, to increase the efficiency and effectiveness of innovation and R&D activities, and to contribute to the development and market introduction of useful products and services, taking into account social and environmental impacts (DEINA, 2018).

In particular, IFUD may provide funding for:

- the exploitation of R&D results ("proof of concept" sub-program)
- programs for exploring student ideas, developing and developing entrepreneurial skills (student sub-program)
- the development of the innovation ecosystem and the provision of services, in particular for the basic operation of the Innovation Ecosystem Center and UD Ventures Ltd. (Innovation ecosystem sub-program)

The aim of the Center, in close cooperation with the relevant departments of the University of Debrecen, is to strengthen entrepreneurial spirit and initiatives, dedication to teamwork and the emergence of ideas, regardless of the uncertainty inherent in innovation. Innovation services, cooperations, collaborations and partnerships reduce the risks behind an innovative idea in the marketplace, and are intended to help idea creators overcome the challenges successfully and effectively or even in the case of market failure of a certain idea encourage to invest energies in a faithful restart of ideation.

The knowledge and competency map on the one hand reveals exploitable R&D results and on the other hand facilitates to channel researchers and research groups through their available scientific and technological knowledge into new research programs based on domestic or international, research or industrial collaborations. Mentoring of student and research teams, and at a later stage of university-affiliated start-ups, spin-offs and micro-businesses, is based on international best practice. The system may work with mentors volunteering (not generating income, providing only reimbursement of expenses) so that to avoid the conflict of interest and appearance of self-interest.

The Center places particular emphasis on increasing the entrepreneurial activity of students and young researchers and organizes events to promote innovation and entrepreneurship (e.g. conferences, business incubation clubs, pitch competitions). At the same time, the Center – in cooperation with the departments concerned – promotes cooperation between students and the business sector based on international best practice. At some events, student groups design solutions for real industry innovation challenges in a team (development team) supported by facilitators and academic researchers. The Center will start a close cooperation with the clusters operating with active participation and leadership of the University of Debrecen.

### **3. Clusters**

The universities play an important role in the knowledge-based economy: they generate knowledge through their leading-edge research activities and provide highly qualified labour. In the case these functions are integrally linked and when they are most effective, the university contributes strongly to regional economic growth and development. It is important to define the precise role they play. Besides being the sources for knowledge and talents, they can also draw the attention of investors and strategically important companies (Wolfe, 2015).

The University of Debrecen is a pioneer in cluster organization in Hungary and plays a key role in creating and operating clusters. The aim of the clusters is to make technology transfer activities more efficient and thus contribute to the economic development of the region.

Over the past decade, five accredited clusters have been organized around the University of Debrecen, two of which are internationally accredited. Areas of operation of the clusters, in line with the strategic areas designated by the University of Debrecen: pharmaceutical, thermal and tourism, food, sports, information technology, instrument development.

The following clusters are functioning in the neighbourhood of the University of Debrecen:

- Pharmapolis Debrecen Innovative Pharmaceutical Cluster
- Hungarian Sports and Lifestyle Development Cluster
- Northern Great Plain Thermal Cluster
- Pharmapolis Innovative Food Cluster
- Silicon Field Cluster

Through these clusters, the University cooperates closely with hundreds of market players who can serve as a platform for the practical training of students, and effectively serve the utilization of research results and the development of innovation processes in the region.

The uniquely progressive feature of the clusters around the University of Debrecen is that it has created a nation-wide network of capital-intensive medium and large-scale companies, innovative university spin-offs and start-ups, municipalities, financial institutions, chambers. The clusters support the university industrial development efforts of the University.

#### **4. The Incubation Center**

Incubators are growing worldwide having similar infrastructure and graduation policies, while differing in their selection strategies, business support services and mediation offering (Bergek, A.-Norrman, C. (2008), Hausberg, J.P. – Korreck, S. (2018)).

Depending on operational frameworks, industry relations and experience in innovation management, European higher education institutions will pursue different strategies and provide different services as third mission activities are concerned.

The erection of the Incubation Center is another milestone in the innovation ecosystem development of the University of Debrecen, bringing a new approach to reinforce and extend innovation activities, join the international competition and cooperation between universities and to address local and regional market need more efficiently. The Incubation Center provides a comfortable, modern and healthy site, environment and community culture for the collaboration of educational and research institutions and businesses that attracts investment in research and thus contributes to economic growth.

The objective to be achieved through the establishment of the Incubation Center – in line with the university's innovation and business objectives – is to provide the appropriate site

to carry out incubation, acceleration, business development and related mentoring and advisory activities and project management tasks. The services of the co-working space will primarily be available for the researchers and students of the University of Debrecen.

The Incubation Center provides a venue for trainings and other advisory services offered by the Innovation Ecosystem Center that are designed and differentiated to suit the business, strategic, organizational or personal development needs and objectives of innovative teams.

- Within the framework of the *Action Learning Group*, advisory services, such as facilitation, peer mentoring, performance and process management, exchange of professional experience will be provided, and a focus would be on development of collaboration and knowledge sharing. The following skills and competences will be developed during the training: goal setting, focus, change management, decision making, presentation, feedback, knowledge-mobilising interviewing and summation techniques, constructive confrontation, performance-enhancing reflection at the individual level or within a group, self-reflection - self-awareness, problem-solving potential and innovation.

- *Business coaching* focuses on developing entrepreneurial skills, innovation and motivation through adequate process management models to achieve higher performance or profitability, and consulting to determine real, achievable and measurable business goals with respect to external and internal available and the deficiency of specific resources and preparation of strategic and implementation plans. Commitment, motivation and entrepreneurial mindset are the added value of the development process.

The process of facilitation and development takes place in a cyclical structure: consultation - implementation – monitoring, feedback, refinement - learning (Kolb, 1984).

- *Leadership mentoring*, trainings are available as a service to increase efficiency and motivation. The intervention process supports the development of professional identity and the effectiveness of professional role and responsibility, contributes to increased motivation, and promotes talent development and retention. The training covers the areas of delegation and empowerment, decision-making techniques, assertive communication - proactive modes of operation, resource management, problem solving and creativity development, change management, performance management, project management.

- In *pitch training*, students and researchers learn pitching through practice-oriented simulation modules, psychological, communication and presentation exercises. As a result of the activity, participants will be able to communicate effectively with investors and the likelihood of success will increase resulting in higher investments for faster growth.

The spaces created within the Incubation Center provide opportunities for team development and interaction between teams.

- In innovation open-spaces (co-working office), individuals and teams with an innovation idea can do office work on a hot-desk basis.
- Incubation teams can work in community-based hack-space to develop board models, prototype space, and equipment accessories (from simple machines to 3D printers).
- Incubation facilities (small and medium-sized offices) for groups, meeting room

In line with the University of Debrecen's goals to creating a broad network of innovation-related cooperations based on mutual benefit, the Incubation Center will greatly contribute to the development and strengthening of further economically beneficial links between the University of Debrecen and other economic actors. Service labs and R&D companies hosted at the first level of the Incubation Center, through their market-based services, R&D activities, and their role in student training, help to strengthen relationships and increase economic embeddedness.

## References

- Barakonyi Károly (2014). *Felsőoktatásunk 25 éve (eredmények – kudarcok)*. Felsőoktatási MŰHELY 2007-2014, 2014/II. szám - A rendszerváltó magyar felsőoktatás
- Bergek, A. - Norrman, C. (2008). *Incubator best practice: A framework*. *Technovation*, 28(1–2), 20–28.
- Deés, Sz. (2011). *Egyetemi tudománymarketing a harmadik generációs egyetem szemlélete és kommunikációja*. Doktori Értekezés, Pécsi Egyetem
- Hausberg, J.P. – Korreck, S. (2018). *Business incubators and accelerators: a co-citation analysis-based, systematic literature review*. *The Journal of Technology Transfer* pp 1-26
- Kolb, D. A. (1984). *Experiential learning: Experience as the source of learning and development* (Vol. 1). Englewood Cliffs, NJ: Prentice-Hall.
- Wolfe, D. A. (2015). *The Role of Universities in Regional Development and Cluster Formation*. In Glen Alan Jones, Patricia L. McCarney & Michael L. Skolnik (eds.), *Creating Knowledge. Strengthening Nations: The Changing Role of Higher Education*. University of Toronto Press. pp. 167--94 (2005)

## University internal documents:

- POC (2018). *Proof of Concept Program*, <https://unideb.hu/hu/pocprogram>
- DEINA (2018). *Debreceni Egyetem Innovációs Alap felhasználási és végrehajtási koncepció*
- IÖK (2019). *Debreceni Egyetem Innovációs Ökoszisztéma Központ szakmai koncepció*

## Strategy documents:

- Stratégia (2016). [Fokozatváltás a felsőoktatásban, A teljesítményelvű felsőoktatás fejlesztésének irányvonalai. A Kormány 1785/2016. \(XII. 16.\) Korm. határozata a „Fokozatváltás a felsőoktatásban középtávú szakpolitikai stratégia 2016” elfogadásáról](#)
- Stratégia (2017). [Fokozatváltás a felsőoktatásban középtávú szakpolitikai stratégia 2016-2020 évekre vonatkozó cselekvési tervéről. A Kormány 1359/2017. \(VI. 12.\) Korm. határozata](#)
- Magyar Közlöny (2013). [Befektetés a jövőbe, Nemzeti Kutatás-fejlesztési és Innovációs Stratégia \(2013-2020\), \(Stratégia \(2013\)\), A Kormány 1414/2013. \(VII. 4.\) Korm. Határozata a Nemzeti Kutatás-fejlesztési és Innovációs Stratégia \(2013–2020\) elfogadásáról](#)

## Measurement of the black globe temperature to estimate the MRT and WBGT indices using a smaller diameter globe than a standardized one: Experimental analysis

Carlos Vargas-Salgado<sup>a</sup>, Cristian Chiñas-Palacios<sup>b</sup>, Jesús Aguila-León<sup>c</sup>, David Alfonso-Solar<sup>d</sup>

<sup>a</sup>Department of Electrical Engineering, Universitat Politècnica de València, Spain.  
[carvarsa@upvnet.upv.es](mailto:carvarsa@upvnet.upv.es)

<sup>b,c</sup>Department of Water and Energy Studies, Universidad de Guadalajara, Mexico,  
[jesus.aguila@academicos.udg.mx](mailto:jesus.aguila@academicos.udg.mx), [daniel.chinas@academicos.udg.mx](mailto:daniel.chinas@academicos.udg.mx).

<sup>d</sup>Universitat Politècnica de València, Department of Applied Thermodynamics. Valencia (Spain).  
[daalso@iic.upv.es](mailto:daalso@iic.upv.es)

---

### **Abstract**

*Heat stress can affect negatively human performance, behavior and even health, therefore, mean radiant temperature (MRT) and wet-bulb globe temperature (WBGT) measurement and monitoring should be obtained for any environment in which people are constantly exposed. The aim of this work is to compare the globe thermometer temperature ( $t_g$ ), used for calculating both MTR and WBGT, using a smaller globe compared to a standardized diameter. For such purpose, a prototype has been designed. The device consists of an Arduino MEGA board, three temperature sensors, two black globes (Copper globe, matt black painted) and an anemometer. As an effort to use a device with a globe easier to handle in a real measuring device, a 9 cm diameter globe has been used which has a smaller diameter than a standardized one (15 cm); the third temperature sensor is used to measure the air temperature. MRT monitoring tests were carried out using the proposed prototype, collected data were compared between the smaller and the standardized diameter globes measurements according to UNE EN ISO 7723 and NTP 322 recommendations. Results of this work show that it is possible to use a smaller diameter globe in a heat stress monitor, with an acceptable margin of error compared to a standardized size globe.*

**Keywords:** Heat stress monitor; Globe temperature; MRT; Arduino.

---

## 1. Introduction

Contact to heat stress environments can produce health problems (Deschenes, 2014; Enander & Hygge, 1990; Fishman, Carrillo, & Russ, 2019; Gasparrini et al., 2017) and many times a heat stress index monitor cannot be representative (Maurya, Haque, Kumar, & Diwakar, 2019). To regulate human safety and health in working environments, UNE EN ISO 7726 regulations and NTP 322 propose a standardized method for heat stress index measurement such as MRT and WBGT, using the globe thermometer temperature.

If an MRT or WBGT monitor is designed and built according to UNE EN ISO 7726 and NPT 322 specifications, using a 15 centimeters temperature globe, it will be difficult to handle, prone to breakage and heavier. The objective of this work is to compare the globe thermometer temperature ( $t_g$ ), used for calculating both MTR and WBGT, using a smaller globe compared to a standardized diameter globe.

## 2. Methodology

In order to compare the temperature thermometer globe sensor used for calculating both MTR and WBGT, a low-cost heat stress monitor index have been designed and built. The device consists of an Arduino MEGA board, four temperature sensors (one DTH22 and three DS1802), two black globes (Copper globe, matt black painted), a relative humidity sensor (DHT22) and a cups anemometer. One globe is 9 cm diameter which has a smaller diameter than the standardized globe (15 cm), another temperature sensor is used to measure air temperature.

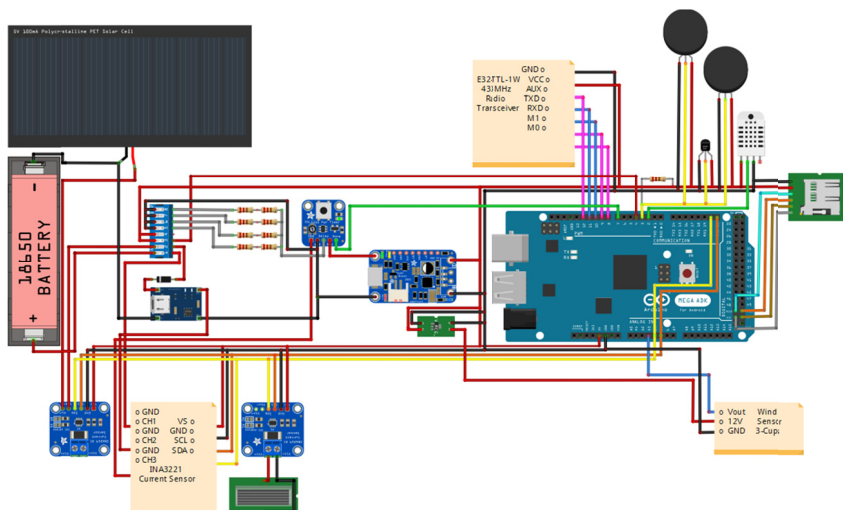

Figure 1. Proposed WBGT monitor prototype general scheme



As an effort of developing a cheap heat stress monitor, Figure 1 shows the general scheme of the prototypes. Both prototypes (9 and 15 cm diameter globe) were installed at the Polytechnic University of Valencia, to measuring continuously from February 2 to June 05, 2019, Figure 2 shows photographs of the deployed prototypes.



Figure 2. Proposed WBGT monitor prototype implementation

To obtain the WBGT index there are two possible situations, index estimation for indoor or for outdoor environments (Mendaza, 1993; NTP 322, 1999). According to NTP 322, WBGT index calculation for indoor (or outdoor without solar irradiance) and outdoor (with solar irradiance) environments is carried out by Equation 1 and Equation 2.

$$WBGT_{indoor} = 0.7t_{nwb} + 0.3t_g \quad \text{Equation 1}$$

$$WBGT_{outdoor} = 0.7t_{nwb} + 0.2t_g + 0.1t_a \quad \text{Equation 2}$$

Where,  $t_{nwb}$  is the natural wet-bulb temperature,  $t_g$  is the globe temperature and  $t_a$  is the dry air temperature.  $t_{nwb}$  is measured by a thermometer with its bulb covered with a wetted cotton, without shields for avoiding wind or radiation and under natural ventilation conditions and can be calculated using the Equation 3 (Hunter and Minyard 1999).

$$t_{nwb} = t_w + 0.0021S - 0.42v_w + 1.93 \quad \text{Equation 3}$$

Where,  $t_w$  is the psychrometric temperature of wet bulb,  $S$  is solar irradiation and  $v_w$  the wind velocity.  $t_w$  can be calculated using air by means of Equation 4, using air

temperature ( $t_a$ ) and relative humidity (RH%) measurements at standard sea level, as propose to (Stull, 2011).

$$t_w = t_a \tan^{-1} \left[ 0.151977(RH\% + 8.131659)^{1/2} \right] + \tan^{-1}(t_a + RH\%) - \tan^{-1}(RH\% - 1.676331) + 0.00391838(RH\%)^{3/2} \tan^{-1}(0.023101RH\%) - 4.686035 \quad \text{Equation 5}$$

Mean radiant temperature (MRT)  $\bar{t}_r$  is calculated according to (UNE ISO 7726, 2002) using Equations 6 to 9. Equations 6 is used for forced convection, and Equation 7 for natural convection when globe diameter is less than 15 cm. Equations 8 is used for forced convection, and Equation 9 for natural convection when globe diameter is equal to 15cm.  $\bar{t}_r$  depend on the globe temperature  $t_g$ , the thermal emissivity of the balloon  $\varepsilon_g$ , the diameter of the balloon  $D$  and the air temperature  $t_a$ .

$$\bar{t}_r = \left[ (t_g + 273)^4 + \frac{1.1 \times 10^8 (w_{speed})^{0.6}}{\varepsilon_g D^{0.4}} (t_g - t_a) \right]^{1/4} - 273 \quad \text{Equation 6}$$

$$\bar{t}_r = \left[ (t_g + 273)^4 + \frac{0.25 \times 10^8}{\varepsilon_g} \left( \frac{|t_g - t_a|}{D} \right)^{1/4} (t_g - t_a) \right]^{1/4} - 273 \quad \text{Equation 7}$$

$$\bar{t}_r = \left[ (t_g + 273)^4 + 2.5 \times 10^8 x (w_{speed})^{0.6} (t_g - t_a) \right]^{1/4} - 273 \quad \text{Equation 8}$$

$$\bar{t}_r = \left[ (t_g + 273)^4 + 0.4 \times 10^8 x |t_g - t_a|^{1/4} x (t_g - t_a) \right]^{1/4} - 273 \quad \text{Equation 9}$$

The choice between natural or forced convection equations depends on the thermal transfer coefficient ( $h_{cg}$ ) value. Using Equation 10 and 11 respectively,  $h_{cg}$  has been calculated for both forced and natural convection. If the thermal transfer coefficient for forced convection is greater than that natural convection, then forced convection equation for MRT should be used, and vice versa.

$$h_{cg} = 6.3 \left( \frac{w_{speed}^{0.6}}{D^{0.4}} \right) \quad \text{Equation 10}$$

$$h_{cg} = 1.4 \left( \frac{\Delta T}{D} \right)^{1/4} \quad \text{Equation 11}$$

### 3. Results

Figure 3a shows a scatter plot comparing the globe temperature measurements obtained between the 9cm and 15cm globes. A calibration curve, shown in Equation 11, was obtained by means of the linear regression (Figure 3a). The results of the 9cm measurements values correction are shown in Figure 3b, where  $t_{g,15cm}$ ,  $t_{g,9cm}$  and  $t_{g,9cm\_corrected}$  are compared in a typical day.

$$t_{g,9cm\_calibrated} = 0.9417 t_{g,9cm} + 0.5088 \text{ Equation 11}$$

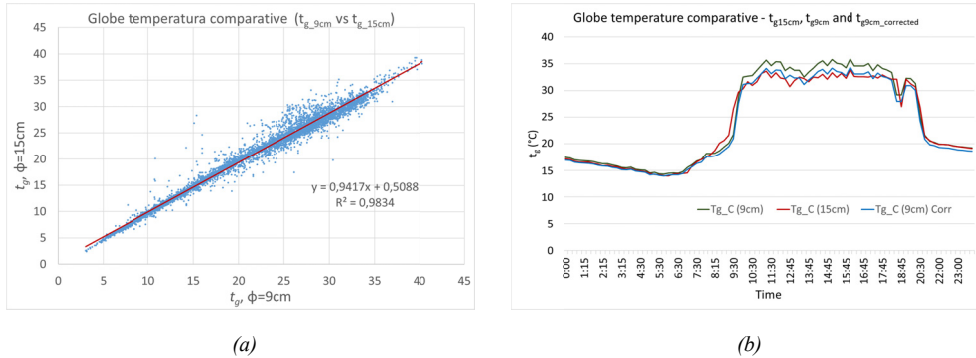

Figure 3. (a) Scatter graph between 9cm prototype measurements and standardized device and (b), curves obtained for a normal day using calibrated measurements.

Figure 4 shows the scatter plot and measurement curves for the MRT. The dispersion between MRT measurements is greater compared to globe temperature measurements. Equation 12 shows the calibration curve obtained by linear regression for measurements made using the 9 cm globe device.

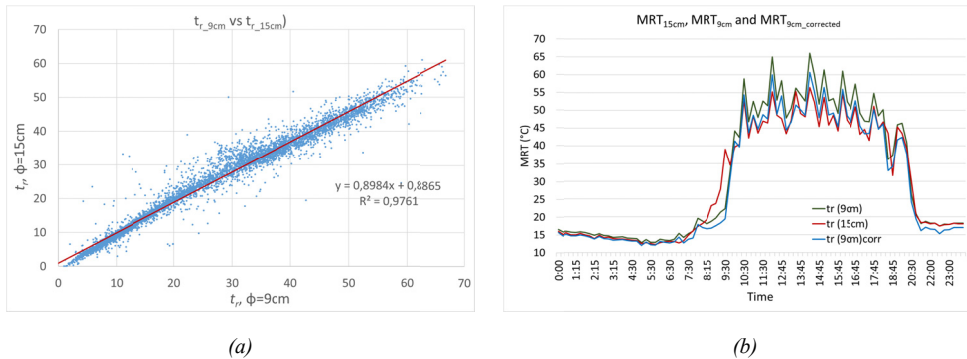

Figure 4. (a) Scatter graph between 9cm prototype measurements and standardized device and (b), curves obtained for a normal day using calibrated measurements for MRT.

$$\bar{t}_{r,9cm\_calibrated} = 0.8984 \bar{t}_{r,9cm} + 0.8865 \text{ Equation 12}$$

Similarly, Figure 5 shows both the scatter plot and the curves obtained for WBGT estimates and Equation 13 shows the calibration curve obtained. It is remarkable how WBGT measurements have the lowest degree of dispersion, compared to globe temperature and MRT measurements.

Measurement of the black globe temperature to estimate the MRT index using a smaller diameter globe than a standardized one: experimental analysis

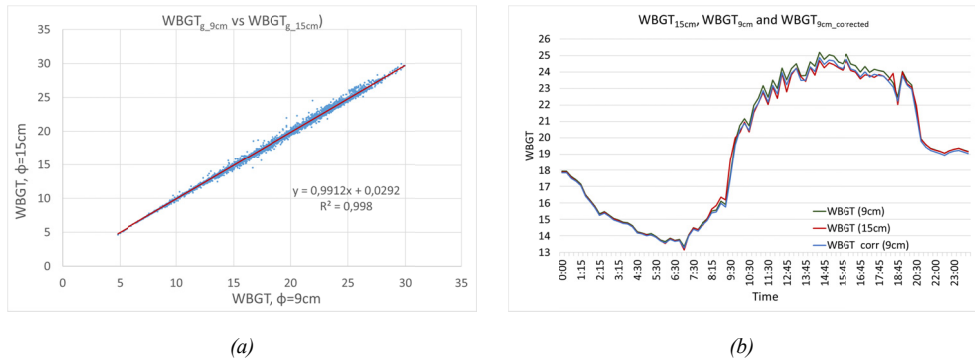

Figure 5. (a) WBGT measurements scatter plot between 9cm and 15cm globes and (b) comparison of measurements curves between both devices.

$$WBGT_{outdoor,9cm,calibrated} = 0.9912 WBGT_{outdoor,9cm} + 0.0292 \quad \text{Equation 13}$$

Table 1 summarizes the RMSE for the WBGT, MRT and globe temperature, using as a reference the measurements made by the standardized 15 cm globe device.

**Table 1. Error analysis between calibrated proposed prototype and standardized heat stress monitor**

Measurement	RMSE	
	Not-calibrated	Calibrated
$t_g$	1.93	1.76
WBGT	0.39	0.35
Mean radiant temperature (MRT)	3.81	3.33

According to the summary shown in Table 1, without error correction, the RMSE of Globe Temperature, WBGT, and MRT was respectively 1.93, 0.39 and 3.81. After applying the error correction equation, RMSE was respectively 1.76, 0.35 and 3.33, which means an improvement in the error of 9%, 9%, and 13% respectively.

#### 4. Conclusion

When calibrating the 9 cm globe by means of equations obtained from linear regression, it is observed that improvements in measurements for Globe Temperature, WBGT, and MRT reach 17, 20% and 24 respectively. This demonstrates that obtaining linear regression calibration curves from measured data over nearly 5 months could be an effective mean of

obtaining accurate values for WBGT, MRT, and globe temperature measurements using a 9cm globe prototype.

## Acknowledgements

This work was supported by the European Commission through GROW GREEN project (Agreement number: 730283 — GROW GREEN — H2020-SCC-2016-2017/H2020-SCC-NBS-2stage-2016. <http://growgreenproject.eu/>)

## References

- Deschenes, O. (2014). Temperature, human health, and adaptation: A review of the empirical literature. *Energy Economics*, 46, 606–619. <https://doi.org/10.1016/j.eneco.2013.10.013>
- Enander, A. E., & Hygge, S. (1990). Thermal stress and human performance. *Scandinavian Journal of Work, Environment and Health*, 16(SUPPL. 1), 44–50. <https://doi.org/10.5271/sjweh.1823>
- Fishman, R., Carrillo, P., & Russ, J. (2019). Long-term impacts of exposure to high temperatures on human capital and economic productivity. *Journal of Environmental Economics and Management*, 93, 221–238. <https://doi.org/10.1016/j.jeem.2018.10.001>
- Gasparri, A., Guo, Y., Sera, F., Vicedo-Cabrera, A. M., Huber, V., Tong, S., ... Armstrong, B. (2017). Projections of temperature-related excess mortality under climate change scenarios. *The Lancet Planetary Health*, 1(9), e360–e367. [https://doi.org/10.1016/S2542-5196\(17\)30156-0](https://doi.org/10.1016/S2542-5196(17)30156-0)
- Hunter, Charles H., Minyard, C. Olivia (1999) ESTIMATING WET BULB GLOBE TEMPERATURE USING STANDARD METEOROLOGICAL MEASUREMENTS. Westinghouse Savannah River Company, Aiken, South Carolina
- Maurya, P. K., Haque, N., Kumar, R., & Diwakar, R. (2019). SELECTING A SUITABLE HEAT STRESS INDEX TO PROTECT CATTLE AND, (March), 18–21.
- Mendoza, P. (1993). NTP 322: Valoración del riesgo de estrés térmico por índice WBGT. *Instituto Nacional de Seguridad e Higiene En El Trabajo*, (1), 1–6. Retrieved from [http://www.insht.es/InshtWeb/Contenidos/Documentacion/FichasTecnicas/NTP/Ficheros/301a400/ntp\\_322.pdf](http://www.insht.es/InshtWeb/Contenidos/Documentacion/FichasTecnicas/NTP/Ficheros/301a400/ntp_322.pdf)
- NTP 322: Valoración del riesgo de estrés térmico: índice WBGT, Ministerio de trabajo y asuntos sociales de España (1999)
- UNE ISO 7726, U. I. (2002). Norma española UNE ISO 7726.

## UNI-HERITAGE. European Postwar Universities Heritage: A Network for Open Regeneration

Débora Domingo Calabuig<sup>1</sup>, Laura Lizondo Sevilla<sup>1</sup>

<sup>1</sup>Department of Architectural Projects, Universitat Politècnica de València, Spain.

---

### **Abstract**

*This research project aims at the regeneration of European universities created in the 60s and 70s through a systematic, circular, open and integrated process of their cultural heritage. At present, these campuses represent both a tangible and intangible heritage (architecture, urban planning, landscape... but also pedagogy, specialization areas, educational policies) whose adaptation to contemporaneity involves issues related to environmental sustainability, to the institution organizational capacities, and to its social implication.*

*Specifically, this proposal focuses on actions that would offer strategies such as the renewal of infrastructures and services and the adaptive reuse of the built heritage (space recycling, sustainability), the updating of the physical teaching spaces to the new teaching methodologies (European Higher Education Area), and the campus social consideration as a comfortable, conflict-safe and cultural-integrated area.*

*Beyond the simple conservation, restoration and physical rehabilitation of a set of buildings and a university fabric, this project has the added value of an integrated or interdisciplinary action model that seeks four aspects of innovation: the organizational, the formative, the technological and social. This research proposes to ensure a longer life cycle for the heritage through its participation as a resource in the dynamics of regeneration of the universities.*

**Keywords:** *University campuses; European cultural heritage; Open regeneration; Adaptive reuse; Sustainable development.*

---

## 1. Introduction

This paper presents a research proposal focused on the scope of the regeneration of university cultural heritage through innovative actions. The proposal makes the most of opportunities offered by the program Horizon Europe, pillar III - Social Challenges; the sections SC-5: 'Climate action, environment, resource efficiency and raw materials' and SC-6 'Europe in a changing world - Inclusive, innovative and reflective societies' being the focus. Funded projects from previous calls concentrate on historic and cultural heritage in the urban context (Esposito De Vita *et al.*, 2018; ROCK Project H2020, 2017); also earlier studies address the universities from a social perspective (van de Laarse, 2017; Benneworth, 2014). However, the specificity of this project lies in considering university heritage as a European asset of common origin and to aspire to its regeneration through actions that will produce innovations integrated in the social, technological, institutional and educational fields.

## 2. History and current state

In years following the Second World War, higher education went through a serious evolution that developed into scaling transformations in institutional and social spheres. There were three main causes: population rise (the legal age of the baby boom generation), the specialization of knowledge that increased the offer of educational degrees, and the social and political awareness of a higher education for all. Each European country had their own difficulties, but in all educational reforms, pathways leading to the Welfare state were a priority. This meant the beginning of an in-depth social and pedagogical debate in which architects, city planners and landscape architects would take part (Coulson, Roberts and Taylor 2015).

Half a century later, the situation is far from what is once was. 'If the education system is the expression of the nation, the university system can perhaps be seen as an expression of the age', states Walker (2018). She also maintains that universities continue to be a public asset where the progress of knowledge is produced but also, 'Higher education is being profoundly reshaped by its marketization, with league tables, branding, discourses of 'excellence' and competition for students framing such moves'.

From that postwar "utopic" vision -in terms of progress, confidence and growth - to the current neoliberal situation and conservative changes, European universities that emerged in the 60's and 70's have built a huge and rich cultural heritage in distinctive features, but with shared roots and common decisions. The European Union was built on the willingness of political and economic stability and the climate of collaboration favored future deals that led their member states towards a common market. The result of more than half a century of progress is a vast cultural panorama whose study from the view of higher education is more significant if we pay attention to the value of education in building a society.

If cultural heritage is all the tangible and intangible demonstrative materials of a society, the university cultural heritage is comprised of an entire legacy stemming from institutions dedicated to higher education. Within the sphere of non-material characteristics the educational policies are found (the profile and the specialization of areas of knowledge, the degrees, study plans, teaching, university management, the sociologic considerations and consequences...); among the “physical artifacts” that make up the university heritage, there is a wide variety of buildings, public spaces, works of art, natural and urban surroundings, infrastructures and other aspects derived from the territorial sphere.

The current state of this theme is proof of consistent research on all the factors that make up university cultural heritage, but they are mainly approximations that deal with the different issues separately, without even contributing to a possible mainstreaming between tangible and intangible heritage. In addition, the approach to study is carried out from a historical point of view, conservation and management, but works that refer to a more active role of heritage – as suggested in the European calling for R+D+I are scarce.

### **3. Hypothesis and objectives**

The objective of this proposal is to develop an innovative, collaborative and circular systematic approach for the regeneration and adaptive reuse of the university cultural heritage that originated in the 60s and 70s of the 20th century. Starting from a data collection and sharing the processes openly, a monitoring of the different experiences is sought such a way that that the collective cultural awareness is activated and the innovations and adaptations to contemporary needs are optimized.

It should be considered that the work material includes both tangible and intangible heritage, and the interest of this project is focused on the actions where both are combined in generating new knowledge. The updating and the regeneration of the universities cannot be overlooked by searching for isolated solutions according to the different fields of action. Currently, the university policies do not contemplate physical and spatial adaptation to particular learning strategies of implantation nor of spatial adjustment to teaching, as the West German government did during the 60s and 70s. In addition, many current universities have become isolated ghettos with respect to their urban and peri-urban surroundings, with the consequent lack of integration in the social fabric and the growing problem of security in their facilities: a situation completely opposite to the purposes of the new French universities after the events of May 1968. A collaborative platform seems appropriate now, which allows the awareness of a European cultural heritage -which has traveled a historical path in parallel-, taking into account its more complete and interdisciplinary landscape.



The research hypothesis assumes that by implementing an index of successful regeneration initiatives promoted by any interested party, one can replicate the approach and test the models that address the specific needs of postwar university campuses.

Thus, the project is based on establishing a network of contemporary universities, as well as participatory and interested bodies (local or regional governments, private companies, research institutes, professional institutions related to the university world, cultural associations...), forming a consortium with common interests in different European countries. The actions involve research and innovation, both by collecting past experiences (to generate a database), and a commitment to collaborate in the new actions. A work platform allows new ways of collecting and exchanging data to facilitate networks and synergies. In turn, this monitoring tool enables the initiatives to be eventually classified according to their success ('role model') and can be transferred as 'suitable for replication', adopting a multidisciplinary tutoring process and defining common protocols and guidelines for implementation ('repeater role').

The added value is the combination of action models, work plans, financing mechanisms, etc. associated with improvements, adaptations and regenerations of the university cultural heritage. Beyond the simple conservation, restoration and physical rehabilitation of a set of buildings and a university fabric, with this project it is possible to produce results related to four areas of innovation:

1. Organizational innovation of the campuses, which deals with different scales of relationship between the entities involved.
2. Innovation in training, which ranges from spaces for education to strategies for the implementation of educational policies.
3. Innovation in technology, which aims to optimize the built and open spaces of the campus in order to improve its indicators.
4. Social innovation, which includes community considerations, the approach between universities and society, and participatory processes in the face of decision-making.

The proposal incorporates a preliminary list of specific objectives that are linked to one or several sectors of innovation (Table 1).

**Table 1. Specific objectives of the project and its link to each of the innovation sectors**

<b>Specific objective</b>	<b>Innovation areas</b>
1_ Recognizing the key issues of the potential of university cultural heritage	I. Organizational
2_ Defining the process that allows knowledge and mapping university cultural heritage in an integrated way	I. Training, technology and social
3_ Designing regeneration measures that include new technologies, new teaching methods, new services and products to create new ways to access university cultural heritage	I. Training, technology and social
4_ Generating an effective framework for follow up and evaluation	I. Technology
5_ Generation and circular an inclusive chain to connect actors and activities involved with university cultural heritage.	I. Social
6_ Improving the cooperation and capability to create networks of all the institutions in the consortium	I. Organizational

Source: Authors (2018).

#### **4. Program and management**

The project’s management is based on the collaboration of European universities considering them from a cultural diversity perspective and with different interests regarding their regeneration. In this way, and for any specific action aimed at a transformation, some universities with a high level of development play the 'model' role, perceiving themselves experts, while others with similar needs, but not experienced, play the 'repeater' role. Not all actors have the same label in all actions: universities are considered in their 'model role' in some issues, but in their 'repeater role' in others (Figure 1).

The work strategy is based on a cycle of four fundamental phases. In phase 1, a knowledge archive is created, where the successful experiences as well as the specific heritage inventories of the universities are carried out. In phase 2, the roles are linked and the information is transmitted, assuming the tutoring process. In phase 3, the action is carried out. In phase 4, the result is evaluated and improved. The phases follow a loop structure that

consecutively adds models of successful initiatives to the knowledge archives, with continuous feedback with respect to their implementation and evaluation.

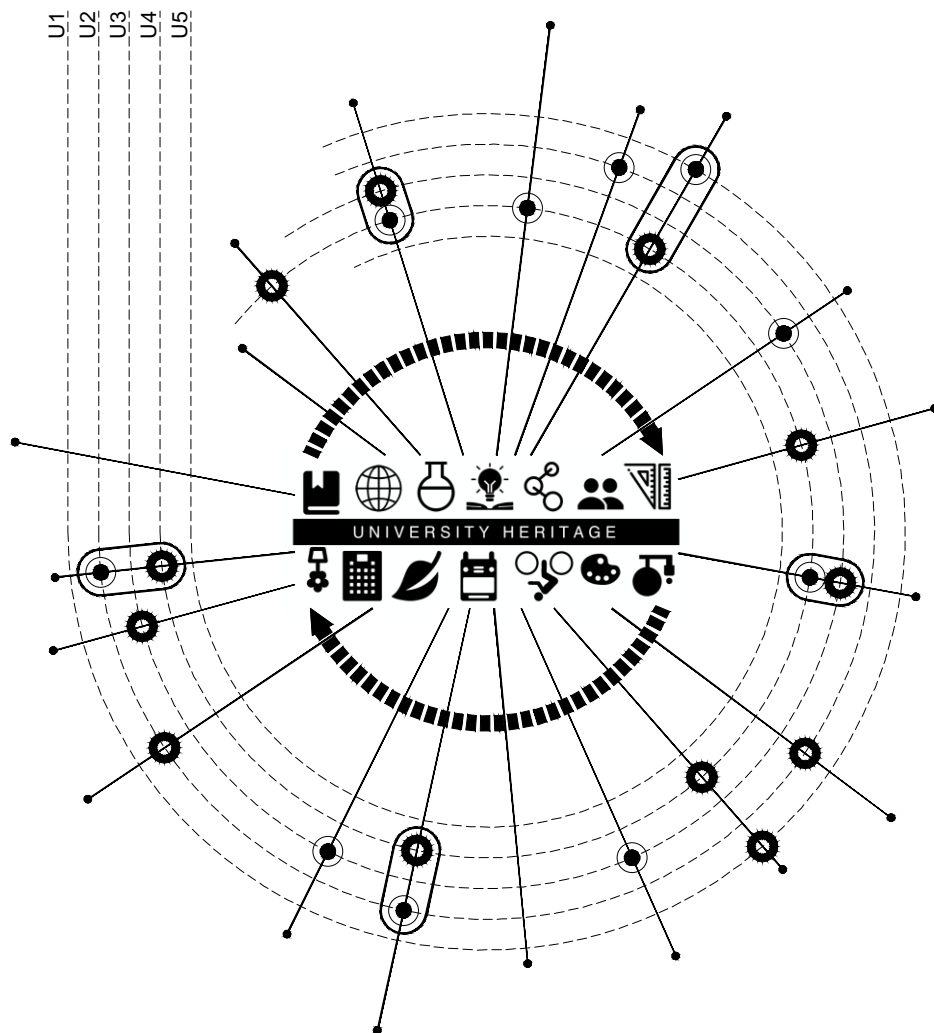

Figure 1. UNI-HERITAGE. Diagram of actions (convergent lines) for achieving specific objectives. Each university in the network (U1, U2, U3...) positioned according to role (full point/hollow point) in its actions. When role model and repeater role coincide, the development of the mentoring action takes place.

Source: Authors (2018).

## 5. Impact and results

The expected impacts are primarily related to the achievement of effective and shared policies that will be able to accelerate the regeneration based on university heritage. Consequently, the accessibility and social cohesion will be improved, the participation in the decision-making process will be increased and business opportunities will be fostered.

This impact is in line with the interests of the European calls and falls within the four domains of innovation described in the general and specific objectives mentioned above. The effects of the project mean a temporary double scale: on the one hand, the impact takes place within the same period of development of the work; On the other, collaboration processes generate synergies whose consequences would be made evident a later stage.

Thus, the results of the project can be observed under three perspectives:

A first block of results transfer is the one related to the work approach of an innovative nature and with a systematic, circular, open and collaborative character.

Secondly, the results transfer related to the interactive work platform must be considered and once operational, it will allow a wide range of applications. It is not just an archive with databases, but rather a tool that can incorporate other existing software and contemplate new functionalities for university campuses as well as the integration of existing computer applications.

Finally, the results transfer of the actions or projects carried out through this proposal are fundamental since they facilitate the creation of innovations regarding their heritage consideration.

## References

- Benneworth, P. S. (2014). Measuring the societal impacts of universities' research into arts and the humanities (HERAVALUE). In P. Hunter (Ed.), *HERA joint research programme: outcomes and achievements* (pp. 73-76). HERA, Humanities in the European Research Area. Retrieved from <https://research.utwente.nl/en/publications/measuring-the-societal-impacts-of-universities-research-into-arts-2>
- Gabriella Esposito De Vita, Antonia Gravagnuolo, & Stefania Ragozino. (2018). Circular models for the city's complexity. <https://doi.org/10.5281/zenodo.3061221>
- Coulson, J., Roberts, P., & Taylor, I. (2015). *University Planning and Architecture: The Search of Perfection*. Oxon: Routledge.
- ROCK: Regeneration and Optimisation of Cultural heritage in creative and Knowledge cities. (2017) Project ID: 730280. Funding scheme: IA - Innovation action. Retrieve from <https://cordis.europa.eu/project/rcn/210174/factsheet/en>

van der Laarse, R. (2017). Accessing Campscapes (iC-ACCESS): Inclusive Strategies for European Conflicted Pasts. Online publication or Website, Amsterdam: UvA (iC-ACCESS). Retrieved from <http://www.campscapes.org/>

Walker, P. (2018). Why Universities Matter. *New Vistas*, 4(1), 4-11.

## Measurement of the Teamwork and Networking Competencies in Innovative Contexts

Juan Antonio Marín García<sup>1</sup>, Maribel Martínez-Villaescusa<sup>1</sup>, Lourdes Aznar Mas<sup>1</sup>

<sup>1</sup>Universitat Politècnica de Valencia, Spain.

---

### **Abstract**

*The aim of our research is to develop a questionnaire that allows a valid and reliable self-assessment of two soft competencies: Teamwork (TW) and Networking (NW), for professionals at organizations or job applicants.*

*In this paper, focus will be set on the filtering of a bank of possible items, and the confirmation that the items finally selected:*

- a) Represent one or several conceptual dimensions within TW or NW*
- b) Show an agreement between independent evaluators to analyze the overlap between items and dimensions: in our case, to be able to classify the items into their adequate dimension*
- c) Check that the set of items selected in agreement among evaluators represents all the sub-dimensions of the construct to be assessed*

*We will use the bank of TW and NW items identified by previous research (itemsA) (Lukes & Stephan, 2017, Pérez Peñalver et al., 2018), which was classified and carried out within the European Project FINCODA (itemsB) (Marin-Garcia, 2018). With itemsA and B, we will try to sort out items into their corresponding categories.*

*To identify the items with the best content validity, we will use the raw agreement and Content Validity Ratio (CVR) measures (Lawshe, 1975, Tristan-Lopez, 2008), the intercoder agreement measures (Marin-Garcia et al., 2008a; Marin -Garcia et al., 2016b) and Krippendorff's Alpha (Friese, 2018; Krippendorff, 2018; Krippendorff et al., 2016).*

**Keywords:** *learning; soft-skills; teamwork; networking; measurement model.*

---

This paper has been submitted for publication in a scientific journal.

5th CARPE Conference  
HORIZON EUROPE AND BEYOND



UNIVERSITAT  
POLITÈCNICA  
DE VALÈNCIA

VALENCIA (Spain)

23-25<sup>TH</sup> OCTOBER 2019

HEALTH



UNIVERSITY of  
DEBRECEN



## Promoting health and well-being of entrepreneurs with health technology

Reetta Raitoharju<sup>1</sup>, Katja Heikkinen<sup>1</sup>

<sup>1</sup>Turku University of Applied Sciences, Finland

---

### **Abstract**

*In Finland the number of entrepreneurs over 55 years old has increased from 60.000 to 100.00 between 2000-2010. The growth has continued since that and now, there are 113.000 entrepreneurs in Finland who have reached the age of 55. Most of the companies in Finland are micro or SSM's and the responsibility of entrepreneurs' health and well-being is lies often on the shoulders of the entrepreneurs themselves. Supporting this group by giving them means more effectively to take action in preventing work- and age-related injuries and problems can help in prolonging careers.*

*Entrefox is a project funded by European Social Fund and it aims at promoting the health and well-being of entrepreneurs and future entrepreneurs over the age of 55 especially following the principles of active ageing and lifelong learning. Three groups of 10 entrepreneurs will be organized to create their own well-being plans and to give them means to follow the progress of their plan. Health technology will be used to help observing and motivating the process. Furthermore, students from different fields (physiotherapy, engineering and health promoting) will be included to support the entrepreneurs.*

**Keywords:** *entrepreneurs, health promotion, health technology*

---



## **1. Introduction**

Finnish economy is facing challenges caused by the ageing population and therefore, prolonging working careers and including all the citizens into the workforce is crucial. Entrefox is a project funded by European Union Social Fund that supports +55 year entrepreneurs in active ageing and life long learning. Entrepreneurs often retire older than people working on salary in average. Moreover, +55 year workforce often have a lot of knowhow, tacit knowledge and networks that are very valuable for the economy.

For most of the entrepreneurs, entrepreneurship is an intended and valued way of making a living. The amount of entrepreneurs that have ended up of being entrepreneurs only because of the circumstances is lower in Finland than in EU countries in general. However, the job satisfaction among the Finish entrepreneurs is lower than in EU in general. Especially grand this difference is between the Finnish and other Scandinavian entrepreneurs. (Tilastokeskus 2018.)

There are several definitions on well-being. With the well-being of the entrepreneurs we mean the experience of satisfaction of people's life. Actually, well-being should be considered an umbrella term that reflects multiple dimensions instead of capturing something unidimensional. (Wiklund et al. 2019.)

Almost one in five (18%) entrepreneurs often reported having difficulties working in 2017. A quarter (24%) of the entrepreneurs felt of neglect in the work – especially with the specialist experts in knowledge work. (Tilastokeskus 2018.)

One of the current megatrends of health care is that the treatment is transformed from mass-oriented care towards individual care. Technology offers us new ways to promote individual and self-care. Self-care services are a way to increase the well-being of Finns and to target healthcare more effectively. Finland already has electronic services for promoting well-being and monitoring health. A high percentage of Finns say that they like monitoring their own health and looking after themselves. (Sitra)

Technology can be used in several ways to support health and well-being activities. For instance different activity trackers and health apps is becoming increasingly popular. In many cases, older adults are the fastest growing computer and Internet user group in both personal and workplace contexts. (Wagner 2010) Overall, technology is an important tool in improving access to health care for older people and empowering them to take an active role in health activities. (Czaja 2013)

## **2. Entrefox project**

Entrefox will be implemented between 1.2.2019 – 31.12.2021 by Turku University of Applied Sciences, Finnish Institute of Occupational Health and University of Helsinki. The

Finnish ESF project is linked to Sweden's corresponding ESF project, "BSLF Sustainable Working Life - SWL", where the key themes are lifelong learning and active aging. Other international partner countries are Latvia and Lithuania.

In Entrefox, there are four different workshops that are aiming at supporting active ageing and life long learning of +55 year entrepreneurs. These workshops cover multiple issues such as digital capabilities or peer-support. In this paper we concentrate on describing one of the workshops that is particularly aiming at increasing the physical well-being and health at work.

In order for +55 year entrepreneurs to be able to work longer and cope with the demands of the changing working life, attention should be paid to foster their health and well-being. In scope should not only be those risks caused by work itself but also the changes brought by the age should be considered and prevented. Especially in small companies the entrepreneurs often are themselves responsible of their working conditions and well-being and support and tools to enhance that is the goal of the health and well-being workshops in Entrefox.

In health and well-being workshop, a tool will be created that helps +55 year entrepreneurs to take active role in developing their own well-being and coping with work. The tool is based on entrepreneurs' own goals and monitoring the progress. Special emphasis is paid on using health technology.

The project is carried out three workshops for the participants during the half-year. In the first workshop we will focus on defining the participants' own well-being goals. Thereafter, the participants will have the opportunity to participate in the physical fitness assessment and physical body measurement performed by the physiotherapist students and professionals (Liilab). Participants will have the opportunity to communicate with each other and with project staff through Skype.

Master students from health and-wellbeing will plan and organize the workshops.

### **3. Evaluation of the project**

For all the Entrefox project participants, there is a questionnaire form covering issues such as perceptions about own capabilities, perceptions about the future, and engagement to work. This questionnaire will be handed out both at the beginning of the workshops as well as at the end. The questionnaire is aimed at capturing possible change in satisfaction, capabilities and well-being during the Entrefox participation.

Besides that, participants will get questionnaire about their wishes and expectations in advance. During the workshops, participants are also asked to evaluate the usefulness of the workshops and the progress of well-being. These results are used to co-create better

workshops and tools for the +55 entrepreneurs. Results are also analysed to create the end-evaluation of the project.

#### **4. Conclusions and future research**

As an end-product of Entrefox, we wish to build a tool that can be used by the +55 year old entrepreneurs when developing their job satisfaction and well-being. However, this tool will only be based on the Finnish data and experiences and it would be most valuable to expand this work also internationally. Therefore, we are interested in expanding the project internationally in the future and are in search for partners to join us.

#### **References**

Czaja, S, Beach, S, Charness, N, Schulz, R, 2013, Older Adults and the Adoption of Healthcare Technology: Opportunities and Challenges, In Technologies for Active Ageing eds. Sixsmith, A and Gutman, G. Springer 2013.

LiiLab 2019. <http://www.turkuamk.fi/fi/tyoelamapalvelut/palvelut/liikunta-ja-toimintakykylaboratorio-liilab/>

Sitra. <https://www.sitra.fi/en/topics/self-care/#latest>

Tilastokeskus 2018. YRITTÄJÄT SUOMESSA 2018. Sutela H & Pärnänen A. Helsinki 2018.

[http://www.stat.fi/tup/julkaisut/tiedostot/julkaisuluettelo/ytym\\_201700\\_2018\\_21465\\_net.pdf](http://www.stat.fi/tup/julkaisut/tiedostot/julkaisuluettelo/ytym_201700_2018_21465_net.pdf)

Wagner, N, Hassainen, K, Head, M, 2010, Computer use by older adults: A multi-disciplinary review, Computers in Human Behavior 26(5), P 870-882

Wiklund, J, Nikolaev, B, Shir, N, Food, M-D Bradley, S. 2019.

Entrepreneurship and well-being: Past, present, and future. Journal of Business Venturing 34(4), 579-588. <https://doi.org/10.1016/j.jbusvent.2019.01.002>

## European Integrated Care Horizon 2020: increase societal participation; reduce care demands and costs

Roelof Ettema<sup>1</sup>, Goran Gumze<sup>2</sup>, Katje Heikkinen<sup>3</sup>, Kirsty Marshall<sup>4</sup>

<sup>1</sup>HU University of Applied Sciences Utrecht, The Netherlands, <sup>2</sup>Alma Mater Europaea-ECM, Slovenia, <sup>3</sup>Turku University of Applied Sciences, Finland, <sup>4</sup>University of Salford, United Kingdom.

---

### **Abstract**

*Care recipients in care and welfare are increasingly presenting themselves with complex needs. However, care and welfare are still mainly offered in a standardized, specialized and fragmented way. Support societal participation, quality of live and reduce care demand and costs in people with complex care demands, through integration of healthcare and welfare services.*

*By studying contexts and influencing mechanisms for favourable outcomes with regard to personalised integrated care will allow meeting the complex care demand of people. This will be enabled by focussed on societal participation in all integrated care best practices. Creating such best healthcare and welfare practices will be done in Slovenia, Poland, Austria, Norway, UK, Finland, The Netherlands: 3 integrated best care practices per involved country.*

*Studying desired behaviours of healthcare and welfare professionals, managers of healthcare and welfare organisations, members of involved funding organisations and national umbrella organisations for healthcare and welfare, regional policymakers, national policy makers and European policymakers. Integrated care starts with an extensive assessment with the care recipient. Then the required care and services is delivered to the person (fellow human) at home or as close as possible.*

**Keywords:** *Integrated Care; societal participation; quality of live; reduce care demands and costs; complex care demands.*

---

## **1. Background**

Care recipients in care and welfare are increasingly presenting themselves with complex needs (Huber et al., 2016). An answer to this is the integrated organization of care and welfare in a way that personalized care is the measure (Topol, 2016). The reality, however, is that care and welfare are still mainly offered in a standardized, specialized and fragmented way. This imbalance between the need for care and the supply of care not only leads to under-treatment and over-treatment and thus to less (experienced) quality, but also entails the risk of mis-treatment, which means that patient safety is at stake (Berwick, 2005). It also leads to a reduction in the functioning of citizens and unnecessary healthcare cost (Olsson et al, 2009)..

## **2. Integrated Care**

Integrated care is the by fellow human beings experienced smooth process of effective help, care and service provided by various disciplines in the zero line, the first line, the second line and the third line in healthcare and welfare, as close as possible (Ettema et al, 2018; Goodwin et al, 2015).

Integrated care starts with an extensive assessment with the care recipient. Then the required care and services in the zero line, the first line, the second line and / or the third line are coordinated between different care providers. The care is then delivered to the person (fellow human) at home or as close as possible (Bruce and Parry, 2015; Evers and Paulus, 2015; Lewis, 2015; Spicer, 2015; Cringles, 2002).

## **3. Aim**

Support societal participation, quality of live and reduce care demand and costs in people with complex care demands, through integration of healthcare and welfare services.

## **4. Methods (overview)**

1. Create best healthcare and welfare practices in Slovenia, Spain, Poland, Austria, Norway, UK, Finland, The Netherlands: 3 integrated best care practices per involved country
2. Get insight in working mechanisms of favourable outcomes (by studying the contexts, mechanisms and outcomes) to enable personalised integrated care for meeting the complex care demand of people focussed on societal participation in all integrated care best practices

3. Disclose program design features and requirements regarding finance, governance, accountability and management for European policymakers, national policy makers, regional policymakers, national umbrella organisations for healthcare and welfare, funding organisations, and managers of healthcare and welfare organisations
4. Identify needs of healthcare and welfare deliverers for creating and supporting dynamic partnerships for integrating these care services for meeting complex care demands in a personalised way for the client
5. Studying desired behaviours of healthcare and welfare professionals, managers of healthcare and welfare organisations, members of involved funding organisations and national umbrella organisations for healthcare and welfare, regional policymakers, national policy makers and European policymakers document.



## 5. Involved parties

Alma Mater Europaea Maribor Slovenia , University of Applied Sciences Valencia Spain, Jagiellonian University Krakow Poland, University Graz Austria, Kristiania University Oslo Norway, Salford University Manchester UK, University of Applied Sciences Turku Finland, University of Applied Sciences Utrecht The Netherlands (secretary), Rotterdam Stroke Service The Netherlands, Vilans National Centre of Expertise for Long-term Care The Netherlands, NIVEL Netherlands Institute for Health Services Research, International Foundation of Integrated Care IFIC.

## References

- Berwick DM. The John Eisenberg Lecture: Health Services Research as a Citizen in Improvement. *Health Serv Res.* 2005 Apr; 40(2): 317–336.
- Bruce D, Parry B. Integrated care: a Scottish perspective. *London J Prim Care (Abingdon).* 2015; 7(3): 44–48.
- Cringles MC. Developing an integrated care pathway to manage cancer pain across primary, secondary and tertiary care. *International Journal of Palliative Nursing.* 2002 May 8;247279.
- Ettema RGA, Eastwood JG, Schrijvers G. Towards Evidence Based Integrated Care. *International journal of integrated care* 2018;18(s2):293. DOI: 10.5334/ijic.s2293
- Evers SM, Paulus AT. Health economics and integrated care: a growing and challenging relationship. *Int J Integr Care.* 2015 Jun 17;15:e024.
- Goodwin N, Dixon A, Anderson G, Wodchis W. Providing integrated care for older people with complex needs: lessons from seven international case studies. King's Fund London; 2014.
- Huber M, van Vliet M, Giezenberg M, Winkens B, Heerkens Y, Dagnelie PC, Knottnerus JA. Towards a 'patient-centred' operationalisation of the new dynamic concept of health: a mixed methods study. *BMJ Open.* 2016 Jan 12;6(1):e010091. doi: 10.1136/bmjopen-2015-010091..
- Lewis M. Integrated care in Wales: a summary position. *London J Prim Care (Abingdon).* 2015; 7(3): 49–54.
- Olsson EL, Hansson E, Ekman I, Karlsson J. A cost-effectiveness study of a patient-centred integrated care pathway. 2009 65;1626–1635.
- Spicer J. Integrated care in the UK: variations on a theme? *London J Prim Care (Abingdon).* 2015; 7(3): 41–43.
- Topol E. (2016) *The Patient Will See You Now. The Future of Medicine Is in Your Hands.* New York: Basic Books.

## Research Centre for Healthy and Sustainable Living

Raymond Pieters<sup>1</sup>, Nienke Bleijenberg<sup>1</sup>, Katarina Jerkovic<sup>1</sup>, Cyrille Krul<sup>1</sup>, Cindy Veenhof<sup>1</sup>, Harriet Wittink<sup>1</sup>

<sup>1</sup>HU University of Applied Sciences Utrecht, The Netherlands.

---

### **Abstract**

*The Research Centre for Healthy and Sustainable Living of the University of Applied Sciences Utrecht aims to enable healthy urban living.*

*According to the latest concept, health entails the capacity to respond resiliently to stressors that disturb homeostasis. In addition, an individual's health benefits from the ability to self-manage and is determined by personalized conditions. One of the derived research challenges is to obtain know-how (biomarkers) and tools (e.g. point-of-care, wearables) to monitor an individual's health condition in daily life.*

*The well-known quotes "you are what you eat" and "sitting is the new smoking" indicate that condition of the oro-gastrointestinal tract and physical activity are pivotal to health. With this popular knowledge, we set out to identify biomarkers to monitor health benefits from nutrition and physical activity. Our first studies with human volunteers aimed at defining which physiological parameters were responsive to a defined stressor. We used exercise performed on a bicycle ergometer as a known stressor and aimed at defining the extent of exercise (defined by Wmax) needed to influence physiological relevant parameters. Young male volunteers executed different exercise protocols of different intensities, ranging from mild (1 h, 50% Wmax) to extensive (1h, 70% Wmax). We measured kinetic changes in blood of various physiological parameters. Changes in for instance blood leukocytes, and various intestinal parameters (e.g. intestinal Fatty Acid Binding Protein, iFABP) indicated that responses depend on the extent of physical activity. In addition, changes were influenced by an unhealthy condition, which was deprivation of water intake during exercise. Data indicates that responses to exercise can be induced by a milder exercise protocol, and that responses depend on health condition. This suggests that*



*the exercise model can also be used to test health in less fit individuals such as elderly or individuals with lower condition (e.g. chronic patients).*

*We are now interested to assess how responses to exercise differ by age, gender and life style. Our next research goals are therefore to: -evaluate the initial selection of biomarkers in specific patient-groups and; -how these biomarkers are influenced by the condition of the oro-gastrointestinal tract, e.g. via nutrition.*

**Keywords:** *bionmarkers; health; point of care; wearables*

---

This paper has been submitted for publication in a scientific journal.

## **European Integrated Care Horizon 2020: increase societal participation; reduce care demands and costs in Finnish context**

**Katja Heikkinen<sup>1</sup>, Mari Lahti<sup>1</sup>, Johanna Berg<sup>1</sup>, Arina Kiseleva<sup>1</sup>, Sini Eloranta<sup>1</sup>**

<sup>1</sup>Turku University of Applied Sciences, Finland

---

### ***Abstract***

*This project is part of larger European level integrated care project led by HU University of Applied Sciences. In Finland, the integration of social and health care services has taken center stage in both the policy and practice arenas. The needs of many client groups, e.g. mental health client or older people, are many and varied.*

*Poor mental health considerably impairs well-being of the population and has considerable economic consequences like absence from work, early retirement and productive losses. In this, professionals with different training backgrounds co-ordinate their expertise in providing care for their shared clients. It provides a safe nexus for the exchange of knowledge and opinions, as well as a framework for reaching a consensus about appropriate health care delivery for a particular client or client cohort. The client should have an immediate access to integrated care, with a focus on rehabilitation in patient's social roles.*

*The aim of this project is support societal participation, quality of life and reduce care demand and costs in social and health care client. There is a need to better understand different integrated care approaches for social and health care and guide future implementation of new integrated care models.*

**Keywords:** *Integrated Care; social and health care: mental health: Horizon 2020*

---

## **1. Introduction**

Care for people with long-term and complex care needs requires a great deal of coordination and collaboration. Without improved collaboration between social and healthcare professionals many people will use unnecessarily fragmented health care systems. In Finland as well as in many other countries, integrated care is seen as a possible solution to the growing demand for improved patient care in social and health care.

There is a health and social services reform in Finland. With the reform it will be reshape the structures and services in health and social care. With the reform will be objectively trying to reduce inequalities in health and wellbeing, improve the quality of services and the access to services – focus is in integrated care (Ministry of Social Affairs and Health).

Integration in care is the combination of processes and methods that facilitate integrated care and results directly benefits communities and patients or service users. (WHO, 2016). Challenge with the integrated care is that it cannot be concluded that one model best supports integrated care (WHO, 2016).

With this paper we represent the current situation of integrated care in Finland with the examples of mental care and older people services.

## **2. Integrated care**

Integrated care is an approach to tackle care fragmentations, particularly implemented to improve care outcomes and care experiences in all levels (Goodwin, 2015). The process of integrated care starts with a full patient assessment, followed by coordinated services between the three levels of care providers. The care is then delivered to the patient at home or as close as possible (Bruce & Parry, 2015; Evers & Paulus, 2015; Lewis, 2015; Spicer, 2015; Cringles, 2002).

The main characteristic of integrated care is complexity. A good understanding of the various dimension of integration is the first step towards integrated care (WHO, 2016).

### *Forms of integrated care*

Several taxonomies and conceptual frameworks have been developed to give a better understanding of integrated care. Typically, the taxonomies include type, level, process, breadth, and intensity of integration. Lewis et al. (2010) recognize four types of integration: organizational, clinical, service, and functional. Organizational integration can be defined as several organizations working together through a coordinated provider. Integration of care into a single and coherent process within/or across professions by using shared guidelines is clinical integration. Service integration is the integration of services on an organizational

level through teams of multi-disciplinary professionals. Functional integration refers to the integration of back-office and non-clinical support, for example, through electronic patient records.

According to Nolte and McKee (2008), the breadth of integration depends on the scope of the integration process. It ranges from the integration of care for individuals, specific conditions or care groups, or an entire population. Similar to this, the three levels at which integration can be pursued are micro-, meso- and macro-. Micro-level integration aims to deliver coherent care for the individual, which can be achieved through personalized care plans. Meso-level integration seeks to provide integrated care to a particular care group with the same illness or conditions. The objective of macro-level integration is to deliver integrated care to an entire population through tailoring services according to the population needs (Curry & Ham, 2010).

Integration of care can be categorized according to its intensity (Nolte & McKee, 2008). While partial integration creates ties to support integration between two sectors to improve coordination, full integration combines health and social sectors into a new organizational model.

The distinction is also made between horizontal and vertical integration. Horizontal integration focuses on linking similar levels of care that support a specific client group. Vertical integration ties care providers across primary, community hospital, and tertiary care services to deliver best practice care and care transitions between providers (Leutz, 1999).

#### *Models of integrated care*

Integrated care models range from disease-specific and individual models to population-based models (Bodenheimer, 2008). Group- and disease-specific models include the chronic care model, integrated care models for elderly and frail, and disease management programs (WHO, 2002; Ham et al., 2008; WHO, 2016). Individual integrated care models cover personal care planning, case management, and patient-centered medical home (American Case Management Association, 2002; Curry & Ham, 2010). Population-based models are currently implemented by Kaiser Permanente and Basque country (Pines et al., 2015; Polanco et al., 2015).

While the distinctive features and core components of integrated care are possible to identify, there is no single organizational approach that best supports integrated care (Goodwin et al., 2014). The development of any integrated care model is solidly contextually-bound. Integrated care models can only succeed when taking into consideration the needs and characteristics of the population it seeks to serve (WHO, 2016).

### **3. Integrated care in social and health care in Finland**

Integrated care is mean organizational models designed to create collaboration within and between the different care sectors at the funding, administrative and/or provider levels (Kodner & Kyriacou 2000).

In Finland, the integration of social and health care services has taken centre stage in both the policy and practice arenas. The integration of social and health care services is considered a key method for improving the quality of care and services as well as organizing them efficiently and cost-effectively. This requires that the client's needs are assessed as a whole and information flows smoothly between the care providers. The needs of many client groups, for example mental health client and older people, are many and varied, and it is impossible for anyone professional to assume full responsibility: integrated care is needed. (Couffinhal et al. 2016.)

In Finland, municipalities are responsible for both social and health care services, however in many cases there remains limited coordination. Insufficient integration of social and health services is a well-known problem in many countries, especially for frail older people and people with multiple chronic conditions. With 10% of clients responsible for around 80% of costs in Finland there is clearly great scope for improvement regarding integration and coordination. (Couffinhal et al. 2016.)

### **4. Integrated care in older people services**

In Finland as well as many other countries it is now important to move towards integrated care for many client groups. Integrated care is particularly important to older people, for number of reasons. First, it is these people who are most likely to have multiple social and health care needs, which are influenced by physical, psychological, social and environmental factors that require multiple service responses (e.g. Eloranta et al. 2008, Ryan et al. 2009). Second, older people are frequent users of health services and recent research has shown that frequent users of health services are also more likely to use social services (Markle-Reid et al. 2006, Lemetti et al. 2017). Third, health professionals often have to take account of social needs when deciding which services to refer older people to (Dempsey & Bekker 2002, Lemetti et al. 2017). A further reason why the collaborative approach to care delivery is

pertinent for older people is that the population is ageing rapidly and older persons themselves are demanding a better quality of care (Vaarama & Pieper 2006, Lemetti et al. 2019).

In older people care, integrated care is important because it is estimated that there are over 500 million people aged 60 and over worldwide. Collaboration between people in different care organizations and different professional group aims to provide seamless, functional good quality services within effective service chains of care to enable older people to live at home independently. (WHO 2013.)

## **5. Involved parties**

Involved parties Alma Mater Europe Maribor Slovenia, University of Applied Sciences Valencia Spain, Jagiellonian University Krakow Poland, University Graz Austria, Kristiania University Oslo Norway, Salford University Manchester UK, University of Applied Sciences Turku Finland, University of Applied Sciences Utrecht The Netherlands (secretary), Rotterdam Stroke Service The Netherlands, Vilans National Centre of Expertise for Long-term Care The Netherlands, NIVEL Netherlands Institute for Health Services Research, International Foundation of Integrated Care IFIC.

## **6. Conclusion**

Efforts to move towards integrated care in social and health care have been met with increased interest and enthusiasm in recent years. This will increase the focus to improve care and population health while containing costs. However, there is a need to better understand different integrated care approaches for social and health care and guide future implementation of new integrated care models. For example, poor mental health considerably impairs the well-being of the population and has considerable economic consequences like absence from work, early retirement, and productivity losses.

It is now essential to move towards integrated care for many client groups e.g., mental disorders. In this, professionals with different training backgrounds co-ordinate their expertise in providing care for their shared clients. It provides a safe nexus for the exchange of knowledge and opinions, as well as a framework for reaching a consensus about

appropriate health care delivery for a particular client or client cohort. The client should have immediate access to integrated care, with a focus on rehabilitation in a patient's social roles.

## **References**

- American Case Management Association. (2019). Definition of case management.
- Bodenheimer, T. (2008). Coordinating care - a perilous journey through the health care system. *The New England Journal of Medicine*, 358(10), 1064-71.
- Bruce, D., Parry, B. (2015). Integrated care: a Scottish perspective. *London Journal of Primary Care (Abingdon)*, 7(3), 44-48.
- Couffinhal, A., Cylus, J., Elovainio, R., Figueras, J., Jeurissen, P., McKee, M., Smith, P., Thomson, S. & Winblad, U. (2016). International expert panel pre-review of health and social care reform in Finland. Reports and Memorandums of the Ministry of Social Affairs and Health 2016:66.
- Cringles, M. C. (2002). Developing an integrated care pathway to manage cancer pain across primary, secondary and tertiary care. *International Journal of Palliative Nursing*, 8, 247-279.
- Curry, N., Ham C. (2010). Clinical and service integration. The route to improved outcomes. The King's Fund.
- Dempsey, O., Bekker, H. (2002). Heads you win, tails you lose: A critical incident study of GPs' decisions about emergency admission. *Family Practice* 19, 611-615.
- Eloranta, S., Arve, S., Routasalo, P. (2008). Multiprofessional collaboration promoting remaining capacity of older home care clients: Perspectives of older clients. *International Journal of Older People Nursing* 3, 88-95.
- Evers, S. M., Paulus, A. T. (2015). Health economics and integrated care: a growing and challenging relationship. *International Journal of Integrated Care*, 15, e024.
- Goodwin, N. (2016). Understanding Integrated Care. *International Journal of Integrated Care*, 16(4), 6.
- Goodwin, N., Dixon, A., Andreson, G., Wodchis, W. (2014). Providing integrated care for older people with complex needs. Lessons from seven international case studies.
- Ham, C., Glasby, J., Parker, H., Smith, J. (2008). Altogether now? Policy options for integrating care. Health Services Management Centre.
- Kodner, D. L., Kyriacou, C. K. (2000). Fully integrated care for frail elderly: two American models. *International Journal of Integrated Care*. DOI: <http://doi.org/10.5334/ijic.11>

- Lemetti, T., Voutilainen, P., Stolt, M., Eloranta, S., Suhonen, R. (2017). Nurse to nurse collaboration on continuity of older people nursing care chain: qualitative study. *International Journal of Integrated Care*, 17(1), 5.
- Lemetti, T., Voutilainen, P., Stolt, M., Eloranta, S., Suhonen, R. (2019). Older patients' experiences of nurse-to-nurse collaboration between hospital and primary healthcare on older people care chain. *Scandinavian Journal of Caring Science*, Jan 10. doi: 10.1111/scs.12653. [Epub ahead of print]
- Leutz, W. N. (1999). Five laws for integrating medical and social services: lessons from the United States and the United Kingdom. *Milbank Quarterly* 77(1), 77–110.
- Lewis, R., Rosen, R., Goodwin, N., Dixon J. (2010). *Where next for integrated care organizations in the English NHS?* London: The King's Fund.
- Lewis, M. (2015). Integrated care in Wales: a summary position. *London Journal of Primary Care (Abingdon)*, 7(3), 49–54.
- Markle-Reid, M., Weir, R., Browne, G., Roberts, J., Gafni, A., Henderson, S. (2006). Health promotion for frail older home care clients. *Journal of Advanced Nursing* 54, 381- 395.
- Ministry of Social Affairs and Health. [http://www.euro.who.int/\\_\\_data/assets/pdf\\_file/0005/322475/Integrated-care-models-overview.pdf](http://www.euro.who.int/__data/assets/pdf_file/0005/322475/Integrated-care-models-overview.pdf)
- Nolte, E., McKee, M. (2008). *Caring for people with chronic conditions: a health system perspective*. Copenhagen: WHO on behalf of the European Observatory on Health Systems and Policies.
- Pines, J., Selevan, J., McStay, F., George, M., McClellan, M. (2015). *Kaiser Permanente – California: A Model for Integrated Care for the Ill and Injured*. The Brookings Institution.
- Polanco, N.T., Zabalegui, I.B., Irazusta, I.P., Solinís, R.N., Del Río Cámara, M. (2015). Building integrated care systems: a case study of Bidasoa Integrated Health Organisation. *International Journal of Integrated Care*, 15.
- Ryan, A. A., McCann, S., McKenna, H. (2008). Impact of community care in enabling older people with complex needs to remain at home. *International Journal of Older People Nursing* 4, 22-32.
- Spicer, J. (2015). Integrated care in the UK: variations on a theme? *London Journal of Primary Care (Abingdon)*, 7(3), 41–43.
- Vaarama, M., Pieper, R. (2006). *Managing Integrated Care for Older Persons. European Perspectives and Good Practices*. STAKES & EHMA. Gummerus Printing, Vaajakoski, Finland.



World Health Organization. (2002). Innovative Care for Chronic Conditions: Building Blocks for Action.

World Health Organization. (2013) Towards people-centered health systems: An innovative approach for better health outcomes. Available at: [http://www.euro.who.int/\\_\\_data/assets/pdf\\_file/0006/186756/Towards-people-centred-health-systems-an-innovative-approach-for-better-health-outcomes.pdf](http://www.euro.who.int/__data/assets/pdf_file/0006/186756/Towards-people-centred-health-systems-an-innovative-approach-for-better-health-outcomes.pdf)

World Health Organization. (2016). Integrated care models: an overview. Working document October 2016 Health Services Delivery Programme Division of Health Systems and Public Health.

## Healthy Neighbourhoods: Health Promotion and Prevention in Urban Neighbourhoods

Joachim Westenhöfer<sup>1</sup>, Johanna Buchcik<sup>1</sup>, Jana Borutta<sup>1</sup>

<sup>1</sup>Competence Center Health, Department Health Sciences, Hamburg University of Applied Sciences, Germany

---

### **Abstract**

*Background: Maintaining good quality of life in urban neighbourhoods is one of the biggest challenges. The project "Healthy Neighbourhoods - Health Promotion and Prevention in Urban Neighbourhoods" (07/2017 - 12/2020) aims to describe and improve health and quality of life of citizens living in neighbourhoods with different socio-economic statuses.*

*Method: To examine the possible association between socio-economic status (SES) and health, a cross-sectional survey in six urban neighbourhoods with "very low", "low", "middle" and "high" social statuses was conducted.*

*Results: In July 2019, a preliminary dataset with 700 respondents was available for analysis. Analyses of covariance showed that physical health-related quality of life was impaired in neighbourhoods with very lower SES, while body mass index was increased. There were no significant differences in mental health-related quality of life.*

*Discussion The results confirm that neighbourhoods with low and very low SES should be primary targets for interventions of health promotion and prevention. To ensure a participative approach for the development of such interventions, the results will be presented to and discussed with residents and other relevant stakeholders of the target neighbourhoods in order to identify the appropriate interventions policies.*

**Keywords:** health promotion, urban neighbourhoods, health-related quality of life, .

---

## 1. Introduction

Urbanization is one of the global megatrends that characterize the current development of mankind. At the beginning of the 20<sup>th</sup> century, only about 10 percent of the world's population were living in urban areas. In 2015, this percentage had increased to about 54 %, and it is predicted to increase to 60 % in 2030 and to 66 % by 2050 (World Health Organization & UN Habitat, 2016, p. 14). Ensuring and enhancing health and well-being of the population living in urban areas is an important and demanding challenge. The neighbourhoods in which people live are important determinants of health and well-being. They include several elements and processes and the interaction between them, as illustrated in figure 1 (Barton & Grant, 2006).

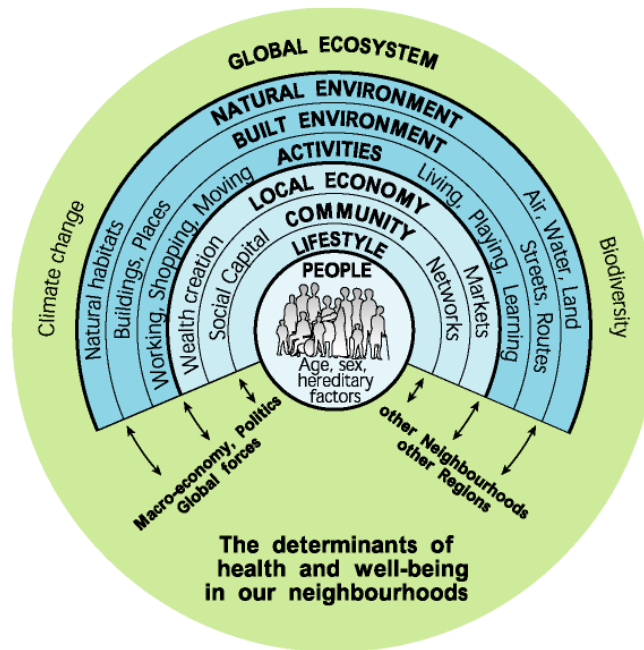

Figure 1. Determinants of health in neighbourhoods . Source: Barton & Grant (2006) inspired by Dahlgren & Whitehead (1991)

Neighbourhoods that are socio-economically disadvantaged often present complex problems of the social, economic, infrastructural and built environment. Often, people with low socio-economic resources are living in such neighbourhoods: unemployed, migrants, single parent families and large families. Often there is a lack of recreational facilities, play grounds and opportunities for physical activity. In addition, environmental health risks such as high traffic load, heightend burden of noise and pollution and poor safety levels are often present in such neighbourhoods (Böhme, Kliemke, Reimann, & Süß, 2012). Therefore such

neighbourhoods should be a primary target of health promotion interventions, not only covering behavioural approaches but also environmental interventions.

The project “Healthy Neighbourhoods” in Hamburg aims to develop and evaluate such health promoting interventions in two socially deprived neighbourhoods. The development of the interventions is informed by (1) a survey of attitudes, perceptions and behaviours of residents and comparison to other less deprived neighbourhoods, (2) structured audits of environmental characteristics of the neighbourhoods and available statistical data, (3) analysis of statutory health insurance data, (4) a qualitative analysis with stakeholders of other local health promotion and prevention projects, (5) a systematic review of community intervention projects, and (6) a participatory process involving stakeholders and residents in the intervention neighbourhoods.

The present paper reports on a preliminary interim analysis of the first of the six mentioned elements, the residents’ survey in 6 urban neighbourhoods of Hamburg. The purpose of the survey is to inform the development of interventions by identifying needs, analyzing the relation between socio-economic status of neighbourhoods, modifyable protective and risk factors for health and to build the basis for the future evaluation of the interventions. The survey was developed according to the model outlined in figure 2. We assume that there is a complex interaction between the perceived characteristics of the neighbourhoods and the residents’ health behavior which together influence their health and well-being. Therefore, a questionnaire was developed that includes an assessment of walkability, community sense, nutrition, physical activity, alcohol and tobacco consumption, resilience, health-related quality of life as well as the socio-economic and the socio-demographic status. However, the present paper will be limited to results related to some indicators of health and the socio-economic status of the neighbourhoods.

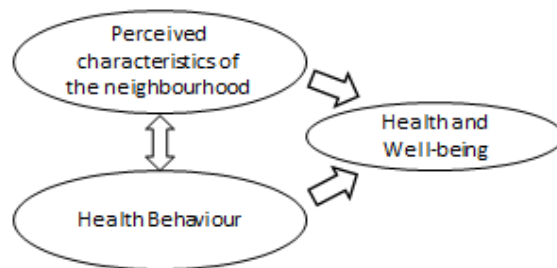

Figure 2. Underlying model for the development of the residents’ survey

## 2. Methods

The present study took place in the City of Hamburg, Germany. Hamburg is divided in 941 statistical districts which are areas with up to 6000 inhabitants. Hamburg has set up a process which is called social monitoring in order to identify neighbourhoods with a need for further urban development. Therefor statistical districts are grouped into 4 levels of socio-economic status SES (very low, low, middle and high) based on 7 indicators (Freie und Hansestadt Hamburg, 2018): (1) children and adolescents with migration background; (2) children of single parent families; (3) recipients of basic social security benefits; (4) unemployed; (5) children receiving basic social security benefits; (6) elderly persons (65 years and older) receiving basic social security benefits and (7) portion of pupils leaving schools with low educational levels.

For the current project we randomly selected 6 statistical districts as investigation areas which fulfilled the following criteria: (1) 2000 or more inhabitants and (2) no recent health related projects (with an annual budget of more than 10,000 € in the last 3 years), and (3) two areas with a very low SES, two with low SES, one with middle and one with high SES according to the social monitoring report of 2017 (Freie und Hansestadt Hamburg, 2018). For each of these 6 neighbourhoods a list of randomly selected 800 subjects was retrieved from the city's residents' registration office. These subjects were invited to participate in a standardized face to face interview (30 – 40 minutes) or to fill out the interview questionnaire themselves if they preferred. Participant gave written informed consent and were paid 10 € in compensation for their time and effort. The study protocol was approved by the ethical committee of the Competence Center Health of the Hamburg University of Applied Sciences. The survey was conducted between May 2018 and July 2019.

The questionnaire included among other sections (see figure 2) questions on socio-demographic data, self-reported weight and height, and the Short-Form SF12, a standardized and well validated instrument to assess health-related quality of life (HRQoL) (Ware, Kosinski, & Keller, 1996; Morfeld, Kirchberger, & Bullinger, 2011). From the SF12 two component scores are computed, one measuring physical HRQoL, the other mental HRQoL. Both scores are standardized to a population mean of 50 with a standard deviation of 10. Body Mass Index BMI was calculated from self-reported weight and height using the standard formula  $BMI = \frac{kg}{m^2}$ . Migration background is a dichotomous categorial variable with the value yes=1 if one of the parents was born in a country other than Germany, and no=0 if both parents were born in Germany.

Statistical analyses were computed using IBM SPSS Version 25. Descriptive statistics are reported as means  $\pm$  standard deviations for interval scaled variables and percentages for categorial variables. Differences between the 6 urban neighbourhoods were analysed using

analyses of variance for age and a chi-square tests for sex and migration background. For HRQoL and BMI as dependent variables, analyses of covariance using sex, age and migration background as covariates were computed. Estimated marginal means are shown together with 95 % confidence intervals. Only male and female subjects were included in analyses which involved sex. In addition, since several subjects did not answer all questions, the number of subjects in the reported analyses is usually less than 700, as we used the listwise exclusion of missing data, e.g. we excluded subjects if they had missing data on one or more of the variables of the respective analysis.

### 3. Results

The current dataset comprises 700 subjects. 389 (55.6 %) are females, 303 (43.3 %) are males, 2 are divers, and 6 subjects did not disclose their sex. The distribution of sex did not differ significantly between the 6 neighbourhoods (Chi-square = 6.3; df = 5; p = 0.28). However, average age and the portion of subjects with migration background differed significantly between the 6 neighbourhoods (age: F = 21.8; df=5/642; p < 0.001; migration background: Chi-square = 105.4; df = 5; p < 0.001) (see table 1).

**Table 1. This is the style for table captions (Times New Roman 9pt bold). Table captions should appear above tables.**

Neighbourhood	Number of subjects for age/migration background	Neighbourhood Socio-Economic Status	Age mean ± standard deviation	Percentage of subjects with migration background
Wilhelmsburg	52/73	Very low	39.1 ± 15.3	79.7 %
Rahlstedt	121/126	Very low	50.9 ± 14.0	24.6 %
Hamm	123/124	Low	40.7 ± 16.8	37.4 %
Lohbrügge	102/107	Low	45.2 ± 16.9	51.0 %
Stellingen	132/138	Middle	43.2 ± 13.8	41.8 %
Sasel	118/124	High	57.8 ± 15.8	10.0 %
Total	648/692		46.8 ± 16.6	37.2 %

The average score for physical component of health-related quality of life differed significantly between the 6 neighbourhoods after adjustment for sex, age and migration background (F=5.6; df=5/550; p < 0.001; partial eta-square=0.05). As illustrated in Figure 1, the average physical health-related quality of life is lower in the neighbourhoods with

lower SES, particularly in those with very low SES, as compared to neighbourhoods with higher SES. The corresponds with the tendency for average BMI. Neighbourhoods with very low SES show higher average BMI than neighbourhoods with higher SES (Figure 2). Average BMI, adjusted for sex, age and migration background is significantly different between the 6 neighbourhoods ( $F=5.7$ ;  $df=5/550$ ;  $p < 0.001$ ; partial eta-square=0.05). In contrast to these indicators of physical health, the average score of the mental health-related quality of life, adjusted for sex, age and migration status, did not differ significantly between the 6 neighbourhoods ( $F=1.5$ ;  $df=5/550$ ;  $p = 0.173$ ; partial eta-squared = 0.01)

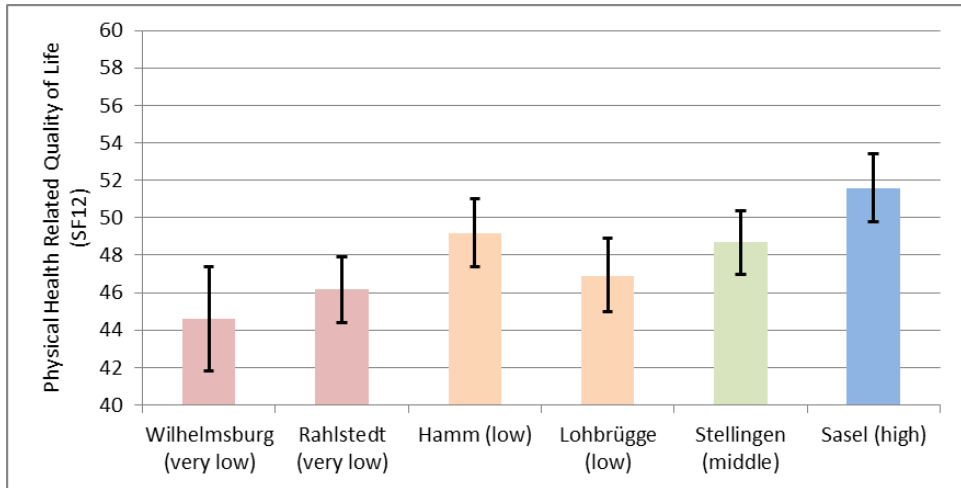

Figure 3. Average score of physical health-related quality of life (SF12) (with 95% confidence intervals) adjusted for sex, age and migration background.

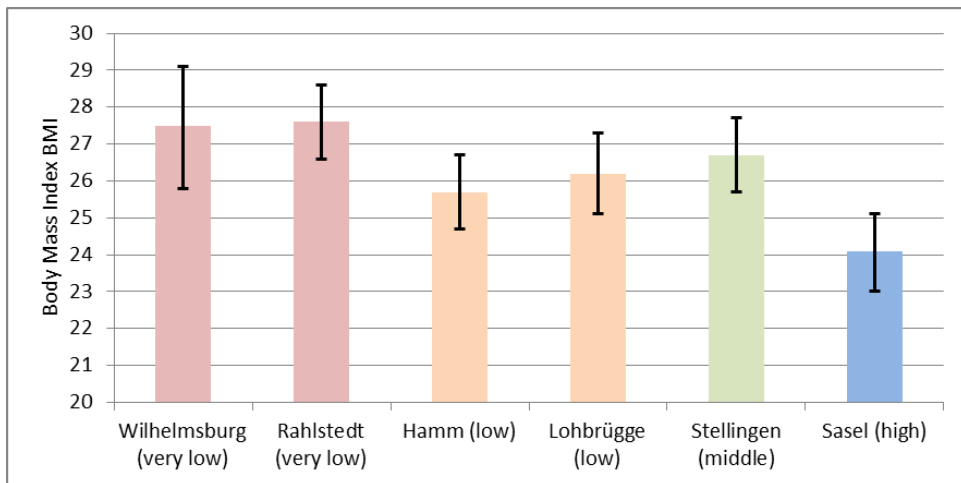

Figure 4. Average Body Mass Index (with 95% confidence intervals) adjusted for sex, age and migration background.

## 4. Discussion

These preliminary interim results of the present study indicate that the socioeconomic status of urban neighbourhoods in Hamburg is associated with differences in the health of its inhabitants. Lower socioeconomic status is associated with indicators of poorer physical health, more specifically lower physical health-related quality of life and higher body mass index. In contrast to these relationships the mental health-related quality of life did not differ significantly between neighbourhoods with different socio-economic status.

The present study and the presented results have some limitations which are important to note. First of all, we are presenting results from a cross-sectional study. Therefore, the reported associations are correlations, and causal interpretations are not justified. Secondly, we are presenting preliminary results from an interim analysis of incomplete data, as the data collection, data entry and data clearance was still in progress at the time of writing. Thus, results might change, when the full dataset becomes available. However, the final dataset will presumably add less than a 100 additional subjects to the 700 subjects in the current analyses. Third, we are presenting results on only a very limited set of variables. Although we have adjusted our analyses for important determinants such as sex, age and migration background, we cannot exclude the possibility that other effect modifiers or confounders are present that impair the validity of the results.

Despite the limitations of the present study, it might be expected that these results can be generalized to other cities as well. In summary, the presented results confirm that the physical health of the residents in neighbourhoods with low socio-economic status is impaired as compared to better off neighbourhoods, and that neighbourhoods with low socio-economic status should be an important focus of intervention for health promotion and disease prevention.

As a next step, the results will be presented to and discussed with residents and other relevant stakeholders of the target neighbourhoods in order to start a participatory process to identify appropriate and relevant interventions policies for health promotion and prevention in the setting of urban neighbourhoods.

## References

- Barton, H., & Grant, M. (2006). A health map for the local human habitat. *Journal of the Royal Society for the Promotion of Public Health*, 126(6), 252–261. <https://doi.org/10.1177/1466424006070466>



- Böhme, C., Kliemke, C., Reimann, B., & Süß, W. (2012). *Handbuch Stadtplanung und Gesundheit*. Bern: Huber.
- Dahlgren, G., & Whitehead, M. (1991). *Policies and strategies to promote social equity in health*. Retrieved from [http://s2.medicina.uady.mx/observatorio/docs/eq/li/Eq\\_2007\\_Li\\_Dahlgren.pdf](http://s2.medicina.uady.mx/observatorio/docs/eq/li/Eq_2007_Li_Dahlgren.pdf)
- Freie und Hansestadt Hamburg (Ed.). (2018, January). *Sozialmonitoring Integrierte Stadtentwicklung. Bericht 2017*. Retrieved from <https://www.hamburg.de/contentblob/10271310/ff3ff757e66542aed8c9294fe32de604/data/d-sozialmonitoring-bericht-2017.pdf>
- Morfeld, M., Kirchberger, I., & Bullinger, M. (2011). *SF-36. Fragebogen zum Gesundheitszustand*. (2.). Göttingen: Hogrefe.
- Ware, J., Kosinski, M., & Keller, S. D. (1996). A 12-Item Short-Form Health Survey: Construction of scales and preliminary tests of reliability and validity. *Medical Care*, 34(3), 220–233.
- World Health Organization, & UN Habitat. (2016). *Global report on urban health: Equitable, healthier cities for sustainable development*. Retrieved from <https://apps.who.int/iris/handle/10665/204715>

## New approach for resource allocation indigital healthcare 4.0

Balázs Kocsi<sup>1</sup>, László Pusztai<sup>1</sup>, Istvan Budai<sup>1</sup>

<sup>1</sup>HU University of Applied Sciences Utrecht, The Netherlands.

---

### **Abstract**

*Abstract: The examination and automation opportunities in healthcare processes, which aims at reducing patient journey and their waiting time, while increasing the utilization of medical equipment as well as monitoring patients.*

*Waiting times are playing a significant role in the total process time of patient care. One of the main reasons is the insufficient resource allocation. This research presents a methodological improvement which supports decision making in digital health processes. The current research provides a methodology that makes weekly human resource scheduling more efficient than before.*

*With the combination of process mining and operations research, we developed a weighted forecast for the probable number of patients. During the research we processed historical data as well as we identified the bottlenecks in the examined health process. Furthermore, we took the causality into account.*

*In today's fast-paced societies, IT-based solutions are more and more frequently used in healthcare, with the aim of reducing risks and increase patient satisfaction. The method created by us offers a fast, precise and efficient solution to decision making in digital health processes.*

**Keywords:** *Process Mining, Risk analysis, scheduling.*

---

## **1. Introduction**

Hospitals have to focus on high quality care and cost reduction at the same time. Hospitals face many challenges nowadays such as increasing costs, strict standards, lack of human resources. Hospitals are forced to improve the quality of care their services under financial pressures by governments. Can business process improvement and process mining be the solution to the previously mentioned problems? Business process improvement is the field of increasing efficiency of organizations and decrease operation costs Anyanwu et al. (2003). The goal of process mining is to extract process knowledge based on “event-logs” from different information systems. Event logs consist of information about the start/end dates of a particular activity, required resources and actors Anyanwu et al. (2003).

The aim of this paper is to present a case study in the field of healthcare. In this case study process mining was applied within business process improvement frameworks. The examined case is a sample identification process in the Department of Medical Microbiology from the receiving sample to the point of consulting with the doctor about the result. Process mining was used to reveal bottlenecks in the sample identification process, after that resource allocation was carried out to balance out the workload of human resources. The amount of the incoming samples was predicted, and the scheduling of workers was calculated with the new balanced workflow.

## **2. Literature review**

### *2.1. Business Process improvement and Process Mining*

Business Process Improvement is a part of the Business Process Management System. Business Process Management focuses on solving current business problems by improving the related processes Malinova, M., & Mendling, J. (2018). Many companies follow the Business Process Management (BPM) cycle to manage business processes. This cycle consists of 6 different steps. These are the following:

1. process identification
2. process discovery
3. process analysis
4. process redesign
5. process implementation
6. process monitoring

The BPM life-cycle provides a logical way to improve business processes. One of the most important parts of BPM is process modelling Malinova, M., & Mendling, J. (2018). Sometimes the models are not structured and at a wrong abstraction level. Another barrier of good modelling is that it requires skilled process analysts. Without a good process model it

is not possible to execute an improvement well. At this point, process mining can help us. In the service sector, such as health care it, is not easy to model processes because they are known to be commonly chaotic and unidentified.

Process mining attempts to eliminate the previously mentioned limitation of process modelling. With the use of process mining the reality can be presented as a petri net, which is a good starting point of modelling. The following data are required for process mining: Case ID, timestamp, name of activity, resources. Figure 1 shows an example.

Case id	Event id	Properties			
		Timestamp	Activity	Resource	Cost ...
1	35654423	30-12-2010:11.02	register request	Pete	50 ...
	35654424	31-12-2010:10.06	examine thoroughly	Sue	400 ...
	35654425	05-01-2011:15.12	check ticket	Mike	100 ...
	35654426	06-01-2011:11.18	decide	Sara	200 ...
	35654427	07-01-2011:14.24	reject request	Pete	200 ...

Figure 1: Example Event Log. Source: Van der Aalst (2016)

The case is identified by Case ID e.g. a sample is received. Then, the sample preparation, and several activities that are executed by the workers. The next two columns demonstrated the information about the time and activity duration is important to generate the right sequence.

The process discovery technique automatically generates and learns a process model from an event log database. Figure 2 shows the generalized model of discovery technique.



Figure 2: Process discovery. Source: Van der Aalst, et al. (2011)

The result of the discovery is a fact-based ‘as-is’ process model that presents how the process works in reality. It is based on historical data Burattin, A. (2015). Compared to the traditional process model technique, process mining discovery makes it possible to model unstructured processes Pourmasoumi, A., & Bagheri, E. (2017).

## 2.2. Generalized Network Models

Generalized network models are applicable in several fields of use, such as manufacturing or healthcare, where parallel or sequential activities can be carried out Chachra (1979), Murty

(1992). The purpose of these kind of models is to either ascertain a material flow, or determine a probable total process time (TPT) or total process cost (TPC) based on Pusztai et al (2018). These models usually determine the direction of the objective, which are usually related to cost. In this kind of model nodes are for machines or events, while arrows display material flow or activities.

The generalized **objective** of the model can be seen in the equation below:

$$\min z = \sum x_{i,j}$$

where  $x_{i,j}$  is the representation of the unit cost/unit processing time of a given activity.

To the subjects of:

$$\sum_{j=1}^n x_{i,j} \lambda_{i,j} - \sum_{i=1}^n x_{i,j} - I_i \geq 0$$

where:

- $x_{i,j}$  illustrates the gross material flow,
- $\lambda_{i,j}$  demonstrates the possible performance (within the range of 0-1),
- $I_i$  displays the Inventory in the node  $i$ .

### 3. Problem statement and aim of the research

Two analysts deal with the blood and urin samples identification at the department of Microbiology. Unfortunately, the workflow is unbalanced and the analysts are overloaded. That is why some mistakes can occur during the procedure such as: wrong identification, machines breaking down, sample sorting problems. The goal of the project is to try out a new approach with the use of which bottlenecks can be determined and additional workforce can be assigned for problematic stations to equalize the unbalanced work and eliminate the problems.

### 4. Material and methods

The scope of the research is the bacteria identification procedure based on 2 different types of samples, blood and urine. In the first step the process was modelled and analysed by process mining discovery methods based on event-logs. The software provided information about the bottlenecks and the workflow. In the next step the resource allocation was improved by Generalized Network Problem (GNP) method. The amount of the incoming samples was predicted for the next period, and the workload was calculated with the new scheduled workflow.

In this research process mining and Generalized Network Problem method were combined to extract information from the process and find solution to optimal scheduling for decrease overloaded human resources.

A random chosen daily event-logs were collected for process discovery.

## 5. Result

The process model was generated by process discovery. Based on the process model 3 paths can be seen. The first is when the blood sample result is negative, in this case 3 activities were executed from “incoming sample” to “Communication” the negative result. If the blood sample result is positive the previous process is extended with the following main activities:

- MALDI TOF identification,
- antibioticum resistans examination.

The second and the third paths are about the urin sample identification. There are two type of urin sample identification procedures. The first is the urin native sample when inoculate the agar plates with urin is necessary. The middle path demonstrate this process. The second type of urin sample arrived in uricult. The path on the left hand side demonstrates this process.

The numbers beside the arrows present the output of cases' frequencies. The numbers in the middle of the rectangle display the occurrence of a certain activity. The figure 3. present the discovered paths.

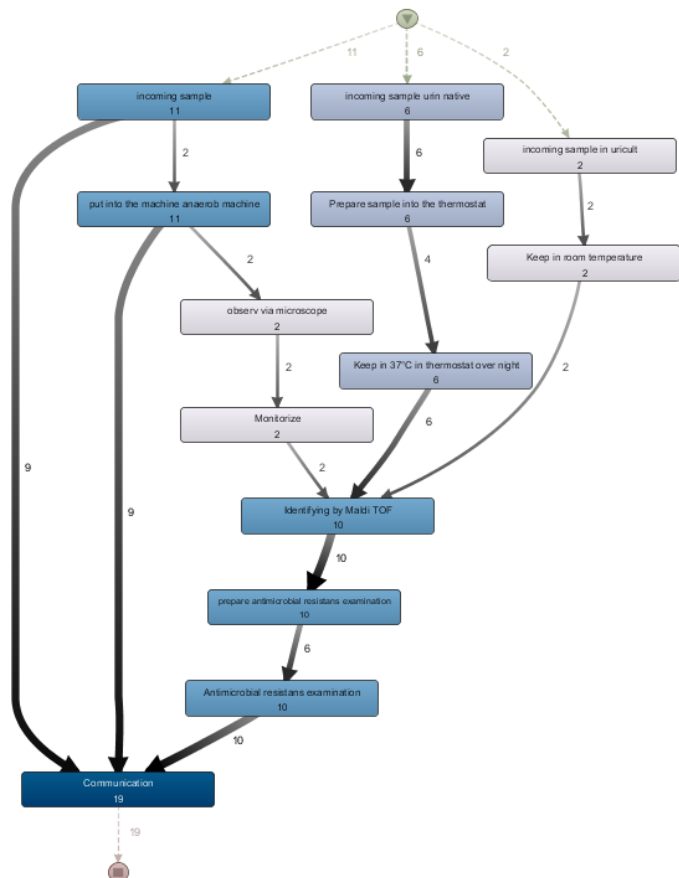

Figure 3: Process model: discovered paths

The figure 3 presents that there are 11 blood and 8 urin samples out of 19. Two positive blood sample results were communicated and there were 9 negative blood sample results. 6 urine native samples arrive and 2 urine uricult samples arrive. The performance of human resources are appeared from the analysis of the process model. The “prepare antimicrobial resistans

examination” activity is the most frequently and it takes the longest time. So this is the bottleneck. This activity occurs on every path when the sample is positive. The table 1. presents the data of the bottleneck activity.

**Table 1: prepare antimicrobial resistans examination activity data**

Frequency	Performance
Absolute frequency: 10	Total duration: 107 mins
Case frequency: 10	Median duration: 7 mins
Max repetitions: 1	Mean duration: 10.7 mins
Wrokers: 1	Max duration: 44 mins
	Min duration: 4 mins

Source: based on the authors’ result (2019)

The process model and the result of process analysis are the input of the GNP model. The GNP model provide the sample flow. The result of network provides that if additional worker is implemented to the bottleneck the total duration of the activity can be descended by 50%/worker. The figure 4. presents the network modell of the process.

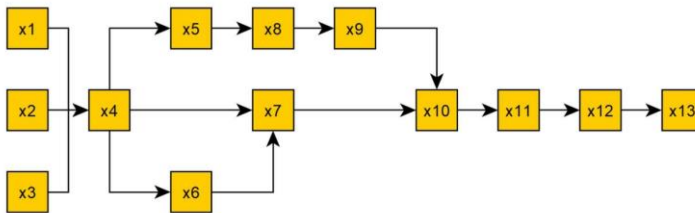

Figure 4: Generalised Network Model of the process

If we add an extra human resource to this activity, total activity time of sample identification can be reduced, because there is no any resource which means bottleneck in this process step.

The bottleneck activity data will change in the improved state. The table 2 present the improved activity data.

**Table 2: prepare antimicrobial resistans examination improved activity data**

Frequency	Performance
Absolute frequency: 10	Total duration: 54 mins
Case frequency: 10	Median duration: 7 mins
Max repetitions: 1	Mean duration: 10.7 mins
Workers: 2	Max duration: 42 mins
	Min duration: 4 mins

Source: based on the authors’ result (2019)

## 6. Concept for the new approach

The following data are necessary to the GNP model to determine the lowest TPT: cost/cycle times of activity, structure of process. The research reveal the fact that process discovery technique can provide the input data for the GNP model. GNP provide the best material flow where TPT is minimum. Based on the optimum material flow, the daily tasks for the microbiologists, analysts and assistants can be determined by the start of the shift. If a cloud is implemented the information flow is easy between the participant. Futhermore, the combination of process mining and calculated of operations research model can be automated by Robotic Process Automation (RPA). Figure 5 presents the new concept with the use of it Business Processes can be optimized and the results can be communicated with the stakeholders automatically. The new concept is called as Framework for Optimized Process with Integrated Algorithms (FOPIA).

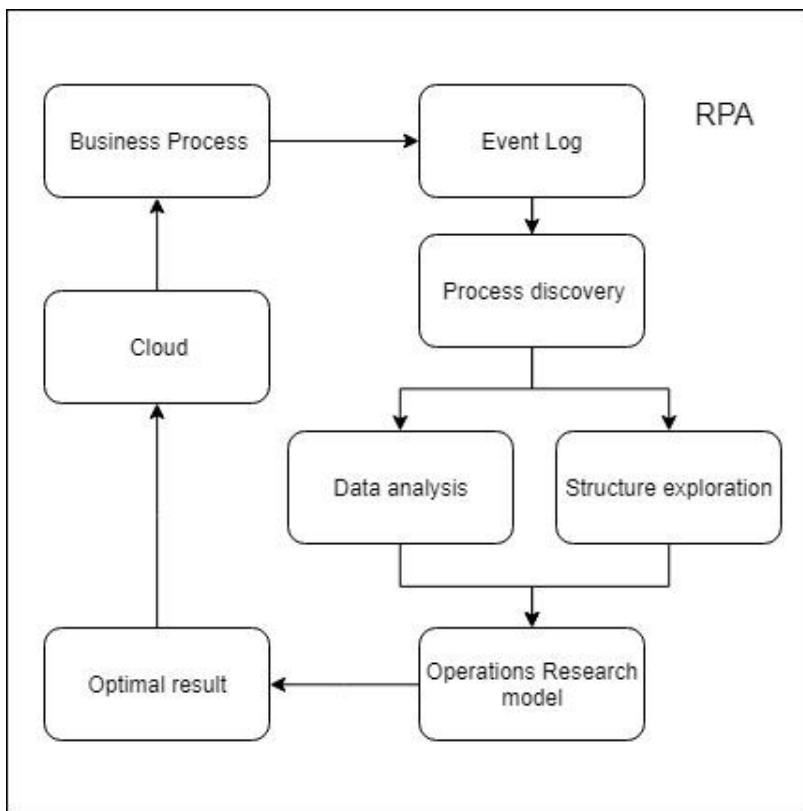

Figure 5: Concepts of Framework for Optimized Process with Integrated Algorithms (FOPIA).



## **7. Conclusion**

Hospitals face with many challenges nowadays. The good scheduling is a fundamental part of the daily operation. A new concepts were applied to schedule a health care process as a business process. The research pointed out that the result of process discovery can be the input of GNP operations research model. So the process mining and the operation research a good combination for optimizing of BP. FOPIA concept provides an automated, integrated system with the use of which the scheduling and the optimal resource allocation is performed and communicated via cloud system.

## **References**

- Burattin, A. (2015). *Process Mining Techniques in Business Environments* (Vol. 207). Cham: Springer International Publishing
- K. Anyanwu, A. Sheth, J. Cardoso, J. Miller, K. Kochut, Healthcare enterprise process development and integration, *Journal of Research and Practice in Information Technology* 35 (2) (2003) 83–98
- K. G. Murty: *Network Programming*, PrenticeHall, Michigan, 1992.
- Malinova, M., & Mendling, J. (2018). Identifying do's and don'ts using the integrated business process management framework. *Business Process Management Journal*, 24(4),
- Pourmasoumi, A., & Bagheri, E. (2017). Business process mining. *Encyclopedia with Semantic Computing and Robotic Intelligence*, 01(01), 1630004.
- Pusztai L., Kocsi B., Budai I., Nagy L.: *Material Flow Optimization With The Application Of Generalized Network Flow Model* (in Hungarian), *Műszaki Tudományos Közlemények* vol. 9. (2018) 203–206
- V. Chachra: *Applications of Graph Theory Algorithms*. Elsevier, 1979.
- Van der Aalst, W. (2016). *Process Mining*. Berlin, Heidelberg: Springer Berlin Heidelberg.
- Van der Aalst, W., Adriansyah, A., Medeiros, A. K. A. de, Arcieri, F., Baier, T., Blickle, T., ... Wynn, M. (2011). *Process Mining Manifesto*. In F. Daniel (Ed.), *Lecture Notes in Business Information Processing: Vol. 99. Business process management workshops: Revised selected papers, part I* (Vol. 99, pp. 169– 194). Berlin: Springer.

## **The Phenomenon and the Characteristics of Precariate in Hungary:**

### **Labormarket situation, Precariate, Subjective health**

**Anita R. Fedor<sup>1</sup>, Renáta J. Erdei<sup>2</sup>,**

<sup>1</sup>Department of Social Sciences, University of Debrecen, Faculty of Health, Hungary

<sup>2</sup>Department of Health Sciences University of Debrecen, Faculty of Health, Hungary

---

#### ***Abstract***

*The paper introduces the labor-market characteristics of 18-70 year-old age group in Nyíregyháza in Hungary. The focus of our research is labor market integration and the related issues like family formation, work attitudes and subjective health status. The theoretical background of this analytical work is based on precariate, a social phenomenon that has not been used widespreadly yet. This study defines precarity as a labour-market uncertainty which includes insecure short-term jobs, fixed-term employment contracts, and lower positions in the labor-market hierarchy.*

*Our main research question is: Is there relevance between the phenomenon of precariate and labor market disadvantage and subjective health status? Our results show a significant correlation between the variables (phenomenon of precariate, labor market situation and subjective health status).*

***Keywords:*** labour market; precariate; subjective health.

---

## **1. Introduction**

The focus of our research is labour market integration and related issues like learning motivation, value choices, health status, family formation, work attitudes and subjective health.

The research took place in Hungary in the North Great Plain Region – Szabolcs-Szatmár-Bereg county, Nyíregyháza.

Due to volume limitations, we do not cover all of our results in this paper. First of all, we present the results of the *Quality of Life Nyíregyháza* study, and the Hungarian Graduate Tracking System study, highlighting the phenomenon of precariate and subjective health. (The Graduate Tracking System database with the permission of the data controller was used for the research) In these studies, the two main target groups were: an 18-70 year-old age group (478 person) and young, higher education graduates (more than 20,000 person).

## **2. Theoretical frameworks**

The theoretical frameworks of the precariate research is characterized by a multi-disciplinary approach, as this topic has sociological, economic, psychological, pedagogical and legal aspects.

The term precariate, as a concept, appeared primarily in the French literature at the end of the 1970s. Similarly to the definition of exclusion, the term has long been characterized by the phenomenon of losing one's footing in society associated with new poverty. The framework of the definition has been narrowing, and today it is most closely related to the workforce, demonstrating an uncertain labor-market situation. The precariate became the focus of academic interest in the early 2000s, and after a brief transient silence, in 2012 as a result of the publication of Gay Standing, the interest for the scientific approach of the phenomenon intensified. (Ferge 2012)

Another important definition we use is one of the key dimensions of quality of life, self-rated health / subjective well-being, which has been shown to be influenced by economic activity, including job satisfaction.

There are many factors which define an individual's quality of life, and among these factors the health plays a prominent role.

Quality of life is a complex concept. Its determining parts are health, financial situation, housing and social relationships, economic activity. Among the factors influencing the quality of life one of the most influential dimensions is the health status of the person, which is often divided into „objective” and „subjective” factors (although in reality they do not exist in this clearly separated form).

A very significant part of the research explores how the health status contributes to the prosperity of the person, how it helps to achieve their goals. The primary objective of the research is to improve the health status of the population as well as to reduce the existing

horizontal and vertical health inequalities. The improvement in the quality of life can be rationalized as health gain for the society. These two main indicators are the increase in the life expectancy and in the increased number of life years (Mihályi, 2003; OEFI, 2004).

In modern societies, it became clear that - despite the huge progress in medicine - health care alone is not able to improve health and the quality of life, it can only cure certain diseases. In improving the health status and the quality of life individuals, local communities and economic activity, labor market situation plays a bigger and bigger role (Jávorné, 2016).

We also know from the Marmot report that reducing health inequalities is primarily a matter of social justice and equity. The report draws the attention of decision-makers to the fact that the lower the social position of an individual, which is influenced by his / her labour market situation, made worse by health (Marmot et al, 2010).

Improving the health status of the population and reducing inequalities can contribute to development, increase economic activity and achieve a positive overall impact on society (Ferge, 2008).

### 3. Research questions

In our research, we have created three research questions.

- 3.1 *The question remains if there are significant labor market disadvantages in the group of young higher education graduates, who have a generally favorable labor-market condition? (R. Fedor 2019)*
- 3.2 *How the uncertainties in the workplace appear in different regions and social groups? (R. Fedor 2019)*
- 3.3 *Are there definite features in the subjective state of health of groups with classic precariate characteristics?*

### 4. Results of research

The participation of the young graduates in the labor-market is favourable, 88% of them worked at the time of the survey. The percentage of those who were not working at the time of the interview, although they had worked previously was 8.4% and 3.4% of them had never worked.

**Table 1. Studying young graduates regarding precarious characteristics**

Labour Market Participation (N= 20 996) (p=0.010)			Distribution according to the Type of the work contract (N=17056) (p=0.000)		
	Female	Male		Female	Male
Working Currently	76.8	82.1	Indefinite, permanent employment contract	71.8	80.1
Never Worked	9.3	8.4	<i>Fixed-term employment contract</i>	<i>24.0</i>	<i>16.2</i>

<i>Not working but have worked previously</i>	<b>13.9</b>	<b>9.5</b>	Casual or contractual employment contract	4.2	3.7
---	-------------	------------	---	-----	-----

Source: Own editing, (2019)

Important question is how labor-market participation is developing, regarding men and women separately. There was a fundamental difference between the answers of full-time and part-time students. Not surprisingly, most of the part-time students were working at the time of the survey, as they usually chose part-time programs in order to match their studies to their job responsibilities. However, it is remarkable that the proportion of women was higher in both part-time and full-time graduates who "were not working at the time of the survey but had worked previously". Although the answers do not reveal the reason for the interrupted labor-market presence, it can be stated that the absence from the continuous labor-market presence, which can clearly be interpreted as a kind of insecurity, is more characteristic to women than to men. (Table 1.)

The same can be said of another precariate indicator, of the occasional, contractual or fixed-term employment contract. This lower security type contract is typical to 19.9%, of full-time men and 28.2% of full-time women. (Table 1)

All in all the results show that precarious features like *fixed-term contract*, *not working but have worked previously* also affect well graduated people, although it is more typical for women than men. (R. Fedor, Toldi 2017; R. Fedor 2019)

**Table 2. Regional Differences**

	<b>Quality of Life in Nyíregyháza (%)</b>	<b>Quality of Life in Cigánd district (%)</b>
<b>How are you satisfied with your present salary, income?</b>		
not at all	11.2	38.5
not satisfied	15.0	15.7
partly satisfied partly not	30.0	20.3
<b>satisfied</b>	<b>31.3</b>	<b>18.1</b>
<b>completely</b>	<b>12.5</b>	<b>7.4</b>
<b>How are you satisfied with working conditions?</b>		
not at all	3.9	14.3
not satisfied	9.0	14.6
partly satisfied partly not	27.0	23.3
<b>satisfied</b>	<b>39.1</b>	<b>29.3</b>
completely	21.1	18,3

Source: Own editing, (2019)

These results confirm our statements regarding regional differences. It can be seen that residents of Cigánd are much more dissatisfied with their payment, their working time and other working conditions. (Table 2)

In 2015, Nyíregyháza became divided into groups based on average age (groups A, B, C), which were examined and compared from several points of view.

Groups with classic precariate characteristics are most likely to be in group C, with respondents aged between 58 and 62 years.

Examining the locally produced quality of life index, the groups show a number of 7.88 in the group A, 6.56 in the group B and 4.33 in the group C.

The difference between the groups was indeed significant ( $p = 0.000$ ). The worst situation in terms of work and activity was found in Group C, with 78.3% of those not employed. The proportion of economically inactive increases from A to C.

Our results conclude that most people in this particular group (c) consider their health to be poor.

## 5. Reflection on research questions

*5.1 Overall it can be said that the phenomenon of the precariate also prevails among the graduates studied. The precariate phenomena show significant differences in gender and educational level, which also justifies the statements of the literature. (R. Fedor 2019)*

*5.2 The personal and regional risk factors of labor market exclusion can develop both in different regions and social groups. (R. Fedor 2019)*

*5.3 The characteristics of economic activity greatly influence income conditions, which affect the health of the individual. In respect of Nyíregyháza, the disadvantage of groups with classic precariate characteristics.*

## References

Ferge, Zs. (2012): Prekariátus Magyarországon. Fordulat 19. 117-125.

[http://fordulat.net/pdf/19/F19\\_Ferge-interju.pdf](http://fordulat.net/pdf/19/F19_Ferge-interju.pdf)

Ferge Zsuzsa (2008): Why are the inequalities in Hungary unusually high?

Esély, 2008/2; 3-14.o

Jávorné Erdei Renáta, (2016.), The quality of life of the population of Nyíregyháza in the light of their health status, PhD dissertation, [http://tsp.etk.pte.hu/portal/wp/File/Doktoriiskola/Teziszfuzetek/Javorne\\_Erdei\\_Renata\\_dissz.pdf](http://tsp.etk.pte.hu/portal/wp/File/Doktoriiskola/Teziszfuzetek/Javorne_Erdei_Renata_dissz.pdf) downloaded October 2018.

Marmot M et al (2010): Fair Society, Healthy Lives – The Marmot Review.

Strategic review of health inequalities in England post-2010  
<http://www.instituteofhealthequity.org/projects/fair-society-healthy-lives-the-marmot-review> downloaded 2015.10.10

Mihályi Péter (2003): Introduction to Health Economics, University of Veszprém, Veszprém

National Institute for Health Development, (2004): Principles of Health Promotion (Basic International Documents on Health Promotion)

Standing, G. (2012): *The Precariat: The New Dangerous Class*. Bloomsbury Academic.  
*ACTA MEDICINAE ET SOCIOLOGICA* 9 : 27 pp. 33-57. , 25 p.

R. Fedor, Anita (2019): The Phenomenon and the Characteristics of Precariate in Hungary. Manuscript.

R. Fedor Anita; Toldi Andrea (2017): Labour market opportunities of women with young children after childbirth. *KONTAKT* 19 : 3 pp. 220-226. , 7 p.

## Virtual Training in Safety and Security – TUAS Visions for Next Generation Learning

Mika Luimula<sup>1</sup>, Roosa Talvitie<sup>1</sup>, Nina Rantalaiho-Kulo<sup>2</sup>

<sup>1</sup>Turku University of Applied Sciences, Finland. <sup>2</sup>Mazin Al-Adawi, Nizwa College of Applied Sciences, Oman

---

### **Abstract**

*The new suggested collaboration is related to the development of learning materials for a virtual environment that can be used in multi-professional exercises for improving safety and security in bodies of water and/or in urban settings. We have identified both national and international needs for virtual training. In particular, safety and security linked to dangerous or hazardous working environments seems to be one of the first domains where virtual training should be widely applied. We are searching for both end-users (such as shipping companies or fire departments) but also researchers from various fields. In order to be able to develop new, innovative learning contents we will need to establish a multidisciplinary team which is able to design and implement suitable educational concepts but which is also able to measure the impact in improved safety and security conditions. In this paper we will use a virtual fire safety training application as an example of a next generation learning tool and method. Finally, we will show our first field experiences from Oman..*

**Keywords:** Maritime Safety, Urban Safety, Virtual Reality, Next Generation Learning, Emergency Services

---



## **1. Background of the topic**

TUAS has participated in various safety and security related projects recently in which needs for virtual training has been identified. TUAS was involved 2018-2019 in a bilateral, Finnish-Romanian capacity building project that was focused on developing and implementing an emergency- operator training programme in Romania. This joint venture, implemented in cooperation with the Romanian Centre for Health Policies Services, was supported both by the Finnish and Romanian Ministries of the Interior. The main outcomes of the project were, in addition to the strengthening of the infrastructure of two simulator-focused dispatcher training centres, a comprehensive curriculum for the dispatcher training programme, state-of-the-art training materials and a strategy for implementing and scaling up of the training programme in Romania.

OnBoard Med - Harmonization of onboard Medical treatment, Occupational Safety and Emergency skills in Baltic Sea Region (Central Baltic 2016-2019) aimed at developing more aligned vocational education programmes in the Central Baltic area. The project has developed 9 courses (varies 2-8 ECTS) in maritime emergency management, medical treatment and occupational safety. The courses are suitable at maritime (seamen, deck officer, maritime engineer) and nursing institution (Nurse, emergency care nurse and public health nurse). The one main idea in this project was the close co-operation between maritime and nursing institutions. Mariners and ship nurses are together a team onboard. They have to cooperate fluently and effectively onboard in emergency care situation. You will find different kind of learning material from contact lessons to videoleasons, different tasks, ideas for workshops, and specific description of the simulation scenarios.

Business Finland funded Allied ICT Finland (AIF) is a collaboration network of Finnish ICT research institutes and their cities, national ecosystems both applying and enabling ICT, thousands of researchers and more than 1200 companies. Digitalization creates vast possibilities for growth, but new ways of agility, investments and partnership models are needed in order to succeed. Finland must be in the vanguard of new technologies and business opportunities. Allied ICT Finland offers a new model of action and investment, which aims to create a billion euro R&D leap. TUAS School of ICT has been participating in this project since 2018. One of the research focus areas has been in virtual safety training (and virtual training centers). TUAS is investing in 2019-2021 around 0.5M€ for AR and VR technologies. This investment enables to establish first virtual training centers with TUAS industrial partners.

It is forecasted that in 2050, two-thirds of the world's population will live in cities and urban areas (United Nations, 2018). Due to the growing environmental concerns, instead of using airplanes, citizens will increasingly be travelling by alternative modes boat or by train. Europe has many big lakes and long rivers that will be facing a growing use of passenger

ships. The development of comprehensive safety and security systems will thus be crucial in the bodies of water (sea, river and lake areas).

Based on the experiences gained from the two ambitious international research and capacity building – focused collaborations that TUAS has been partnering in, it has become evident that the use of state-of-the-art simulation and e-learning techniques, combined with the use of AR and VR technologies, can provide outstanding solutions in education and training in the field of safety and security. The added value of the recourse to these technologies is in particular (but not limited to) the possibilities of simulating situations in challenging environments which might otherwise not be physically feasible (eg maritime safety situations), as well as the possibility of enabling the multiplication of these trainings to a large number of trainees with limited/reasonable costs/resource-efficiency. TUAS is setting up an virtual training centers focused on the thematics of safety and security, and has a long-standing experience in cooperating with international and national maritime safety authorities, research institutions as well as relevant industry partners.

## **2. Problem statement or concrete goals or steps**

TUAS has piloted virtual training with various industrial partners. Typical users in industry have few or no gaming experiences. That's why our partners have been especially interested in fresh solutions which could improve usability, user experience, and user interface design. In this paper, we shortly introduce some of our virtual training applications. In addition, we will focus on a fire safety application which have been tested in Finland but now also in Oman. This case study shows the potential of setting up an international consortium to focus on safety and security training in virtual environments. A project in which we will focus on hands-on-training solution in demanding and hazardous training should standardize virtual training and form basis for new business ecosystem of next generation learning environments.

## **3. Some details and specifics on the basis for the future project**

Currently we have three key pilot projects in marine industry (Figure 1). The first is a maintenance training solution to assist engineers in the engine room, while the second is a gamified crane training for crane drivers, and the third one is a virtual command bridge simulator (Markopoulos et al., 2019).



Figure 1. Three VR training solutions for marine industry.

Before focusing on marine industry we have studied virtual reality in driving inspection (Luimula et al., 2015; Hämäläinen et al., 2017). As a result we created NeuroCar evaluation tool for a simultaneous evaluation of driving acuity and spatial perceptual capacity. In addition, we have developed training solutions for drivers.



Figure 2. System description of the NeuroCar evaluation tool and street view from the NeuroCar training solution.

In this paper, we will focus more on virtual fire safety training which is a part of both marine and urban safety. Our largest safety training field experiment so far has consisted of 169 test subjects (Oliva et al., 2019). In this study, player's task was to escape the building on fire. We showed that this virtual training solution called Virpa is a suitable tool for communication relating to fire safety.

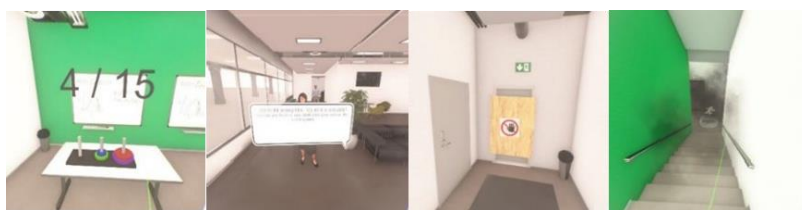

Figure 3. Screen captures from the Virpa game.

As a continuum for Virpa (Figure 3) we have developed a fire safety to learn how to use fire extinguishers. The main object in this fire safety training solution (Figure 4) is to develop the player's initial fire safety skills. The manuscript of this learning episode is as follows: “The environment is a simple room with a metal cabinet. The player comes in and sees the electric cabinet on fire. He or she should choose the most appropriate extinguishing method for the situation. The options include a fire blanket, a membrane foam fire extinguisher, a fire hose, and a CO2 fire extinguisher. The player should be able to choose a CO2 fire extinguisher

designed for electrical, gas and oil burns. The fire is initially inside the electrical cabinet and only smoke is visible to the hallway where the player is. Later, a larger flame will also appear.

Figure 4. The application is monitoring player's behavior and the feedback is shown at the end of the training.



After selecting the CO2 fire extinguisher, releasing the pin and opening the door, the smoke floats in the air and also player's face gets smoke. The player has to approach the burning object in the pile and stay on his knees during the shutdown. The player should be able to point the nozzle to the root of the flames and the trigger handle must be able to be pressed. Our training solution is tracking and tracing the player's behavior during the game. The player should be able to pick up the correct tool. Extra score will be given if extinguishing the flames in the time limit. The player should remove the pin before going in. In addition, the player should press the fire alarm, and close the door at the end. The player will be given penalty score for standing in the smoke or if going too close to the fire. All this feedback is visualized for the player at the end of the learning episode. If needed the player is able to start all over again to make enough repetitions for the correct actions. The duration of this learning episode is around 10 minutes and application contains minimal textual information which can be translated easily for different nationalities.

This application is developed in Finland and has received promising feedback from the technology industry. Therefore we decided to test this application in a different cultural context in Oman. The application has been tested with 16 trainees in National Training Center (NTI) in Muscat. The preliminary results (Figure 5) in this small scale experiment below shows that we received quite promising results. Trainees felt that they were able to learn, and understand fire safety issues. In addition, it seems that they would prefer to use virtual rather than traditional training methods.

Figure 5. Results of the user experience and user satisfaction questionnaire.

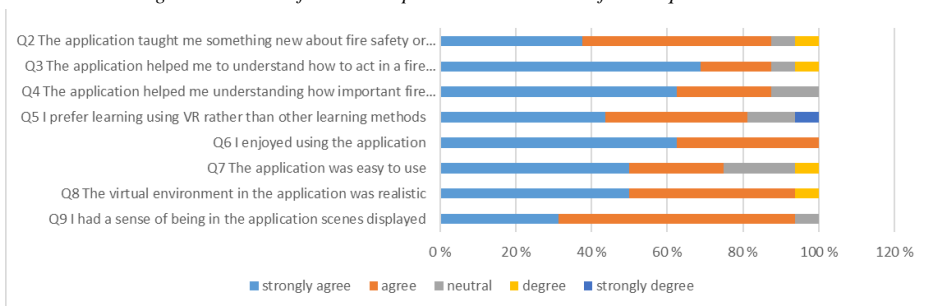

## **References**

- United Nations (2018) 68% of the world population projected to live in urban areas by 2050, says UN”, DOI = <https://www.un.org/development/desa/en/news/population/2018-revision-of-world-urbanization-prospects.html>
- Markopoulos, E., Lauronen, J., Luimula, M., Lehto, P., and Laukkanen, S. (2019) Maritime Safety Education with VR Technology (MarSEVR), In: Proceedings of the 9th IEEE Conference on Cognitive Infocommunications (accepted)
- Luimula, M., Besz, A., Pitkäkangas, P., Suominen, T., Smed, J., Izullah, F.R., and Hämäläinen, H. (2015) Virtual Evaluation Tool in Driving Inspection and Training, In: Proceedings of the 5th IEEE Conference on Cognitive Infocommunications, Gyor, Hungary, pp. 57-60.
- Hämäläinen, H., Izullah, F.R., Koivisto, M., Takio, F., and Luimula, M. (2018) The Right-side Perceptual Bias in Aging Determined in a Laboratory and during a Virtual Driving Task, *Scandinavian Journal of Psychology*, Vol. 59, pp. 32–40.
- Oliva, D., Somerkoski, B., Tarkkanen, K., Lehto, A., and Luimula, M. (2019) Virtual Reality as a Communication Tool for Fire Safety – Experiences from the VirPa Project, In: Proceeding of the 2<sup>nd</sup> Gamifin Conference, Levi, Finland, pp. 241-252.