

Product Design Innovation Major Design Project: Reducing stress during vaccination in children

HONOURS DEGREE PROJECT

SERGIO SUANZES MAZON
IT CARLOW
Design CORE

Table of Contents

1.0 Executive Summary	2
2.0 Needle Phobia	4
2.1 Context	5
2.2 The Users.....	5
2.3 Research	6
2.3.1 Methodology	7
2.3.2 Desk Research.....	7
2.3.3 Field Research	7
2.4 Design Approach	11
2.5 Sources.....	10
2.5.1 Analysis of Results.....	11
2.5.2 Hypothesis and Key Findings.....	12
3.0 Documentation	13
3.1 Project Management Plan	13
3.1.1 Project Plan Executive Summary	13
3.1.2 Project Scope Management Plan	16
3.1.3 Schedule Management Plan	18
3.1.4 Cost Management Plan.....	18
3.1.5 Resource and Project Governance Management Plan	19
3.1.6 Quality Management Plan.....	21
3.1.7 Communication Management Plan	22
3.1.8 Risk Management Plan.....	23
3.1.9 Process Improvement Plan.....	25
3.2 Design Guidelines	26
3.2.1 Universal Design Principles.....	26
3.2.2 Proof of Concept.....	29
3.2.2 The Product will... ..	26
3.2.3 Refining	29

3.2.4 The Product will not.....	27
3.2.5 User Considerations	27
3.3 Process	28
3.3.1 Project Direction	28
3.4 Business	29
3.4.1 Market Analysis.....	29
3.4.2 Competitive Advantage.....	30
4.0 Design Proposal: Anivac.....	32
4.1 How can it be used?.....	33
4.2 Universal Design Principles.....	34
4.3 Details and Specifications	35
4.3.1 Plastic Cover	35
4.3.2 0.5 mL Capsule	35
4.3.3 Toy	36
4.4 Mapping	36
4.5 Ergonomic Considerations	37
4.6 Presentation Banner.....	37

Table of Figures

Fig. 1 The users and their involvement in the vaccination process	4
Fig.2 Children Space on a Waiting Room	6
Fig. 3 Crazy Wall	9
Fig. 4 Process	26
Fig. 5 Final Design Proposal	30
Fig. 6 Exploded View	33
Fig. 7 Capsule	33
Fig. 8 Toy Selection	34
Fig. 9 Mapping Examples.....	34
Fig.10 Comparison between test models and real products.....	35

1.0 Executive Summary

To reduce the prevalence and consequences of needle phobia and needle fear in the adult population, a product has been developed. This innovative product will address the problem at its root; stressful medical procedures involving needles during a young age. Following a thorough research and test methodology, our design team has finally found a viable, economic, and feasible way of tackling this problem. The Anivac is a groundbreaking new syringe that can act as a toy and a medical device and shapes the vaccination process into a fun activity by educating and exposing children to vaccination in an interactive and playful way.

Transforming a scary and stressful experience into a pleasant and entertaining event through design is something that requires thought, empathy, creativity, a deep understanding of the user and vision. It is a challenging endeavor that has been made possible in the figure of the **Anivac**.

Needle phobia is a serious medical condition that affects approximately the 10% of the adult population. The people affected by this condition tend to avoid medical environments and refuse to take part in any kind of needle-related procedure. This leads to terrible repercussions to their well-being and health in the long run, due to the reliance of modern medicine in needles. Simple procedures like blood-testing or vaccination become dreading experiences for people afflicted by needle phobia. This condition usually stems from a traumatic event during childhood (3 to 10 years old) that is related to needles. Vaccination, being the most common painful needle procedure in children, is the most common source of these traumatic events.

Anivac is a revolutionary method that makes the vaccination process easier for children. It is composed by 2 primary elements. The first one is a medical plastic syringe that is loaded with a capsule that contains the medicine. This syringe has a childish, toy-like appearance that is non-threatening to children. It is equipped with a plastic needle cover that hides the needle and acts as a support for a little animal toy. This toy is meant to distract the child and serve as a gift later. The second element is a toy replica of the medical syringe. This toy replica can be picked up by the parents before the injection and brought home for the child. At this moment, the staff of the clinic can give the parents some advice and tips on how to behave during the vaccination. At home, the child can use the toy to experience and discover the vaccination

process in a safe and relaxing environment through games. The replica can also be brought to the consult and act as additional distraction for the child. These two elements complement each other and work to make the vaccination process a positive, fun and engaging experience that children will expect, and not dread.

40% of the Irish choose private healthcare over public healthcare, but this number is lower as the years pass. As this number declines every year, it has become a necessity for private clinics and hospitals to start offering more value at the same or reduced price to their customers. The Anivac creates value for these private medical providers at reduced cost. The product meets the VRIN criteria for creating competitive advantage. It is valuable as it addresses a widespread and persistent problem, and makes the lives of healthcare professionals, parents, and children less stressful. The product is rare because it is the first of its kind and the concept can be patented for added protection of its rarity. The product is inimitable because of the unique product and company focus; to address a specific issue – needle phobia – in a specific population – children. Finally, the product is non-substitutable as no other product or service has ever been developed to target the specific problem focused on by Anivac.

2.0 Needle Phobia

2.1 Context

Needle phobia is a severe medical condition that affects the lives of at least 10% of the population (Hamilton J. 1995). It is identified by a severe distress at the prospect of needle exposure and the avoidance of medical care to eliminate the possibility of exposure to needles (Sokolowski C. *et al* 2010). Modern medicine relies in several needle procedures so needle phobia is becoming an increasingly important issue due to the affected avoidance of medical environments (Hamilton J. 1995). Because of this once it develops the diagnosis and treatment of needle phobia is not easy (Orenius T. *et al* 2018). The development of methods to fight this condition is one of the greatest challenges that needle phobia presents (Hamilton J. 1995).

But what if it is fought before it appears? Needle phobia normally develops in children between 4 and 10 years old (McMurtry M. *et al* 2015) triggered by a stressful or traumatic puncture (Sokolowski C. *et al* 2010). The most common needle procedure in young children is vaccination. About half of children suffer major distress during vaccination and most of them show some sign of distress or fear. This process causes and unnecessary suffering to children (Cohen L. *et al* 2002) that should be prevented. Making sure that vaccination is a positive experience involves the implication of parents and medical personnel as these groups are the ones that impact the experience of children the most (Cohen L. *et al* 2002).

2.2 The Users

In this problem area three primary users have been found. The first one is the children that are starting to receive vaccination. Their age ranges from 4 to 8 years and they are from every background and gender. The second one is the parents and legal guardians of the children that get vaccination. They are young adults that are dealing with the first vaccination and medical procedures of their children. The last one is the medical personnel that are involved in the vaccination process.

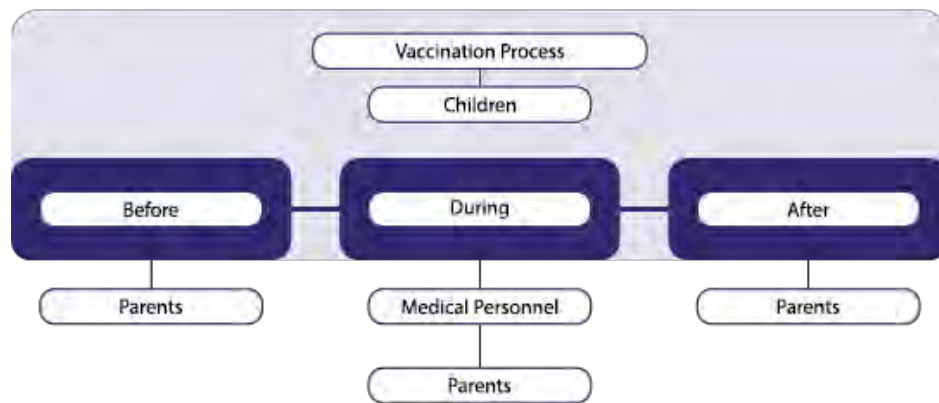

Fig. 1 The users and their involvement in the vaccination process

Groups that can benefit from this project can be considered tertiary users. They can range from teachers and nurses during school's vaccinations in the future and medical personnel that have to work with needles and benefit from a reduced fear of this procedures to even people waiting for blood donations, as the reduced apprehension of needles may increase the donation pool.

2.3 Research

2.3.1 Methodology

For the research of this project a qualitative approach was used. The reason behind this decision is that this project is centred in the experience and emotions of the user when they undergo a determined process. This means that obtaining information about their needs, actions and feelings that are involved in the problem is essential and must be recorded with the upmost detail. To this end, open-answer surveys and semi-structured interviews were used.

An in-depth desk research was also employed with the purpose of getting an initial knowledge of the problem. This desk research proved useful to obtain quantitative information about the prevalence and consequences of the problem as well as backing up the theories that came from the field research investigation.

2.3.2 Desk Research

- Across the lifespan, individuals report an absolute increase of approximately 10% in willingness to be vaccinated if the delivery were painless (McMurtry M. *et al* 2015).
- "Routine" procedures such as immunizations and venepuncture continue to cause unnecessary suffering for children (Cohen L. *et al* 2002).
- Needle procedure-related fear may result in increased avoidance behaviour and attempts to eliminate any possible exposure to needles (Sokolowski C. *et al* 2010).
- Research indicates very minimal instruction leads to parents effectively reducing their own anxiety and serving as excellent coaches for their children (Cohen L. *et al* 1997).
- Numerous studies have shown that patients with needle phobia have family members with similar traits (Hamilton J. 1995).
- Repeated role-playing prior to the procedure and reinforcement for using the skills during the procedure might have increased children's independent coping (Cohen L. *et al* 2002).
- Increased coping skills and natural desensitization through repeated exposure to needle experiences might be influential factors (for the reduction of needle fear) (Orenius T. *et al* 2018).

2.3.3 Field Research

The research started with the preparation of an open-answer survey that was delivered to nursery students that have done intern-ships in paediatrics and have experience dealing with children during needle procedures. The intent of the survey was to obtain a general view of the problem from the perspective of the medical personnel.

The survey provided initial view into the realities of the problem and the behaviours of the users. Out of 3 clinics only 1 used distraction during vaccination, other relied in giving information about the procedure to the children and the last one did not use any kind of stress relief tactic. All 3 stated that most children present signs of stress or discomfort since they come in the consult and that the most stressful moment was just before the puncture. The 3 participants also highlighted the importance of the parent's role during vaccination and the positive effects they have on the children. The information obtained during the survey served as the basis of where the rest of the research would be focused.

The next step was doing interviews and observing the environment of the problem. For this, 6 clinics were visited. As the survey revealed that most children were showing stress before entering the consult, the conditions of the waiting rooms were of interest. The 6 waiting rooms had a very similar look and ambient. Only one of them had some form of entertainment for the children and not even one had a separate room for them.



Fig.2 Children Space on a Waiting Room

Only one clinic allowed for an interview that proved highly useful in defining the final direction of the project. In this clinic a doctor that worked primarily with travel vaccines was interviewed.

He stated that the first thing he does is tell children what is going to happen and that the procedure hurts. This was, he says, they can correctly manage the feelings that come from the vaccination. In his opinion the fear of needles comes from disinformation and bad practices of the parents during and before the process. Children with positive parent influence are easier to manage. He also said that he would never vaccinate children without their parents present. In his opinion is important that children are correctly informed about vaccines, but it is even more important that the parents are, as they can be very helpful to the positive experience of the child during the process or the complete opposite.

He also explained how managed the process and the methods he uses to make the experience as pleasant as possible. His preferred method consists of motor distraction, by keeping the child focused in moving other parts of his body he shifted the attention from the puncture, and the delivery was almost non-noticeable.

Finally, he explained that a reward system is counterproductive as this reinforces the idea that vaccination is a bad experience and going through it a difficulty when the reality is different. He said that he is not opposed to the idea of trying different products that could make children vaccination easier.

- Only one third of the clinics employ distraction techniques during children vaccination.
- All 3 reported that children show signs of stress during vaccination.
- The most stressful moment is just before the injection.
- Parents play a significant role in children vaccination.
- Out of 6 visited clinics, only one had children focused entertainment in the waiting room.
- The same waiting room was used for both adults and children.
- Is important to understand that the fear of needles does not come from the needle itself.
- A positive parent influence is very helpful in reducing stress.
- A “reward” system can be counterproductive, as it can reinforce the notion that vaccination is a bad thing.

- Distraction is a powerful tool to reduce stress.
- Doctors are open to the use of products that may reduce stress.

2.4 Sources

- J CC. Meghan McMurtry, Rebecca Pilloi Riddell, Anna Taddio, Nicole Racine *et al*: *Far From "just a Poke": Common Painful Needle Procedures and the Development of Needle Fear 2015*
- Chester J. Sokolowski, Joseph A. Giovannitti Jr, Sean G. Boynes *Needle Phobia: Etiology, Adverse Consequences, and Patient Management 2010*
- James G. Hamilton *Needle Phobia: A Neglected Diagnosis 1995*
- Cohen L. L., Bernard R. S., Greco LA., McClellan C. 8. (2002) *A child focused intervention for coping with procedural pain: Are parent and nurse coaches necessary?*
- Cohen, L. L., Blount, R. L, & Panopoulos, G. (1997). *Nurse coaching and cartoon distraction: An effective and practical intervention to reduce child, parent, and nurse distress during immunizations.*
- Tage Orenius, Hanno Saita, Katriina Mikola, and Leena Ristolainen (2018) *Fear of Injections and Needle Phobia Among Children and Adolescents: Overview of Psychological, Behavioural, and Contextual/ Factors.*
- C. Meghan McMurtry, PhD, C Psych, Melanie Noel. PhD, {...]. and HELPinKids&Adults Team (2015) *Intervention for individuals with High Levels of Needle Fear: Systematic Review of Randomized Controlled Trials and Quasi-Randomized Controlled Trials*

2.4 Design Approach

2.4.1 Analysis of Results

As the information was being gathered, it was being organized in different areas depending of the relation between the information and the problem. These areas were context of the problem, consequences and solutions. A **crazy wall** was built to get a visual rep-resentation of the problem and the information gathered.

Then the information was divided further, in more specialised areas, to obtain a more accurate view of the factors that influence the problem. The first of these areas was **needle phobia**, the starting point of the research, and developed to **vaccination in children**, the problem that is being solved.

From there more areas were placed. These areas were **consequences**, **stress factors** and **prevention methods**. Then the information was linked to obtain a first view of the key points and the gaps in the research.

After the gaps in the research were identified (interaction with the users and their role in the problem) more field research was done and added to the wall.

With this new field research, that revealed the importance of information and parent intervention during the vaccination process, the final direction and key points of the project became clear.

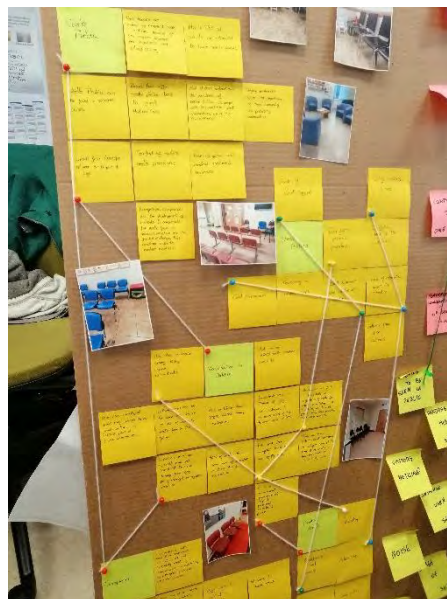

Fig. 3 Crazy Wall

2.4.2 Hypothesis and Key Findings

"It should be possible to design a product that reduces stress during vaccination in children"

- The fear of needles is more related to the state of mind of the children during vaccination than to the pain are the needles themselves, so it is valuable to change the perspective of children regarding vaccination.
- Children that are informed and exposed to the process show less stress and fear. Is important to deliver the information and the exposure in a safe, engaging
- Children are always vaccinated with their parents present so it is important that they also feel relaxed and calm because the parent attitude can impact the child's.
- Parents should be educated about the process and how they can positively impact the vaccination experience of their children.

3.0 Documentation

3.1 Project Management Plan

3.1.1 Project Plan Executive Summary

Introduction

The project undertaken will be a product that makes the vaccination process easier for children and parents by exposing them to the process in advance in an engaging and fun way. The purpose of the project is to battle the expansion of needle phobia and needle related fear. This problem is rarely addressed, and it has become increasingly problematic as modern medicine relies on needle puncture procedures like blood testing and vaccination.

This problem has been largely ignored so the opportunities to develop a new product are large. The market scope is big as both clinics and parents can be targets. As per the research done, both areas are willing to purchase and try different methods that make vaccination easier. This problem area has not been explored from this angle, so competition is scarce and mostly limited to medical equipment with the constraints and regulations that that area has.

The project is set to provide a solution to a rarely addressed problem from a new perspective. This gives the project a distinct standing on the market and gives it an edge over the competition. This also has its downsides as being the first to enter the market means that no opinion of the product has been formed yet and there is not consumer trust. Therefore, guaranteeing the effectiveness with a solid research plan is going to be of great importance.

Background

This project originates from the need to fight needle phobia. Needle phobia is a severe medical condition that affects the lives of at least 10% of the population. It is identified by a severe distress at the prospect of needle exposure and the avoidance of medical care to eliminate the possibility of exposure to needles. Modern medicine relies in several needle procedures so needle phobia is becoming an increasingly important issue. due to the affected avoidance of medical environments. Because of this once it develops the diagnosis and treatment of needle phobia is not easy. The development of methods to fight this condition is one of the greatest challenges that needle phobia presents.

But what if it is fought before it appears? Needle phobia normally develops in children between 4 and 10 years old triggered by a stressful or traumatic puncture. The most common

needle procedure in young children is vaccination. About half of children suffer major distress during vaccination and most of them show some sign of distress or fear. This process causes an unnecessary suffering to children that should be prevented. Making sure that vaccination is a positive experience involves the implication of parents and medical personnel as these groups are the ones that impact the experience of the children the most.

In this project the research done has provided the methods to develop a product that can fight this problem in an effective way. This product is being developed for the Design Department of the Institute of Technology Carlow as part of the Honours Degree Project realized during the final year of the Product Design Innovation module.

Rationale and Expected Benefits

This project is expected to impact the lives of several distinct demographics both directly and indirectly. The first group of benefited stakeholders are the young children that undergo their first vaccinations. Thanks to the product they will be able to go through this process painlessly and free of stress and fear. This in turn eases the work of the medical care personnel that must deal with problem behaviour in the clinic. The adult population with children will also benefit. More than 60% of the adult population claims to have some level of fear of needles, this project will alleviate those fears in parents as they get exposed to the process in a safe environment and go through it in company of their children.

In the long term the people that benefit from the project increases, as the children that are helped interact with new puncture processes and medical environments. Correct vaccination helps with group immunization and it may increase blood donations, as populations grow less wary of needle procedures.

Is important that the project is developed now as the results are highly beneficial and no other companies are developing a similar product. Being the first ones to get results will positively impact the developers' image and lead to future benefits.

Anticipated Issues

Several factors that may impact the project and planning progress have been identified and divided in Macro Issues and Micro Issues. Identifying these issues ahead of time allows to develop a project plan that will not be severely hindered by them and leads to a correct progress of the project development.

Macro	Language
	Work Culture
	Academic System
	Number of Projects
Micro	Lack of contacts
	Formal Writing
	Field Research Unpredictability
	No Workshop experience
	Equipment
	Mobility

3.1.2 Project Scope Management Plan

Scope

This project aims to provide a solution to the proliferation of needle phobia in the adult population by addressing the factors that contribute to it before it even appears. This involves working with children and young/first time parents to make the vaccination process easier as it is the most common painful needle procedure.

Key Objectives	Mitigate the proliferation of needle phobia
	Expose children and parents to the process in a safe environment
	Inform parents about their role in the vaccination and correct behaviour
	Make parents and children work and learn together
	Create a system that allows this to be fun and engaging
	Transform vaccination from a chore and a hardship to a smooth and normal experience

Authorisation of Scope Changes

Governance Entity	↑Functional Specification or Omission		↓Functional Specifications
	Total Contingency	Individual Allocation	
Project Manager	10% of Total	≤1% of Total	None
Project Sponsor	20% of Total	≤5% of Total	≤2.5%
Project Steering Committee		5 - 10%	All other
VC		Any spend above contingency but within delegations	
Council		Any spend above contingency	

Project Plan

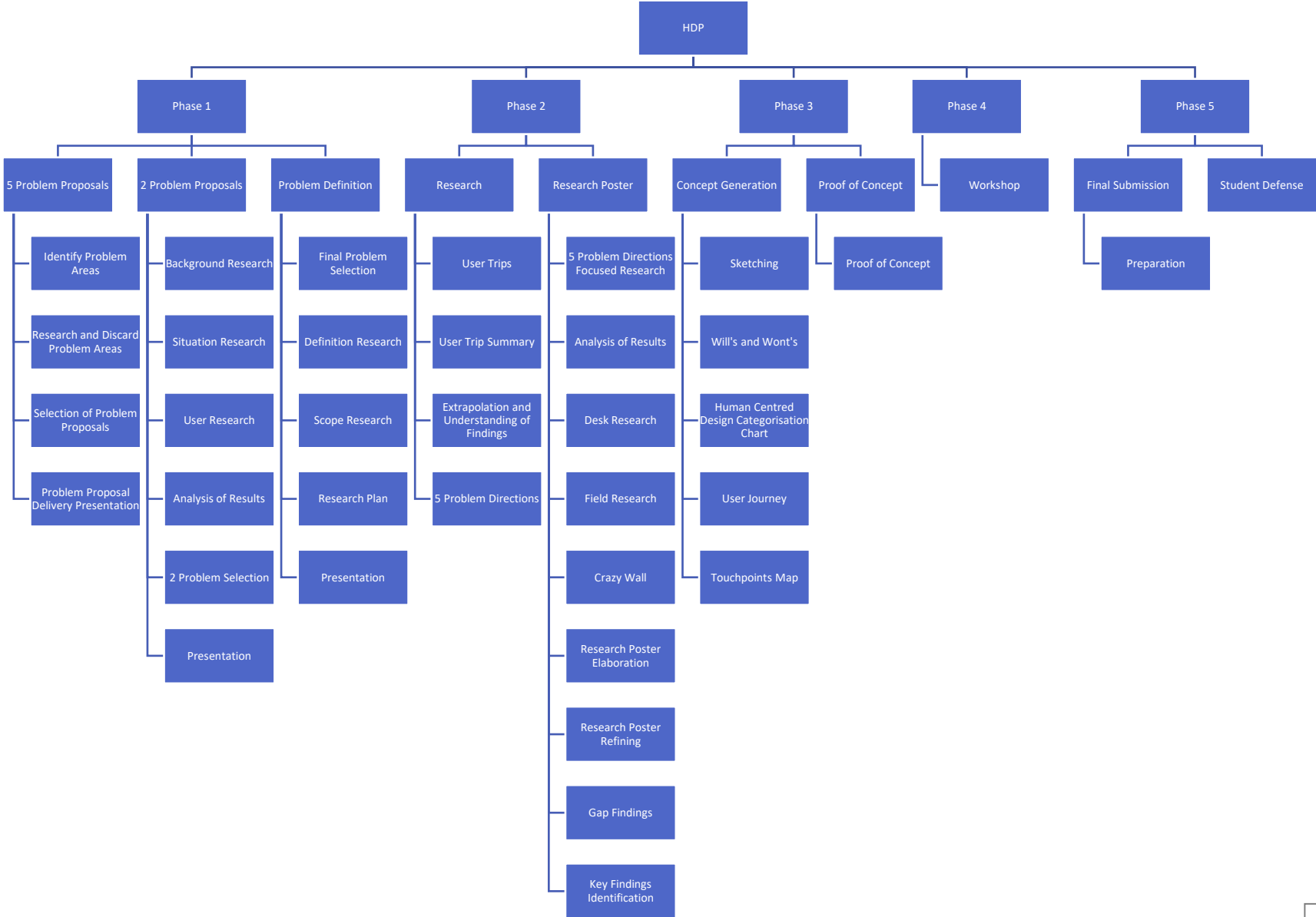

3.1.3 Schedule Management Plan

See Annex 1 and Annex 2

3.1.4 Cost Management Plan

Cost Breakdown

Item/Service	Unit(s)/Time	Hr./Rate/Value	Total Estimated (€)
Capital Costs			
Space & Facility	9	440.00 € / month	3,960.00 €
Equipment	-	-	120.00 €
Other	-		00.00 €
Ongoing current costs			
Project Management	9	4,583.00 € / month	41,249.99 €
Research	4	5,269.16 € / month	21,076.64 €
Design	9	3,750.33 € / month	33,750.00 €
Modelling	2	2,708.33 € / month	4,708.33 €
Other	-		00.00 €
Total Estimate Expenditure:			104,864.96 €

Estimate for a 9-month project window

3.1.5 Resource and Project Governance Management Plan

Project Team + Project Deliverables

Several individuals are involved in the correct development and consecution of this project. The individual in charge of the work of each aspect of the project development is *Sergio Suanzes* and the rest of the individuals oversee revision and quality control.

Research	Sergio Suanzes	Bernadette Douglas
	Hilary Dempsey S.O.	Brian Casey
Planning	Sergio Suanzes	
	Collin Deevy S.O.	
Design	Sergio Suanzes	Emmet Sexton
	Hilary Dempsey S.O.	PJ White
Modelling	Sergio Suanzes	
	Hilary Dempsey S.O.	Bryan Leech
Sketching	Sergio Suanzes	
	Bryan Leech S.O.	

Deliverable	Method	Sign-Off	Planned Date
5 Problem Proposals	Written Report	Hilary Dempsey	18/09/19
2 Problem Proposals	Presentation	Hilary Dempsey	02/10/19
Problem Definition	Presentation	Hilary Dempsey	09/10/19
User Trip Summary	Written Report	Hilary Dempsey	16/10/19
Reflection Report	Written Report	Hilary Dempsey	16/10/19
HDP 5 Directions	Presentation	Hilary Dempsey	23/10/19
Research Poster	Presentation	Hilary Dempsey	27/11/19
HDP Concept Criteria		Hilary Dempsey	09/01/20
HDP Concepts		Hilary Dempsey	22/01/20
Proof of Concept		Hilary Dempsey	04/03/20
Final Submission	Written Report	Hilary Dempsey	06/05/20
Student Defense	Presentation	Hilary Dempsey	07/05/20

Control Mechanisms

Tolerances

Objective	Control	Permitted Variance
Problem Definition - October 9th	Time	+/- 3 days
Desk Research - September 20th	Time	Completion 3 days prior
Field Research – September 27th	Time	Completion 5 days prior
-	-	-

Proposed Project Governance

Title	Person/s (Title and Name)
Project Sponsor	IT Carlow, Design Department
Project Steering Committee	Hilary Dempsey Dr. PJ White Emmet Sexton Brian Casey
Project Manager	Sergio Suanzes Mazon
Project User Group	List all members
Project Working Group	Sergio Suanzes Mazon
External Oversight	

Monitoring and Reporting

Control	Purpose	Frequency
Project Status Report	Submitted to Project Sponsor to report on project status & progress.	Weekly
Exception Report	Produced for Project Steering Committee (or Project Sponsor) when project is in danger of exceeding planning tolerances	As required
End Stage Report	Produced for the Project Sponsor to summarise events & achievements of current stage	At the dates set
Scope	Changes to scope are reported to the Project Steering Committee or Project Sponsor for approval	As required
Quality	Project products should meet quality expectations. A report to the Project Sponsor will be made should products fail to meet ITR or business standards or where quality control measures have not been followed	As required
Issue Log, Risk Register	Tool for registering & managing risks, issues & informal problems &/or concerns relating to the project	Updated as required

3.1.6 Quality Management Plan

Project Approach and Options Considered

For the research of this project a qualitative approach was used. The reason behind this decision is that this project is centred in the experience and emotions of the user during a certain process. This means that obtaining information about their needs, actions and feelings involved in the problem in the most detailed way possible. To this end, open-answer surveys and semi-structured interviews were used.

An in-depth desk research was also employed with the purpose of getting an initial knowledge of the problem. This desk research proved useful to obtain quantitative information about the prevalence and consequences of the problem as well as backing up the theories that come from the field research investigation.

Planning Assumptions

In the research stage weekly meetings are scheduled to review the quality and quantity of the sources employed and the data obtained. Before each of these meetings progress in the definition and direction of the project must be reviewed and assessed. If the review is negative further work must be done to make up for the delay and correction of the errors.

For the conceptualization stage meetings will be further apart. In this stage the quality and quantity of the concepts presented will be reviewed. Negative feedback must be addressed.

3.1.7 Communication Management Plan

Communication & Consultation

Communication with the supervisors of the project will be undertaken on a weekly basis to check the correct development of the project. This weekly communication will be made in an informal meeting where the process and stage of the project will be shown to the supervisor for feedback. Formal meetings are scheduled with varied frequency. In these meetings the supervisors will review the direction the project is taken and offer advice.

In case of an eventuality the supervisors may be contacted via e-mail. If further action is needed an appointment may be scheduled to solve the problem. In the event of delay in the project the supervisor should be contacted in advance, either via e-mail or during one of the weekly meetings.

At the end of the development process the final state of the project will be presented via exposition to the stakeholders. In this meeting they will review the project and the expectations of the stakeholder should be met.

3.1.8 Risk Management Plan

Key Risks

Scope	Scope is badly defined
	Activities are missing
	Dependencies are inaccurate
Cost Management	Inaccurate
Communication	Misunderstood requirements
	Under communication
Resources and Team	Resource shortfall
	Negative attitudes
	Ill attitude towards the project
	Inexperience
Decisions	Delays
	Ambiguous
	Incomplete
Project Management	Failure to follow the plan
	Errors in management process
	Lack of management control

To mitigate these risks a correct project management plan is needed. The project plan should cover all the risk areas and specify the steps that must be taken to a successful project development. It is also important to follow the plan, as not doing it will increase the risks and make the effort that a good project plan requires useless.

Key Dependencies

Deliverable	Dependency	Risk	Risk Management
5 Problem Proposals	Research	Late decision making	Engage research early
2 Problem Proposals	5 problem proposals	Poor problem choices	Select problems that work well with the project objectives
Problem Definition	2 problem proposals	Late decision on the chosen problem	Do good research and compare problems extensively
User Trip Summary	Problem Definition	Bad problem definition	Extensive research and correctly identify the users
Reflection Report	All the above	Unfinished steps	Go through the process with the appropriate timing
HDP 5 Directions	Field and desk research	Uncertainty	Do an in-depth research and understand the users
Research Poster	Research	Lack of hypothesis	Appropriate field research and in-depth desk research, understanding the user needs
HDP Concept Criteria	Research Hypothesis and Key Findings	Lack of clear direction	Correctly analyse the information gathered
HDP Concepts			
Proof of Concept			
Final Submission			
Student Defense			

3.1.9 Process Improvement Plan

High Level Timeline

Project Name: Honours Degree Project	Project Manager: Sergio Suanzes Mazon	Date Prepared:
--------------------------------------	---------------------------------------	----------------

Phase, activity, task Description	Person Response.	Work effort	Timeline																			
5 Problem Proposals	Sergio S.		C+1																			
2 Problem Proposals	Sergio S.				C																	
Problem Definition	Sergio S.					C																
User Trip Summary	Sergio S.						C-5															
Reflection Report	Sergio S.						C															
HDP 5 Directions	Sergio S.							C-2														
Research Poster	Sergio S.								C													
HDP Concept Criteria	Sergio S.																					
HDP Concepts	Sergio S.																					
Proof of Concept	Sergio S.																					
Final Submission	Sergio S.																					
Student Defense	Sergio S.																					
Original planned end date will be met			+/- (n) task now (n) weeks ahead or behind schedule										C=task completed this week									

3.2 Design Guidelines

3.2.1 Universal Design Principles

- Principle 1: **Equitable Use**, the design is useful and marketable to people with diverse abilities.
- Principle 2: **Flexibility in Use**, the design accommodates a wide range of individual preferences and abilities.
- Principle 3: **Simple and Intuitive Use**, use of the design is easy to understand, regardless of the user's experience, knowledge, language skills, or current concentration level
- Principle 4: **Perceptible Information**, the design communicates necessary information effectively to the user, regardless of ambient conditions or the user's sensory abilities.
- Principle 5: **Tolerance for Error**, the design minimizes hazards and the adverse consequences of accidental or unintended actions.
- Principle 6: **Low Physical Effort**, the design can be used efficiently and comfortably and with a minimum of fatigue.
- Principle 7: **Size and Space for Approach and Use**, appropriate size and space is provided for approach, reach, manipulation, and use regardless of user's body size, posture, or mobility.

3.2.2 The Product will...

- Expose children to the vaccination process.
- Be fun, engaging and interactive.
- Incentivise the involvement of parents or tutors
- Educate
- Be manageable (Appropriate size)
- Be Age appropriate
- Be easy to use
- Aid doctors on their labour
- Be easy to store

3.2.3 The Product will not...

- Be dangerous
- Require intense physical activity
- Be mentally draining
- Be a complete replacement to other stress-reducing methods
- Require a complex set-up
- Require any training
- Only involve children

3.2.3 User Considerations

Colour

- In the development of this product the challenge is to pick colours that can both give a clean medical look, without being uninteresting and boring to children.
- To this end a Complementary or Split-complementary seem the most adequate colour schemes, in order to draw the children attention certain parts of the product.

Mapping

- The goal on the product mapping was to keep the product as easy to use as possible and minimizing the mistake possibilities.
- The major objective was to not increase the doctor chores and make the product ergonomics close to those of a traditional syringe.

Ergonomic Considerations

- Doctor
 - Keep the product simple
 - No need to learn new techniques or complicated functions
 - No additional preparation required
- Child
 - *Easy to relate to*
 - *Interesting*
 - *Safe*
 - *Engaging*

3.3 Process

3.3.1 Project Direction

First different problem areas that were suitable for the project were identified. Once a potential problem proposal was found, an initial research was done to identify product potential in that area. This method was used to come up with 5 different problem proposals. From these 5 problems 2 were chosen to continue forward. A more focused research was made about these 2 problems areas. Then they were compared using a screening matrix that lead to the final problem proposal. This problem proposal was defined after more research. With the problem fully defined, the scope of the project opened again with the 5 directions that were identified during the field research. Then the narrowing process started again, leading to the final ideas presented in the research poster.

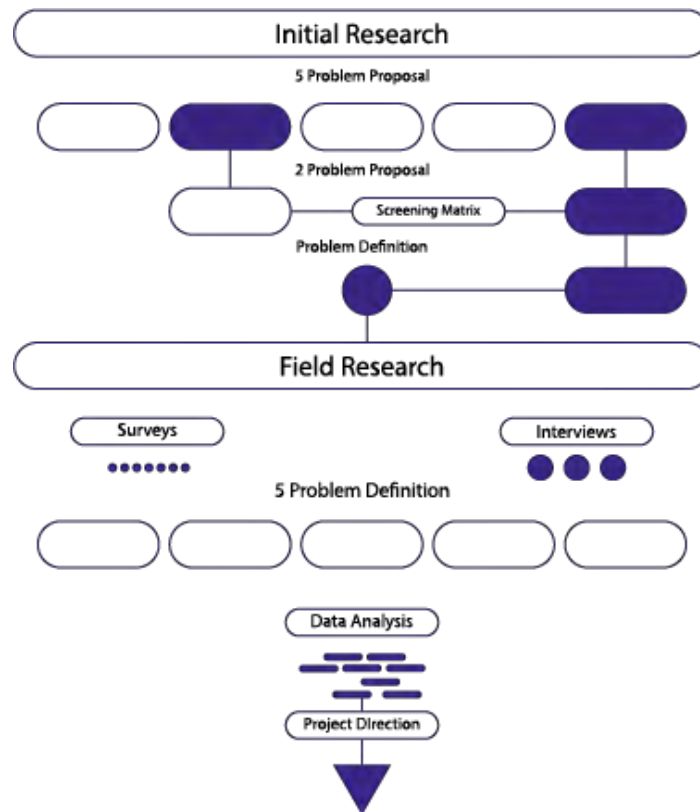

Fig. 4 Process

3.2.2 Proof of Concept

See Annex 3

3.2.3 Refining

See Annex 4

3.4 Business

3.4.1 Market Analysis

Target Market

- **Private Healthcare Clinics and Hospitals**
 - **Size of the market segment:** There are 4 big private healthcare providers on Ireland. There are 18 hospitals on the Private Hospital Association, the biggest concentration of those are on the Dublin area. These are one third of the hospitals on Ireland.
 - **Is the segment growing or declining?** A 2019 study shows that private clinics and hospitals are becoming more prevalent and growing, soon to overtake public facilities in numbers.
 - **Characteristics:** Long standing and visible commitment to patient safety and quality of care. Patient safety and quality. Needs to offer additional value to customers, in order to stand out over others and over public healthcare. High service standard.
- **Parents**
 - **Size of the market segment:** At least 40% of the Irish choose private healthcare plans over public healthcare, one of the biggest percentages in Europe
 - **Is the segment growing or declining?** The number of Irish subscribed to a private healthcare plan is slowly declining to the increase in prices.
 - **Characteristics:** Invested in their child wellbeing, looking for the best medical plans now that is starting a new family. Might be oblivious to the problem but will do research in order to obtain the best insurance possible.

Market Trends

Due to the actual global situation, is expected that individuals will be more concerned with their healthcare plans more than ever. Vaccines will rise even more in importance and the problem associated with them too. More people will become aware of the opportunities that vaccination provides in product development and the demand will rise.

3.4.2 Competitive Advantage

The product offers unique value to various segments of the market. The first beneficiary of the value of the product are the private health insurance companies. This product lets them appeal to new parents by offering a solution to the common and widely known problem needle phobia for their child's. This solution allows them to differentiate from other insurance providers and supports the price increase over public healthcare. Independent private clinics can also benefit from this, and they can create a local reputation based on patient care and user experience investment. The final beneficiaries are the parents themselves, whose children will grow up less afraid of needles, medical processes, and medical workers.

This all ties together for the final benefit of the product, loyalty. The children become accustomed to a unique way of medical procedure, only supplied by our costumer, this makes parents going to another provider more unlikely. Also, putting a focus on user experience results in happier and loyal customers.

The product offers several sources of competitive advantage for the company. First, no other product like Anivac exists on the market. Additionally, the product meets the VRIN criteria for creating competitive advantage. It is valuable as it addresses a widespread and persistent problem, and makes the lives of healthcare professionals, parents, and children less stressful. The product is rare since it is the first of its kind and the concept can be patented for added protection of its rarity. The product is inimitable because of the unique product and company focus; to address a specific issue – needle phobia – in a specific population – children.

Finally, the product is non-substitutable as no other product or service has ever been developed to target the specific problem focused on by Anivac. The advantages provided by the product can be used to pursue a differentiation focus competitive strategy. The company will address a narrow market using a unique product to create product and brand loyalty. Children will become accustomed to the unique method of vaccination provided, which can only be supplied by the product buyers. This will make it unlikely for parents to switch healthcare providers. Also, putting a focus on user experience results in happier and loyal customers.

4.0 Design Proposal: Anivac

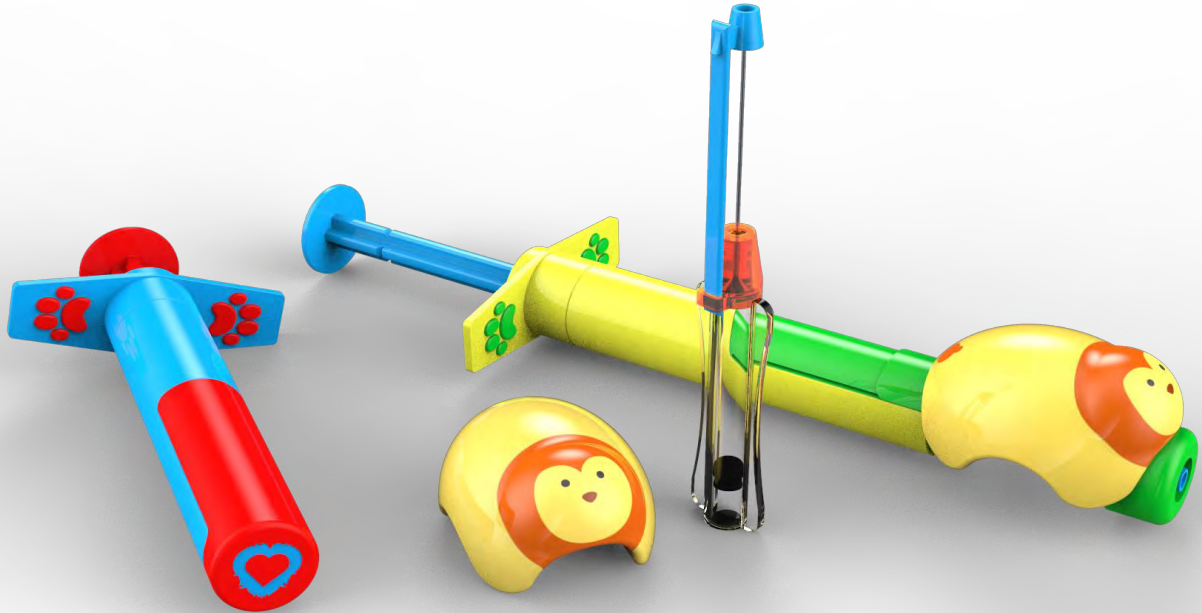

Fig. 5 Final Design Proposal

“The Anivac is a product that functions as a medical syringe for children vaccination. It’s a plastic device that can be loaded with a pre-filled 0.5mL capsule with an integrated needle. The plastic device covers the needle and hides it from the child’s sight. With the device comes a little toy that can be chosen by the child before the vaccination, and can be gifted to them after, to create an interactive and fun environment. The aim of this product is to reduce the prevalence of needle phobia, by reducing the chance of traumatic events related to needles during childhood.”

4.1 How can it be used?

Needle phobia is a serious medical condition that affects approximately the 10% of the adult population. The people affected by this condition avoid going to the doctor and general medical care to reduce the chances of getting in contact with any type of needles. This leads to terrible repercussions to their well-being and health. Needle phobia usually stems from a traumatic event involving needles at a young age and vaccination, being the most common painful needle procedure in children, is the area of focus of the product.

Anivac is a new syringe adapted to deliver young children a positive, interactive and fun experience during vaccination in order to reduce the prevalence of stressful and painful situations during vaccine delivery. It's a toy-like medical syringe, that's loaded with a pre-filled vaccine dose and has a little detachable animal toy at the top, covering the needle. This medical syringe is like a syringe toy given to the child at a moment before the puncture. With this replica, children can interact, explore and discover the medical world and the vaccine process in a zero-stress environment, with the help of their parents or tutors, which also learn. The parents emotional state during the vaccination process heavily impacts the child's perception, as demonstrated by the fact that a high number of people affected by needle phobia have a close friend or family member with a high fear of needles. Giving them another insight into how the process could be, harmless and fun, takes a burden off them and leads to them having a more positive and relaxed attitude towards vaccination, which is a positive influence on their children.

In the hospital, the product acts as a link between the child and the doctor, it establishes a sense of familiarity. The doctor is not a total stranger anymore, and the child can relate to them in a certain way, as both have the same "toy". This lets the doctor employ traditional stress reducing techniques in a more effective way. The children also interact a little with the doctors' device. Though is not recommendable that the children get to hold it or use it, he can choose the little toy on top, giving a positive feeling of decision and control during the process. This toy can be given to the child after the vaccination as a reward or present, and they can put it on their syringe toy.

This product is a method of improving an experience that all children must go through, so it was developed with the aim of being usable by all kind of children. The toy children interact with is simple and does not involve complex mechanisms, loud noises or strong lights that may affect some kids. The heart of the product is based on the interaction and experiences that the children will gain. The only limitation is their imagination.

4.2 Universal Design Principles

Principle 1: The product was made with universal usage in mind. It does not require complex motor movements, high intensity physical activity or great mental effort. The product objective is to expose children to the vaccination process and the devices involved, so they only need to interact with it in any way they can. In the given case that they cannot physically interact with it, their parents or someone close to them can use it and play with them to provide the experience.

Principle 3: The user mapping on this product has been tested and refined over several iterations in order to make its use as intuitive as possible. For this, the product has a visual and textured mark on the flanges and the plunger, to signal how and where it should be held. The medical device lid parts are color-coded to make the assembly process easier and faster. Despite its more child-like appearance, it still follows the same structure of traditional syringes and does not require additional skills or training to correctly use it.

Principle 5: The error reduction was especially important in the development of the pre-filled capsule. This capsule only fits in the device in a certain way, eliminating the possibility of introducing it wrong. It has a black mark for the doctor to check the medicine volume, which can be seen even when its loaded on the device. The capsule also presents a plastic protection on the needle tip. This protection only goes away during the puncture, and it automatically goes back on after it finishes, leaving no moment where the needle tip might be a hazard. For the integrated needle, a 25-gauge 25 millimetre one was used. This is because 25-gauge needles are considered less painful and have less risk of inflammation and discomfort.

Principle 6: The product barely requires more work from the doctors than any other syringe. Its shape and shape are similar, and it has some more previous preparation, but the physical effort required to set everything up is minimal. The toy for children only requires as much physical effort as they want to put in when they play with it. Its shape and functions are not physically extenuating or intensive at all.

Principle 7: The product is relatively small. It is slightly wider than the typical medical syringe, but it is in line with modern auto-injectors that some people need to use to puncture themselves at home. Its length is the same as normal syringes, despite the first impression it can give. This is because the needle cover gives it a bulkier aspect compared to normal syringes. Even if it may look heavy and unwieldy compared to other syringes, the cover is made of plastic and hollow. Its heavier, yes, but still manageable and comfortable.

4.3 Details and Specifications

4.3.1 Plastic Cover

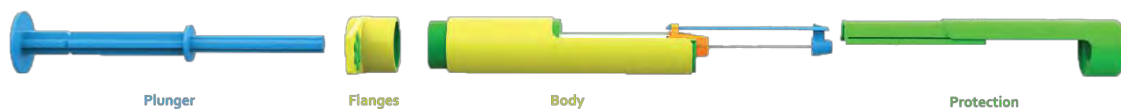

Fig. 6 Exploded View

- **Plunger:** *See Annex 5*
- **Flanges:** *See Annex 5*
- **Body:** *See Annex 5*
- **Protection:** *See Annex 5*

4.3.2 0.5 mL Capsule



Fig. 7 Capsule

- **Syringe:** *See Annex 5*
- **Plastic Cover:** *See Annex 5*
- **Needle:** 25mm Length, 25 Gauge, Stainless Steel

4.3.3 Toy



Fig. 8 Toy Selection

- **Toy:** *See Annex 5*

4.4 Mapping

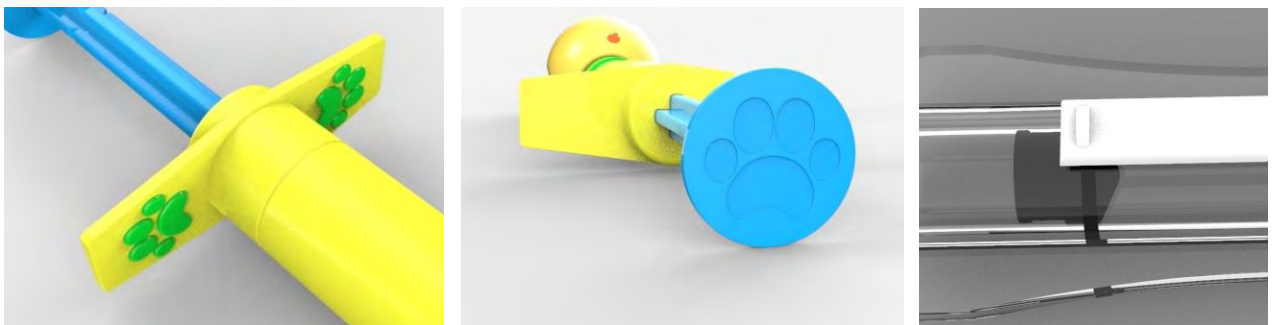

Fig. 9 Mapping Examples

- The mapping has been developed and tested with ease of use in mind.
- The paws represent through shape, texture and colour the places where one must place their fingers on the product.
- The movable and detachable parts can be identified easily through colour.
- The capsule has a black mark to check that the amount of medicine is correct.

4.5 Ergonomic Considerations



Fig.10 Comparison between test models and real products

- The product sizes have been modelled after real products that have similar functions.
- The body has been tested with a small medical syringe and a home auto-injection device.
- The capsule has been tested with a 0.5 mL capsule.
- In contrast with the auto-injection device, Anivac keeps the plunger to allow the doctor to choose at which speed the medicine will be injected.
- The capsule used in Anivac possesses a plastic cover on the needle, to reduce the chance of accidental puncture.
- This protection moves at the same time as the needle protection of the plastic device.
- The capsule can only be introduced into the device in one way, to deny the chance of setting it wrong.
- It can be easily disassembled for ease of cleaning.
- Most parts are hollow to reduce the weight.

4.6 Presentation Banner

See Annex 6

ANNEX

Sergio Suanzes Mazon
IT CARLOW Hilary Dempsey 12/05/20

Table of Contents

1.0 Annex 1	1
2.0 Annex 2	3
3.0 Annex 3	7
4.0 Annex 4	38
5.0 Annex 5	66
6.0 Annex 6	77

ANNEX 1

Milestones

ID	Task Mode	Task Name	Duration	Start	Finish	Predecessors	Resource Names	2nd Quarter		
								Apr	May	Jun
1		5 Problem Proposals	0 days	Wed 9/18/19	Wed 9/18/19					
2		2 Problem Proposals	0 days	Wed 10/02/19	Wed 10/02/19					
3		Problem Definition	0 days	Wed 10/09/19	Wed 10/09/19					
4		User Trip Summary	0 days	Wed 10/16/19	Wed 10/16/19					
5		Merging and Reflection Report	0 days	Wed 10/16/19	Wed 10/16/19					
6		HDP 5 Directions	0 days	Wed 10/23/19	Wed 10/23/19					
7		Research Poster Review	0 days	Wed 11/20/19	Wed 11/20/19					
8		Research Poster	0 days	Wed 11/27/19	Wed 11/27/19					
9		HDP Concept Criteria	0 days	Thu 1/09/20	Thu 1/09/20					
10		HDP Concepts	0 days	Wed 1/22/20	Wed 1/22/20					
11		HDP Proof of Concept	0 days	Wed 3/04/20	Wed 3/04/20					
12		Final Submission	0 days	Wed 5/06/20	Wed 5/06/20					
13		Student Defense	0 days	Thu 5/07/20	Thu 5/07/20					
14		External Assessment	0 days	Wed 5/13/20	Wed 5/13/20					
15		Open Exhibiton	0 days	Fri 5/22/20	Fri 5/22/20					

Project: Milestones
Date: 7/7/2020 5:01 AM

Task		Project Summary		Inactive Milestone		Summary Rollup		Progress	
Split		External Tasks		Inactive Summary		Manual Summary		Deadline	
Milestone		External Milestone		Manual Task		Start-only			
Summary		Inactive Task		Duration-only		Finish-only			

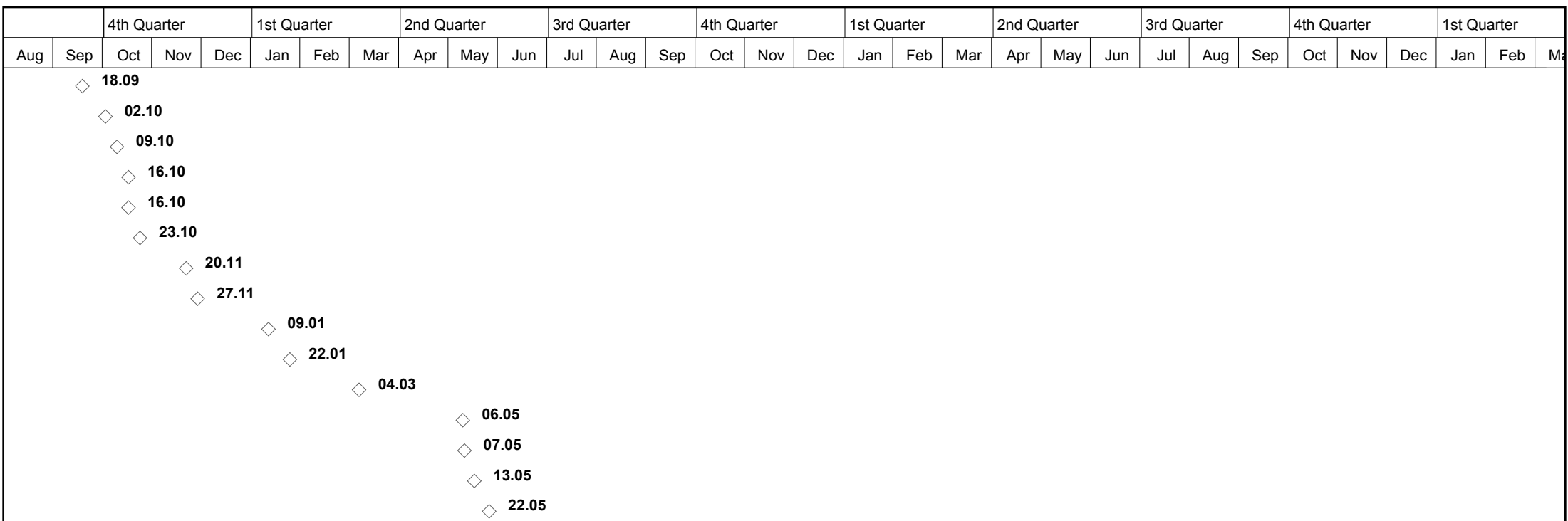





























Project: Milestones
Date: 7/7/2020 5:01 AM

Task		Project Summary		Inactive Milestone		Summary Rollup		Progress	
Split		External Tasks		Inactive Summary		Manual Summary		Deadline	
Milestone		External Milestone		Manual Task		Start-only			
Summary		Inactive Task		Duration-only		Finish-only			



























ANNEX 2

Project Planning

ID		Task Mode	Task Name	Duration	Start	Finish	Predecessors
1			Phase 1 Problem Definition	21 days	Wed 9/11/19	Wed 10/09/19	
2			5 problem proposals	6 days	Wed 9/11/19	Wed 9/18/19	
3			Identify Problem Areas	4 days	Wed 9/11/19	Mon 9/16/19	
4			Research and Discard Problem Areas	3 days	Thu 9/12/19	Mon 9/16/19	
5			Selection of Problem Proposals	2 days	Sat 9/14/19	Mon 9/16/19	
6			Problem Proposals Delivery Preparation	2 days	Tue 9/17/19	Wed 9/18/19	
7			2 problem proposals	11 days	Wed 9/18/19	Wed 10/02/19	
8			Background Research	8 days	Wed 9/18/19	Fri 9/27/19	
9			Situation Research	6 days	Fri 9/20/19	Fri 9/27/19	
10			User Research	6 days	Sun 9/22/19	Fri 9/27/19	
11			Analysis of Results	2 days	Fri 9/27/19	Sun 9/29/19	
12			2 Problem Selection	4 days	Wed 9/18/19	Sat 9/21/19	
13			Presentation	3 days	Mon 9/30/19	Wed 10/02/19	
14			Problem Definition	6 days	Wed 10/02/19	Wed 10/09/19	
15			Final Problem Selection	2 days	Wed 10/02/19	Thu 10/03/19	
16			Problem Definition Research	3 days	Thu 10/03/19	Sun 10/06/19	
17			Scope Research	2 days	Fri 10/04/19	Mon 10/07/19	
18			Research Plan	3 days	Sun 10/06/19	Tue 10/08/19	
19			Presentation	3 days	Mon 10/07/19	Wed 10/09/19	
20			Phase 2 Project Direction	36 days	Wed 10/09/19	Wed 11/27/19	
21			Research	11 days	Wed 10/09/19	Wed 10/23/19	
22			User Trips	9 days	Wed 10/09/19	Sun 10/20/19	
23			User Trip Summary	2 days	Tue 10/15/19	Wed 10/16/19	
24			Extrapolation and Understanding of Findings	4 days	Wed 10/16/19	Sun 10/20/19	
25			5 Problem Directions	4 days	Sun 10/20/19	Wed 10/23/19	
26			Research Poster	25 days	Thu 10/24/19	Wed 11/27/19	

Project: Project Planning Gantt Chart
Date: 7/7/2020 5:01 AM

Task		Project Summary		Inactive Milestone		Summary Rollup		Progress	
Split		External Tasks		Inactive Summary		Manual Summary		Deadline	
Milestone		External Milestone		Manual Task		Start-only			
Summary		Inactive Task		Duration-only		Finish-only			

ID		Task Mode	Task Name	Duration	Start	Finish	Predecessors
27			5 Problem Directions Focused Research	6 days	Thu 10/24/19	Thu 10/31/19	
28			Analysis of Results	3 days	Thu 10/31/19	Sat 11/02/19	
29			Desk Research	19 days	Thu 10/24/19	Tue 11/19/19	
30			Field Research	23 days	Thu 10/24/19	Mon 11/25/19	
31			Research Poster Elaboration	14 days	Sun 11/03/19	Wed 11/20/19	
32			Research Poster Refining	5 days	Thu 11/21/19	Wed 11/27/19	
33			Project Research Gap Findings	3 days	Wed 11/13/19	Fri 11/15/19	
34			Crazy Wall	9 days	Sun 11/10/19	Wed 11/20/19	
35			Project Key Findings Identification	4 days	Sat 11/16/19	Wed 11/20/19	
36			Phase 3 Conceptualization	71 days	Wed 11/27/19	Wed 3/04/20	
37			Concept Generation	41 days	Wed 11/27/19	Wed 1/22/20	
38			Task Analysis/Will's and Wont's	6 days	Mon 12/02/19	Mon 12/09/19	
39			Human Centred Design Categorisation Chart	10 days	Tue 1/07/20	Mon 1/20/20	
40			User Journey/Touchpoints Map	22 days	Mon 12/09/19	Tue 1/07/20	
41			Concept Generation/Sketching	41 days	Wed 11/27/19	Wed 1/22/20	
42			Proof of Concept	28 days	Mon 1/27/20	Wed 3/04/20	
43			Proof of Concept	28 days	Mon 1/27/20	Wed 3/04/20	
44			Phase 4 Materialisation	57 days	Mon 1/27/20	Tue 4/14/20	
45			Workshop	57 days	Mon 1/27/20	Tue 4/14/20	
46			Worshop Working	57 days	Mon 1/27/20	Tue 4/14/20	
47			Phase 5 Presentation	17 days	Wed 4/15/20	Thu 5/07/20	
48			Final Submission	16 days	Wed 4/15/20	Wed 5/06/20	
49			Preparing Final Submission	16 days	Wed 4/15/20	Wed 5/06/20	
50			Student Defense	17 days	Wed 4/15/20	Thu 5/07/20	
51			Preparing Defense	17 days	Wed 4/15/20	Thu 5/07/20	

Project: Project Planning Gantt Chart
Date: 7/7/2020 5:01 AM

Task		Project Summary		Inactive Milestone		Summary Rollup		Progress	
Split		External Tasks		Inactive Summary		Manual Summary		Deadline	
Milestone		External Milestone		Manual Task		Start-only			
Summary		Inactive Task		Duration-only		Finish-only			

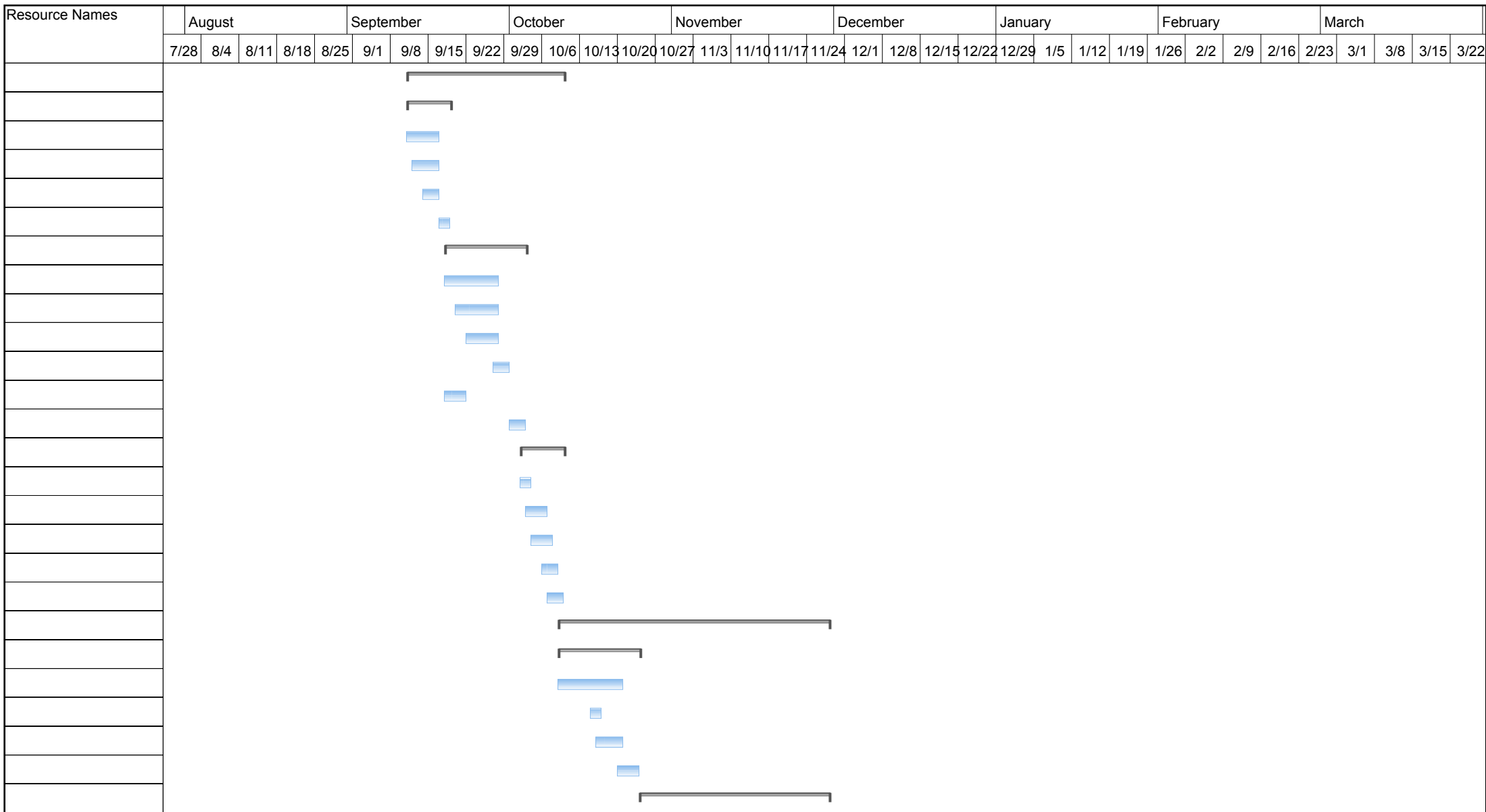

Project: Project Planning Gantt Chart
Date: 7/7/2020 5:01 AM

Task		Project Summary		Inactive Milestone		Summary Rollup		Progress	
Split		External Tasks		Inactive Summary		Manual Summary		Deadline	
Milestone		External Milestone		Manual Task		Start-only			
Summary		Inactive Task		Duration-only		Finish-only			

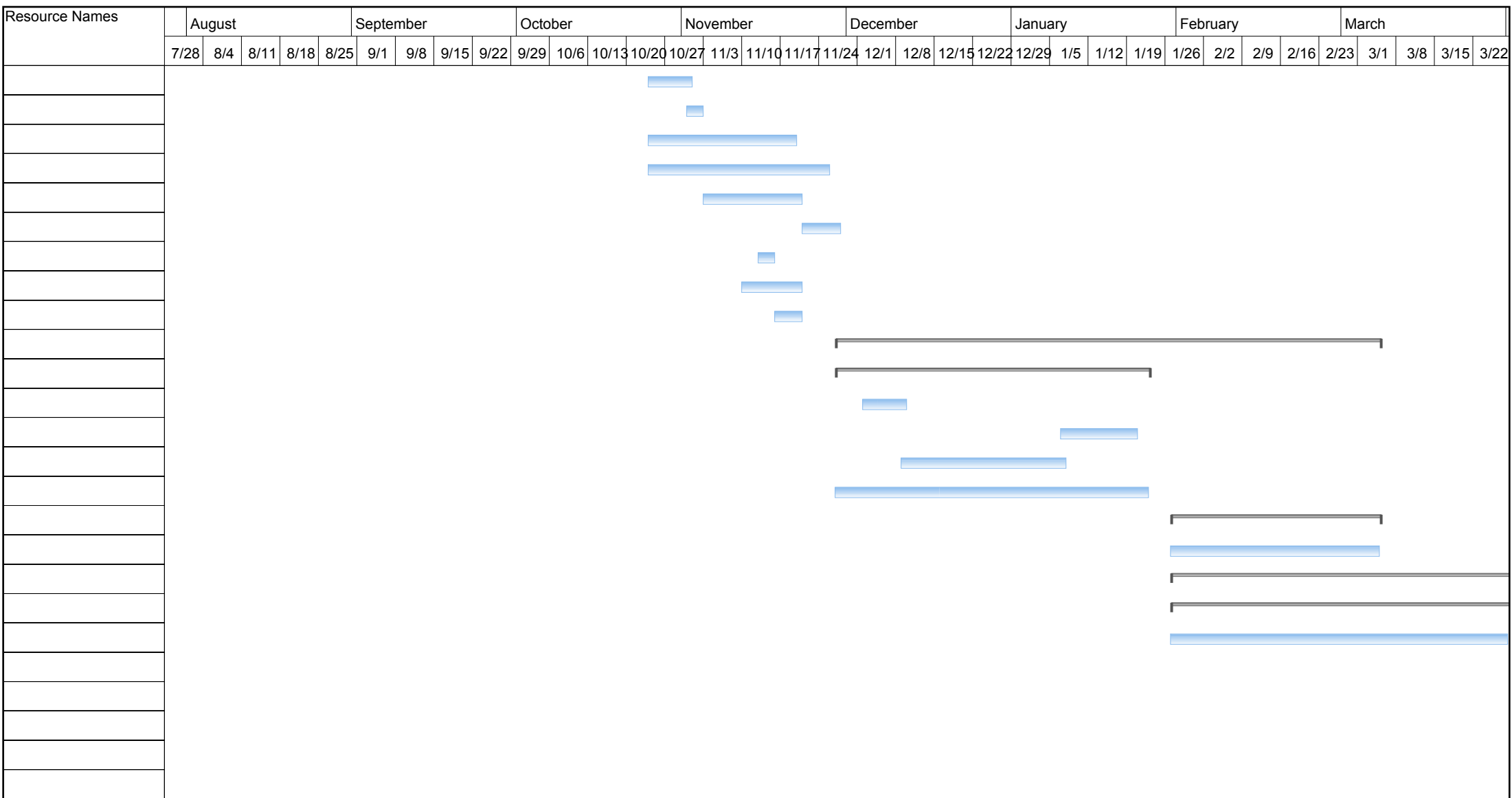

Project: Project Planning Gantt Chart
Date: 7/7/2020 5:01 AM

Task	Project Summary	Inactive Milestone	Summary Rollup	Progress
Split	External Tasks	Inactive Summary	Manual Summary	Deadline
Milestone	External Milestone	Manual Task	Start-only	
Summary	Inactive Task	Duration-only	Finish-only	

ANNEX 3

Proof of Concept

TRAUMATIC EXPERIENCES DURING VACCINATION

How can they be prevented?

- Education
- Parent behaviour
- Perspective
- Exposure to the process
- State of mind

When can this be addressed?

BEFORE THE VACCINE

FOCUS ON THE CHILD MENTALITY IN ALL THE STEPS OF THE PROCESS

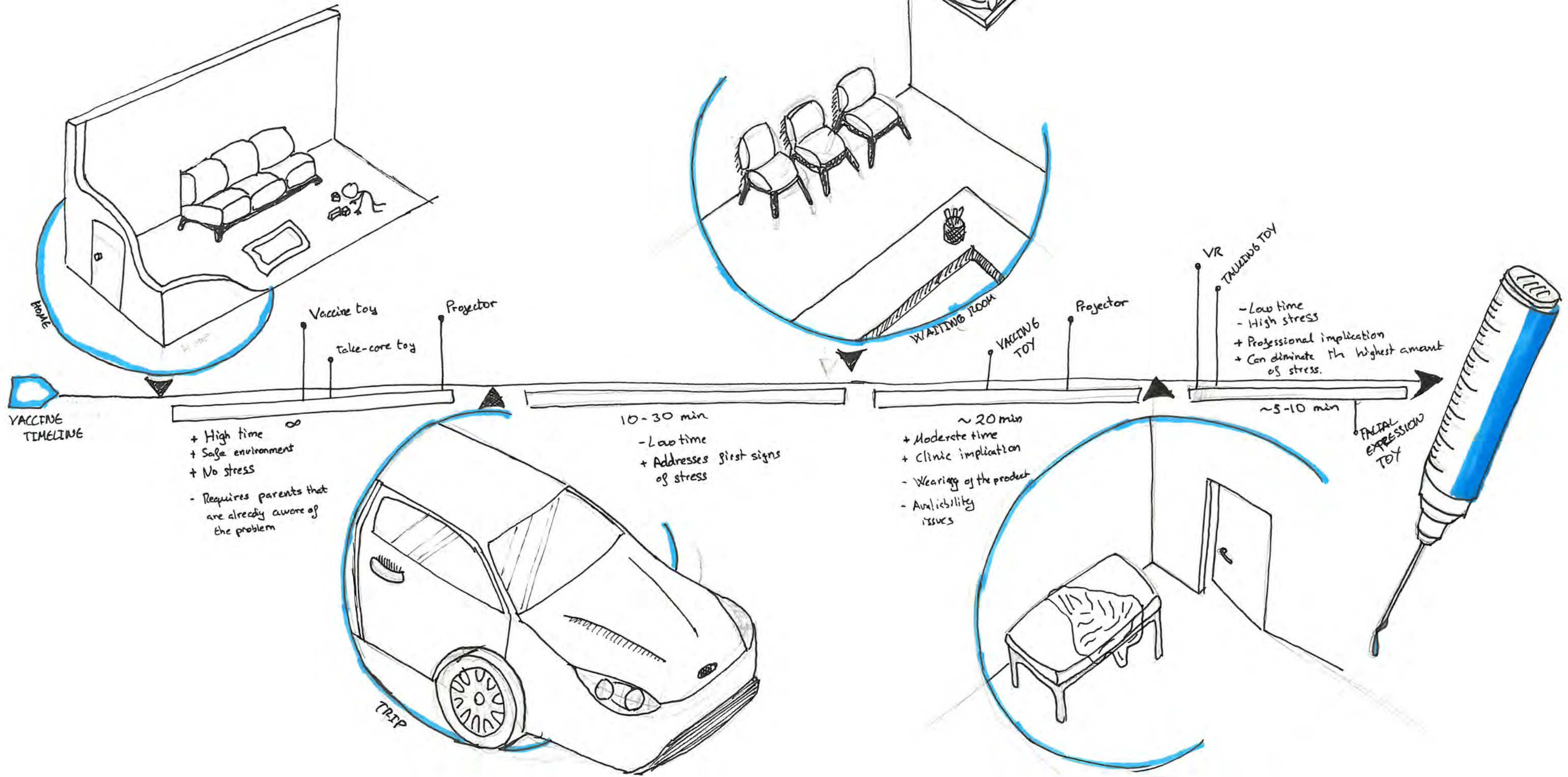

Needle stamp toy

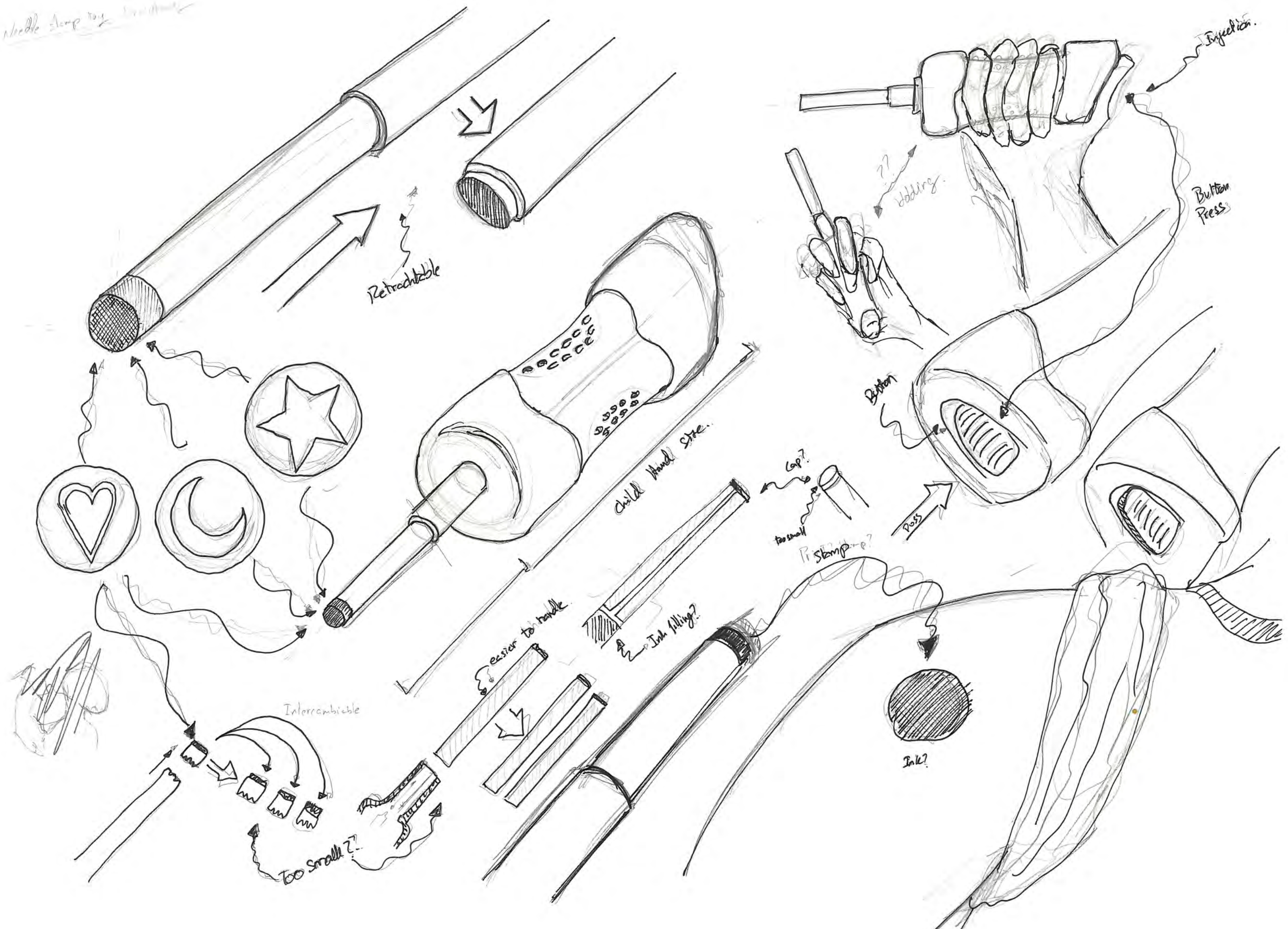

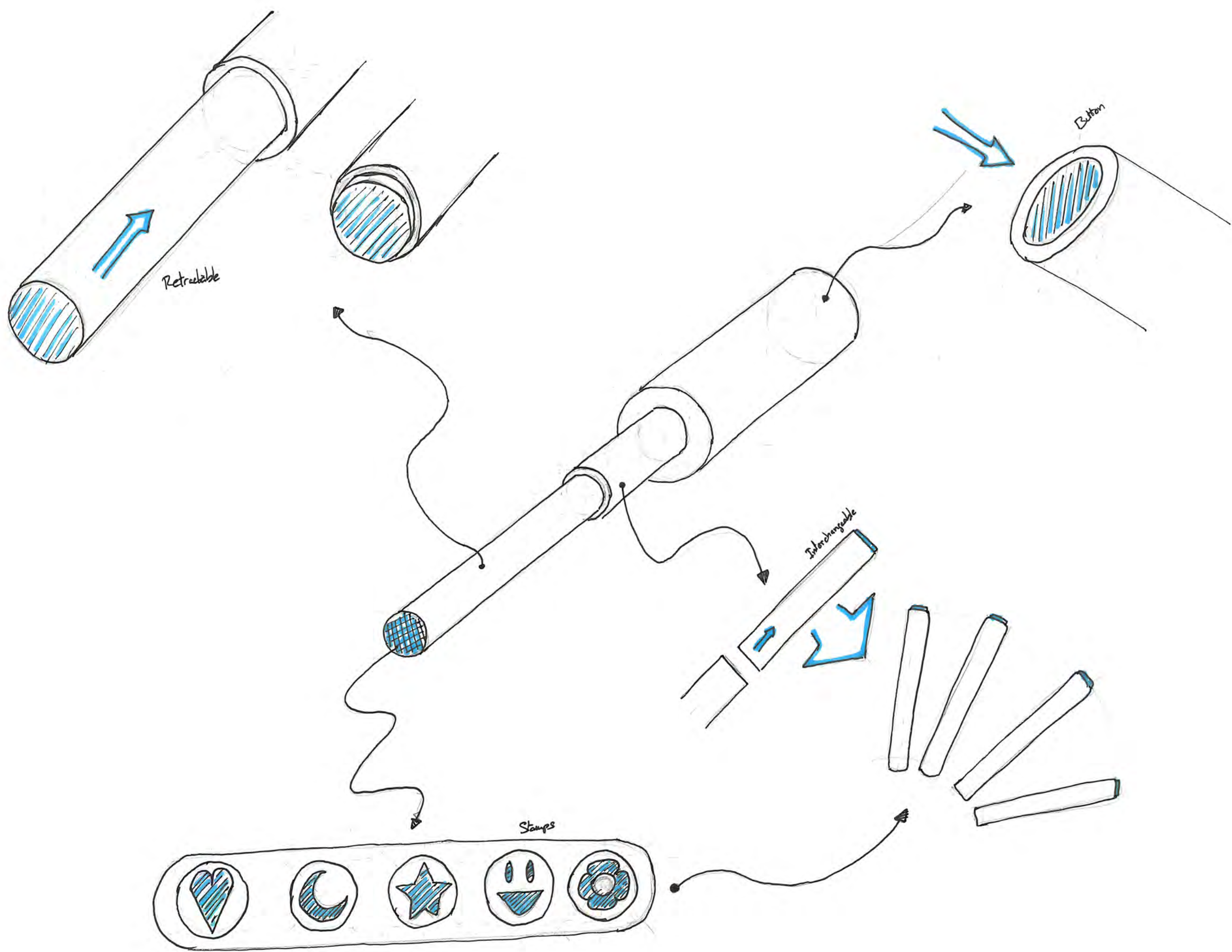

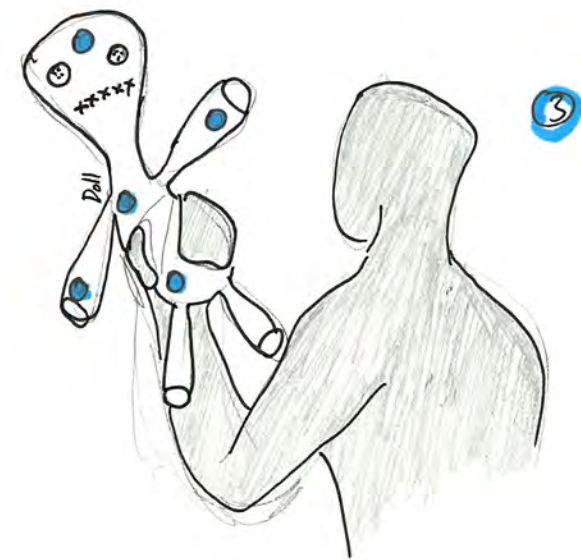
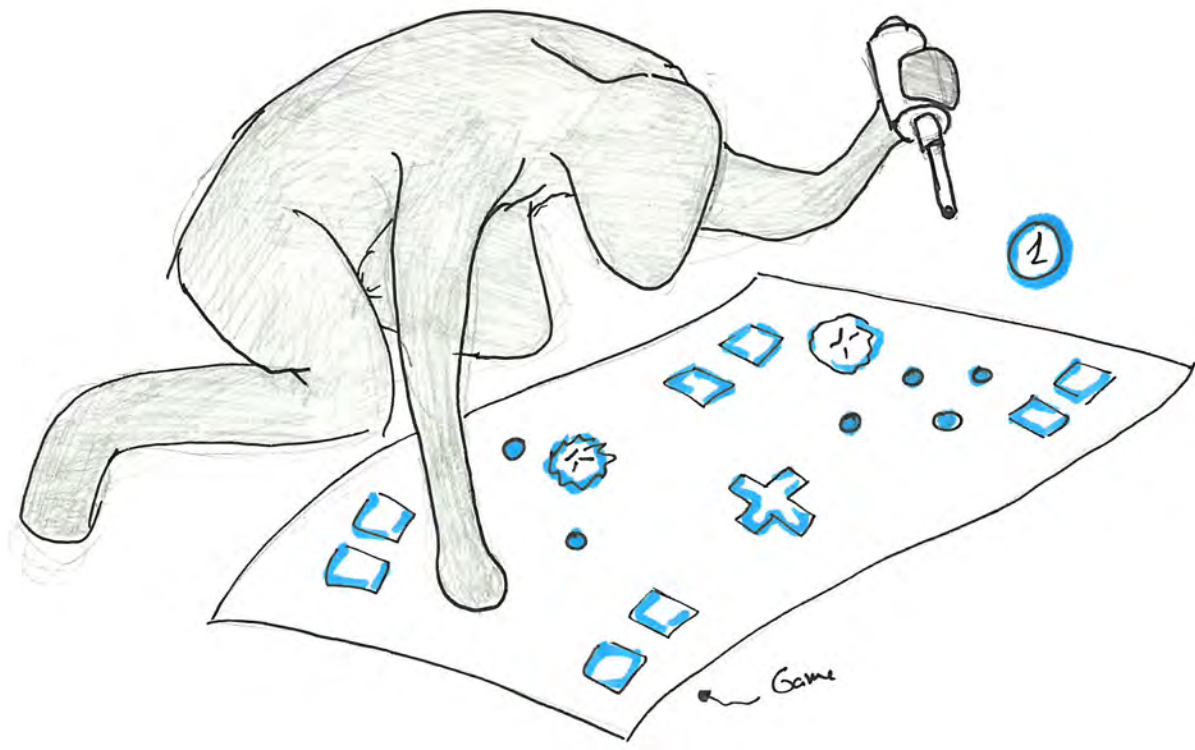
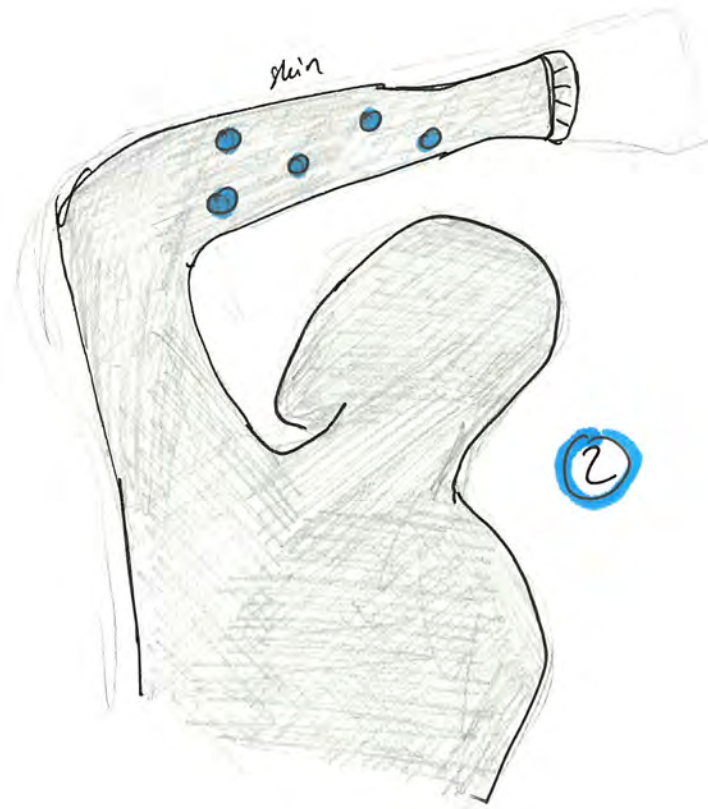
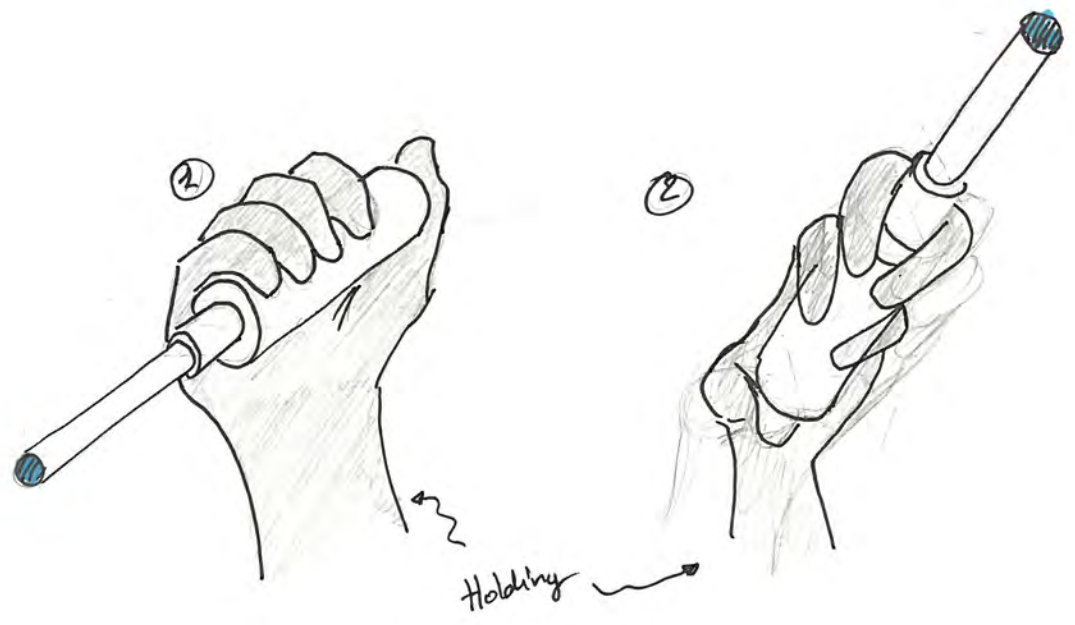

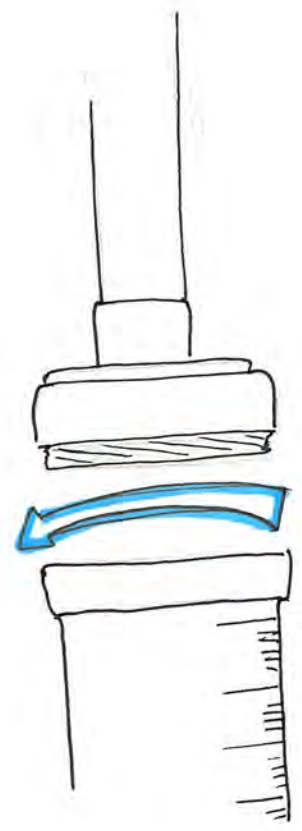

Refillable

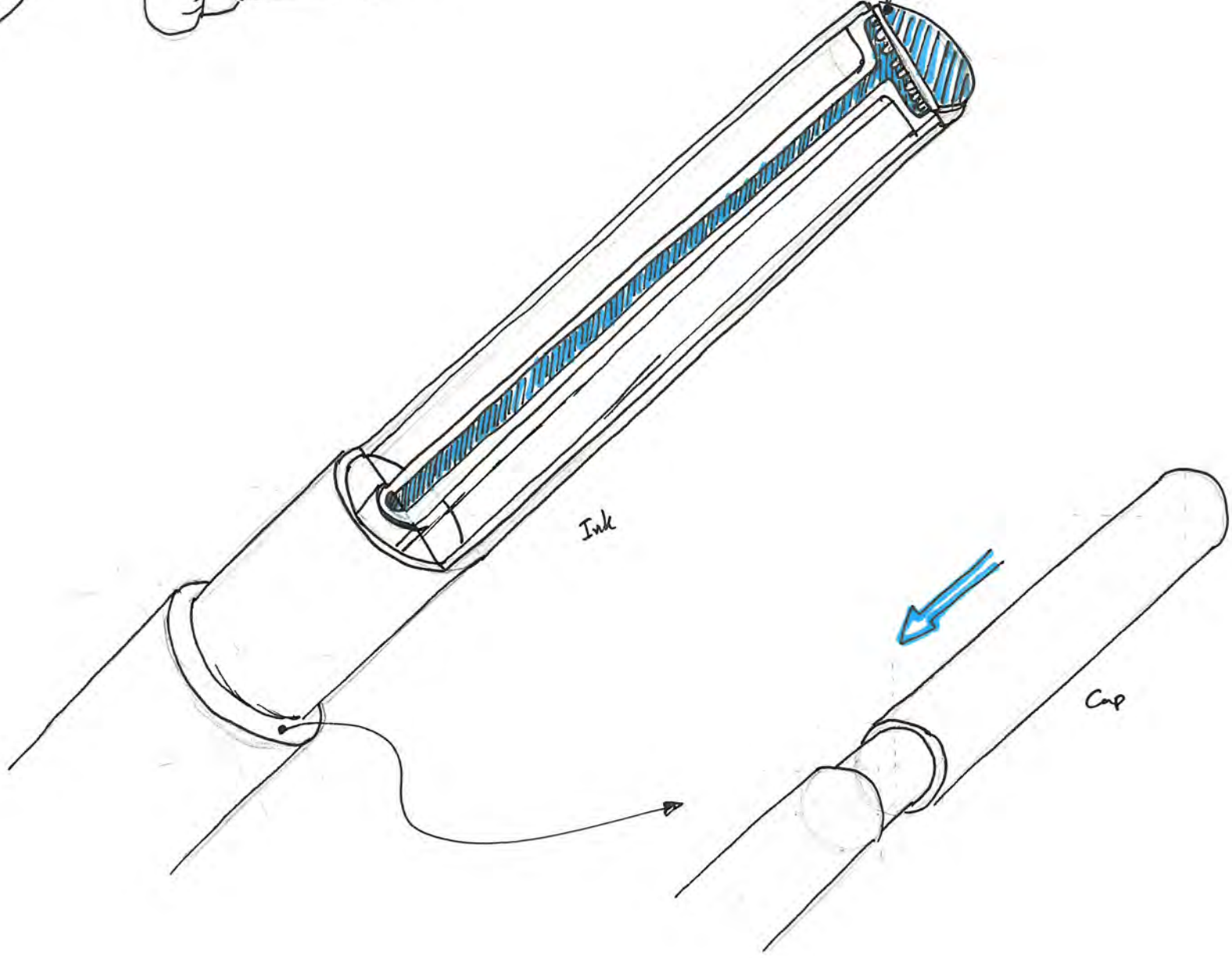
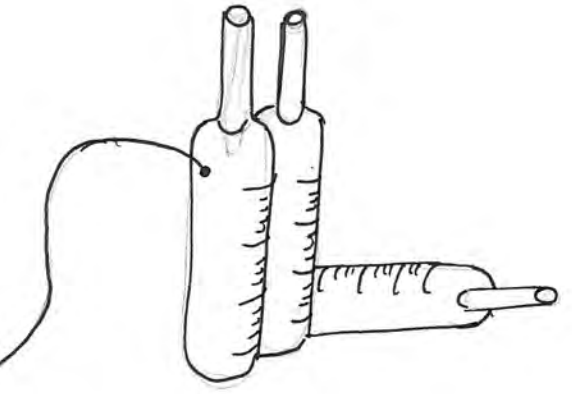

Ink

Cap

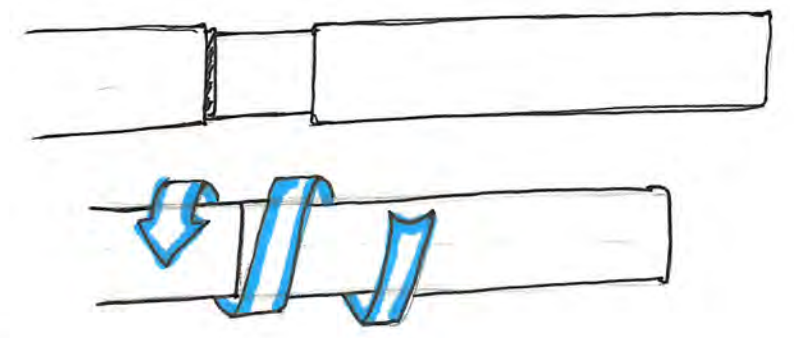
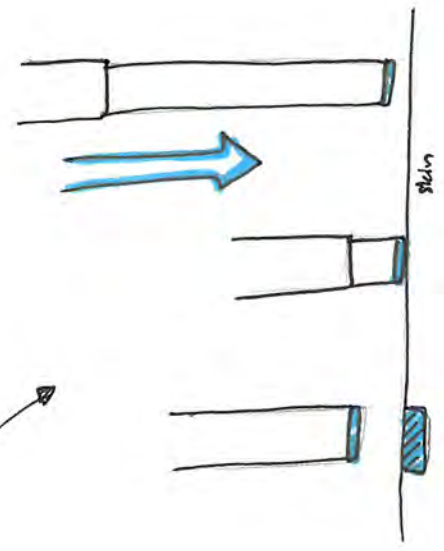

PLAY
AREA

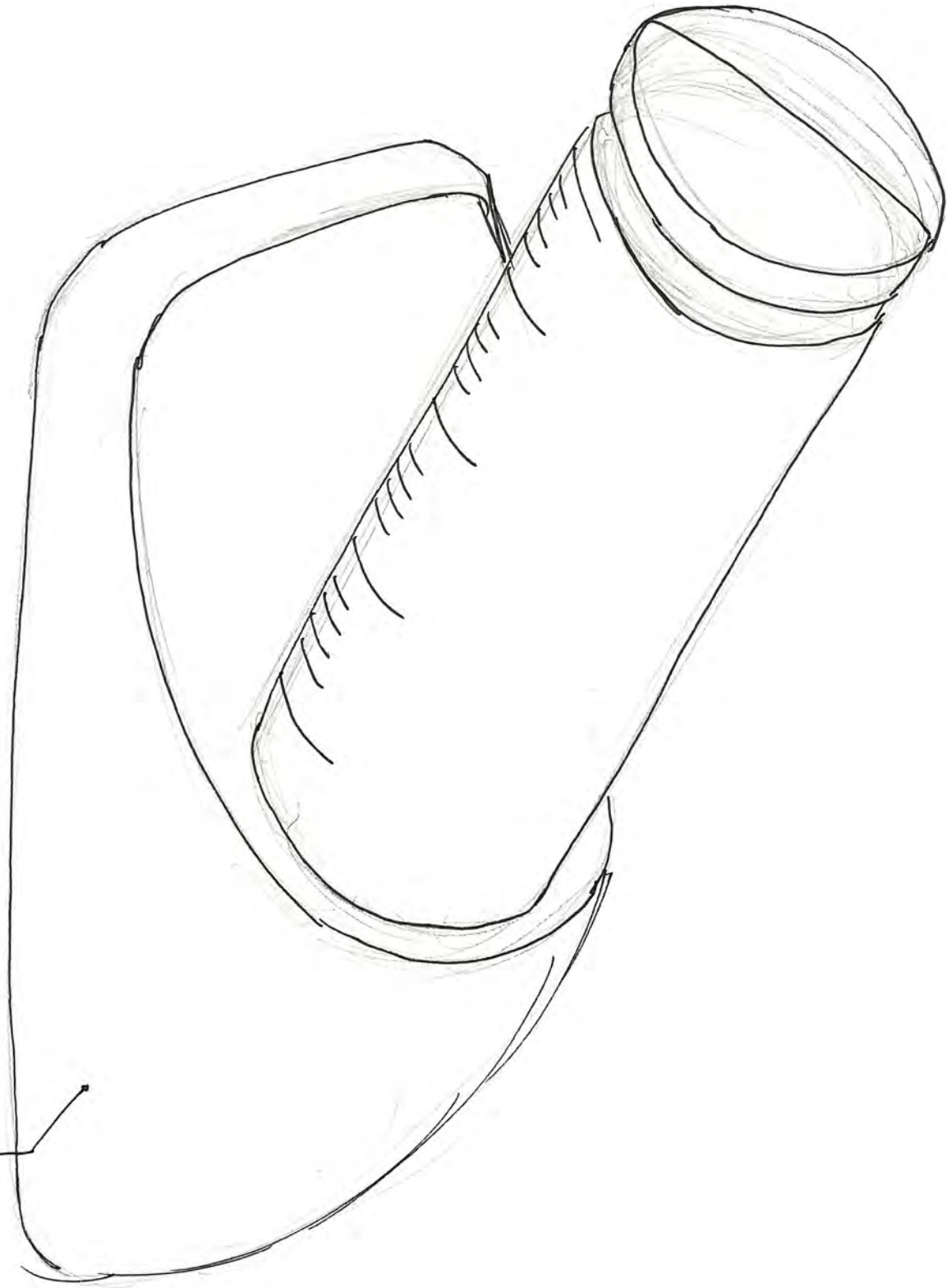
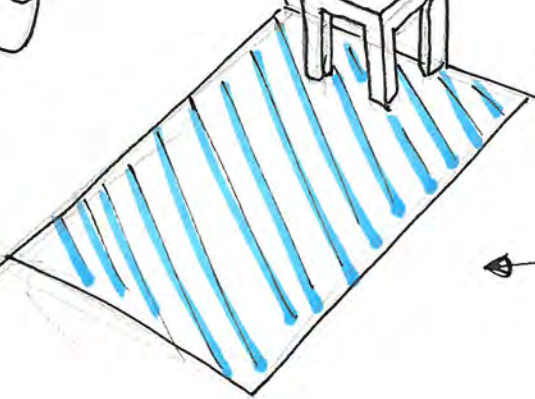



LIGHT



ALIEN DOCTOR



PROVIDES INFORMATION



PUSH

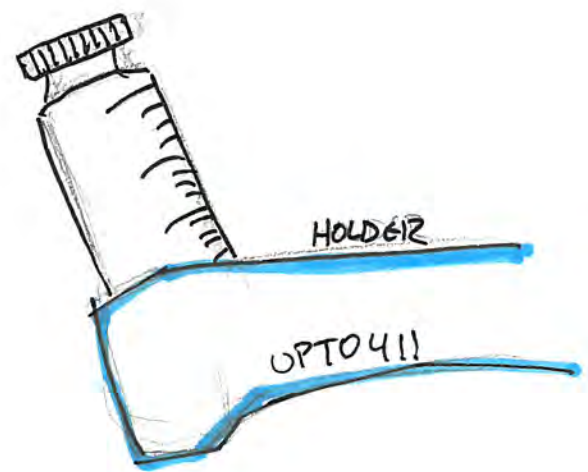
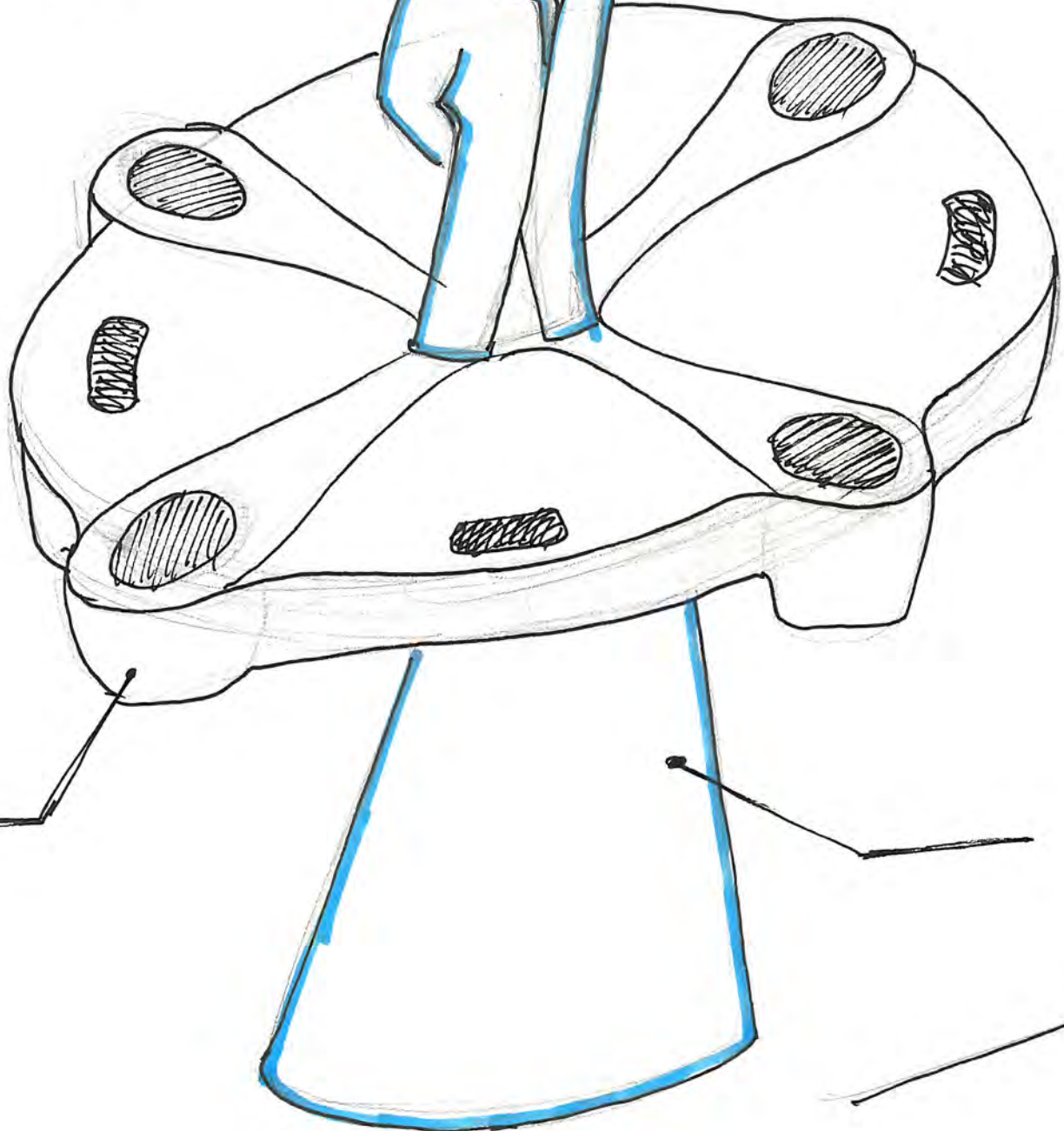

HOLDER

OPTO411



WAITING ROOM

Vaccination toy
3m information
functions

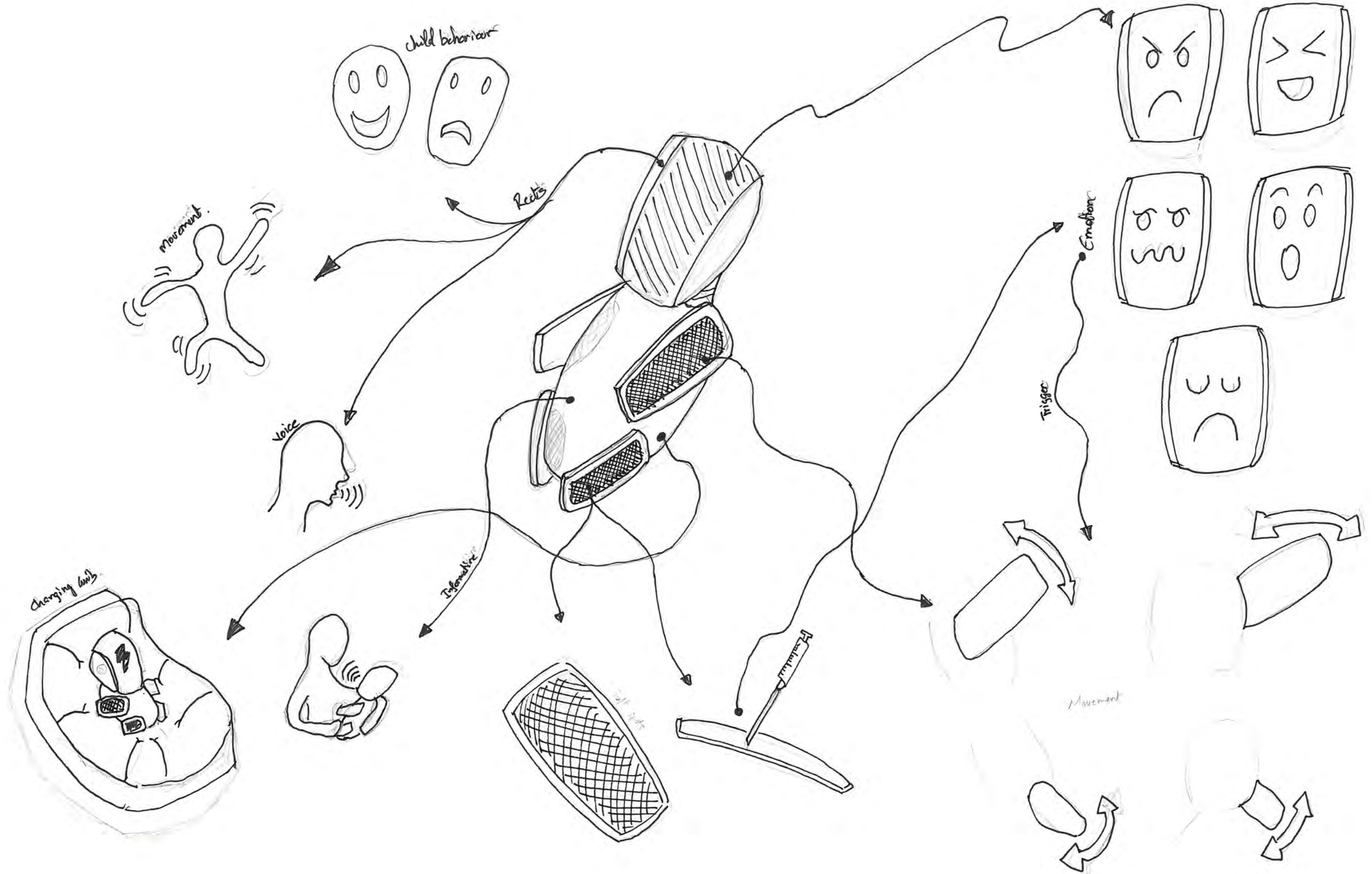

HOM6
TIMELINE

SIZE & NERVOUS



2

STEAK



SMILE



PARENTS
WATCH &
LEARN

6

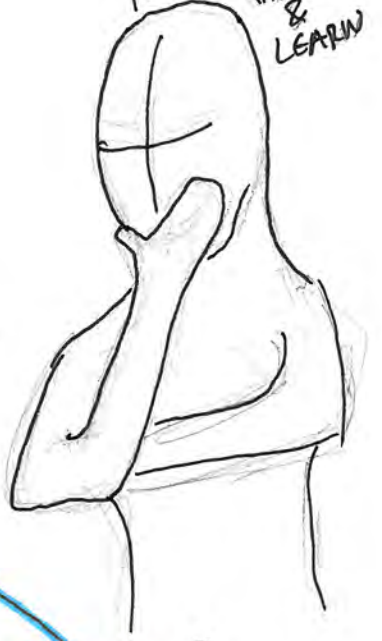

MOVE



HAPPY

5

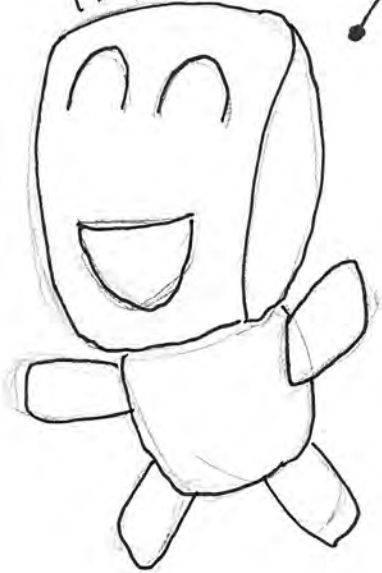

IMPROVED MOOD

3

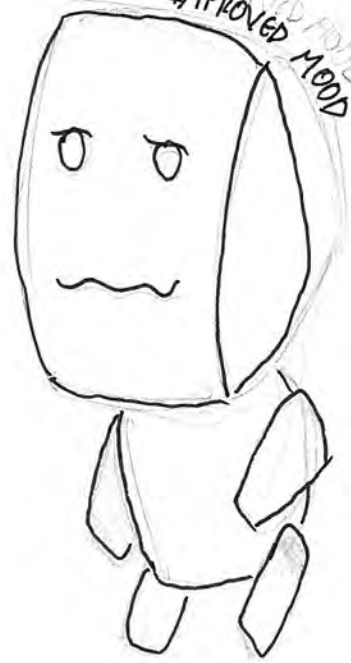

VACCINATION
TIME

4

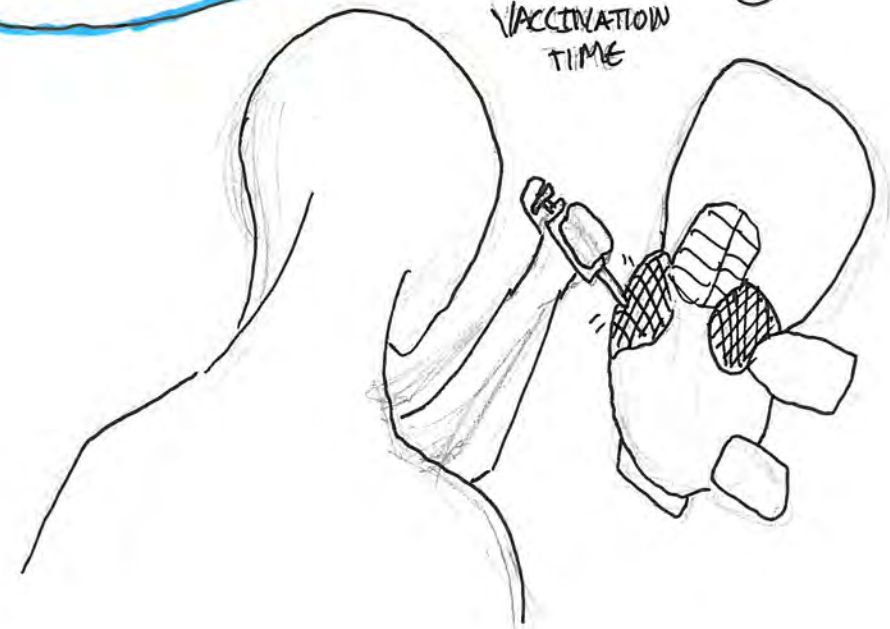

TO THE
CONSULT



OUT OF HOME
TIMELINE

TRIP ①

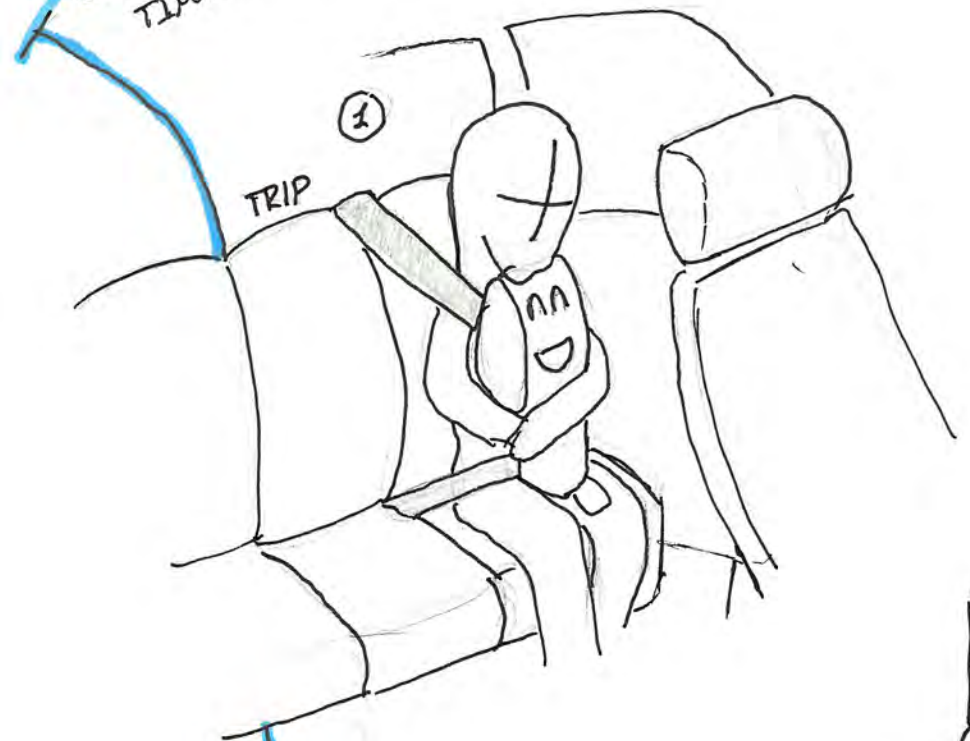

② WAITING ROOM

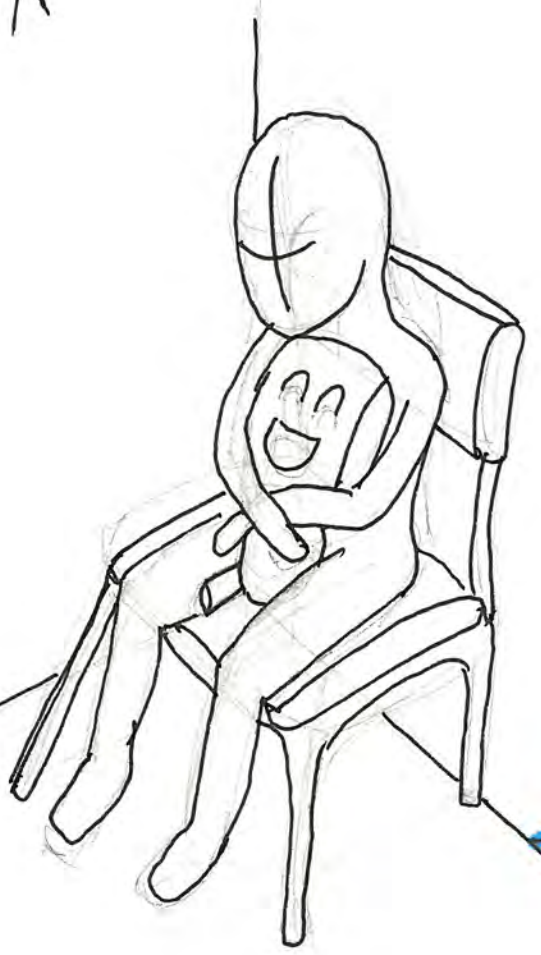

CONSULT

③

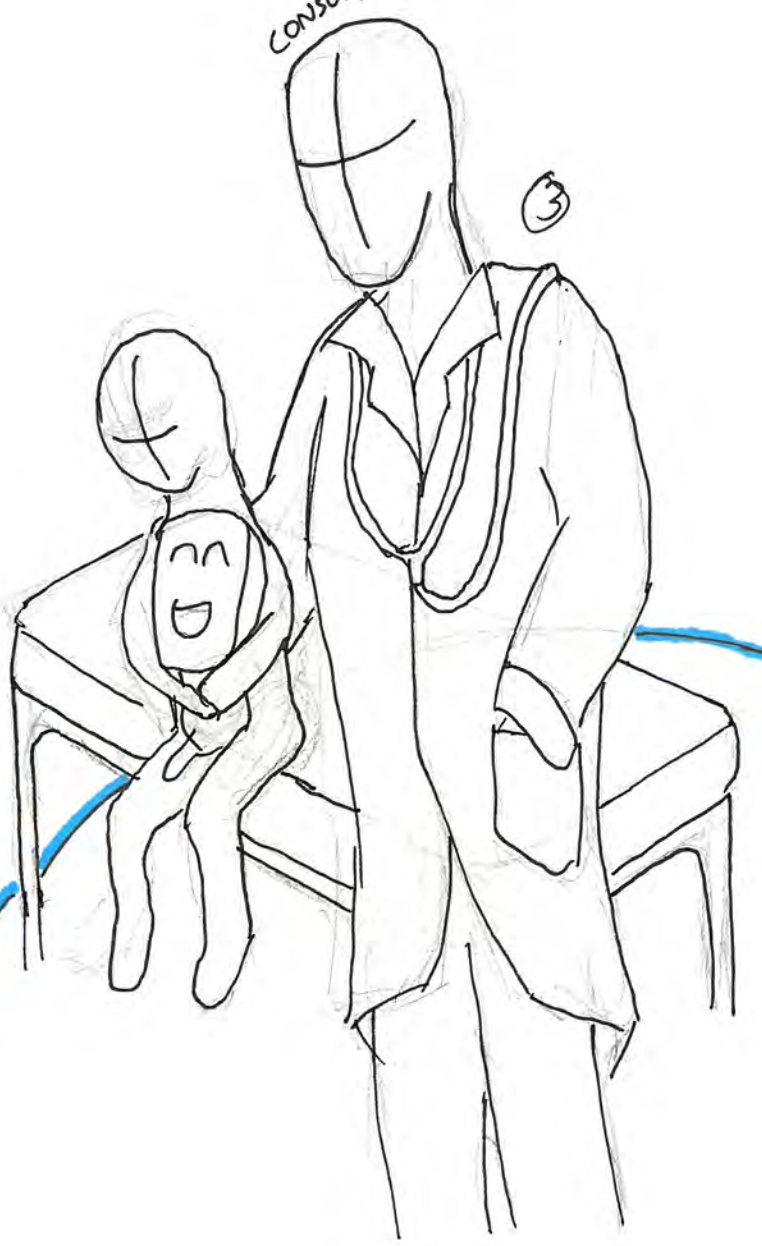

PUNCTURE





Handwritten text in blue ink, possibly a signature or initials, located in the upper right corner of the page.

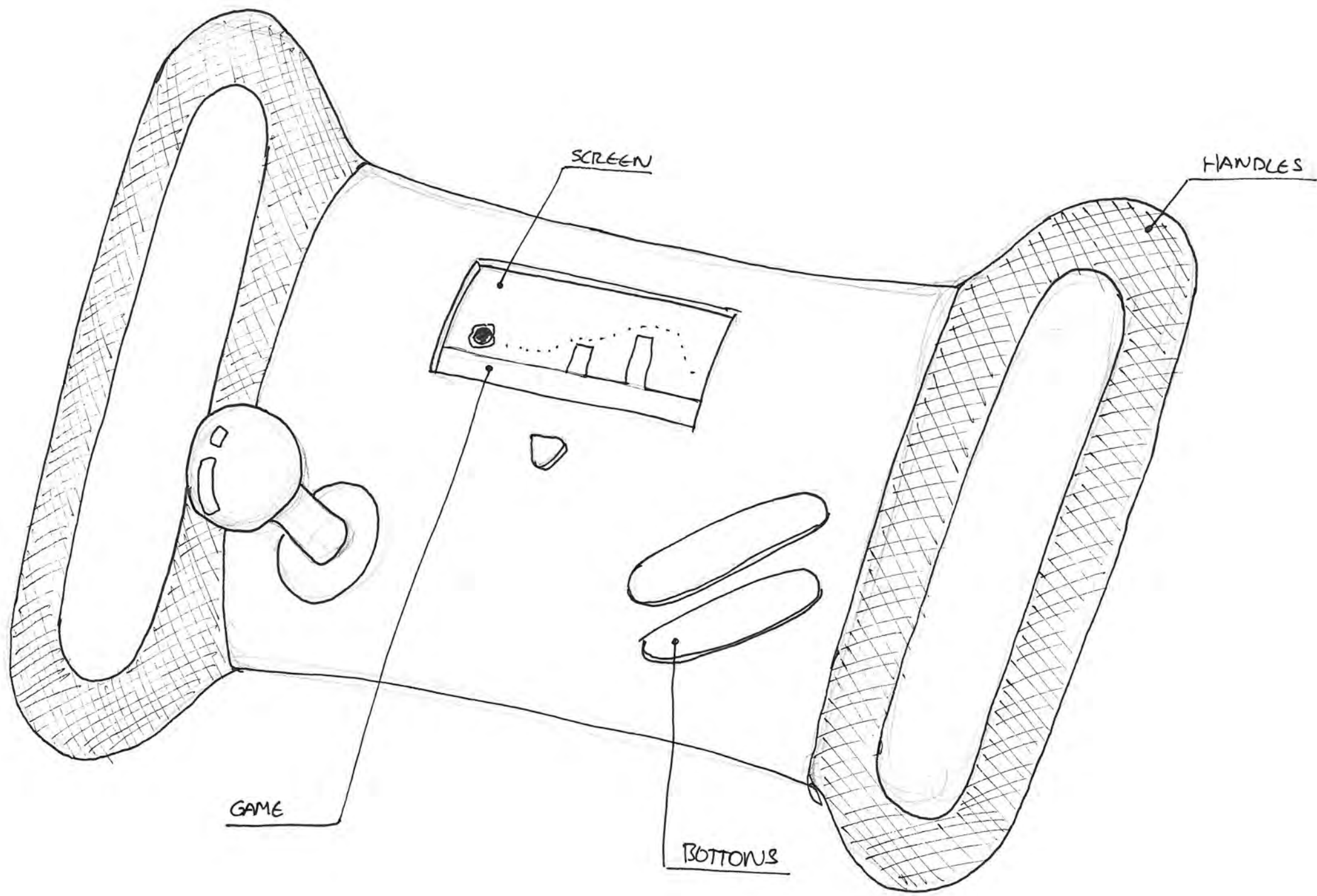

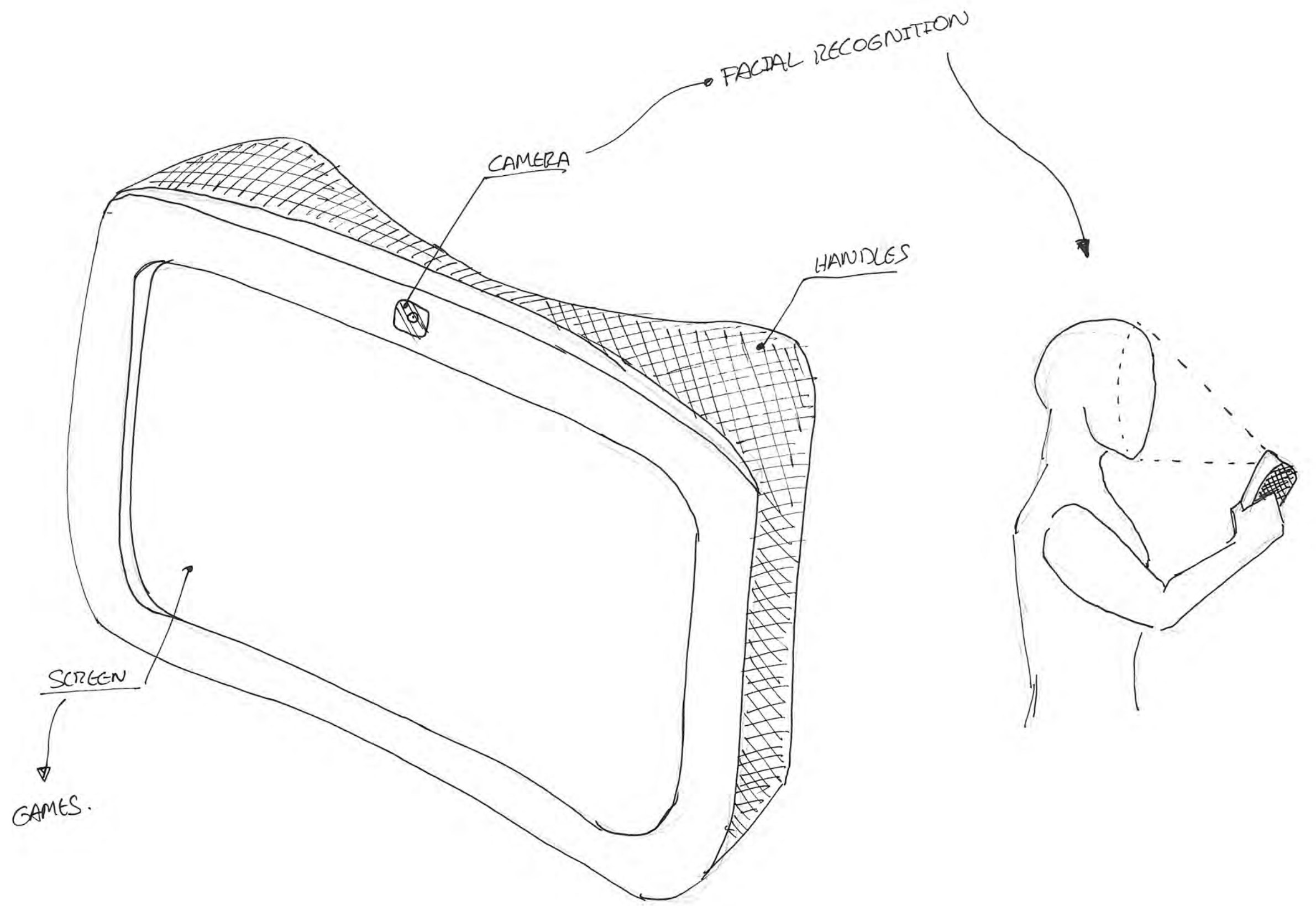

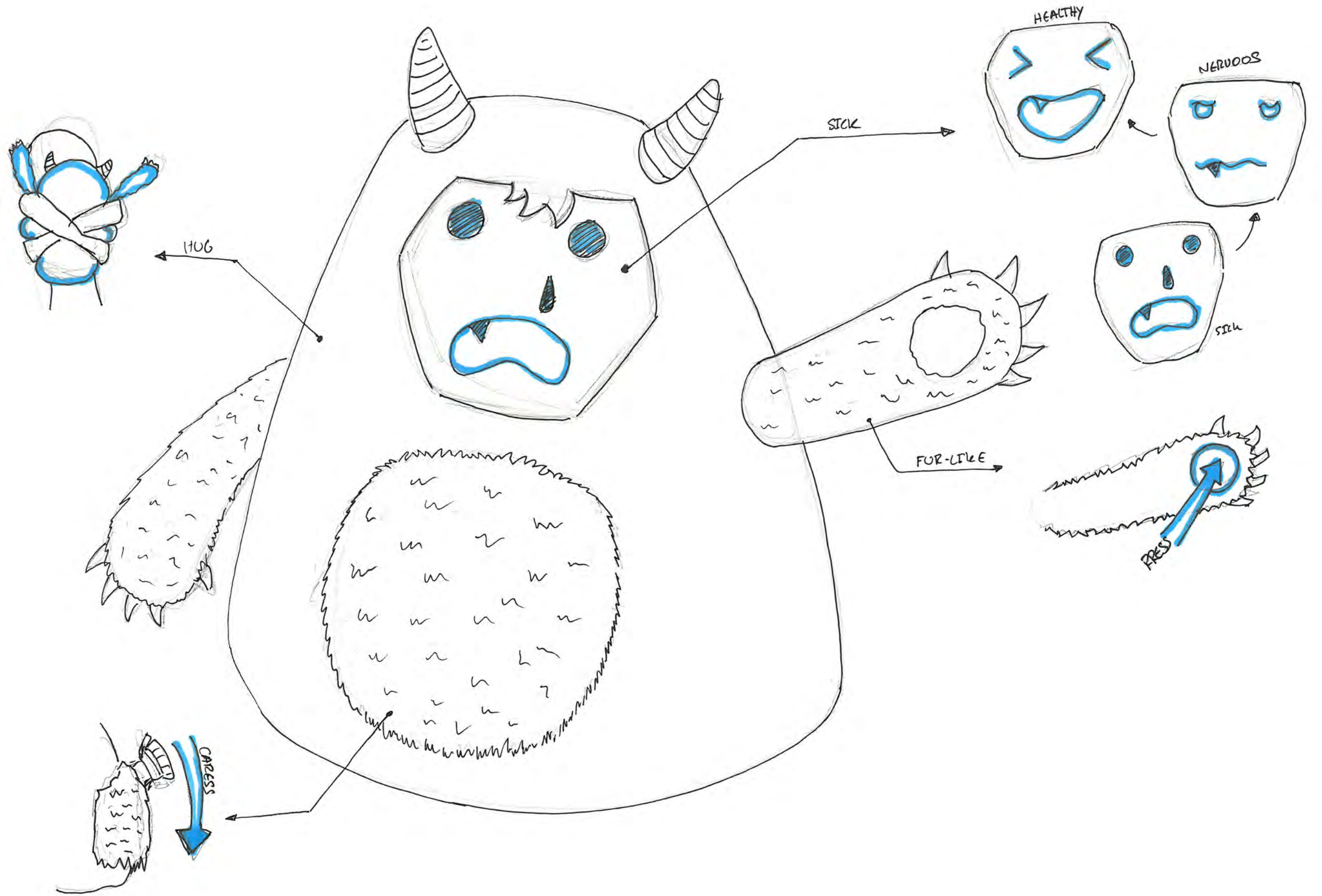

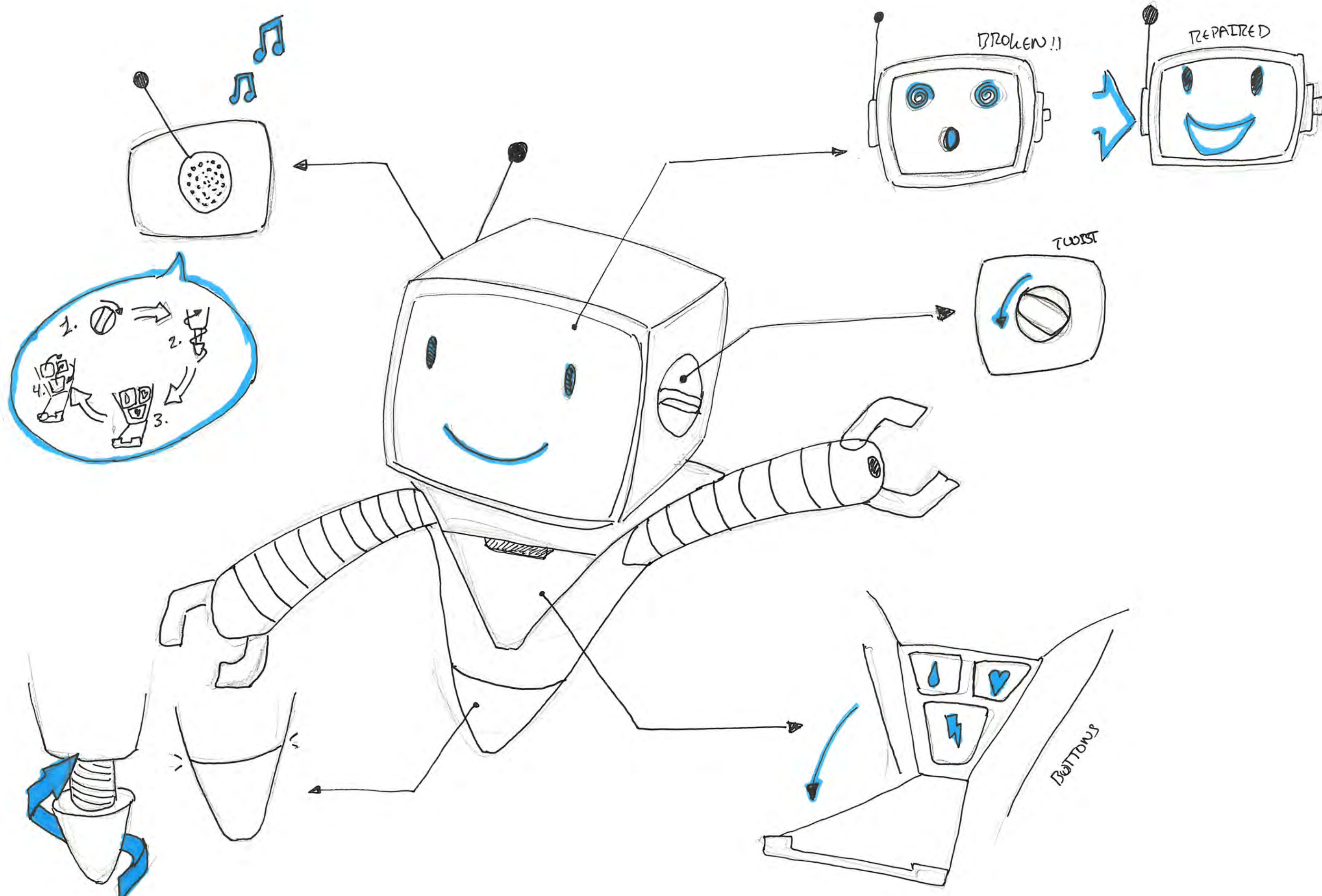

ENTER THE CONSULT

1

2

3

4

5

6

7

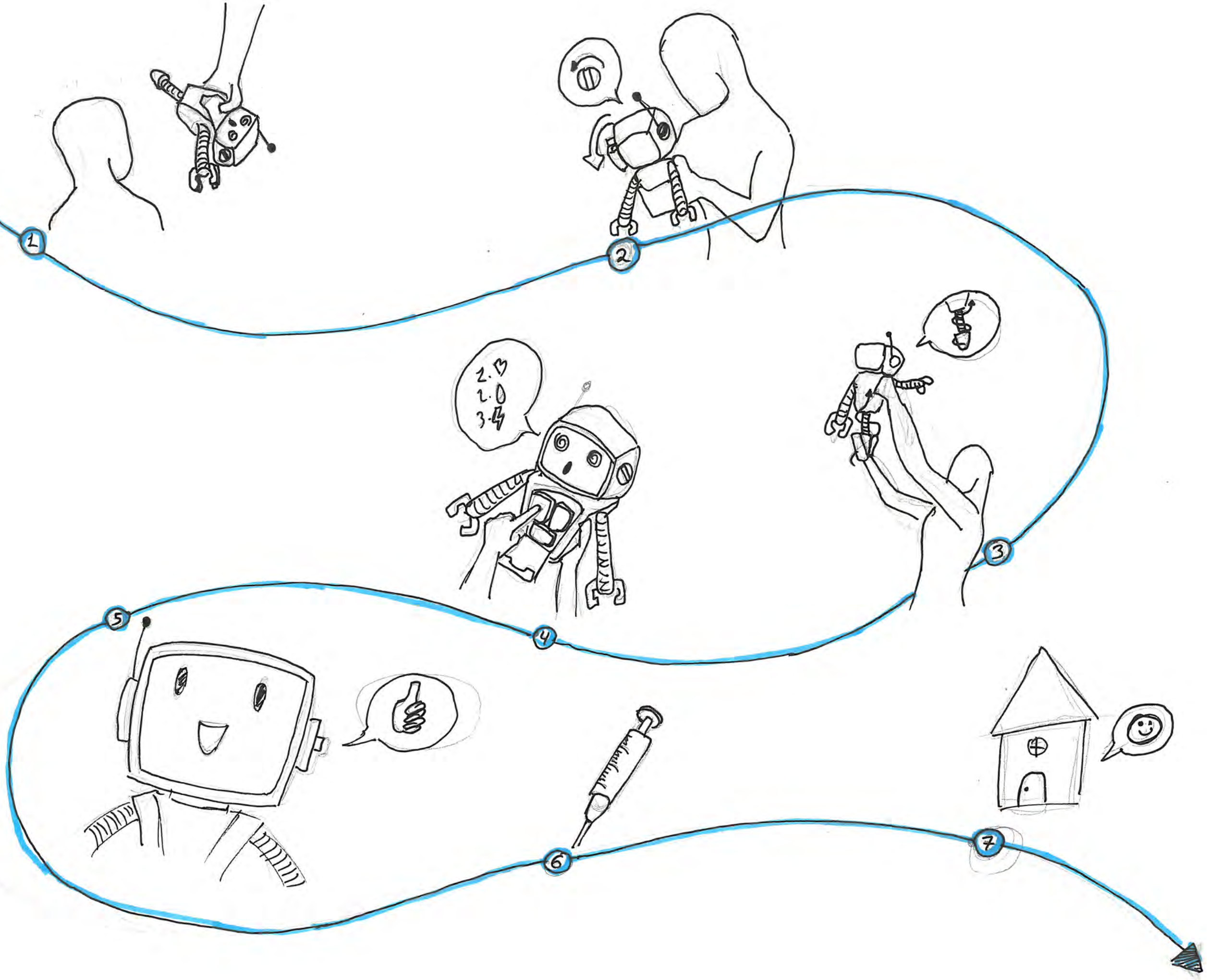

Projective
display

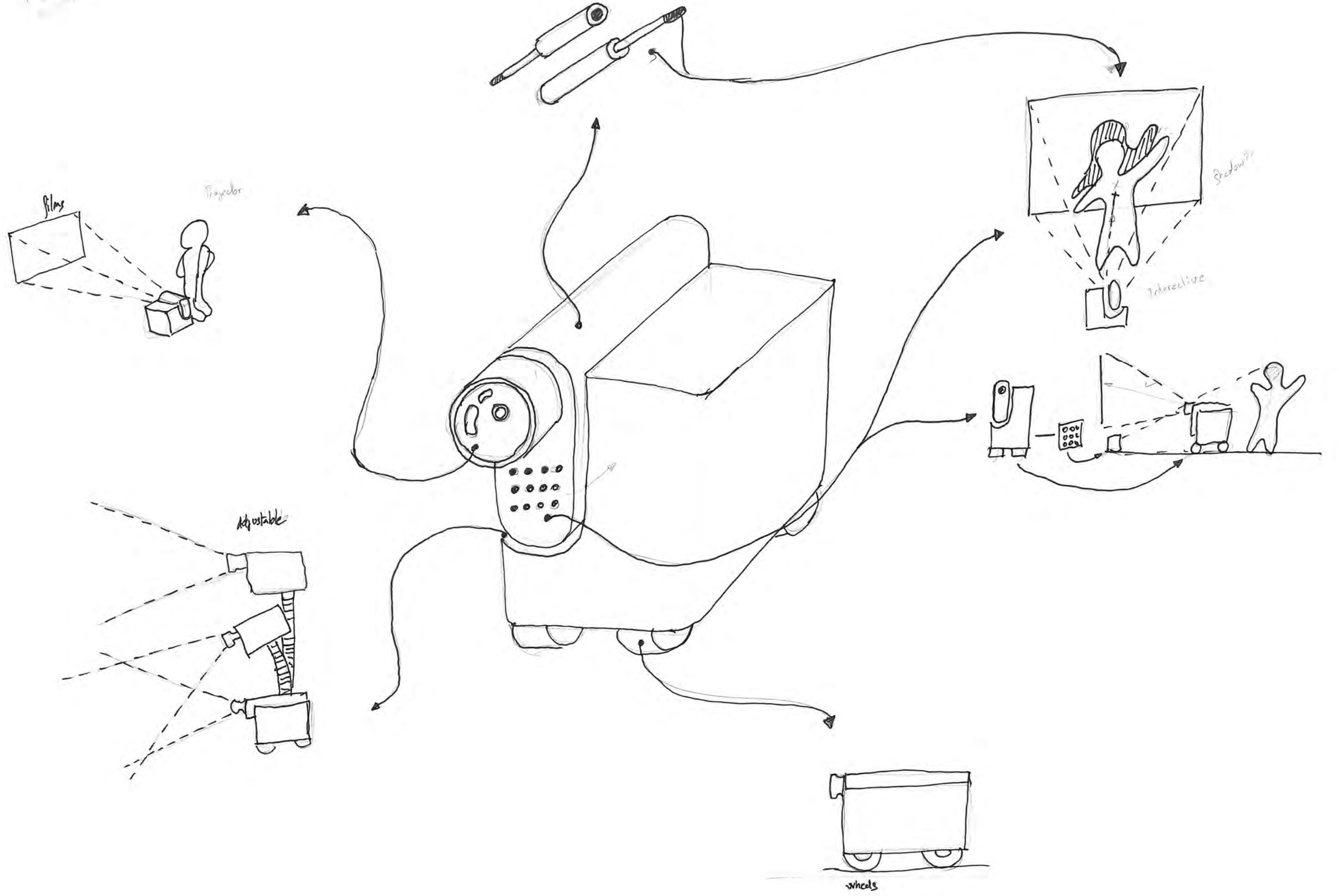

Virtual Reality

3-4 years old

- Easy to use
- Intuitive

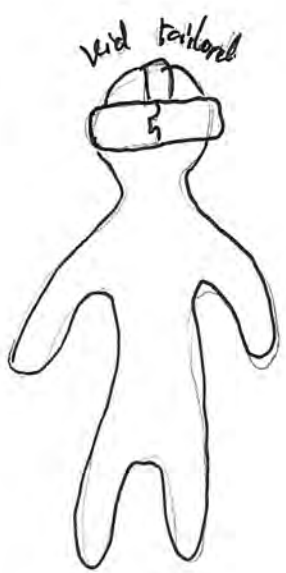
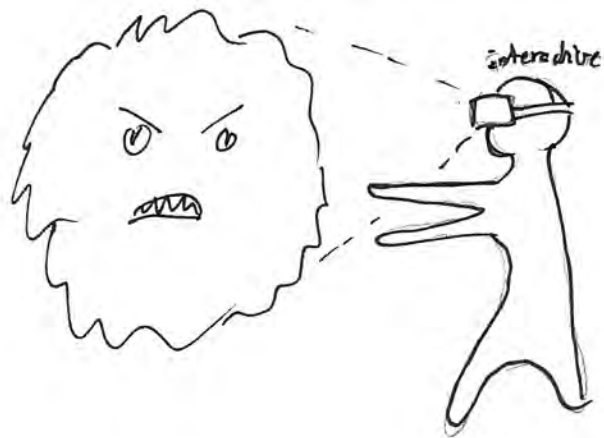
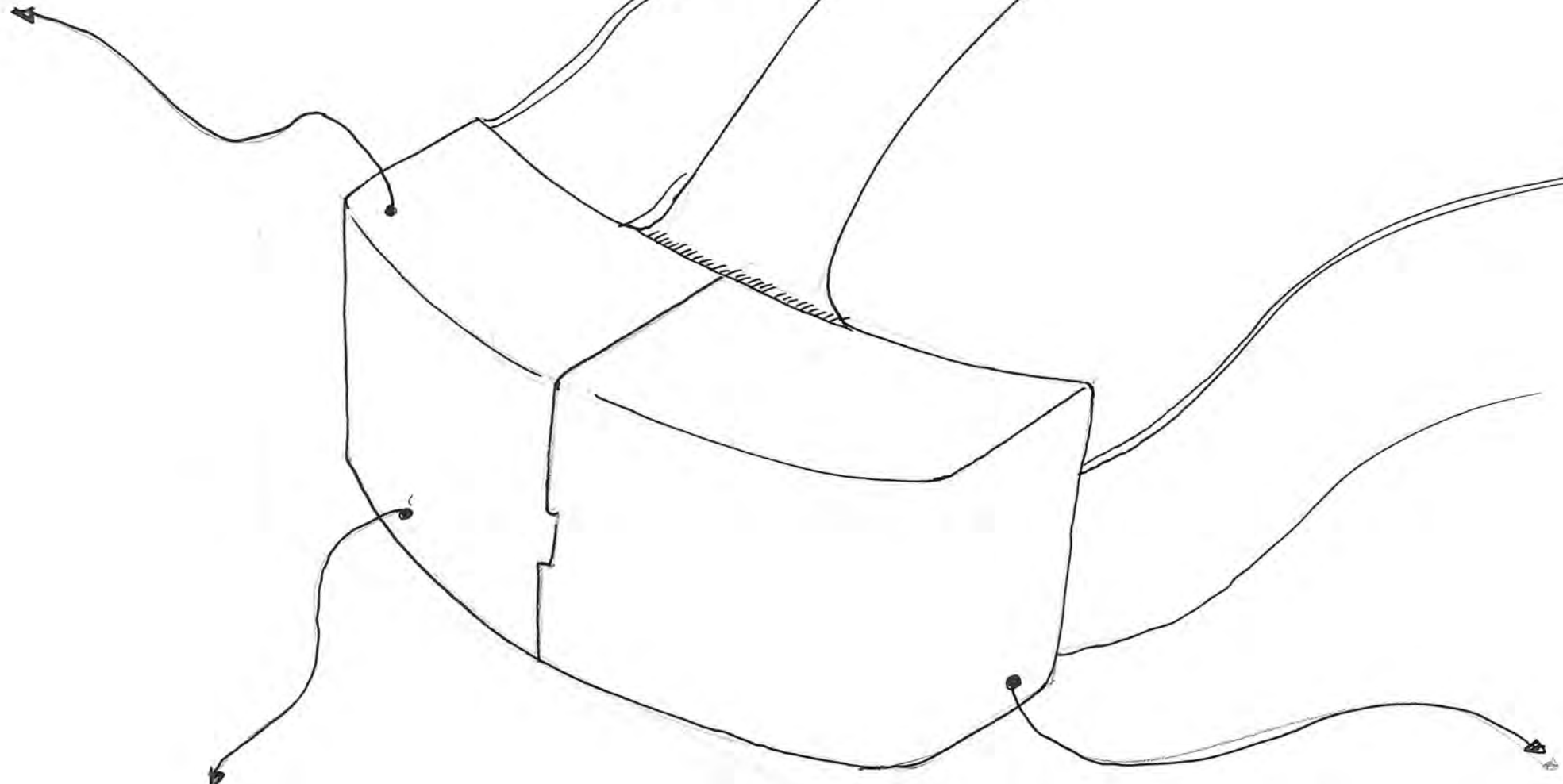

VR to reality

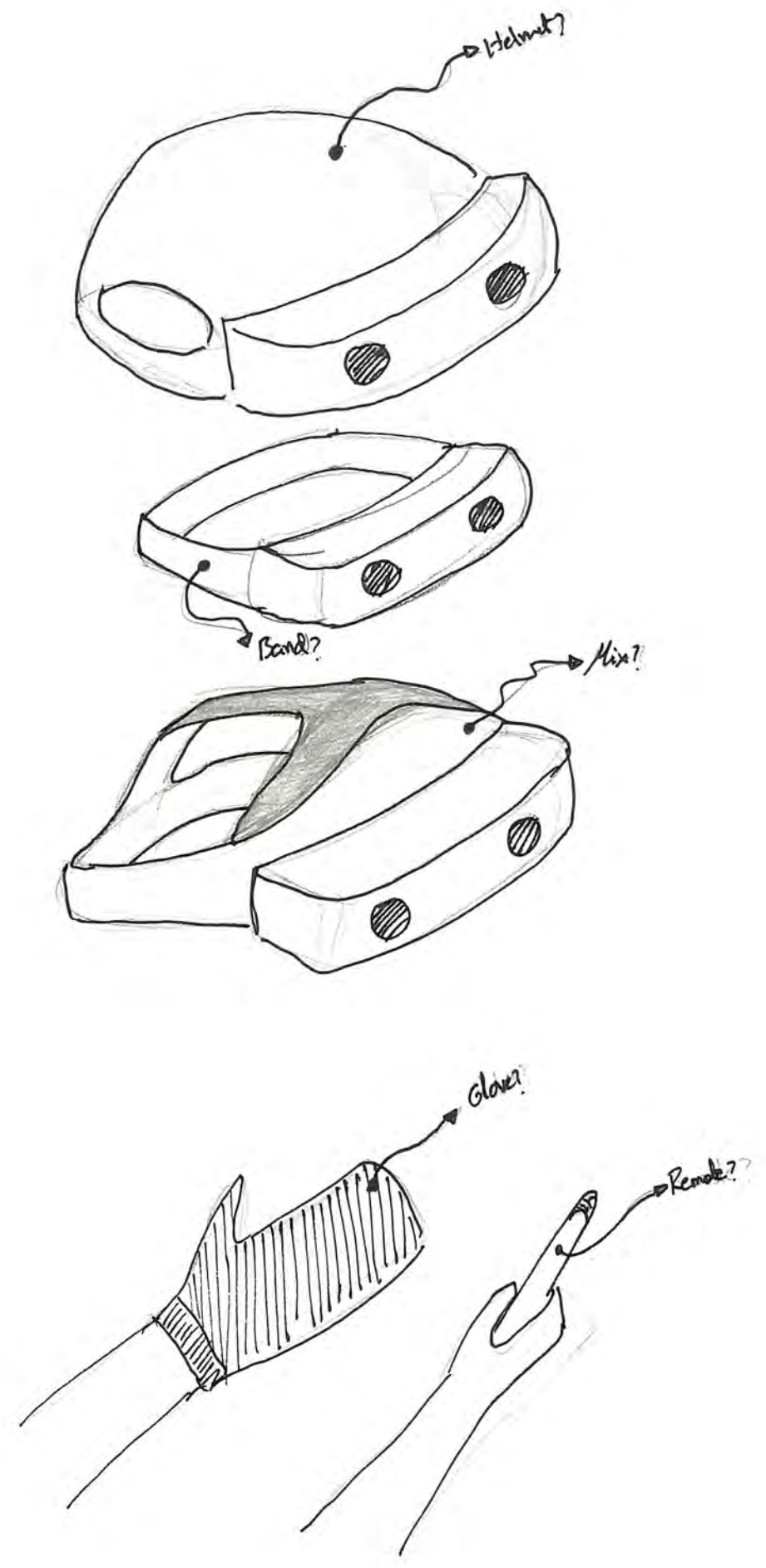
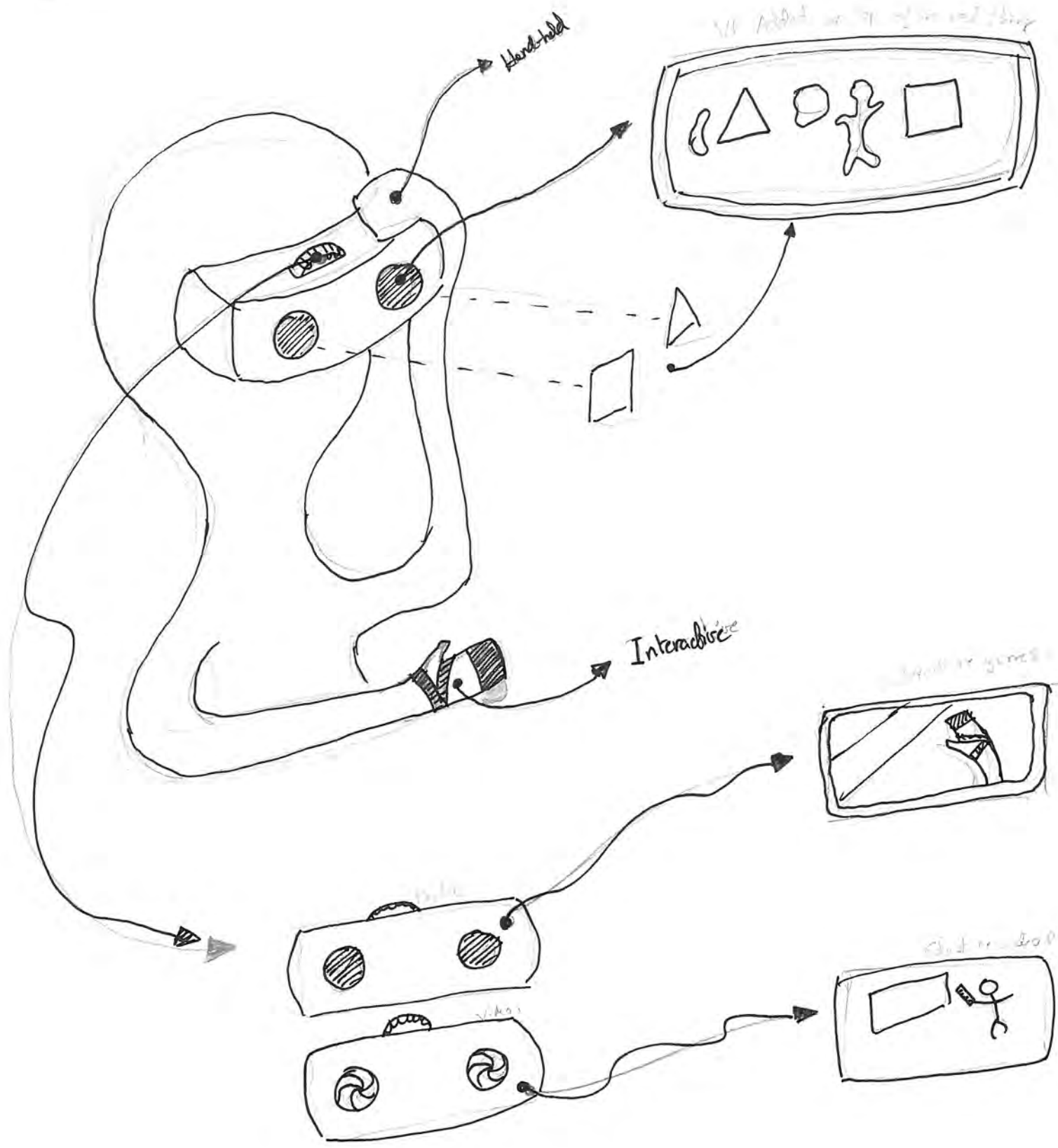

◆ Doctor
● Child

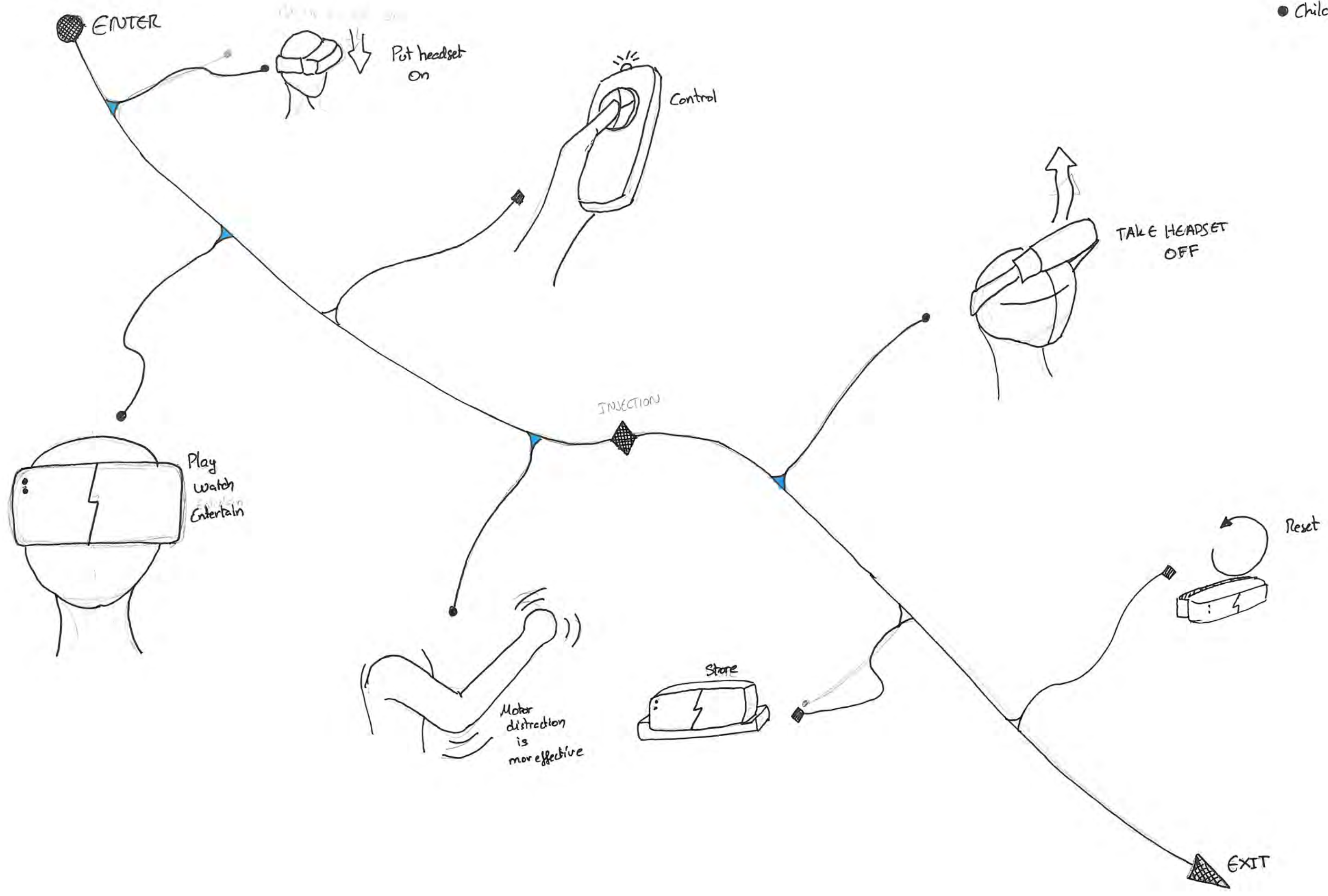

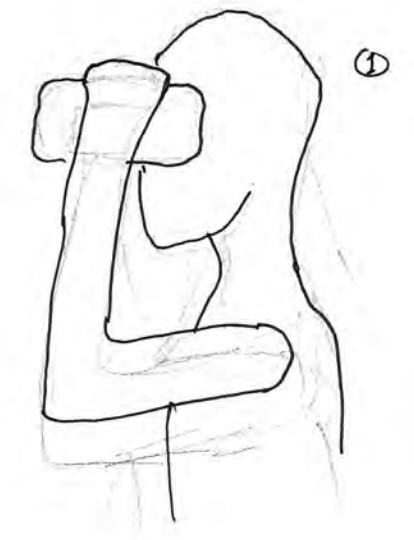
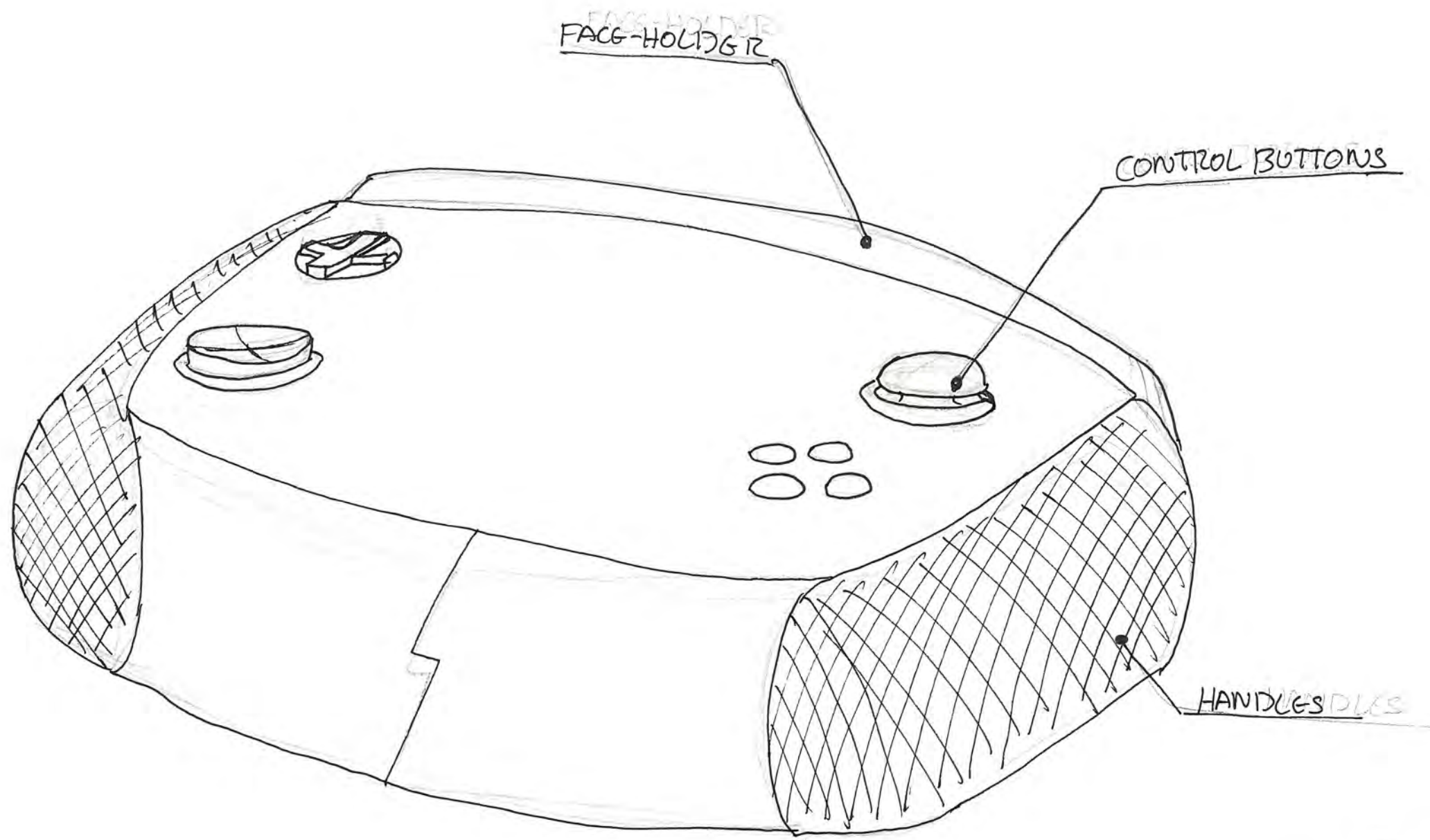

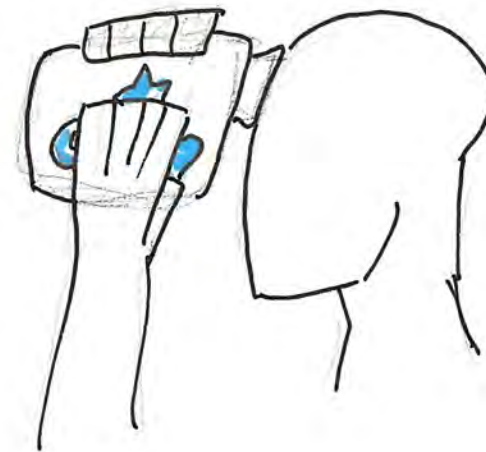
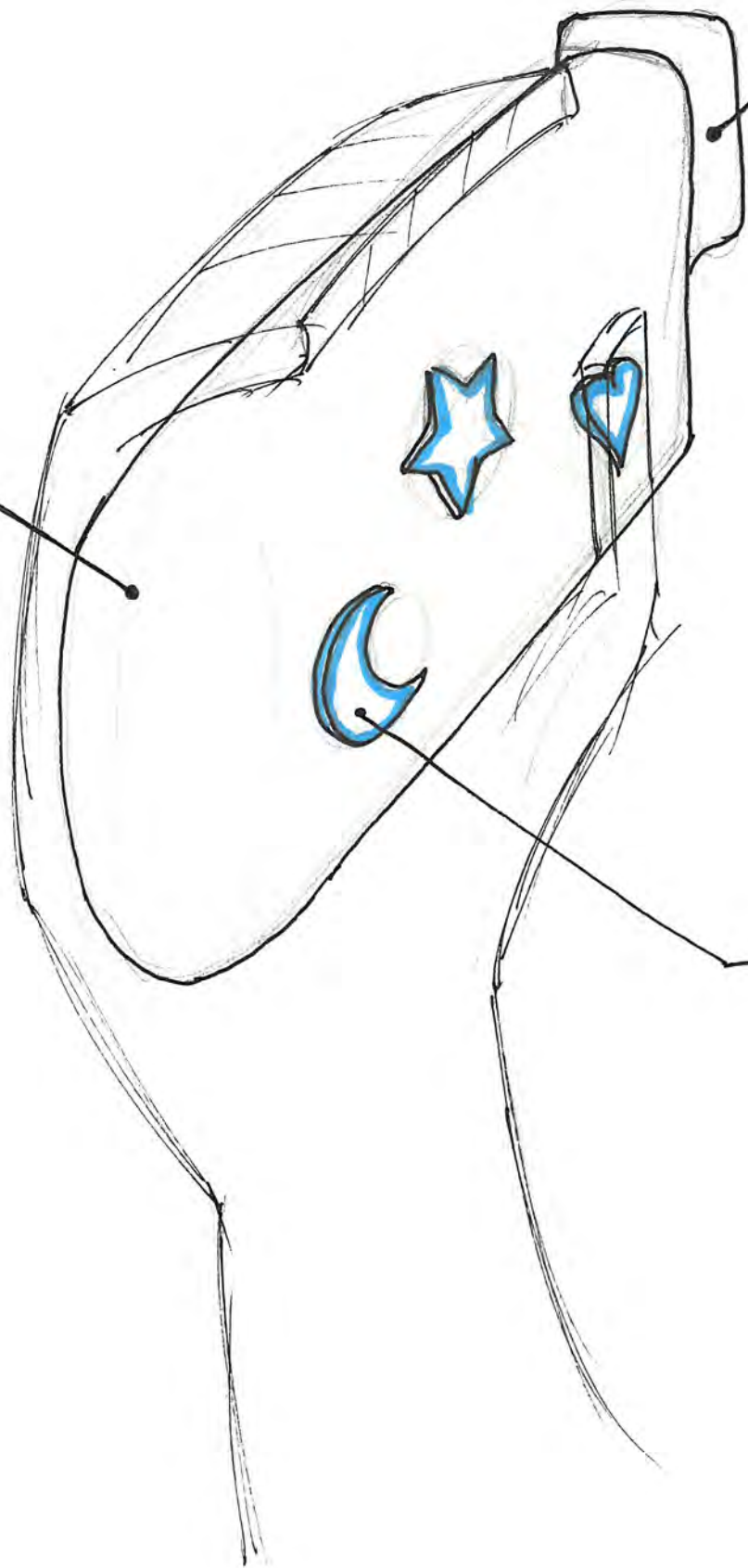
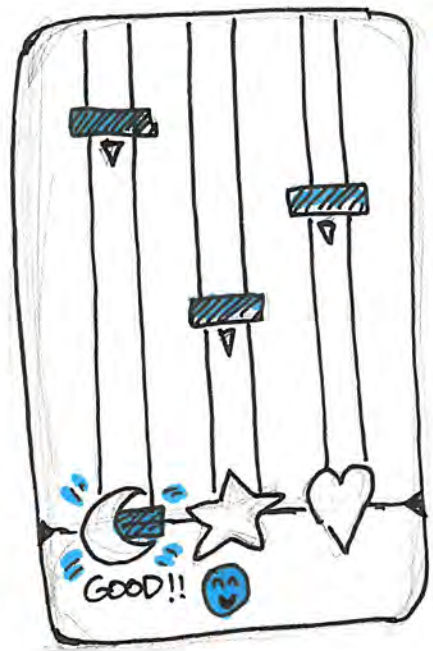

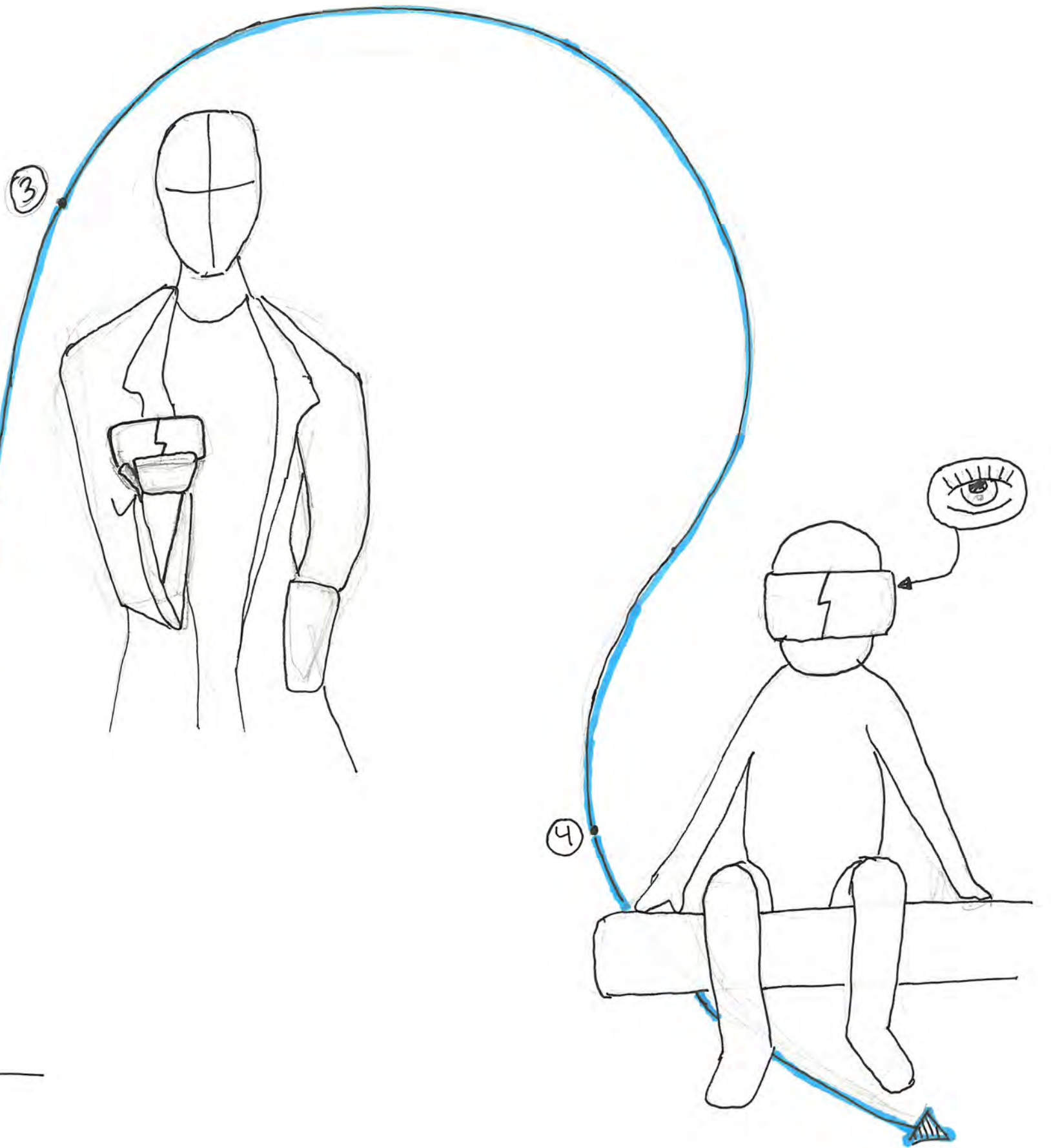
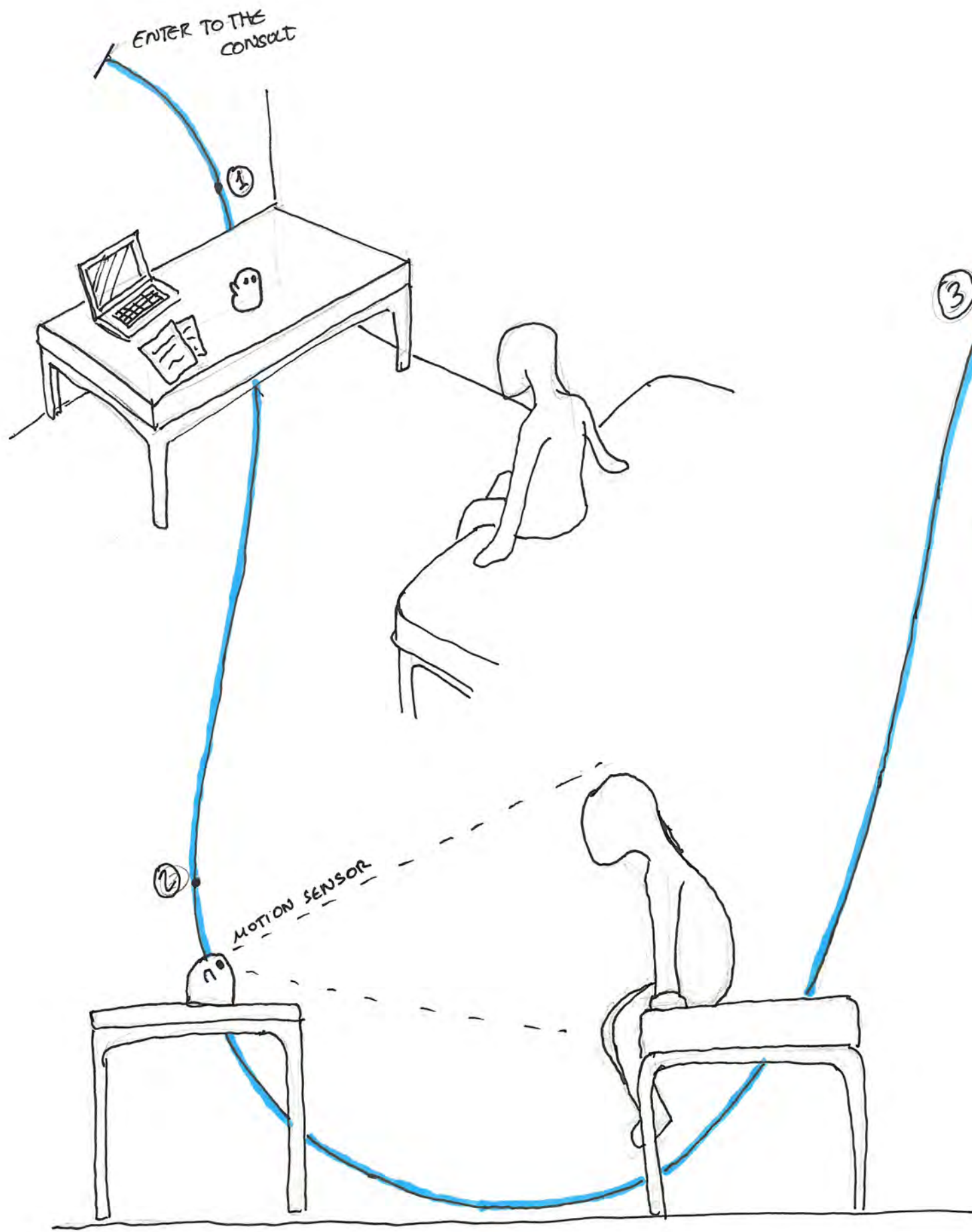

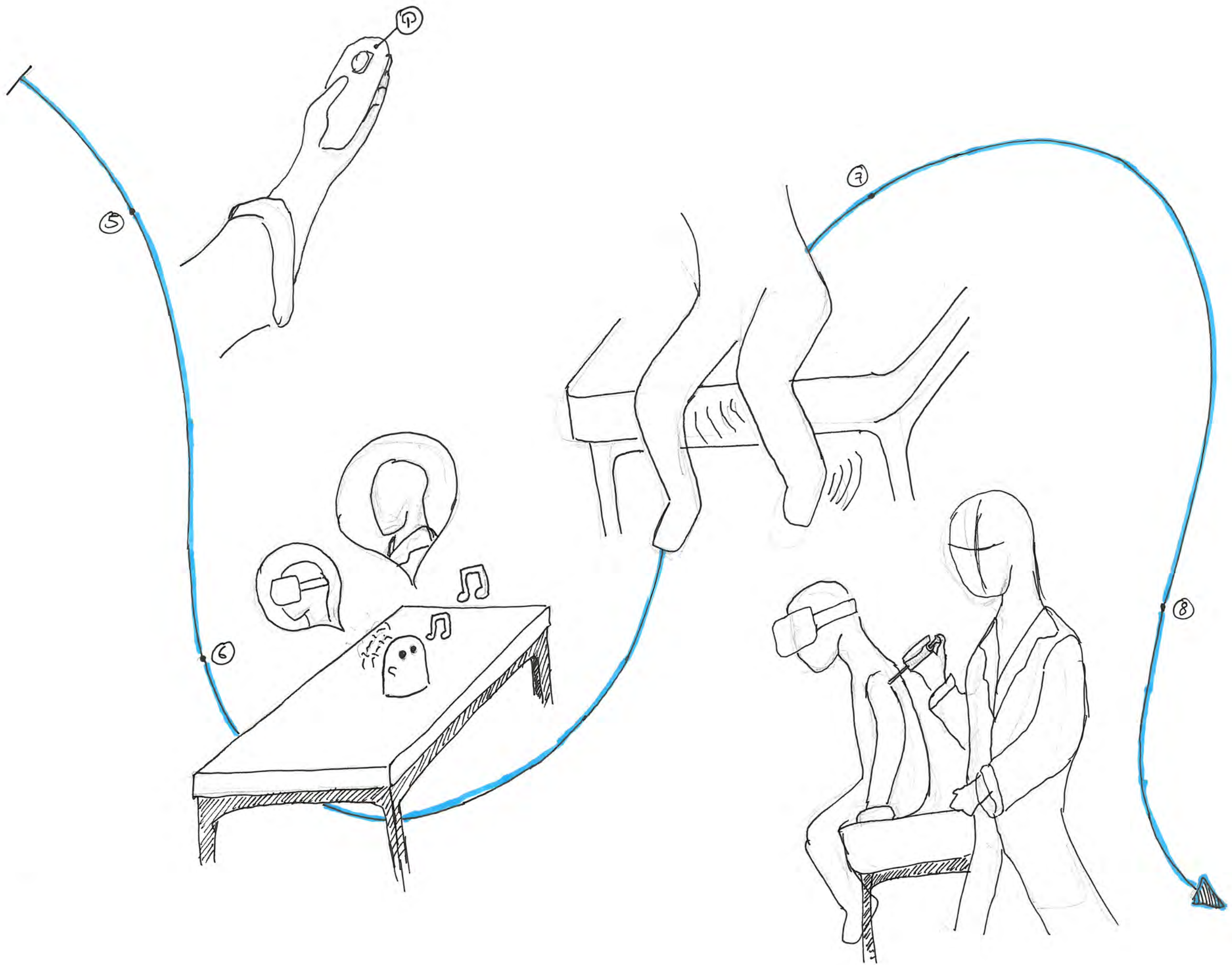

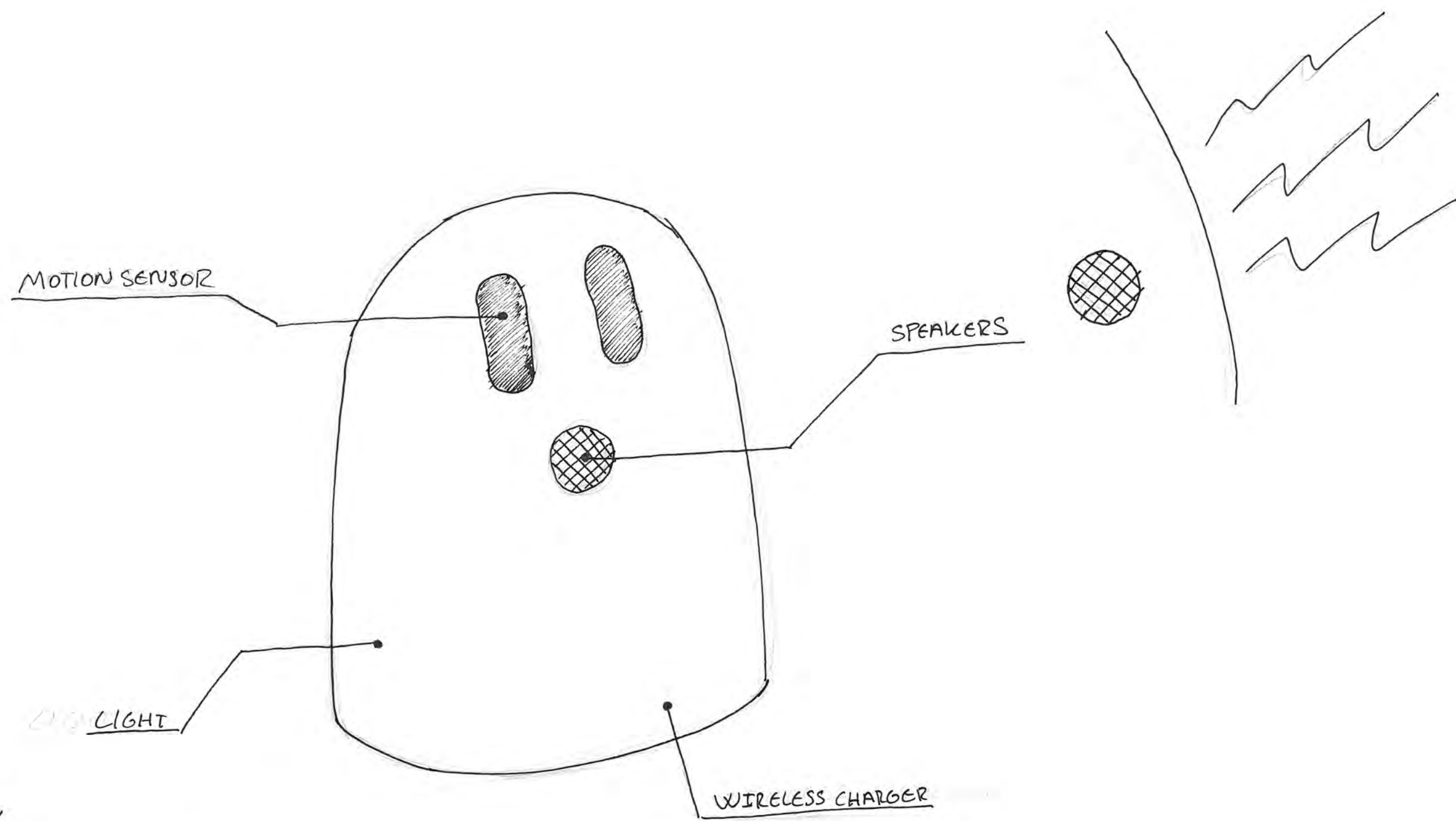

MOTION SENSOR

LIGHT

SPEAKERS

WIRELESS CHARGER

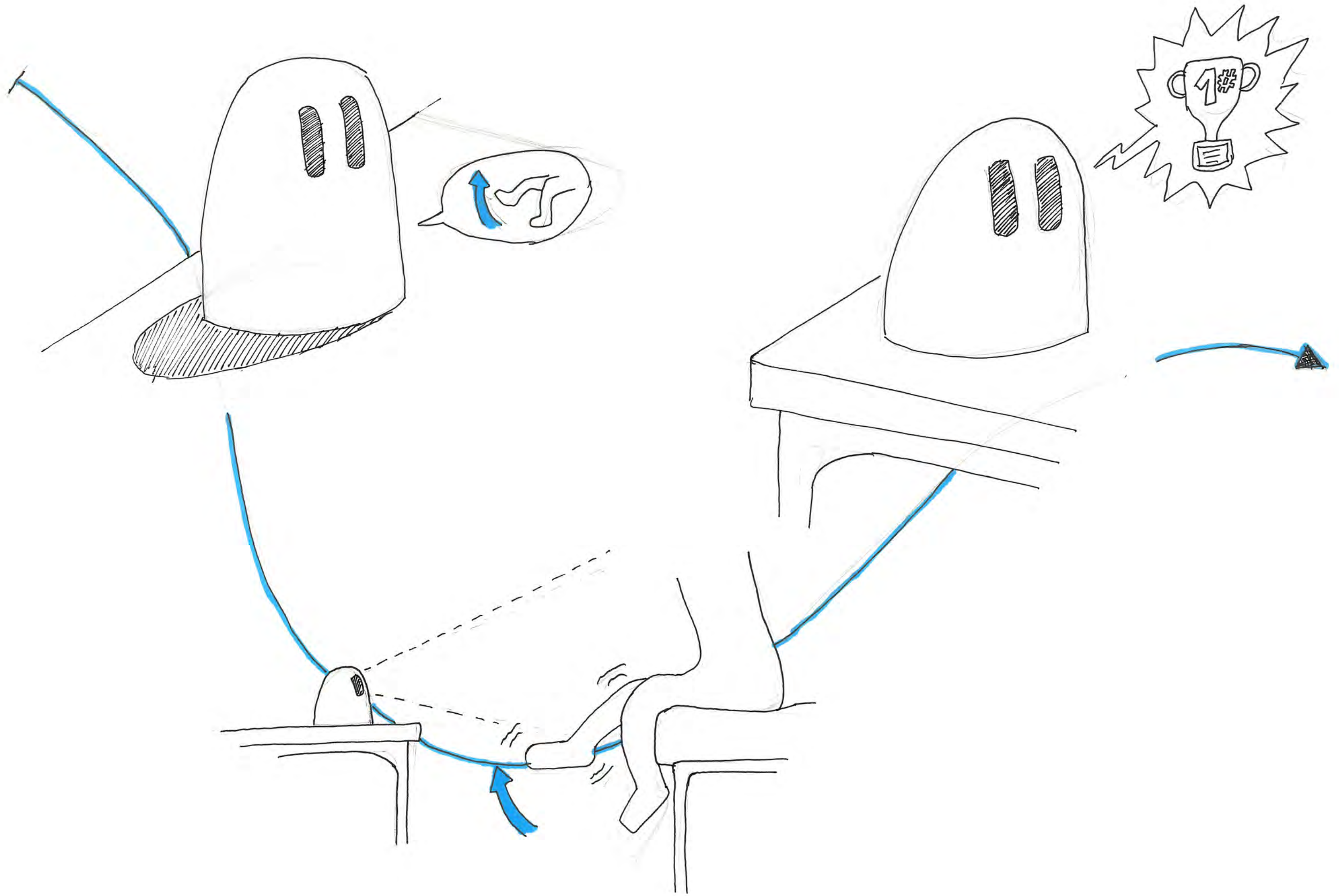

	HOLDING TOY	VR TOY	MOVEMENT SENSOR TOY	V/ACTOY WAITING ROOM
1/5				
PLACE	CONSULT	CONSULT/HOME	CONSULT	WAITING ROOM
INNOVATIVE	1	4	4	3
IMPACT	4	5	3	2
EXPOSURE TO THE PROCESS	1	1 / 5	1	4
PARENT INVOLVEMENT	2	2 / 4	1	4
EDUCATIVE	1	1 / 4	2	5
PRODUCT POTENTIAL	5	2	3	3
TOTAL	14	14 / 24	14	21

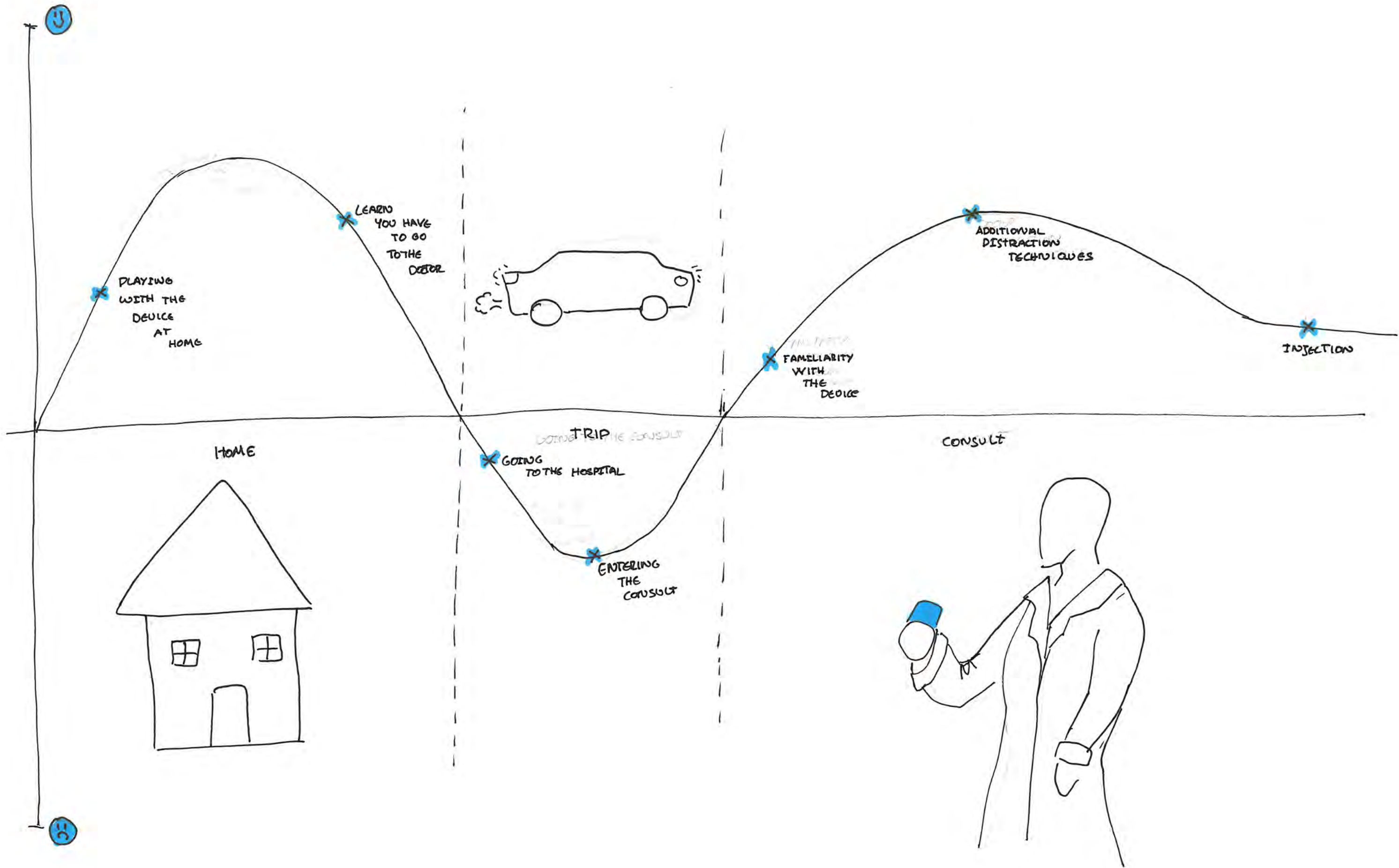

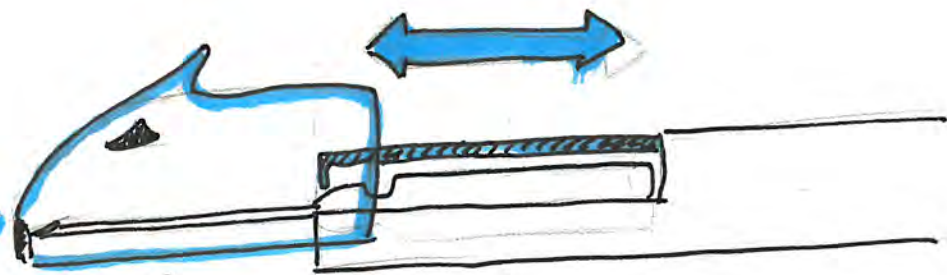
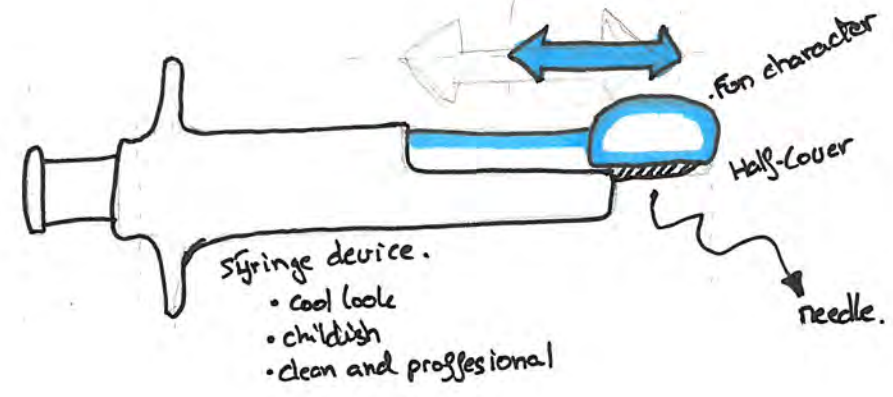
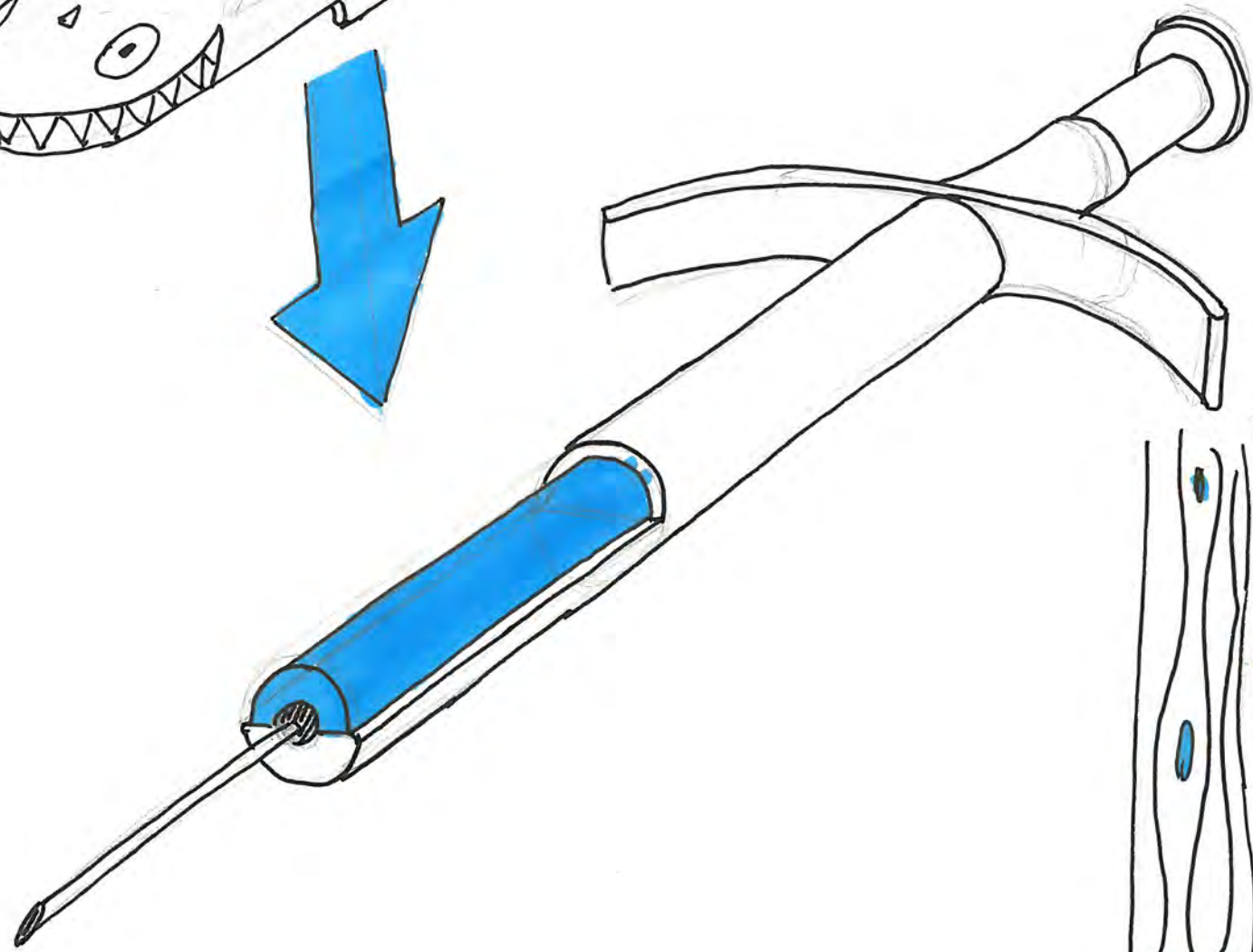
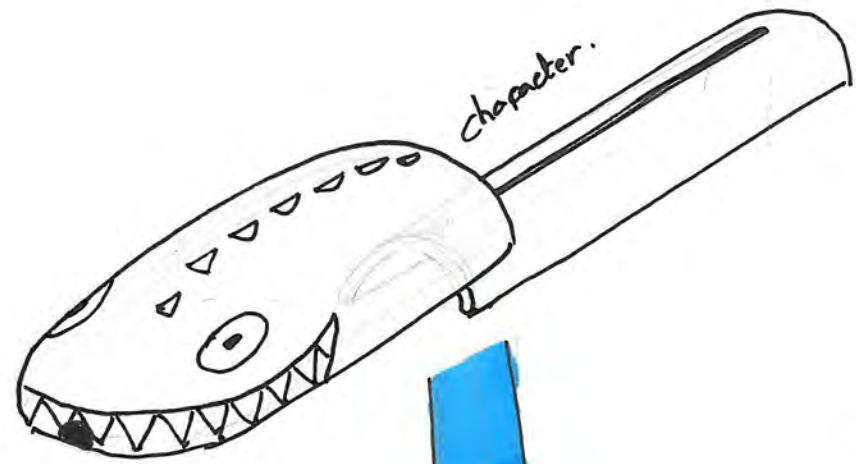

History
Poster
Collectible.
App?



ANNEX 4

Refining

Needle stamp toy

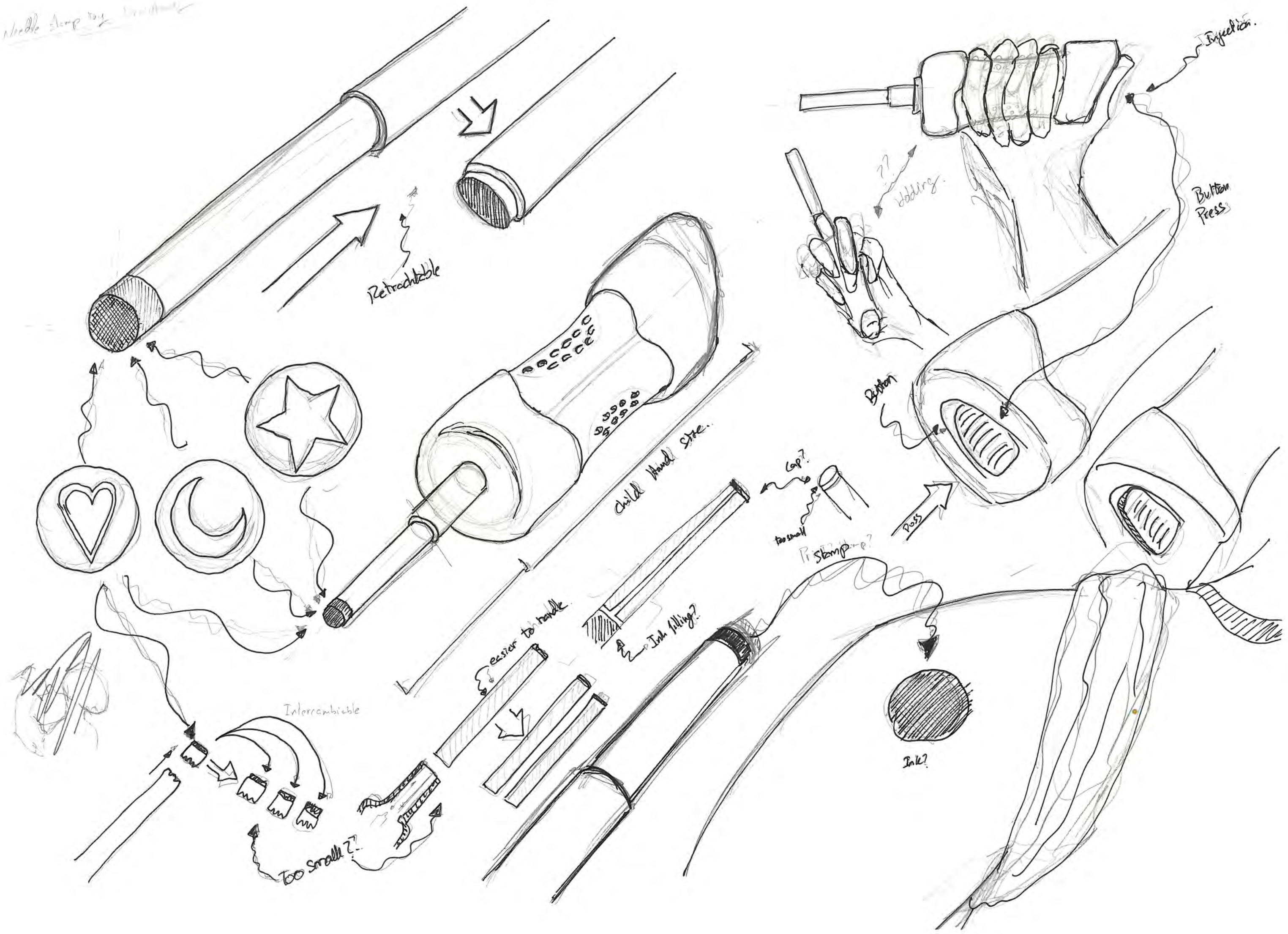

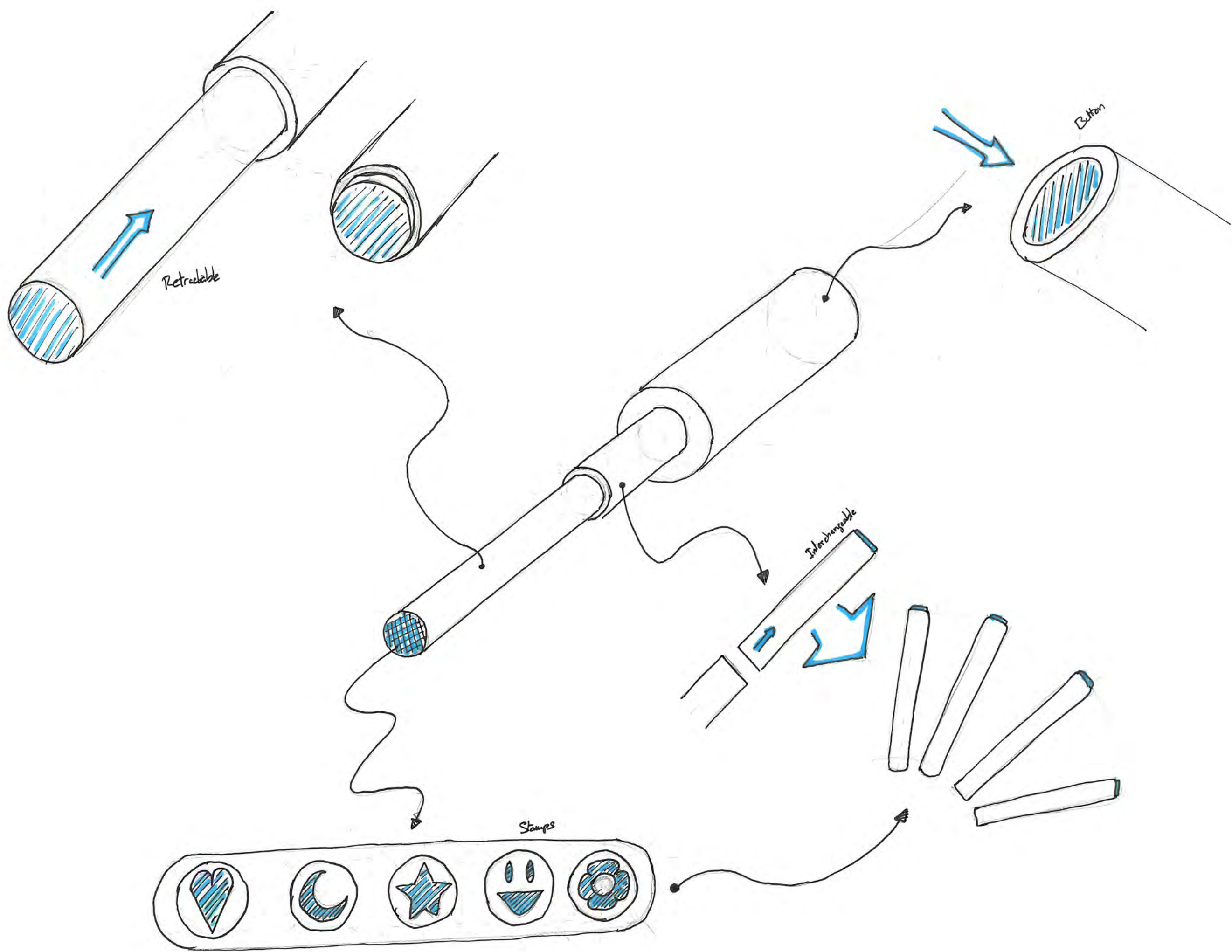

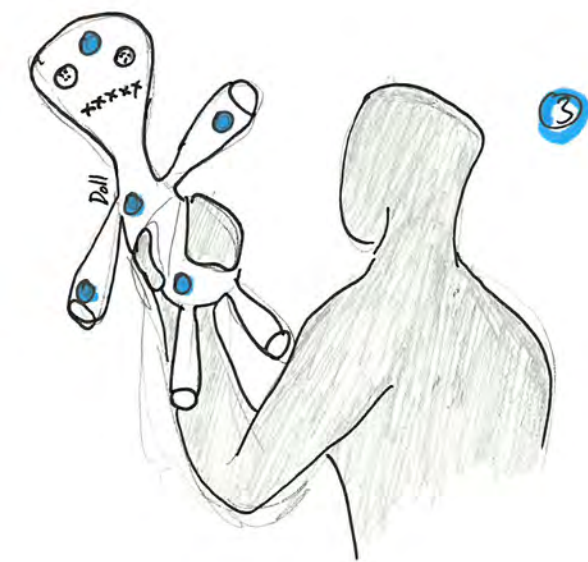
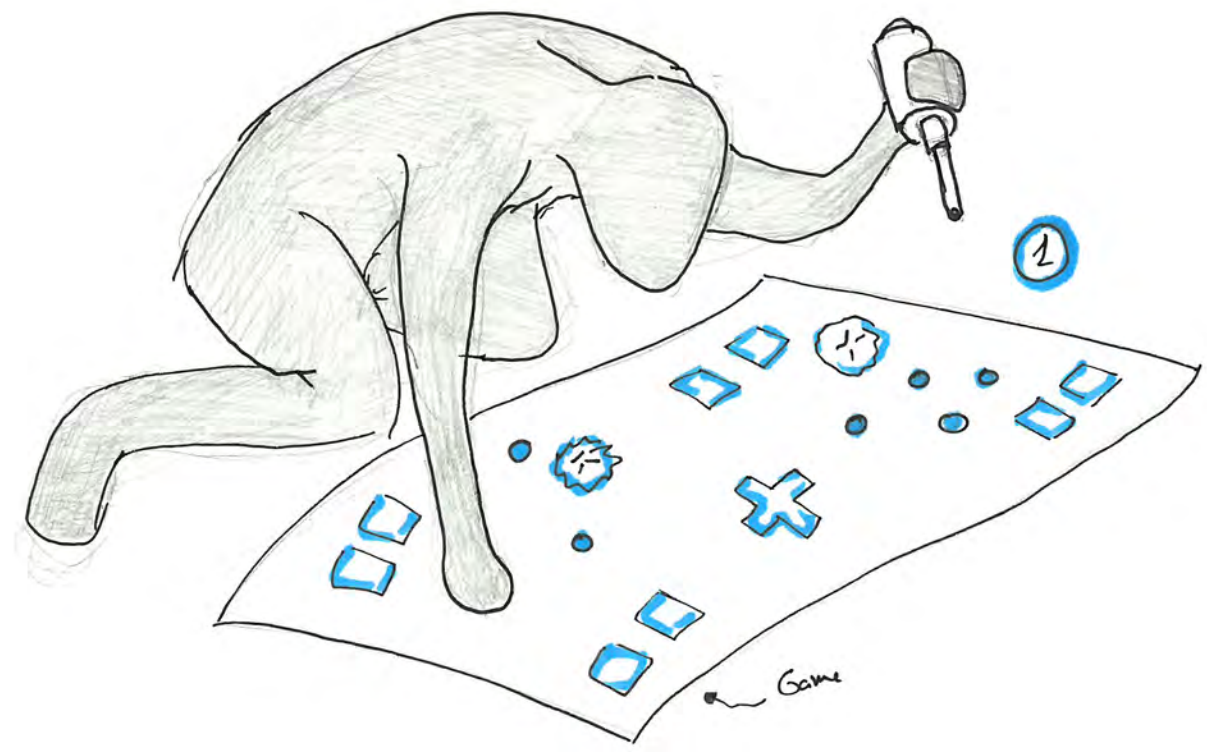
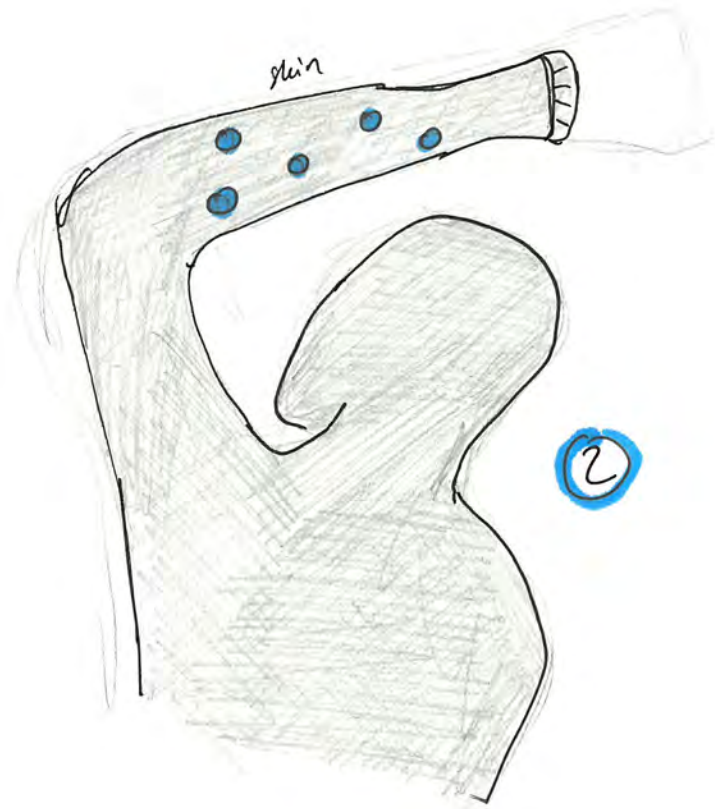

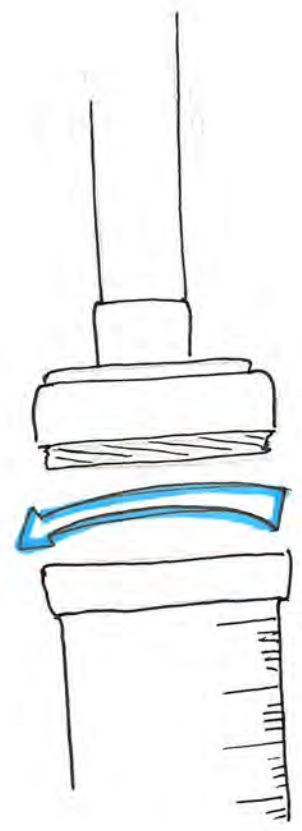

Refillable

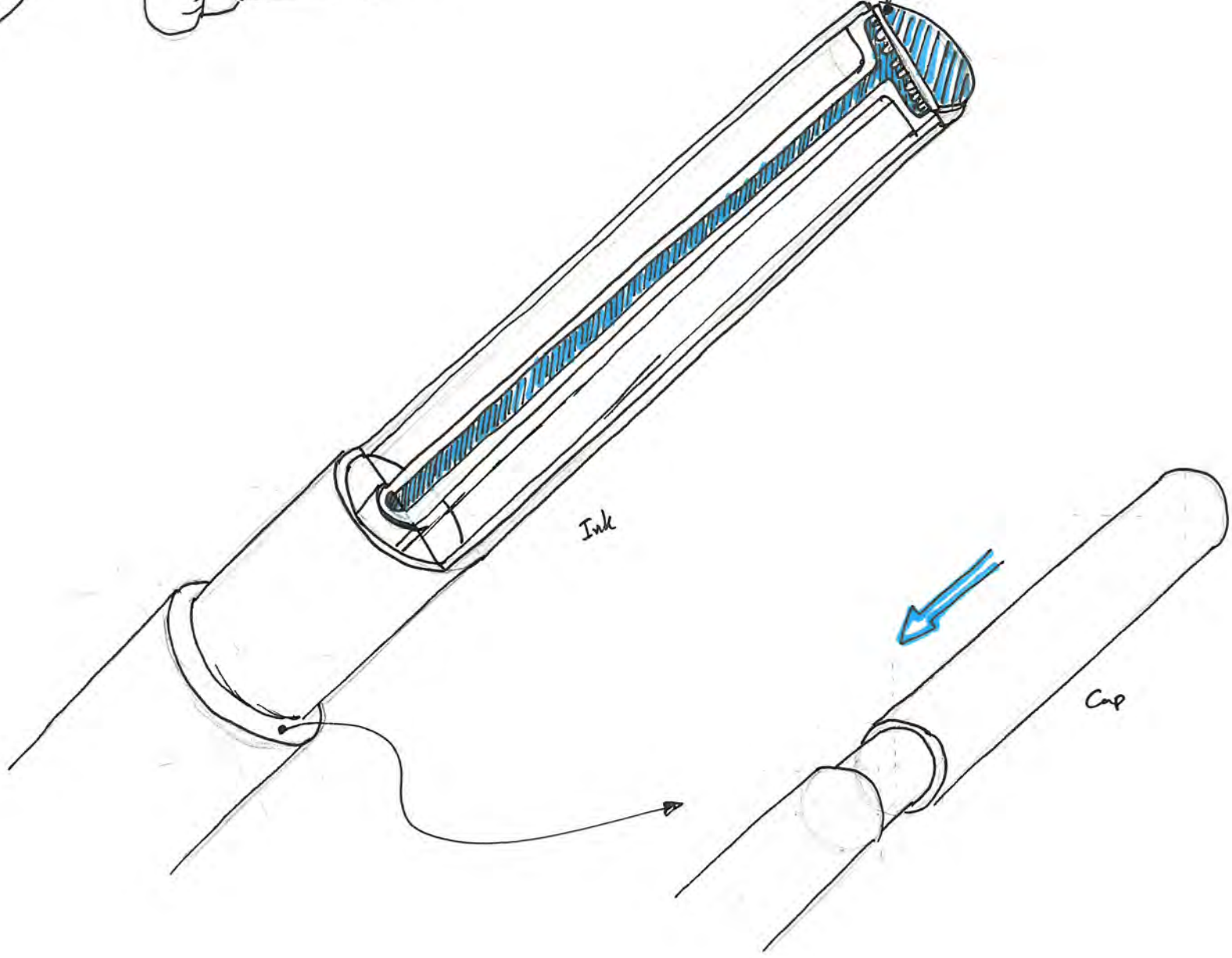
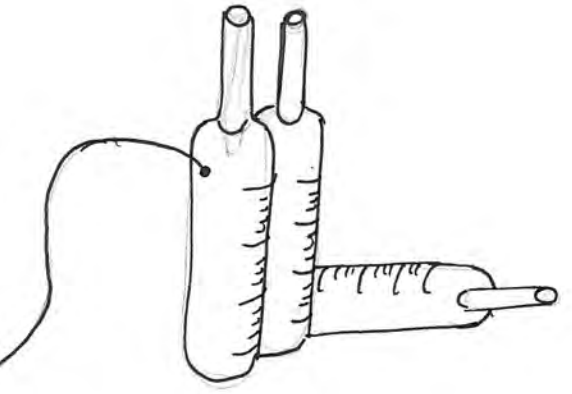

Ink

Cap

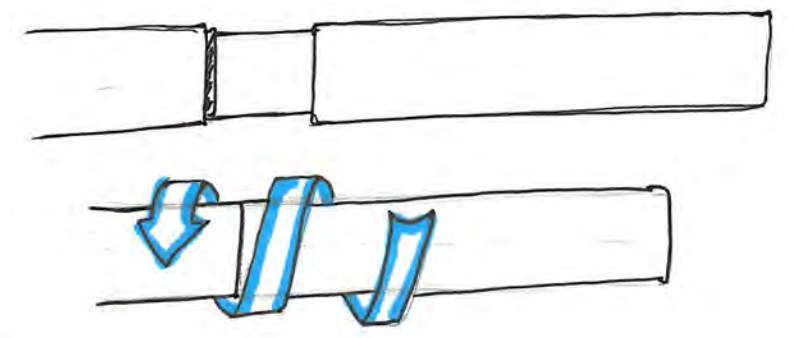
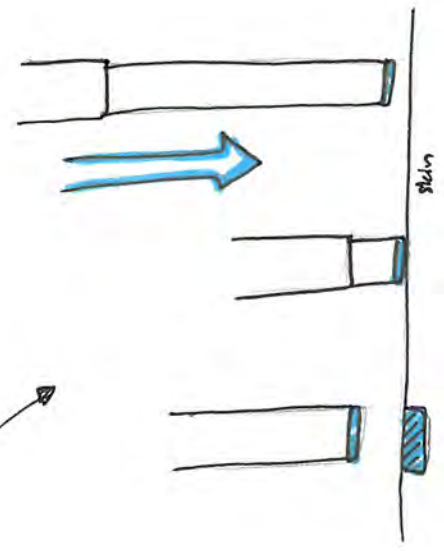

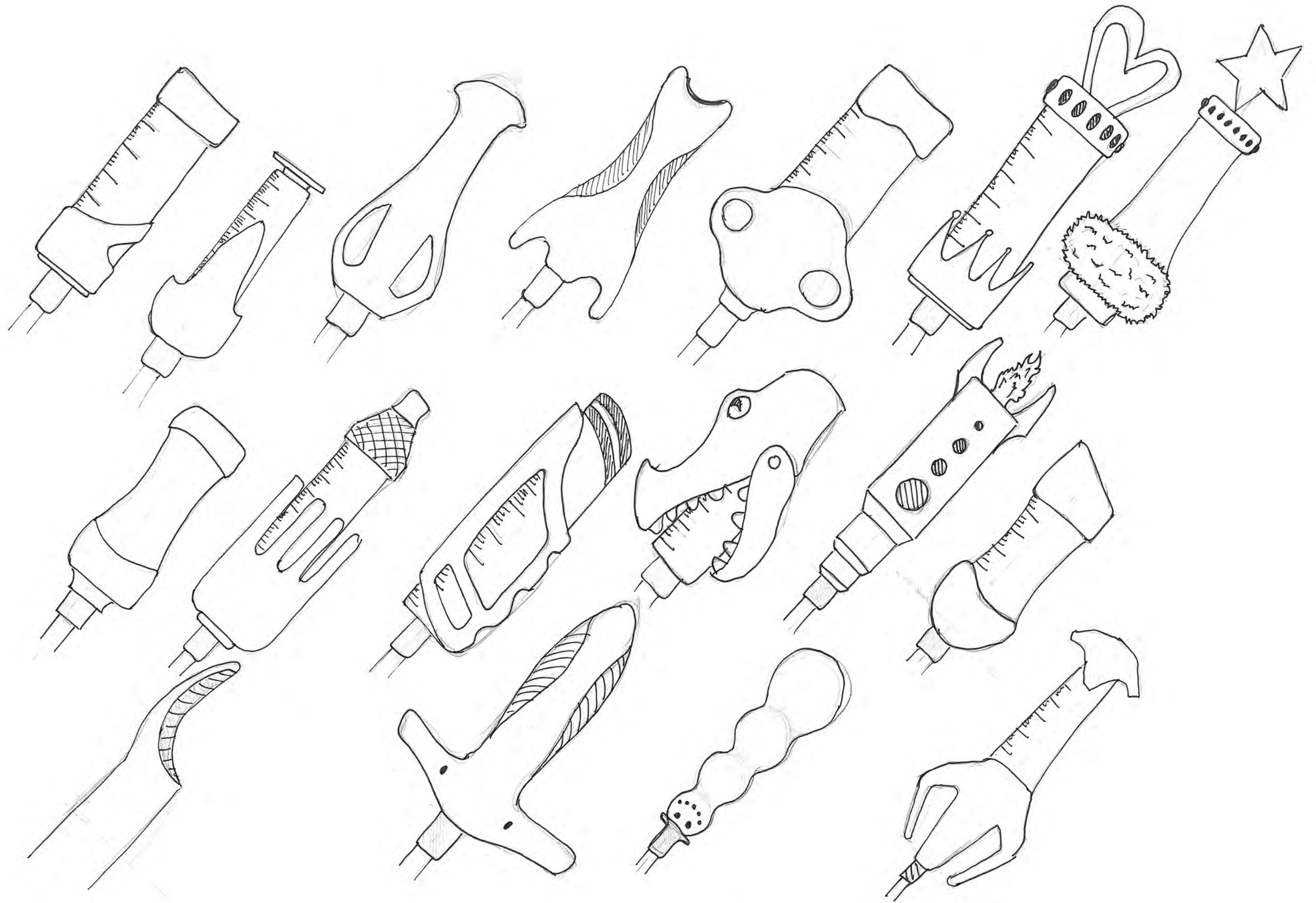

Children (Aged 3-10 Years)

The deltoid muscle is preferred for children aged 3-10 years (21); the needle length for deltoid site injections can range from 5/8 to 1 inch on the basis of technique. The anterolateral thigh can also be used (23). In this case the needle length should be 1 inch to 1.25 inches. Knowledge of body mass can be useful for estimating the appropriate needle length (24).



IIV	6-35 months: 0.25 mL or 0.5 mL ≥3 years: 0.5 mL 18-64 years: 0.1 mL
MenB	0.5 mL
MMR	0.5 mL
MMRV	0.5 mL
MenACWY	0.5 mL
MPSV4	0.5 mL
PCV13	0.5 mL
PPSV23	0.5 mL
HPV	0.5 mL
IPV	0.5 mL
DTaP, DT, Td, Tdap	0.5 mL
DTaP-HepB-IPV	0.5 mL
DTaP/Hib	0.5 mL
DTaP-IPV/Hib	0.5 mL
DTaP-IPV	0.5 mL
Hib	0.5 mL
Hib-MenCY	0.5 mL
HepA	≤18 years: 0.5 mL ≥19 years: 1.0 mL
HepB	≤19 years: 0.5 mL ^(a) ≥20 years: 1.0 mL

Children, 3-10 years

5/8^(b)-1 inch (16-25 mm)
1-1.25 inches (25-32 mm)

Deltoid muscle of arm^(c)
Anterolateral thigh

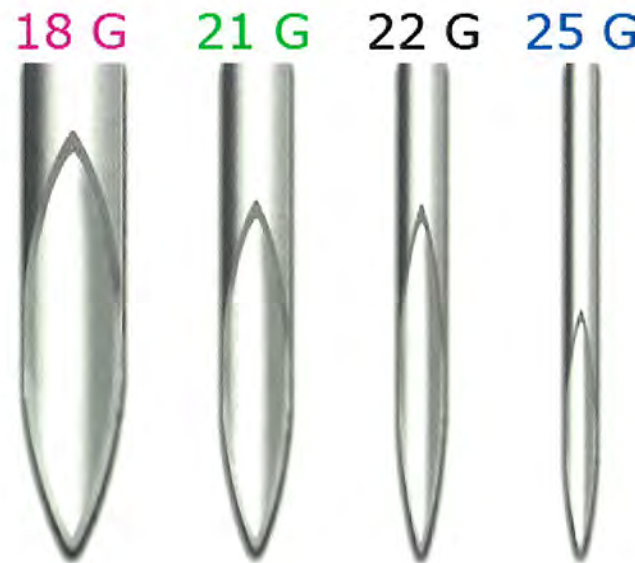
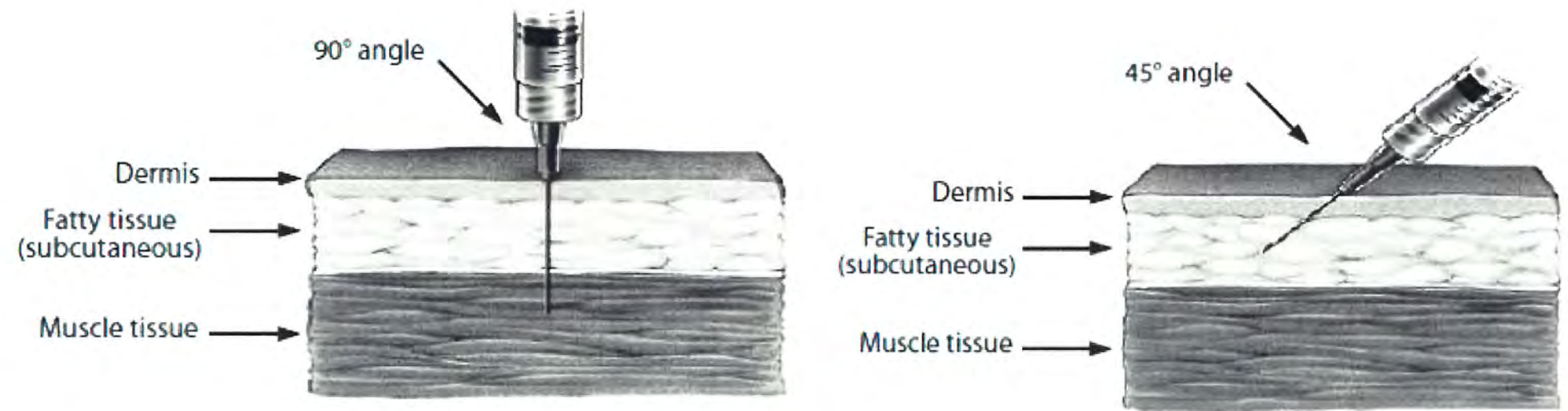

22	0.02825	0.7176	±0.00025 (±0.0064)	0.01625	0.413	±0.00075 (±0.019)	0.006	0.1524	±0.00025 (±0.0064)	Black
22s	0.02825	0.7176	±0.00025 (±0.0064)	0.006	0.152	±0.00075 (±0.019)	0.0111	0.2826	±0.00025 (±0.0064)	
23	0.02525	0.6414	±0.00025 (±0.0064)	0.01325	0.337	±0.00075 (±0.019)	0.006	0.1524	±0.00025 (±0.0064)	Deep blue
24	0.02225	0.5652	±0.00025 (±0.0064)	0.01225	0.311	±0.00075 (±0.019)	0.005	0.1270	±0.00025 (±0.0064)	Medium purple
25	0.02025	0.5144	±0.00025 (±0.0064)	0.01025	0.260	±0.00075 (±0.019)	0.005	0.1270	±0.00025 (±0.0064)	Orange
26	0.01825	0.4636	±0.00025 (±0.0064)	0.01025	0.260	±0.00075 (±0.019)	0.004	0.1016	±0.00025 (±0.0064)	Brown
26s	0.01865	0.4737	±0.00025 (±0.0064)	0.005	0.127	±0.00075 (±0.019)	0.0068	0.1734	±0.00025 (±0.0064)	

Fine gauge needles offer less pain for the patient.

22-25 G needles are used in vaccination

CONCEPT

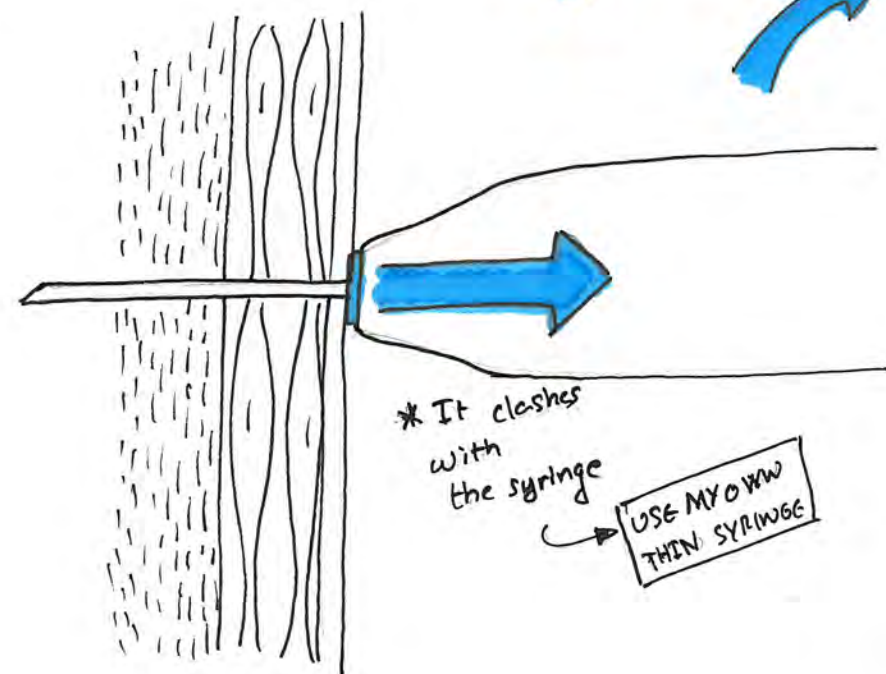
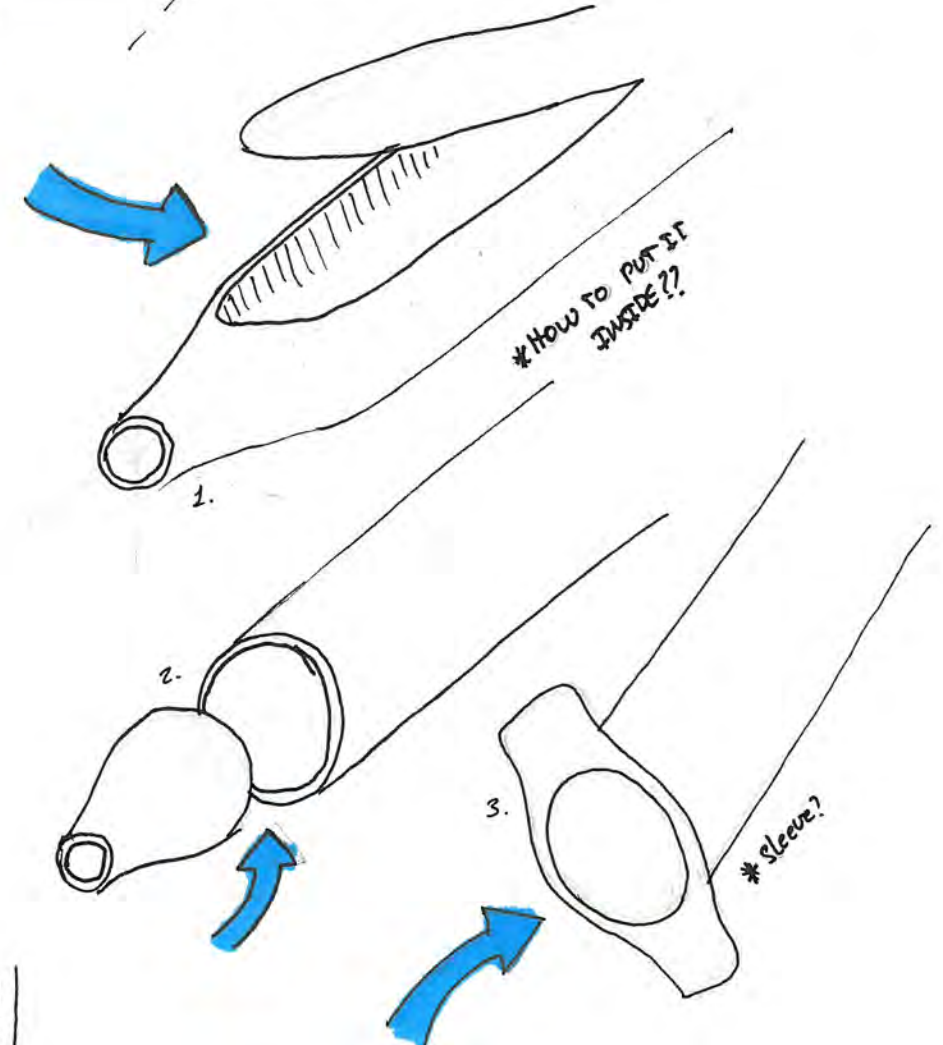
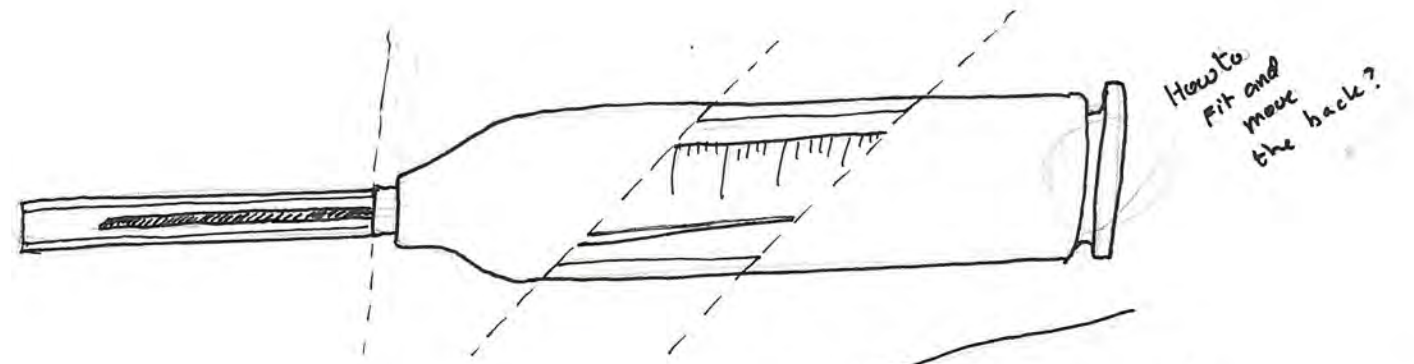
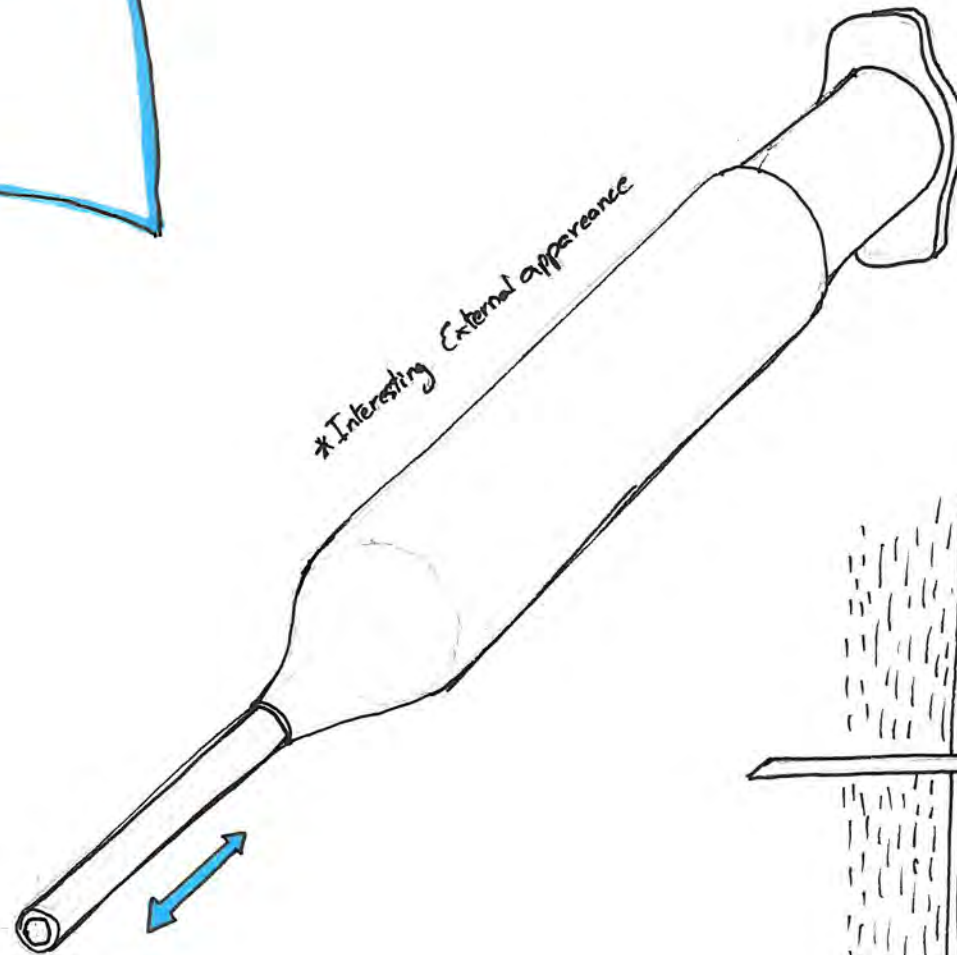
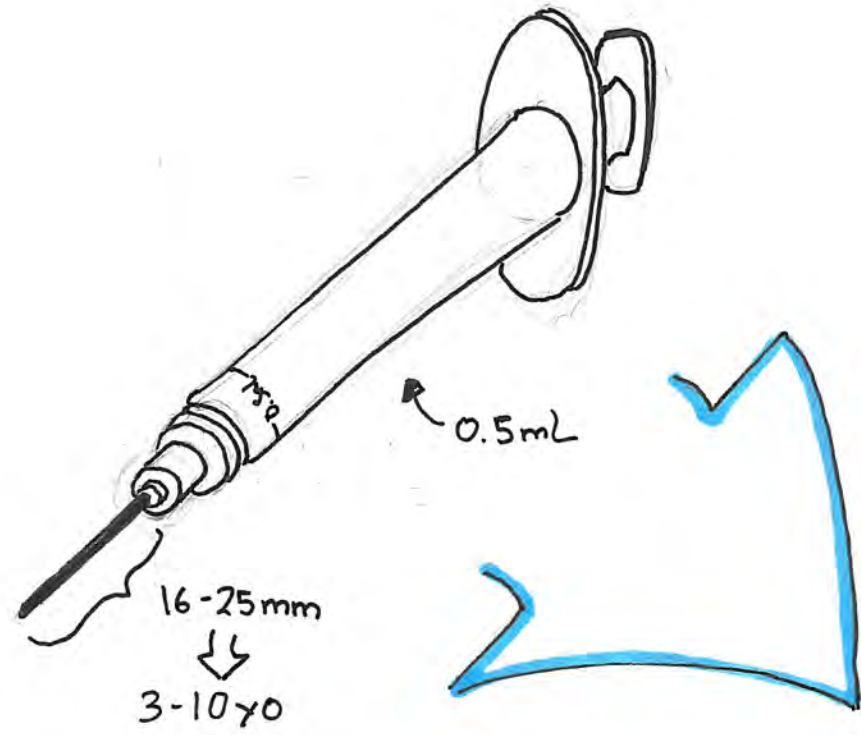

2 # SOLUTION

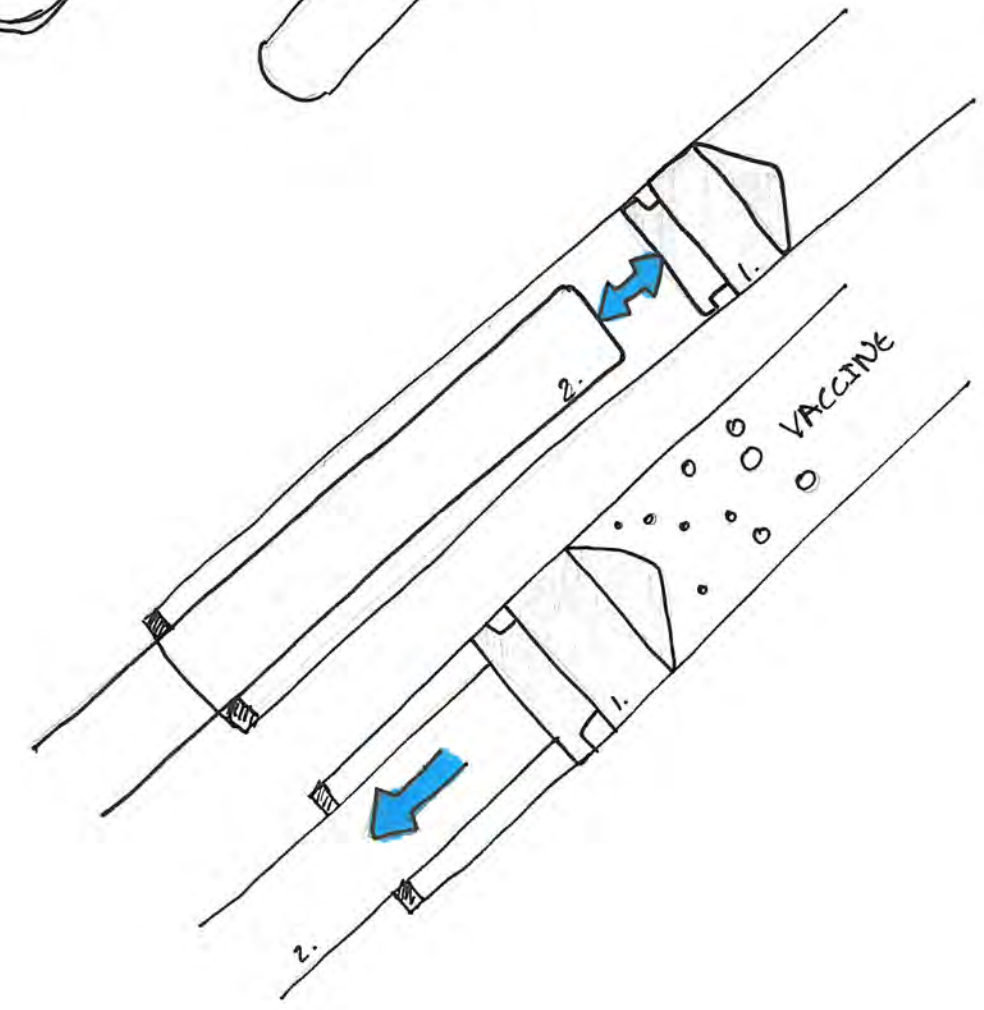
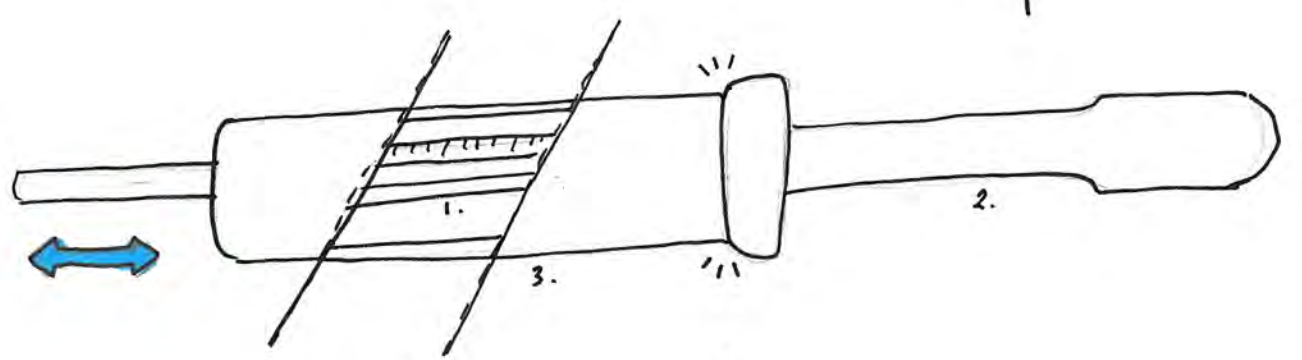
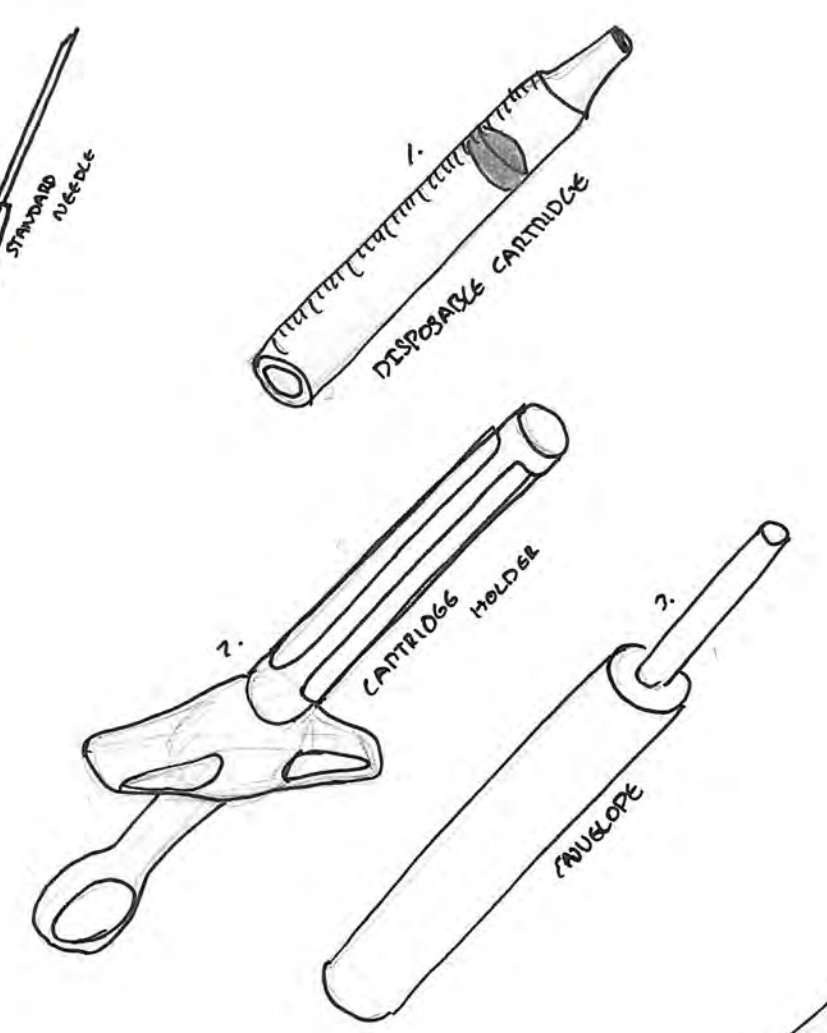
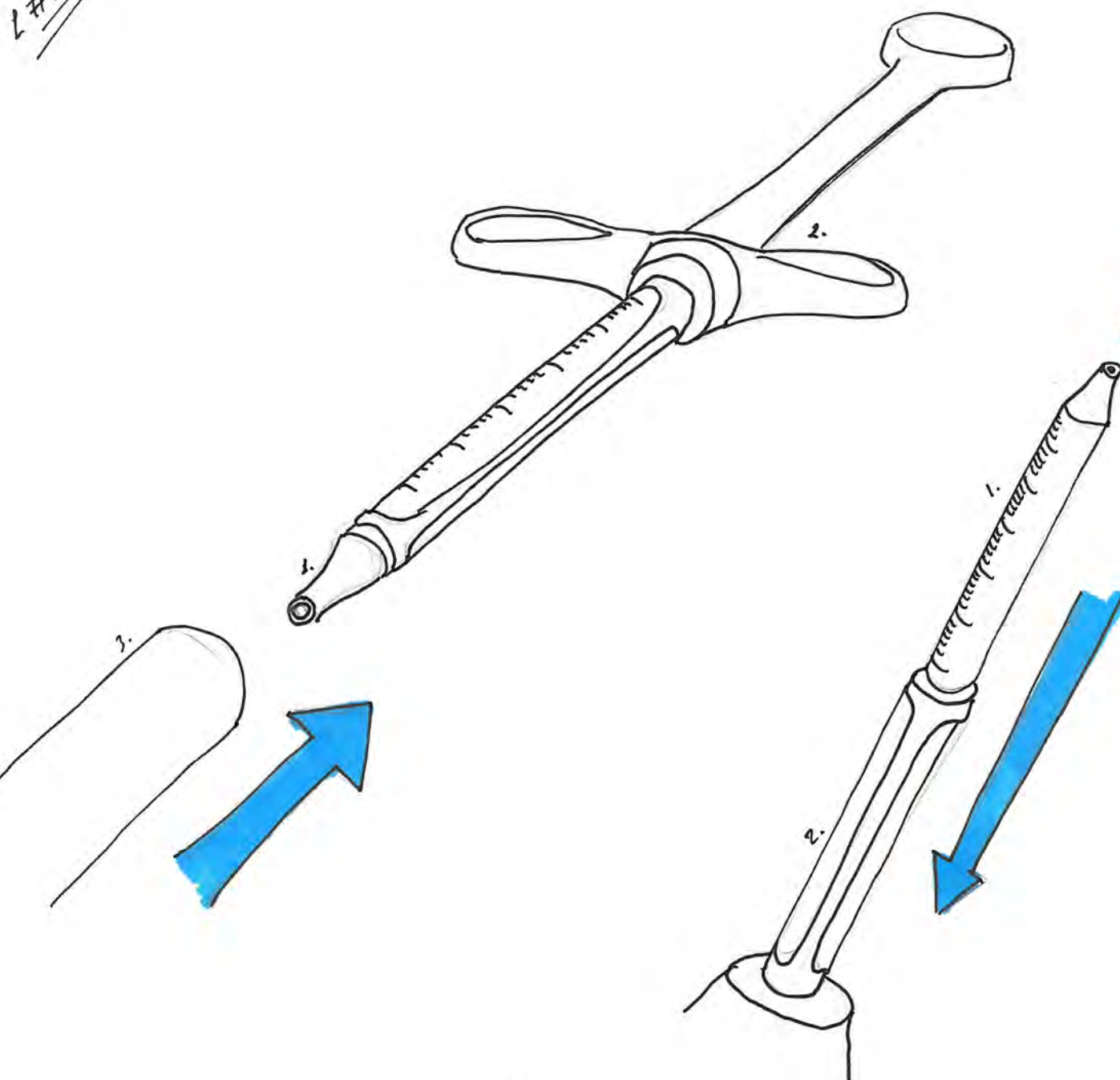

- * Easy to use
- * Easy to prepare
- * Intuitive
- * Cheap

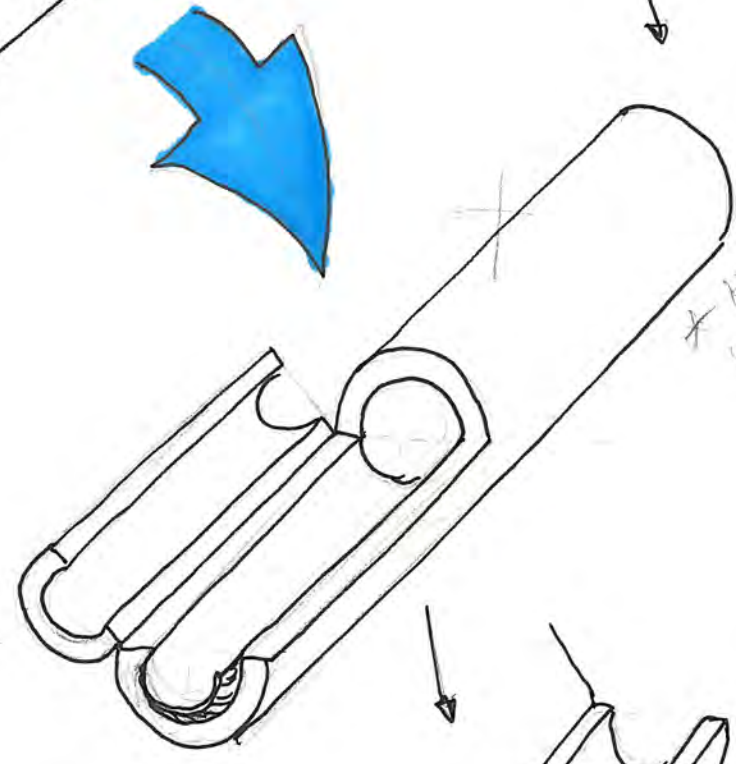
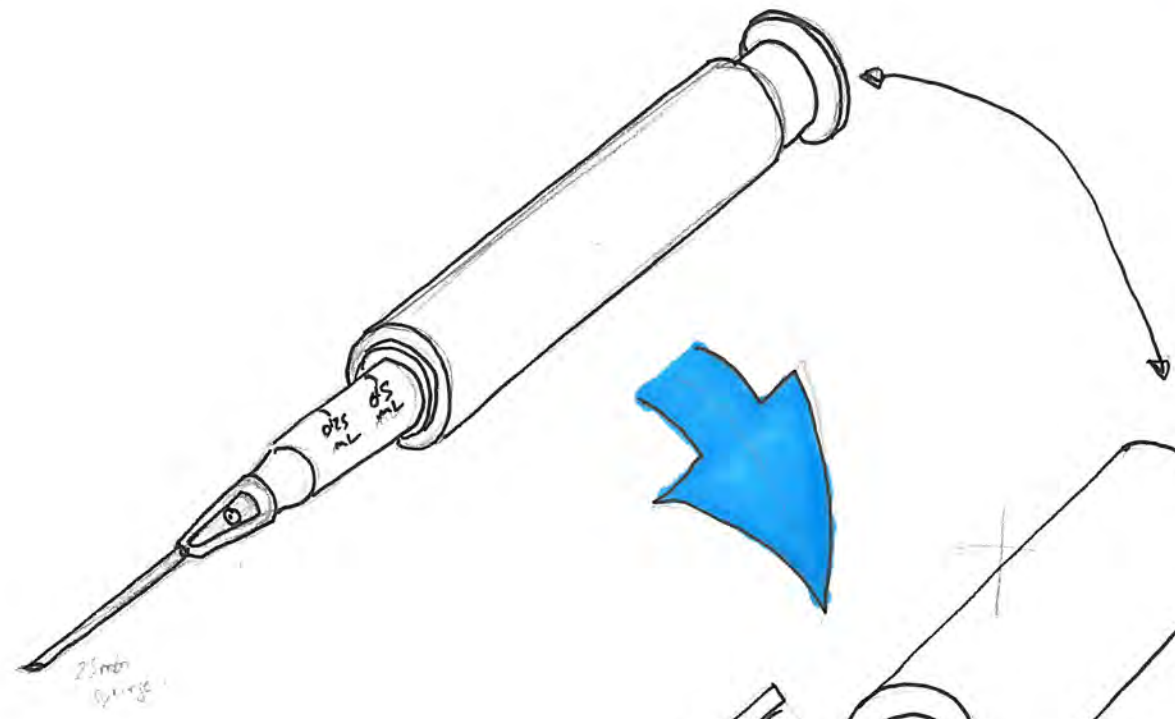
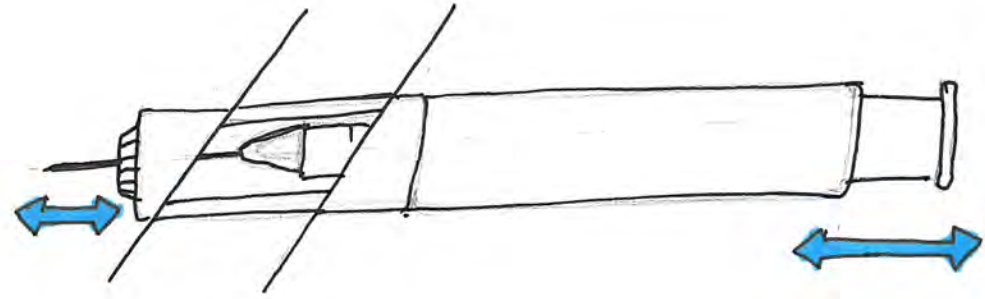

* How would THIS FUNCTION AS A CHILD TOY

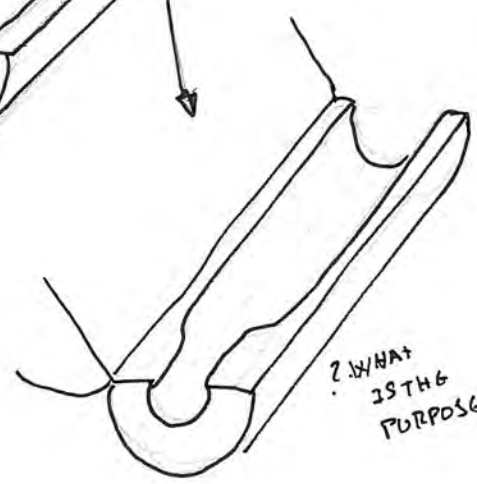

? WHAT IS THE PURPOSE?

PRESET DIAMETERS
STAN DILATOR

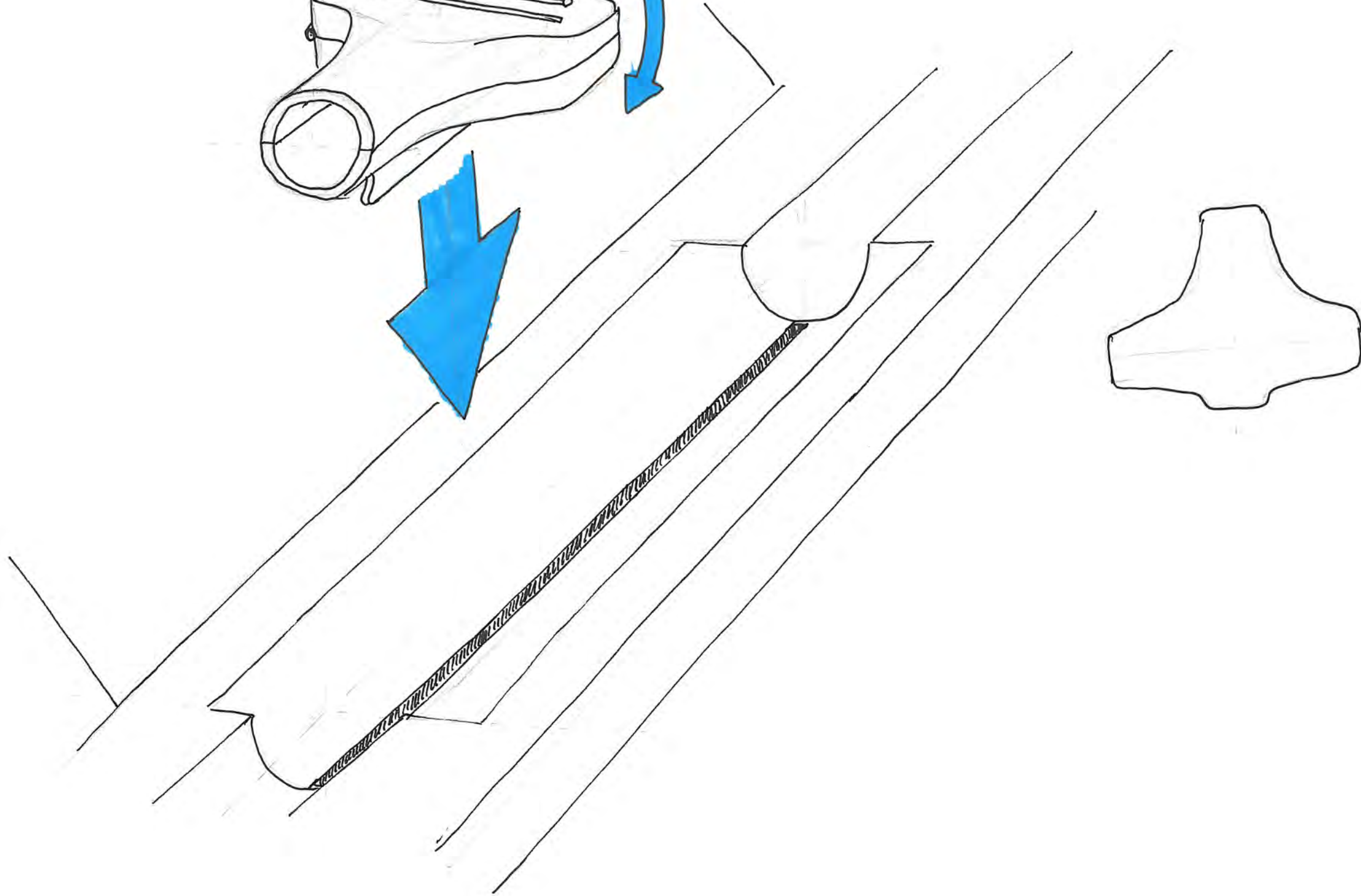
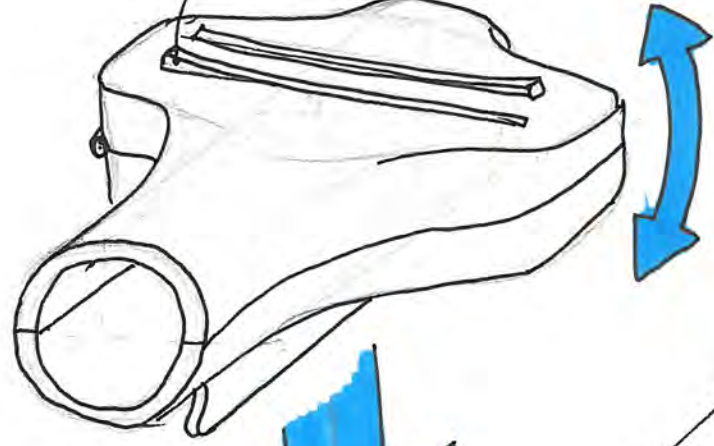
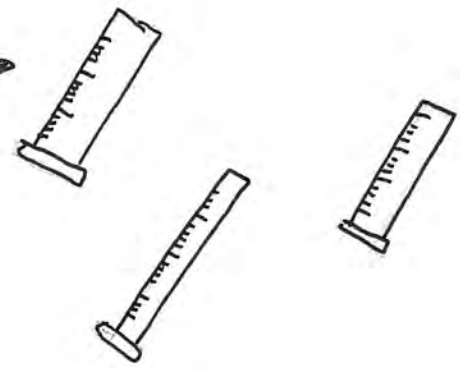
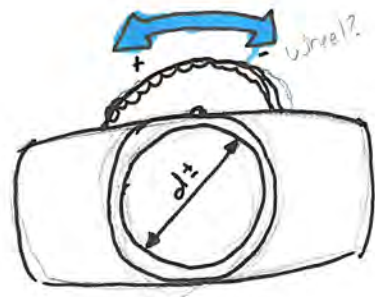

Home-vaccino??

V = n · Redio? A-

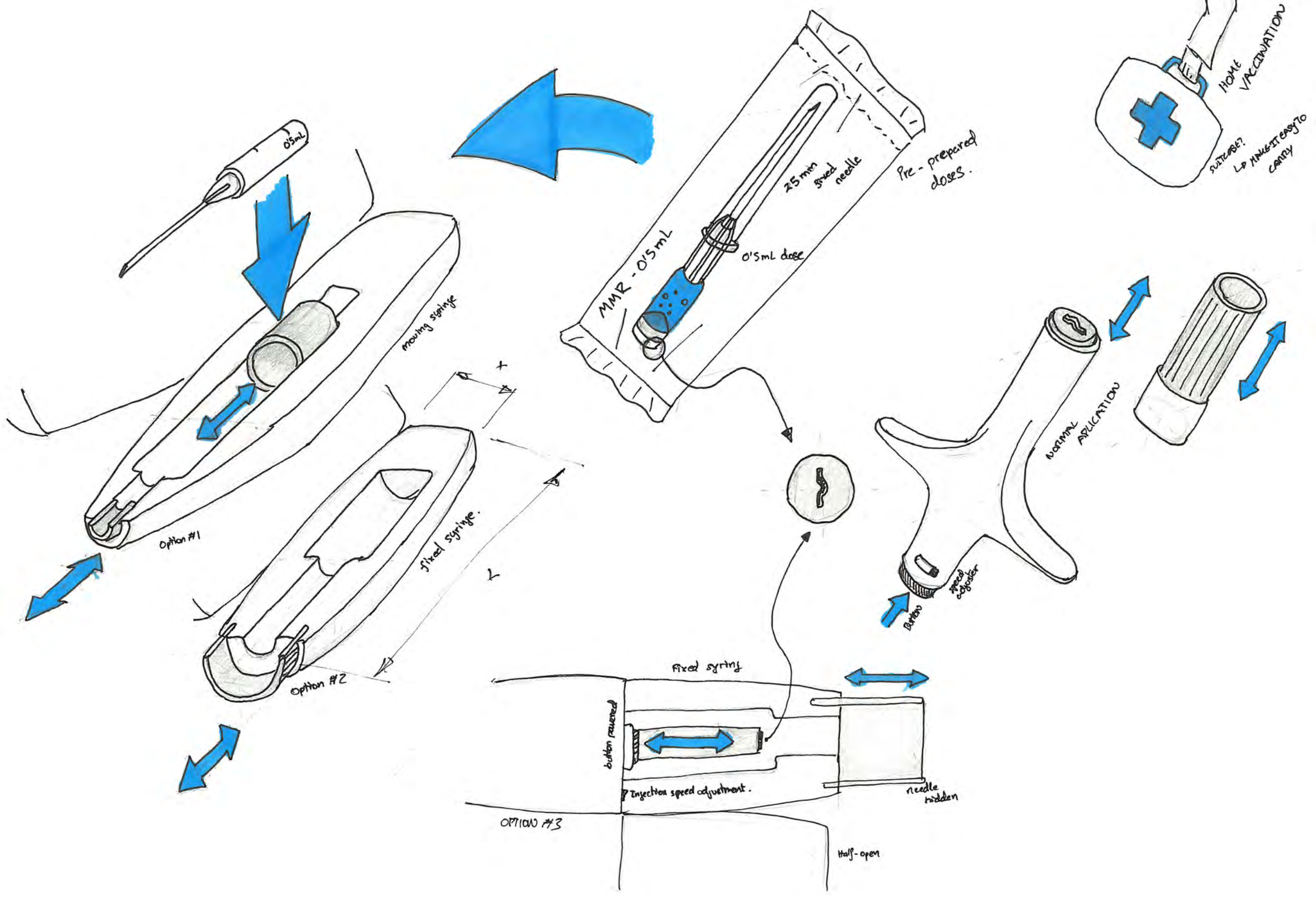

2/10
2/10

500 = n · 55? · A

100 / 114? = A · 1578



The Syrina™ range of self-injection devices from Becton Dickinson includes assisted syringes with needle safety features as well as three variations of autoinjector. All of these systems utilize the same VapourSoft™ powerpack system.

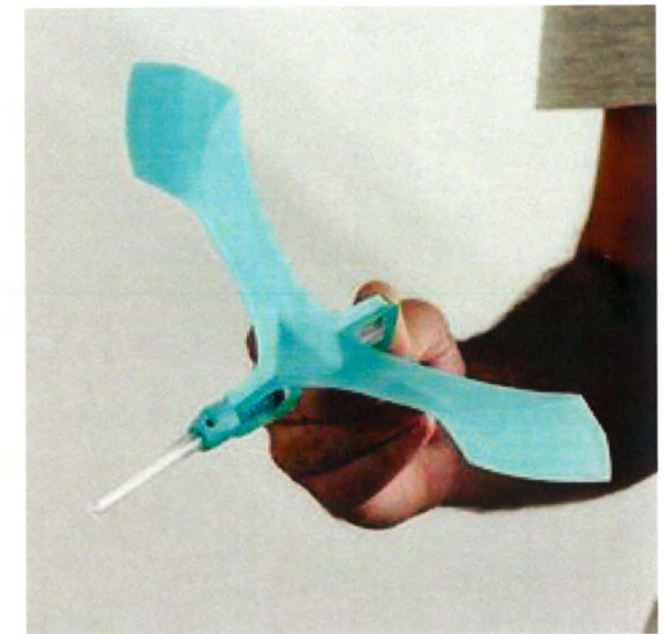

VACCJECT™
RETRACTION FOR USE



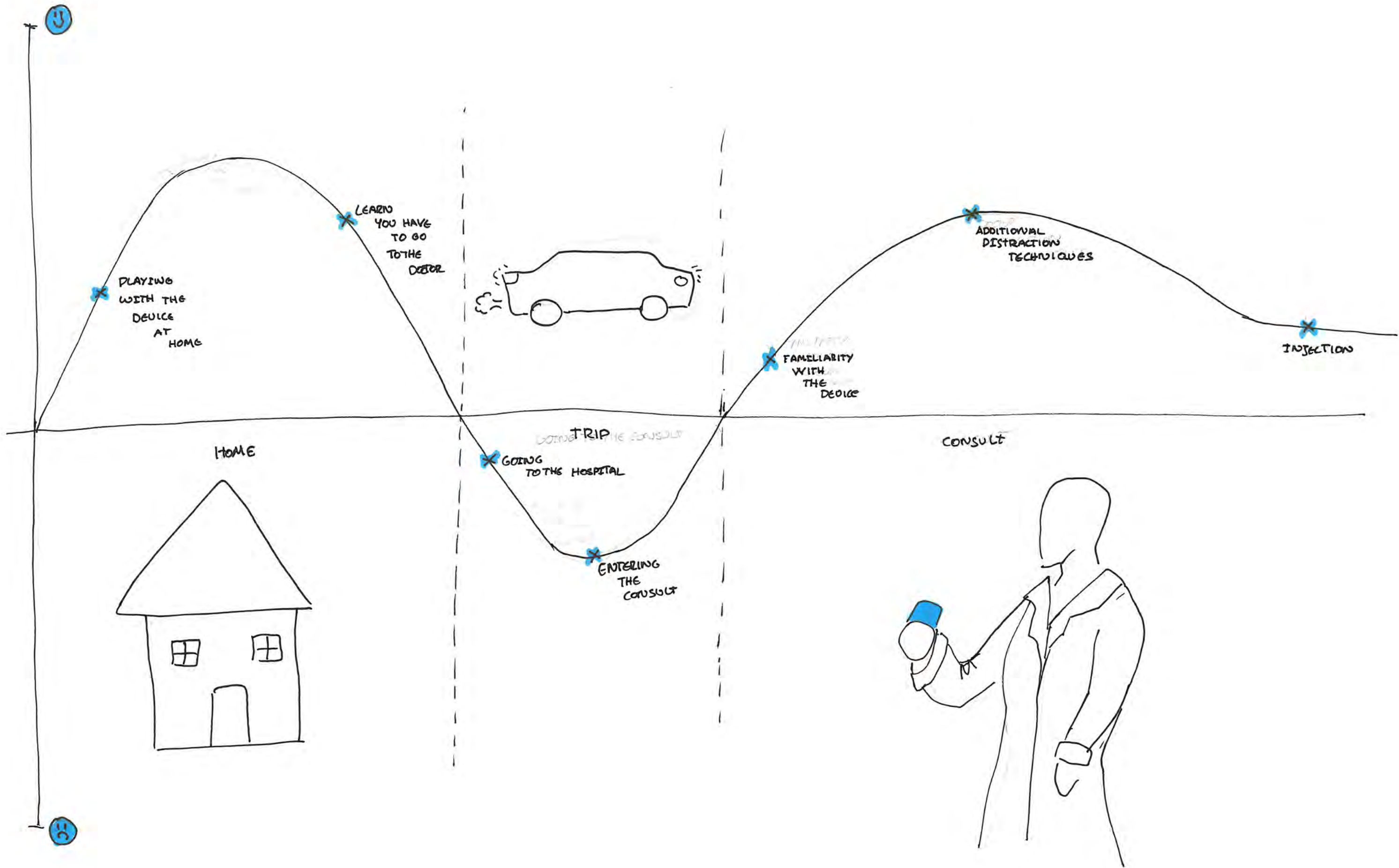

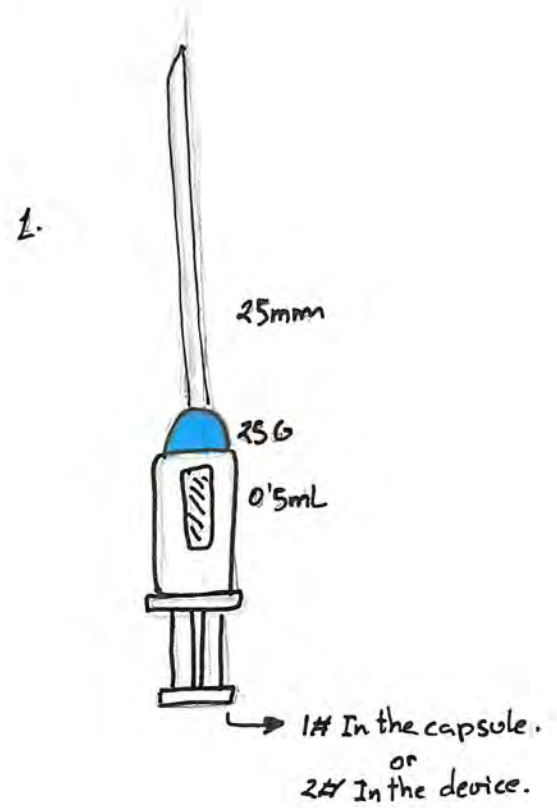
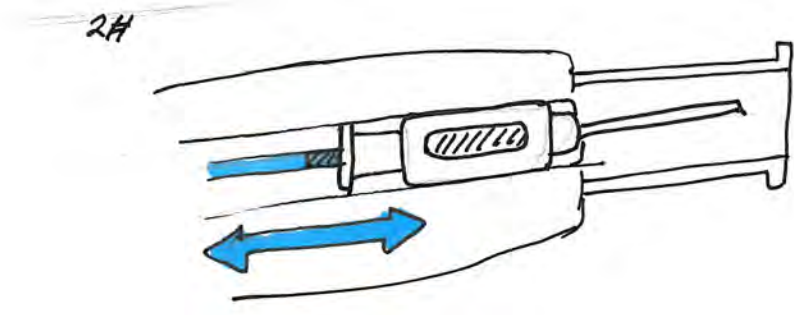
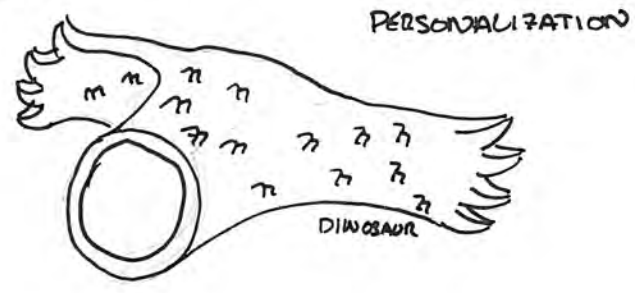
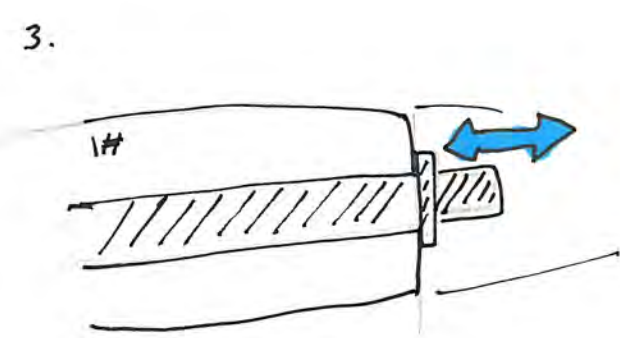
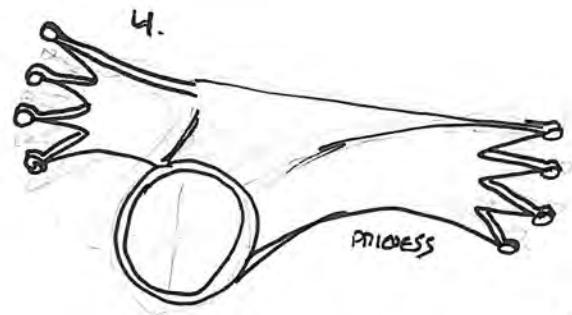
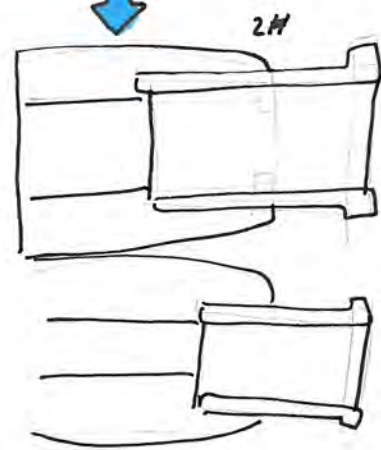
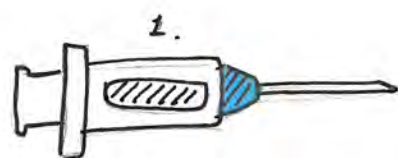
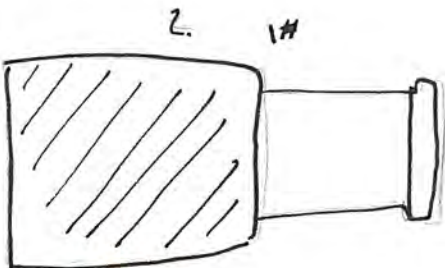
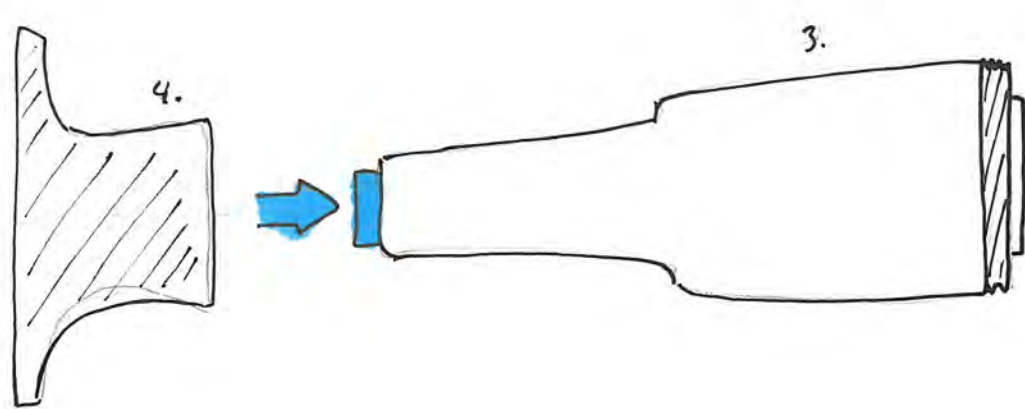

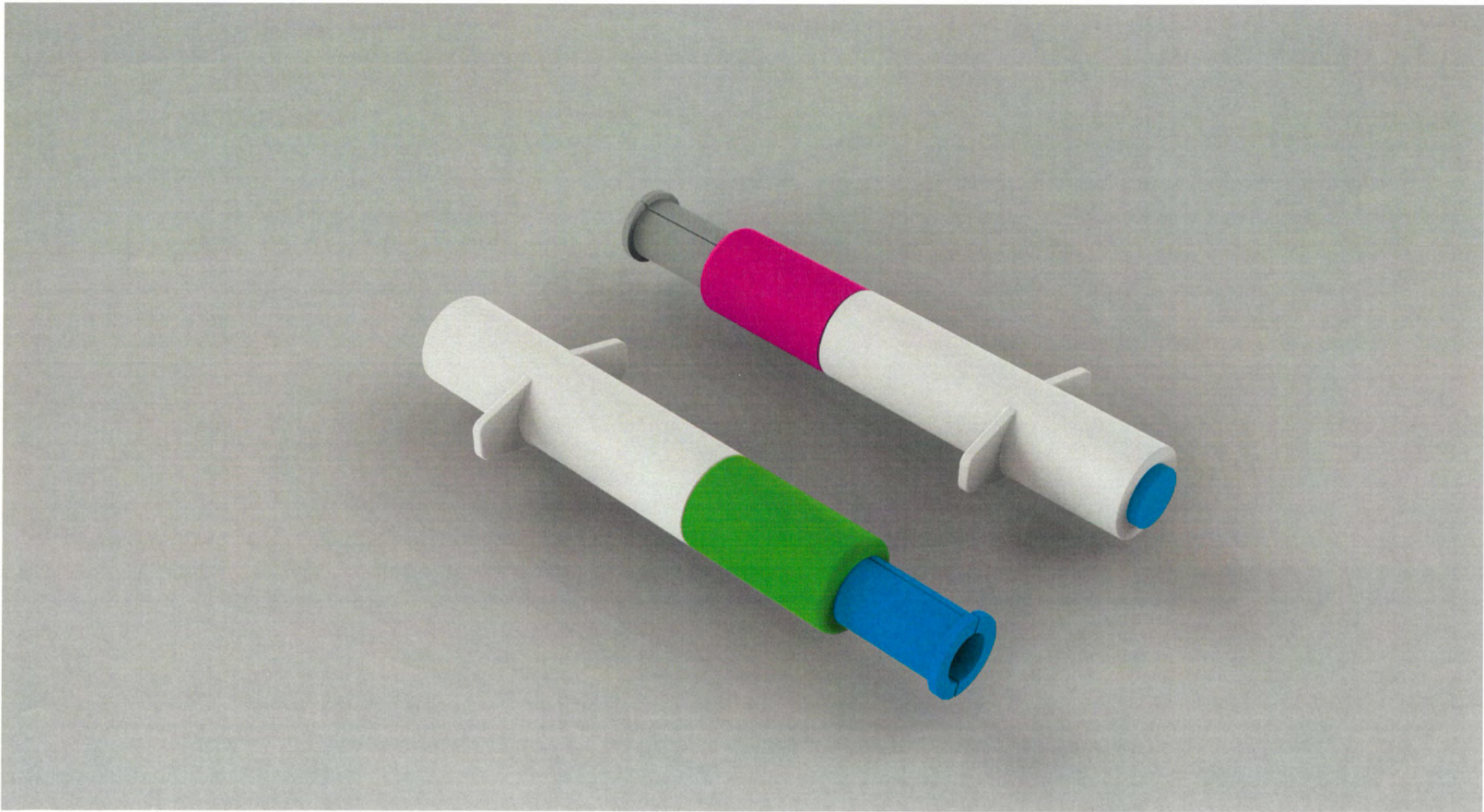
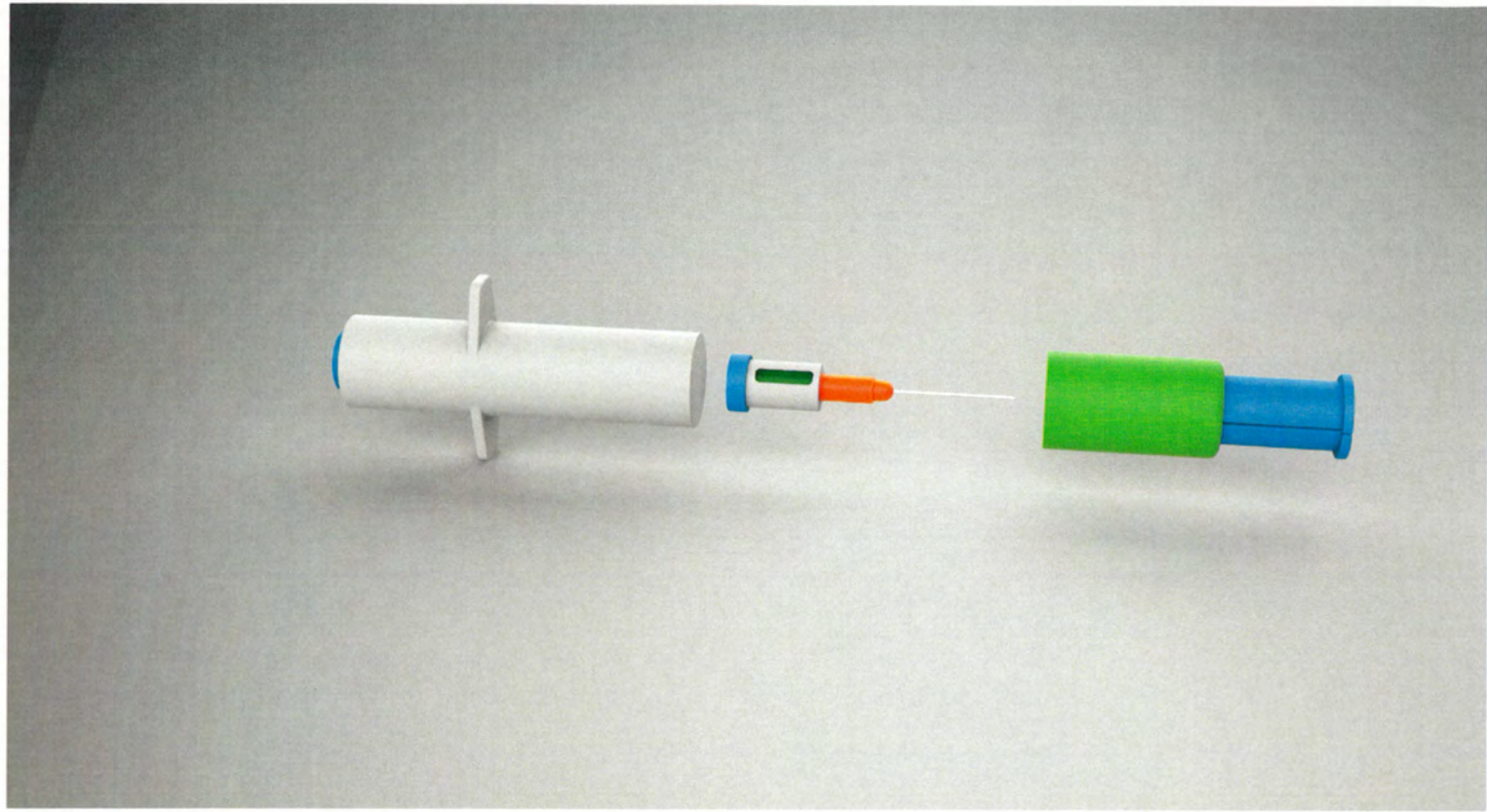

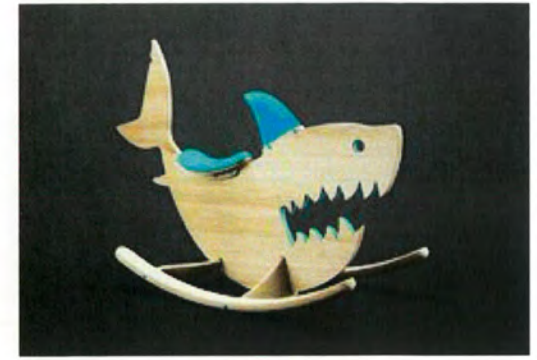

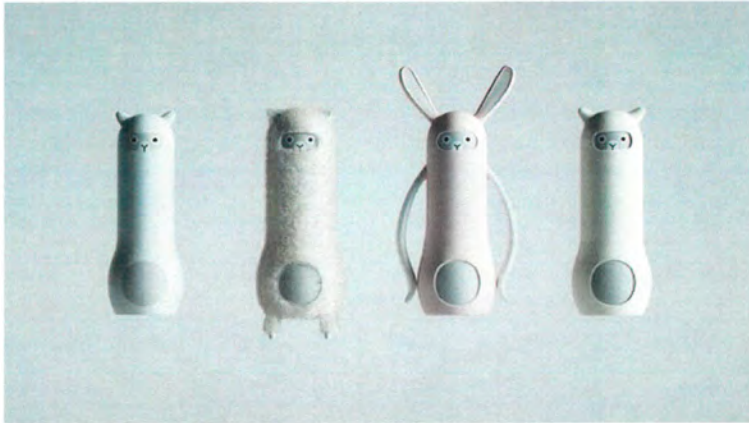
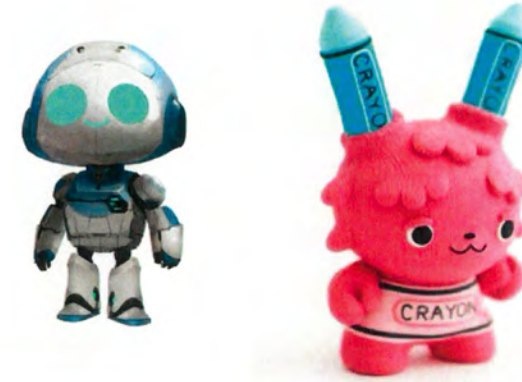

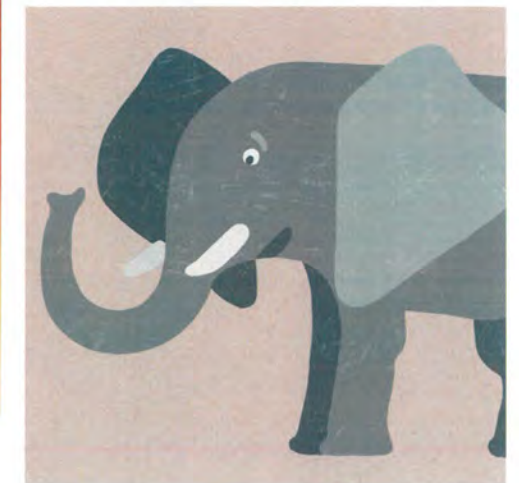
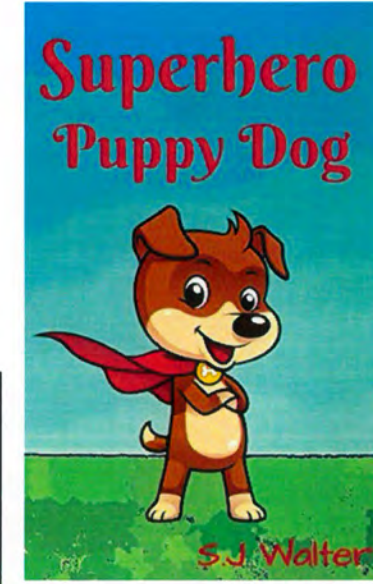
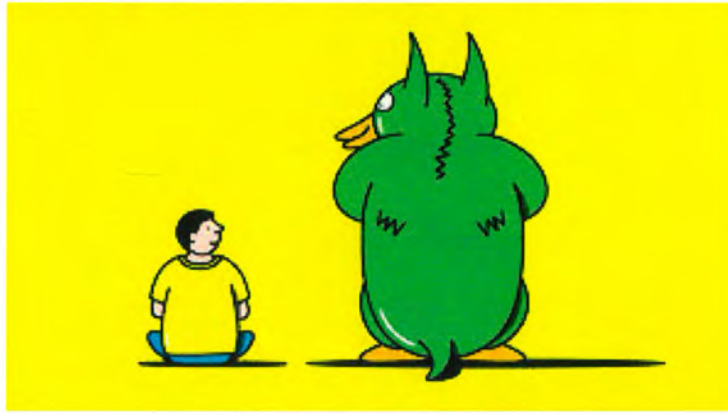
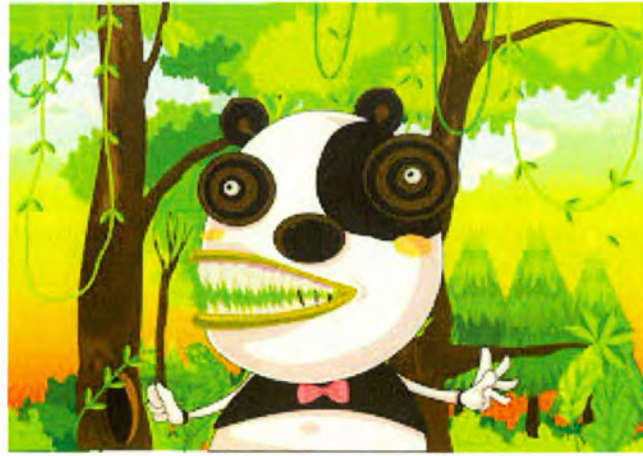

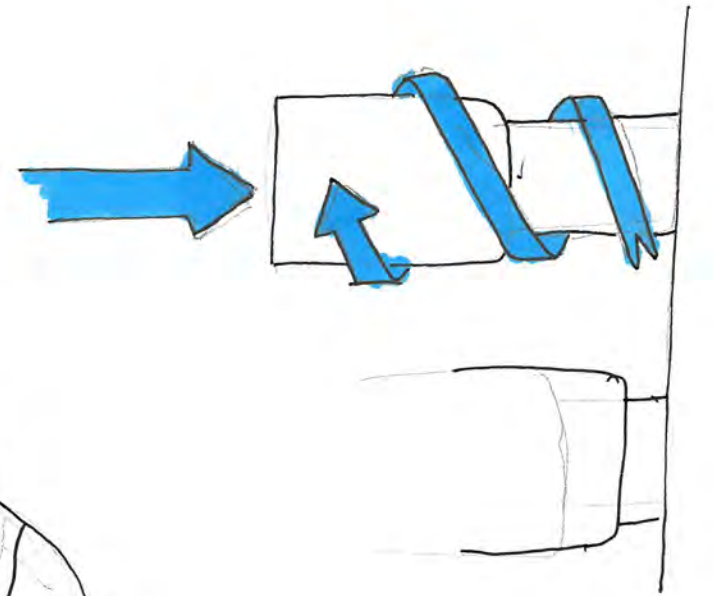
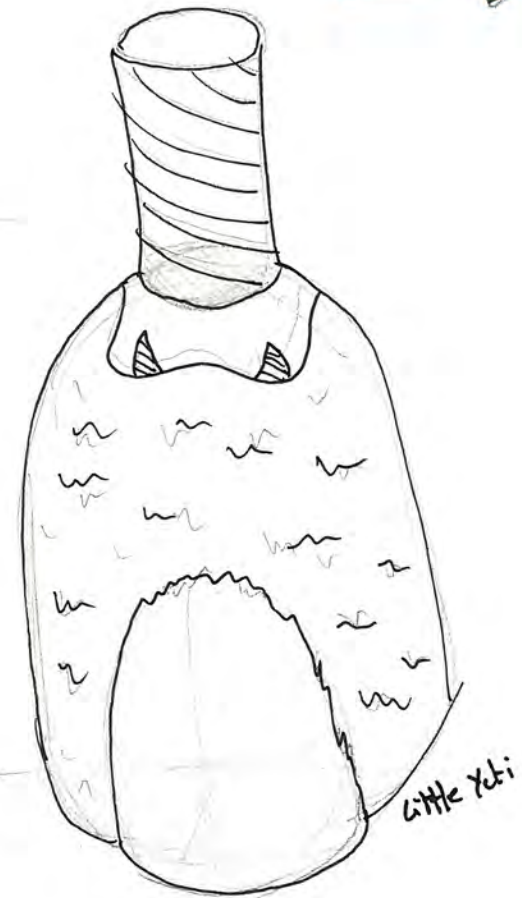
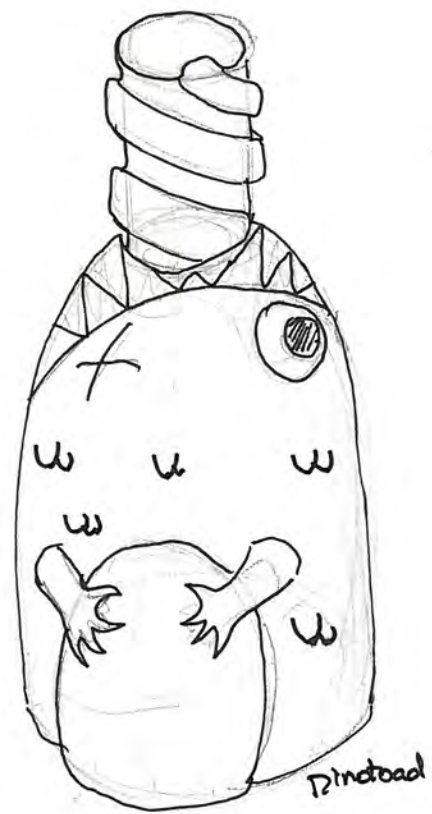
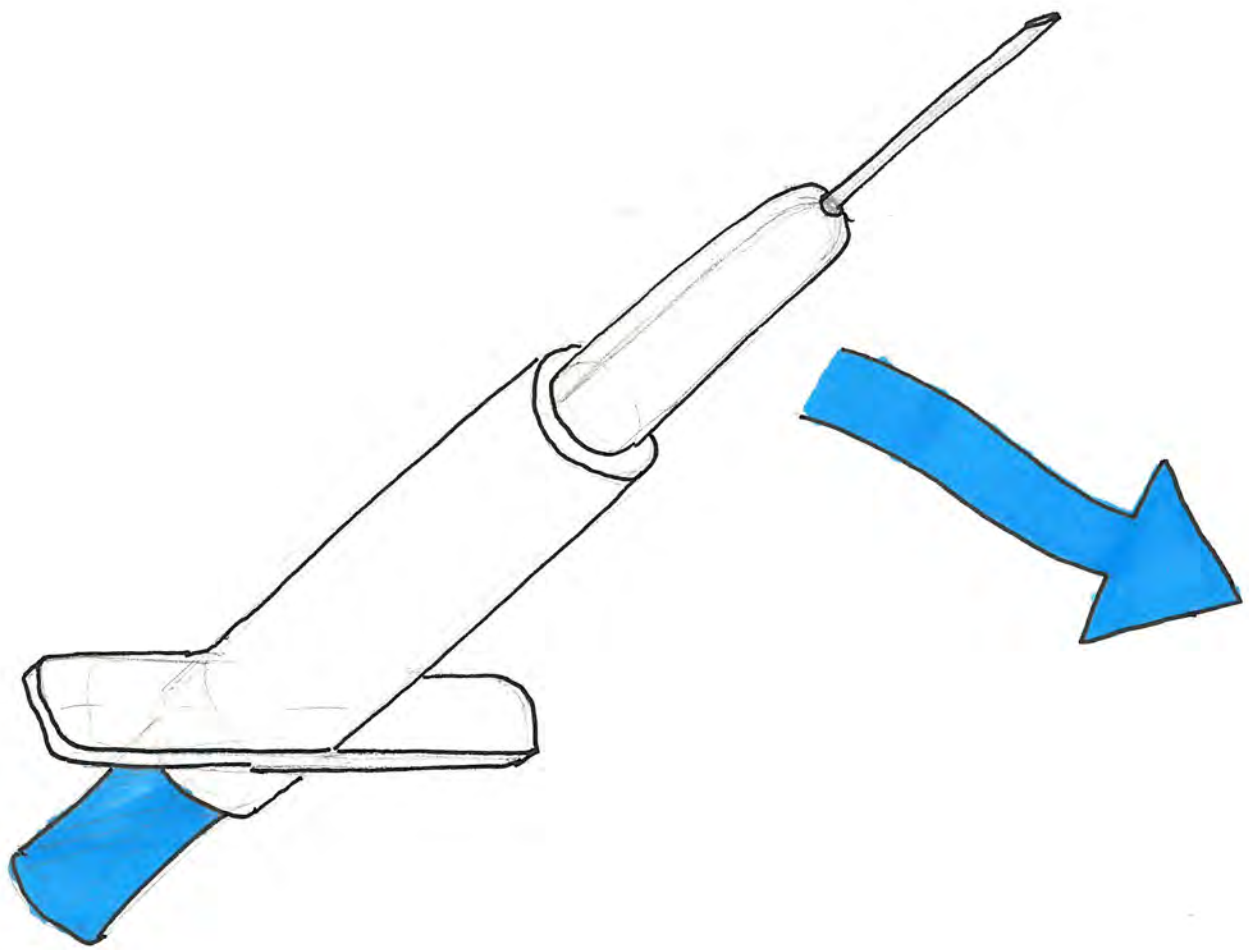

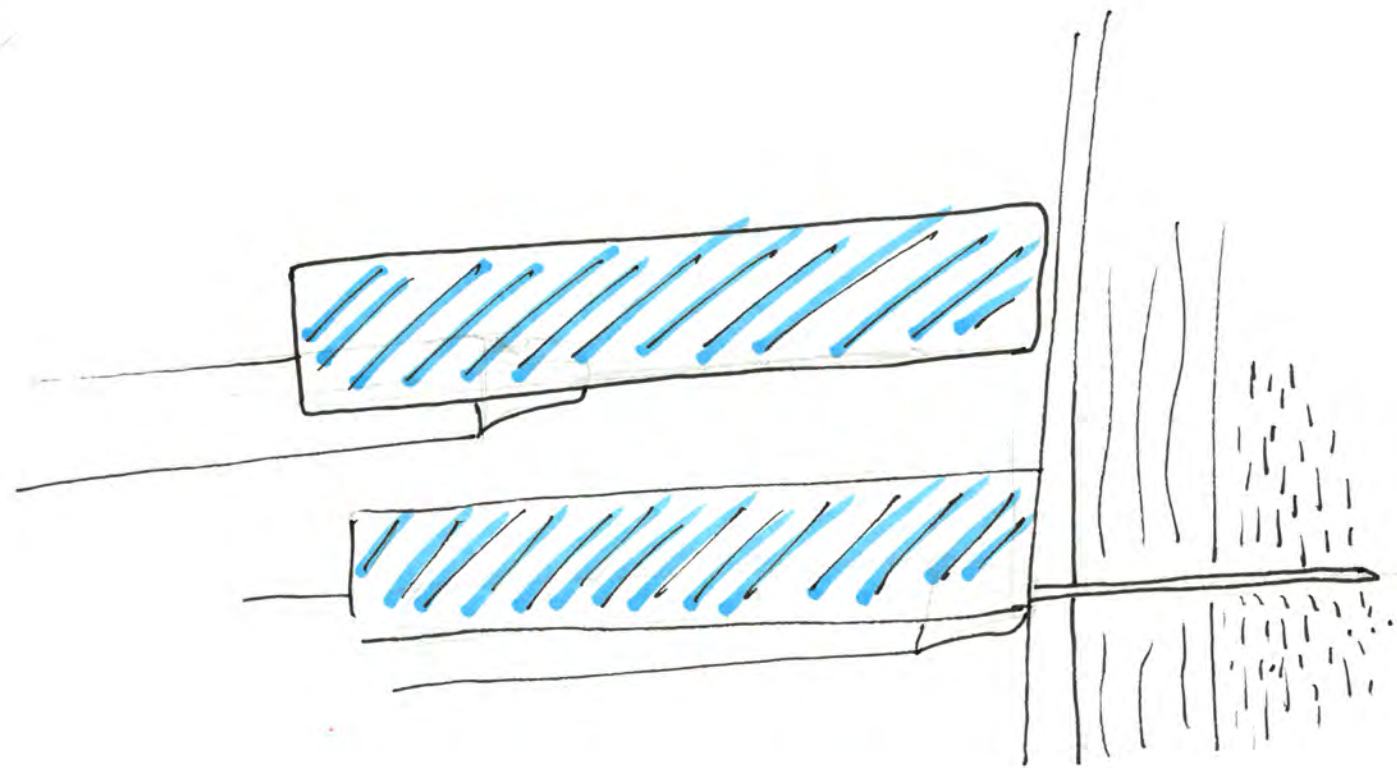
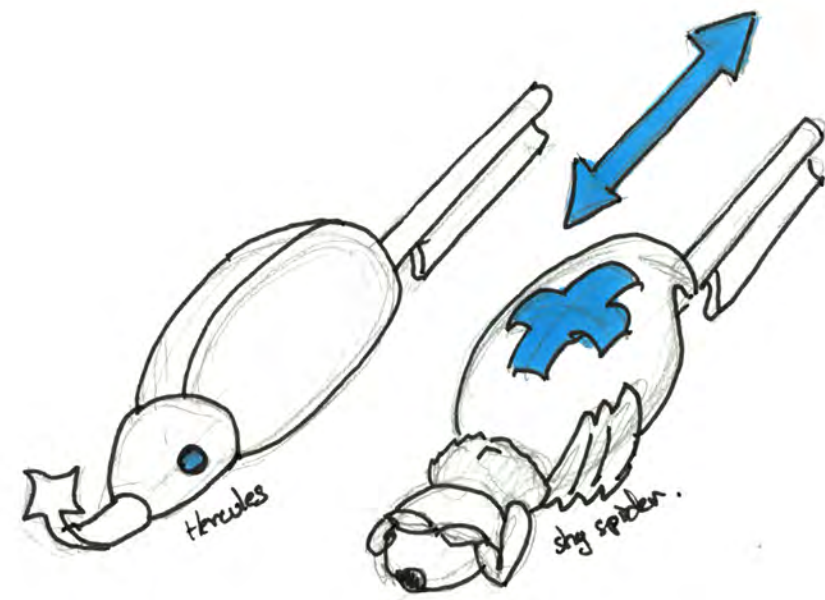
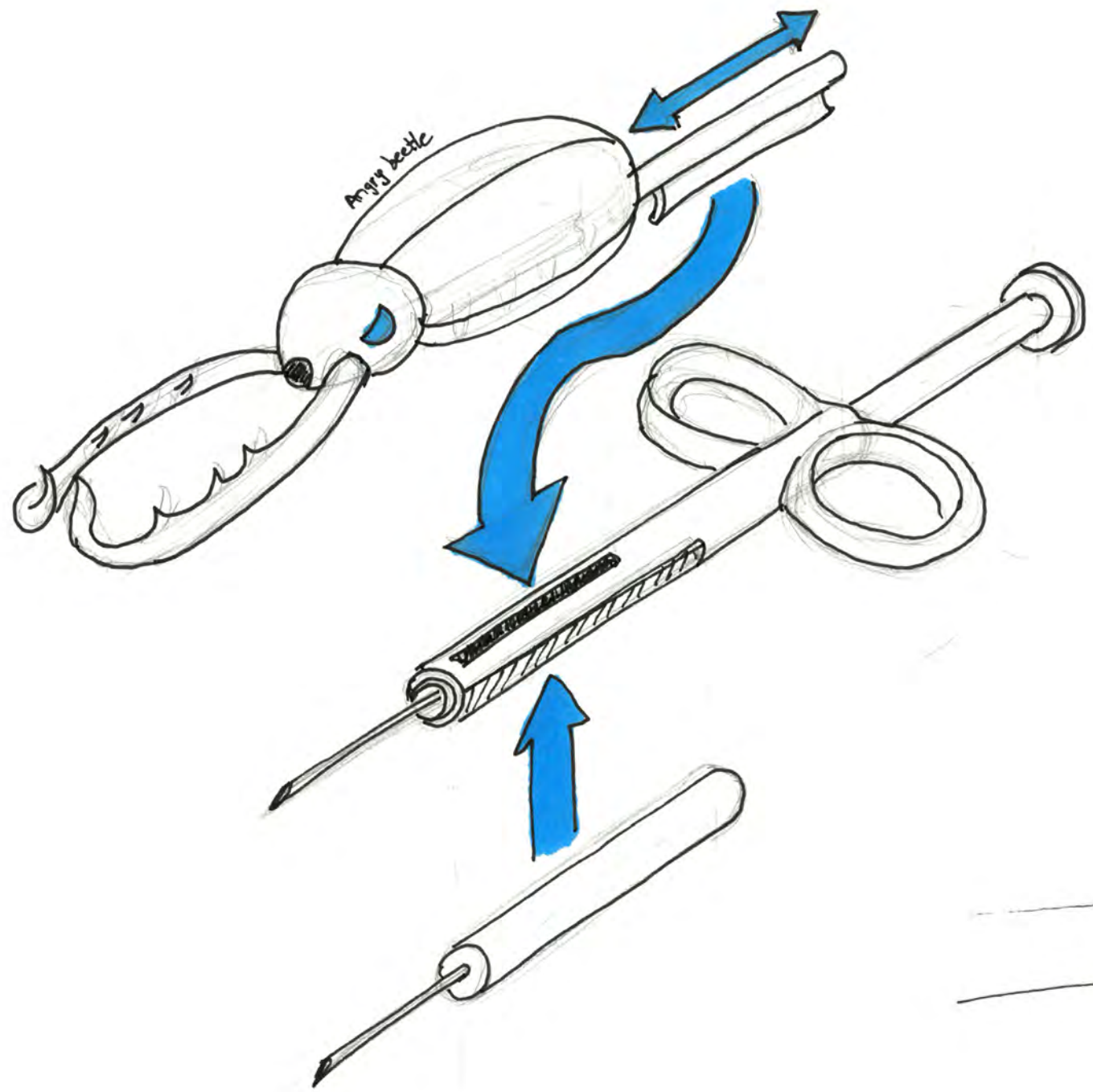

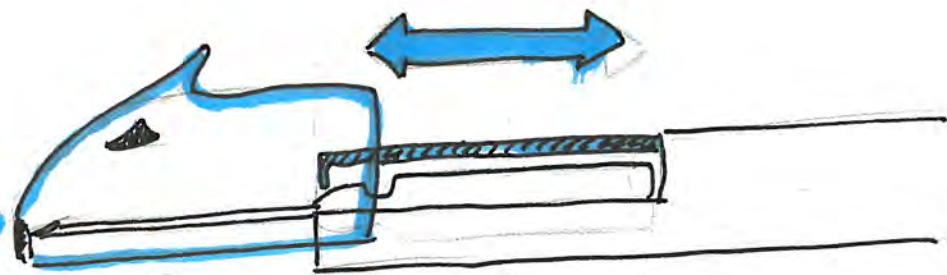
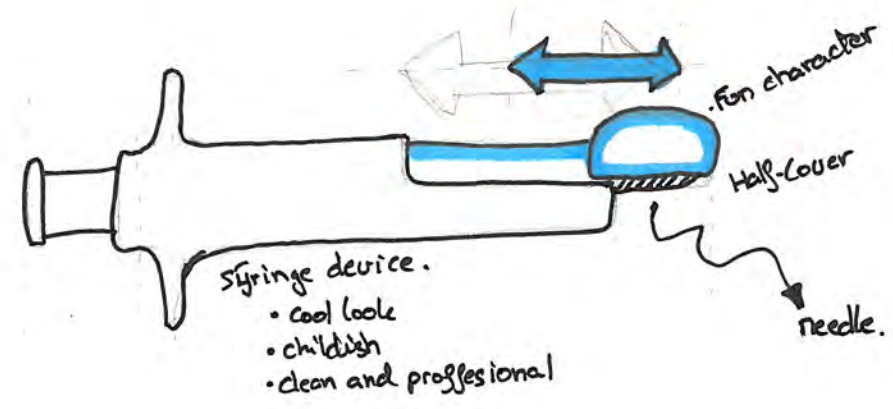
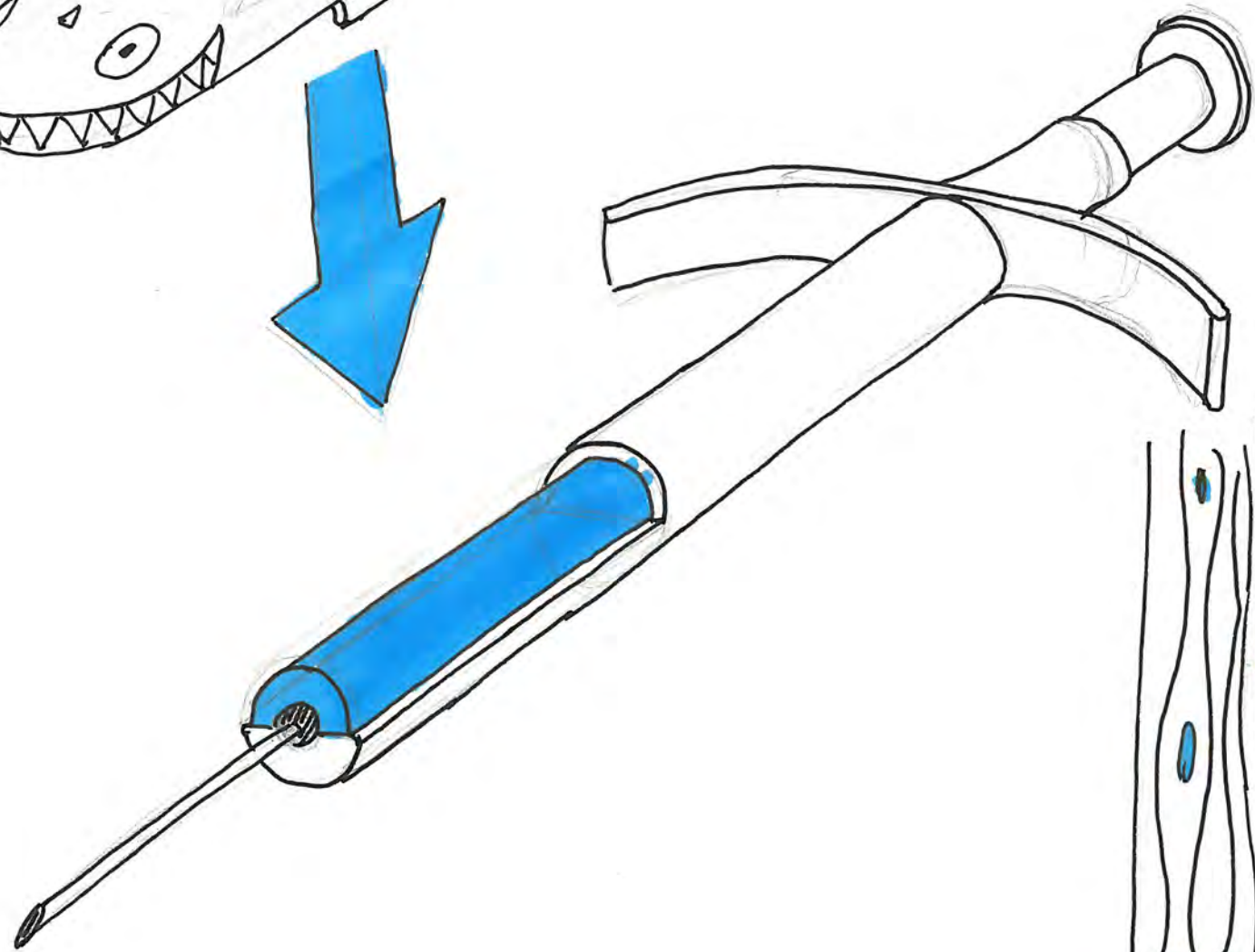
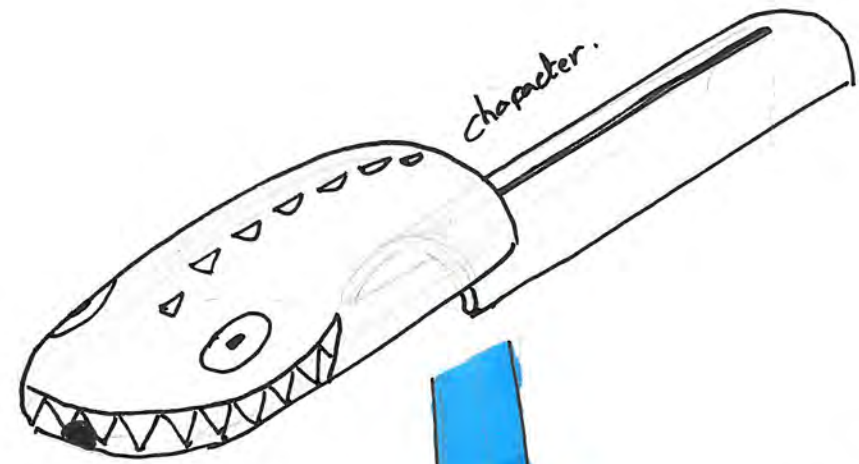

History
Poster
Collectible.
App?



Model

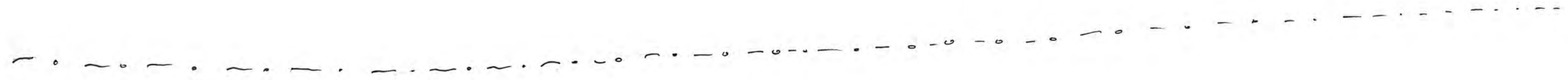
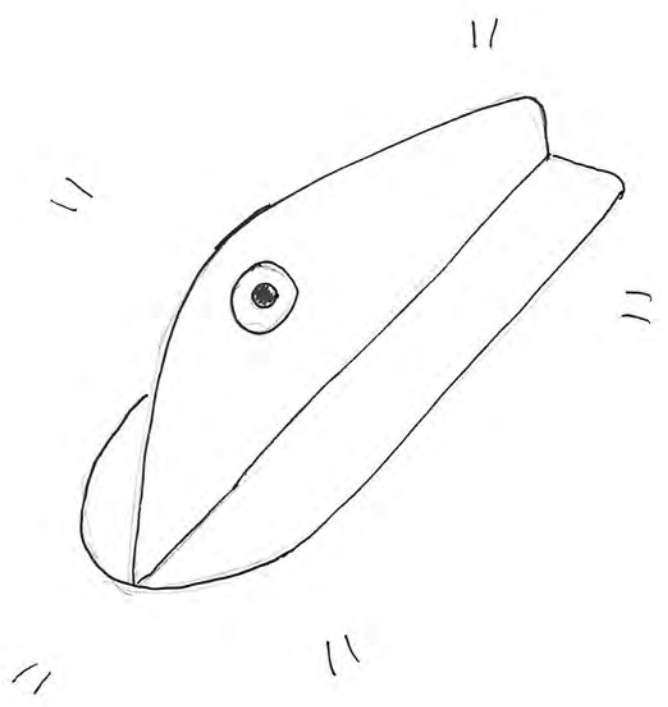
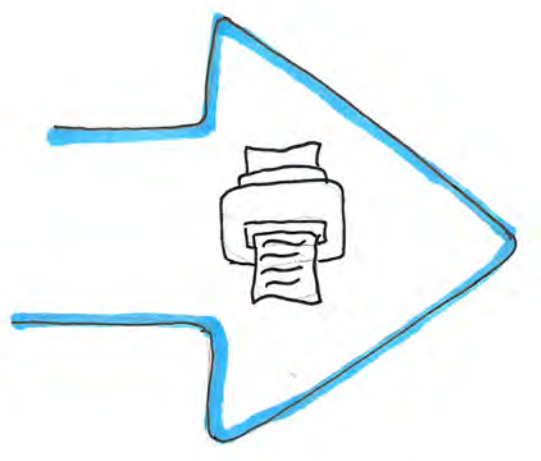
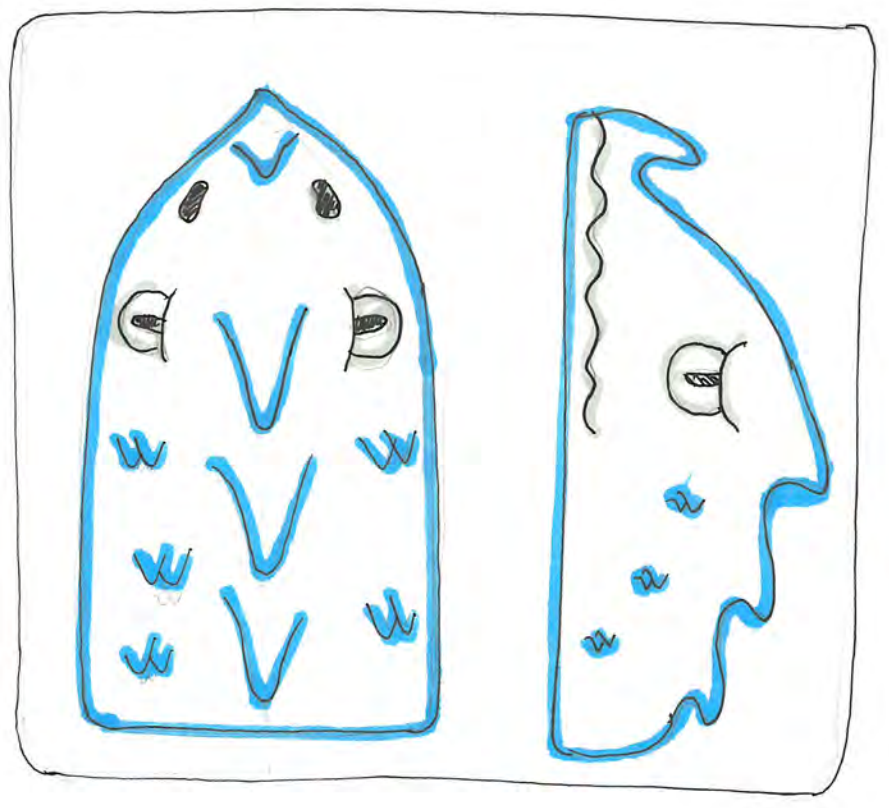

1°

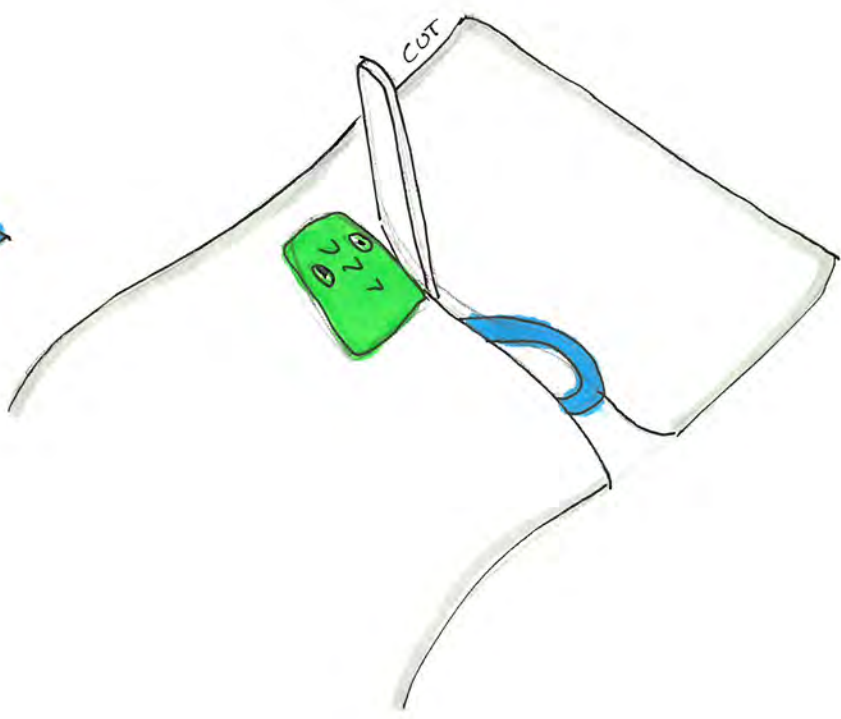
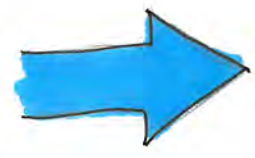

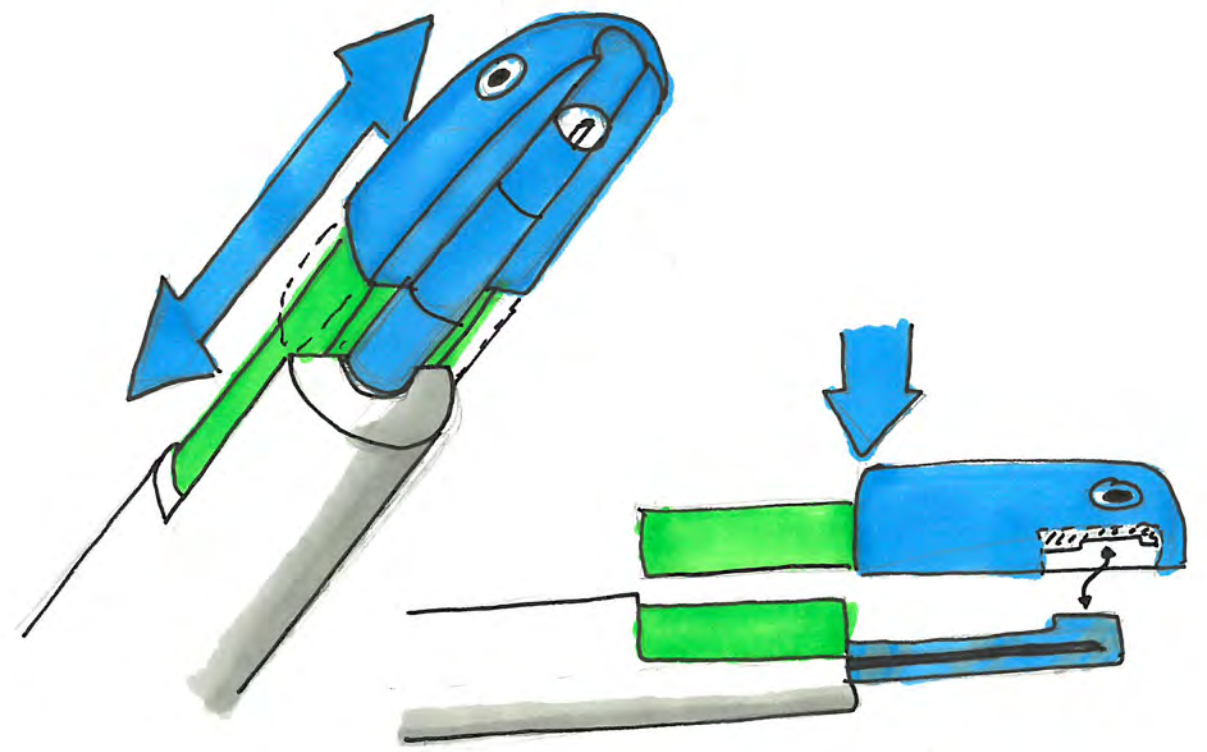
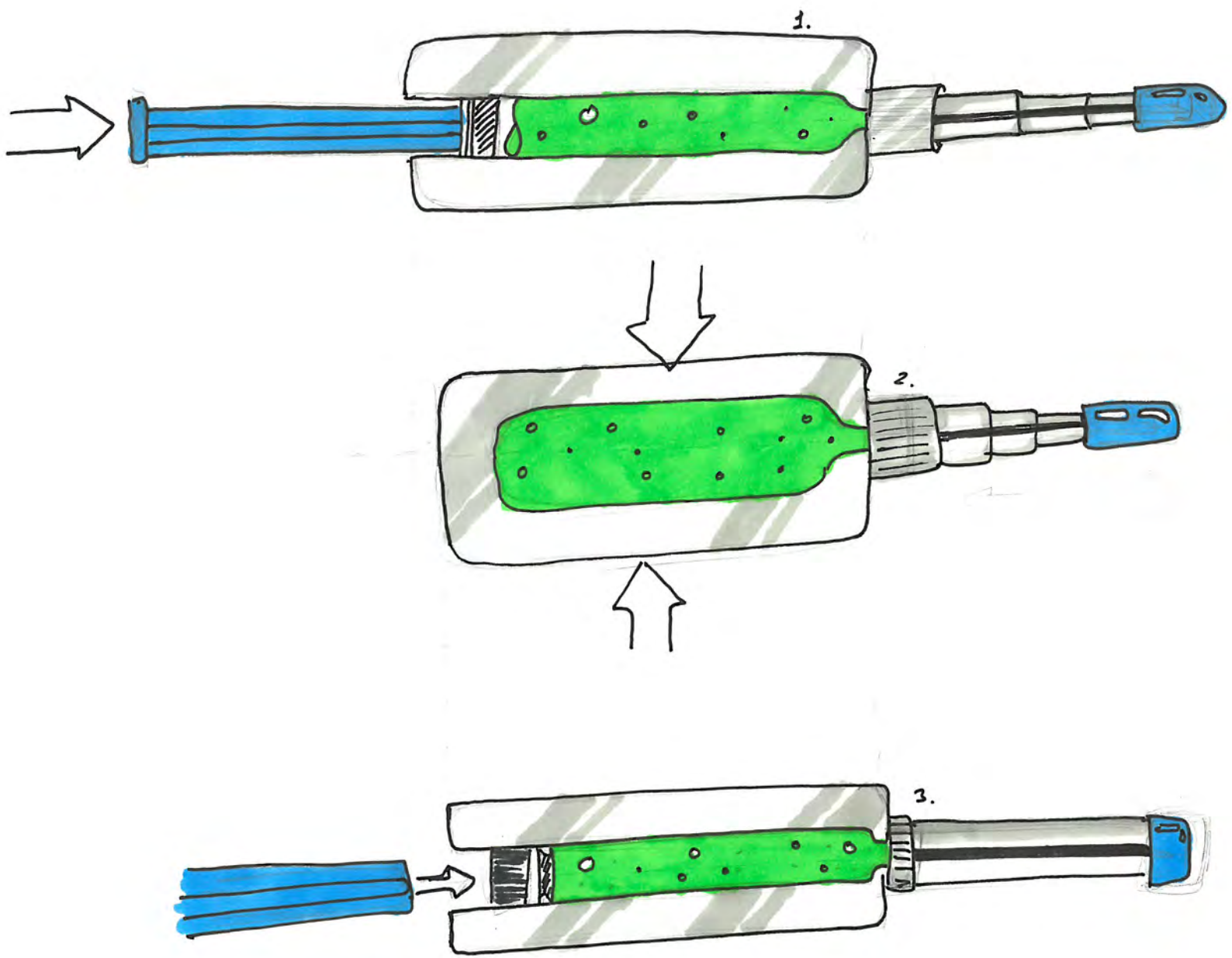

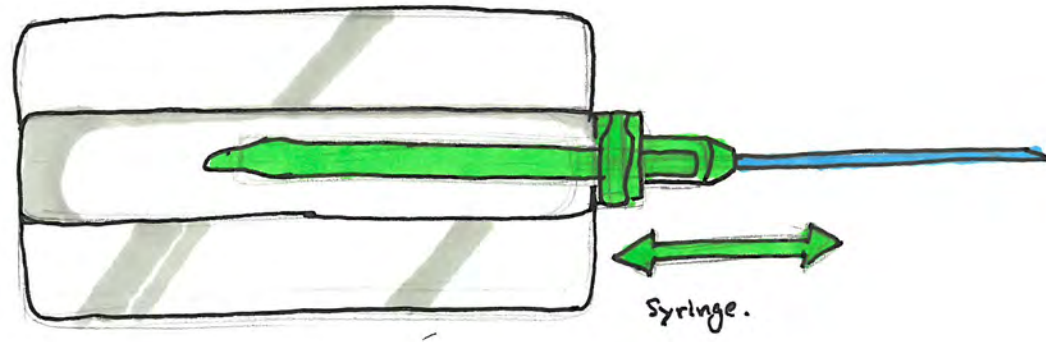
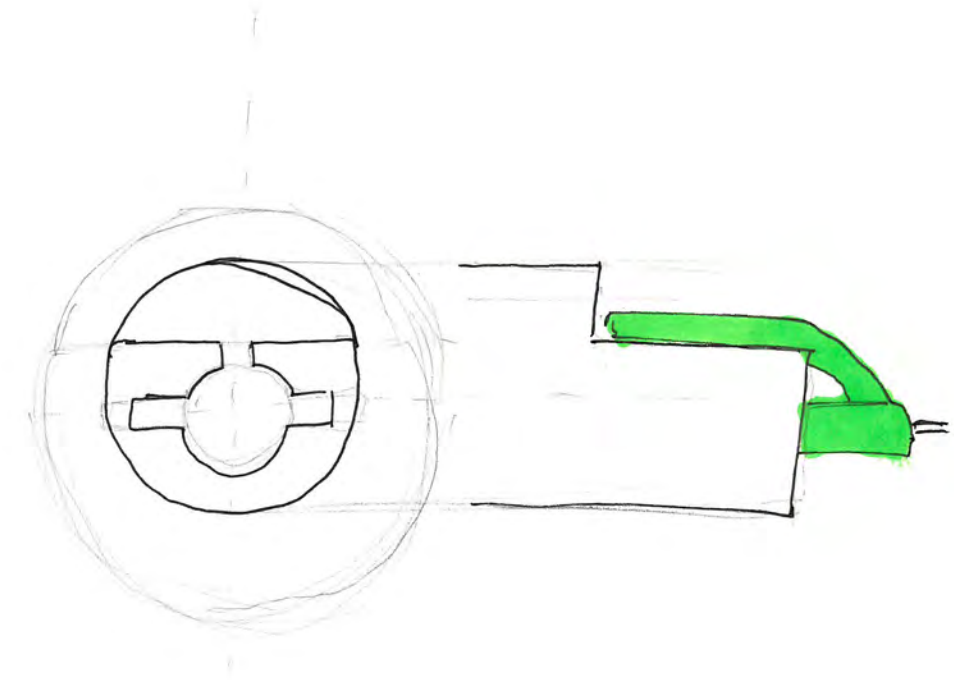
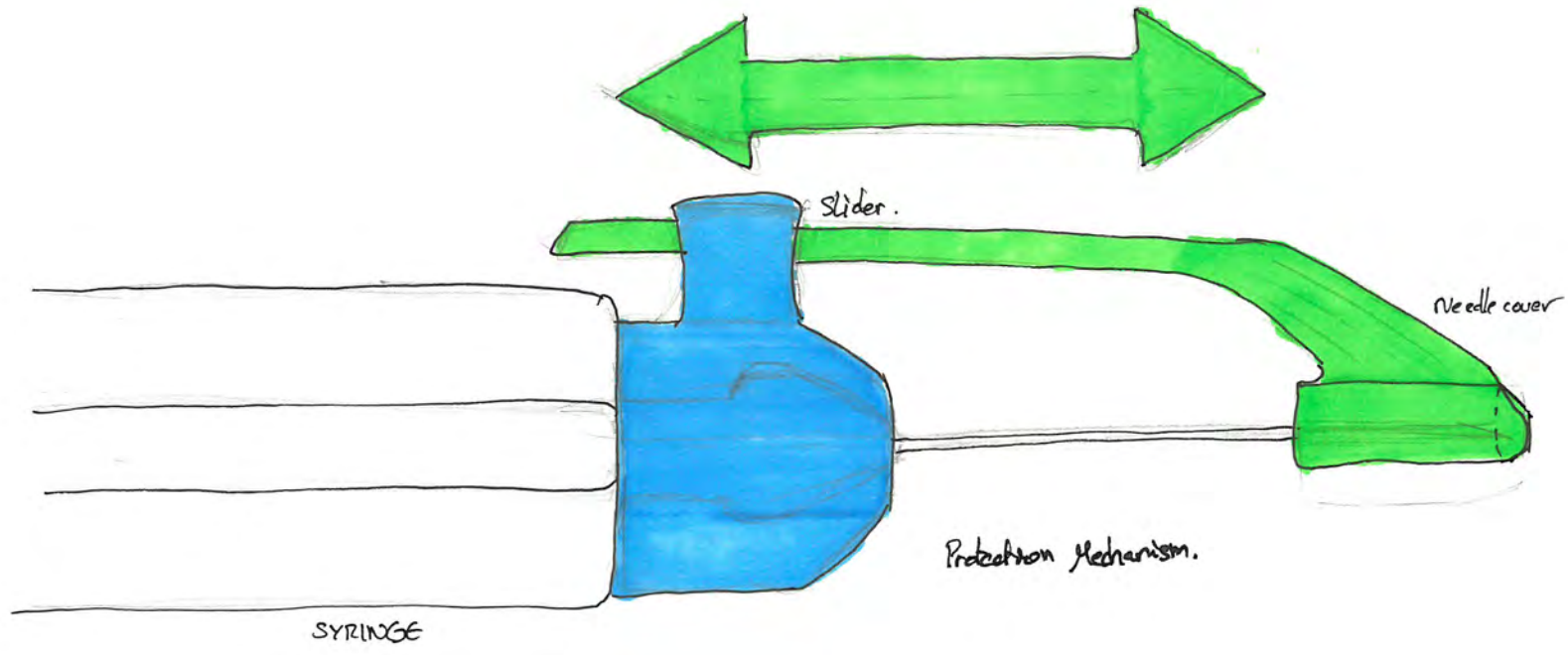

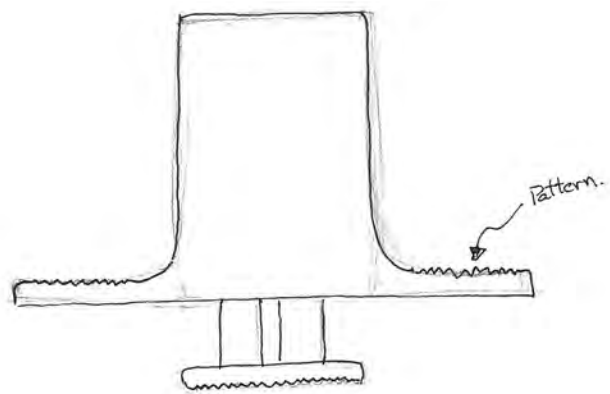

Patterns.

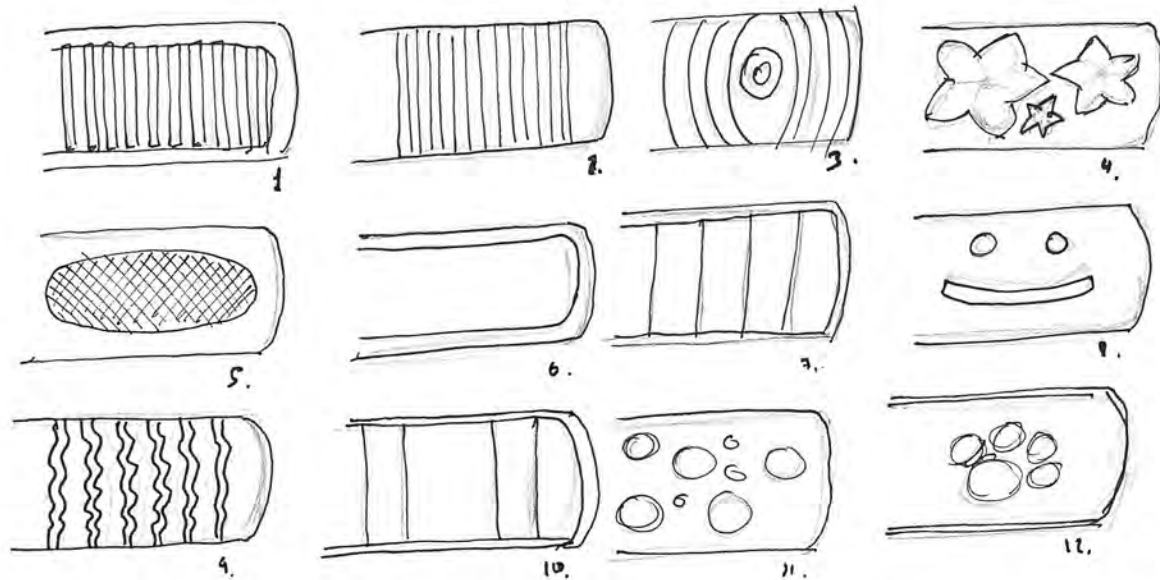

Shapes.

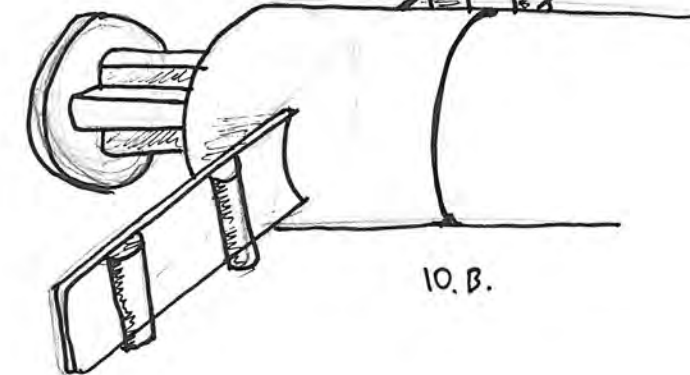
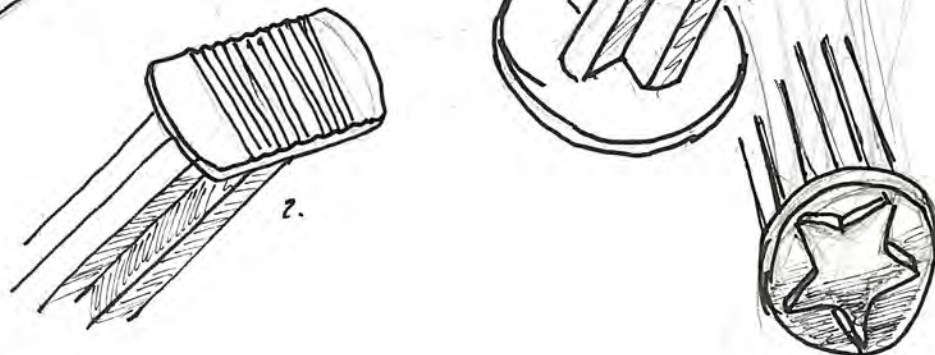
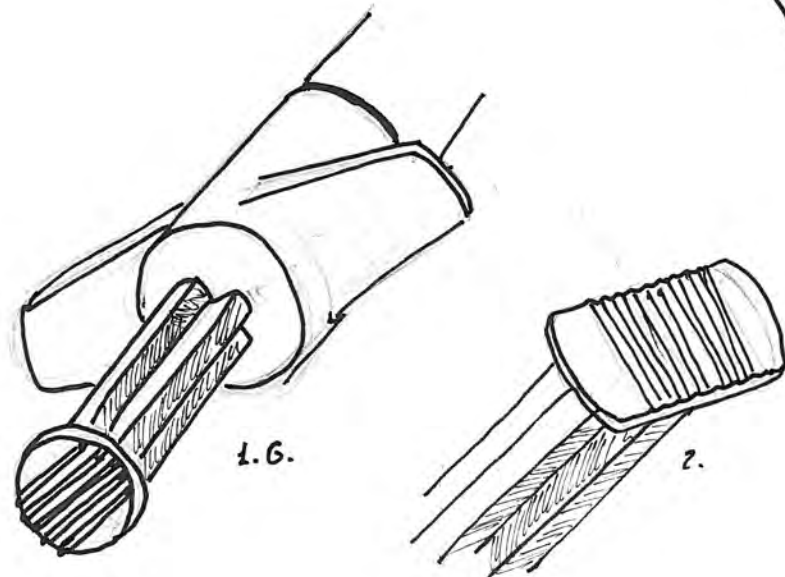
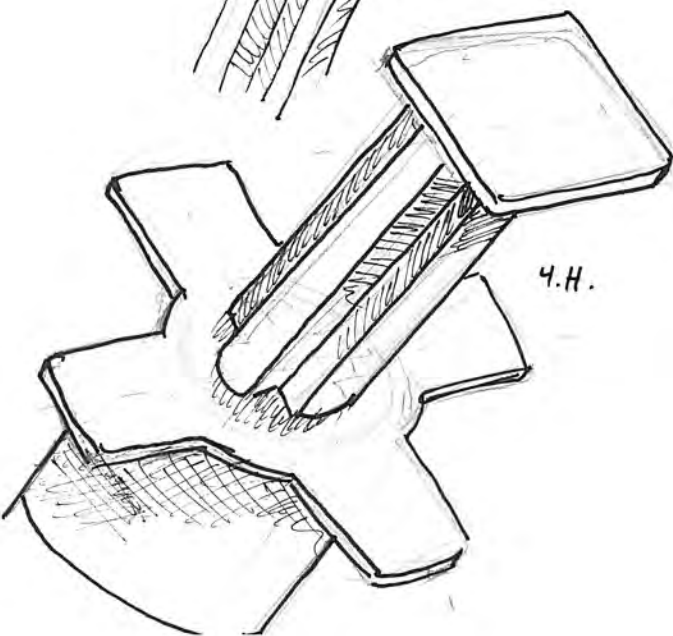
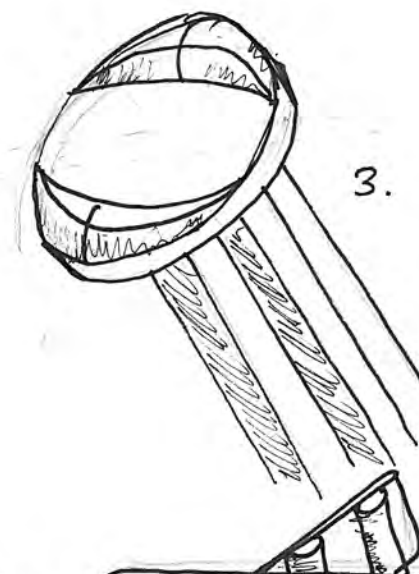
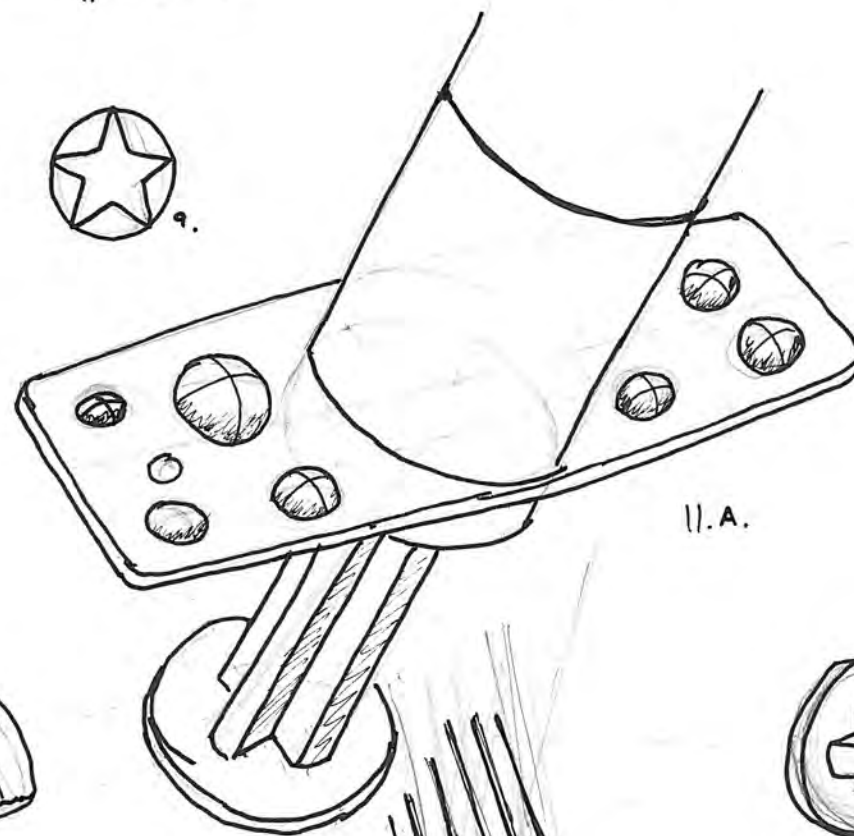
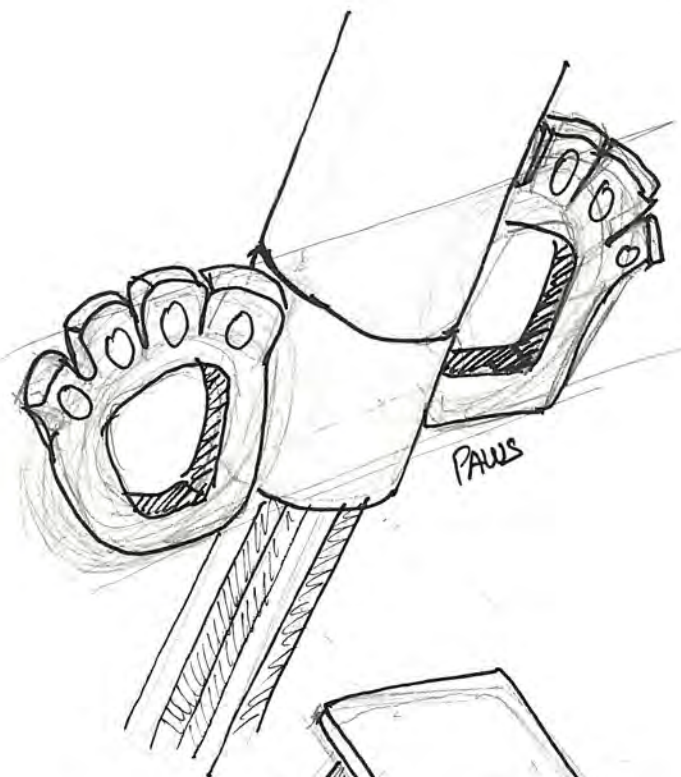
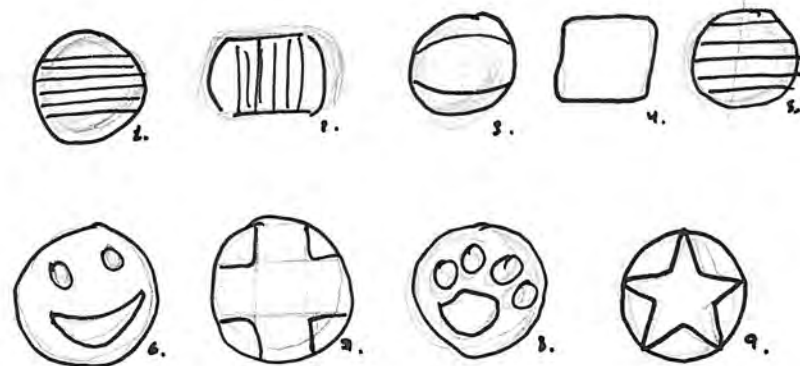
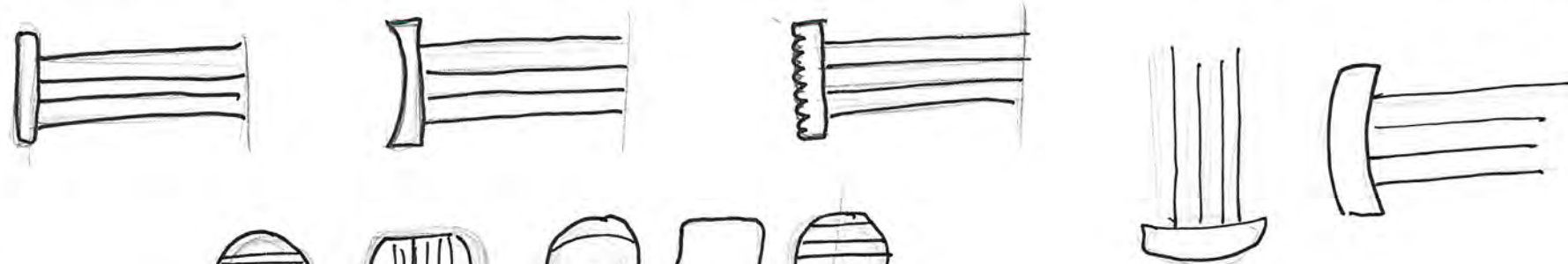
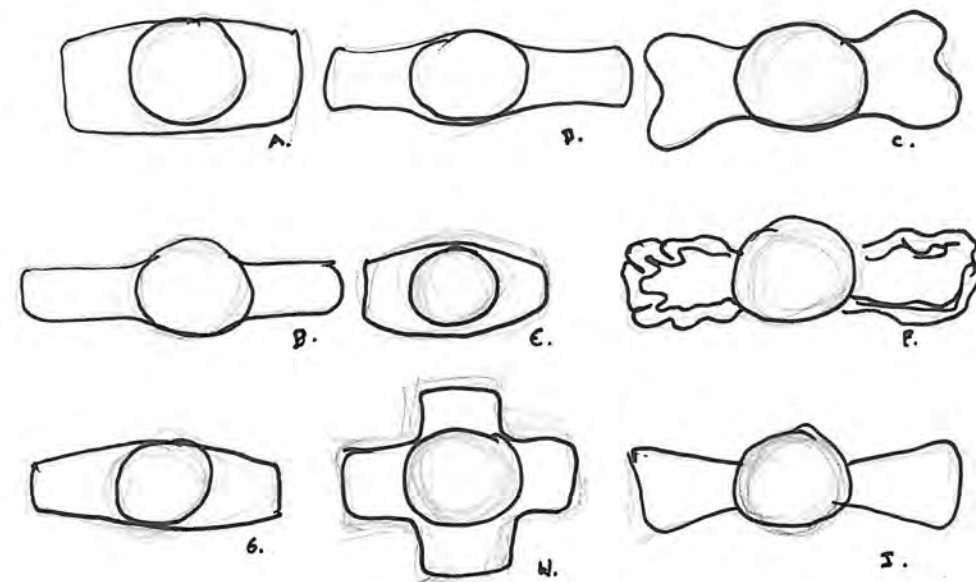

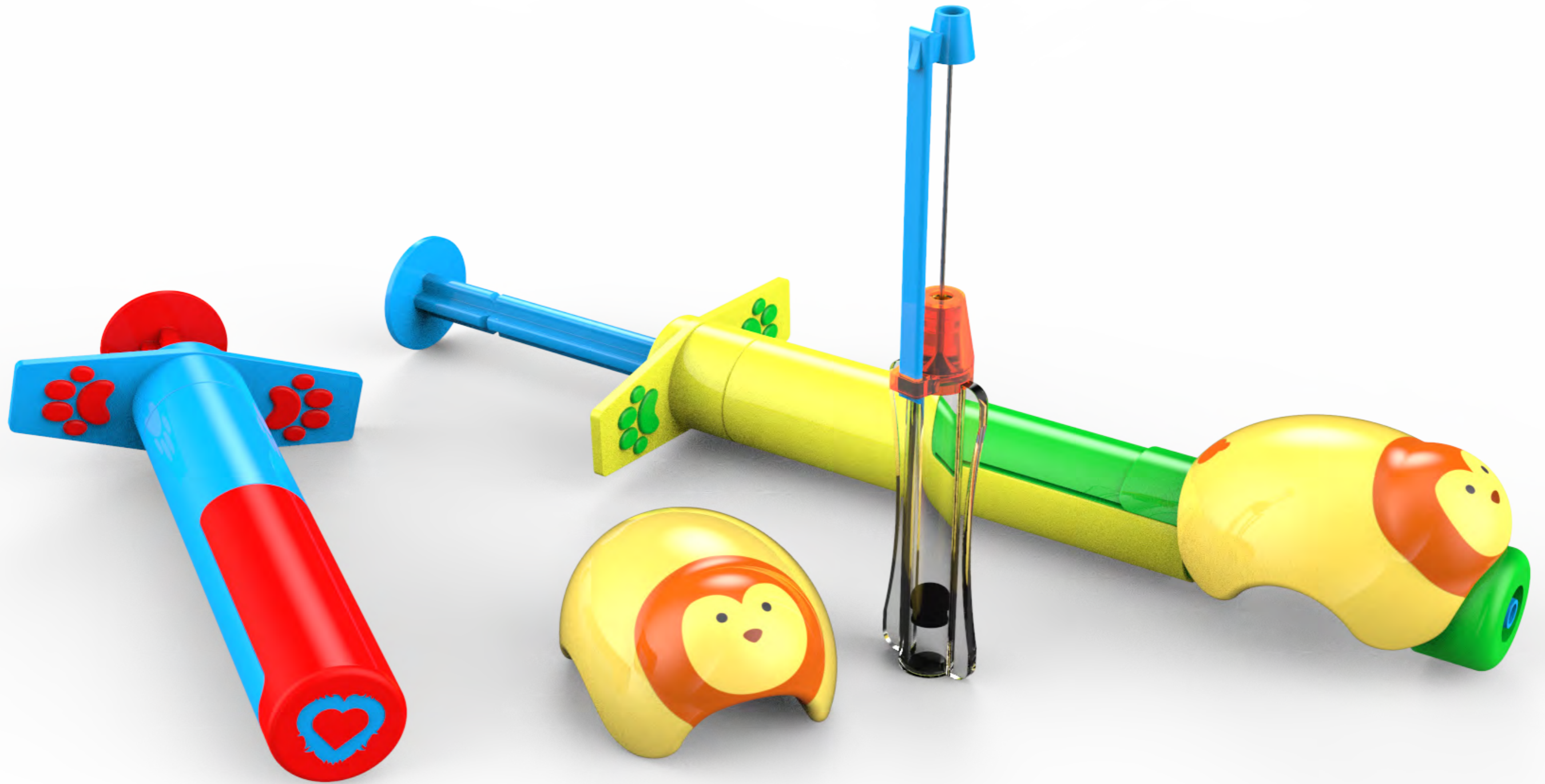

ANNEX 5

Detail and Specification

8	7	6	5	4	3	2	1
Rev	Change Doc.	Date	Change Detail				

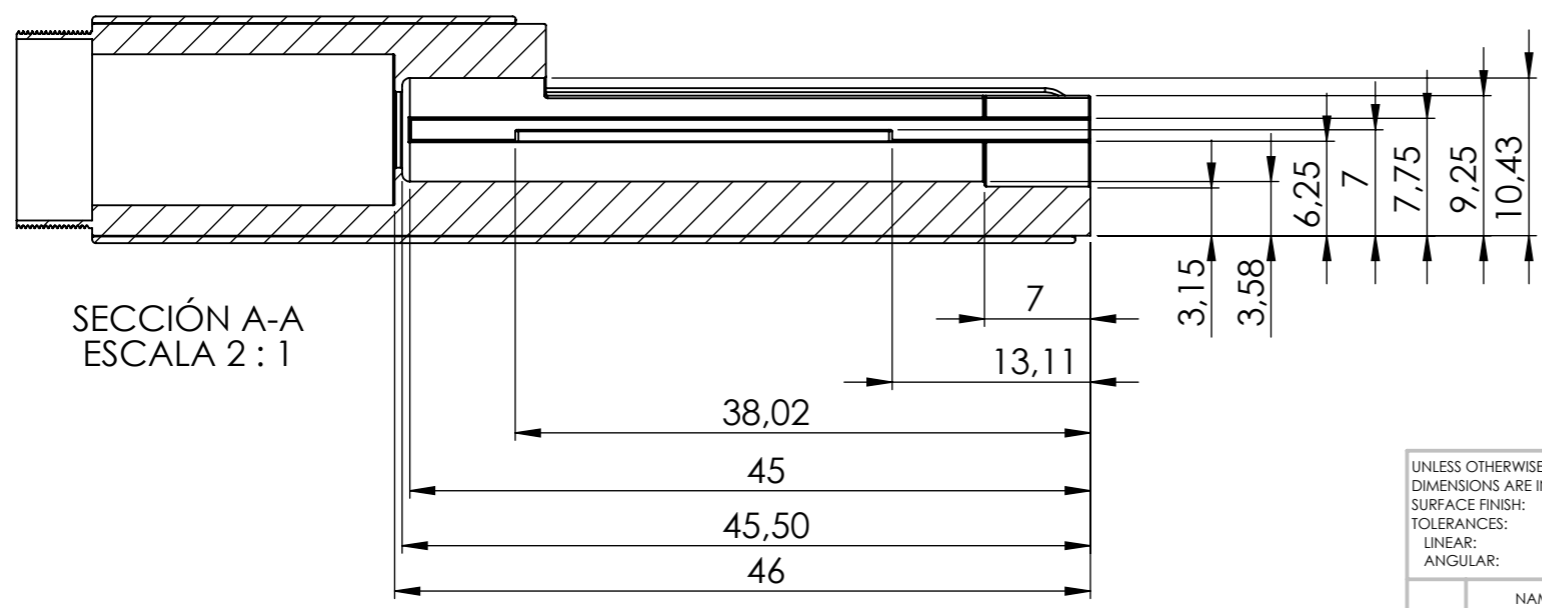
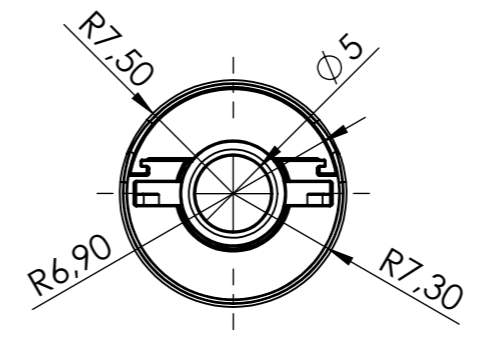
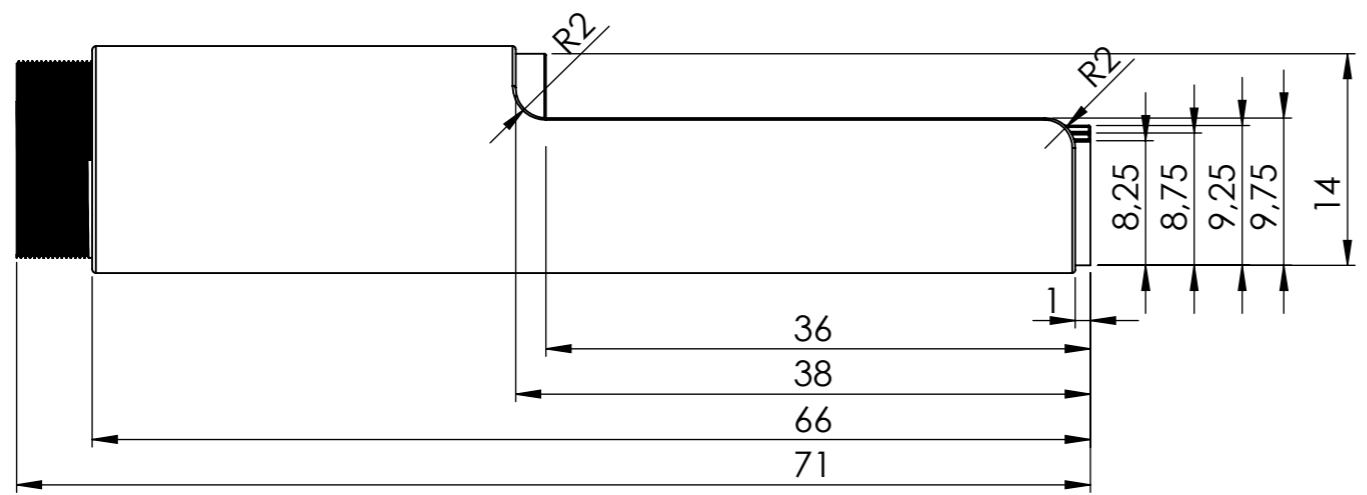
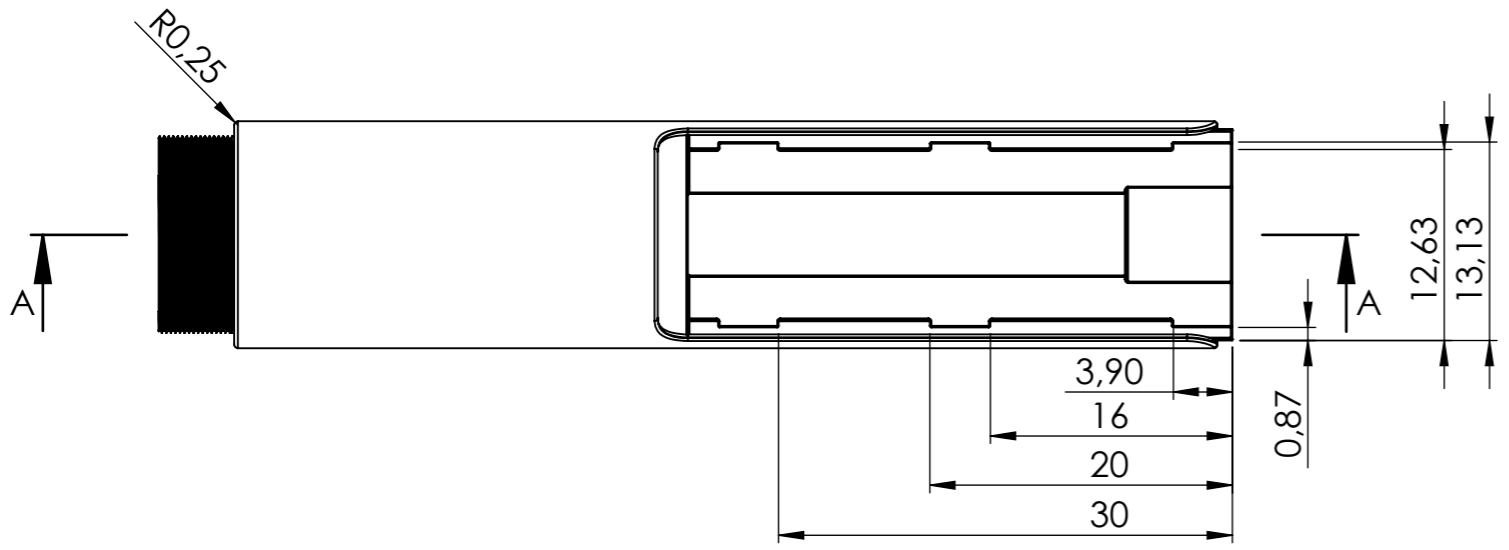

SECCIÓN A-A
ESCALA 2 : 1

UNLESS OTHERWISE SPECIFIED: DIMENSIONS ARE IN MILLIMETERS SURFACE FINISH: TOLERANCES: LINEAR: ANGULAR:			MATERIAL: Plastic FINISH: Shiny	DEBURR AND BREAK SHARP EDGES	DO NOT SCALE DRAWING	REVISION
DRAWN Sergio Suanzes				PROJECT: Anivac		TITLE: Syringe Exterior Body
CHK'D				PART NO. 1		A3
APPV'D				SCALE: 2:1		SHEET 1 OF 11

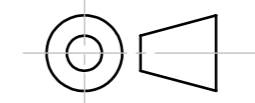

8	7	6	5	4	3	2	1
Rev	Change Doc.	Date	Change Detail				

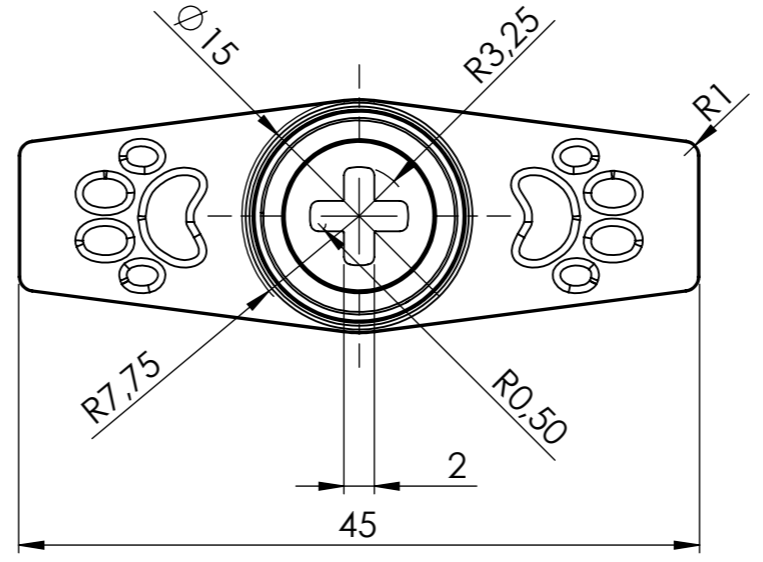
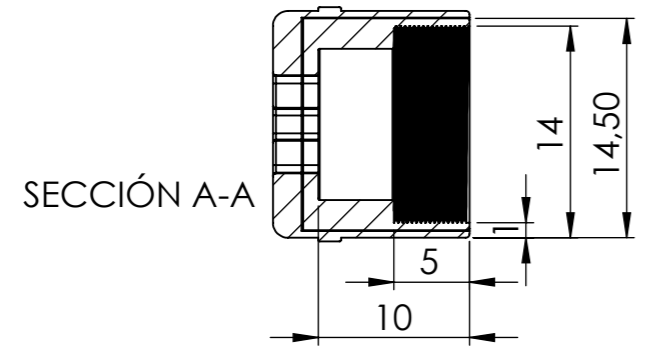
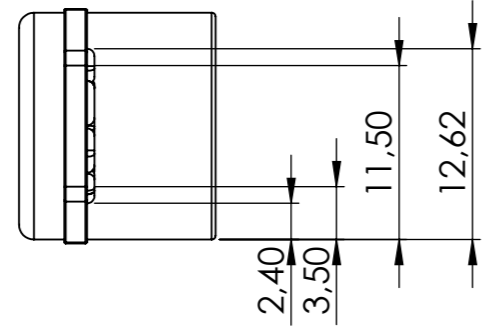
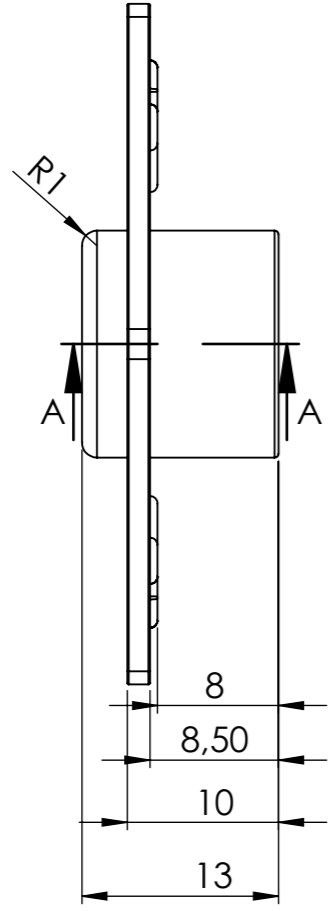

UNLESS OTHERWISE SPECIFIED: DIMENSIONS ARE IN MILLIMETERS SURFACE FINISH: TOLERANCES: LINEAR: ANGULAR:			MATERIAL: Plastic and Rubber	DEBURR AND BREAK SHARP EDGES	DO NOT SCALE DRAWING	REVISION
			FINISH: Shiny	PROJECT: Anivac		
			Notes:		TITLE: Syringe Flanges	
DRAWN	NAME	SIGNATURE	DATE			
CHK'D	Sergio Suanzes					
APPV'D						
designcore undergraduate				PART NO. 2		A3
				SCALE: 2:1		SHEET 2 OF 11

8	7	6	5	4	3	2	1
Rev	Change Doc.	Date	Change Detail				

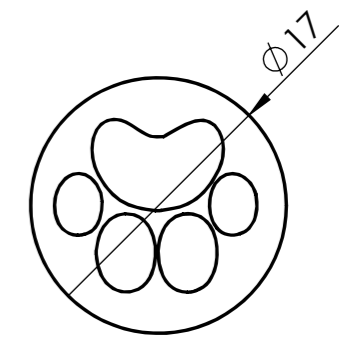
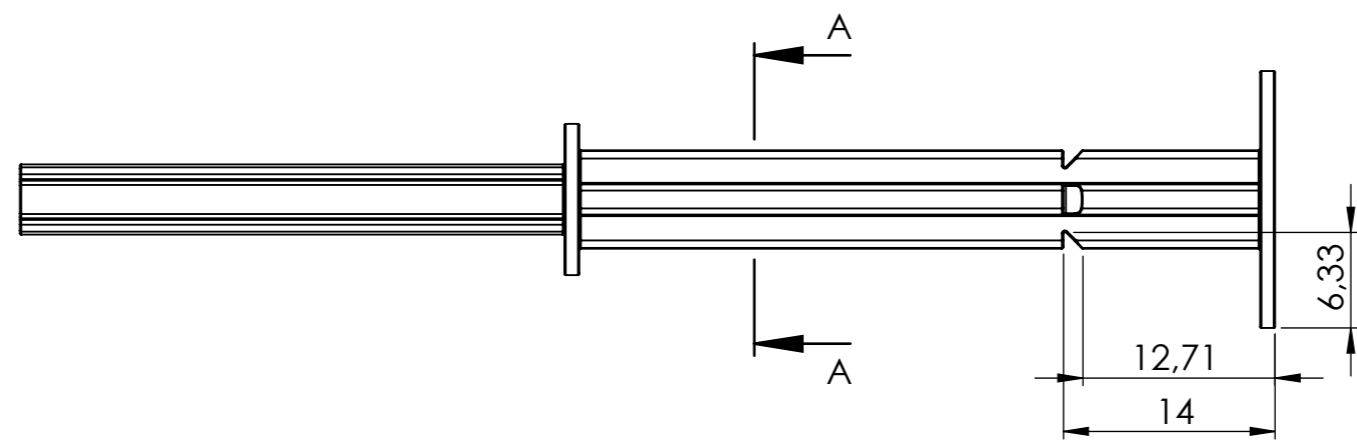
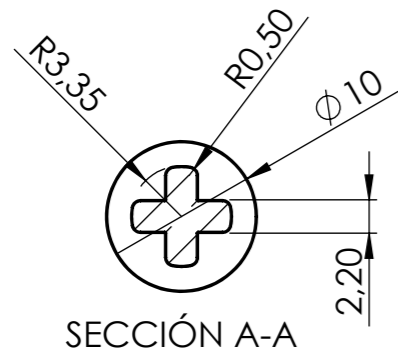
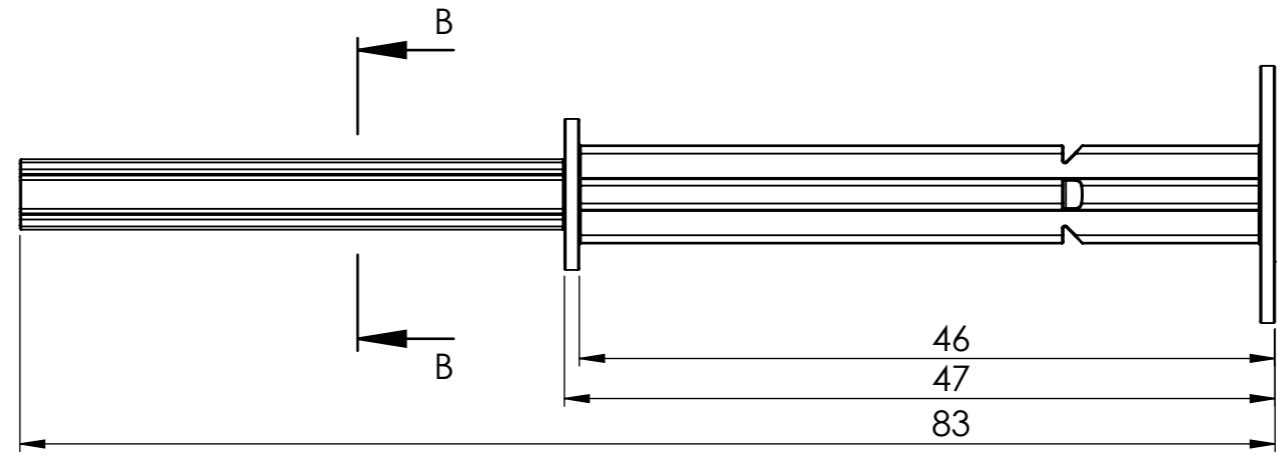
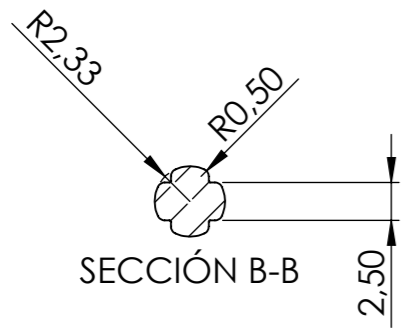

UNLESS OTHERWISE SPECIFIED: DIMENSIONS ARE IN MILLIMETERS SURFACE FINISH: TOLERANCES: LINEAR: ANGULAR:			MATERIAL: Plastic FINISH: Matte		DEBURR AND BREAK SHARP EDGES	DO NOT SCALE DRAWING	REVISION
DRAWN Sergio Suanzes			SIGNATURE		DATE		Notes:
CHK'D			APPV'D		PROJECT: Anivac		
TITLE: Plunger			PART NO. 3		A3		
SCALE: 2:1			SHEET 3 OF 11				

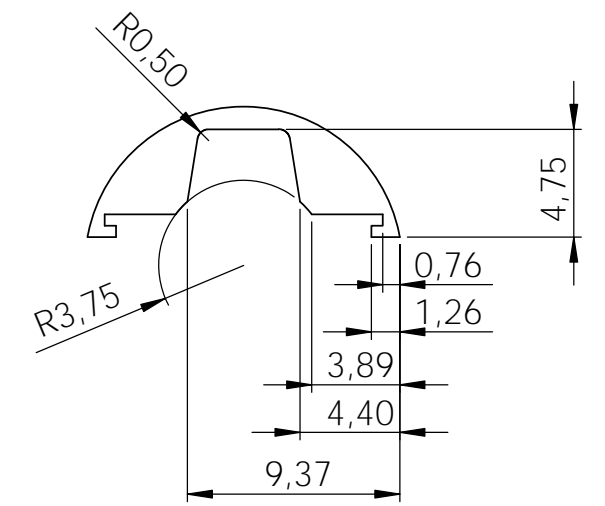
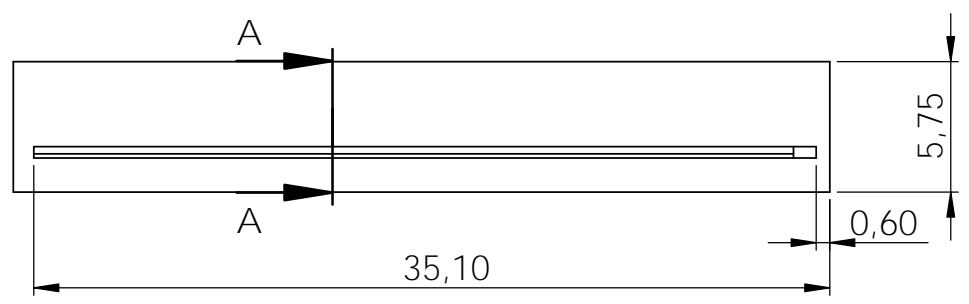
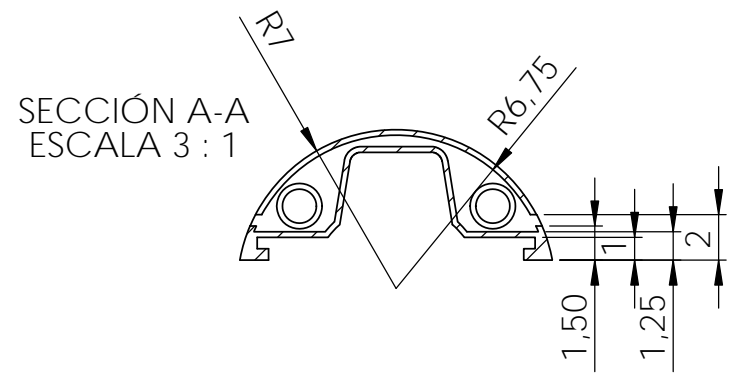
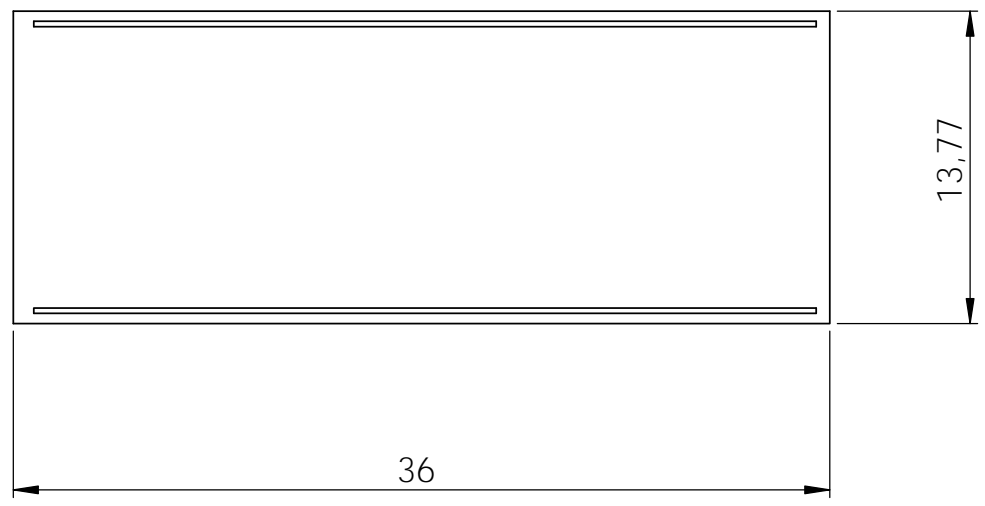

UNLESS OTHERWISE SPECIFIED: DIMENSIONS ARE IN MILLIMETERS SURFACE FINISH: TOLERANCES: LINEAR: ANGULAR:			MATERIAL: Plastic FINISH: Shiny		DEBURR AND BREAK SHARP EDGES	DO NOT SCALE DRAWING	REVISION
DRAWN Sergio Suanzes			SIGNATURE		DATE		Notes:
CHK'D			SIGNATURE		DATE		TITLE: Exterior Capsule Cover
APPV'D			SIGNATURE		DATE		
designcore undergraduate			PART NO. 4		SCALE: 3:1		A3
					SHEET 4 OF 11		

8	7	6	5
Rev	Change Doc.	Date	Change Detail

4	3	2	1
---	---	---	---

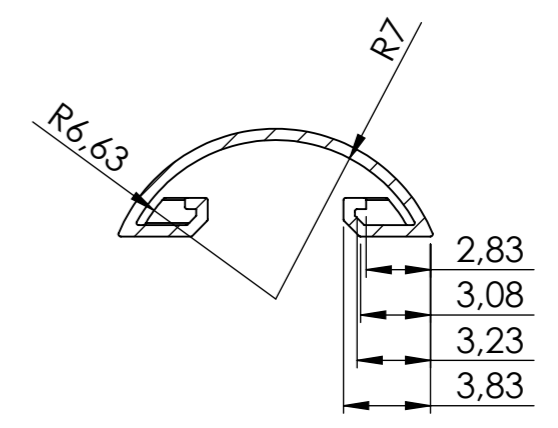
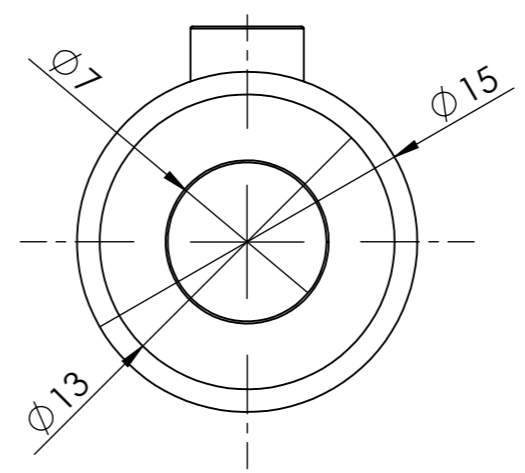
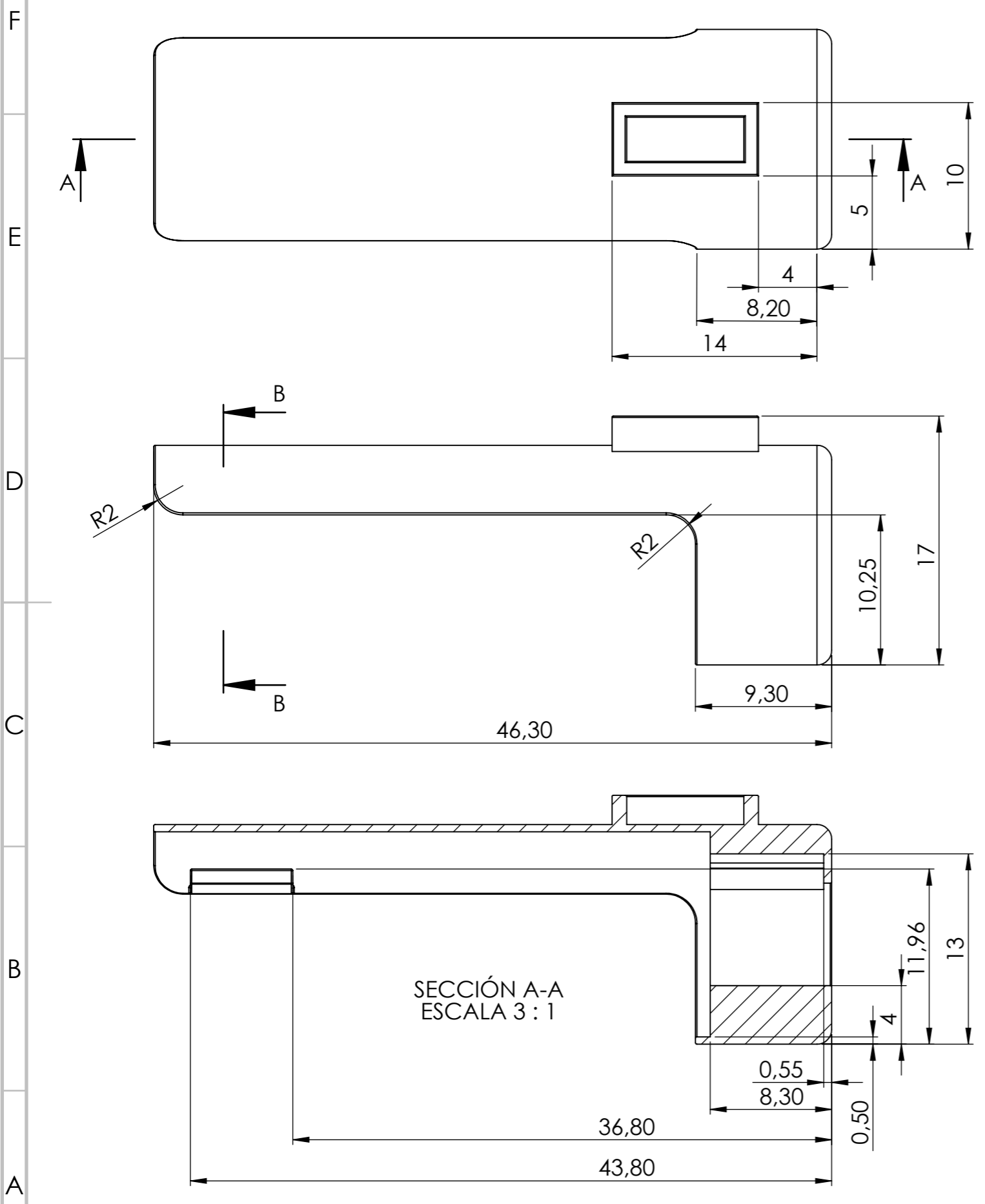

SECCIÓN B-B
ESCALA 3 : 1

UNLESS OTHERWISE SPECIFIED: DIMENSIONS ARE IN MILLIMETERS SURFACE FINISH: TOLERANCES: LINEAR: ANGULAR:		MATERIAL: Plastic FINISH: Shiny	DEBURR AND BREAK SHARP EDGES	DO NOT SCALE DRAWING	REVISION
DRAWN Sergio Suanzes			PROJECT: Anivac		
CHK'D			TITLE: Exterior Needle Cover		
APPV'D			PART NO. 5		A3
designcore undergraduate			SCALE: 3:1		SHEET 5 OF 11

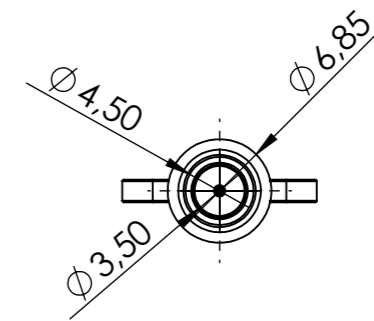
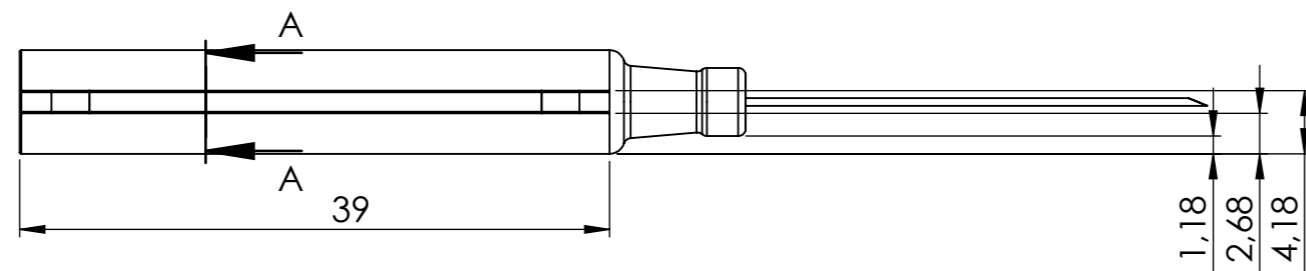
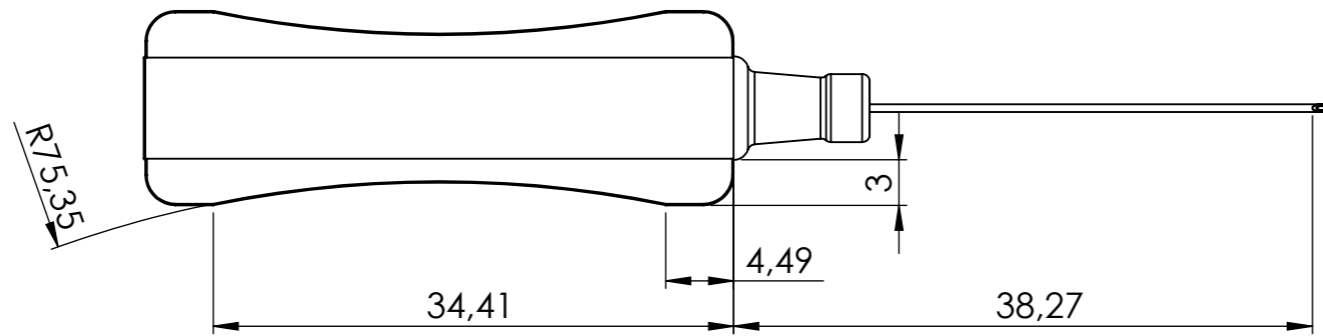

UNLESS OTHERWISE SPECIFIED: DIMENSIONS ARE IN MILLIMETERS SURFACE FINISH: TOLERANCES: LINEAR: ANGULAR:		MATERIAL: Glass		DEBURR AND BREAK SHARP EDGES		DO NOT SCALE DRAWING		REVISION			
		FINISH: Translucent				PROJECT: Anivac					
				Notes:		TITLE: Capsule with Integrated Needle					
DRAWN		NAME				SIGNATURE		DATE		PART NO. 6	
CHK'D										A3	
APPV'D								SCALE: 2:1			
						SHEET 6 OF 11					

8	7	6	5	4	3	2	1
Rev	Change Doc.	Date	Change Detail				

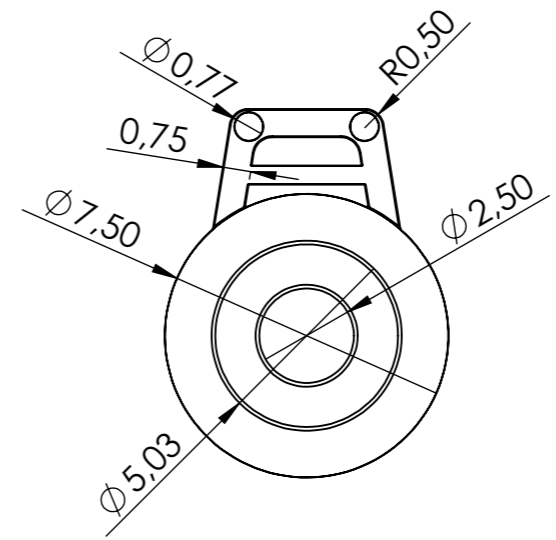
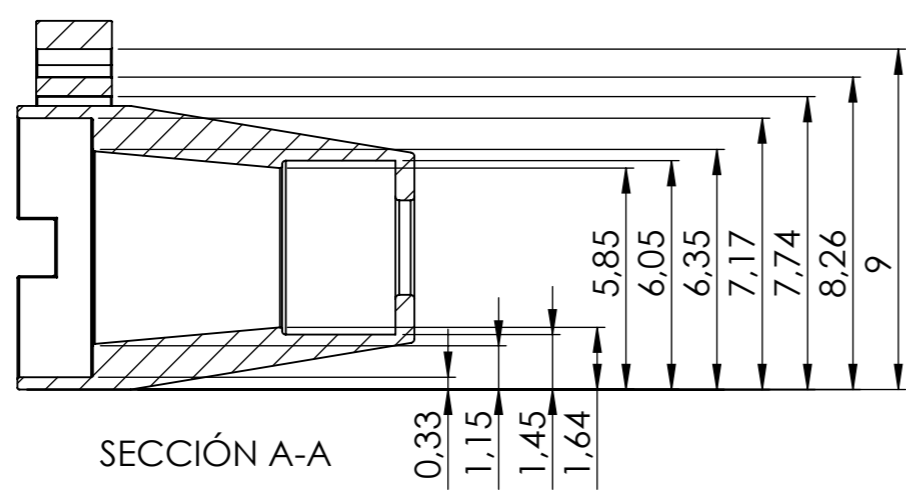
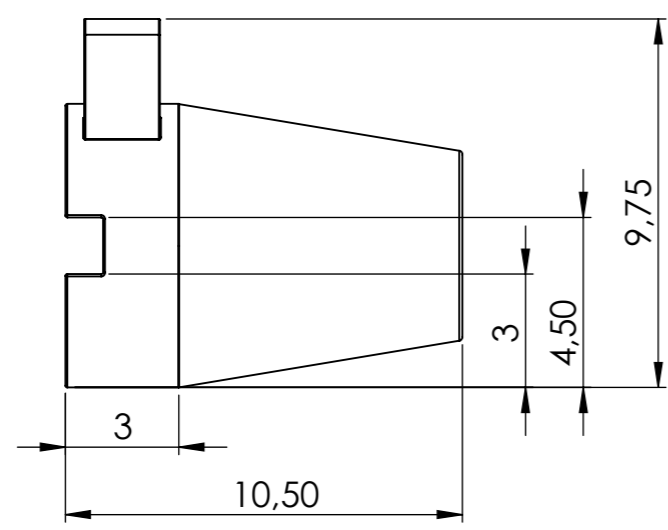
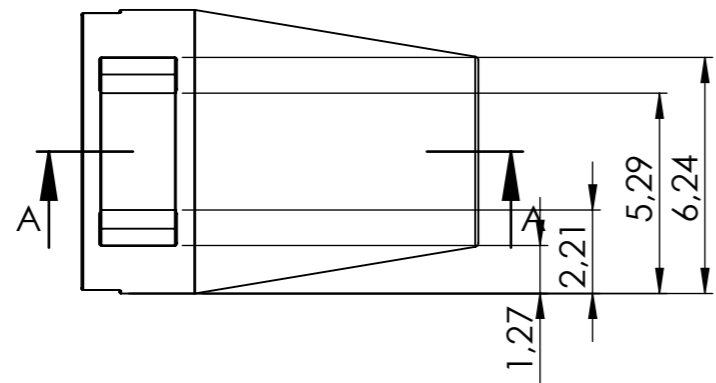

UNLESS OTHERWISE SPECIFIED: DIMENSIONS ARE IN MILLIMETERS SURFACE FINISH: TOLERANCES: LINEAR: ANGULAR:		MATERIAL: Plastic FINISH: Translucent	DEBURR AND BREAK SHARP EDGES	DO NOT SCALE DRAWING	REVISION
DRAWN Sergio Suanzes		SIGNATURE	DATE	PROJECT: Anivac	
CHK'D		Notes:		TITLE: Needle Plastic Protection Base	
APPV'D		designcore undergraduate		PART NO. 7	A3
				SCALE: 5:1	SHEET 7 OF 11

F
E
D
C
B
A

F
E
D
C
B
A

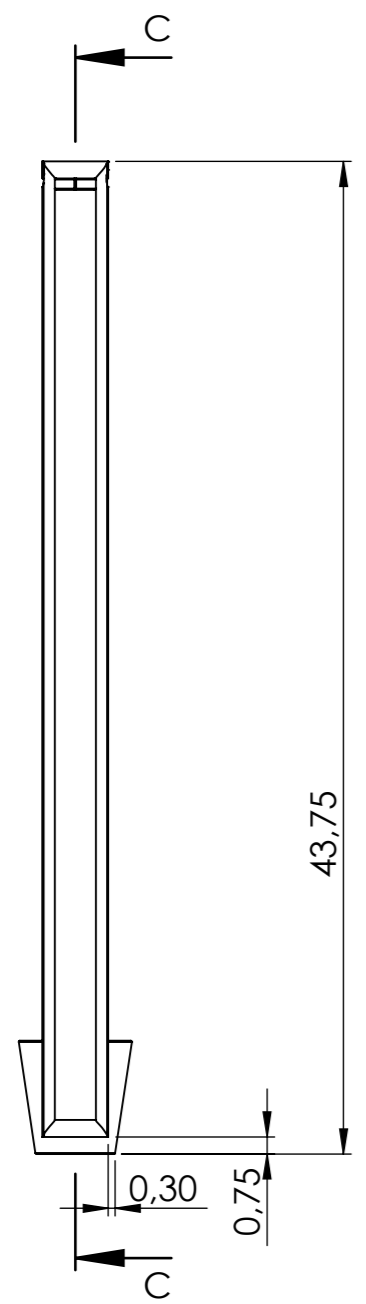

SECCIÓN C-C
ESCALA 3:1

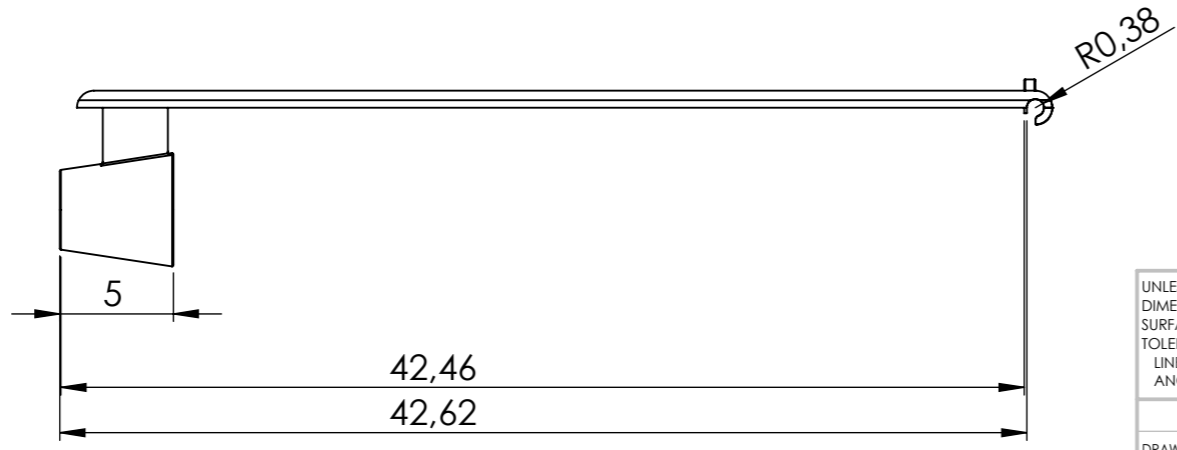
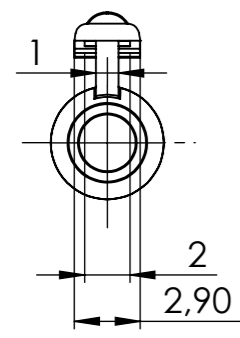
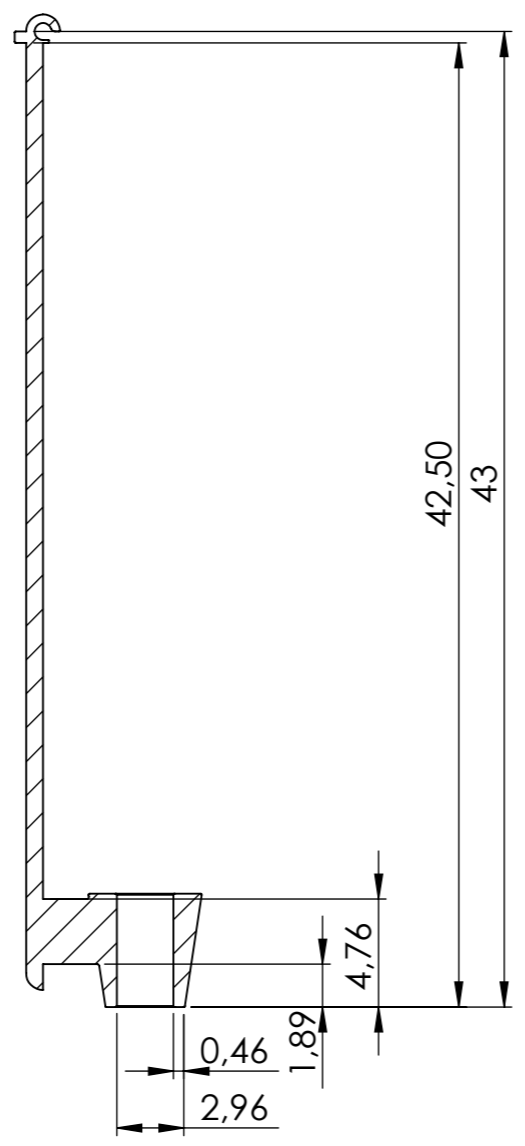

UNLESS OTHERWISE SPECIFIED: DIMENSIONS ARE IN MILLIMETERS		MATERIAL: Plastic		DEBURR AND BREAK SHARP EDGES		DO NOT SCALE DRAWING		REVISION	
SURFACE FINISH:		FINISH: Matte				PROJECT: Anivac			
TOLERANCES: LINEAR: ANGULAR:						TITLE: Needle Tip Protection			
DRAWN Sergio Suanzes		SIGNATURE		DATE		Notes:		PART NO. 8	
CHK'D								A3	
APPV'D								SCALE: 3:1	
designcore undergraduate						SHEET 8 OF 11			

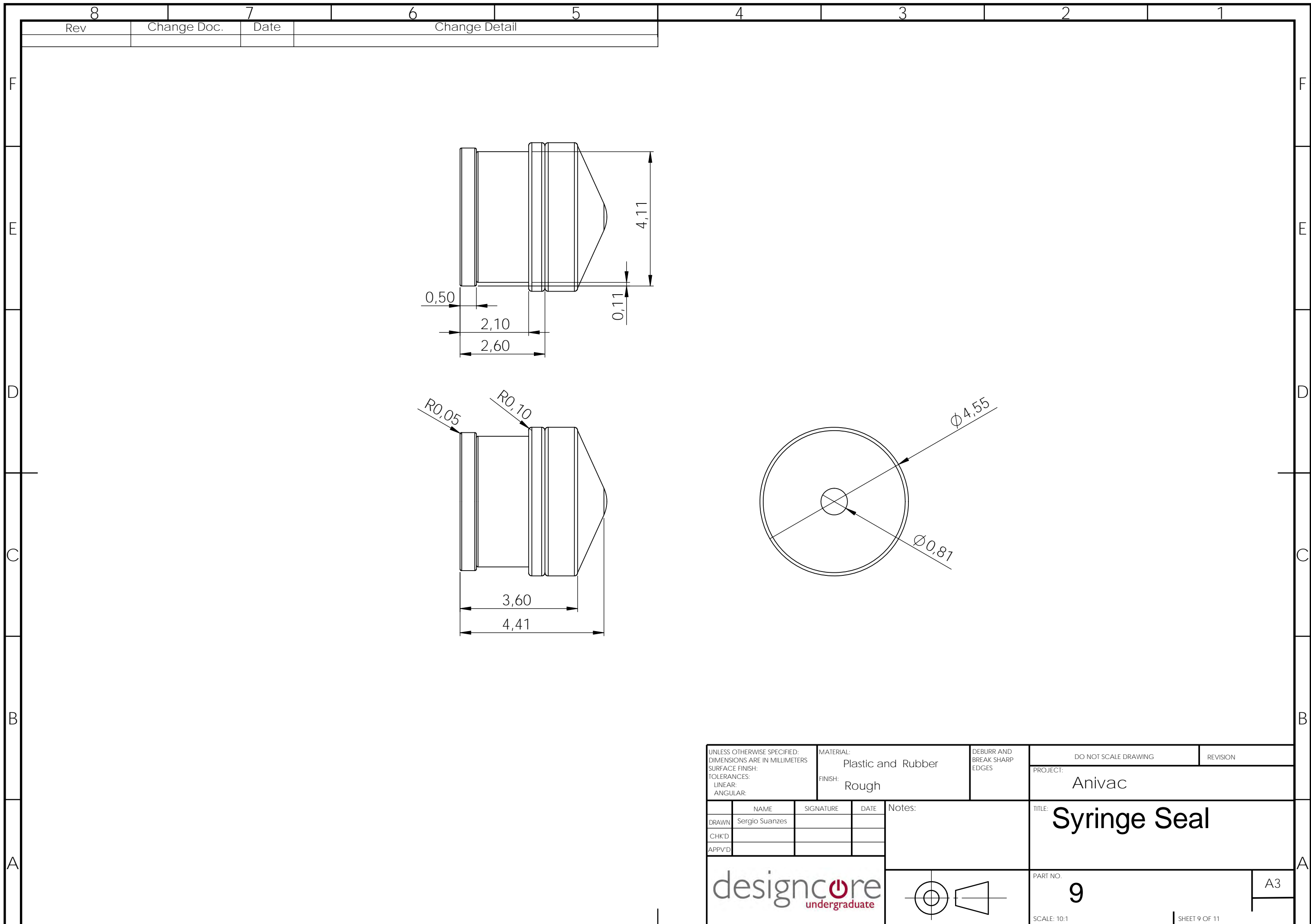

8	7	6	5	4	3	2	1
Rev	Change Doc.	Date	Change Detail				

UNLESS OTHERWISE SPECIFIED: DIMENSIONS ARE IN MILLIMETERS SURFACE FINISH: TOLERANCES: LINEAR: ANGULAR:			MATERIAL: Plastic and Rubber FINISH: Rough		DEBURR AND BREAK SHARP EDGES	DO NOT SCALE DRAWING	REVISION												
					PROJECT: Anivac														
					TITLE: Syringe Seal														
<table border="1"> <tr> <th>NAME</th> <th>SIGNATURE</th> <th>DATE</th> </tr> <tr> <td>DRAWN Sergio Suanzes</td> <td></td> <td></td> </tr> <tr> <td>CHK'D</td> <td></td> <td></td> </tr> <tr> <td>APPV'D</td> <td></td> <td></td> </tr> </table>			NAME	SIGNATURE	DATE	DRAWN Sergio Suanzes			CHK'D			APPV'D			Notes:		PART NO. 9		A3
NAME	SIGNATURE	DATE																	
DRAWN Sergio Suanzes																			
CHK'D																			
APPV'D																			
					SCALE: 10:1		SHEET 9 OF 11												

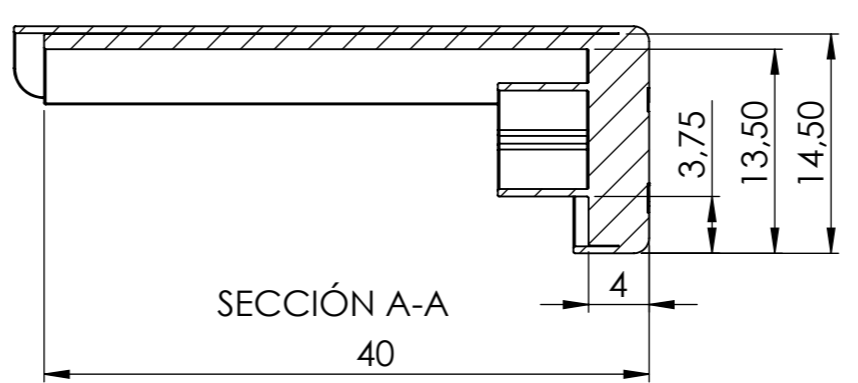
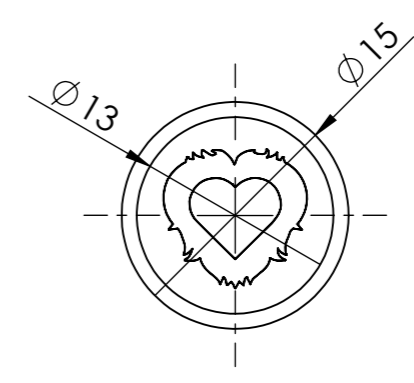
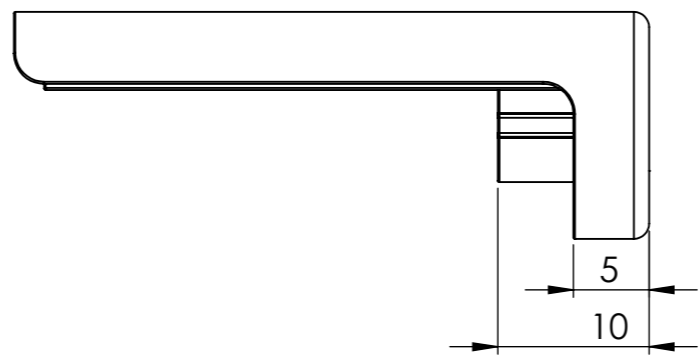
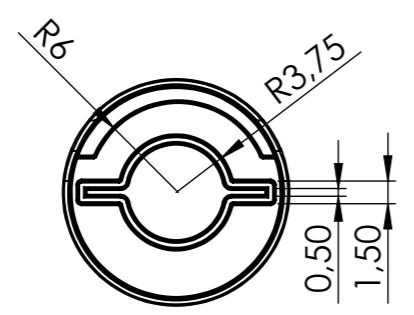
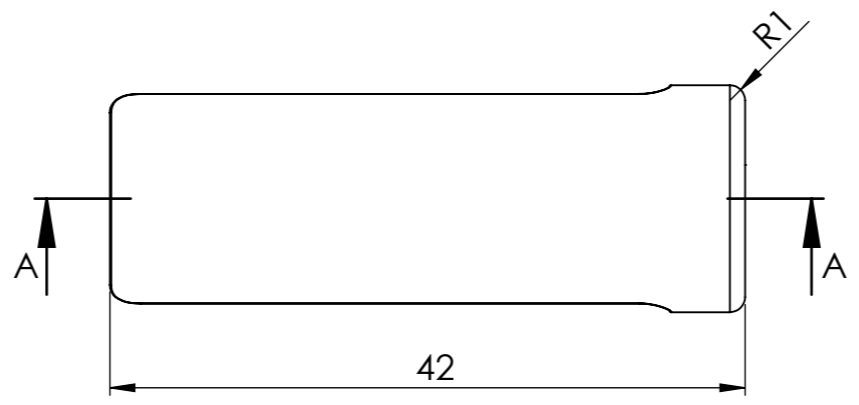

UNLESS OTHERWISE SPECIFIED: DIMENSIONS ARE IN MILLIMETERS SURFACE FINISH: TOLERANCES: LINEAR: ANGULAR:			MATERIAL: Plastic FINISH: Shiny		DEBURR AND BREAK SHARP EDGES	DO NOT SCALE DRAWING	REVISION
					PROJECT: Anivac		
					TITLE: Plastic Exterior Cap		
					PART NO. 10		A3
					SCALE: 2:1		SHEET 10 OF 11

NAME	SIGNATURE	DATE
DRAWN Sergio Suanzes		
CHK'D		
APPV'D		

Notes:

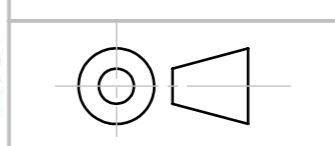

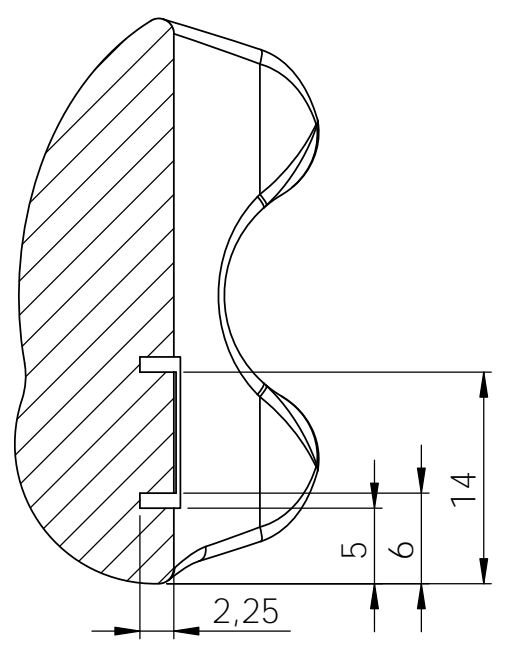

SECCIÓN A-A

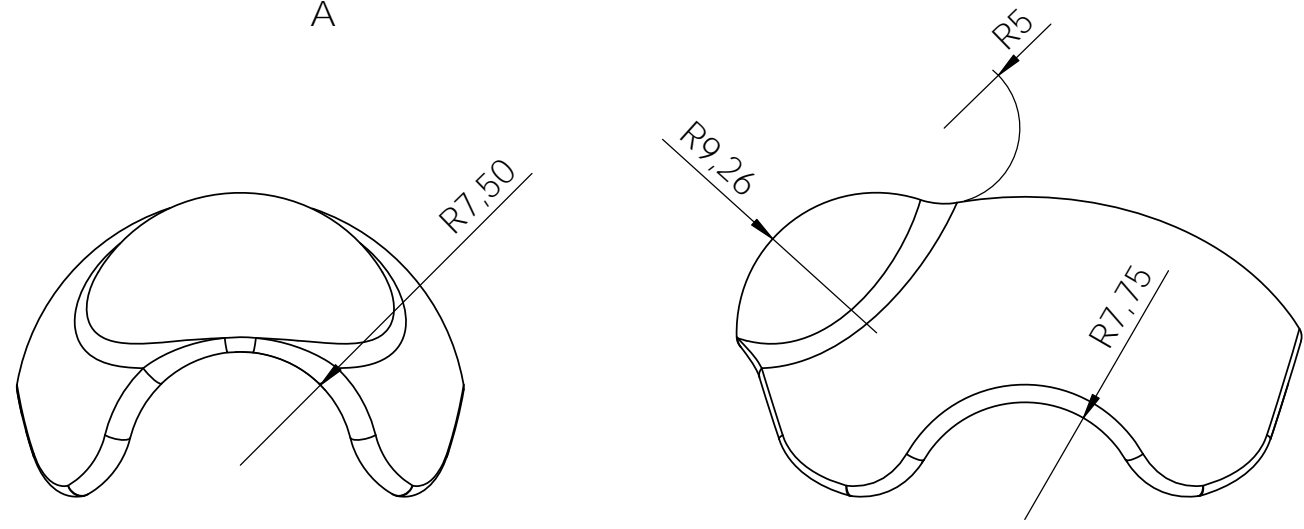
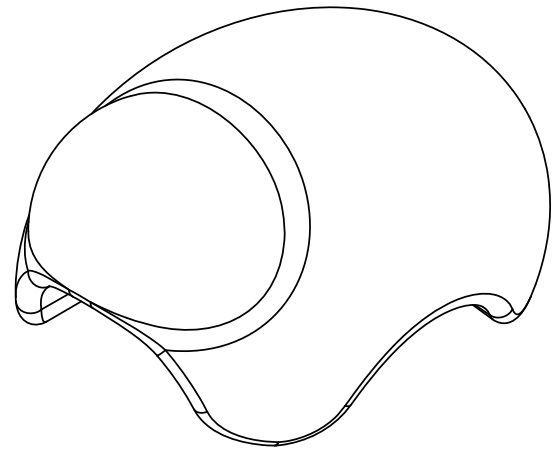
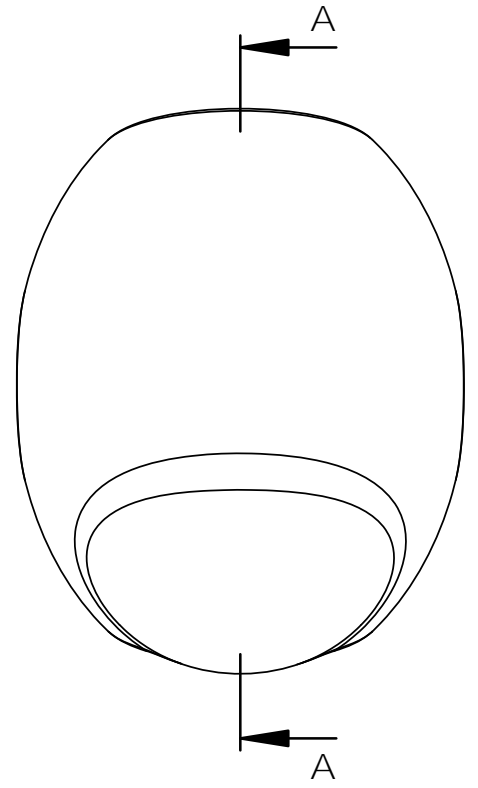

UNLESS OTHERWISE SPECIFIED: DIMENSIONS ARE IN MILLIMETERS SURFACE FINISH: TOLERANCES: LINEAR: ANGULAR:			MATERIAL: Plastic FINISH: Painted		DEBURR AND BREAK SHARP EDGES	DO NOT SCALE DRAWING	REVISION
					PROJECT: Anivac		
					TITLE: Syringe Toy		
DRAWN Sergio Suanzes		SIGNATURE		DATE	Notes:		
CHK'D							
APPV'D							
designcore undergraduate					PART NO. 11		A3
					SCALE: 2:1		SHEET 11 OF 11

ANNEX 6

Banner



Sergio Suanzes Mazon

ANIVAC

"Dreaming the impossible"



Anivac



Anivac

Needle phobia is a serious medical condition that affects approximately 10% of the adult population. The people affected by this condition avoid medical care to reduce the chances of getting in contact with any type of needles.

Needle phobia usually stems from a traumatic injection at a young age, usually between 3 to 10 years old. During this period vaccination is the most common needle-related procedure that children undergo.

Anivac is a new syringe adapted to deliver young children a positive, interactive and fun experience during vaccination in order to reduce the prevalence of stressful and painful situations during vaccine delivery.

How does it work?



1. Playing

The children receive a toy replica of the syringe before the injection. With this replica, children can interact, explore and discover the medical world and needle procedures in a stress free environment.

2. Exposure

Through fun and games the children can learn about the vaccination process and get used to the device that will be employed. This previous experience can help reduce stress and fear when the real puncture happens.

3. Injection

In the hospital, the product acts as a link between the child and the doctor, it establishes a sense of familiarity. The doctor is not a total stranger anymore, and the child can relate to them in a certain way, as both of them have the same "toy". This lets the doctor employ traditional stress reducing techniques in a more effective way.

4. Reward

After the injection, the child can take the small animal toy from the doctor and add it to their home replica. They come in different themes so they can collect them, making visits something to look forward to.

Innovation

The Anivac is a product that functions as a medical syringe for childrens vaccination. It's a plastic device that can be loaded with a pre-filled 0.5mL capsule with an integrated needle. The plastic device covers the needle and hides it from the child's sight. With the device comes a little toy that can be chosen by the child before the vaccination, and can be gifted to them after, to create an interactive and fun environment. The aim of this product is to reduce the prevalence of needle phobia, by reducing the chance of traumatic events related to needles during childhood.

The Syringe

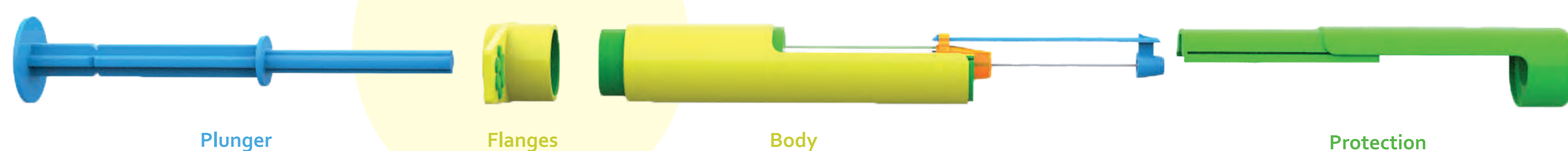

This space is not seen but needed for the roller