



VILNIUS GEDIMINAS TECHNICAL UNIVERSITY
FACULTY OF CIVIL ENGINEERING
DEPARTMENT OF CONSTRUCTION TECHNOLOGY AND MANAGEMENT

Ignacio María Veguer Alfonso

**CONSTRUCTION DESIGN OF MULTI-DWELLING BUILDING AT
MAUDYKLOS STR. IN VILNIUS**

Bachelor thesis

Language: English

Vilnius, 2012

VILNIUS GEDIMINAS TECHNICAL UNIVERSITY
FACULTY OF CIVIL ENGINEERING
DEPARTMENT OF CONSTRUCTION TECHNOLOGY AND MANAGEMENT

APPROVED
Head of Department

(signature)

Edmundas K. Zavadskas
(name, surname)

(date)

Ignacio María Veguer Alfonso

**CONSTRUCTION DESIGN OF MULTI-DWELLING BUILDING AT
MAUDYKLOS STR. IN VILNIUS**

Bachelor thesis

Language: English

Supervisor dr. Jonas Saparauskas
(name, surname) (signature) (date)

Consultant Remigijus Salna
(name, surname) (signature) (date)

Vilnius, 2012



VILNIUS GEDIMINAS TECHNICAL UNIVERSITY

FACULTY OF CIVIL ENGINEERING

DEPARTMENT OF CONSTRUCTION TECHNOLOGY AND MANAGEMENT

Ignacio María Veguer Alfonso

Construction design of the ELNIAKAMPIO NAMAI at Maudyklos gatve 5 in Valakampiai
district in Vilnius (Lithuania)

Final thesis work
Supervisor: Dr. Jonas Saparauskas
Consultant: Dr. Remigijus Salna

Vilnius, 2012

INDEX

1. ARCHITECTURAL PART	4
1.1 INTRODUCTION	4
1.2 TERRITORY AND LOCATION	4
1.3 CONSTRUCTION AND ARCHITECTURE.....	5
1.3.1 DISTRIBUTION	5
1.3.2 STRUCTURE	6
1.3.3 FACADES.....	8
1.3.4 INTERIOR AND EXTERIOR FINISHES OF BUILDING	9
1.3.5 SERVICES OF BUILDING	11
2. CONSTRUCTIONAL PART	12
2.1 DESIGN OF MONOLITHIC ROOF SLAB	12
2.1.1 DESIGN DATA	12
2.1.2 DESIGN OF MATERIAL CHARACTERISTICS	12
2.1.3 CALCULATING LOADS.....	13
2.2 STRUCTURAL ANALYSIS OF SLAB.....	16
2.2.1 ANALYSIS	16
2.2.2 RESULTS.....	16
2.2.3 DESIGN OF SLAB REINFORCEMENT	17
3. TECHNOLOGICAL CARDS	22
3.1 TECHNOLOGICAL CARD OF GYPSUM PLASTERBOARD PARTITIONS	22
3.1.1 GENERAL DESCRIPTION.....	22
3.1.2 CONSTRUCTION PROCESS.....	23
3.1.3 INSTALLATION SEQUENCE.....	25
3.1.4 ORGANIZATION OF WORKS	26
3.1.5 HUMAN SAFETY	27
3.1.6 MECHANICS, MATERIALS AND TOOLS	27
3.1.7 QUALITY CONTROL.....	27
3.1.8 TECHNICAL ECONOMICS INDICATORS	28
3.1.9 SOME DETAILS.....	28
3.1.10 BUDGET	31
3.2 TECHNOLOGICAL CARD OF VENTILATED FAÇADE (CERAMIC)	33
3.2.1 GENERAL DESCRIPTION.....	33

3.2.2 CONSTRUCTION PROCESS.....	34
3.2.3 CONSTRUCTION SEQUENCE.....	36
3.2.4 ORGANIZATION OF WORKS.....	37
3.2.5 HUMAN SAFETY.....	38
3.2.6 MACHINES, MATERIALS AND TOOLS.....	38
3.2.7 QUALITY CONTROL.....	38
3.2.8 SOME DETAILS.....	39
3.2.9 BUDGET.....	42
3.2.10 TECHNICAL ECONOMICS INDICATORS.....	42
4. ORGANIZATION PART.....	43
4.1 MASTERPLAN.....	43
4.1.1 DESCRIPTION.....	43
4.1.2 SELECTION OF TOWER CRANE.....	43
4.1.3 SETTING OF DANGEROUS ZONE.....	46
4.1.4 TEMPORARY ROAD.....	52
4.1.5 TEMPORARY STORAGE BUILDINGS AND SITES.....	52
4.1.6 TEMPORARY BUILDINGS.....	53
4.1.7 TEMPORARY BUILDINGS.....	53
4.1.8 CONSTRUCTION SITE LIGHTING.....	55
4.1.9 TEMPORARY WATER SUPPLY.....	55
4.1.10 TEMPORARY SEWERAGE.....	56
4.1.11 FENCE OF CONSTRUCTION SITE.....	56
4.1.12 GENERAL REQUIREMENTS OF LABOR SAFETY.....	56
4.1.14 REQUIREMENTS OF ENVIRONMENTAL PROTECTION.....	58
4.1.15 REQUIREMENTS OF FIRE PROTECTION.....	58
4.2 ORGANIZATION.....	59
4.2.1 TABLES OF MACHINERY AND WORKFORCE.....	59
BIBLIOGRAPHY.....	61
Websites:.....	61

1. ARCHITECTURAL PART

1.1 INTRODUCTION

Elniakampis apartment house is located in the forest on a quiet Elniakampis Street in a prestigious district of Vilnius – Valakampiai. A small three-storey 17-apartment house is designed to let in the maximum amount of natural light.

The layout of the apartments is both convenient (from 34,90 m² to 140,20 m²) and practical. Each apartment comes with a box room, parking place under the house and economical gas heating. There is a possibility to install fireplaces in each apartment.

A bus stop (No. 15) is just 200 m away from the house. Just a couple of kilometres away you would find Nemencine Road, leading you to the shopping center, Sauletekis University campus and Baltic-American Clinic that provides medical services 24 hours a day. All the infrastructure of Antakalnis district is nearby.

Surfaces: - Building area: 671.47 m²

- Plot: 1200 m²

1.2 TERRITORY AND LOCATION

The land plot is in Vilnius city Antakalnis elderate, at the beginning of Elniakampis Street (coming from Svajonių Street). Elniakampis Street is on the one side of the land plot and an undeveloped forest territory – on the other. The land plot does not border any other plots, except for the state land. The area of the land plot – 1200 m². The undeveloped part of the plot will be laid with blocks, pavement tiles and lawns.

Access to the territory is from Elniakampis Street.



Figure 1. Location

1.3 CONSTRUCTION AND ARCHITECTURE

1.3.1 DISTRIBUTION

The house will have 17 apartments spread over three floors. Each floor is made with a different distribution, the first floor has two apartments of 54.1 m², one of 53.4 m², two of 63.7 m², one of 55.1 m, and one of 34.9 m². The second floor contains one of 90 m², one of 54.1 m², one of 52.3 m², one of 55 m², and two of 63.6 m². The third floor contains one of 49.6 m², one of 68 m², one of 53.5 m², and the most important flat with 140.2 m². The different distributions are in figure 2.

The ground floor has a car park for 19 cars surrounded by a hedge. The entrances to parking spaces are open, without gates.

The apartments are accessible through the staircase and an elevator. The elevator of 1125 kg carrying capacity has been designed and it has four stops. Lift doors, some apartment and all common area doors are 1 m wide, i.e. accessible for the disabled. Access from the lift to the parking lot has a 5 cm sloping ramp.

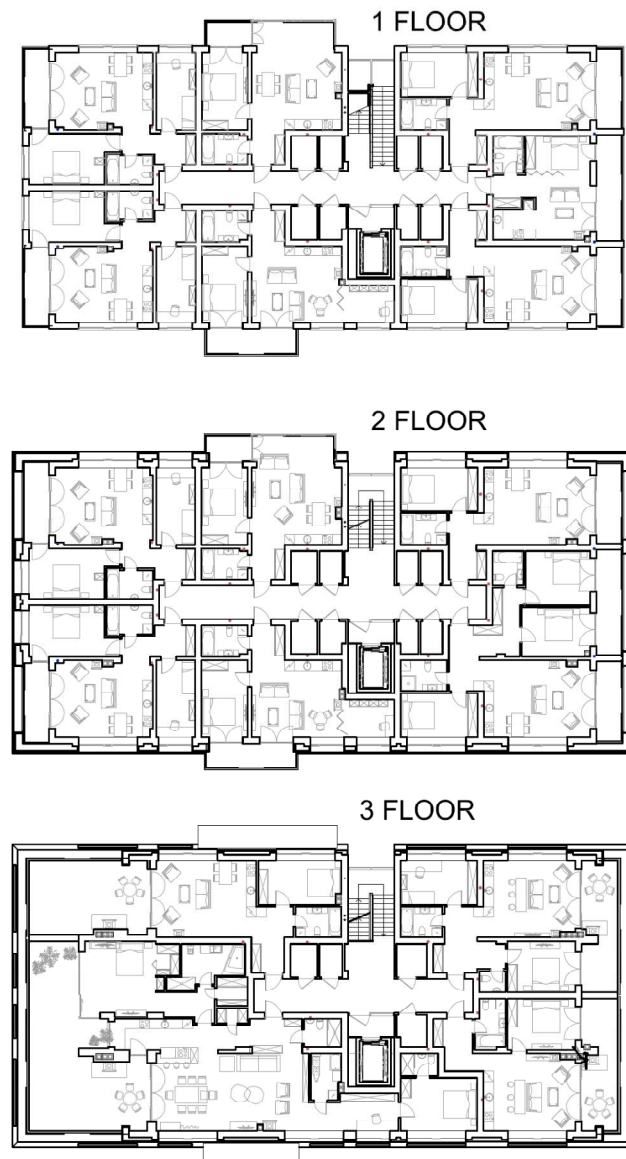

Figure 2.
Distribution

1.3.2 STRUCTURE

FUNDATION

After the geotechnical study and testing of the ground it was decided that the foundation of the building was to be on piles of reinforced concrete with pile cap. Figure 3

The reinforcement are shaped as if they were cages, the longitudinal reinforcement bars are made up of evenly placed around the perimeter of the section, and the armed cross is formed by a spiral hoop or hoops of 6 mm round. section, with a spacing of 20 cm. The outer diameter of the belt is equal to the diameter of the pile, minus 8 cm, thus obtaining a minimum thickness of 4 cm. The number of bars and the diameter thereof is calculated according to the load that has to bear the pile.

The concrete used for the execution of piles concreted "in situ" shall meet the requirements of the Spanish current Structural Concrete (EHE-2008), the effect of Instruction for Receiving Cement, and a number of specific requirements for the case of piles concreted "in situ", which are: The maximum aggregate size not exceeding 32 mm, or quarter round the longitudinal separation, by selecting the smaller of the two dimensions. The cement content is higher than 350 kg/m³, is recommended to be 400 kg / m³. The content of fine particles in the concrete, including cement and other fine materials, shall be between 400 kg/m³ and 550 kg/m³. The water / cement ratio and the use of additives will be determined by the current Structural Concrete (EHE-2008), must be approved by the Director of Work. The minimum resistance of the concrete shall be in the Project or otherwise directed by the Director of Works, not being less than that specified by the EHE. Furthermore it should not be attacked by water.

The piles were decapitated, thereby eliminating the concrete always of low quality remains at the top. So reinforcements are exposed to intertwine the pile cap. The length of the reinforcement must allow post-heading, are protruding from the pile about 50 cm. Longitudinal reinforcements of the pile are spliced by a minimum overlap of 40 cm., Are welded or wired throughout its length. If you use proper fencing as a transverse reinforcement, the closures are made for overlap of 8 cm or more and are welded or wired.

The overlap is alternated for successive fences. Trusses are attached firmly to form a cage that supports concreted. Each pile is concreted at once without interrupting the operation, not supported concrete joints. At the end of the pile should be concreted to a height greater than the final, which exceeds concrete is demolished when it has set. Do not effect the displacement of piles driven in or yokes in an area less than 3 m. around the pile until the concrete has a minimum strength of 30 kg/cm², according to previous tests. Decapitated after the ground piles protrude sufficiently to allow embedment in concrete of at least 5 cm to the pile cap.

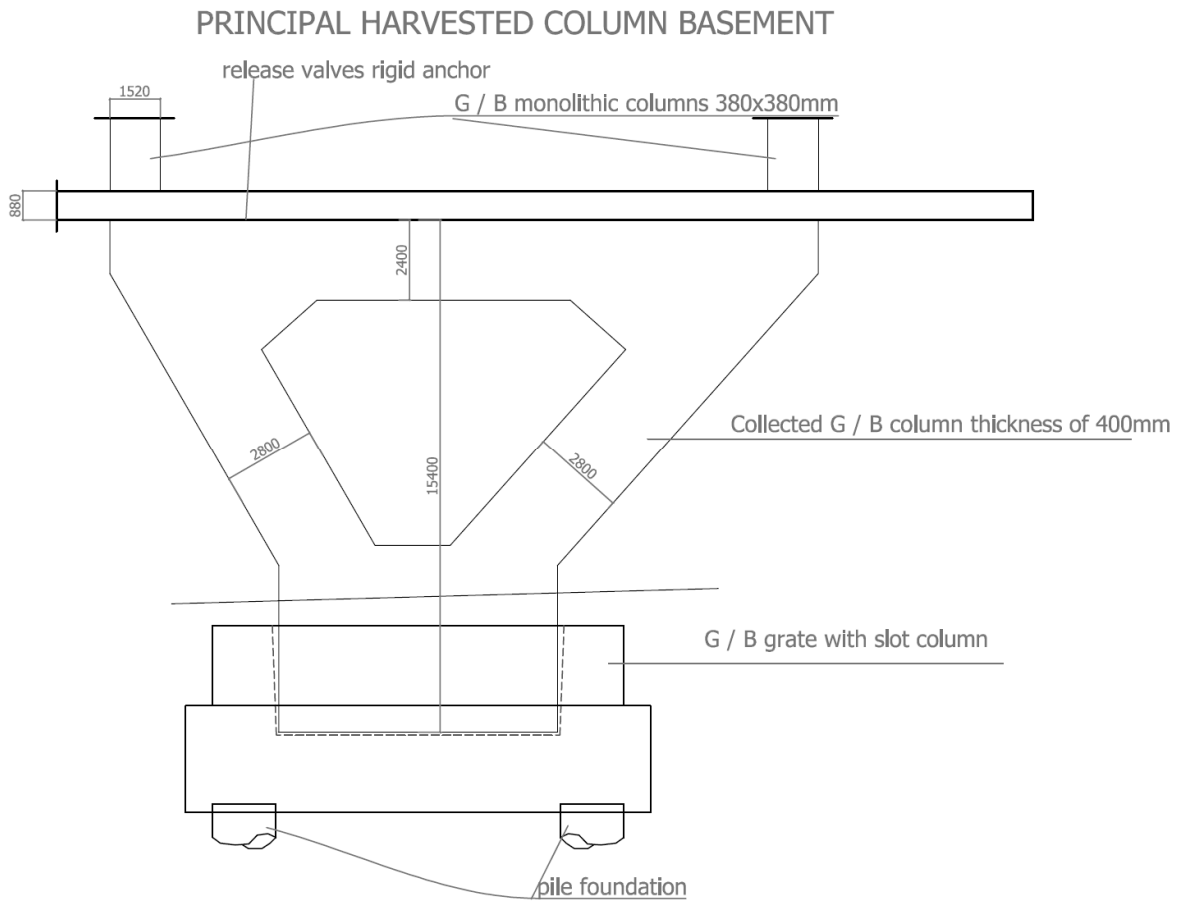

Figure 3. Detail of fundation

COLUMNS

Monolithic columns of rectangular and square cross-section (figure 4) made of reinforced concrete.

The concrete we are going to use will be C25/30 (project) and C20/25 in the roof floor and C30/37 in foundation columns.

The iron for our columns will be S275J.

The column measures are: 38 x 38 cm.

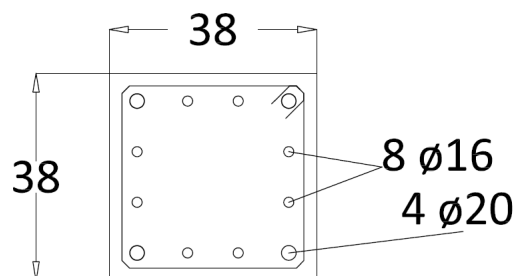

Figure 4. Detail of colum

SLABS

Our slabs are built with reinforced concrete with a reinforced top and a reinforced bottom. Also will contain reinforcements in areas of bending moments. All slabs will be of 22 cm of thickness. Figure 5.

The concrete will be C20/25 in all floors (project).

The iron will be S275J.

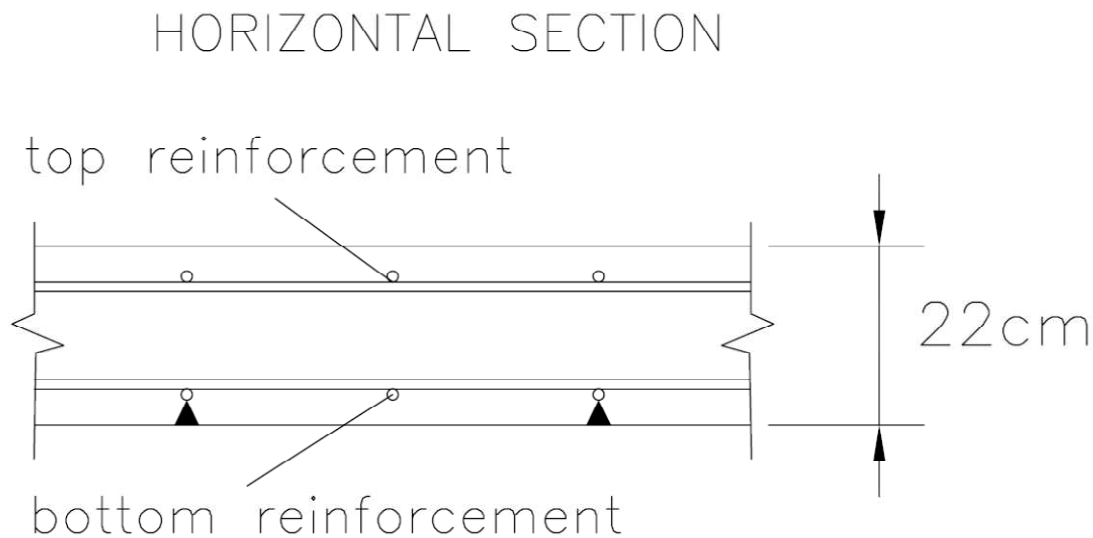

Figure 5. Detail of slab

1.3.3 FACADES

There are two kinds of façade. Ventilated façade of ceramic finishing, and inclined ventilated façade with slate finishing. Both are built of blocks, with exterior thermal insulation composed of non-combustible mineral wool. Ventilated façade with ceramic finishes will be explained in one of technological cards. Figure 6.

Staircase windows made of aluminum frames. On all floors, dark grey.

Apartment window frames made of wood, twin-chamber glazing with selective internal glass. Window frames are dark grey on the outside. Clear glass. To ensure natural ventilation, all window frames have air vents.

External wall element

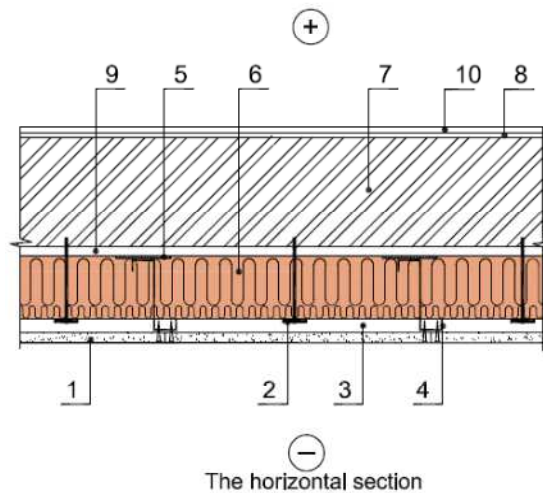

- 1 - Finish (plaster, or ceramic. Plate)
- 2 - Pin
- 3 - Air space, 20 ... 30 mm
- 4 - Metal Profile
- 5 - Interim
- 6 - Thermal insulation, 180 mm
- 7 - Lightweight masonry blocks, 380 mm
- 8 - Interior plaster
- 9 - Waterproof mortar
- 10 - Interior revoque

Figure 6. Detail of facade

1.3.4 INTERIOR AND EXTERIOR FINISHES OF BUILDING

Doors of the apartments are high-security type, with two locks; imitation wood finish, with a peephole.

The floor finishes are parquet inside of apartments except kitchens and bathrooms. In that rooms will be ceramic gres tiles in different colors. And in the terraces and balconies will be stone tiles.

Parking lot laid with concrete blocks, ceiling covered with decorative plaster, glass doors; marking done with reflective paint.

Maintenance areas, staircases and corridors laid with stone tiles, walls and ceiling daubed and painted. A boxroom designed for every apartment.

Interior walls of blocks will be plastered and painted. There are some plasterboard partitions that will be painted too. One of the technological cards is about plaster boards partitions. In this technological card, will be explained everything.

The roof is laid with bituminous adhesive covering with powder, brown. Chimneys are tin.

LEGEND OF ROOMS 2 FLOOR

2-1	Apartment	90.00m ²	2-5	Apartment	63.60m ²
2-1.01	corridor	7.90	2-5.01	Corridor	7.20
2-1.02	kitchen	11.30	2-5.02	kitchen	10.30
2-1.03	Room	18.00	2-5.03	Room	16.00
2-1.04	Room	11.90	2-5.04	Room	14.70
2-1.05	bathroom	5.00	2-5.05	Room	10.60
2-1.06	Room	12.00	2-5.06	bathroom	4.80
2-1.07	Room	12.80	2-5.07	balcony	7.80
2-1.08	bathroom	3.70	2-6	Apartment	63.60m ²
2-1.09	corridors	7.40	2-6.01	Corridor	7.20
2-1.10	balcony	10.00	2-6.02	kitchen	10.30
2-1.11	balcony	7.80	2-6.03	Room	16.00
			2-6.04	Room	14.70
			2-6.05	Room	10.60
			2-6.06	bathroom	4.80
			2-6.07	balcony	7.80
2-2	Apartment	54.10m ²		Other room	41.10m ²
2-2.01	corridor	7.90	2-H1	hall	38.30
2-2.02	kitchen	11.30	2-S1.1	pantry	0.70
2-2.03	Room	18.00	2-S2.1	pantry	00.30
2-2.04	Room	11.90	2-S3.1	pantry	12.40
2-2.05	bathroom	5.00	2-S4.1	pantry	00.30
2-2.06	balcony	7.80	2-S5.1	pantry	12.40
2-3	Apartment	53.30m ²	2-S6.1	pantry	12.40
2-3.01	corridors	4.00	2-S7.1	pantry	00.30
2-3.02	kitchen	8.60	2-S1.2	pantry	4.50
2-3.03	Room	16.00	2-S2.2	pantry	20.02
2-3.04	Room	12.80	2-S3.2	pantry	2.50
2-3.05	bathroom	5.00	2-S4.2	pantry	30.02
2-3.06	Room	6.90	2-S5.2	pantry	2.70
2-3.07	balcony	8.30	2-S6.2	pantry	2.70
2-4	Apartment	55.00m ²	2-S7.2	pantry	20.02
2-4.01	corridors	4.00		Total:	420.70m ²
2-4.02	kitchen	9.00		7 Apartments	379.60m ²
2-4.03	Room	24.20		Other room	41.10m ²
2-4.04	Room	12.80			
2-4.05	bathroom	5.00			
2-4.06	balcony	4.40			

Figure 7. Legend of rooms of 2 floor

1.3.5 SERVICES OF BUILDING

Apartment ventilation. Natural. Air is being extracted from kitchens and lavatories and ejected above the roof. The air inflows through the air vents in window frames.

Electricity. The electricity distribution room of the building is equipped with decollator from which a switchboard is connected. Each flat is installed with a power distribution panel with voltage tripping devices. Two-tariff meters.

Water Supply. Cold water supplied from the city water supply network. Hot water prepared centrally in the gas boiler-room. Hot and cold water pipelines are laid to the mains water lines planned for the project. Each apartment is equipped with hot and cold water meters.

Sewerage. Sewer pipes laid to mains sewerage planned in the project.

Fireplaces. The possibility to install a fireplace is planned for every apartment. Chimney flues with clean-out openings are installed. There is a possibility to install an additional fireplace in the mansard or on the terrace.

Fire alarm with smoke detectors and manual fire hazard alarms.

Gas heating, common boiler-room for the building. Two 100kW condensing boilers planned. Individual meters with integrated temperature sensor for each apartment. Heating appliances – pressed steel radiators, convectors.

Cables are laid for installation of telephones, television and the Internet.

2. CONSTRUCTIONAL PART

2.1 DESIGN OF MONOLITHIC ROOF SLAB

In this part there is the calculation of one representative part of the roof slab of the building.

2.1.1 DESIGN DATA

The basic for design slab is presented data in table 2.1.1.

DATUM	VALUE
Characteristic cylinder strength of concrete f_{ck} (MPa)	20
Characteristic strength of s400 steel f_{yk} (MPa)	400
Characteristic density of reinforced concrete (kN/m^3)	25
Partial safety factors: γ_g – permanent load safety factor γ_q – variable load safety factor	1.35 1.3
Exposure class (environmental conditions)	XC1
Minimum cover of longitudinal conditions c_{min} (mm)	35

Table 2.1.1.

2.1.2 DESIGN OF MATERIAL CHARACTERISTICS

1. CONCRETE C20/25

Design concrete compressive strength:

$$f_{cd} = \alpha \cdot \alpha_{cc} \cdot \frac{f_{ck}}{\gamma_c} = 0.9 \cdot 1 \cdot \frac{20}{1.5} = 12 \text{ MPa.}$$

2. STEEL CLASS S400

Design tensile strength $f_{yd} = 400/1.15 = 348$ MPa when the steel is used as longitudinal reinforcement.

2.1.3 CALCULATING LOADS

2.1.3.1 SNOW LOAD

The building is in Vilnius. The region of snow is II, characteristic snow load $s_k = 1.6 \text{ kN/m}^2$.

Snow load:

$$s = \mu_i \cdot C_e \cdot C_t \cdot s_k.$$

Where:

μ_i = roof snow type coefficient;

C_e = coefficient usually is 1;

C_t = thermal coefficient depending on energetic losses through roof or other thermal influence. $C_t = 1$;

s_k = snow coefficient characteristic value.

$$s_k = 1 \cdot 1 \cdot 1 \cdot 1.6 = 1.6 \text{ kN/m}^2.$$

$$s_d = 1.6 \cdot 1.35 = 2.16 \text{ kN/m}^2.$$

2.1.3.2 VARIABLE LOAD

Characteristic variable load on the top of the slab.

$$q_k = 0.4 \text{ kPa};$$

Design variable load on floor:

$$q_d = q_k \cdot \gamma_q = 0.4 \cdot 1.3 = 0.52 \text{ kPa};$$

γ_q = safety coefficient for variable load.

2.1.3.3 PERMANENT LOADS

Characteristic value of permanent distributed load from the slab is determined by the floor cover and the weight of the slab specified in the following table:

Type of structural layer	Layer thickness (m)	Characteristic value of density γ_k (kN/m ³)	Characteristic permanent (self-weight) load (kPa)
Hydroinsulation	0.02	2500	0.490
Thermal insulation	0.03	80	0.023
Thermal insulation	0.22	60	0.129
Vapor barrier	0.005	$9.22 \cdot 10^{-4}$	$4.5 \cdot 10^{-8}$
Concrete C12/16	0.04	2500	0.981
Formation of coat	0.04	350	0.137
Concrete slab	0.22	2500	5.395

Table of materials.

ROOF DETAIL

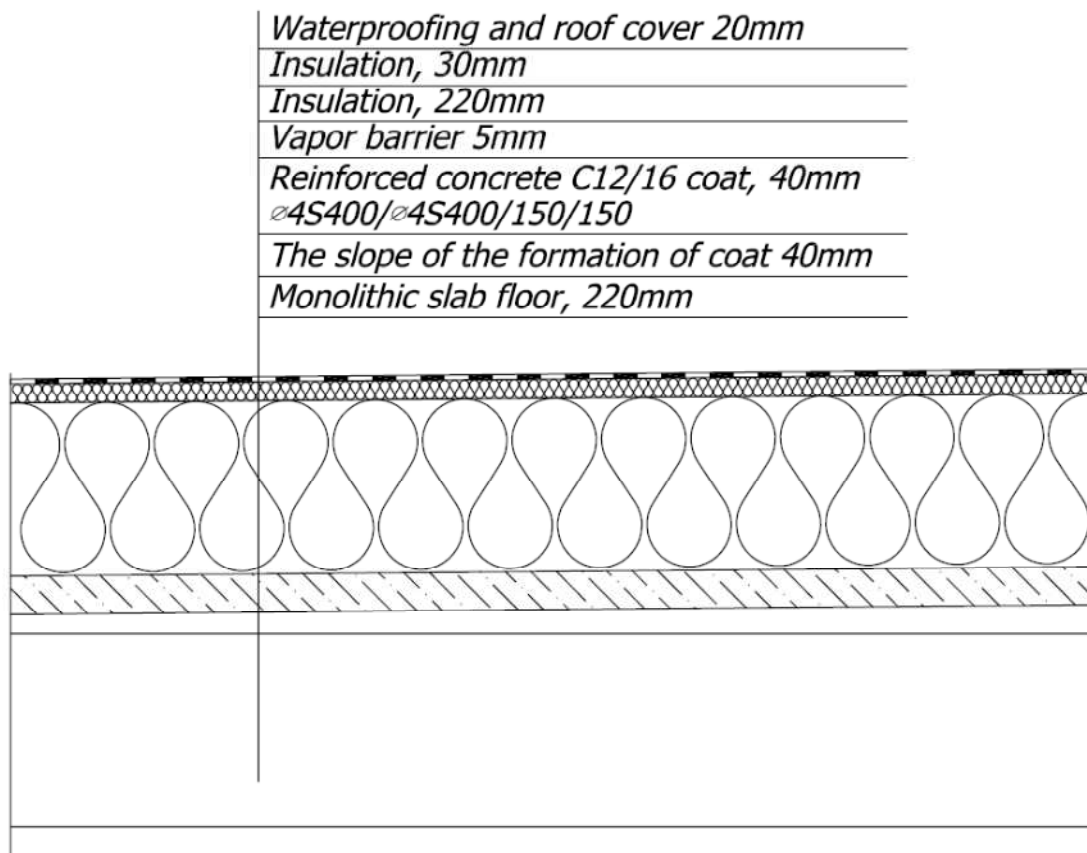

Figure 8. Slab covering of roof.

Characteristic value of floor covering and slab covering:

$$g_{1k} = t_1 \cdot \gamma_1 \cdot g;$$

t_1 = thickness of layer (m);

γ_1 = density of the layer kg/m³;

g = acceleration of free m/s²;

γ_{g1} = partial safety coefficient for self weight = 1.35;

$$g_{1k} = t_1 \cdot \gamma_1 \cdot g = 0.02 \cdot 2500 \cdot 9.81 = 490.5 = 0.490 \text{ kPa};$$

$$g_{2k} = t_2 \cdot \gamma_2 \cdot g = 0.03 \cdot 80 \cdot 9.81 = 23.54 = 0.023 \text{ kPa};$$

$$g_{3k} = t_3 \cdot \gamma_3 \cdot g = 0.22 \cdot 60 \cdot 9.81 = 129.5 = 0.129 \text{ kPa};$$

$$g_{4k} = t_4 \cdot \gamma_4 \cdot g = 0.005 \cdot 9.22 \cdot 10^{-4} \cdot 9.81 = 4.5 \cdot 10^{-5} = 4.5 \cdot 10^{-8} \text{ kPa};$$

$$g_{5k} = t_5 \cdot \gamma_5 \cdot g = 0.04 \cdot 2500 \cdot 9.81 = 981 = 0.981 \text{ kPa};$$

$$g_{6k} = t_6 \cdot \gamma_6 \cdot g = 0.04 \cdot 350 \cdot 9.81 = 137.34 = 0.137 \text{ kPa};$$

$$g_{7k} = t_7 \cdot \gamma_7 \cdot g = 0.22 \cdot 2500 \cdot 9.81 = 5395.5 = 5.395 \text{ kPa}.$$

Design value of loading

$$g_{1d} = g_{1k} \cdot \gamma_{g1} = 0.490 \cdot 1.35 = 0.662 \text{ kPa};$$

$$g_{2d} = g_{2k} \cdot \gamma_{g1} = 0.023 \cdot 1.35 = 0.031 \text{ kPa};$$

$$g_{3d} = g_{3k} \cdot \gamma_{g1} = 0.129 \cdot 1.35 = 0.174 \text{ kPa};$$

$$g_{4d} = g_{4k} \cdot \gamma_{g1} = 4.5 \cdot 10^{-8} \cdot 1.35 = 6.07 \cdot 10^{-8} \text{ kPa};$$

$$g_{5d} = g_{5k} \cdot \gamma_{g1} = 0.981 \cdot 1.35 = 1.324 \text{ kPa};$$

$$g_{6d} = g_{6k} \cdot \gamma_{g1} = 0.137 \cdot 1.35 = 0.185 \text{ kPa};$$

$$g_{7d} = g_{7k} \cdot \gamma_{g1} = 5.395 \cdot 1.35 = 7.283 \text{ kPa}.$$

Design loads

$$g_k = 0.490 + 0.23 + 0.129 + 4.5 \cdot 10^{-8} + 0.981 + 0.137 + 5.395 = \mathbf{7.157 \text{ kPa}};$$

$$g_d = 0.662 + 0.31 + 0.174 + 6.07 \cdot 10^{-8} + 1.324 + 0.185 + 7.283 = \mathbf{9.662 \text{ kPa}}.$$

Total load (permanent + variable)

$$g_k = 7.157 + 0.4 = \mathbf{7.557 \text{ kPa}};$$

$$g_d = 9.662 + 0.52 = \mathbf{10.182 \text{ kPa}}.$$

Total load (permanent + snow)

$$g_k = 7.157 + 1.6 = \mathbf{8.757 \text{ kPa}};$$

$$g_d = 9.662 + 2.16 = \mathbf{11.822 \text{ kPa}}.$$

2.1.3.4 TYPES OF LOADING

Internal forces are calculated depending on types of loading. These types of loadings will be made:

1. $g + q_1$ = self-weight and variable load;
2. $g + s$ = self-weight and snow load.

Maximum moments are taken to have an envelope of the structure.

2.2 STRUCTURAL ANALYSIS OF SLAB

2.2.1 ANALYSIS

The slab was analyzed by hand calculating by frames to take the moments. Firstly is calculated the frame in axis C and, and then, the frame in axis 3 (fig. 9). With this frames we can calculate the reinforcement of that part of the slab. I used as a design load self weight plus snow load because is more restrictive.

2.2.2 RESULTS

Beams that we will study in both directions are presented in fig. 9:

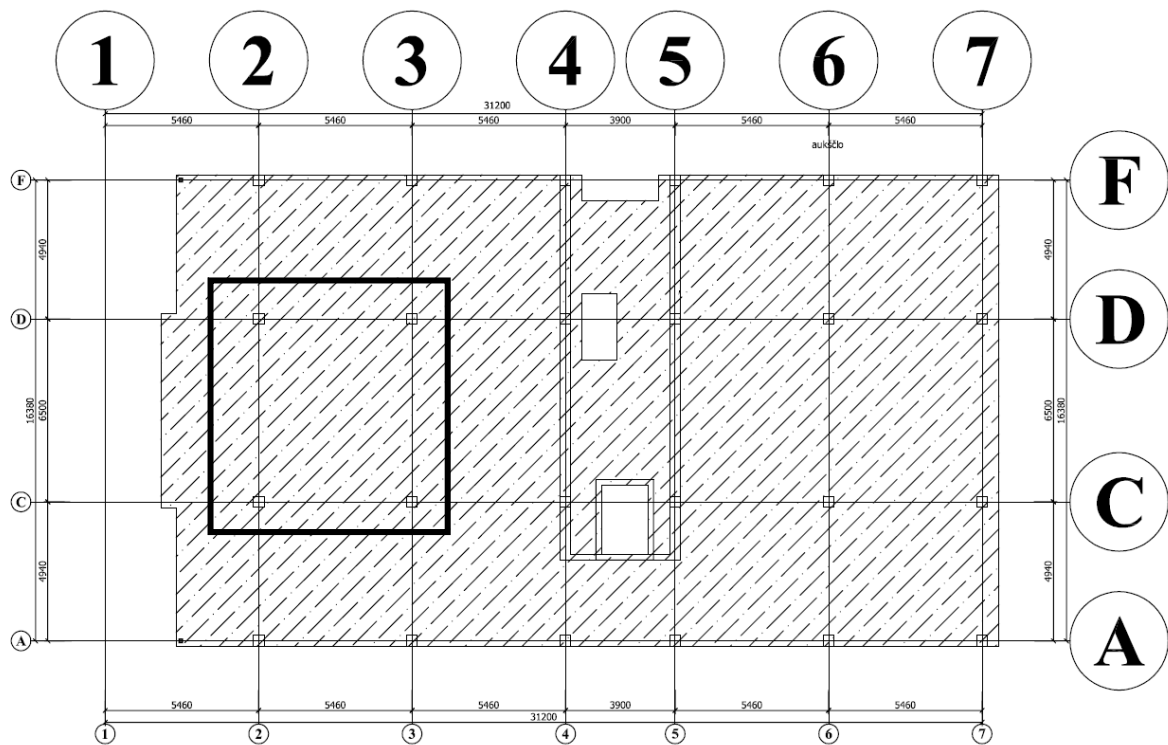

Figure 9. Slab with axes.

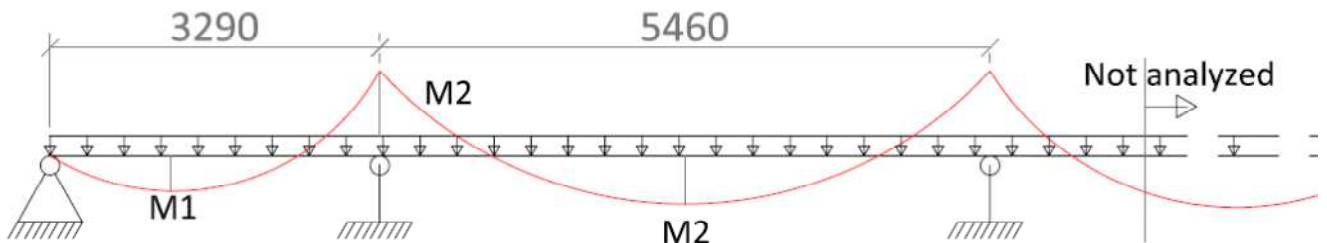

Figure 10. Frame on axis C.

$q_d + s_d = \text{self-weight and snow load} \rightarrow q_d = 9.662 + 2.16 = \mathbf{11.822 \text{ kPa}}$;

$$M_1 = (q_d \cdot b \cdot l^2)/16;$$

$$M_2 = (q_d \cdot b \cdot l^2)/11;$$

Where:

M= moment;

q_d = design load;

b= width of frame;

l= distance between supports;

$$\mathbf{M_1 = (11.82 \cdot 5.7 \cdot 5.4^2)/16 = 122.7 \text{ kNm}}$$

$$\mathbf{M_2 = (11.82 \cdot 5.7 \cdot 5.4^2)/11 = 178 \text{ kNm}}$$

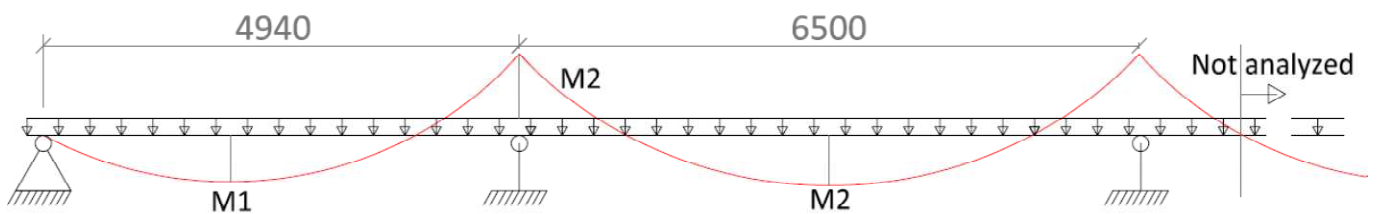

Figure 11. Frame on axis 3.

$$\mathbf{M_1 = (11.82 \cdot 5.46 \cdot 4.94^2)/16 = 98.4 \text{ kNm}}$$

$$\mathbf{M_2 = (11.82 \cdot 5.46 \cdot 6.5^2)/11 = 247.9 \text{ kNm}}$$

2.2.3 DESIGN OF SLAB REINFORCEMENT

The required reinforcement will be provided in a way of saving labour and steel. Steel bars will be tied at the points of intersection using special wire for tying. Tied of steel bars must resist positive and negative bending moments.

Preliminary assumption – to use 12 mm diameter bars for constructing the main reinforcement.

Effects for designing slab are chosen depending on direction and top or bottom reinforcement. Reinforcement will be calculated in two directions. The calculation scheme is presented in fig 12,13.

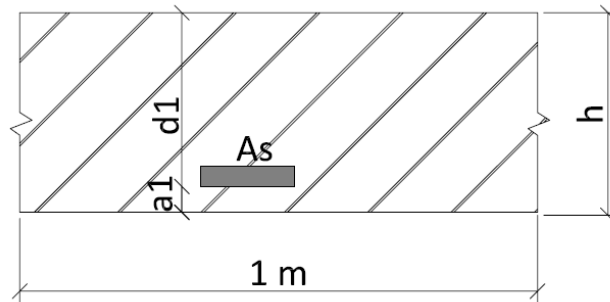

Figure 12. Cross section of slab.

Where:

A_s = steel area;

a_1 = minimum cover = 25 mm;

h = height of slab = 220 mm;

$d_1 = h - a_1 = 220 - 25 = 185$ mm.

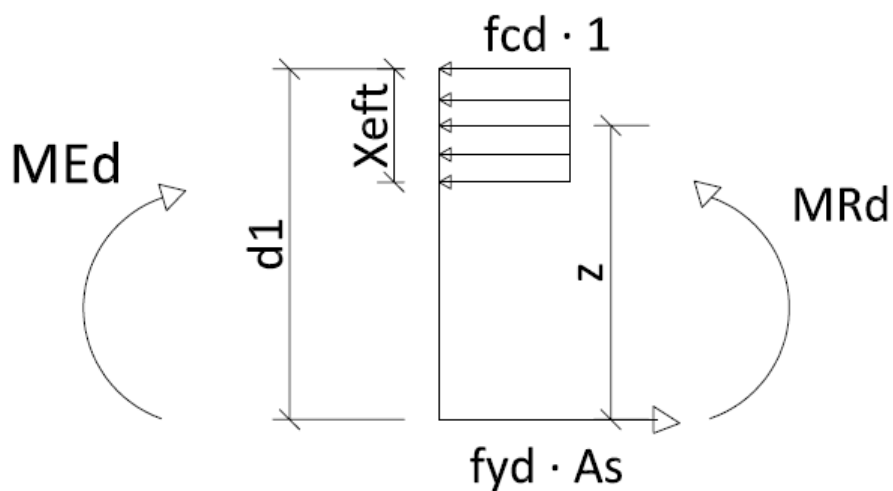

Figure 13. Calculation scheme of RC slab.

$$\Sigma H = 0; \quad f_{yd} \cdot A_s = f_{cd} \cdot 1 \cdot X_{eft};$$

$$X_{eft} = \frac{f_{yd} \cdot A_s}{f_{cd}};$$

$$\Sigma M = 0; \quad M_{Ed} \leq M_{Rd} = f_{cd} \cdot 1 \cdot X_{eft} \cdot (d_1 - (X_{eft}/2)).$$

Resisting moments MRd of one meter width slab is presented in table 2.2.3.

Data:

Concrete C 20/25;

fck= 20 MPa;

fcd = (20/1.5) · 0,9 = 12 MPa;

Steel S400;

fsk = 400 MPa;

fsd = 400/1.15 = 348 MPa.

RESISTING MOMENTS OF 1 M SLAB (Step of bars in 200 mm)			
	1 bar	5 bars	MRd (kNm)
Ø 10 mm	$0.78 \cdot 10^{-4}$	$3.92 \cdot 10^{-4}$	24.32
Ø 12 mm	$1.13 \cdot 10^{-4}$	$5.65 \cdot 10^{-4}$	33.98
Ø 14 mm	$1.54 \cdot 10^{-4}$	$7.69 \cdot 10^{-4}$	46.52
Ø 16 mm	$2.01 \cdot 10^{-4}$	$10.05 \cdot 10^{-4}$	59.52
Ø 18 mm	$2.54 \cdot 10^{-4}$	$12.72 \cdot 10^{-4}$	73.74

Table 2.2.3. Resisting moments of 1 m slab.

Calculation of resisting moment

Ø 10 mm

$$X_{\text{eft}} = \frac{348 \cdot 3.92 \cdot 10^{-4}}{12} = 0.0113 \text{ mm};$$

$$M_{\text{pd}} = 12 \cdot 10^3 \cdot 0.0113 \cdot (0.185 - (0.0113/2)) = 24.32 \text{ kNm}.$$

Ø 12 mm

$$X_{\text{eft}} = \frac{348 \cdot 5.65 \cdot 10^{-4}}{12} = 0.016 \text{ mm};$$

$$M_{\text{pd}} = 12 \cdot 10^3 \cdot 0.016 \cdot (0.185 - (0.016/2)) = 33.98 \text{ kNm}.$$

Ø 14 mm

$$X_{\text{eft}} = \frac{348 \cdot 7.69 \cdot 10^{-4}}{12} = 0.0223 \text{ mm};$$

$$M_{\text{pd}} = 12 \cdot 10^3 \cdot 0.0223 \cdot (0.185 - (0.0223/2)) = 46.52 \text{ kNm}.$$

Ø 16 mm

$$X_{\text{eft}} = \frac{348 \cdot 10.05 \cdot 10^{-4}}{12} = 0.0291 \text{ mm};$$

$$M_{\text{pd}} = 12 \cdot 10^3 \cdot 0.0291 \cdot (0.185 - (0.0291/2)) = 59.52 \text{ kNm}.$$

Ø 18 mm

$$X_{\text{eft}} = \frac{348 \cdot 12.72 \cdot 10^{-4}}{12} = 0.0368 \text{ mm};$$

$$M_{\text{pd}} = 12 \cdot 10^3 \cdot 0.0368 \cdot (0.185 - (0.0368/2)) = 73.74 \text{ kNm}.$$

Calculation of top reinforcement in axis C direction

Distribution of moments in the frame is presented in fig. 13.1.

$M_{\text{Ed}} = 178 \text{ kNm} \Rightarrow$ Acting moment in central part of frame.

$$(178 \cdot 0.75)/(5.7/2) = 46.84 \text{ kNm/m};$$

If main top net is 12/12/200/200 and has a resistance of 33.98 kNm,

$46.84 - 33.98 = 12.86 \text{ kNm}$ that we have to reinforce. We will take Ø 12 mm bars to reinforce the top in C axis direction. Ø 10 mm would be enough but we will take Ø 12 mm to make the built simpler, and we have less possibilities to make less errors.

$M = 178 \text{ kNm} \Rightarrow$ Acting moment in central part of frame.

$$(178 \cdot 0.5)/(5.7/2) = 31.11 \text{ kNm/m};$$

If main top net is 12/12/200/200 and has a resistance of 33.98 kNm,

$31.11 < 33.98$ so it is not necessary to reinforce. The same will be in bottom reinforcement.

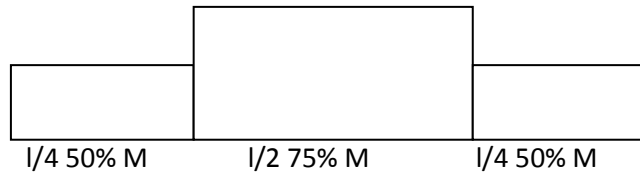

Figure 13.1. Distribution of moments in the frame.

Top reinforcement in axis 3 direction

$M = 247.88 \text{ kNm} \Rightarrow$ Acting moment in central part of frame.

$$(247.88 \cdot 0.75)/(5.4/2) = 68.85 \text{ kNm/m};$$

If main top net is 12/12/200/200 and has a resistance of 33.98 kNm, $68.85 - 33.98 = 34.87 \text{ kNm}$ that we have to reinforce. We will take $\emptyset 14 \text{ mm}$ bars to reinforce the top in C axis direction.

$$(247.88 \cdot 0.5)/(5.4/2) = 45.4 \text{ kNm/m};$$

If main top net is 12/12/200/200 and has a resistance of 33.98 kNm, $45.4 - 33.98 = 11.42 \text{ kNm}$ that we have to reinforce. We will take $\emptyset 10 \text{ mm}$ bars to reinforce the top in C axis direction.

Bottom reinforcement in axis C direction

$M = 178 \text{ kNm} \Rightarrow$ Acting moment in central part of frame.

$$(178 \cdot 0.75)/(5.7/2) = 46.84 \text{ kNm/m};$$

If main top net is 12/12/200/200 and has a resistance of 33.98 kNm, $46.84 - 33.98 = 12.86 \text{ kNm}$ that we have to reinforce. We will take $\emptyset 12 \text{ mm}$ bars to reinforce the top in C axis direction. $\emptyset 10 \text{ mm}$ would be enough but we will take $\emptyset 12 \text{ mm}$ to make the built simpler, and we have less possibilities to make less errors.

Top reinforcement in axis 3 direction

$M = 247.88 \text{ kNm} \Rightarrow$ Acting moment in central part of frame.

$$(247.88 \cdot 0.75)/(5.4/2) = 68.85 \text{ kNm/m};$$

If main top net is 12/12/200/200 and has a resistance of 33.98 kNm, $68.85 - 33.98 = 34.87 \text{ kNm}$ that we have to reinforce. We will take $\emptyset 14 \text{ mm}$ bars to reinforce the top in C axis direction.

$$(247.88 \cdot 0.5)/(5.4/2) = 45.4 \text{ kNm/m};$$

If main top net is 12/12/200/200 and has a resistance of 33.98 kNm, $45.4 - 33.98 = 11.42 \text{ kNm}$ that we have to reinforce. We will take $\emptyset 10 \text{ mm}$ bars to reinforce the top in C axis direction.

Disposition of this bars is presented in drawing CONSTRUCTIONAL PART, number 2.

3. TECHNOLOGICAL CARDS

3.1 TECHNOLOGICAL CARD OF GYPSUM PLASTERBOARD PARTITIONS

3.1.1 GENERAL DESCRIPTION

We are going to study the plasterboards of second floor. There are 70.7 m² of normal plasterboard and 25.93 m² of waterproof plasterboard. Waterproof plasterboard will be in wet zones such as bathrooms.

Plasterboard partitions are composed of a metal frame and gypsum board screwed to each side. The metal frame is attached to the original construction and constitutes a support for mounting plates.

For special cases you can use a double structure with adequate separation. In the gap between the plates can be placed a fiberglass or rock lada for greater thermal and acoustic insulation and for fire protection. Furthermore, in the gap can perform the necessary facilities (electric, sanitary etc.).

Structure

- Rail 48 mm. Firmly attached to the floor and roof.
- Upright vertical 48 mm. Introduced into the lower and upper channel separation of 400 or 600 mm. As needed.
- Start and end uprights fixed to the structure of encounter.
- Other free intermediate uprights, without setting the upper and lower canals.
- In double grid walls when these are separated more than 5 mm., fix with gusset plates 300 mm.
- To stitch height uprights, you can use one of the following three methods:
 - a) A piece of a canal to the studs.
 - b) A piece of upright in a drawer two arriving
 - c) Insert a stud into another (as drawer)

Materials needed:

Plasterboard

Canals

Uprights

Acoustic band

Screw TN

fixings uprights

Acoustic

Grab Pasta Knauf Perlfix

Pasta EJS Meeting

Meeting Tape

Personnel needed:

1 Official of construction

Regular worker

3.1.2 CONSTRUCTION PROCESS

1. Stakeout

2. Installation of the structure:

If possible, the lower rails are installed on the flooring completed or on your seat base and the higher will be placed by usually upon completion of the roof plate or forged under once plaster.

The seat rails are held by a tight band. With this simple operation will achieve a significant gain in thermo-acoustic insulation.

Once reframed the wall in floor and ceiling shall be set "Rails", which can be anchored to the support (screed or forged) by means of expansion bolts or rivets, spaced a maximum of 800 mm.

Then you will have the "pillars" supporting elements vertical, which is accommodated between the wings of the channels using a rotary motion. The wheelbase is stud a maximum of 600 mm and provided with multiple of the width of the plate.

The sums to be screwed to the rails except for the boot in transit openings, windows and other very singular so required.

3. Transit openings:

When the partition coincides with a hole (either door or window), the modulation of the studs will not be lost, but is maintained, placing the stiles and rails as well as a rim.

4. Installing the plate:

Plates shall have a height equal to the span between floor and ceiling, least 1 cm. Be supported on the supporting structure so that the upper edge of the plate is "butt" with the top floor, plastering whether you are or not. In this way the clearance of 1cm. remain in the bottom and will be covered subsequently by baseboard.

Once the plate in position on one side of the structure, proceed to screw (first face), while meeting the distance between bolts does not exceed 250 mm. In case of partitions laminates (layers), the first plate is fixed to the structure maximum equidistant screws 700mm.

The joints of the plates of a wall face of ever coincide with the other. In the laminates of two or more boards, the boards are alternate. The side plates will butt or up to 3mm.

5. Placement of isolation and passage facilities:

The electrical and plumbing facilities go within the saving camera studs through the holes provided in them. The studs are supplied with pre-drilling side to facilitate the transition of facilities (pipes and electricity plumbing). The electrical conduit boxes have to be fully subject to the board, for the purpose recommended installing pin boxes.

6. Installing the plate (second side)

7. Completion of the septum. Joint treatment:

Continuity and finish of the walls is done by treating the joints between plates and liquid gasket tape or tape and paste finish. Also apply paste to the head of the screws. Subsequently, if necessary, be held sanding boards to achieve desired flatness before painting. It is important to coordinate the work done so that the joint treatment is appropriate as soon as possible to your decor. The surface of the plates, exposed for some time to sunlight, direct or indirect, can discolor the plate further hampering painted. In the case of waterproof plasterboard, we should protect with ceramic tiles or another material, and we should attach it with glue cement.

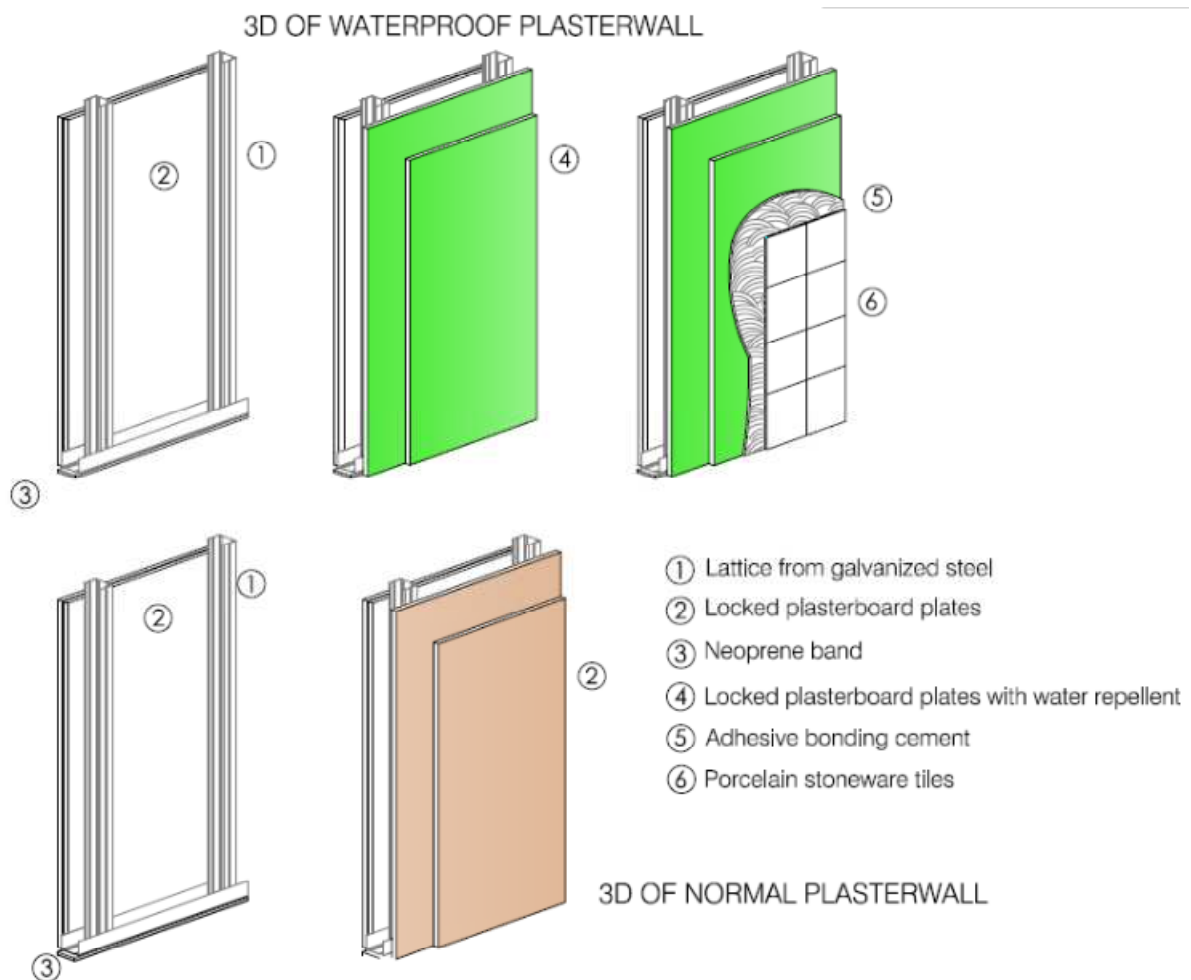

Figure 14. 3D of process

3.1.3 INSTALLATION SEQUENCE

Here we can see the sequence of works from 1 to 10. The entry of material is marked with the lifting system. Red walls are waterproof plasterboard and black walls are normal plasterboard. Figure 15. Red color is waterproof plasterboard, and black is normal.

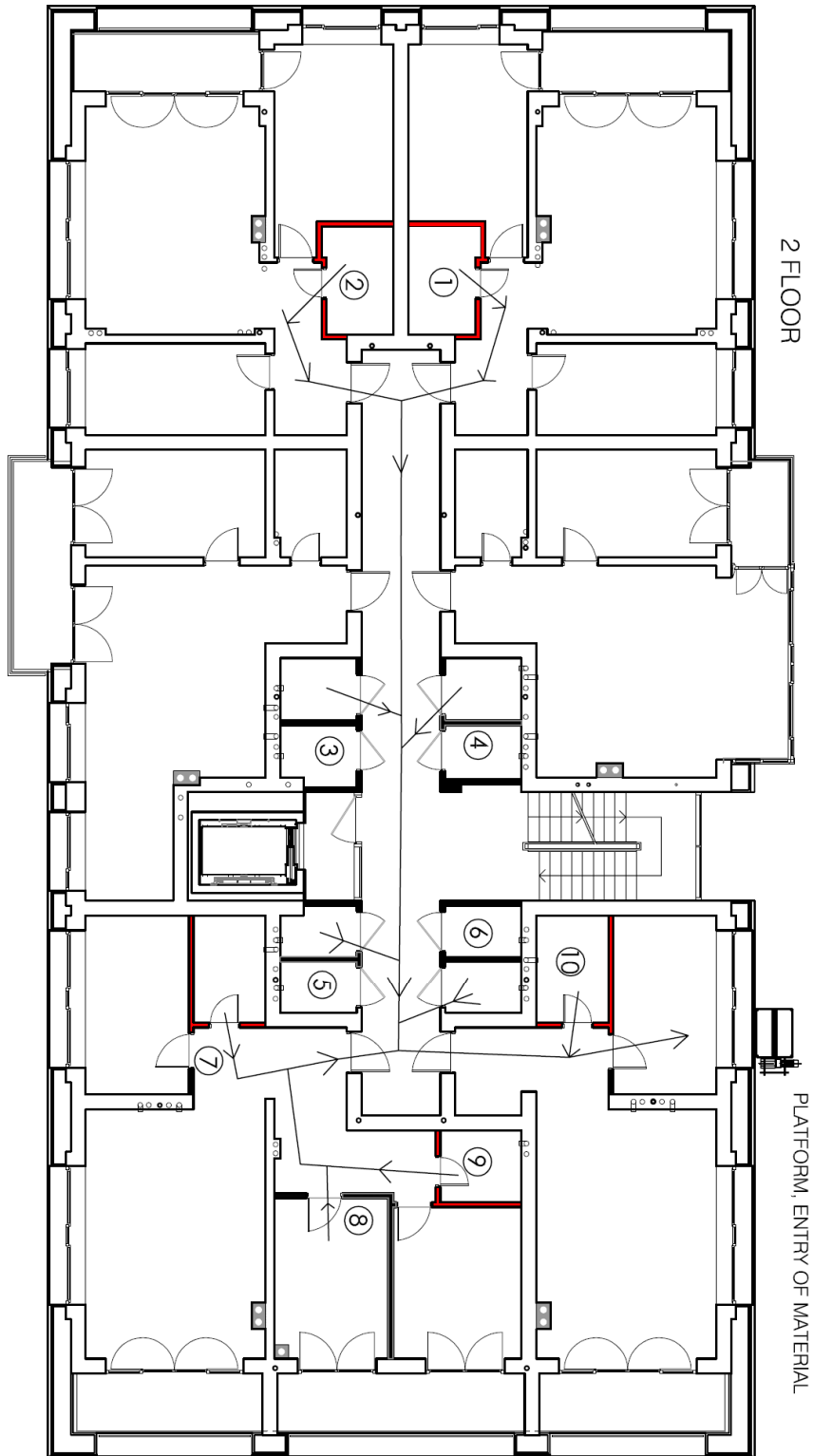

Figure15.Sequence

3.1.4 ORGANIZATION OF WORKS

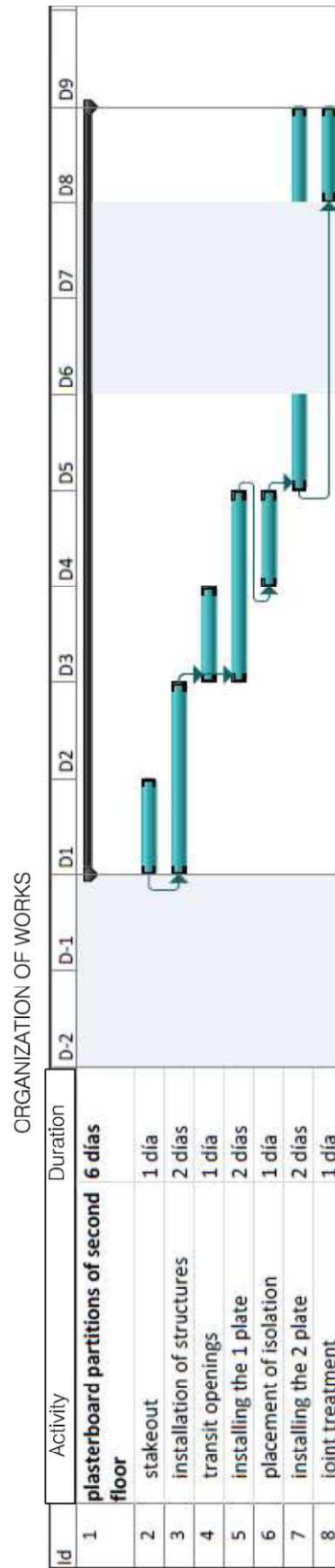

Figure 16. Organization

3.1.5 HUMAN SAFETY

The works are not qualified as dangerous, the workers only have to wear work clothes, gloves, work boots, and helmet. If they have to cut the plasterboard or another materials, they must wear protective glasses. And they must to check if all electrical parts are in good conditions and grounded. The place of work must be clean.

3.1.6 MECHANICS, MATERIALS AND TOOLS

NAME	UNIT	QUANTITY
MACHINES		
drill screw	u	1
MATERIALS		
plasterboard normal 12.5 mm	m2	304.01
waterproof plasterboard 12.5 mm	m2	111.5
canal rail 30x48x0,6 mm	m	56.56
upright 46x36x0,6 mm	m	233.31
screw 25 mm	u	2121
screw 45 mm	u	1414
micro perforated paper band	m	190.89
jointing paste	kg	71
TOOLS		
hammer	u	1
level	u	1
spatula for joints	u	1

3.1.7 QUALITY CONTROL

The most important control is to check that the stakeout is correct before starting the installation of structures. We must check that the dimensions are right. After that, we should check that the materials are of good quality and if is in perfect conditions. Finally we will check that the finishes are correct.

Tolerances on the execution and completion of systems Gypsum Laminated

a) Setting out: Errors may not be greater than + 20 mm. not cumulative.

b) Appearance: The surface finish should allow the application of decorative coatings, as shown in section finishes.

c) local flatness: A rule of 200 mm., Applied over the facing surface in all directions and especially along the joints, can not detect the zone between outgoing and the incoming one dimension more than 1 mm., or abrupt changes of the plane.

d) General Flatness: A rule of 2,000 mm., Applied on the surface of the facing in either direction, cannot detect between the zone more outgoing and incoming an upper bound to 5 mm.

e) Crash: The maximum allowable slump in a partition or cladding to a height of 3,000 mm. will not exceed 5 mm. in units with different heights, this should be discussed with the manufacturer's Technical Services.

f) Horizontality: Standard deviation of the plane of reference is less than 3 per thousand, but not to exceed 2 cm.

3.1.8 TECHNICAL ECONOMICS INDICATORS

NORMAL PLASTERBOARD

Quantity of works: 70.7 m²

Installation costs: 3501.48 € = 12080.06 LTL

Duration of works: 3.53 days/floor ≈ 4 days/floor

Wage of 1official of construction: 3.53 x 8 h = 28.24 h -- 28.24 h x 21.8 € = 615.63 € or 2123.92 LTL

Wage of peon of construction: 28.24h x 20.83 € = 588.23 € or 2029.39 LTL

WATERPROOF PLASTERBOARD

Quantity of works: 25.93 m²

Installation costs: 1.521.83 € or 5250.31 LTL

Duration of works: 1.29 days/floor ≈ 2 days/floor

Wage of 1official of construction: 1.29 x 8h = 10.32 h -- 10.32 h x 21.8 € = 224.97 € or 776.14 LTL

Wage of peon of construction: 10.32 h x 20.83 € = 214.96 € or 741.63 LTL

3.1.9 SOME DETAILS

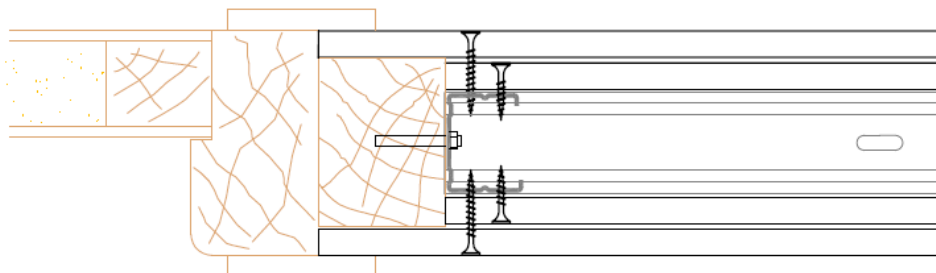

Figure 17. Detail of plasterboard with door

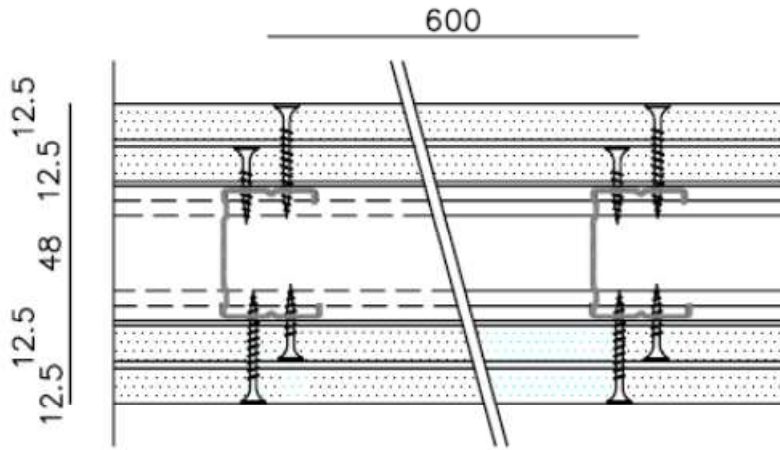

Figure 18. Detail of plasterboard with metal frames

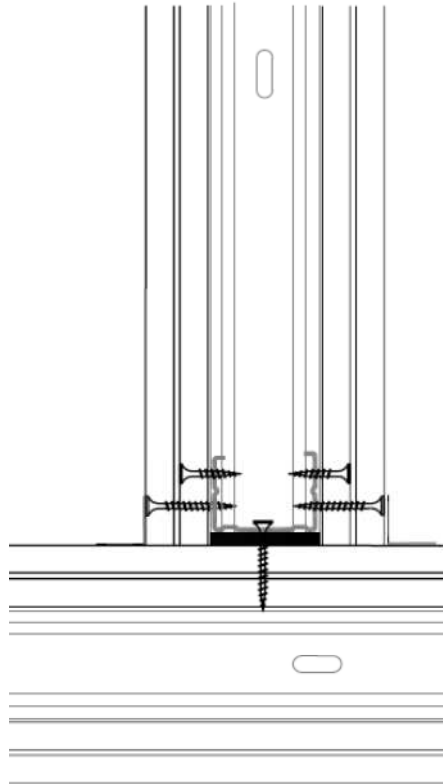

Figure 19. Detail of encounter of plasterboard

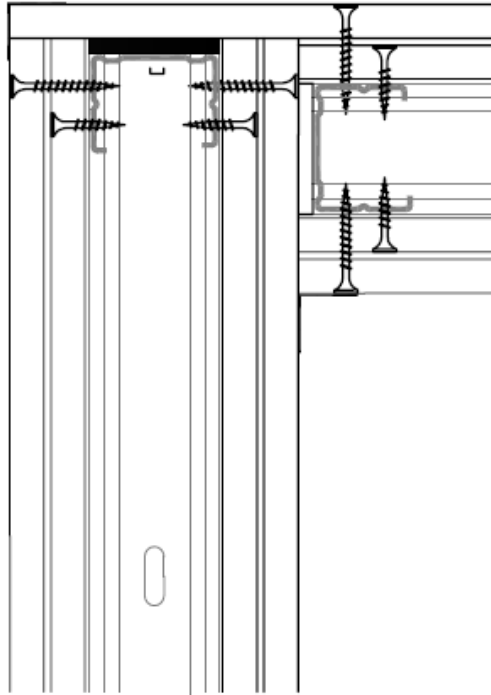

Figure 20. Another kind of encounter



Figure 21. Placement of plasterboard

3.1.10 BUDGET

BUDGET OF NORMAL PLASTERBOARD

Partition consists of a 46 mm galvanized structure, with canals such as horizontal element and uprights as a vertical axis with a separation of 40 cm and double plasterboard 12.5 mm thick, ready to paint, even stakeout court preparation and placement of the plates and support structure, level and plumb, formation of sub-frames, angles and step execution of facilities, joint finishing, share of losses, breaks, fixing and cleaning accessories. m2

		price	amount
1º official of construction	0,4 h	21,8	8,72
regular peon of construction	0,4 h	20,83	8,33
plasterboard normal 12.5 mm	4,3 m2	4,47	19,22
canal rail 30x48x0,6 mm	0,8 m	1,63	1,3
upright 46x36x0,6 mm	3,3 m	2,08	6,86
screw 25 mm	30 u	0,02	0,6
screw 45 mm	20 u	0,03	0,6
microperforated paper band	2,7 m	0,06	0,16
jointing paste	1 kg	3,04	3,04
additional direct costs	0,02%	48,55	0,97
			49,52
measurements	70,7 m2	3.501,48 €	12080,06 LTL

BUDGET OF WATERPROOF PLASTERBOARD

Partition consists of a 46 mm galvanized structure, with canals such as horizontal element and uprights as a vertical axis with a separation of 40 cm and double plasterboard 12.5 mm thick with waterproof mass of plaster and surfaces, ready to paint, even stakeout court preparation and placement of the plates and support structure, level and plumb, formation of sub-frames, angles and step execution of facilities, joint finishing, share of losses, breaks, fixing and cleaning accessories. m2

		price	amount	
1 ^o official of construction	0,4 h	21,8	8,72	
regular peon of construction	0,4 h	20,83	8,33	
waterproof plasterboard 12.5 mm	4,3 m2	6,56	28,21	
canal rail 30x48x0,6 mm	0,8 m	1,63	1,3	
upright 46x36x0,6 mm	3,3 m	2,08	6,86	
screw 25 mm	30 u	0,02	0,6	
screw 45 mm	20 u	0,03	0,6	
microperforated paper band	2,7 m	0,06	0,16	
jointing paste	1 kg	3,04	3,04	
additional direct costs	0,02%	48,55	0,97	
			58,69	
measurements	25,93 m2		1.521,83 €	5250,31 LTL

3.2 TECHNOLOGICAL CARD OF VENTILATED FAÇADE (CERAMIC)

3.2.1 GENERAL DESCRIPTION

We study the ventilated façade with ceramic finish. The surface covered with this kind of façade is 290.46 m².

The ventilated facade is a design element consisting of two sheets, one outdoor and one indoor, which contain between them an air vented instructing the seal and protect from direct sunlight.

The inner sheet

The inner sheet is part of the building may be secured to the carrier or enclosure. This should ensure thermal insulation, will mean the closure of the interior space and form the outer blade holder. Our inner sheet is built by blocks of 38 cm of thickness, and has thermal insulation of mineral wool in his exterior part.

The outer leaf

The outer leaf should be understood as an overall envelope of the building, lying on it as an absolutely independent. Its function is to form the tube and set the image outside the building.

The outer sheet may be formed of any material that resists weathering. The materials that may be employed are diverse face brick, bricks with continuous coating, cladding stone, metal panels, panels of high density, etc..

Both layers should be as independent as possible, although logically it should be anchored by the foreign keys to the interior, or elements of the structure to be stable.

An important objective of the commissioning work will ensure the free movement of the outer sheet. Their high exposure to weather and solar radiation, its thinness and how to be supported, requiring high differential freedom of movement of each piece and set against the media.

The outer sheet can have varying thicknesses depending on the material used to resolve, with the only limitation established its own stability and union of parts. The most common case is that of a half-foot wall of brick or stucco exterior or without a stone veneer. In any case, the restraint system should be suitable to anchor the material chosen.

Our outer sheet is built with metal canals and the finish is with ceramic.

The air

The chamber evacuates water which may penetrate through the outer sheet, so that in no case can reach the inner sheet. This ensures the seal and the inner sheet is always dry. This requires that the wires forming the clamps binding and are the only contact between the two sheets, having a central fold act of eaves or a small inclination to the plane of the facade. In addition, heat that accumulates the convection chamber is evacuated, so that the inner element is perfectly protected from direct solar inputs.

3.2.2 CONSTRUCTION PROCESS

In the case of ventilated façade, the enclosure is built from the inside out, allowing the work to be performed simultaneously inside (finishes, flooring, partition walls, plaster ...) and the outer face thereof.

1. Inner leaf

First is the inside of the front sheet lightweight masonry blocks. In order to ensure a seal and allowing a suitable thermal and acoustic insulation, it is desirable to plaster or revoque with waterproof mortar the wall surface of lightweight masonry facing the camera, at least outwardly grouting vertical joints.

After mortar in outer part, we will place the thermal insulation in panel form.

At the same time are placed keys the outer sheet. The keys to fixing the exterior sheet in any case should be in sight.

If necessary insulation materials are added in the areas that may appear thermal bridges.

Lifting the inner leaf is useful to place simultaneously rims in the holes. This ensures the correct setting out of the facade and the seal is provided here.

2. Outer leaf

Finally the outer sheet is executed (mortar avoiding falling within the camera if it is a leaf of brick), leaving the holes needed to ensure ventilation thereof.

Keep in mind the high exposure of the outer sheet, which may suffer changes in temperature of 50 °C and 80 °C, depending on their color. Therefore, this sheet should not present any rigid connection with the building and be constructed with joints necessary to ensure free deformation. Each building and each situation will require a precise study of the joints, although it is recommended that the distance between them never exceeds 15 meters. The thickness of these joints will be between 10 and 20 mm.

The maximum height of the outer sheet will be limited by its own stability.

The blade should be supported in some way at the edges of the floors of each one, two or three plants. Each section of the outer sheet should be independent of the lower and higher. There will be a horizontal joint that will prevent any deformation of the support he can put you in contact with the bottom sheet. It is therefore advisable to first run the outer sheet of the top floor of the building and go down to the lowest floor. There is the possibility of constructing the outer leaf continuous throughout the height of the building, using keys that slide along guides integral with the structure, being necessary in this case reinforce the facade in bed joint reinforcement.

2.1. Keys and other unions

The stability of the outer sheet is achieved by using keys that anchor to the inner leaf bearing or structural elements. The fastening system will only allow movement of the outer sheet in its own plane, avoiding the approach or separation of the inner sheet.

The arrangement and mechanical strength of the attachment elements depend on various factors: the design of the key itself, the material, its placement, exposure of the building, the chamber depth, etc. It will require the manufacturers of these products the technical indications necessary for proper placing. The position of the keys and the amount will depend directly on their function, they must be correctly specified in the project.

The distance between keys should not exceed 40 cm vertically and 90 horizontally, being suitable alternate available. The recommended amount of 35 to 50 cameras mm²/m² to less than 10 cm.

They can also distinguish two types of bindings: those that are distributed throughout the inner sheet fixing and exclusively in the heads of the floor. In the latter case the calculation should ensure the strength of the outer pane to the horizontal.

When the outer sheet extends to the top of several plants, the weight of higher plants compensates for the horizontal tensile stresses that can result in lower plants. Only the top floor, the security of this coverage is a bit low and should increase the number of keys.

The impossibility of subsequent maintenance of protection of these anchors and exposure to moisture are essential to make stainless steel.

2.2. The support of the outer pane in a building height.

The greatest difficulty in the design of a ventilated façade exterior sheet heavy, raises the same support when building height exceeds reasonable limits as thin foil. For buildings over three stories is common the use of support in each slab, or every two or three floors.

To minimize the thermal bridge that is supported by the outer ply in the slab, you can use any of the following systems:

With metallic support, anchoring the edge of the floor supports for the outer pane. These supports are specially designed to support the bricks, stone veneers and the various boards that can be employed. The most common is the use of a fixed wing angle with the edge of the slab and the other flying to receive the load of the outer pane. The angle should be stainless steel, setting simple and robust and should also resolve the inaccuracies of the floor construction. The metal support should not reach the outside of the leaf, but stay about 2 cm to allow the rubber seal of the board.

Between the profile and the material forming the outer skin of the facade have an insulating material to prevent thermal bridge at the edge of the slab. It is also very advisable to have a bib waters leading to the outside at the height of each support, protecting the screws and the profile (in brick walls, evacuation is usually done through the holes of the wounds, freeing one in three bricks in the row of support).

Modify the edge of the slab with a small flight that allows the full support of the outer pane.

Use special ceramic, thick and high mechanical resistance, placed cantilevered over the edge of the slab and anchored thereto by stainless steel fasteners.

3.2.3 CONSTRUCTION SEQUENCE



Figure 22. Sequence

In the picture we can see with grey color the parts of the façade that we are studying. We will close the 16 part the last because there, is programmed as entry of material for interior partitions, flooring, services... etc.

3.2.4 ORGANIZATION OF WORKS

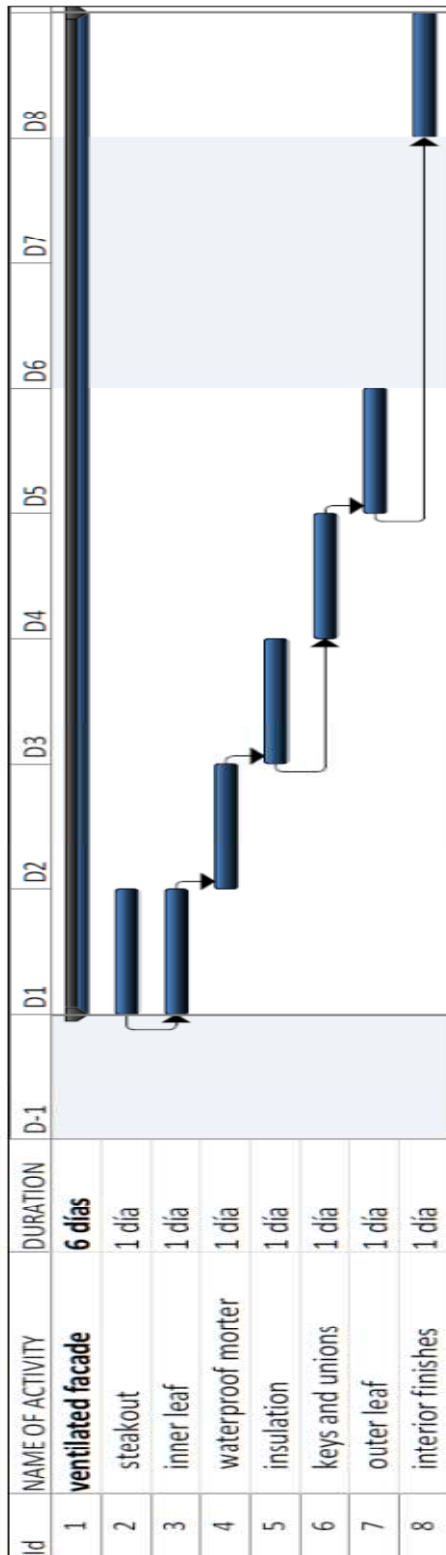

Figure 23. Organization of works

This work schedule is for each little part of construction. There are 16 sequences, and this is for each part. There are parts that will have 5 days.

3.2.5 HUMAN SAFETY

This work is classified as hazardous because the job is in high. the best solution is to work with a scaffold equipped with skirting board and double-rail as a collective protection. As a individual protection, workers should use harness, work clothes, gloves, protective boots and helmet. the worker has to know how lifting weight in the correct way. If the job is cutting some material, worker must to use protective glasses. The electrical devices must be in perfect conditions and grounded.

3.2.6 MACHINES, MATERIALS AND TOOLS

NAME	UNIT	QUANTITY
MACHINES		
drill screw	u	1
radial saw	u	1
MATERIALS		
Lightweight blocks 30x19x19	u	4940
Panel of polyurethane	m2	304.98
Panel adhesive	l	29.05
Cement mortar M 2,5	m3	13.94
Waterproofing cement mortar	m3	2.9
Cement mortar M 5	m3	4.35
Plaster paste	m3	4.35
Ceramic tiling	m2	290.46
Plastic coating	m2	290.46
TOOLS		
trowel to flat	u	1
level	u	1
trowel	u	1
carrycot	u	1
paint roller	u	1

3.2.7 QUALITY CONTROL

We must to check before built that the materials correspond to those specified in the control plan or, case, the specification the project.

They have the documentation required.

They are characterized by properties required.

They have been tested, where established in the program Control.

During the execution we will check:

- State of the support, the collapse or deviation from flatness should be able to be offset by the set of joints in brackets.
- Stakeout and position of the brackets and modulation according to the project specification.
- Check that the brackets are well calculated, which are placed according to project.
- Check distance between brackets, flatness, alignment (tolerance $\pm 1 \text{ mm / m}$) and horizontal joint ($> 2 \text{ mm per m}$).
- Check that the insulation covers the entire outer face of the support wall and the resistant structure of the building and check its thickness.
- Check that the width of the horizontal and vertical joints between tiles or plates, meet the tolerance established in the project.
- Check that the building expansion joints coincide with a vertical board cladding system by a double bracket.
- Check the execution in accordance with construction details of the project or system (leaks, waste water, etc.)

Upon completion of the ventilated facade they will be visited thereof, in order to verify that specifications are met dimensional established in the project.

3.2.8 SOME DETAILS

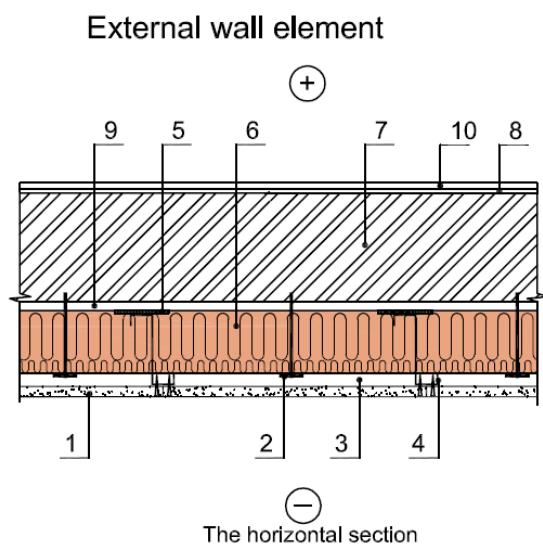

- 1 - Finish (plaster, or ceramic. Plate)
- 2 - Pin
- 3 - Air space, 20 ... 30 mm
- 4 - Metal Profile
- 5 - Interim
- 6 - Thermal insulation, 180 mm
- 7 - Lightweight masonry blocks, 380 mm
- 8 - Interior plaster
- 9 - Waterproof mortar
- 10 - Interior revoque

Figure 24. Facade

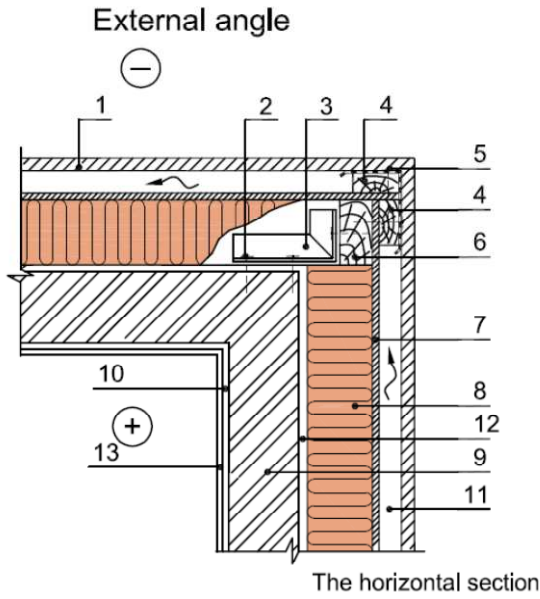

- 1 - Finish (plaster, or ceramic. Plate)
- 2 - Fixing dowels, screws
- 3 - Beams mounting angles
- 4 - Additional beams
- 5 - Nails
- 6 - The main beams
- 7 - Wind isolation (comes with thermal ins.)
- 8 - Thermal insulation, 180 mm
- 9 - Lightweight masonry blocks, 380 mm
- 10 - Interior revoque
- 11- Air space, 20 ... 30 mm
- 12 - Waterproof mortar
- 13- Interior plaster

Figure 26. External angle

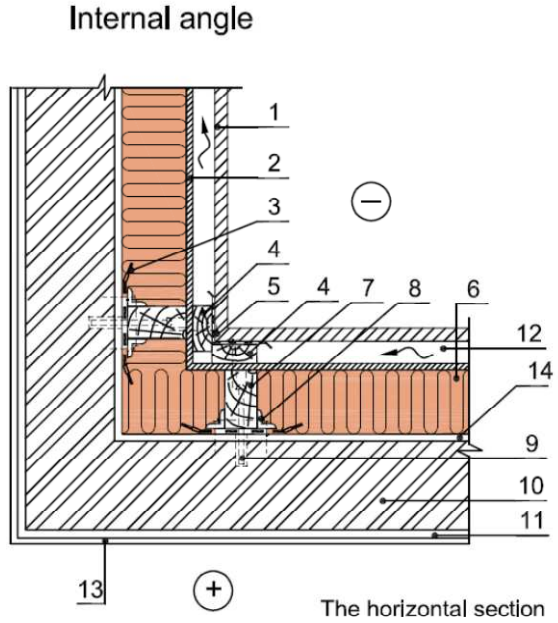

- 1 - Finish (plaster, or ceramic. Plate)
- 2 - Wind insulation (comes with thermal ins.)
- 3 - Flashing tape
- 4 - Additional beams
- 5 - Nails
- 6 - Thermal insulation, 180 mm
- 7 - The main beams
- 8 - Beams mounting angles
- 9 - Masonry nails
- 10 - Lightweight masonry blocks, 380 mm
- 11- Interior plaster
- 12- Air space, 20 ... 30 mm
- 13- Interior revoque
- 14 - Waterproof mortar

Figure 25. Internal angle

3D OF VENTILATED FACADE

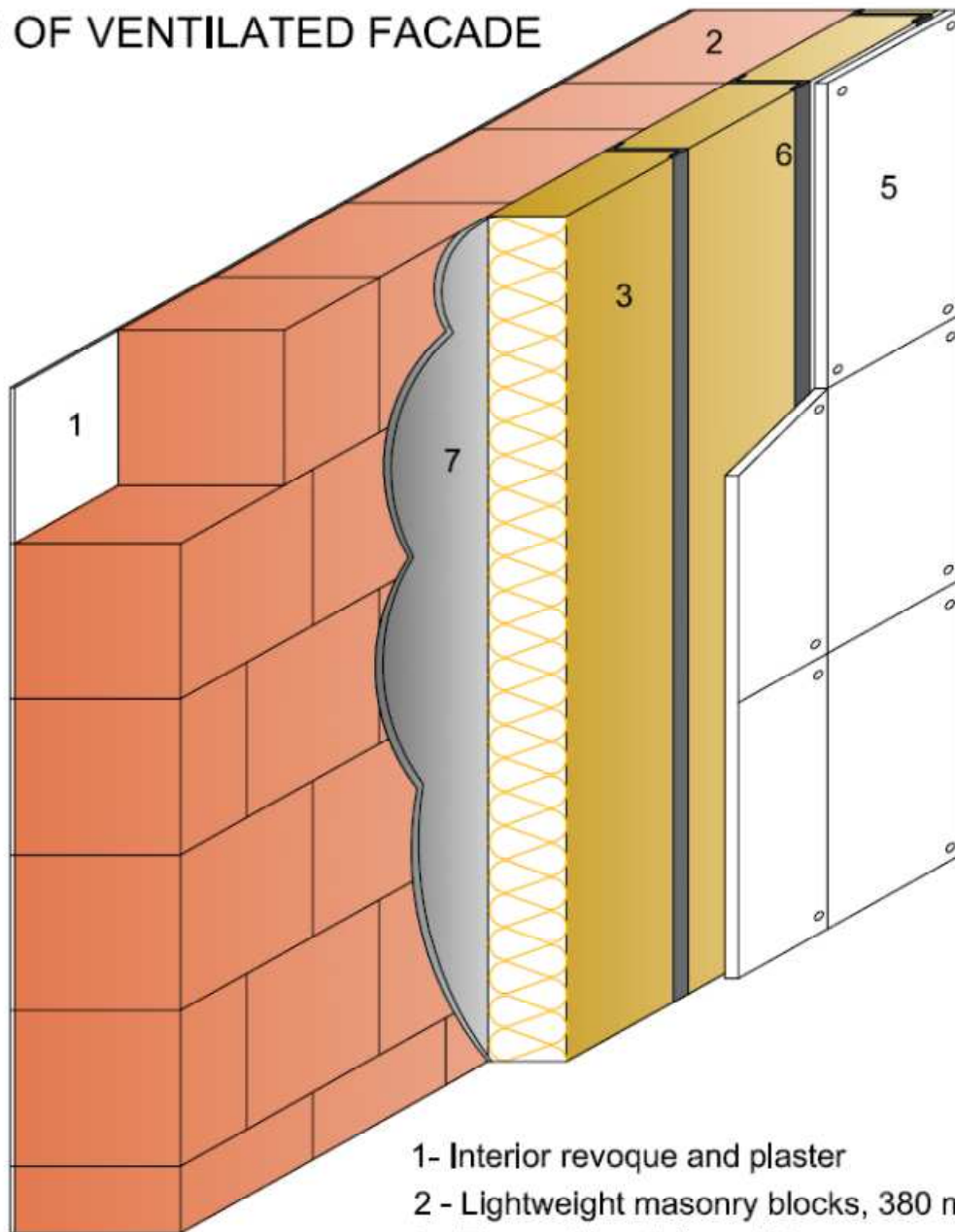

- 1- Interior revoque and plaster
- 2 - Lightweight masonry blocks, 380 mm
- 3 - Thermal insulation, 180 mm
- 4 - Air space, 20 ... 30 mm
- 5 - Finish (ceramic)
- 6 - Metal Profiler
- 7 - Waterproof mortar

Figure 26. 3D of facade layers

3.2.9 BUDGET

Main sheet enclosure composed of 380 mm thick, made of lightweight blocks with plaster mortar waterproofing of 1.5 cm thickness by its outer side, no thermal insulation based hydrophilic polyurethane sheets of 180 mm thickness, coated on the outside with ceramic tiling placed with mechanical fasteners corrosion resistant, with ventilated air chamber through the joints of the cladding and the interior plaster trim and finished with thin plastic coating, including formation of lintels and jambs, execution meetings, special items and received structural work, considering a 3% loss and a 20% shrinkage of mortar.

		price	amount
1 ^o official of construction	2,5 h	21,8	54,5
Regular peon of construction	2,5 h	21,2	53
Lightweight blocks 30x19x19	17 u	0,6	10,2
Panel of polyurethane	1,050 m ²	42,93	45,08
Panel adhesive	0,10 l	11,46	1,15
Cement mortar M 2,5	0,048 m ³	69,36	3,33
Waterproofing cement mortar	0,01 m ³	144,46	1,44
Cement mortar M 5	0,015 m ³	102,68	1,54
Plaster paste	0,015 m ³	149,44	2,24
Complementary direct costs	0,03	89,61	2,69
Ceramic tiling	1 m ²	99,98	99,98
Plastic coating	1 m ²	4,67	4,67
			279,82
measurements	290,46 m ²		81.276,51 € 280403,98 LTL

3.2.10 TECHNICAL ECONOMICS INDICATORS

Quantity of works: 290.46 m²

Installation costs: 81.276,51 € = 280403,98 LTL

Duration of works: 90.76 days ≈ 91 days

Wage of 1 official of construction: 90.76 x 8 h = 726.15 h -- x 21.8 € = 15830.07 € or 54613.74 LTL

Wage of peon of construction: 90.76 x 8 h = 726.15 h -- x 21.2 € = 15394.38 € or 53110.61 LTL

4. ORGANIZATION PART

4.1 MASTERPLAN

4.1.1 DESCRIPTION

In the plan of building lot is intended:

- The main machines working places and moving tracks
- Storages and storing sites positions
- Temporary electricity, water-supplying, sewerage and fireplug, positions
- Safety and dangerous zones
- Temporary access roads and passages
- Temporary buildings positions

The plan of building lot is preparing before starting constructional works. The lot is on planning, trees, which are impeding, are cutting of, the soil is pushed aside and stored. All the site preparation has to be made according to construction organizing project. The building lot is surrounding by fence. The working zone of crane and dangerous zones are marked. On the preparation stage, it is necessary to do these works:

- To prepare temporary building for workers
- To cut trees which are in the building zone
- To make a entrance to work place
- To prepare storage sites

All temporary buildings will be supplied by electricity. The building site will be supplied by electricity from the transformer substation, where is the main electricity distributional and accounting lock and cable.

The bathroom temporary building will be supplied by water, and will need sanitary installation.

4.1.2 SELECTION OF TOWER CRANE

Calculation of technological parameters of tower crane.

First of all the following parameters of installing building have to be known:

1. The dimensions of building and location (underground and over-ground parts).
2. The weights, dimensions and location of installing constructions.
3. The work conditions (the peculiarities of building site, soil characteristics, the peculiarities of underground structures).

First of all, you must check if crane technical characteristics match the inequalities:

$$Q_k > Q_R.$$

$$H_k > H_R.$$

$$L_k > L_R$$

Here:

Q_k – the ascension power of selected crane, t

Q_R – the required ascension power, t

L_k - the reach of selected crane boom, m

L_R - the required reach of crane boom, m

H_k - the lifting height of selected crane hook, m

H_R – the required lifting height of hook, m

The technological parameters of crane are calculating according to the building characteristics. The required crane is selecting according to the tables of technical characteristics of cranes.

Tower crane selection when the underground and over-ground works are fulfilling like in the future building.

First of all, using the next, formula the required height of hook lifting is determining:

$$H_R = h_1 + h_2 + h_3 + h_4 = 13.50 + 2 + 0.5 + 3.5 = 19.50 \text{ m.}$$

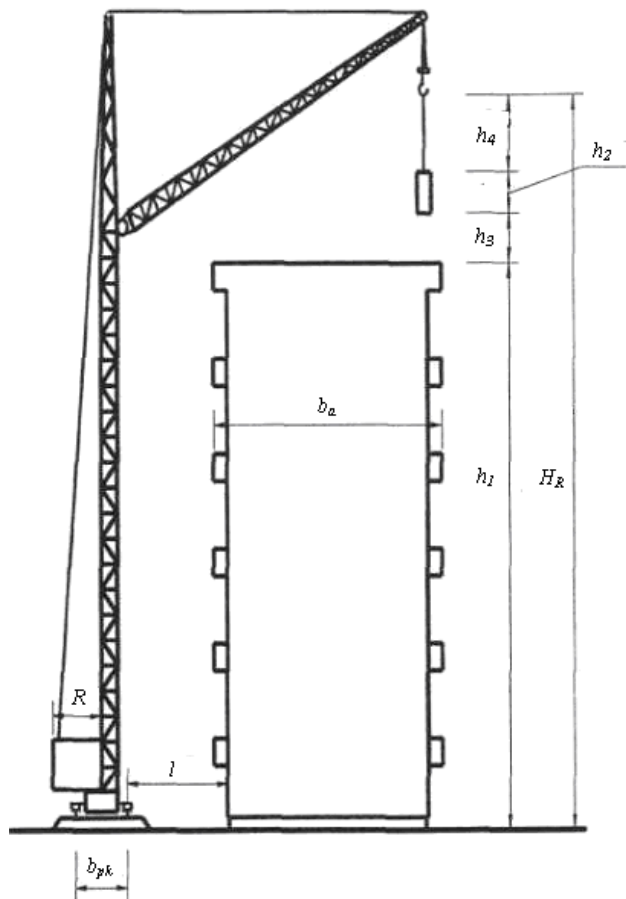

Figure 27. Characters of formulas

Here (figure 27) :

h1 – the height of abutment (support), on which the installing element is bracing, which is calculating from the under-crane track or the bottom of support, m

h2 – the height of installing element, m

h3 - free interval between abutment (support) and installing element (0.5 – 1 m)

h4 – the height of hitching (trailing) equipment (strops) above the installing element, m.

Then the ascension power of crane is calculating using the next formula:

$$QR = P + Pstr = 3 + 0.15 = 3.15 \text{ t}$$

Here:

P - the weight of heaviest lifting construction, t

Pstr- the weight of hitching (trailing) equipment (strops), t

If crane will install only the over-ground construction such as our crane, the reach of boom will be determined according to formula:

$$LR = l + ba + \left(\frac{bpk}{2}\right)$$

Here:

l - the distance from the marginal support of under-crane track to the building, m

ba - the width of over-ground part of building together with balconies and bow-windows, m

bpk - the width of under-crane track or supports, m

And:

$$l = \left(R - \frac{bpk}{2}\right) + (0.7 - 1)$$

here R – the radius of crane platform turn.

We know l = 2.5 m, so:

$$LR = 1 + 35.6 + (3.8/2) = 38.5 \text{ m}$$

When the values of LR, HR and QR are calculated, the crane could be selected using the diagrams of the tower crane. The diagrams show, that the selected crane 50 EC-B5 LIEBHERR, match all requirements.

$$\begin{aligned} Q_k &= 5 \text{ t} > QR = 3.15 \text{ t} \\ H_k &= 42,1 \text{ m} > HR = 19.50 \text{ m} \\ L_k &= 45.4 \text{ m} > LR = 38.5 \text{ m} \end{aligned}$$

You can see the crane information in the next website:

[http://www.liebherr.com/CC/en-GB/region-\(europe\)/products_cc.wfw/id-12481-0/measure-metric](http://www.liebherr.com/CC/en-GB/region-(europe)/products_cc.wfw/id-12481-0/measure-metric)

DETAIL OF BASE OF CRANE

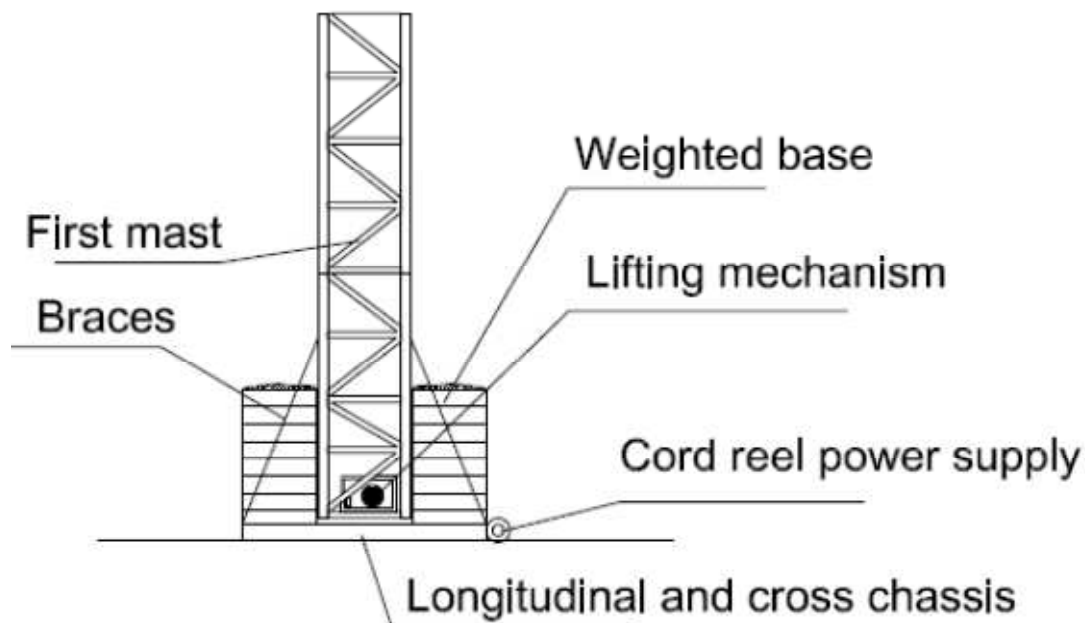

Figure 28. detail base of crane

4.1.3 SETTING OF DANGEROUS ZONE

During the installment works in some parts of the construction site, in bars, workplaces, and crossings the dangerous areas are appearing. In construction such areas are known as dangerous zones. In the beginning of construction works and during construction, dangerous zones in which constantly arise or may arise risk factors should be determined. The dangerous zones are dividing into two groups:

1. Dangerous zones, in which dangerous and or hazardous factors constantly affect the processes.
2. Dangerous zones, in which dangerous factors could appear.

1. Dangerous zones, in which dangerous and or hazardous factors constantly affect the processes, are:

- Near the electrical equipment with non-insulated parts electric current (flow) (Table 1);
- Fenceless zones at a height when height difference is 1.3 m and the higher;
- Places where hazardous wastes and or the concentration of harmful substances in workplace air may exceed the limit values.

Voltage, kW	Distances, limiting the dangerous zone from the fenceless uninsulated parts of the electrical equipment or from the vertical plane, which is the nearest power line wire, with a projection on the land, m
< 1	1,5
1 ÷ 20	2,0
35 ÷ 110	4,0
150 ÷ 220	5,0
330	6,0
500 ÷ 750	9,0
800 (current)	9,0

Table 1. The boundaries of dangerous zones were the influence of electric current (flow) could appear.

The boundaries (limits) of dangerous zones, were appear the risk factors of harmful substances exceeding should be determined by measurements.

2. Dangerous zones, in which dangerous factors could appear, are:

- near buildings under construction and assembling (or dismantling) building structures or equipment;
- places over which the structures or equipment installation (or dismantling) works are executing;
- places over which a loads are lifting and transporting by cranes;
- places where the machinery, their parts or work equipment are moving.

This group of dangerous zones is determining by evaluating the possible fall distance of lifted element, which depends on the lifting height (Table 2).

The lifting height of element, m	The minimum possible fall distance of lifted element, m	
	When the element lifted by crane	When the thing (item) falls from the structure (building)
< 10	4	3,5
< 20	7	5
< 70	10	7
< 120	15	10
< 200	20	15
< 300	25	20
< 450	30	25

Table2. Determination of the fall distance of lifted element.

Dangerous zones, close to the moving parts of machinery and equipment is 5 m from them, if there is no more strict or additional requirements in instructions of machinery and equipment manufacturers.

Dangerous zones, which are constantly affected by danger and (or) nuisances, must be enclosed by fences that stops the workers with no right of access to such areas.

Dangerous and hazardous areas must be fenced and marked by signal warning signs or otherwise clearly marked. The dangerous operations must be authorized.

The determination of crane dangerous zones

The limits of dangerous zones areas, where there is transfer of elements is performing by cranes, are determining by calculation the sum (the total distance) of horizontal projection of lifted element, the maximum dimension (length) of biggest element and it's possible fall distance.

The limits of dangerous zones near structures are determining by summarizing the maximum dimension (length) of biggest installed element and it's possible fall distance.

The limits of dangerous zones for construction planning (general plan) are recommended to determine by following:

$$R_{dangerous} = P + l + r$$

Here (figure 29):

r - possible fall distance of the biggest lifted element, m. (see Table 2)

P – the reach of crane boom (R_{reach}) and a half of lifted element length (or maximum dimension), measuring in meters and calculating according to formula:

$$P = R_{reach} + \frac{l}{2}$$

Here:

l – the biggest lifted element, m

So:

$$P = 33 + 3/2 = 34.5 \text{ m}$$

$$R = 34.5 + 3 + 5.5 = 43 \text{ m}$$

The figure below shows how to determine the dangerous zone for crane, as well as graphically visible dimensions needed to summarize.

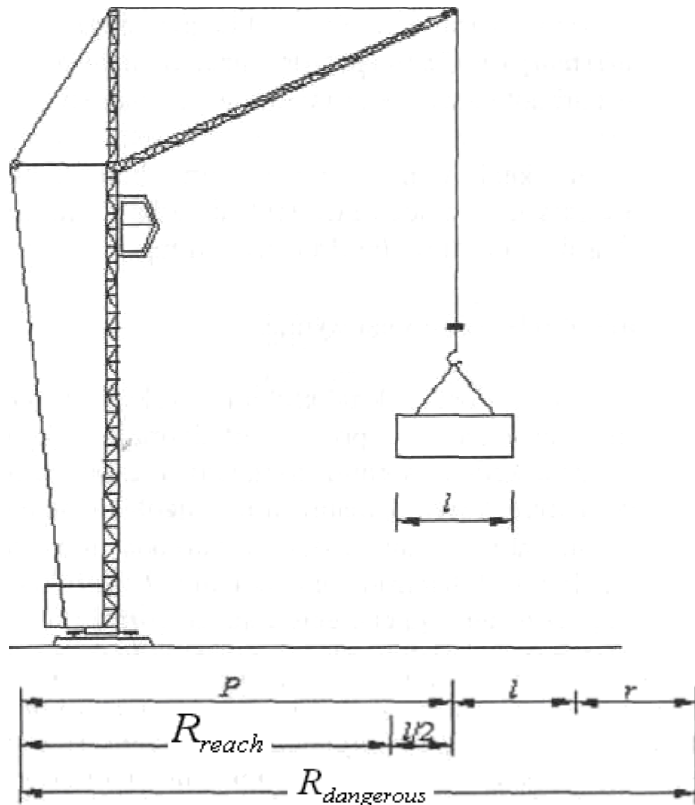

Figure 29. The determination of crane dangerous zones

Will be considered the next risks:

- Presence of obstacles.
- Areas of way.
- Jobs in proximity to high voltage power lines.

The prevention measures, for the first four are specifications established on the basis of the following legal texts:

-Royal Decree 836/2003 of 27 June, approving a new Technical Instruction "MIEAEM2" Regulations Lifting and handling equipment, referring to tower cranes for construction or other applications.

-Royal Decree 1215/1997 of 18 July laying down minimum safety and health for use by workers in teams.

It should be borne in mind also that through Article 5 of the ITC-MIEAEM2, binding is established in the UNE 58-101 - 92, Part 2: Lifting heavy equipment. Terms of strength and safety removable crane works. Conditions of installation and use with what we have for each of the assumptions made as follows:

Presence of obstacles

In paragraph 7.3 of the UNE 58-101-92, states: "The vertical clearance between the pen and the last area of movement of personnel shall be 3 m minimum. If the load or empty hook passes within 3 m of the area, will be necessarily placed on it enough to prevent the indicators of his approach.

This means that when the crane weathervane turn must respect the next distances:

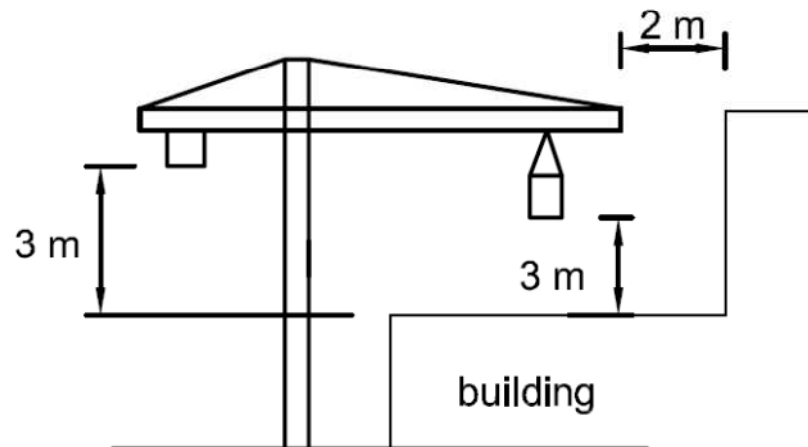

Figure 30. Horizontal and vertical obstacles

As you can see, we are not inclined to use signaling and also taking into account the flexibility of these structures, we have considered a minimum distance between the tip of the arrow and the nearest obstacle of 2 m Walkways in paragraph 4.1 of the UNE 58-101 92 states: "The minimum clearance for the passage of personnel, among the most prominent parts of the crane and any obstacle is 0.60 m wide and 2.50 m high. In case of failure application of this condition will prohibit the access of staff to this area dangerous". Figure 30, 31

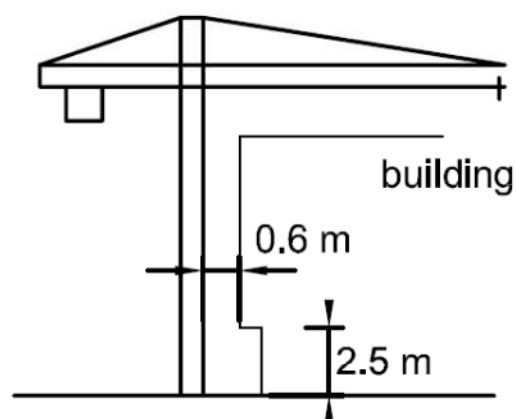

Figure 31. Safety distances

Obstacles in proximity of high voltage power are lines referenced in paragraph 4.1 of the UNE 58-101-92, states: "At no time any part of the crane and its suspended loads, can enter contact with power lines. If these lines are high voltage power should exist between these lines and these items a safe space of 5 m, as minimum, measured in horizontal projection". Figure 32

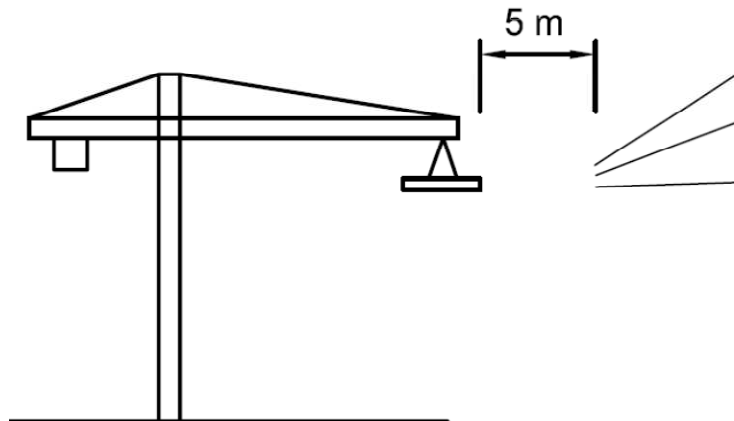

Figure 32. Distance with electrical services

We can see below the section of the building with the position of the crane, and below of this picture is the position in aerial view.

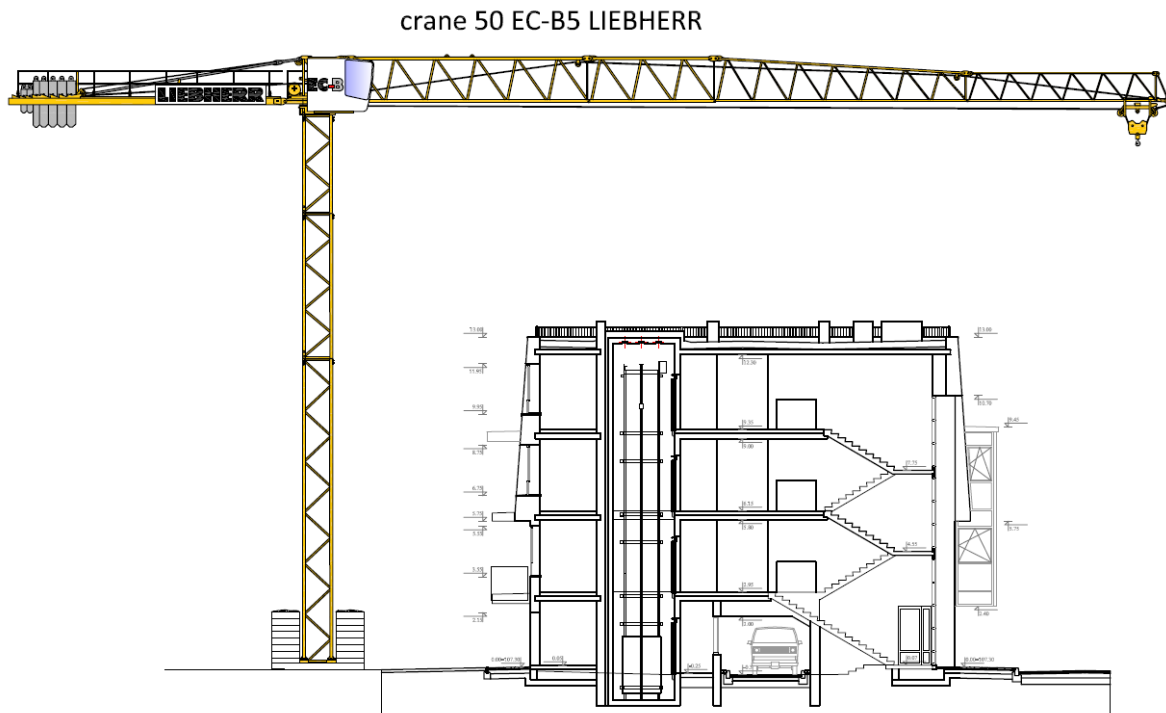

Figure 33. Position of crane with cross section

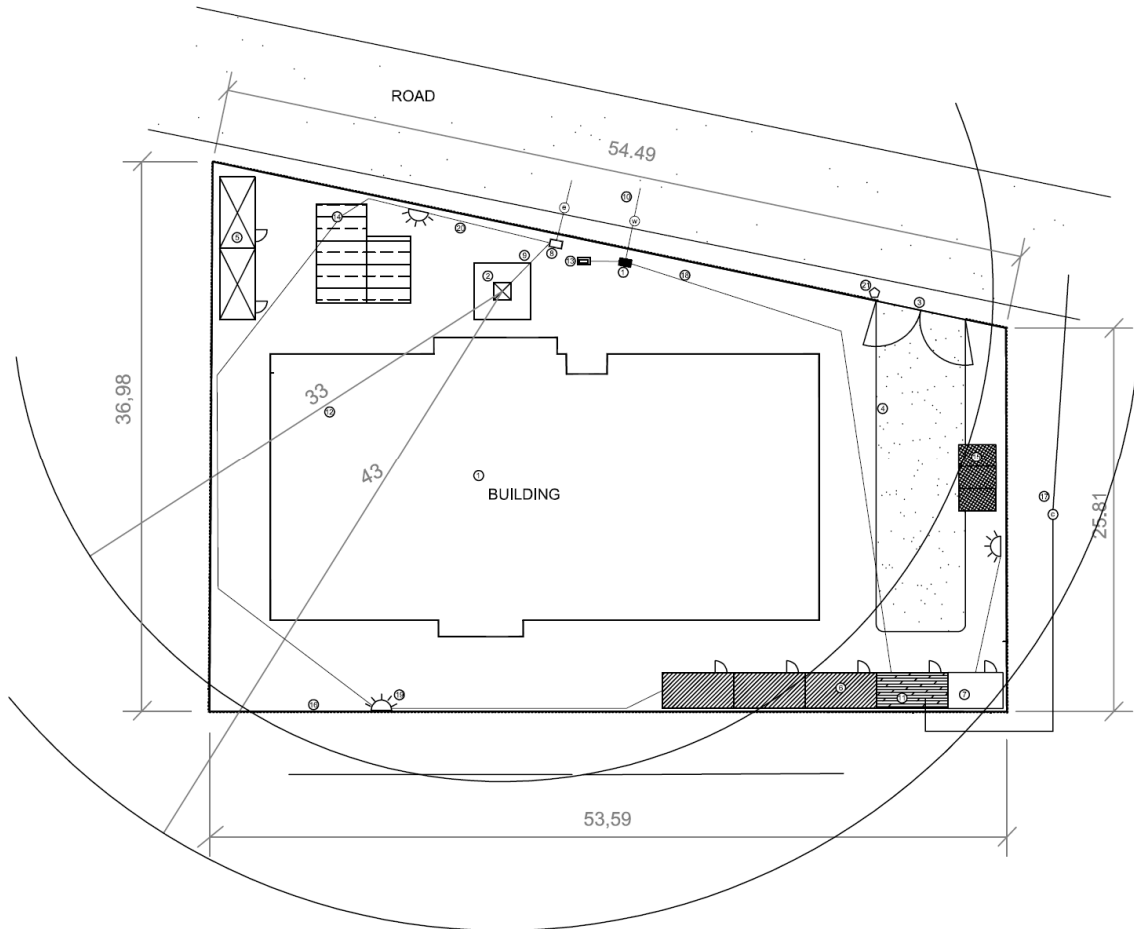

Figure 34. position and radio of crane

4.1.4 TEMPORARY ROAD

Temporary roads in the building places are used to bring construction materials , etc. Temporary roads are built combining with existing roads to reach warehouses, work places, machines and etc. outside the building place. In our building site is 6 meters of width and 21.7 meters of length.

4.1.5 TEMPORARY STORAGE BUILGINGS AND SITES

We have in the construction site two storage buildings of (4.80 m x 2.40 m), and an uncovered area of 35.7 m². That places are enough to keep all storages and stockpiles of materials, little machinery, etc.

4.1.6 TEMPORARY BUILDINGS

To satisfy our needs we will put in our construction site three workers buildings of (4.80 x 2.40 x 2.60) m, one management office of (3.70 x 2.40 x 2.60) m, one temporary toilet and shower building of (4.80 x 2.40 x 2.60) m.

Knowing the number of workers that are working simultaneously we can calculate the number of temporary buildings.

We will can leave these buildings when the interior of our building will be habitable. We put one or more areas for functions performed by temporary buildings.

ROOMS AND TOILETS NEEDS

Before starting the work 2 m² / Worker with minimum height of 2.30 m.

Banks, lockers, racks and so on.

Toilets and showers 1/10 Workers.

Mirrors 1/25 Workers Length = safety clothing.

Toilet 1.00 x 1.20 m and H = 2.30 m 1/25 men workers and 1/15 women workers separated.

You can rent a room in other building.

Drain.

Information: <http://www.consmetal.es/casetas-de-obra.html>

4.1.7 TEMPORARY BUILDINGS

We will need a temporary electricity supply installation with counter to electric company. Mostly of works will need electricity to be done. For example tower crane needs electricity continuously.

Our installation will be of an individual 4x16 mm² derivation.

Justification of individual 4x16 mm² derivation

$$P=3 \cdot u \cdot i \cdot \cos f$$

Where:

P = Power in W

U = Voltage in volts for three-phase system as is in the case 400V

I = intensity in A.

cos f = power factor (in Spain is considered 0,9)

I max adm = maximum admissible intensity in A.

I= 40 A

I= 63 A (intensity of the protection element) (the switch of the box)

I max adm= 80 A according to rebt itc-bt 19 tabla 1 (Spanish rules REBT 02)

So:

$I_{ab} < I_n < I_{max adm}$ (justification that satisfies the individual derivation overload).

TABLE OF CONTROL AND PROTECTION TEMPORARY INSTALLATION WORKS

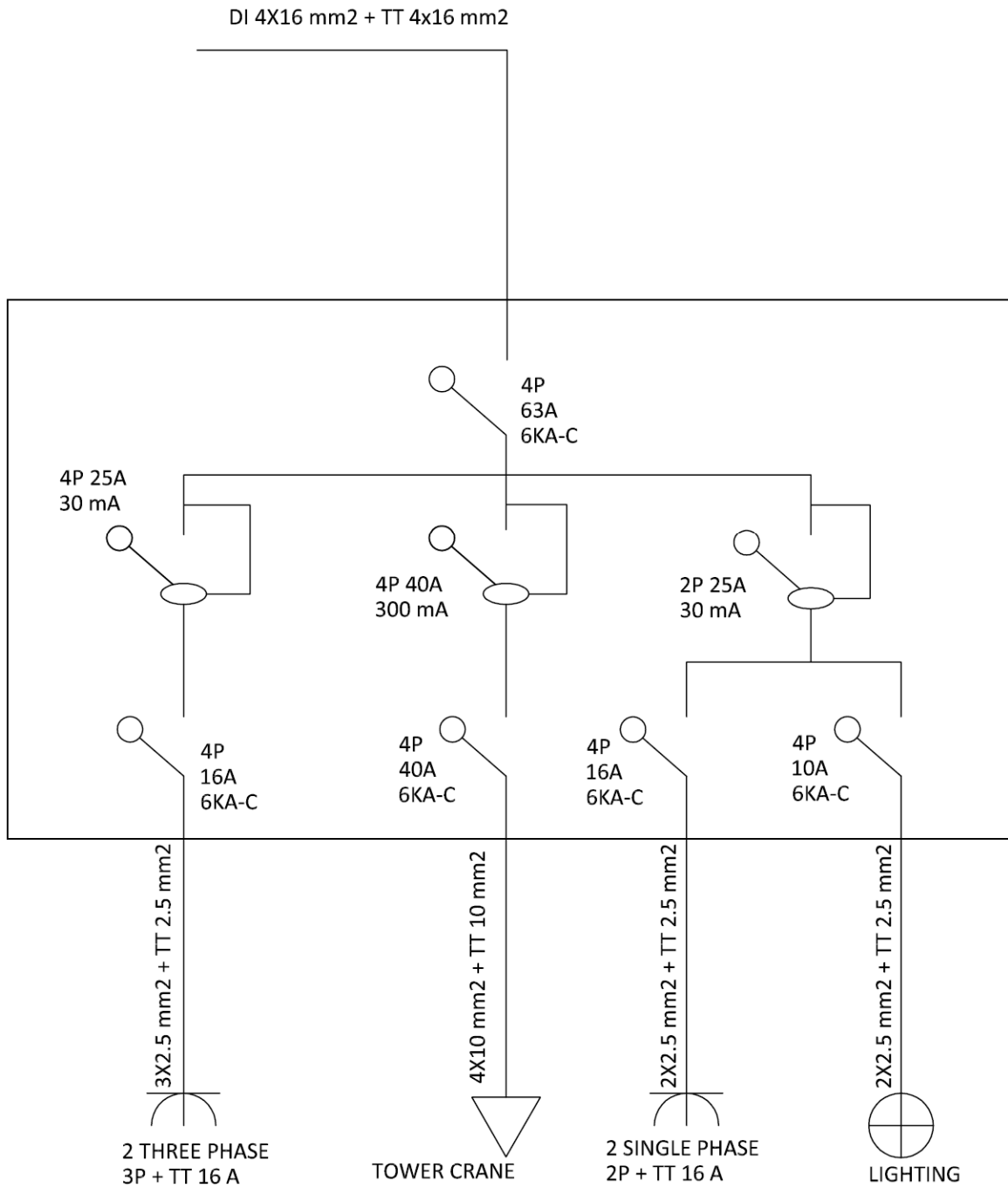

Figure 35. Individual 4x16 mm2 derivation

4.1.8 CONSTRUCTION SITE LIGHTING

To calculate the number of luminaries necessary for the correct illumination of the work, is used the following formula:

$$N = \frac{E \times A}{\phi_n \times F_u \times F_m}$$

Where:

N: Number of luminaries required.

E: Average luminance in lux.

ϕ_n : Flow Rate of the lamp in lumens.

F_u : Factor of use.

F_m : maintenance factor.

A: Local Area

The surface of the work area is 1678 m², to be illuminated with an average illumination of 15 lux, with 1x150 W metal halide lamps, which produce a luminous flux of 10,000 lumens per lamp. Will be used a normal maintenance factor 0.95.

Data from the lighting area are:

Length: 54.00 m.

Width: 37.00 m.

Height: 4.50 m

Index: $K = (l \times b) / h(l+b) = 1678 / 4.5 (37 + 54) = 6$

With this index, and media with colors for floors and ceiling, and clear to the walls, is a factor in initial use in direct lighting luminarie 1.

$$N = \frac{15 \times 1678}{10000 \times 1 \times 0.95} = 2.6 \approx 3 \text{ lamp}$$

Thus the number of lamps required for proper lighting of the premises is:

By calculation we have obtained, the need to place a minimum of 3 lamps.

4.1.9 TEMPORARY WATER SUPPLY

Of course will be needed a temporary water supply for our works. Will be installed a general accountant in the building fence connected to the water supply rush of the city placed close to the road.

The future temporary water supply line will require an accountant, stopcock general, pipe tube 32mm in diameter (is the standard diameter in Spain), wash step and tap.

All the things mentioned before, are shown below.

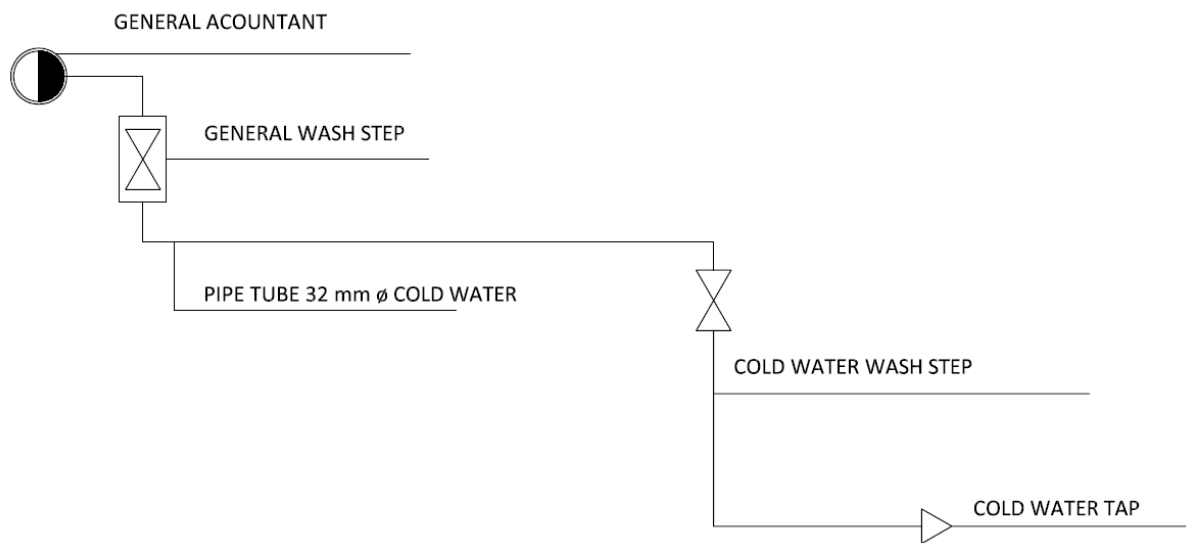

Figure 36. Temporary water supply scheme

4.1.10 TEMPORARY SEWERAGE

The sewer construction will consist in removing water from rain and the elimination of waste water as a showers, basins and toilets.

Drainage is connected to the network of urban wastewater.

The drainage plan consists in connecting our network to existing networks of the city.

The sewerage system will have a diameter of 200mm.

4.1.11 FENCE OF CONSTRUCTION SITE

The building fence will be a normal translucent fence of wire ideal for construction by the rapid assembly and disassembly solving the problem of delimitation of solar work or works. Fence height will be 2 meters. Will be needed 170.85 m for all the perimeter.

Information: http://www.rivisa.com/ficha_producto.html?cnt_id=28&ver_id=79

4.1.12 GENERAL REQUERIMENTS OF LABOR SAFETY

List of hazardous jobs in our construction:

- Working crane
- Work with hand tools and power machinery
- Welding
- Work excavators

- Working at heights
- Roof and façade installation
- Formwork installation
- Reinforcement and concrete works
- Installation works
 - Building area is surrounded of 2m high wire mesh fence.
 - Fence encloses crane dangerous and work area.
 - In construction site is being installed fire fighting shield with fire extinguishers, crowbars, shovels, buckets, box with sand.
 - All persons in the construction site must wear protective helmets.
 - For doing a work is being used only scaffolding and ladders of inventory.
 - In a construction site is being installs fire hydrant.
 - The fence of the construction is being posted with signs about imminent danger and is informing that unauthorized persons entering to the construction site is prohibited strictly.
 - All work is being made as is required in technological requirements.
 - Construction contractor before work informs employees with safe working conditions.
 - Also is determined the danger zones, they are marked with highly visible warnings.
 - Give the permits for work in dangerous zone limits.
 - Develop a list of hazardous work in a construction site.
 - If weather conditions are bad - cancel all work.
 - Workers locations should be installed out of dangerous zones.
 - Check whether the tools and appliances which are being used for work, complies all standards.
 - For each employee for service should be given a helmet, gloves, shoes with metal ends, working clothes, safety glasses.
 - Construction rubbish should be disposed of in appropriate locations.
 - Transport and traffic routes must be maintained in good order, not loaded with constructions, the road surface must be cleaned.
 - Ladders, scaffolding must comply with all safety requirements - if the scaffolds are unsteady, it should be attached with the rope to the still surface. After installation check the connections on the fasteners. If there are traffic routes near, should be installed roofs, facades and scaffolding covered with net.
 - Scaffolding and ladders are being viewed every 10 days.
 - Work at a height where protection is rope, should work qualified worker.
 - Dig trenches in sandy soils without reinforcement is possible only up to 1.25 m.
 - Raising Material or construction crane, used pallets, straps, measures preventing the lifting objects to fall.
 - It is prohibited to walk under raised structures or materials.
 - Constructions which are raised should be well fortified.
 - Should be installed fences witch to prevent falls, it may be marked.
 - When it is break time, construction or materials shall be prohibited to leave.
 - Before the roof, the supervisor must check supporting structures and enclosures; the workers must be equipped with safety equipment.
 - The materials can be packed on the roof only in the places where allows technical project and ensure that they are falling.

GENERAL PROTECTION. SAFETY LABOUR

NAME	NUMBER
Helmet	Each worker
Security gloves	Each worker
Protective clothing against mechanisms	Each worker
Protective footwear	Each worker
Protective glasses	Each worker (depending of job)
First Aid Kit	One kit
Vessel with drinking water and disposable cups	One kit

4.1.14 REQUIREMENTS OF ENVIRONMENTAL PROTECTION

Will not be able in construction site bury waste the rubbish. When construction work is completed, is required to remove construction waste, unnecessary soil, clean up area and plant the plantations.

If any of these works on time of year can't be competed, they should be finished in the next season of planting.

4.1.15 REQUIREMENTS OF FIRE PROTECTION

During construction, will be followed rules about fire protection - construction works and installation of fire protection rules.

In the future construction site in a visible and accessible place should be a panel with inventory: two buckets, two axes, two crowbars, ladders, hook, 0.5 of sand box, two fire extinguishers and two spades.

4.2 ORGANIZATION

4.2.1 TABLES OF MACHINERY AND WORKFORCE

QUANTITY OF RESOURCES IN EACH PHASE

MACHINERY	fenced plot	lower crane inst.	provisional facilities	land clearing	excavation and fundation facilities	underground sanitary	piles	pile cap	concrete structure	ceramic facade	slate facade	roof	block partitions	plasterboard partions	plastering	ceramic pav.	stone pav.	parquet pav.	tilings	paints	exterior carpentry	equipment	interior carpentry	electricity	plumbing an sanitary	heat and ventilation	fire	lifting	tests and clean	human safety, waste mgt, quality cntl			
backhoe loader				1	1																												
tower crane							1	1	1	1	1	1																					
concrete vibrator							1	1	1																								
concrete mixer truck							1	1	1																								
crane truck		1																															
piloting machine							1																										
lifting													1	1		1	1	1	1	1	1												
waste truck				1	1																												
pump truck							1		1																								
pallet										1	1	1	1																				
scaffold equipment										1	1	1	1																				
drill										1	1	1	1																				
saw										1	1	1	1																				
total	0	1	0	2	2	0	5	3	4	5	5	2	4	5	1	3	3	4	3	1	5	0	5	3	3	4	1	0	0	0	0		

WORKERS	official construction	worker construction	official carpenter	worker carpenter	official plumbing	worker plumbing	official structure	worker structure	official electricity	worker electricity	official heat	worker heat	backhoe operator	crane operator	painter	total
official construction	1	1														
worker construction	1	1														
official carpenter																
worker carpenter																
official plumbing																
worker plumbing																
official structure																
worker structure																
official electricity																
worker electricity																
official heat																
worker heat																
backhoe operator																
crane operator																
painter																
total	2	3	2	1	1	2	4	3	10	5	5	5	2	2	2	2

WORKERS AND MACHINERY SIMULTANEOUSLY PER MONTH

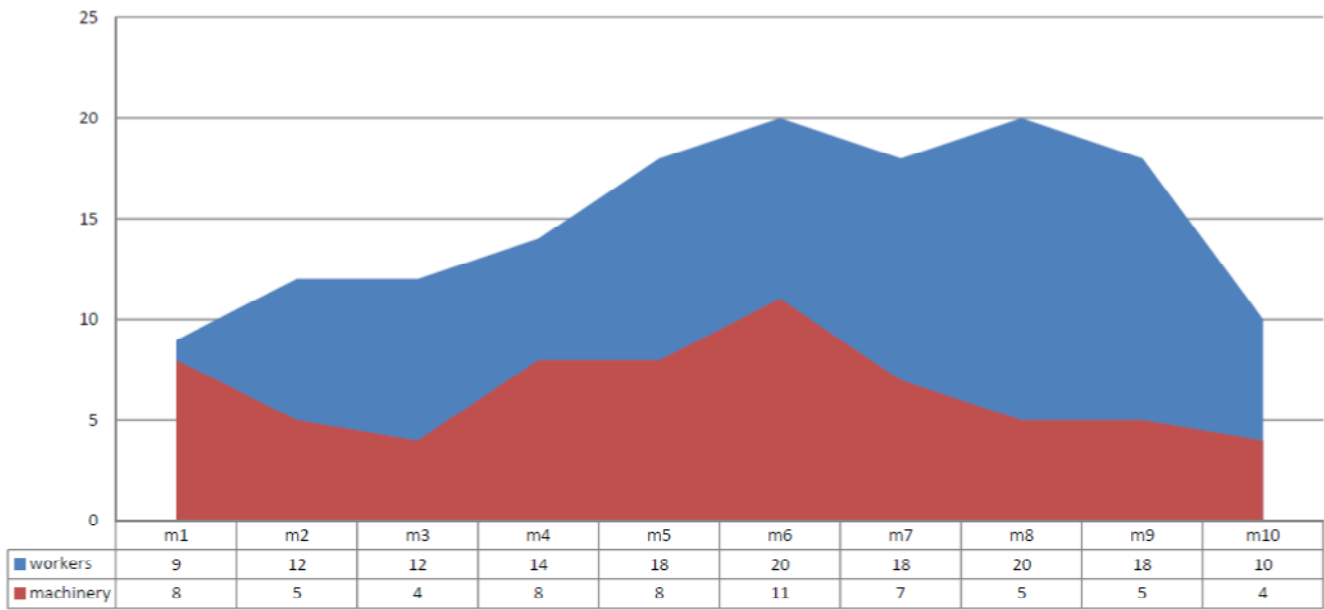

In plan of organization part you can see the Gantt Chart, and technical tables of workforce, machinery and main materials.

BILIOGRAPHY

Websites:

Liebherr webpage

www.liebherr.com

Construction fences

www.rivisa.com

Storage buildings

www.consmetal.es

Valencia Base Data of construction website

<http://www.five.es/basedatos/Visualizador/Base12/index.htm>

Plasterboards website

www.knauf.es/knauf/controller/controller.jsp

Forum soloarquitectura

www.soloarquitectura.com

Spanish construction standards

www.codigotecnico.org/web

Polytechnic university of Valencia

<https://poliformat.upv.es/portal>

Construction details

<http://detallesconstructivos.cype.es/>

Books:

-How to Design Concrete Structures using Eurocode 2/ A J Bond, O Brooker, A J Harris, T Harrison, R M Moss, R S Narayanan, R Webster.
The Concrete Centre, 2006

-Apuntes de construcción de estructuras de hormigón armado / Pascual Urbán Brotóns.
San Vicente (Alicante): (Imp. Gamma), D.L. 1999

-Construcción de estructuras : hormigón armado : detalles constructivos y perspectivas
Pascual Urbán Brotóns
Alicante: Club Universitario, 2001

- Construcción de estructuras de hormigón armado
Urbán Brotóns, Pascual. Alicante: Club Universitario , 1999

-Construcción de estructuras. Hormigón armado : adaptado a las instrucciones EHE, EFHE, NCSE-02 y CTE. Urbán Brotóns, Pascual
San Vicente, Alicante: Club Universitario , 2009

-Construcción de estructuras : hormigón armado : detalles constructivos y perspectivas
Urbán Brotóns, Pascual
San Vicente, Alicante: Club Universitario , 2009