

Document downloaded from:

<http://hdl.handle.net/10251/176407>

This paper must be cited as:

López González, MC.; Marín-Sánchez, R. (2020). Ashlar Staircases with Warped Vaults in Sixteenth- to Eighteenth-Century Spain. *Nexus Network Journal (Online)*. 22(4):959-981. <https://doi.org/10.1007/s00004-020-00519-8>



The final publication is available at

<https://doi.org/10.1007/s00004-020-00519-8>

Copyright Springer-Verlag

Additional Information

Títol: WARPED VAULTS ON STONE STAIRWAYS (XVI-XVIII c)

Author:

Concepción López González. Universitat Politècnica de València (Spain). mlopezg@ega.upv.es

Rafael Marín Sánchez. Universitat Politècnica de València (Spain). rmarins@upv.es

WARPED VAULTS ON STONE STAIRWAYS (XVI-XVIII c)

Introduction

Stairways integrated by several straight sections over warped stone vaults with continuous encounters are a cultural fact preceding and inspiring their 17th to 18th centuries' masonry analogues. Some master builders of the times, such as Alonso de Vandelvira (ca. 1575-1591) and Joseph Gelabert (1653), pointed out the special difficulty of their design. The Valencia Stonecutters' Guild (1565) provisions stated that "only masters can trace them" (Falomir 1996: 201). In fact, this episode is only addressed by a handful of authors and quite inaccurately, being Juan de Portor y Castro (1708) the only treatise writer rigorously stating those constraints that tracers must overcome.

However, such difficulty also invites the architect to stand out when masters seek to differentiate from their competitors on the basis of their technical expertise and humanistic training. Thus, this fact contributed to giving relevance to box stairways with warped vaults from the 16th century on, as suggested by the presbyter, mathematician and trader Thomas Vicente Tosca (1727: 250) (Fig. 1-2)

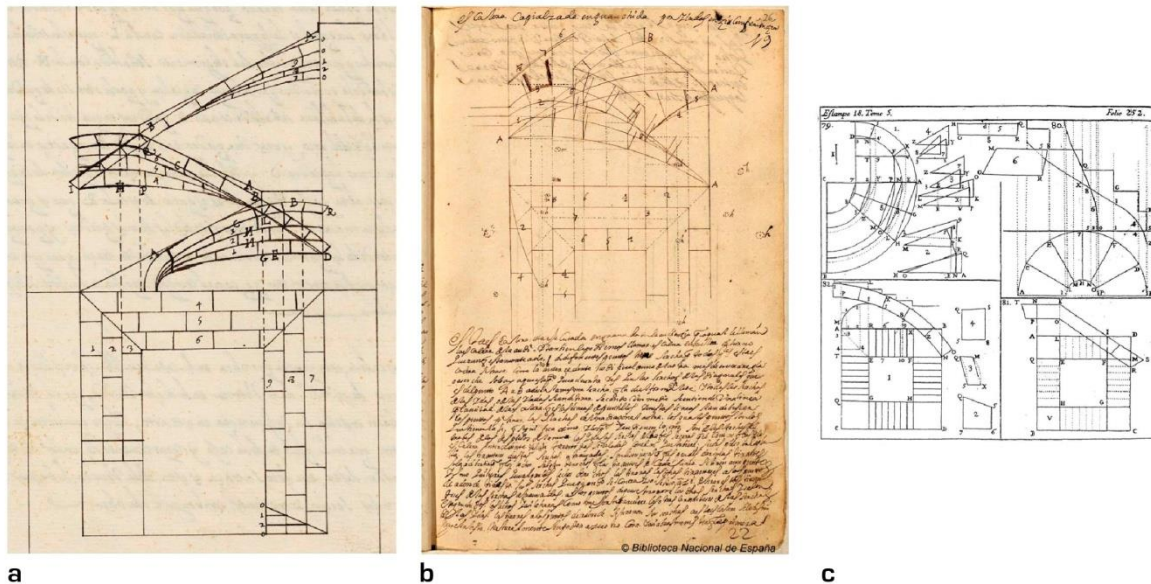

Figure 1: Trace of three-section cantilevered staircases in stone masonry treatises. a) Alonso de Vandelvira (ca. 1585), copy of Goiti (1646: pp. 102); b) Juan Portor y Castro (1708: pp. 19); c) Thomas Vicente Tosca (1727: t. 5, pp. 252).

Perhaps that is the reason why they had not yet been studied from a technical approach, except for the analysis of Gelabert's manuscript (Rabasa 2011). Strictly speaking, its design demands a deep knowledge of Euclidean geometry and a remarkable ability to reach harmony and visual coherence for a project that must be conceived in three dimensions with the rigorous fulfillment of certain geometric guidelines. The execution of the warped surfaces of its ash-lars, all different from each other, forces the examination of difficult carving operations.

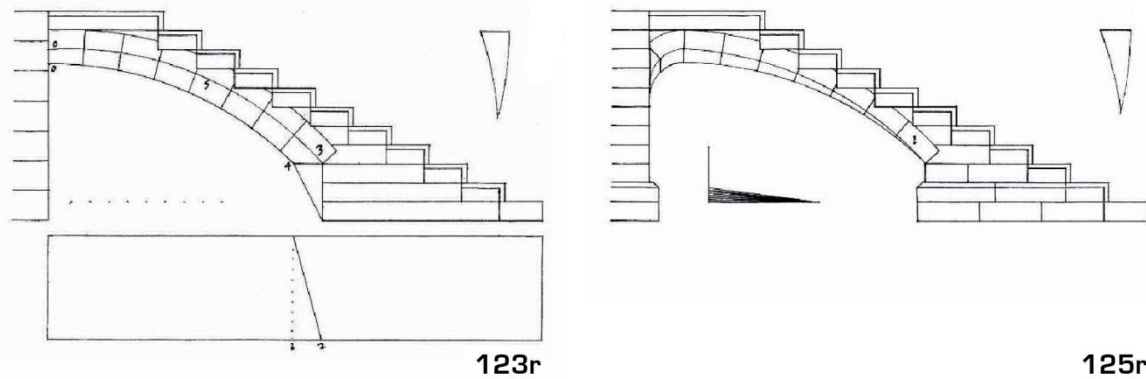

Figure 2: Trace of a cantilevered stairway in Joseph Gelabert's manuscript (1653: pp. 123r, 125r).

Although the stonecutters' ability to avoid these problems with imperceptible geometric approaches is well known, this also implies a remarkable technical expertise. In this case, the masters solved complex problems of flat geometry by fixing some difficult to determine variables as starting data. They became accustomed to the use of scalloped or basket-handle arches, that is, arches integrated by circumference fragments of different centers harmonized with each other (Huerta 2007). They even worked with two projections (plan and elevation) at once, conditioning the criteria for drawing the arcs, bed joints, etc., to specific graphic results.

These graphic operations, not entailing great difficulties nowadays, illustrate the differences between the Medieval master and those of the Modern Age, although this must be understood in terms of an adaptation to the new trends, rather than as a rupture. On these stairways, simple cylindrical vaults gave way to conical shapes and later on to complex warped surfaces. But the carving continued to be based on the use of directional curves, or more precisely, on the lines defining their edges and not on the projection planes themselves.

The examples of complex stairways emerging in the 15th century and consisting of several vaulted sections with continuous encounters are found in the maritime kingdoms of the crown of Aragon. Instead, the presence of Modern Age box stairways is limited to the kingdom of Valencia and its surroundings. There is, therefore, a direct relationship between the number and technical quality of the preserved examples and the degree of technical evolution in each region. In Valencia, the connection between these innovations and the double-curved groined vaults introduced around 1450 by Francesc Baldomar seems clear, and constituted an unparalleled solution at that time (Zaragozá 2010: 187-224).

Reference models

A. One-section Medieval stairways in the Mediterranean region

Mediterranean Medieval noble houses were built around an inner courtyard with a stone stairway to access the noble floor, most likely being the fortified architecture their immediate precedent. The most ancient stairways of this construction type are the one-section stairways resting on a narrow span pointed vault leaning on thick walls.

1
2
3
4 In the second half of the 14th century, vaults were lightened to cover wider spans. They were
5 lowered and the run was occasionally fragmented into several sections that, in a first stage,
6 remained aligned. The most ancient stairways, dating from the 13th century, are found in the
7 *Apulia federiciana*. That same pattern was later adopted in Naples, Sicily, Mallorca, Catalonia
8 and Valencia, the relevance of each piece depending on its size and on the guardrails' decorative
9 richness (Zaragozá et al.: 2019).

10
11 The vaults of these early examples are of cylindrical shape and very simple tracing. To carve
12 the voussoir, header's templates or a *bevel* were used. Additionally, employing segmental arcs
13 also allowed for a better adjustment of the vault to the slope of the steps, saving stone and
14 reducing the weight. (Fig. 3)

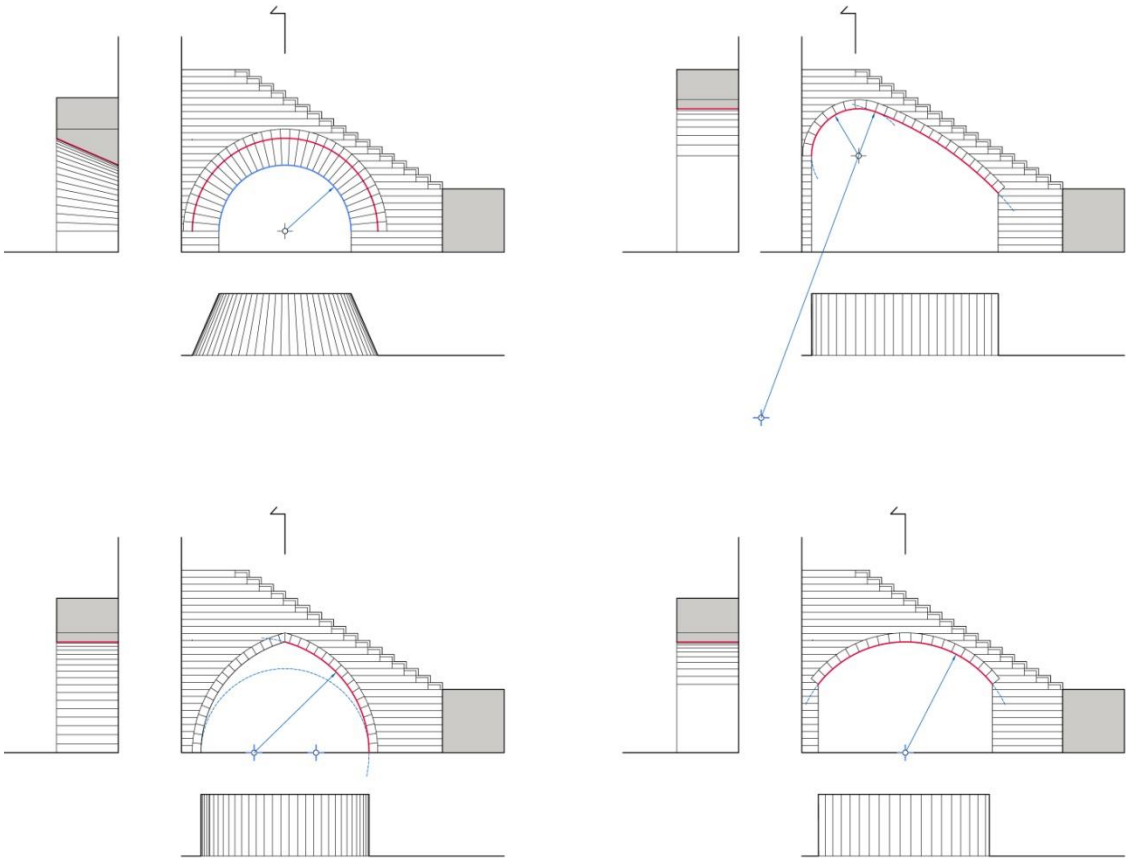

15
16
17
18
19
20
21
22
23
24
25
26
27
28
29
30
31
32
33
34
35
36
37
38
39
40
41
42
43
44
45
46
47
48
49 Figure 3: Trace of a cantilevered stairway with conical and cylindrical vaults and influence on the supporting
50 walls. Drawing by the authors.

51
52
53 Later on, the intermediate pillars were replaced by corbels, which disappeared as the vaults'
54 span increased and their shape evolved. To take advantage of the stairwell for domestic pur-
55 poses or to lighten the load, either the opening or outer edge of the vault was raised. This
56 caused the cylindrical shape of the ancient barrel vault intrados to adopt a shape that is closer
57 to the cone, subsequently evolving into warped shapes.

The result of this first evolution was the "*capialzada*" stairway, which has one of its opening curves elevated forming a tapering vault. Its intrados approaches the cone when concentric curves are used on both ends, but also gives rise to more complex shapes. Its first applications to stairway vaulting took place in Valencia, according to some contracts where the adjective "*capçalat*" or "*capalçat*" is mentioned (Gómez-Ferrer et al. 2004; Gómez-Ferrer 2005). (Fig. 4)

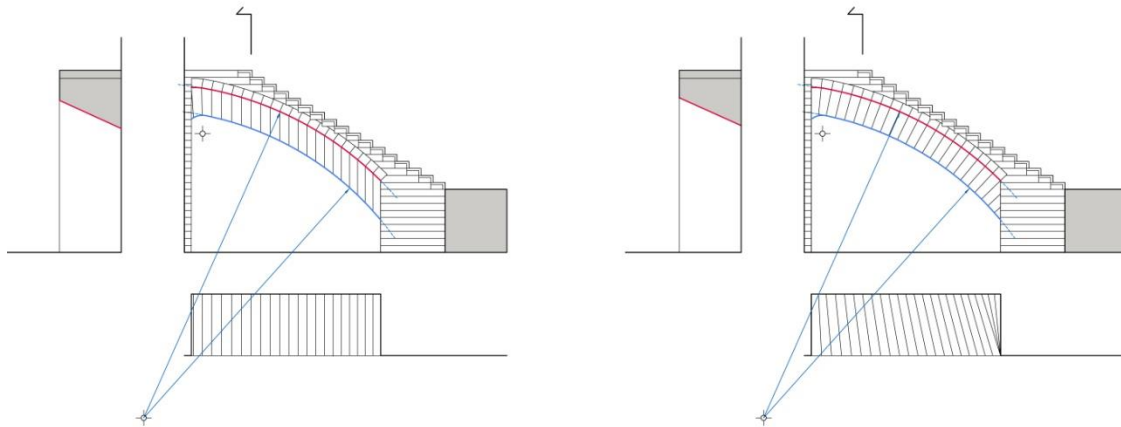

Figure 4: Trace of a cantilevered stairway over conical vaults (*capialzada*) and buttressed arch. Influence on the supporting walls. Wall arch (blue) and cantilevered arch (red). Drawing by the authors.

In this variant, the trace is further complicated by the fact that all the voussoirs are differently shaped. The front arches, generally concentric, now have a different chord length, thus requiring different header templates producing a slight warping of the transverse joints or bed planes. In practice, the key of the design lies in the orientation criteria used to arrange those bed joints in the vertical projection.

According to historical documents (Gómez-Ferrer 2005: 132), there was a variant named "*capialzada de otra manera*" stairway, or "*engauxida*" (skewed) by Gelabert (1653: 123r). It is a more complex type of *capialzado* where the opening curves are not concentric. In that case, although both traces arise at the same height, the outer line rises above the inner one reaching a higher level throughout its trajectory. This causes the formation of a warped surface of very complex carving. As in the previous case, each voussoir is different, but here the problems are enhanced; each ashlar's bed joints require a specific cutting pattern and the warping of the voussoirs' intrados must be intuited from the directional curves defining their four edges. Furthermore, their front edges are shaped by tangent circumferences of different radii, adding greater difficulty. Therefore, the use of this variant can only be understood as a design constraint or as a boast of knowledge. (Zaragozá et al. 2019: 13). (Fig. 5)

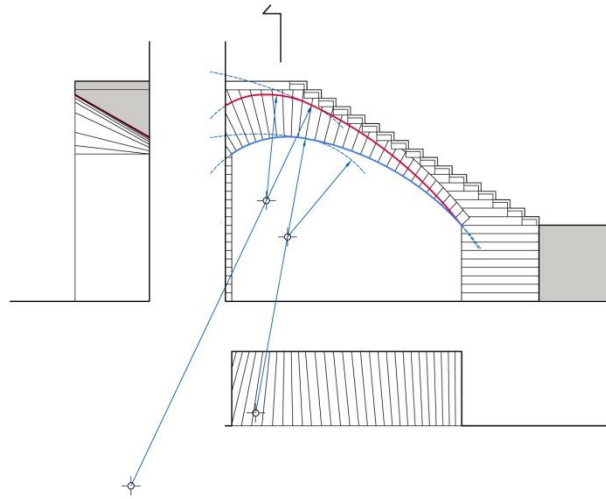

Figure 5: Trace of a cantilevered stairway with “engauchida” vault. Influence on the supporting walls. Wall arch (blue) and cantilevered arch (red). Drawing by the authors.

B. Late Medieval stairways of several sections

At the end of the 15th century, one-section courtyard staircases evolved into the two-section types, to which a corridor with one or several lowered vaults on abutments or corbels was added. This innovation forced to match their encounters. It seems that the solution reached full maturity on the stairways designed by Pere Compte for the new courtyard of the *Palacio de los Borja*, in Valencia (1485). This piece could be the first example of a three section C-shaped stairway with “by edge and rounded” vaults’ encounters (Zaragozá et al. 2019: 15).

It seems that the encounters by edge were the first ones to arise, inspired by the Valencian groined vaults of the 15th century (Navarro and Rabasa 2018: 145). In a clever way, it was decided to define the edge’s directional curve in true magnitude, assigning an arbitrary tracing radius to overcome the difficult encounter between two warped shapes. That way, the complex cutting of the corner pieces could be undertaken by means of carving operations similar to those used for the rest of voussoirs.

On the other hand, rounded encounters admit several solutions. It is possible to first conceive a flat vault to later give it the curvature calculated on the basis of the contour edges (Equizzi 2019, 94-97). Or, as Portor pointed out (1708, 35v), it can be projected as a convex surface (groined) and then give it concavity (Navarro-Camallonga 2019).

Several section staircases with continuous encounters

In the 16th century, the staircases gained relevance as a ceremonial and as a spatial articulation element. This favored the adaptation of the three-section Late Medieval format to two novel variants with a clear compositional vocation and notable technical flair. This process benefited from previous contributions by master masons Dalmau, Baldomar and Compte.

1
2
3
4 Towards 1566, Joan Anglés tried for the first time to incorporate all the innovations of the
5 courtyard stairs with continuous encounters on the cloister stairway of the *Convento de Santo*
6 *Domingo de Orihuela* (Alicante). This proposal was then replicated by Joan de Ambuesa in the
7 monastery of *San Miguel de los Reyes* in Valencia (1580-1583) and later refined by Francisco
8 Figuerola at the *Corpus Christi* seminary in the same city (1598-1601). The latter is the best of
9 the series (Marín and López 2018: 11). (Fig. 6)
10
11

12 In 1600, Joan Cambra composed two symmetrical three-section C-shaped courtyard stairways,
13 creating a pre-imperial layout for the new stairway designed for the southern courtyard of *San*
14 *Miguel de los Reyes*. According to the work contracts, the first exploratory stage in search of
15 new types of stairways dates back to the time when Covarrubias was in charge of the works
16 (ca. 1548). Years before, an even more effective solution had been proposed by Joan de Am-
17 buesa for the claustral stairway at the cloister's Northeast flank, consisting of doubling, in a
18 symmetrical manner, the stairway which today is preserved in the North tower. (Fig. 6)
19
20

21 This unexecuted project started an in-depth debate that remained latent until the 18th century.
22 That is the case of the *Casa Aduana Real* of Valencia's stairway (1762), currently the head-
23 quarters of the Superior Court of Justice. It was a building designed by Felipe Rubio y Mulet
24 (c.1767) as an access exam for honorable academicians of the Academy of *San Fernando* in
25 Madrid (Bérchez 1993: 134). The *Casa Aduana Real* is considered to be the most important
26 work of the Valencian 18th century, housing relevant stonework by Antonio Gilabert, who is
27 attributed the project of the two inner box stairways, symmetrically arranged in the central hall
28 (Bérchez 1987: 10-12). (Fig. 6)
29
30
31



58 Figure 6: Current status of the study cases: a) Stairways of *Santo Domingo* (Orihuela); b) *Corpus Christi*
59 (Valencia); c) *San Miguel de los Reyes* (Valencia); d) *Aduana Real* (Valencia). Pictures by the authors.
60
61
62
63
64
65

1
2
3
4
5
6 Thomás Vicente Tosca (1727: 250-252 stamp 18), presbyter, mathematician and treatise writ-
7 er, also echoed this technical problem that remained unsolved in the architecture of the times
8 and that was directly linked with his concern for the application of mathematics to the science
9 of stereotomy.

10
11 The outstanding examples cited encouraged the dissemination of this typology throughout
12 Spain, reaching as far as France (Zaragozá 2013). The connection of Valencia with some Cas-
13 tilian examples such as the stairway of the *Real Chancillería de Granada* (Salcedo 2017) or
14 that of the *Monasterio de Uclés* (Cuenca) remains unsolved. The French episode is limited for
15 now to a piece of clear Valencian precedents (Zaragozá et al. 2012): the missing stairway of
16 the archives of the Toulouse town hall, by Benoît Augier (ca.1530-1531). According to Pérouse
17 de Montclós (1982: 86), it is one of the greatest unknowns of the French architecture.

18
19
20 At technical level, the project of these stairways consisted in obtaining all the edge lines or
21 directional curves outlining the ashlar's faces, fundamentally integrated by simple circumfer-
22 ence arcs. Therefore, their design consisted on obtaining, for each section, the curve enclosed
23 in the plane of the wall, that of the parallel plane in the outer edge of the vault and the lines
24 (straight or curved) completing the transverse planes of the vault's voussoirs (Marín and López
25 2018: 6).

30 **Working methodology**

31
32 The present research work entails several working phases. In the first instance, an inventory of
33 this variant of stairs was compiled. In the old kingdom of Valencia there are five pieces stand-
34 ing out above all due to their exceptional nature. Of these, the most ancient one is found in the
35 *Monasterio de Santo Domingo de Orihuela* and the others are preserved in Valencia: the two
36 exemplars (one claustral and one imperial) at the *Real Monasterio de San Miguel de los Reyes*
37 of Valencia; the claustral one of the *Real Colegio Seminario de Corpus Christi* and the claustral
38 double stairway of the ancient *Casa Aduana Real*, which is the most recent one.

39
40
41 Afterwards, we carried out the graphic survey of the stairways as a necessary step for its sub-
42 sequent geometric analysis (Almagro, 2019: 5). A Faro 3D terrestrial laser scanner (TLS), Fo-
43 cus 3D-130 model, was selected to overcome the constraint posed by the complex shape of
44 the vaults. Its low weight (5.2 kg) and small size (24x20x10 cm) simplified its use and transport.
45 The device also includes an integrated 70 megapixels camera allowing obtaining photo-
46 realistic point clouds, and its FLS format files are compatible with all the processing software.
47 Its systematic distance error (2 mm in 25 m) is perfectly acceptable for the purpose of this
48 study. It provides a high number of easy-to-use points for the subsequent analysis of the traces
49 and, in addition, it allows scaling orthophotos enabling direct geometric analysis.

50
51
52 A scanning station was programmed on each stairway landing to ensure a good overlap of the
53 shots and the correct registration of cloud points, without blind spots. The processing of the
54 scans was performed using Scene version 19 software. (Fig. 7)

1
2
3
4
5
6
7
8
9
10
11
12
13
14
15
16
17
18
19
20
21
22
23
24
25
26
27
28
29
30
31
32
33
34
35
36
37
38
39
40
41
42
43
44
45
46
47
48
49
50
51
52
53
54
55
56
57
58
59
60
61
62
63
64
65

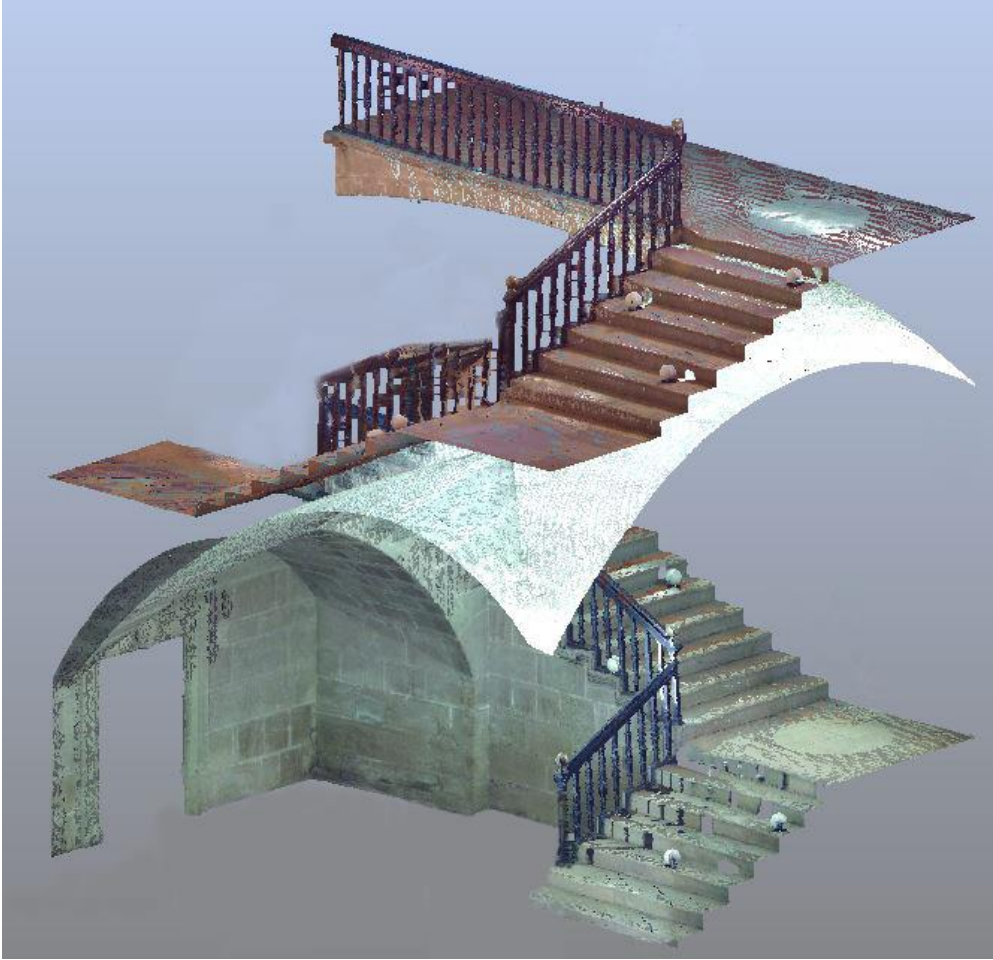

Figure 7: Digital image and 3D point clouds of the *Santo Domingo* stairway (Orihuela). Image by the authors.

Graphic analysis was performed, since it allowed for recognition of the original geometry (Spallone, 2019: 80). The possible trace has been empirically determined directly on the cloud points, following the premises given in the stonecutting manuscripts by Vandelvira (1575-1591), Portor and Castro (1708) and Tosca (1727), the only Spanish authors dealing with this type of stairway. Furthermore, this method allows for a better weighting of design errors, deformation, collapse and the exact exploded view of the ashlar.

Based on the previous work, a graphic trace hypothesis was drawn up for the two outer longitudinal sections of each run, assuming the existence of a common pattern applying to all of them. Next, the curvature of the transverse sections of the intrados or "capialzo" was determined. The definition of the curves of all of the ashlar's edges allows its direct carving with the aid of a ruler. All this taking into consideration the equivalences in the traditional units of measurement as an additional guarantee of reliability.

Based on the concise explanations given by Alonso de Vandelvira and Juan de Portor, we were able to first obtain the radii of the openings or directional curves of the stairwell and subsequently those of the encounter with the wall. The analysis begins at the impost, by linking the arches of each section with their contiguous in the landings' turning angles. Both authors noted

1
2
3
4 the need to ensure correspondence of the curvatures of each vault with that of the next run.
5 Father Tosca also established that the thickness of these vaults should measure between a
6 hand span (palm) and a foot (22-30 cm).
7

8
9 None of the authors offered detailed guidelines to calculate the radii and determine the trace
10 centers of these arcs. However, they agree that they must meet two criteria: to be tangent to
11 the auxiliary line joining the "teeth" of the steps' treads and risers (or to approach it as closely
12 as possible); and, in addition, to force its trajectory through a pre-established point at the junc-
13 tion of two contiguous sections' meeting planes, so that all the vaults appear to have continuity.
14 The graphic solution for this geometric challenge could entail great difficulty; however, it might
15 be skillfully solved by fixing the position of the tangent line, the crossing point and the radius of
16 the arc linking both as starting data. With these premises, the solution is immediate with the
17 simple geometric construction shown in Figure 8.
18
19

20 Of all the authors, only Juan de Portor took the time to explain some of the issues entailing
21 higher difficulty, such as the tracing of the landings' edges and that of the voussoirs bed plane
22 edges. It is done sometimes in an explicit manner throughout his texts and, others, by means
23 of the graphic operations implicit in his traces.
24
25

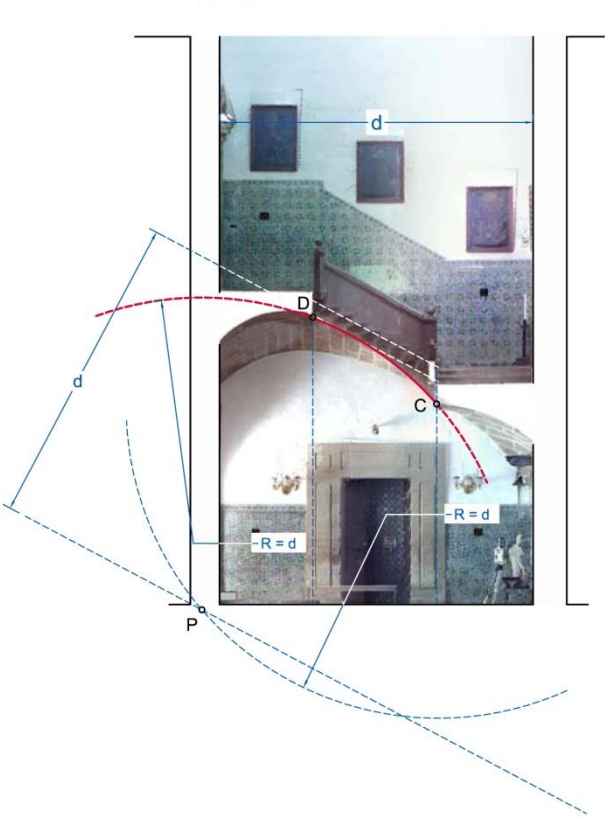

26
27
28
29
30
31
32
33
34
35
36
37
38
39
40
41
42
43
44
45
46
47
48
49
50
51
52
53
54 Figure 8: Correct procedure to determine the curvatures of the vaults with known arc radius, passage point
55 and tangent line values. First, a parallel is drawn at a distance (d) from the auxiliary line located at one foot
56 distance from the steps. Then, a circumference of radius (d) is drawn with center at point (C) (which is a
57 datum obtained during the tracing of the lower section), which, at its intersection with the previous line, pro-
58 vides the center (P) to draw the stairway arch. Drawing by the authors.
59
60
61
62
63
64
65

Study cases

A. Stairway of the *Colegio de Santo Domingo de Orihuela*

The stairway of the *Monasterio de Santo Domingo de Orihuela* was designed and built by the master Joan Anglés, from Tortosa (Tarragona). It is located in the corridor connecting the two cloisters of the monastery and it gives access to an intermediate story and to the upper floor. It is enclosed in a markedly square box of 7.18 x 7.22 meters. It has five sections and a landing gallery. The first two runs are blind, while the remaining three and the gallery are supported on vaults with warped intrados. All the joints of the vault sections under the landings are encounters by edge, except for the one of the fifth section with the gallery, which is rounded. The ash-lars are arranged perpendicular to the walls of the box, although their bed planes are hidden under a coating of false mortar joints.

The steps are one-piece. They are built of large stone slabs not resting on the vault; instead, they integrate within it in order to reduce the weight and provide greater stability to the steps. This particular feature of Valencian stairways forces to cut the extrados of the vault's ashlars allowing laying out the steps *a montacaballo*. Similarly, following the Mediterranean tradition, the outer planes of rises and treads are finished with a decorative molding to avoid reducing the steps' width.

To discern the tracing method followed by Anglés, we proceeded to simulate all the operations that the author must have followed when projecting the piece. Starting by distributing the steps and creating the existing landing planes, which Anglés most likely reconsidered previously, and following the treaties sources, we traced the auxiliary line joining the "teeth" of said steps and its parallel to a foot of distance. Due to Joan Anglés' origins, we used the *Tarragona foot* (0.26 m) as measuring unit. Also, we were able to ascertain that the arches were effectively projected in ascending order, starting with the first vaulted section. In the starting run, the trace was made on the basis of three pieces of information fixed by the master: the width of the vault on its outer edge, which is one foot thick; the radii of curvature of the outer edge and the wall's arches, which are always the same and equal to half of the stairwell's width; and the tracing center is located at the midpoint of the next section. With this data, the two arches delimiting the vault are drawn to obtain the corresponding templates and formwork. The vault's thickness is fixed by drawing the parallel at one foot distance from the auxiliary line joining the "teeth" of the steps.

In the trace of the remaining sections, one of the three starting data is modified. In this case, the tracing center of the circumference is not a given piece of information but the solution to the graphic problem. It should be kept in mind that each vault must encounter the one from the previous section at a point located at the turning of two consecutive runs. Therefore, the vault's starting point is one of the set initial conditions. The remaining two, as in the first case, will be the depth of the vault (one foot thick); and the radii of curvature of the outer edge and the wall's arcs, which in this instance are equal to the width and half width of the box, respectively. This criterion followed in choosing the radii was previously used in Medieval courtyard stairways, perhaps because it was an easy rule to remember. To find the geometric point on the center of the wall's arc, the floor plan projection of the vaults' arrises (landing's diagonal). It is a simple geometric problem that can be undertaken with two chords. (Fig. 9-10)

	Section length	Directional curve radius (box)	Directional curve radius (wall)
Section 01	6.81 (35 Tarragona palms; T.p.)	Solid	Solid
Section 02	7.22 (37 T.p.)	Solid	Solid
Section 03	7.18 (21.5 T.p.)	3.57 m. = half box width	3.57 m. = half section width
Section 04	7.22 (37 T.p.)	7.20 m. = box width (d4)	3.60 m. = landing diagonal
Section 05	7.33 (37.5 T.p.)	7.33 m. = box width (d5)	3.68 m. = half box width
Naya (landing corridor)	7.22 (37 T.p.)	10.85 m. = 1+1/2 box width	10.85 m. = 1+1/2 box width

Hypothesis of the tracing process:

- Cantilevered arch tracing process (fig 9 section 4 cantilevered arch): 1. The steps are drawn on the wall; 2. Line AB is drawn 0.26 m (1 Tarragona foot) from the line of the steps; 3. Line AB is transferred to the floor with its slope; 4. A parallel to AB (A'B') is drawn at a distance equal to the width of the staircase box ($R = d4$); 5. An arc of radius $d4$ is drawn from point C (hinge point); 6. The cut point with A'B' is the center of the cantilevered arch that is drawn on the floor. With this arch, the formwork is built for the formation of the vault. This construction is performed on the ground (plan) due to the fact that the center is below the ground line. This circumstance prevents from tracing it on the wall. For this same reason, the radius of the arch is never greater than the width of the staircase box.

- Wall arch tracing process (fig. 9 section 4, wall arch): 1. The radius dimension = diagonal of the upper landing, EF, is prefixed; 2. The arch starting point at the hinge C is known; 3. The other point (end of the arch) is found by transferring to the floor the encounter arch between two consecutive vaults, taking as its center the same as that of the cantilevered arch; 4. The height of the encounter arch is F (H); 5. With this piece of information, point E is placed on the wall; 6. Knowing the two points C and E and the radius EF, the center of the arch is found.

- Process of drawing the cantilevered arch for section 3 (fig. 9 section 3): 1. The tangent line to the steps is drawn at a distance of 1 foot (AB); 2. A parallel line is drawn at a distance equal to half the width of the stairway; 3. The cut-off point with the center of the upper landing is the center of the cantilevered arch. The wall arch has the same radius and its center is found in the center of the arch span. This construction can be done interchangeably on the ground (plan) or on the wall (elevation) because the center is above the ground line. The wall arch has the same radius and its center is at the midpoint of the arch span.

- In section 5, the procedure is exactly the same as in section 4's cantilevered arch (Fig. 10 section 5). The wall arch has the same radius of curvature as the cross section of the naya for favor the rounded encounters.
- The radii of the cantilevered and the wall arches of the vault supporting the naya are equal to and equivalent to one and a half times the width of the staircase box (Fig. 10 section 6).

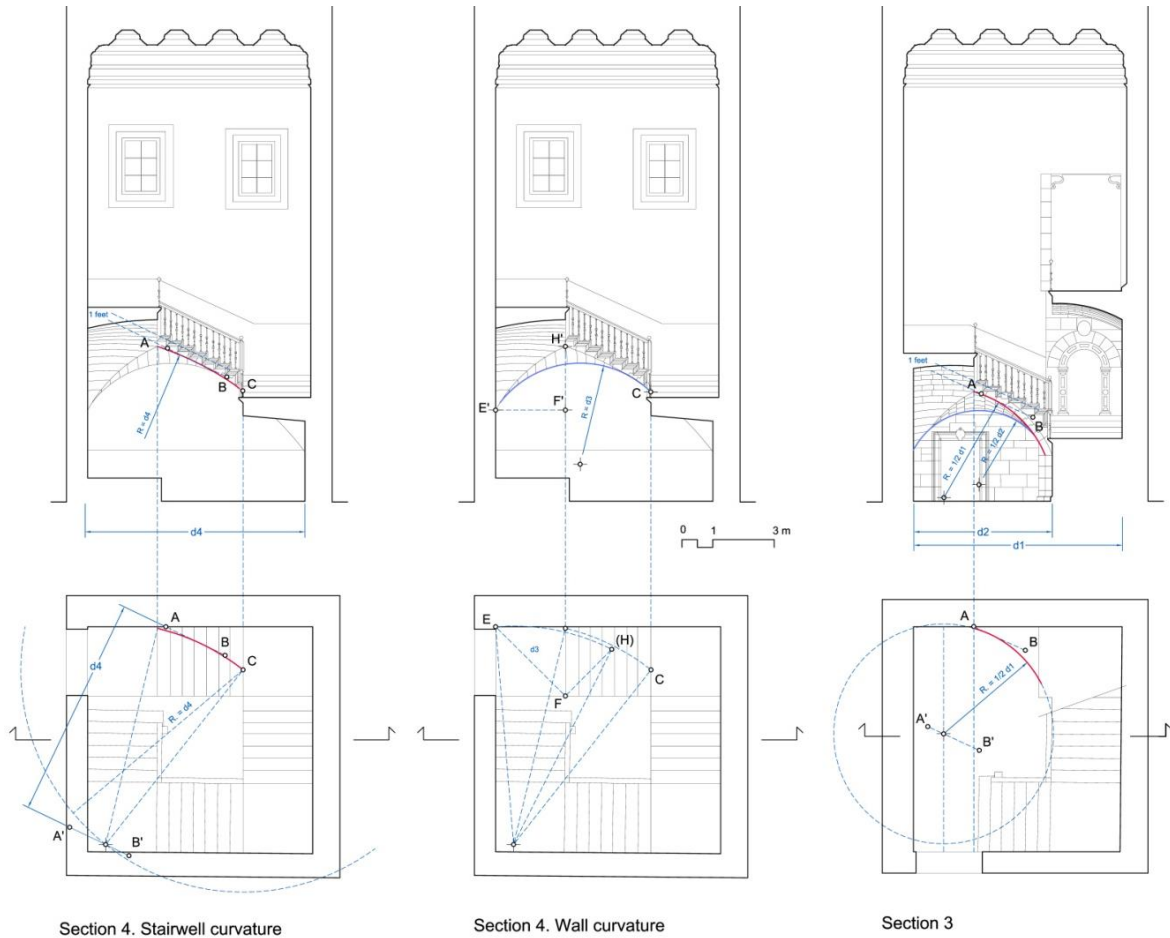
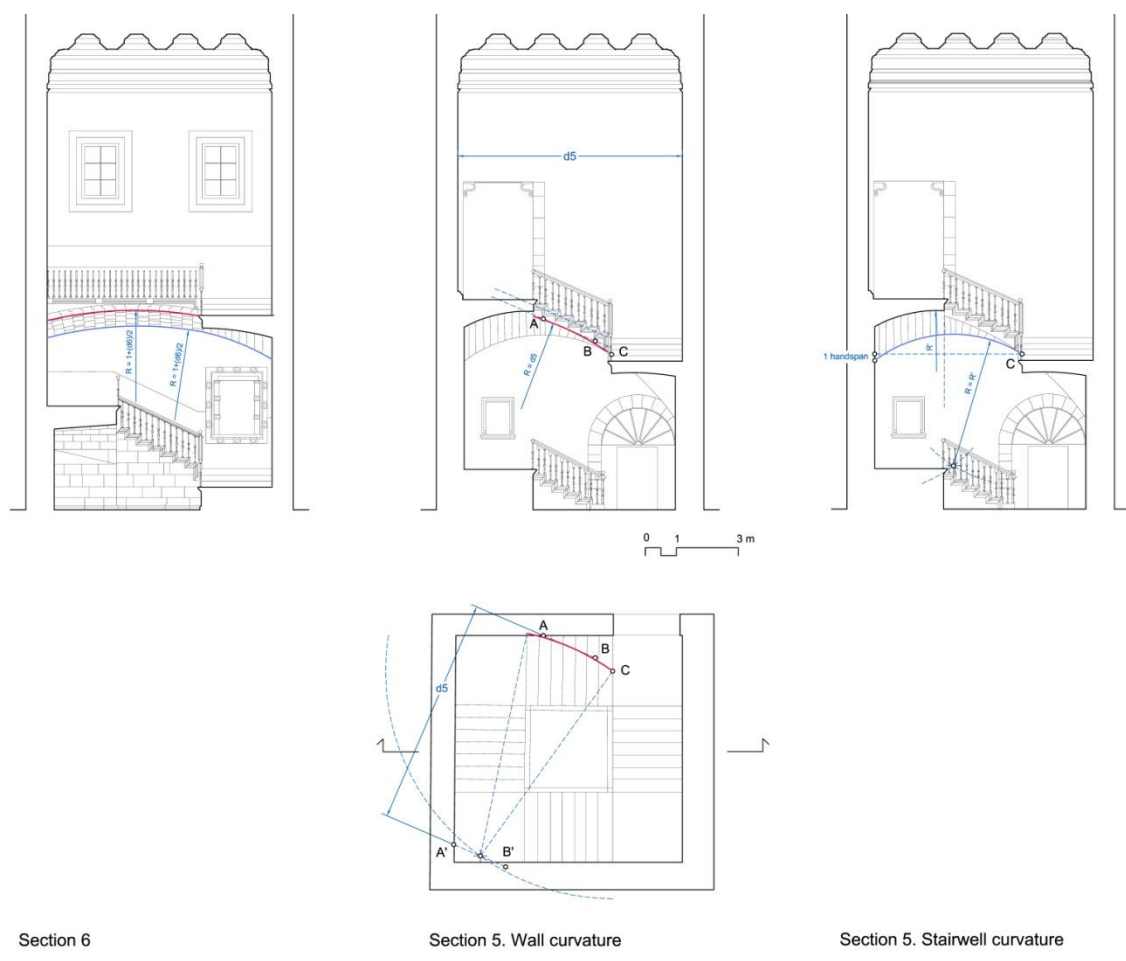

Figure 9: Tracing hypothesis of the *Santo Domingo* stairway (Orihuela). Sections 3 and 4. Drawing by the authors.

1
2
3
4
5
6
7
8
9
10
11
12
13
14
15
16
17
18
19
20
21
22
23
24
25
26
27
28
29
30
31
32
33
34
35
36
37
38
39
40
41
42
43
44
45
46
47
48
49
50
51
52
53
54
55
56
57
58
59
60
61
62
63
64
65



Section 6
Section 5. Wall curvature
Section 5. Stairwell curvature

Figure 10: Tracing hypothesis of the *Santo Domingo* stairway (Orihuela). Sections 5 and 6. Drawing by the authors.

B. Stairway of the *Colegio del Corpus Christi*

It is the most relevant example of the series for its exquisite execution technique and its larger scale. It is enclosed in a tower of markedly square plan of 7.82 x 7.42 meters (about 26 x 24.5 Valencian feet, 30.2 cm), delimited by rammed earth Valencian walls 21.2 meters high and 0.90 m thick. It is composed of six sections, while the usual number was three, five of them being cantilevered, and it was built in two phases. The first five sections were projected by Francisco Figuerola between 1598 and 1601, while the last one was added in 1602 by Joan Baixet, Joan María and Bartolomé Abril to give access to the library (Benito 1981: 76). Most of its vaults give rise to forceful corner joints beneath the landings evoking Francesc Baldomar's *tas-de charge* springers. The only exception is the connection with the corridor, as it is conditioned by the encounter with the *capialzado* vault.

The methodology used in our study was the same as in the *Santo Domingo* stairway, verifying that in both of them the tangency of the vault's outer edge to the straight line located at one foot distance from the auxiliary line joining the "teeth" of the steps has been maintained. This ensures the minimum thickness of the vault, regardless of the metrological system used. In

both cases the width of the box is used as the radius of curvature of both the outer edge and the wall arcs, except for the first vaulted section whose radius is half of that.

As a particular feature, the wall curves at the third and fourth sections are integrated by two arc branches since the design of transverse or bed joints of these stairways has utilized a directional curve. It seems that the centers of these arcs were arbitrarily obtained on the elevation itself given that they coincide with singular points of it and even suggest a compositional intention, perhaps prompted by the presence of two doorways. Figuerola, however, had the ability to place these centers on the segment joining the point of tangency of both curves with the center of the greater arc, ensuring a perfect encounter.

Likewise, the radii of the bed joints also seem to have been defined directly, without mediation of a previous trace, adopting the same values of the directional curves of each of the affected sections' voids. (Fig. 11)

	Section length	Directional curve radius (box)	Directional curve radius (wall)
Section 01	7.40 m. (24.5 Valencian feet; V.f.)	Solid	Solid
Section 02	5.22 m. (17.3 V.f.)	5.28 m. = section length	2.72 m. = ½ box width
Section 03	7.85 m. (26.0 V.f.)	6.05 m. (20.0 V.f.)	6.05 m. = directional curve (box)
Section 04	7.40 m. (24.5 V.f.)	7.40 m. = box width	7.40 m. = box width
Section 05	7.85 m. (26.0 V.f.)	7.85 m. = box width	7.85 m. = box width

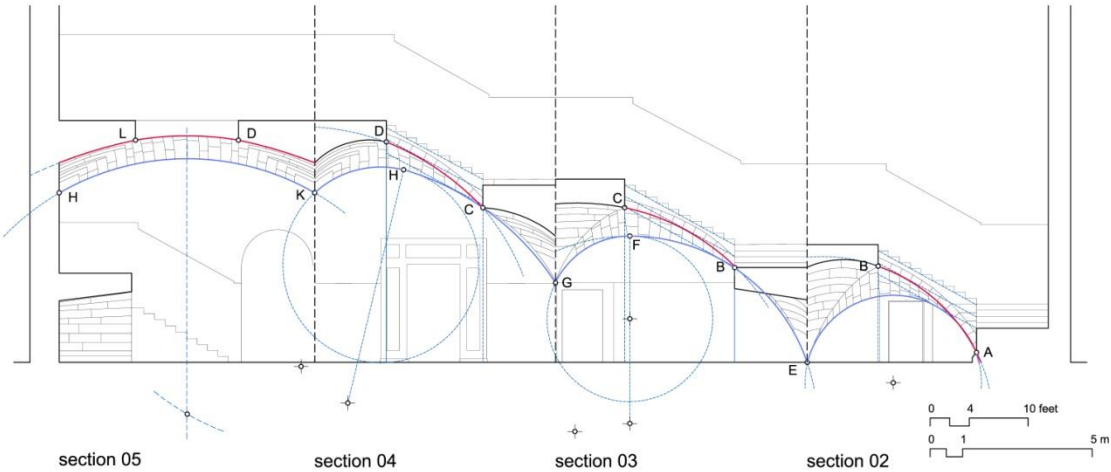

Figure 11: Extended tracing hypothesis of the *Corpus Christi* stairway (Valencia). Drawing by the authors.

C. Imperial stairway of *San Miguel de los Reyes*

This stairway has been highly valued for its innovative composition, although at a technical level it does not offer major developments. Despite being built shortly after those at the *Orihue-la* or *the Corpus Christi* Colleges, its repertoire of possibilities is less refined and it seems to have taken its courtyard predecessors as direct technical referents.

The stairway is enclosed in a rectangular box of 7.37 x 17.15 meters (35x82 Castilian palms). It starts from a blind central section from which the two return runs arise.

After performing the graphical analysis, it can be observed that both runs show some differences. While the left run follows the criteria and methodology used in the two previous stairways, in the right run, dimensions are altered, which suggests it was performed by a different architect.

Overall, it suggests an inadequate command of the technique affecting both the project and the carving process. Its master did not manage to skillfully sort out the constraints involved in adapting this stairway to a space with several accesses and circulation paths. It seems that he only used the projection of the elevation to trace the voussoirs. This resulted in very steep and irregular transverse courses, to which many other imperfections were added, such as the disorganized rake of the voussoirs' radial joints. This, in addition to other facts lead us to think that its ashlar could have been laid out on site, through a process similar to that used for the severies at *La Lonja de Valencia*, as later detailed by Gelabert (1653: 151v-154v). (Fig. 12)

Left stairway:

	Section length	Directional curve radius (box)	Directional curve radius (wall)
Section 01	7.34 m (35 Castilian palms; C.p.)	solid	solid
Section 02	7.09 + 3.4 = 10.49 m (50 C.p.)	7.37 m = box width	5.21 m = ½ section 2 length
Section 03	7.34 m (35 C.p.)	10.11 m = section 2 length	17.15 m (82 C.p.) = box length

Right stairway:

	Section length	Directional curve radius (box)	Directional curve radius (wall)
Section 01	7.34 m (35 Castilian palms; C.p.)	Solid	Solid
Section 02	6.91 (33 C.p.) + 3.2 (14 Valencian palms.) = 10.11 m	6.78 m = distance between supports	4.31 = total run
Section 03	7.34 m (35 C.p.)	17.15 m (82 C.p.) = box length	10.29 m = section 2 length

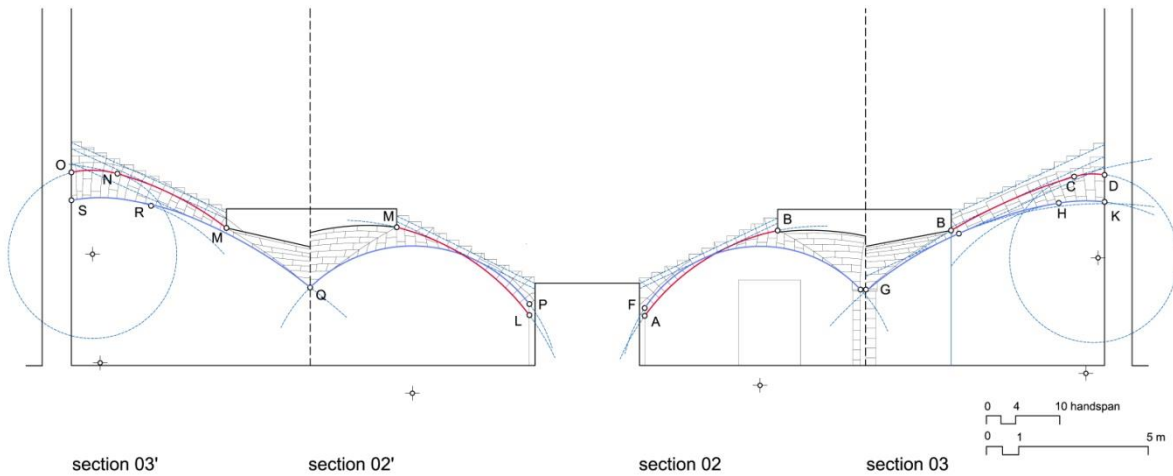

Figure 12: Extended tracing hypothesis of the *San Miguel de los Reyes* stairway (Valencia). Drawing by the authors.

D. Stairway of the *Aduana Real de Valencia*

The trace of this stairway is attributed to Antonio Gilabert (Bérchez 1993: 134), who might have been inspired by an old abandoned project for the monastery of *San Miguel de los Reyes*. It is a three-section double stairway enclosed in a square plan of 6.80 meters on each side (30 Valencian palms of 22.65 cm/each).

Its technical analysis demonstrates Gilabert's acquaintance with the project's criteria followed by its predecessors, built 160 years earlier. He undertook its trace as an academic exercise of the highest mathematical rigor. As Tosca previously suggested, it seems that Gilabert took into consideration both the floor plan and the elevation projections simultaneously in order to achieve a coherent geometric construction. This could perhaps serve as a general project rule for this typology (Fig. 13). Bed joints are perpendicular to the wall and the ashlars are regular in size. Only three different voussoir layouts were used on the straight runs, a distribution that unavoidably had to rest on the plan.

	Section length	Directional curve radius (box)	Directional curve radius (wall)
Section 01	6.80 m (30 Valencian palms; V.p.)	Solid	Solid
Section 02	6.80 m (30 V.p.)	3.62 m (16 V.p.)	2.49 m (11 V.p.)
Section 03	6.80 m (30 V.p.)	6.04 m (26.5 V.p.)	9.42 m (41.5 V.p.)

1
2
3
4
5
6
7
8
9
10
11
12
13
14
15
16
17
18
19
20
21
22
23
24
25
26
27
28
29
30
31
32
33
34
35
36
37
38
39
40
41
42
43
44
45
46
47
48
49
50
51
52
53
54
55
56
57
58
59
60
61
62
63
64
65

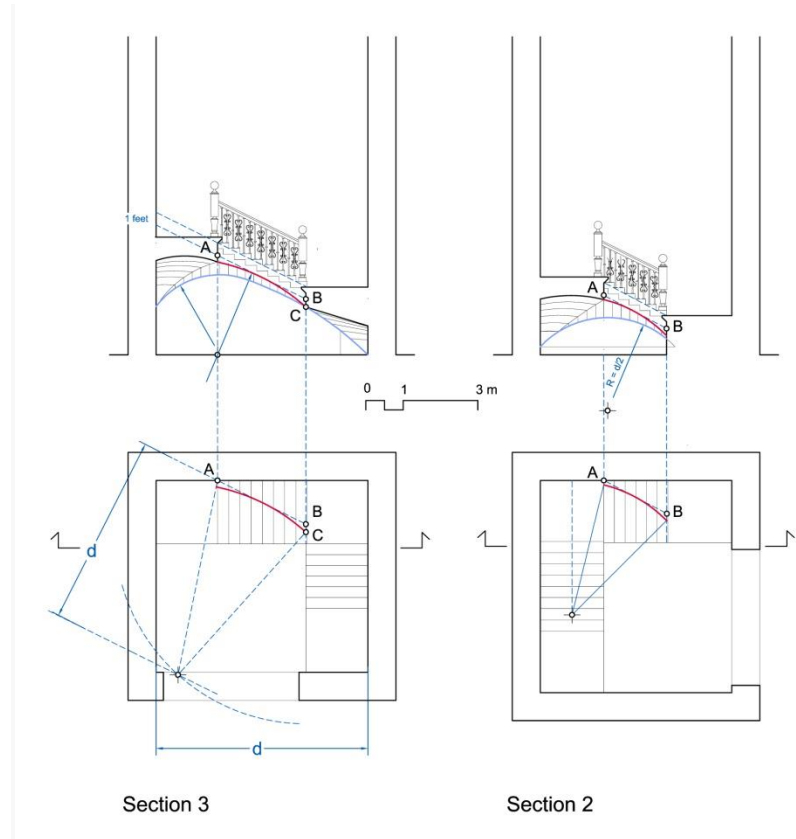

Figure 13: Tracing hypothesis of the *Aduana Real* stairway (Valencia). Drawing by the authors

Conclusions

The results obtained attest the existence of a geometric tracing method of these stairways' vaults not collected in the known treatise sources. The procedure is based on the use of references obtained from the stairwell dimensions for two reasons: they are easy to remember measurements and it allows drawing the geometric process on the floor of stairway's core.

It should be noted that the design of highly complex combined surfaces can be solved through a simple geometric procedure. By fixing some variables as starting data, all the curves of the voussoirs' edges are defined. These curves are the only reference that the stonemason has when warping the intrados surface. This last operation, therefore, does give rise to a remarkable difficulty (Marín and López 2018: 7).

The compelled visual continuity that should be given to these curves, extending them through the lower part of the following section vaults to reach the wall, justifies the definition of the pronounced curved splays so characteristic of these stairways, with the exception of the first section, where they are straight as this constraint is not present.

An important differentiating feature with regards to their courtyard predecessors, is that their trace was approached taking into consideration both the floor plan and the elevation of the element projections simultaneously, as established by modern descriptive geometry. Ultimate-

1
2
3
4 ly, the result expresses with unique elegance the maturity of the long-standing Valencian tradi-
5 tional masonry of the Modern Age, to which, at the same time, they served as an epilogue.
6
7

8 9 **Note**

10 This article is framed in the R&D project “Geographies of artistic mobility. Valencia in the Mod-
11 ern Age» (HAR 2017-83070-P), financed by the Ministry of Economy, Industry and Competi-
12 tiveness of the Government of Spain.
13
14

15 16 **Referencias**

17 Almagro Gorbea, Antonio. 2019. Half a century documenting the architectural heritage with
18 photogrametry. *EGE Revista de expresion gráfica en la edificación*.
19 <https://doi.org/10.4995/ega.2019.12863>
20

21 Benito Domenech, Fernando. 1981. *La arquitectura del Colegio del Patriarca y sus artífices*.
22 Valencia: Federico Domenech.
23

24 Bérchez Gómez, Joaquín. 1987. *Los comienzos de la arquitectura académica en Valencia:*
25 *Antonio Gilabert*. Valencia: Alfons el Magnànim.
26

27 Bérchez Gómez, Joaquín. 1993. *Arquitectura Barroca valenciana*. Valencia: Bancaja.

28 Equizzi, Giulia. 2019. *La escalera de patio del palacio de En Bou de Valencia: traza, construc-*
29 *ción y estructura*. Trabajo Fin de Máster. Universitat Politècnica de València.
30

31 Falomir Faus, Miguel. 1996. *Arte en Valencia, 1472-1522*. Valencia: Consell Valencià de Cultu-
32 ra.
33

34 Gelabert, Joseph. 1653. Ed. de Enrique Rabasa. 2011. *Vertaderas traçes del Art de picape-*
35 *drer*. Mallorca: Col·legi Oficial d'Arquitectes de les Illes Balears.
36

37 Gómez-Ferrer Lozano, Mercedes y Joan Corbalán de Celis. 2004. *La casa del obispo de Tor-*
38 *tosa, Alfonso de Aragón. Un palacio valenciano en la encrucijada entre dos siglos (XV-XVI)*.
39 *Ars Longa* 13: 11-31.
40

41 Gómez-Ferrer Lozano, Mercedes. 2005. Patios y escaleras en los palacios valencianos del
42 siglo XV. En *Historia de la Ciudad IV*, 121-134. Valencia: Colegio Territorial de Arquitectos.
43

44 Huerta, Santiago. 2007. Oval Domes: History, Geometry and Mechanics. *Nexus Network Jour-*
45 *nal* 9, 2: 211-248.
46

47 López González, Concepción y Rafael Marín Sánchez. 2019. La escalera imperial del Real
48 Monasterio de San Miguel de los Reyes de Valencia (1601-1603): hipótesis de traza. *Revista*
49 *EGA*. <https://doi.org/10.4995/ega.2019.10552>
50

51 Marín Sánchez, Rafael. López González, Concepción. 2018. La escalera del Real Colegio
52 Seminario de Corpus Christi de Valencia (1599-1601): hipótesis de traza. *Informes de la Cons-*
53 *trucción*. <https://doi.org/10.3989/id.59131>
54

55 Navarro Camallonga, Pablo y Enrique Rabasa Díaz. 2018. Bóvedas construidas como arcos
56 en la arquitectura de Baldomar. *Revista EGA*. <https://doi.org/10.4995/ega.2018.8606>
57

58 Navarro Camallonga, Pablo. 2018. *Arcos, bóvedas de arista y bóvedas aristadas de cantería*
59 *en el círculo de Francesc Baldomar y Pere Compte*. Tesis doctoral. Universitat Politècnica de
60 València.
61

62 Pérouse de Montclos, Jean-Marie. 1982. *L'architecture à la française: du milieu du XVe siècle*
63 *à la fin du XVIIIe siècle*. París: Picard.
64
65

1
2
3
4 Portor y Castro, Juan de. 1708. *Cuaderno de Arquitectura* (manuscrito). Madrid: Biblioteca
5 Nacional. Mss. 9114.

6
7 Salcedo Galera, Macarena. 2017. *Construcción pétreo en la Granada del Renacimiento*. Tesis
8 doctoral. Universidad Politécnica de Cartagena.

9
10 Spallone, Roberta. 2019. Geometry of vaulted systems in the treatises by Guarino Guarini.
11 *EGE Revista de expresion gráfica en la edificación*. <https://doi.org/10.4995/ege.2019.12872>

12
13 Tosca, Thomas Vicente. 1727. *Tratado de la Montea y Cortes de Cantería*. Segunda impre-
14 sión. Madrid: Imprenta de Antonio Marín.

15
16 Vandelvira, Alonso de. 1575-1591 [1646]. *Fragmentos de dibuxos y discursos de arquitectura*
17 *[manuscrito] de Alonso de Vande Elvira*; copiados ordenados acaso por Felipe Lázaro de Goiti.
18 Madrid: Biblioteca Nacional. Mss. 12.719.

19
20 Zaragoza Catalán, Arturo, José Calvo López y Pau Natividad Vivó. 2012. Stereotomic Ex-
21 changes between Iberia and France in the 16th Century: Benoît Augier, Valencian Stairways
22 and the Escalier de Toulouse. En *Proceedings of the Fourth International Congress on Con-
23 struction History 1*: 385–392. Paris: Picard.

24
25 Zaragoza Catalán, Arturo. 2010. Cuando la arista gobierna el aparejo: bóvedas aristadas. En
26 *Arquitectura en construcción en Europa en época medieval y moderna, 187-224*. Valencia:
27 Universitat de València.

28
29 Zaragoza Catalán, Arturo. 2013. Las escaleras con bóveda continua de piedra: técnicas y sig-
30 nificados. El episodio valenciano de la edad moderna. En *Le scale in pietra a vista nel Medite-
31 rraneo*, 21-36. Palermo: Caracol.

32
33 Zaragoza, Arturo, Rafael Marín y Pablo Navarro. 2019. *Juegos Matemáticos en el Palacio de*
34 *la Generalitat Valenciana*. Valencia: Presidència de la Generalitat.

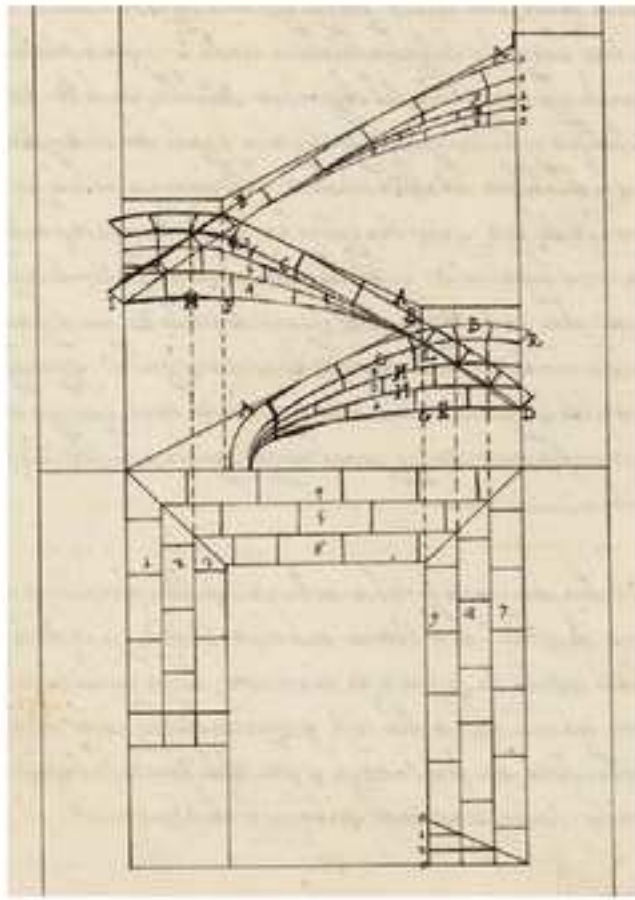

a

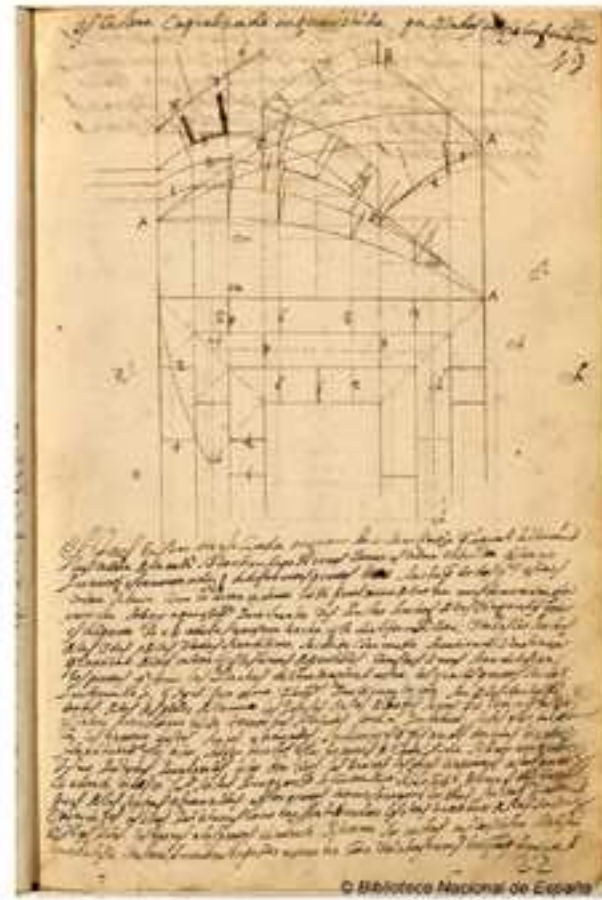

b

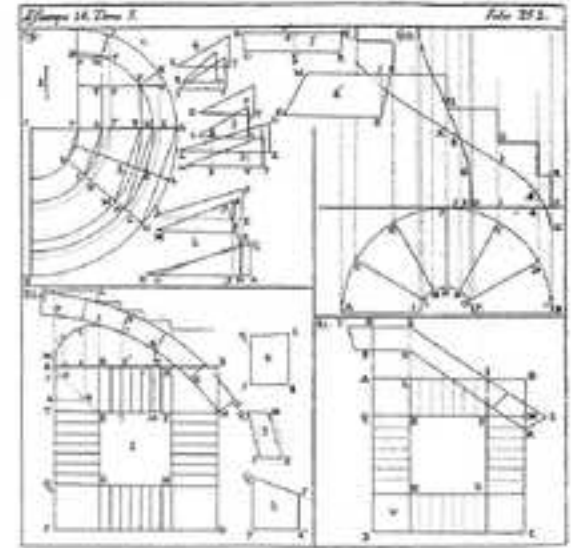

c

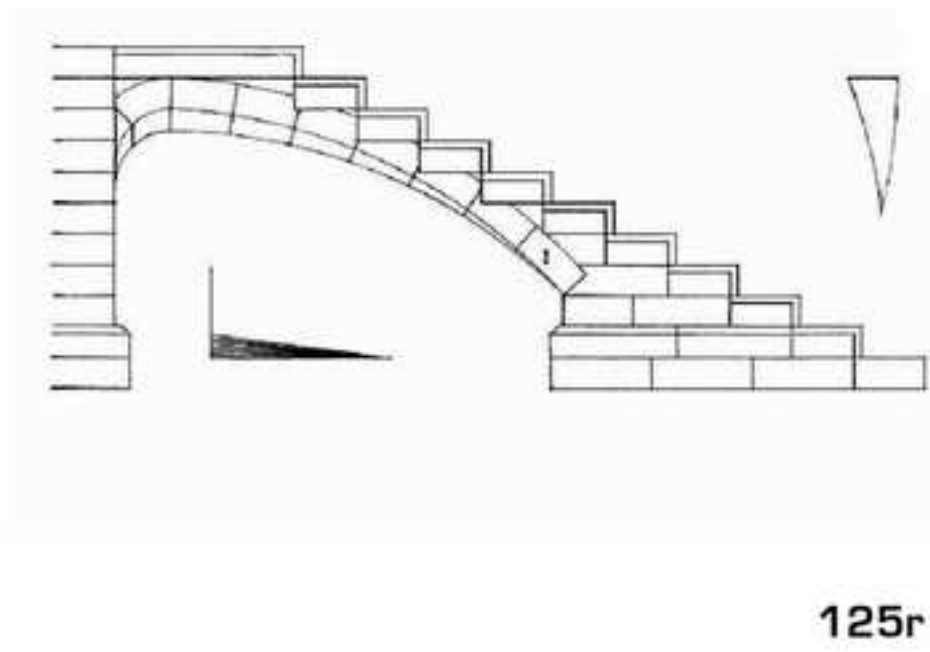
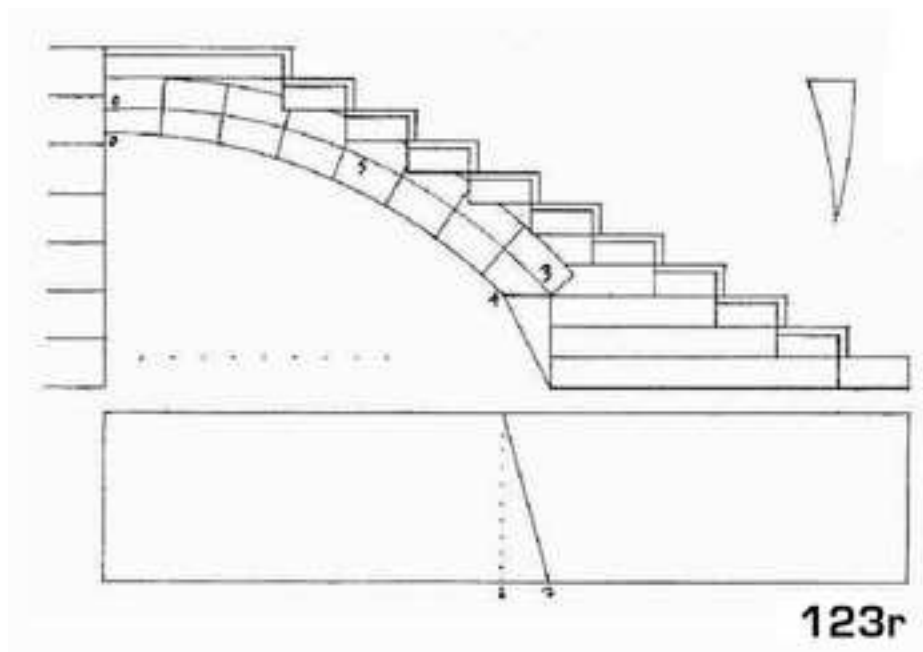





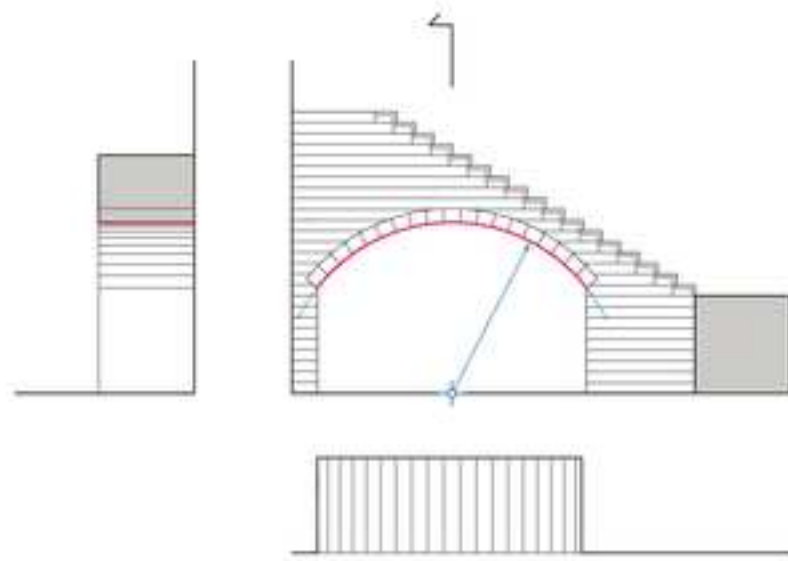
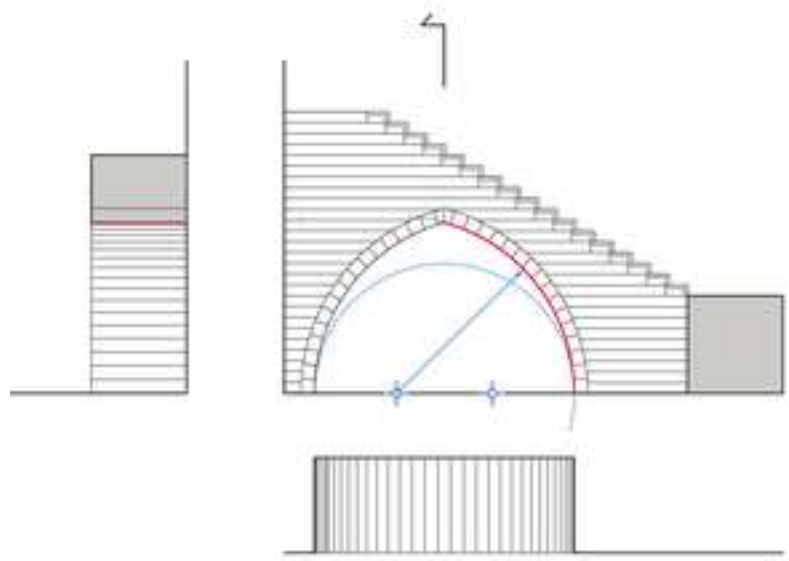
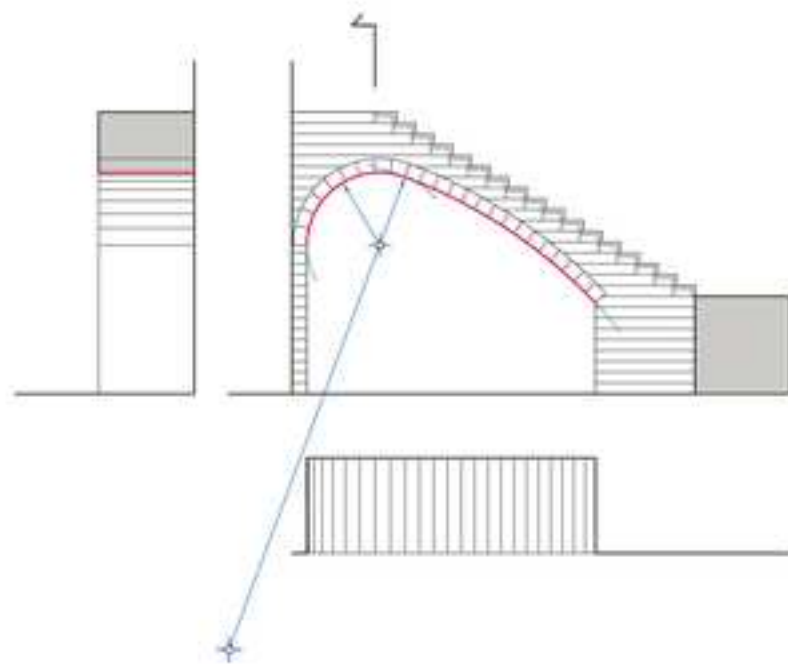
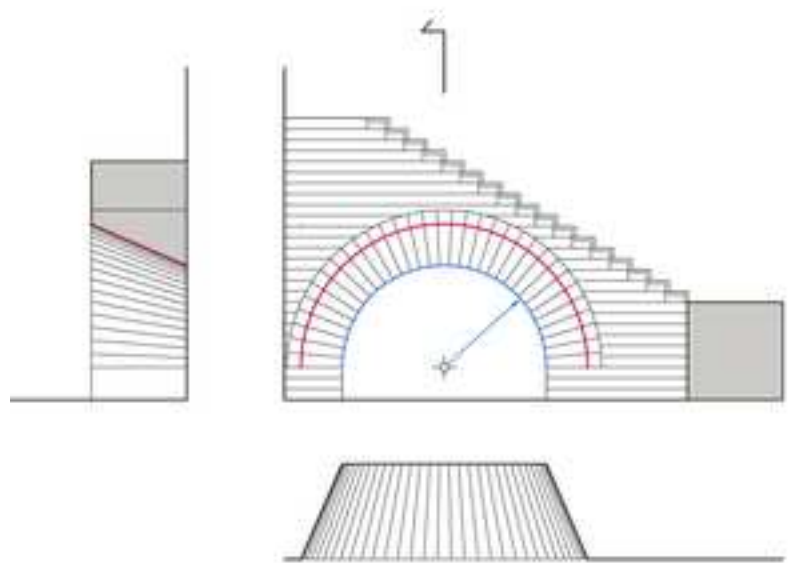

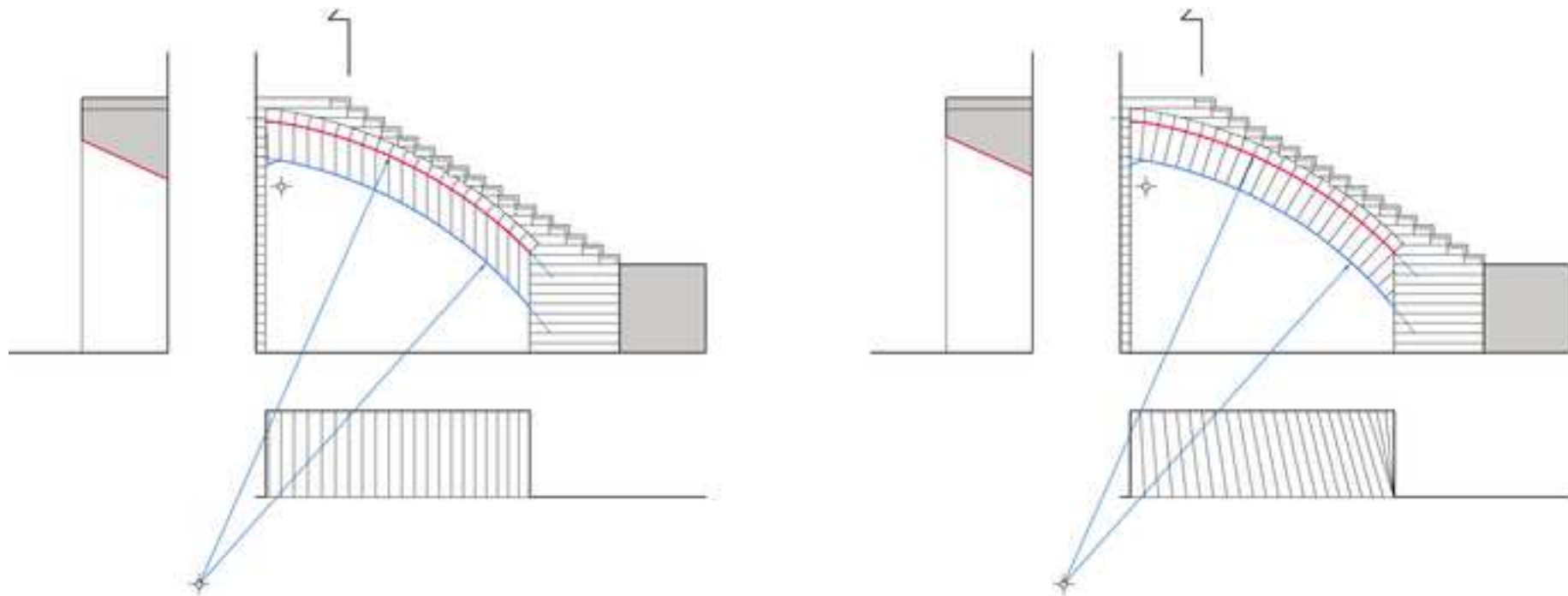

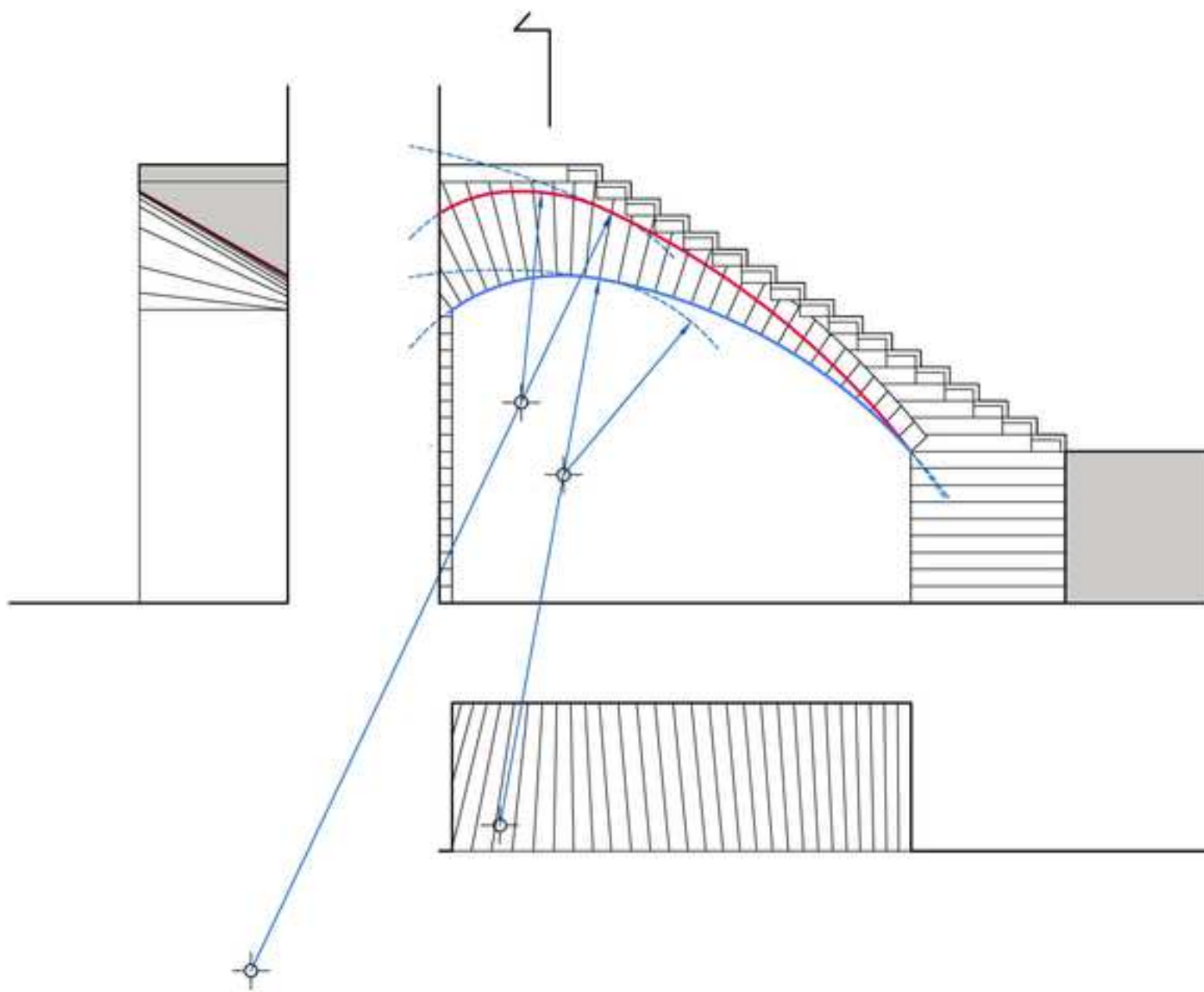

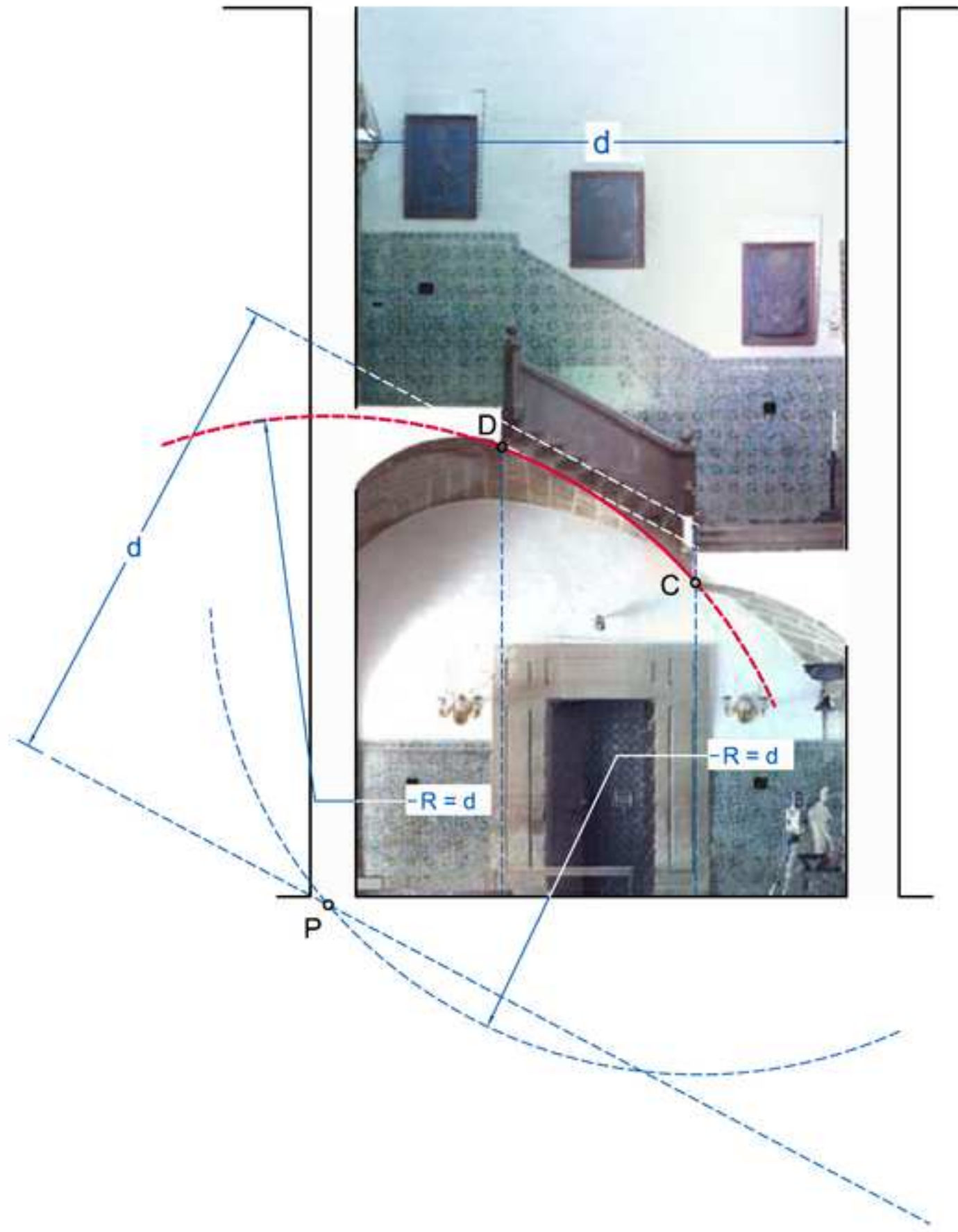

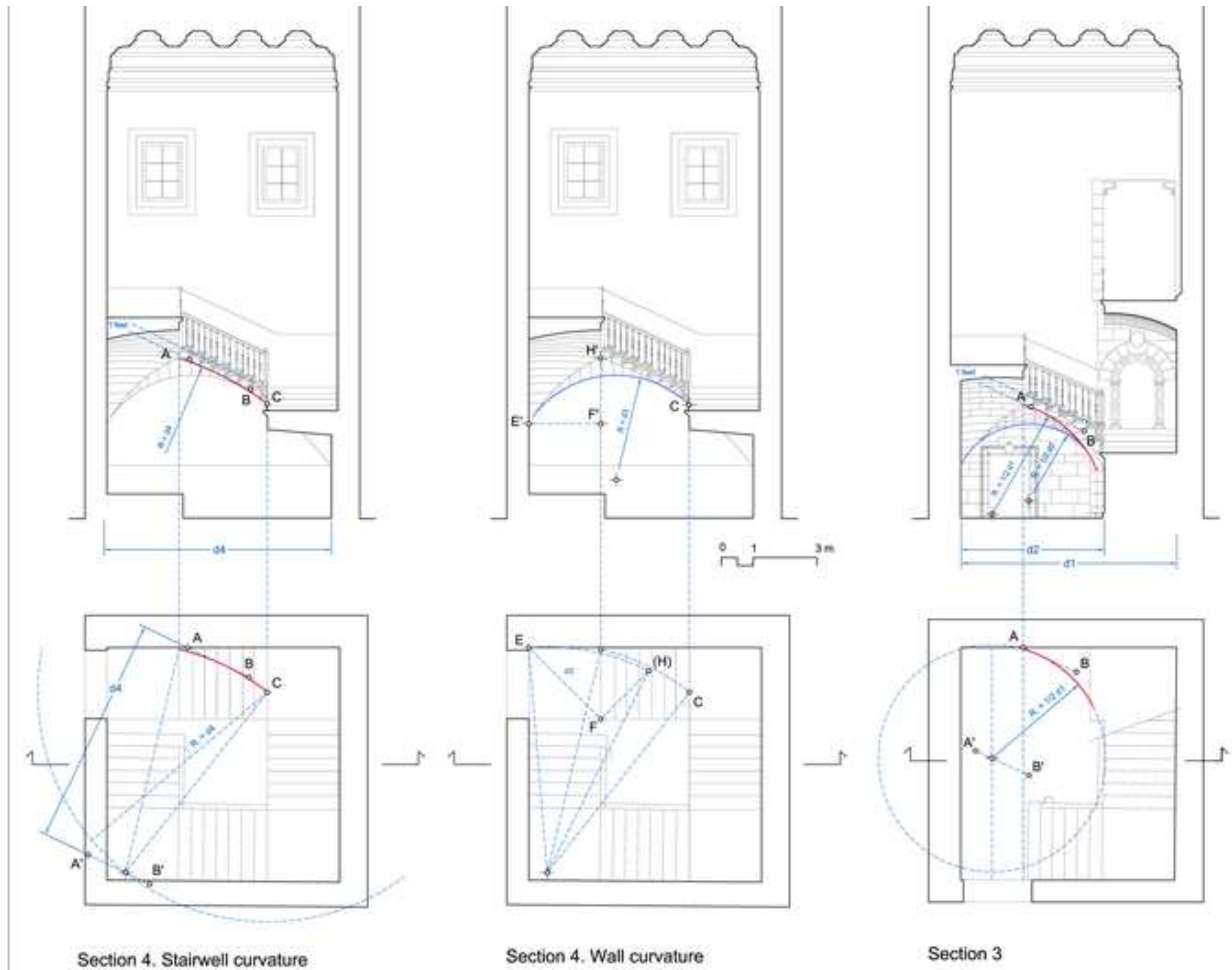

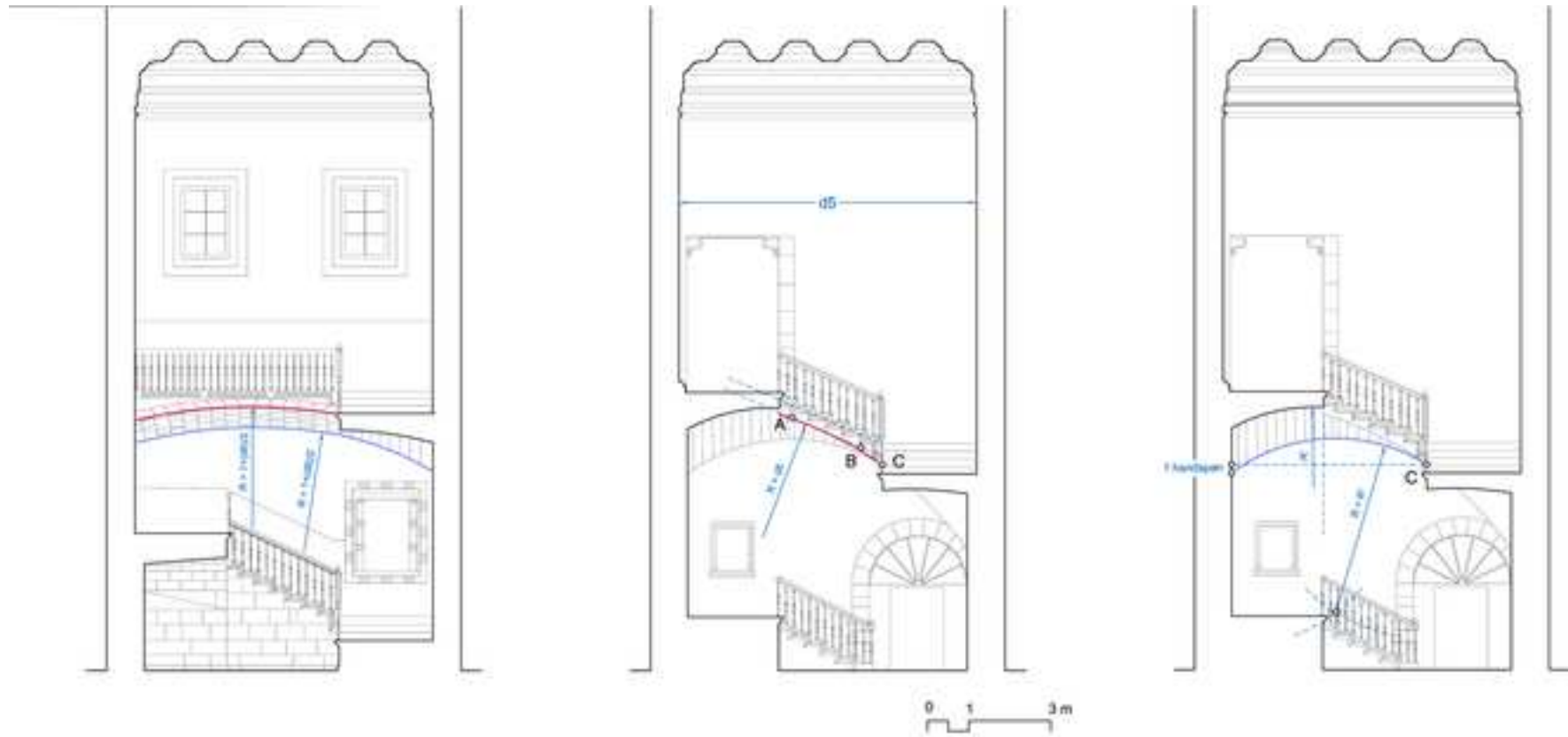

Section 6

Section 5. Wall curvature

Section 5. Stairwell curvature

