



VILNIUS GEDIMINAS TECHNICAL
UNIVERSITY

FACULTY OF CIVIL ENGINEERING

DEPARTMENT OF CONSTRUCTION TECHNOLOGY

AND MANAGEMENT

Administracinio pastato T. Narbuto g. Vilniuje statybos projektavimas
Construction design of administrative building at 35 T. Narbuto str. in
Vilnius

Alumn: Borja, Estellés Casado

Supervisor: Jonas Saparauskas

Language - English



VILNIUS GEDIMINAS TECHNICAL UNIVERSITY

FACULTY OF CIVIL ENGINEERING

DEPARTMENT OF CONSTRUCTION TECHNOLOGY AND
MANAGEMENT



APPROVED:
Head of Department:

Edmundas K. Zavadskas
Data:

Borja Estellés Casado

Administracinio pastato T. Narbuto g. Vilniuje statybos projektavimas
Construction design of administrative building at 35 T. Narbuto str. in
Vilnius.

Final thesis work

Supervisor: Dr. Jonas Saparauskas : _____ **data:**

Consultant: Linas Jucknevicius: _____ **data:**

Vilnius, 2012



ANNOTATION

The purpose of this final thesis is the design of construction of the “Administration building sited in T. Narbuto street nº 35 T in Vilnius”(New construction).

The final thesis work is divided in four parts:

1) ARCHITECTURAL PART: This part consist of a little description of the building desing and drawings. This drawings show the facades. The horizontal/vertical sections and the situation map of the building.

2) STRUCTURAL PART:

2.1 A little description of the structural elements.

2.2 Desing and calculation of the stairs. The calculations are made by hand (SPANISH NORMATIVE - EHE).

3) TECHNOLOGICAL PART: This part consist in the technological description of two works.

-Slab structure installation in second floor.

-Curtain wall installation. General process.

4) ORGANIZATION PART. Schedules of the works, workers and machinery.

This final thesis work consist of:

Handwritting description: 78 pages.

Graphical part: 6 plans.

1. ARCHITECTURAL PART	6
1. 1. DESCRIPTIVE MEMORY	6
1.1.1 INTRODUCTION	6
1.1.2 LOCATION	6
1.1.3 FIELD	8
1.1.4 DISTRIBUTION FLOORS	8
1.2. CONSTRUCTIVE MEMORY	9
1.2.1 DESCRIPTION OF STRUCTURE.....	9
1.2.2 FOUNDATION	10
1.2.3 COLUMNS	12
1.2.4 SLABS	12
1.2.5 STAIRS	13
1.2.6 FLOORS	13
1.2.7 FACADE	14
1.2.8 INTERNAL PARTITIONS	14
1.2.9 INSTALLATIONS	14
1.2.9 FIRE SAFETY	14
1.2.11 HEALTH CONDITIONS	14
1.2.12 ENVIRONMENT	14
1.2.13 DISABILITY NEEDS	14
1.2.14 LIFT AND MACHINERY	14
2. CONSTRUCTIONAL PART	15
2.1 DESIGN OF STAIRS SYSTEM	16
2.1.1 DESIGN OF FORM	16
2.2 INSTRODUCTION	16
2.1.2 CHARACTERISTICS OF THE MATERIALS	16
2.2 CALCULATION	17
3. TECHNOLOGICAL CARDS	23
3.1 TECHNOLOGICAL CARD OF SLAB STRUCTURE INSTALLATION.....	23
3.1.1 GENERAL DESCRIPTION	23
3.1.2 DESCRIPTION OF TECHNOLOGY WORKS.....	23
3.1.3 INSTALLATION SEQUENCE. FROM 1 TO 3	27
3.1.4 HUMAN SAFETY	29
3.1.5 MATERIAL – TECHNICAL RESOURCES	29
3.1.6 QUALITY CONTROL	32
3.1.7 SOME DETAILS	33
3.1.8 CALCULATION OF QUANTITY OF WORKS AND PRICE	34
3.1.9 TECHNICAL - ECONOMIC INDICATORS	34



3.2 CURTAIN WALL INSTALLATION- TECHNOLOGICAL CARD.....35

3.2.1 GENERAL 35

3.2.2 DESCRIPTION AND CONSTRUCTION SEQUENCE 37

3.2.3 INSTALLATION SEQUENCE.39

3.2.4 HUMAN SAFETY 43

3.2.5 MATERIAL – TECHNICAL RESOURCES 43

3.2.6 QUALITY CONTROL 44

3.2.7 SOME DETAILS 45

3.2.8 CALCULATION OF QUANTITY OF WORKS AND PRICE 46

3.2.10 TECHNICAL - ECONOMIC INDICATORS46

4. ORGANIZATION PART 47

4.1 DESCRIPTION OF TERRITORY 47

4.1.1 SELECTION OF TOWER CRANE 48

4.1.2 SETTING OF DANGEROUS ZONE 52

4.1.3 TEMPORARY STORAGE BUILDINGS AND SITES 58

4.1.4 TEMPORARY BUILDINGS FOR WORKERS AND MANAGING ...58

4.1.5 TEMPORARY ELECTRICITY SUPPLY58

4.1.6 CONSTRUCTION SITE LIGHTNING60

4.1.7 TEMPORARY WATER SUPPLY 61

4.1.8 TEMPORARY SEWERAGE 61

4.1.9 FENCE OF CONSTRUCTION SITE 62

4.1.10 GENERAL REQUERIMENTS OF LABOR SAFETY 63

4.1.14 REQUIREMENTS OF ENVIRONMENTAL PROTECTION64

4.1.15 REQUIREMENTS OF FIRE PROTECTION.....65

4.2.2 WORKFORCE 65

4.2.1 DISTRIBUTION WORKFORCE..... 65

4.2.2 MACHINERY 66

BIBLIOGRAPHY 67

1.ARCHITECTURAL PART

1.1 DESCRIPTIVE MEMORY

1.1.1 INTRODUCTION:

The final thesis work will consist in the constructive description of administration building in Vilnius(Lithuania). This building is sited in T. Narbuto street n° 35. The shape of the building is modern and innovative. The building has trapezoid shaped and its plant is reduced when the building increases in height. The building has 2 underground floors and 7 floors above ground. All the floors are office rooms. Communicates vertically by stairs enclosed in a reinforced concrete box that provides stability to the whole. It includes two elevators.The closings consist in curtain wall (main facades) and ventilated facades with ceramic plates. The project building is made with Spanish standars.

SURFACE:

-Building area: 4118.25m²

1.1.2 LOCATION:

This Building is located in Narbuto street and Pilaites street . Number 35. In Vilnius (Lithuania). Aerial view (*IMAGE 1*) and two 3D view (*IMAGE 2*, *IMAGE 3*) show the location of the building and its surroundings.

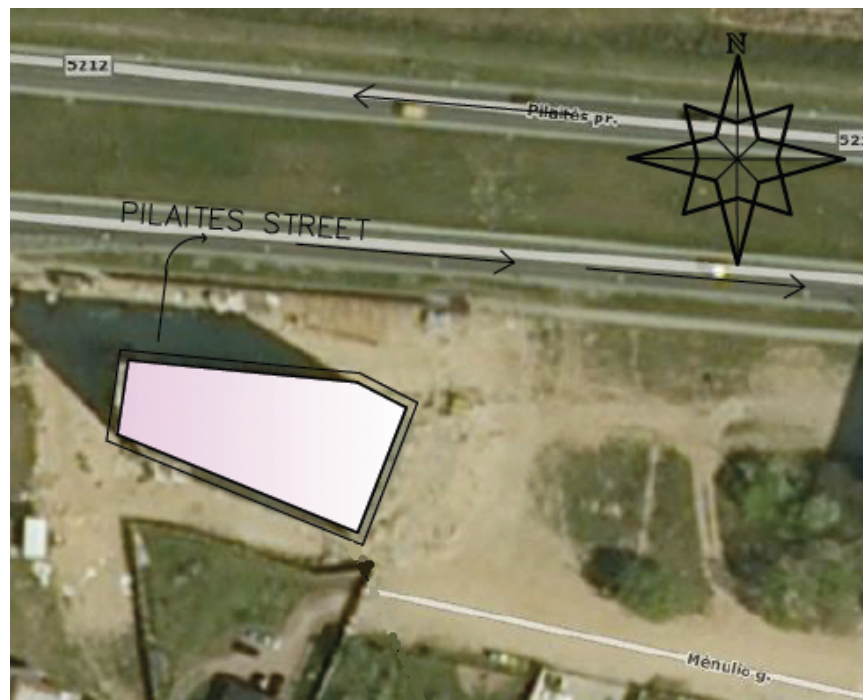

IMAGE 1. Aerial view of building location.



IMAGE 2 AND IMAGE 3. Final view of the construction.



1.1.3 FIELD:

The area of the building is 4118.25m² forming one irregular polygon like one trapezoid. There aren't constructions near of our building and in the south facade we can find the Pilaites street and in the north we can find Menulio street (*IMAGE 1*).

Pilaites street will be the main acces for the machinery, and when the construction will be finished it will be the acces for the cars to the parking.

1.1.4 DISTRUBUTION FLOORS:

The shape of the building is modern and innovative. There are two undergrounds floor wich function will be parking of private cars the parking surface will be 1450m². The ground floor consist in a big hall with 8 offices room and 2 toilets and bathrooms.

From te second to the 6 floor the building present more or less the same distribution but the surface decrease with the highh. In these floors the distribution is more or less according to the image (*TABLE 1*).

The sufaces decrease in order to:

Second floor 528.12 m²

Third floor 477.06 m²

Fourth floor 432.57 m²

Fifth floor 383.85 m²

Sixth floor 341.76 m²

Seventh floor * 102.44 m²

*Seventh floor its the smallest we can find the terrace and instalation/storage rooms.

SECOND FLOOR LEGEND		
SYMBOLISM	DESCRIPTION	AREA
1)SINGLE ROOM:		
001	ELEVATOR HALL	13,06
002	STAIRCASE	
003	STAIRCASE	
004	LOBBY	4.36
005	LANDING	2.82
TOTAL		20.24
2)OFFICE A:		
006	RECEPTION	84.8
007	TOILET	3.75
008	BATHROOM	3.75
009	WORK ROOM	19.87
010	STORAGE ROOM	5.36
011	KITCHEN	8.9
012	REST ROOM	14.62
013	WORK ROOM	10.85
014	REST ROOM	10.85
015	DIRECTOR CABINET	10.85
016	WORK ROOM	22.09
TOTAL		195.63
3)OFFICE B:		
017	RECEPTION	34.07
018	CORRIDOR	24.04
019	TOILET	3.14
020	BATHROOM	3.14
021	KITCHEN	16.74
022	WORK ROOM	12.37
023	MEETING ROOM	12.37
024	REST ROOM	12.37
025	DIRECTOR CABINET	12.37
026	CORRIDOR	3.36
027	WORK ROOM	8.83
028	WORK ROOM	22.33
TOTAL		165.13
4)OFFICE C:		
029	RECEPTION	34.62
030	CORRIDOR	14.06
031	TOILET	2.93
032	BARTHROOM	2.93
033	WORK ROOM	26.68
034	WORK ROOM	11.62
035	WORK ROOM	11.62
036	WORK ROOM	23.38
037	KITCHEN	7.3
038	MEETING ROOM	11.98
TOTAL		147.12
TOTAL FLOOR		528.12

TABLE 1. *Distribution of second floor.*

1.2. CONSTRUCTIVE MEMORY

1.2.1 DESCRIPTION OF STRUCTURE:

-The dimensions of the building plan:

A) PART OF THE UNDERGROUND=51.4 x 21.9 m

B) PART OF THE GROUND=41.8 x21. 9 m

Building underground is divided into two blocks of feedwater temperature. Also, high-rise building is separated from the parking expansion joints. The maximum height of the administrative building suplaniruoto ground level to ≈ 26.2 m, average height of 3600 mm high. Underground parking lots of high average height - 3000 mm.

-Administrative building a support frame type:

- Drilled solid foundations.
- Monolithic columns.
- Monolithic ceilings and roofing.

1.2.1.1 MATERIAL CONSTRUCTIONS:

Building the ground segment of the inner concrete reinforced concrete not less than C25/30 strength class according to DIN EN 206-1.

Building ground segment of the outer concrete structures (directly exposed to atmospheric effects) not less than the concrete strength C30/37 class according to DIN EN 206-1.

Underground parts of buildings of reinforced concrete columns, walls, beams lower than C25/30 strength class according to BS EN 206-1.

Construction of parking ramps concrete floor no lower than C30/37 strength class according to BS EN 206-1. Concrete foundation not less than C20/25 strength class according to DIN EN 206-1.

Internal structures used in the terrestrial water permeability of concrete and frost resistance characteristics must meet the requirements for concrete used in the XC1 class environmental conditions, external ground structures must meet the requirements for concrete used in the class XF4 environmental conditions, and the construction of an underground concrete used.

The requirements for concrete used in the XC2 class environmental conditions in accordance with BS EN 206-1.

Reinforced concrete structures, the longitudinal and transverse reinforcement

Working Class S400b reinforcement welded connection board method, and cross-class S240 - knotted. General guidelines for the installation of reinforced concrete structures and the production of drawings SK, SK-1 sheet and technical specifications. Note: all of the supporting frame structures can be produced and installed only in accordance with the building design of the revised working draft of the solutions.

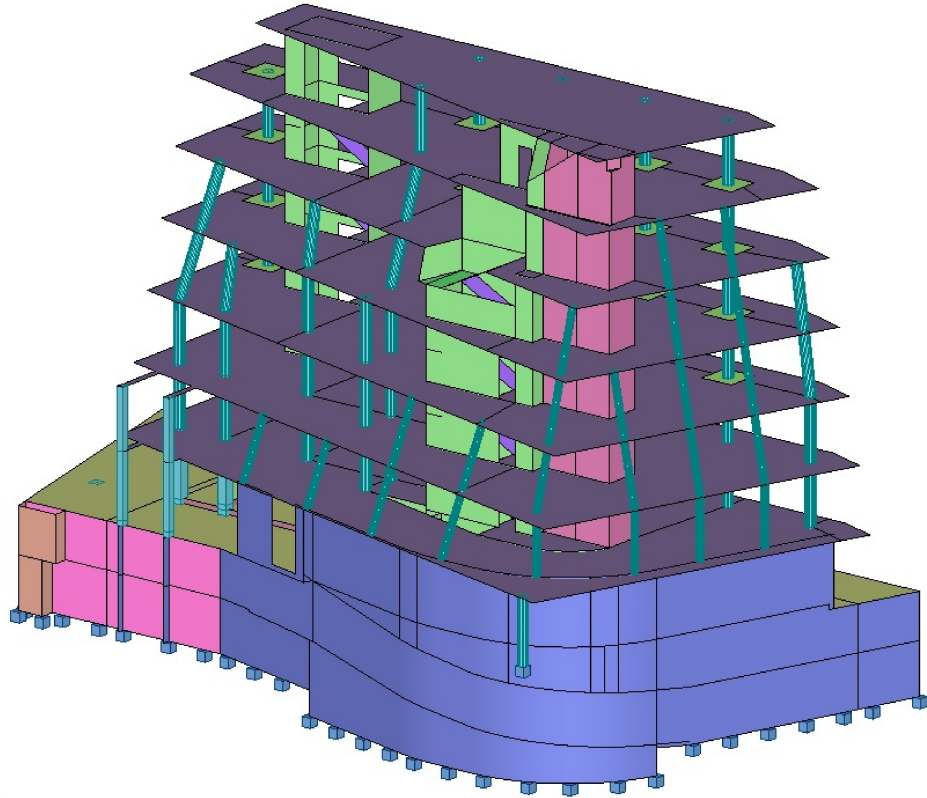

1.2.2 FOUNDATIONS:

The type of foundation chosen: Footings, piles on two pile cap.

b The pile driving or system, is a type of point-type deep foundation, which is driven into the ground always looking for the resistant layer capable of withstanding the loads transmitted. At the top of the pile cap pile is performed. the union of two piles to work together. (IMAGE4, IMAGE5).

- Concrete type HA-25
- Characteristic resistance $f_{ck} = 25 \text{ MPa}$
- Deduction coefficient of concrete:
- Specific weight of reinforced concrete $\gamma_H = 2.5 \text{ T/m}^3$
- Coating $d' = 5 \text{ cm}$
- Type of iron in the armors B400S
- Characteristic resistance of iron $f_{yk} = 500 \text{ MPa}$

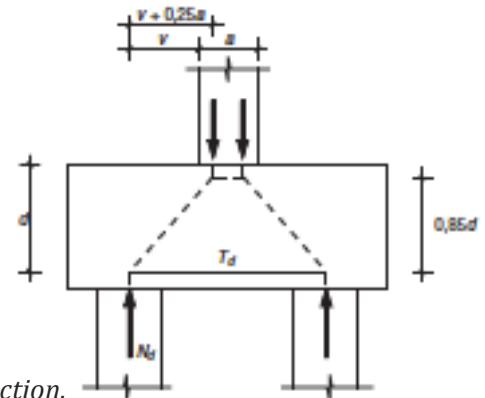

IMAGE 4. Loads direction.

After the monolithic columns and load bearing walls, foundation provides top altitude 200 .. 350 mm below the bottom of the building floor level. Do not hold the ground floor wall for support on the ground floor of the structure. Foundations for drilled, but the foundation type can be modified to reflect the potential economic effect.

IMAGE 5. Footing connexion.

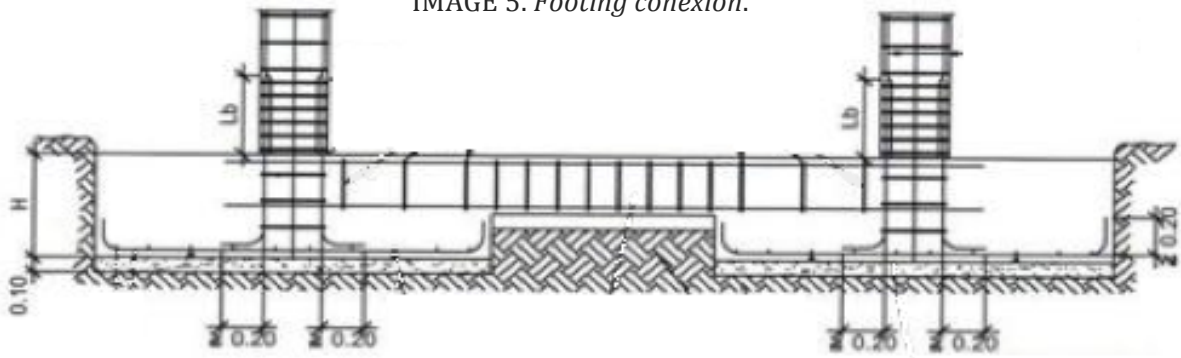
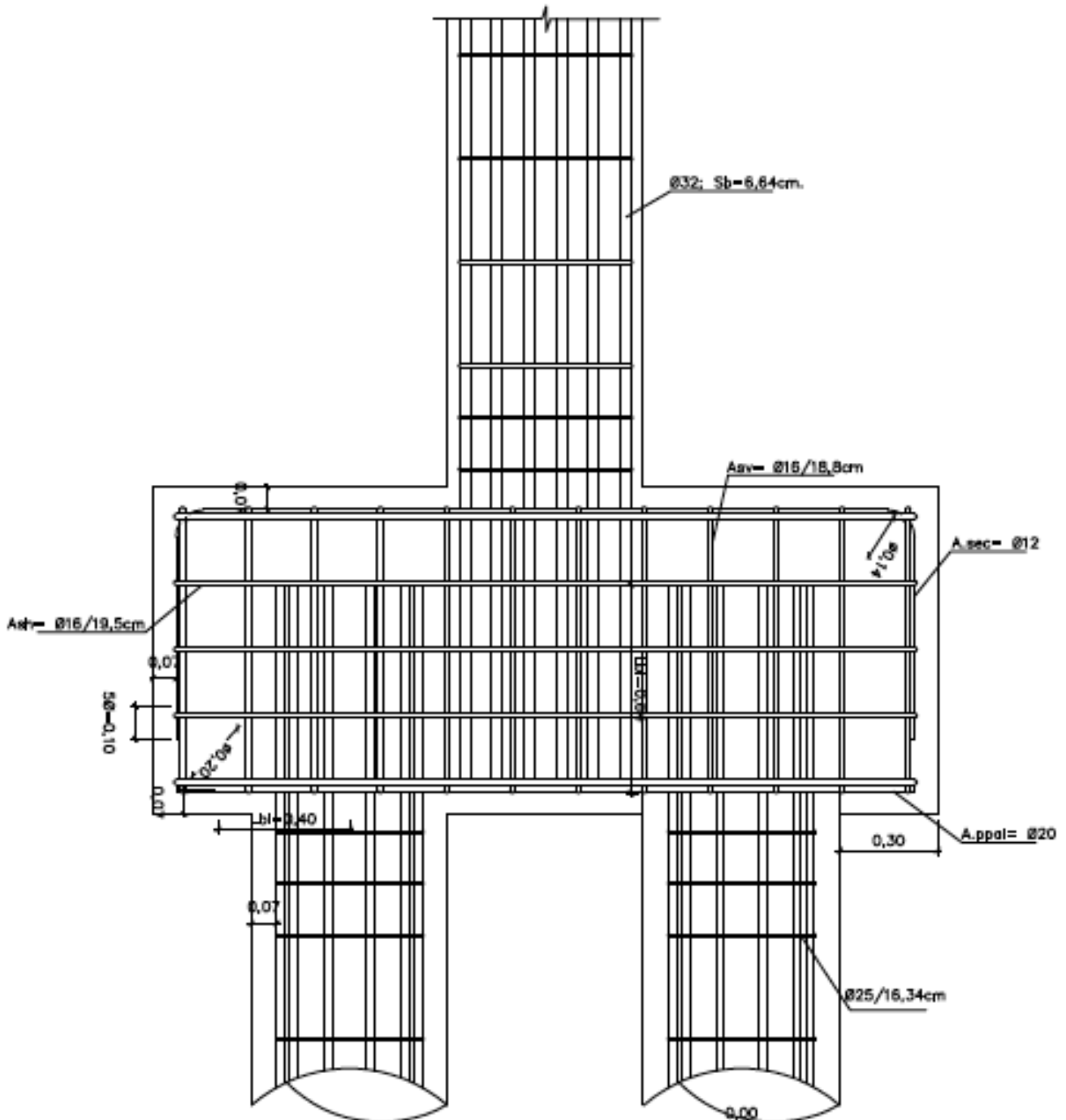

Image 5. Foundation reinforcement.



1.2.3 COLUMNS

The horizontal elements of the structure is reinforced concrete pillars round and square. This elements will be done according to EHE-08 normative.
The distances between the columns of the building to - 5.6-7.6 m.

Characteristic resistance $f_{ck}= 25$ MPa

Deduction coefficient of concrete:

Specific weight of reinforced concrete $\gamma_H= 2.5$ T/m³

Coating $d'= 5$ cm

Type of iron in the armors B400S

Characteristic resistance of iron $f_{yk}= 500$ MPa

Basic monolithic round 600mm and 400 mm in diameter (*IMAGE 6*). And a square 600x600mm and 400x400 mm. (*IMAGE 7*).

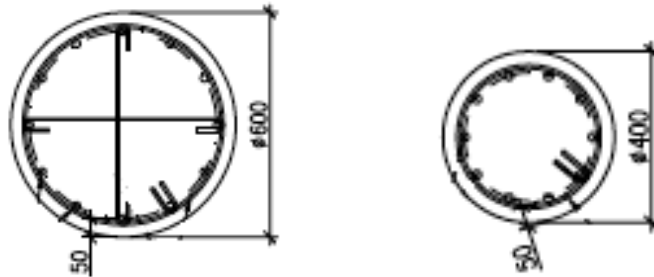

IMAGE 6. Round columns 600mm and 400mm.

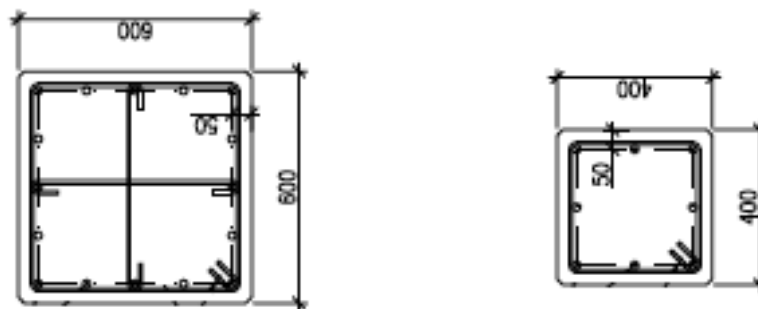

IMAGE 7. Square columns 600mm and 400mm.

1.2.4 SLABS

·DESCRIPTION: Monolithic reinforced concrete slab; concrete HA-25 ; steel B400S.

FLOOR 1: Monolithic reinforced concrete. Hight 250mm

FLOOR 2 to 7 and ROOF: Monolithic reinforced concrete. Hight 220mm

· Constructive reinforced overlays the (lower and upper) valve $\varnothing 12S500/220$ / $\varnothing 12S500/220$ networks and additional reinforcement to increase net stress areas(*IMAGE 8*).

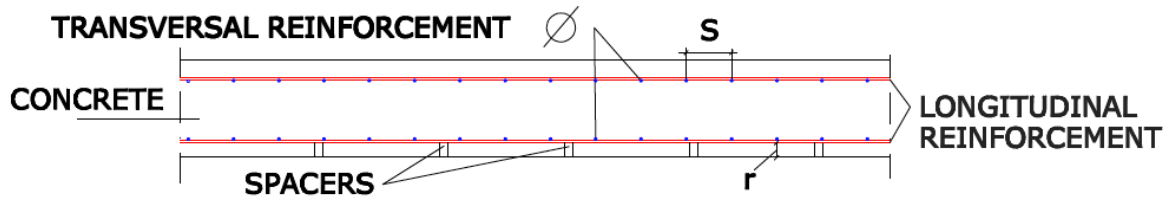

IMAGE 8. Slab section.

· In areas where floors cantilever is longer than 2.0 m. fitted with 2000x2000 mm dimensions capitals on the columns. (*IMAGE 9*).

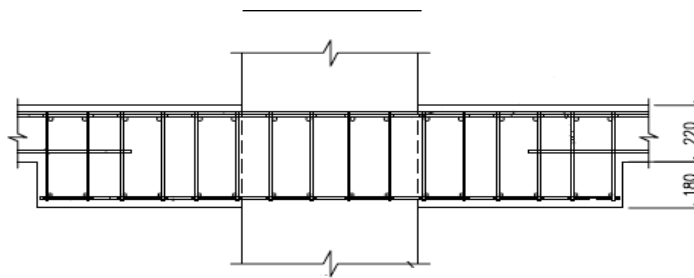

IMAGE 9. Capital detail.

1.2.5 STAIRCASE CONSTRUCTION

Staircases and landings bearing walls monolithic. Stairs are prefabricated.

1.2.6 FLOORS ON THE GROUND

On the ground floor of the principal component SK drawings. Floor temperature - expansion joints are installed every 6.0 m in both directions in and around the building columns (the foundation), incised floor layer holds a third of its thickness. Columns and floor joints installed in the intermediate areas. (*IMAGE10*).

IMAGE 10. Expansion joints detail

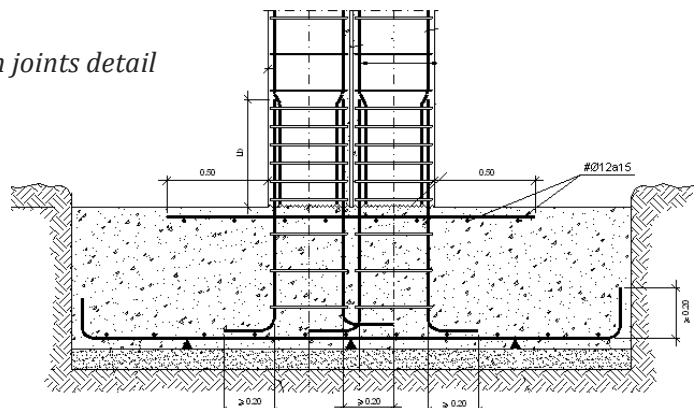

1.2.7 FACADE

The exterior walls of the building are determined by two types of Systems. These system are ventilated façade with ceramic plates and curtain wall. The curtain wall is constituted by a combination of elements of aluminum, a wide variety of glazing generally transparent and opaque areas.

1.2.8 INTERNAL WALLS AND PARTITIONS:

The partitions of our building will done plaster boards partitions walls have 10 cm of thickness; we will use this kind of partition except when we want to separate the bathrooms. In this case we will use porous expanded clay tiles walls with the same thickness. Porous expanded clay tiles Partitions between apartments 250 mm with two 10mm coating, one for each side. The last step is to paint.

1.2.9 INSTALLATIONS:

- Water supply and sewerage:

Projection of the building water supply facilities in the existing urban water supply networks. Domestic sewage water collected in plastic tubes and sewage discharged into urban sewage networks.

- Heating and ventilation:

Heating devices are radiators. Space for a natural ventilation system.

- Electricity:

Projected building is connected to an existing nearby transformer. Power consumption remains within the specifications issued

1.2.10 FIRE SAFETY:

In relation of the building will comply with all requirements of CTE (technical construction code) – Security Fire.

The facades, partitions and ceilings shall be fire resistant. Stairs design allows quick evacuation in case of fire.

1.2.11 HEALTH CONDITIONS:

In relation of health conditions building has been designed to meet all hygiene standards according to the CTE (Technical building code) - HS Health security.

1.2.12 ENVIRONMENT:

In Relation of environment. Domestic wastewater is led to the current urban sewerage networks and treatment plants in the city. During all the works, the needs of the environment will be satisfied, being one of the most important issue.

1.2.13 DISABILITY NEEDS:

The building is accessible for the disabled people, complying with all necessary regulations, being an excellent building for all of them.

1.2.14 LIFT AND MACHINERY:

The building has two different elevators, situated near. The maximum load of 1000 kg.

2. CONSTRUCTIONAL PART

In this part we will describe the stair system. It is one stair with two plateaus and the inclined slab. The calculations will be done by hand. In the Pictures we can see the dimensional characteristics.

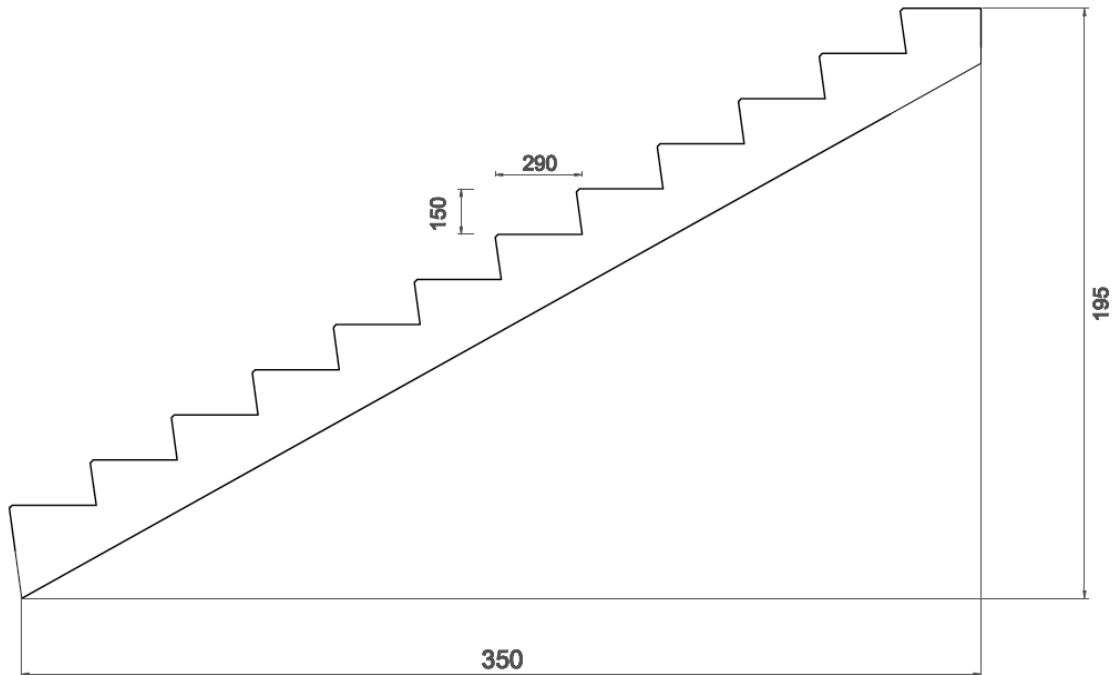

1) CALCULATION OF LOADS:

$$- Q_{ED} = (G + Q) = (7,2 \cdot 1,35 + 2 \cdot 1,30) \cdot 1,20 = \underline{14 \text{ kN/m}}$$

$$- G = (2500 \cdot 0,18 \cdot 1) + (2000 \cdot 0,05 \cdot 1) + (2500 \cdot 0,15/2);$$

$$G = 735,5 \text{ kg/m}^2 = 7,2 \text{ kN/m}^2$$

$$- Q = 2 \text{ kN/m}^2$$

2) CALCULATION OF M_{ed} and V_{ed} :

$$\cdot M_{ed} = Q_{ED} \cdot L^2 / 2 \cos \alpha = (14 \cdot 3,5^2) / 2 \cos 30 = 24,75 \text{ kN m}$$

$$\cdot V_{ed} = Q_{ED} \cdot L / 2 \cos \alpha = (14 \cdot 3,5) / 2 \cos 30 = 28,29 \text{ kN m}$$

TRANSVERSAL DIMENSIONS CACULATION:



- We consider $H_F = 100\text{mm}$ of thickness.
- Edge height $= 1/20 \cdot L = 3,5 / 20 = 0,175 \approx 18\text{cm}$
- $br = 1/2 h = 18/2 = 9 \text{ cm}$.

$$- b_{eff} = 2 (L/6) + b = 2 \cdot (350 / 6) + 18 = 134,67 \text{ cm}$$

OR

$$- b_{ef} = 12 \cdot h_f + b = 12 \cdot 10 + 18 = 138 \text{ cm}$$

·We will use the minimum value = 134 cm

SCHEME DESIGN:

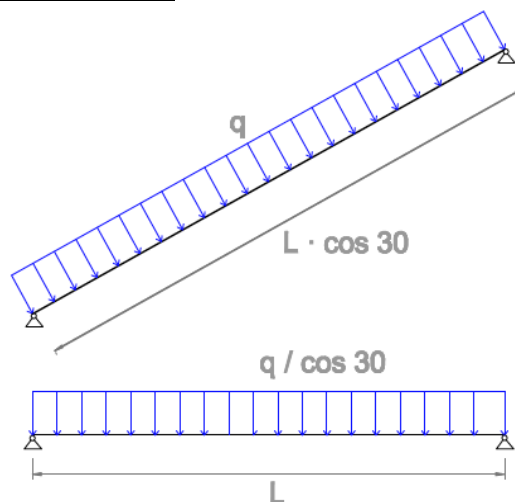

REASONABLE
CROSS-SECTION

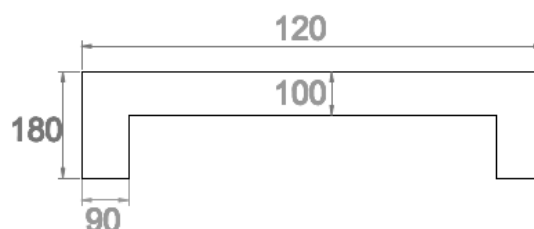

REDUCED
CROSS-SECTION B

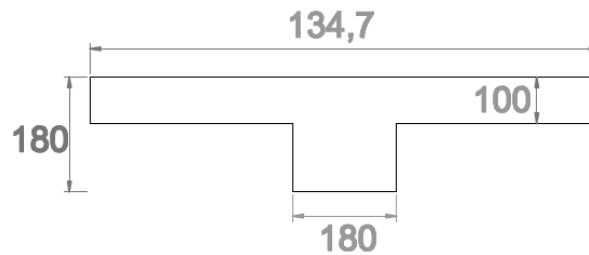

LONGITUDINAL REINFORCEMENT CALCULATIONS:

- Concrete compressive strength:

$$f_{cd} = \alpha_{cc} \cdot f_{ck} / \gamma_c = 0.9 \cdot (20/1,50) = 12 \text{ MPa}$$

- Reinforcement tensile strength:

$$f_{yd} = f_{yk} / \gamma_{cs} = 400/1,1 = 336,6 \text{ MPa}$$

-Relative compression zone, height limit:

$$\xi_{lim} = \frac{1}{1 + f_{yd} / (E_s \cdot \epsilon_{cuz})} = \frac{1}{1 + 363.6 / (200 \cdot 10^8 \cdot 0,0085)} = 0,0658$$

-Required reinforcement area:

$$M_f = \eta \cdot f_{cd} \cdot b_{eff} \cdot h_f \cdot \lambda \cdot (d - 0,5 \cdot h_f \cdot \lambda) = 1 \cdot 12 \cdot 10^3 \cdot 1,34 \cdot 0,10 \cdot 0,8 \cdot (0,17 - 0,5 \cdot 0,10 \cdot 0,8) = 167,23 \text{ kN} \geq M_{ed} = 24,75 \text{ kN m}$$

$$(- \lambda = 0,8 \quad - \eta = 1 \quad - d = 0,17)$$

$$\mu_{ed} = M_{ed} / \eta \cdot f_{cd} \cdot b_{eff} \cdot d^2 = 24,75 / 1 \cdot 12 \cdot 10^3 \cdot 1,34 \cdot 0,17^2 = 0,0532 M_{ed}$$

$$\xi = 1/\lambda (1 - \sqrt{1 - 2\mu_{ed}}) = 1/0,8 (1 - \sqrt{1 - 2 \cdot 0,0532}) = 0,068 < 0,658$$

Required area:

$$A_{s1} = \frac{\eta \cdot f_{cd} \cdot b_{eff} \cdot \lambda \cdot d \cdot \xi}{f_{yd}} = \frac{\eta \cdot f_{cd} \cdot b_{eff} \cdot d \cdot \xi \cdot \lambda}{f_{yd}} = \frac{1 \cdot 12 \cdot 10^3 \cdot 1'34 \cdot 0,17 \cdot 0,068 \cdot 0,8}{336,6 \cdot 10^3}$$
$$= 4,43 \cdot 10^{-4} = 4,43 \text{ cm}^2$$

Maximum reinforced points:

$$A_{smin} = 0,26 \cdot f_{ctm} / f_{yd} \cdot b_t \cdot d = 0,26 \cdot 1,5 / 400 \cdot 0,18 \cdot 0,17 = 2,98 \cdot 10^{-5} \text{ m}^2 \approx 0,298 \text{ cm}^2$$

· $A_{s1} 4,43 \text{ cm}^2 > A_{smin}$ (SATISFIES THE CONDITION)

$$A_{s1} = 2\emptyset 18 = 5,09 \text{ cm}^2$$

$$A_{s2} = 2\emptyset 10 = 0,785 \text{ cm}^2$$

TRANSVERSAL REINFORCEMENT CALCULATIONS:

· Transversal force: $V_{ED} = Q_{ed} \cdot L / 2 \cos \alpha = 14 \cdot 3,5 / 2 \cos 30 = 28'29 \text{ KN}$.

$$V_{ED} = V_{ed \max} - Q_{ED} \cdot R_1 = 28,29 - 14 \cdot 0,20 = 25,49 \text{ kN}$$

$$R_1 = a_1 + d = 0,03 + 0,17 = 0,20 \text{ m}$$

$$V_{rdc} = (C_{rcd} \cdot k \cdot (100 \cdot \rho_1 \cdot f_{ck})^{1/3}) \cdot B_w \cdot d =$$

$$= (0,12 \cdot 2 \cdot (100 \cdot 0'0075 \cdot 25)^{1/3}) \cdot 0,2 \cdot 0,17 = 0,0249 \text{ Mm} \approx 24,9 \text{ kN}$$

$$\cdot C_{rcd} = 0,18 / \gamma_c = 0,12 \quad \cdot k = 1 + \sqrt{200/d} = 1 + \sqrt{200/170} = 2,08 \geq 2 ; K = 2$$

$$\cdot \rho_1 = A_1 / (B_w \cdot d) = 2,55 \cdot 10^{-4} / (0,2 \cdot 0,17) = 0,0075 < 0,02$$

$$V_{rdc} = V_{min} \cdot B_w \cdot d = 0,47 \cdot 0,2 \cdot 0,17 = 0,016 \text{ Mn} \approx 16 \text{ kN}$$

$$V_{min} = 0,035 K^{3/2} \cdot f_{ck}^{1/2} = 0,47$$

$$V_{ED} = 28'29 \text{ KN} > V_{rdc} = 24,9 \text{ kN}$$

The condition is satisfied, and therefore does not calculate the transverse reinforcement.

$$A_{s3} = \emptyset 8 \text{ C}/200$$

Prefabricated concrete landings design:

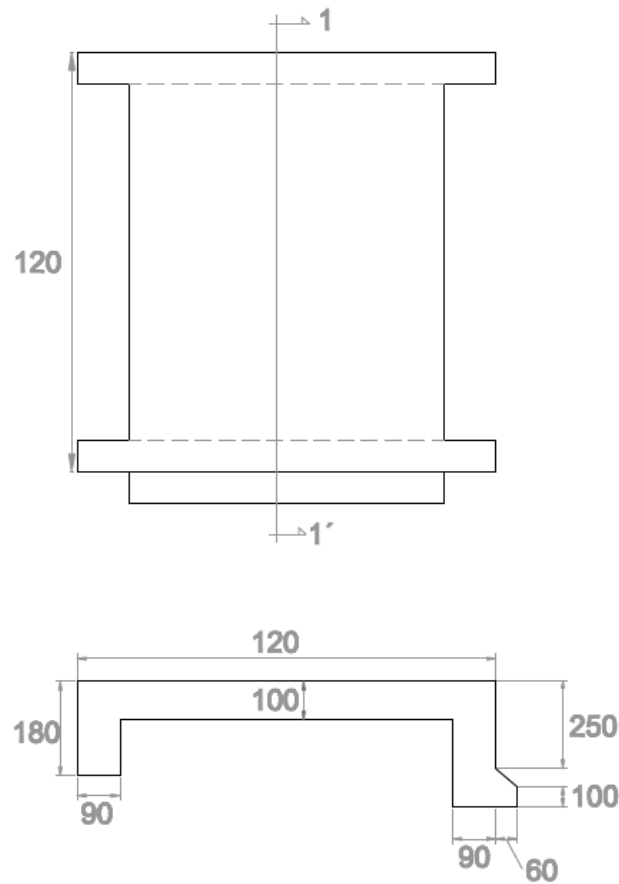

1) CALCULATION OF LOADS:

- $G_1 = 1 \cdot 2500 \cdot 9,8 = 2,4 \text{ KN} / \text{m}^2$
- $G_2 = 0,18 \cdot 0,09 \cdot 2500 \cdot 9,8 = 0,39 \text{ KN} / \text{m}^2$
- $G_3 = (0,09 + 0,35 + 0,06 + 100) 2500 \cdot 9,8 = 1,47 \text{ KN} / \text{m}^2$
- $q = (2 \cdot 1,47) = 2,94 \text{ KN} / \text{m}^2$

2) CALCULATION OF M_{ed} and V_{ed} :

• $M_{ed} = Q_{ED} \cdot L^2 / 16 = ((2,94 + 2,4) \cdot 1,02^2) / 16 = 0,35 \text{ kN m}$

$\mu_{ed} = M_{ed} / \eta \cdot f_{cd} \cdot b_{eff} \cdot d^2 = 0,35 / 1 \cdot 12 \cdot 10^3 \cdot 1 \cdot 0,08^2 = 0,0045$

• $b = 1 \quad \cdot d = 10 - 2 = 8 \text{ cm}$

$\xi = 1/\lambda (1 - \sqrt{1 - 2\mu_{ed}}) = 1/0,8 (1 - \sqrt{1 - 2 \cdot 0,0045}) = 0,0056 < \xi_{lim} = 0,658$

Required area:

$$A_{s1} = \frac{\eta \cdot f_{cd} \cdot b_{eff} \cdot \lambda \cdot d \cdot \xi}{f_{yd}} = \frac{\eta \cdot f_{cd} \cdot b_{eff} \cdot d \cdot \xi \cdot \lambda}{f_{yd}} = \frac{1 \cdot 12 \cdot 10^3 \cdot 1 \cdot 0,08 \cdot 0,0056 \cdot 0,8}{336,6 \cdot 10^3}$$

$= 1,27 \cdot 10^{-5} \text{ m}^2 = 0,127 \text{ cm}^2$

Maximum reinforced points:

$A_{smin} = 0,26 \cdot (f_{ctm} / f_{yd}) \cdot b_t \cdot d = 0,26 \cdot (1,5 / 400) \cdot 1 \cdot 0,08 = 7,8 \cdot 10^{-5} \text{ m} = 0,78 \text{ cm}^2$

$A_{s1} = 0,127 < A_{smin} = 0,78 \text{ cm}^2$ • We choose the biggest.

• GRID OF $\varnothing 10 \text{ C}/200 \text{ m}$

• Frontal edge calculation:

1) CALCULATION OF LOADS:

$Q = G + P1 + P2 = 1,47 + 0,19 + 10,40 = 12,06 \text{ KN/m}$

2) CALCULATION OF M_{ed} and V_{ed} :

$M_{ED} = (Q \cdot L^2) / 8 = (12,06 \cdot 1,2^2) / 8 = 2,17 \text{ KN/m}$

$V_{ED} = (Q \cdot L) / 2 = (12,06 \cdot 1,2) / 2 = 7,236 \text{ kN}$

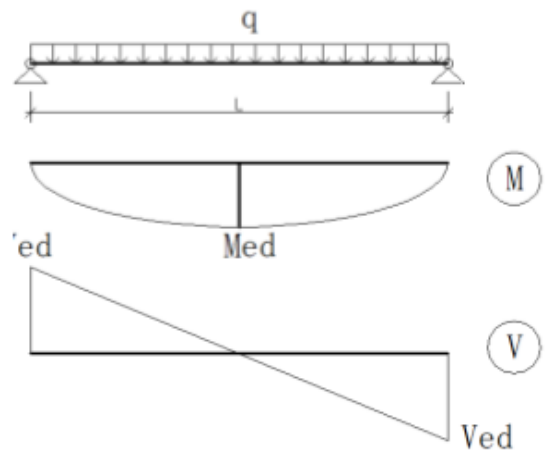

Become wide to theoretical section:

$$- b_{\text{eff}} = 2 (L/6) + b = 2 \cdot (120 / 6) + 10 = 50 \text{ cm}$$

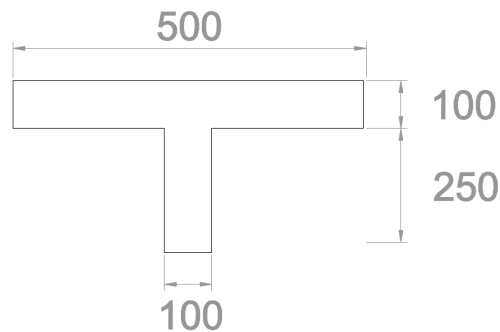

$$M_f = \eta \cdot f_{cd} \cdot b_{\text{eff}} \cdot H_F \cdot \lambda \cdot (d - 0,5 \cdot H_F \cdot \lambda) = 1 \cdot 12 \cdot 10^3 \cdot 0,50 \cdot 0,10 \cdot 0,8 \cdot (0,31 - 0,5 \cdot 0,10 \cdot 0,8) = 129,6 \text{ kNm} \geq M_{ed} = 2,17 \text{ kNm}$$

$$(- \lambda = 0,8 \quad - \eta = 1 \quad - d = 0,31)$$

$M_f < M_{ed}$ The neutral line is on the shelf, shelf compressive zone. Reinforcing the area as the count rectangular element.

$$\mu_{ed} = M_{ed} / \eta \cdot f_{cd} \cdot b_{\text{eff}} \cdot d^2 = 2,17 / 1 \cdot 12 \cdot 10^3 \cdot 0,5 \cdot 0,31^2 = 0,00376$$

$$\xi = 1/\lambda (1 - \sqrt{1 - 2\mu_{ed}}) = 1/0,8 (1 - \sqrt{1 - 2 \cdot 0,00376}) = 0,0047 < \xi_{\text{lim}} = 0,658$$

Required area:

$$A_{s1} = \frac{\eta \cdot f_{cd} \cdot b_{\text{eff}} \cdot \lambda \cdot d \cdot \xi}{f_{yd}} = \frac{\eta \cdot f_{cd} \cdot b_{\text{eff}} \cdot d \cdot \xi \cdot \lambda}{f_{yd}} = \frac{1 \cdot 12 \cdot 10^3 \cdot 0,5 \cdot 0,31 \cdot 0,0047 \cdot 0,8}{336,6 \cdot 10^3}$$

$$= 2,07 \cdot 10^{-5} \text{ m}^2 = 0,207 \text{ cm}^2$$

Maximum reinforced points:

$$A_{s\text{min}} = 0,26 \cdot (f_{ctm} / f_{yd}) \cdot b_t \cdot d = 0,26 \cdot (1,5 / 400) \cdot 0,10 \cdot 0,31 = 3,02 \cdot 10^{-5} \text{ m} = 0,302 \text{ cm}^2$$

$A_{s1} < A_{s\text{min}}$ We choose the biggest.

$$\cdot A_{s1} = \emptyset 8$$

$$\cdot A_{s2} = \emptyset 8$$

TRANSVERSAL REINFORCEMENT CALCULATIONS:

· Transversal force: $V_{ED} = Q_{ed} \cdot L / 2 = 12,06 \cdot 1,5 / 2 = 9,6 \text{ KN}$.

$$V_{rdc} = (C_{rcd} \cdot k \cdot (100 \cdot \rho_1 \cdot f_{ck})^{1/3}) \cdot B_w \cdot d =$$

$$= (0,12 \cdot 1,80 \cdot (100 \cdot 0,0017 \cdot 25)^{1/3}) \cdot 0,1 \cdot 0,31 = 0,0094 \text{ Mn} \approx 9,4 \text{ kN}$$

$$\cdot C_{rcd} = 0,18 / \gamma_c = 0,12 \quad \cdot k = 1 + \sqrt{200/d} = 1 + \sqrt{200/310} = 1,80 < 2 ; K = 1,80$$

$$\cdot \rho_1 = A_1 / (B_w \cdot d) = 0,55 \cdot 10^{-4} / (0,1 \cdot 0,31) = 0,0017 < 0,02$$

$$V_{rdc} = V_{min} \cdot B_w \cdot d = 0,42 \cdot 0,1 \cdot 0,31 = 0,013 \text{ Mn} \approx 13 \text{ kN}$$

$$V_{min} = 0,035 K^{3/2} \cdot f_{ck}^{1/2} = 0,42$$

$$V_{ED} = 9,6 \text{ KN} > V_{rdc} = 9,4 \text{ kN}$$

The condition is satisfied, and therefore does not calculate the transverse reinforcement.

$$A_{s3} = \varnothing 10 \text{ C}/150 \text{ mm}$$

STAIRS REINFORCEMENT

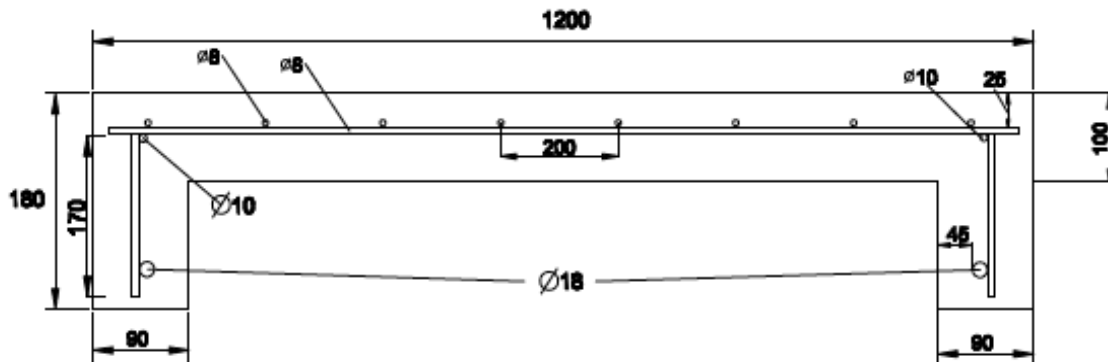

LANDING REINFORCEMENT

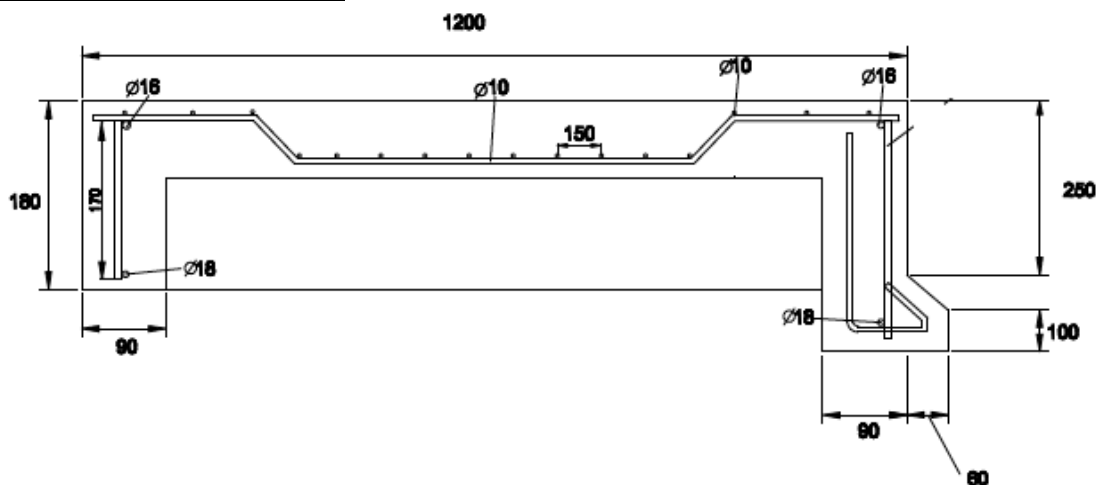

3. TECHNOLOGICAL CARD

3.1 TECHNOLOGICAL CARD OF SLAB STRUCTURE INSTALLATION-SECOND FLOOR.

3.1.1 GENERAL DESCRIPCION:

The technological card consist in the slab structure installation in the second floor of the building.

The horizontal structural part are solved with the same constructive system. Reinforced concrete slabs is the solution for the 7 floors in the ground and the 2 undergrounds. The thickness of the slabs is 220mm except in first floor slab is 250mm of thick. In areas where floors cantilever is longer than 2.0 m. It will be fitted capitals on the columns with dimensions 2000x2000 mm . The steel consists of a network overlays (upper and lower) of $\varnothing 12S500/220/\varnothing 12S500/220$ bars arranged in two orthogonal directions.(IMAGE 1,IMAGE2).

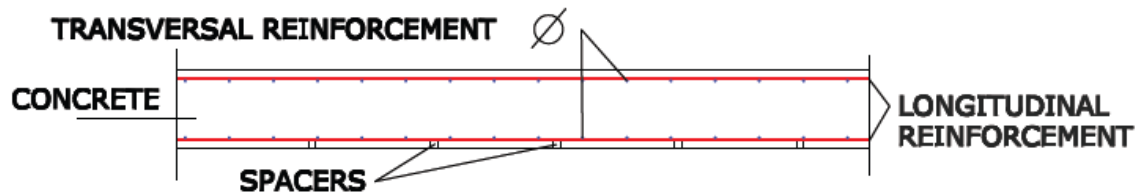

IMAGE 1. Slab section.

The total surface of concrete (2 grounds + 7 floors +1 roof) is 4118.25m². The duration of the work depends of the formwork placement. The process installation times are reduced as we move in height due to the repetition of the processes and the decrease of the surfaces. This kind of structural system has the advantage simplicity of execution, but presents the problem of big own weight. There are alternatives to solve this problem by introducing thinners elements.

3.1.2 DESCRIPTION OF TECHNOLOGY AND SEQUENCE OF WORKS:

The reinforced concrete building technique is the use of concrete reinforced with steel bars or meshes, called frames. it is also possible to assemble it with fibers, such as plastic fibers, glass fibers, steel fibers or combinations of steel bars with fibers depending on the requirements to which it is subjected.

WORKS ORDER:

- 1) WOOD FORMWORK PLACEMENT
- 2) REINFORCED PLACEMENT
- 3) CONCRETE PLACEMENT AND COMPACTION
- 4) CONCRETE CURING
- 5) REMOVING OF THE FORMWORK AND FINISHES

1) WOOD FORMWORK PLACEMENT:

The formwork must contain and support the fresh concrete during curing while maintaining the desired shape without deforming. They are usually of wood or metal and are required to be rigid, durable, watertight and clean. In assembly should be secured so that during the subsequent consolidation of the concrete there is no movement.

2) REINFORCEMENT PLACEMENT :

The armor must be clean and secured to the formwork and each other so that the intended position remain motionless on the concrete pouring and compaction. The distances between the various reinforcement bars must maintain a minimum spacing is normalized to enable correct placement of the concrete between the bars so that there are no gaps during compaction of the concrete. Similarly, the clearance between the steel bars and the formwork, called coating must maintain a minimum separation, also standardized, which allows the filling of this space by the concrete.

3) CONCRETE PLACEMENT AND COMPACTION:

The fresh concrete poured inside the formwork must be made to occur by preventing segregation of the mixture. This should avoid pouring from a great height, up to two meters.

It is placed in layers or tiers of thin horizontal to allow good compaction.

To achieve a compact concrete, eliminating the voids and to obtain a complete closing of the mass, there are several systems consolidation. Compaction by vibration is usual concretes resistant and is suitable in dry consistencies. The needle remains vertical in the mass of fresh concrete, introduced in each tier until the tip to penetrate the previous layer, taking care not to touch the armor.

3.1 RECOMMENDATIONS:

- The discharge must not be from a great height (one to two meters or less in freefall), ensuring that its direction is vertical and horizontal displacements of avoiding mass. The concrete should be targeted during pouring through chutes or other devices to prevent their clash against the form free or armor.
- The placing was effected by layers or tiers of horizontal thickness which allows a



good compaction of the mass (generally 20 to 30 cm, without exceeding 40 cm in the case of plain concrete or 60 cm reinforced concrete .

- Do not throw the concrete with shovel at a great distance, or distributed with rakes to not break it, or you will advance more than one meter within the forms.

- In parts heavily armed and, in general, when conditions are difficult placement, you may want to avoid voids and lack of adherence to the reinforcement, place a layer of 2-3 cm of the same aggregate concrete but free thick, immediately after pouring ordinary concrete.

- In the concreting of sloping surfaces, the fresh concrete has a tendency to run or slide down, especially under the effect of vibration. If the layer thickness and slope are large, it is necessary to use a higher formwork. Otherwise, this can be concreted without placing the concrete contraencofrado bottom up, by threads, the volume and distance to the compacted and should be calculated so that the concrete takes its final position after a short action of the vibrator.

4) CONCRETE CURING:

Curing is one of the most important operations in the process of putting in work for the decisive influence it has on the strength of the final element. During setting and hardening occur first evaporative water loss. We must compensate for these losses by adding curing the concrete to allow large amounts of water to develop new processes for hydrating with increased resistance.

5) REMOVING OF THE FORMWORK AND FINISHES

Removal of the formwork is performed when the concrete has reached a sufficient hardness. In the normal portland usually a period ranging between 3 and 7 días.³⁴ After stripping needs repair small holes or surface defects usually surface voids. If these defects are large or are in critical areas resistant may need partial or full demolition of the constructed element.

IMAGE 2. Order of works.

- ① STRUCTURAL SUPPORT FOR THE FORMWORK
- ② WOOD FORMWORK
- ③ SEPARATION ELEMENT FOR THE ARMOUR
- ④ ARMOUR PLACEMENT ACCORDING TO LAYOUT
- ⑤ CONCRETE PLACEMENT AND COMPACTION

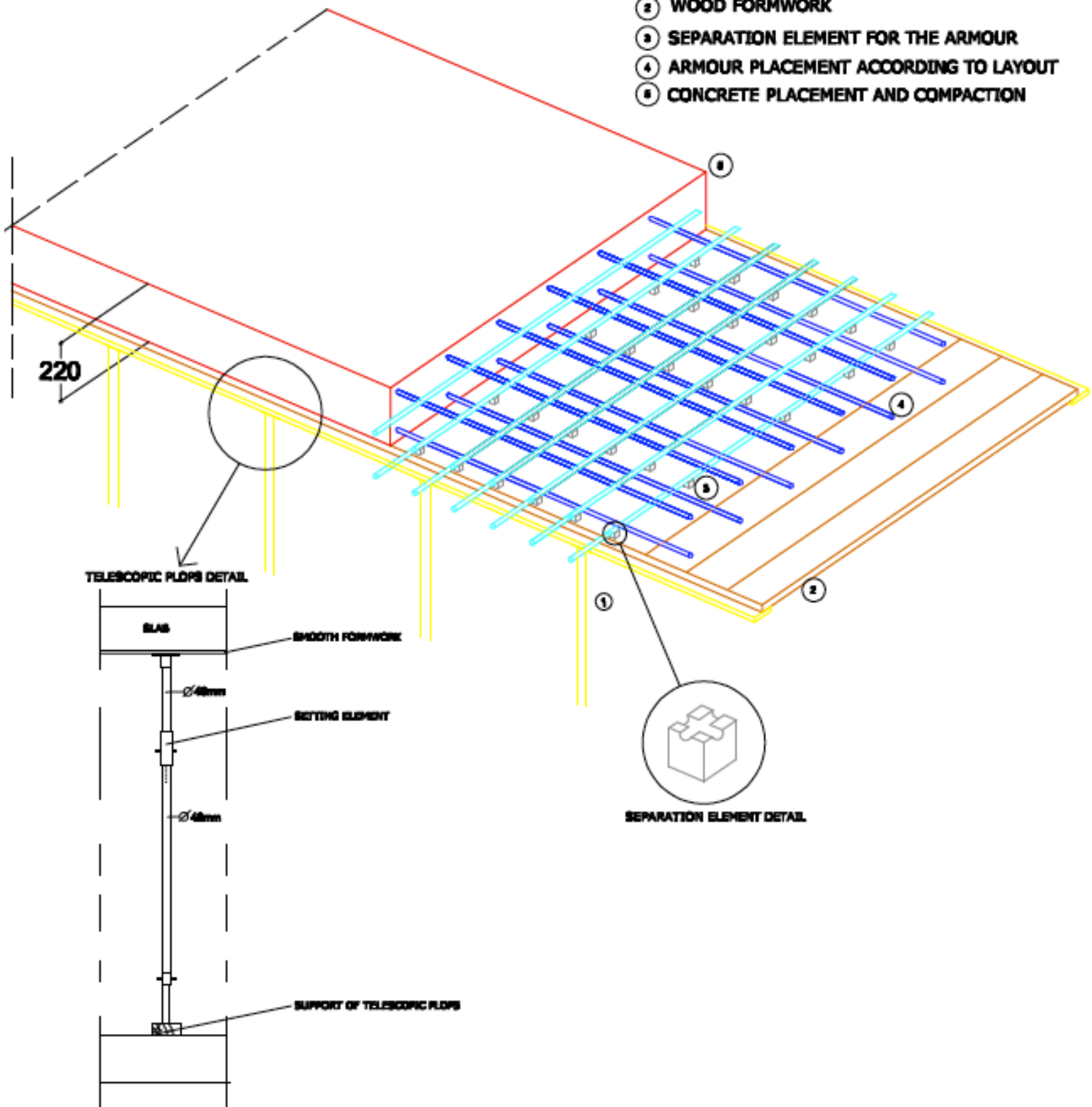

3.1.3 INSTALLATION SEQUENCE. FROM DAY ONE TO DAY THREE:

The sequence of works will be according to the arrows picture (IMAGE 3). Starting in day one to day three.

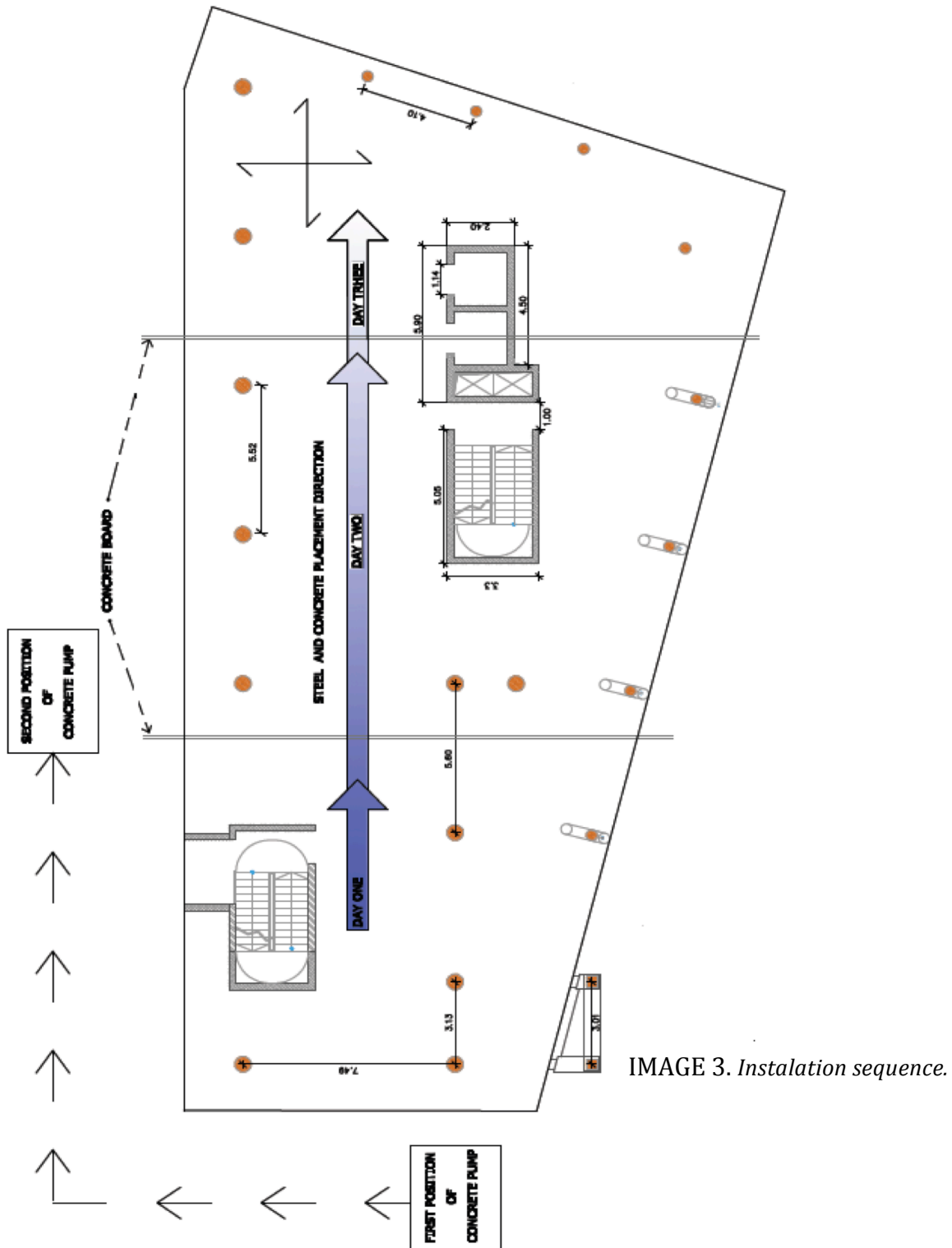
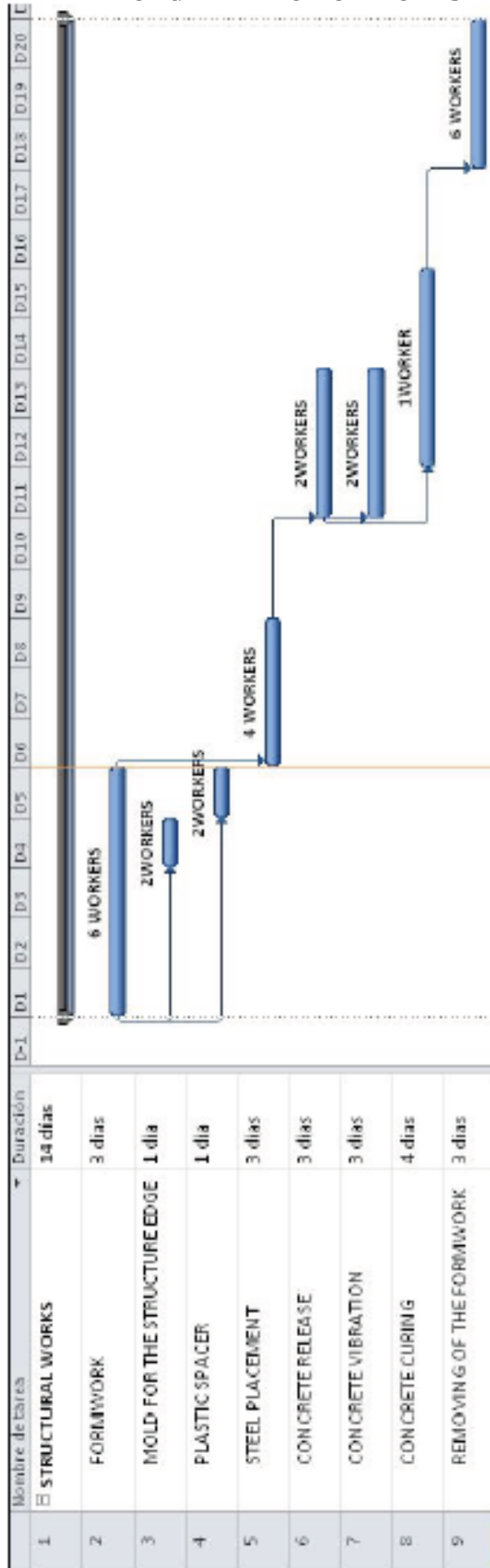

IMAGE 3. Instalation sequence.

ORGANIZATION OF WORKS



3.1.4 HUMAN SAFETY

THE WORKS MUST BE CARRIED OUT IN ACCORDING HEALTH AND SAFETY RULES IN CONSTRUCTION REQUEST:

A) INDIVIDUAL PROTECTION EQUIPMENT :

1. the operators handling the concrete hose by rope (not directly take the hose), provided with gloves, boots, helmet and goggles concrete projections.
2. protective gloves.
3. security boots.
4. water shoes.
5. protection glasses.

B) COLLECTIVE PROTECTION EQUIPMENT:

1. safety net in the first structural floor.
2. safety harness for all the workers.
3. perimeter railings on each floor of the work.
4. holes in the floor must be covered with net.
5. walkways and ramps at the same or different level.
6. working platform: for working at height.

3.1.5 MATERIAL - TECHNICAL RESOURCES

NUM	NAME	UNITS	QUANTITY
1	MACHINES		
1.1	CHAINSAW WOOD	UNITS	ONE
	CONCRETING PUMP	UNITS	ONE
	VIBRATOR	UNITS	ONE
2	MATERIALS		
2.1	NAILS	UNITS	500
2.2	COLOR SPRAY FOR LAYOUT	UNITS	2
2.3	METAL WIRE	METERS	MANUFACTURER
	SPACERS	UNITS	2112
	WOODEN BOARD	m ²	580,8
3	TOOLS		
3.1	LEVEL	UNITS	4
3.2	HAMMER	UNITS	8
3.3	PLIERS	UNITS	4
3.4	TELESCOPIC PLOPS	UNITS	1214,4

3.1.5.1 PLACEMENT EQUIPMENT

The transport of the concrete will be with truck and it will be placed with concrete pump. (IMAGE 4).

Transport conditions:

- During transport, should be segregated coarse aggregate, resulting in the loss of homogeneity and concrete strength. Avoid vibrations and shocks as well as an excess of water, which promote segregation. Aggregates boulders are more likely to segregate the crushing, given the greater internal friction of the latter.
- The concrete must be prevented from drying during transportation.
- If upon arrival at the pit concrete placement initially accused of setting, the dough should be discarded and not placing.
- When using concretes of different types of cement, carefully cleaned of vehicles before making the change.

Pump conditions:

Pumped concrete requires a cement content not less than 300 kg/m³ and use sand and coarse aggregate other than crushed. The dosage of the concrete must be done by weight. You should use a plasticizer or free flowing and use soft-plastic consistencies. Appropriate to the use of pozzolanic cement, the plasticity conferred by the concrete. The maximum aggregate size should not exceed 1/4 the diameter of the pipe if it is metallic, or 1/3 if plastic. Not be used aluminum pipe, a material that reacts with alkali from the cement. The placement should be avoided direct projection of the jet of concrete against armor, you have to monitor that the concrete does not appear segregated because of compressed air, and precautions should be taken with regard to operator safety.

IMAGE 4. Placement – Equipment.

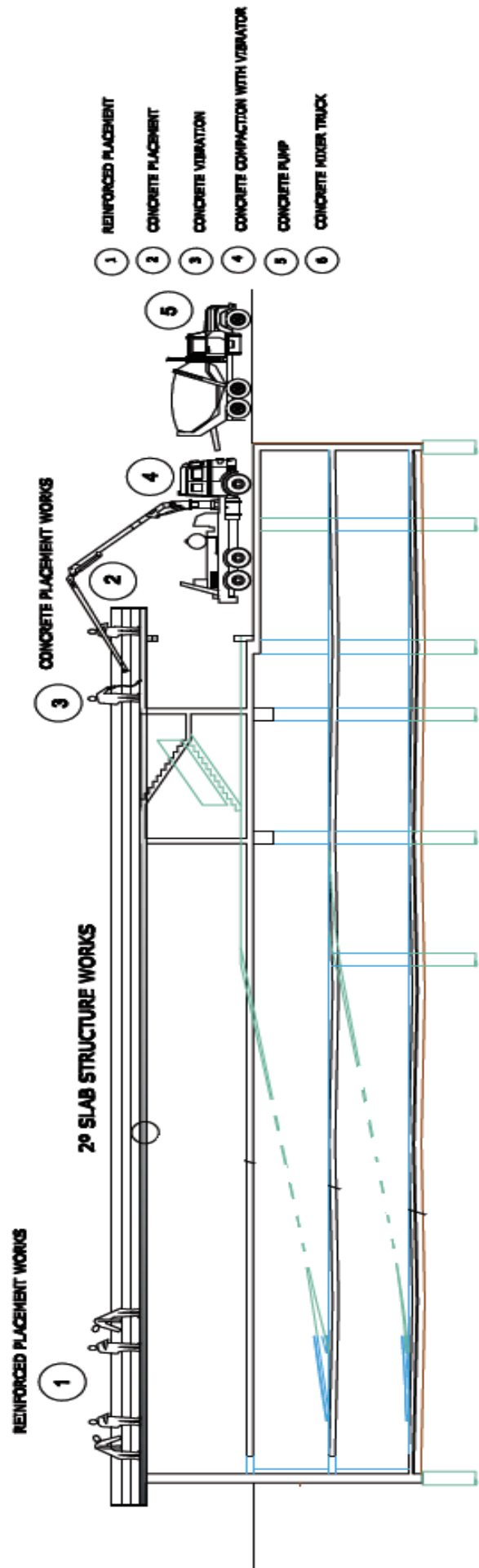

3.1.6 QUALITY CONTROL

The testing of concrete is done in their two states to meet their fresh and hardened properties to determine their qualities and strength. The behavior of concrete against the various efforts is variable and complex.

CONTROL TEST:

1) Depending on their nature:

- Destructive: determine the strength by breaking concrete test pieces or parts.
- Nondestructive: determine the quality without destroying the structure.

2) According to its purpose:

- Previous tests: determine the dosage of the material a agree with the conditions of implementation. Are performed before starting the work.
- Characteristic tests: check that the strength and dispersion of in situ concrete is located within the project.
- Control tests: test pieces molded in situ to verify the strength of the concrete is maintained equal to or greater than required.
- Testing information: claim to know the strength of concrete for a portion of the work and a certain age.

TOLERANCES:

Deviations are permitted in concrete in accordance with the picture. (IMAGE 5).

TOLERANCES

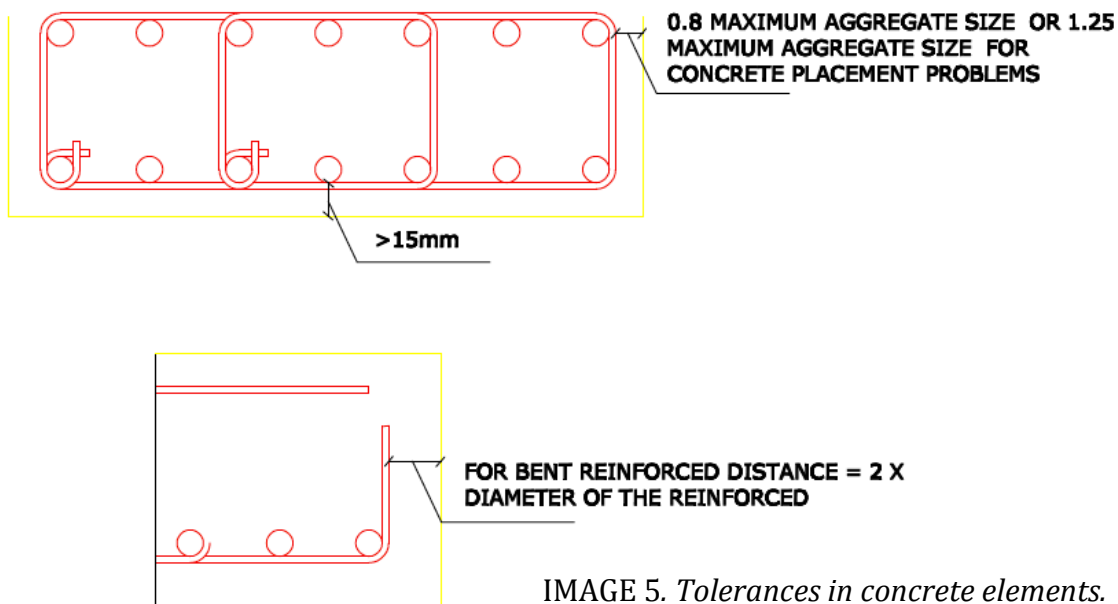

IMAGE 5. Tolerances in concrete elements.

3.1.7 DETAILS

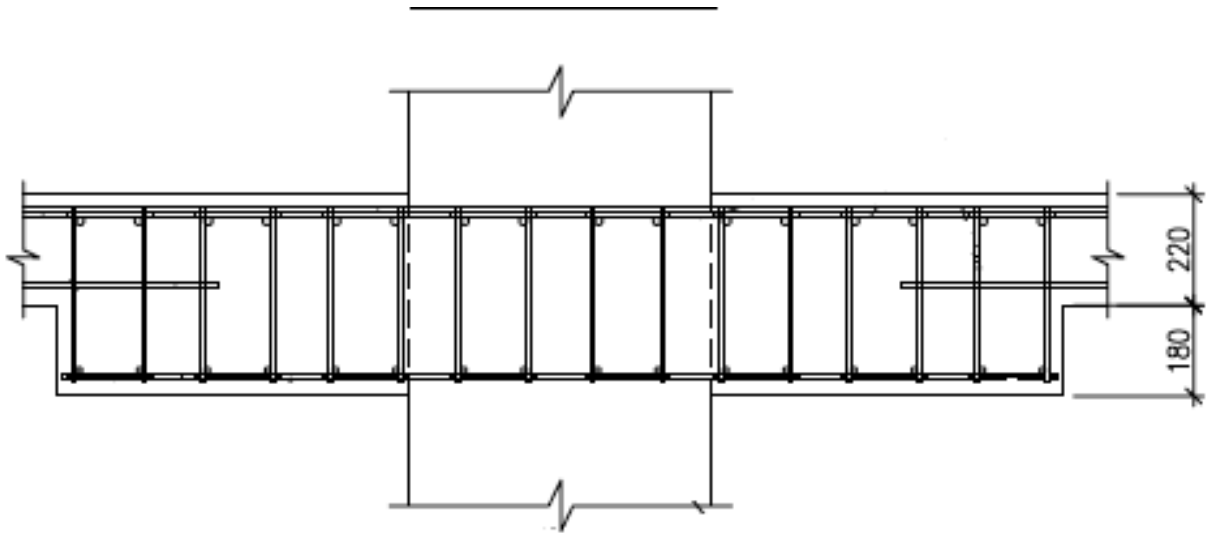

IMAGE 6. Detail of capitals on the columns with dimensions 2000x2000 mm.

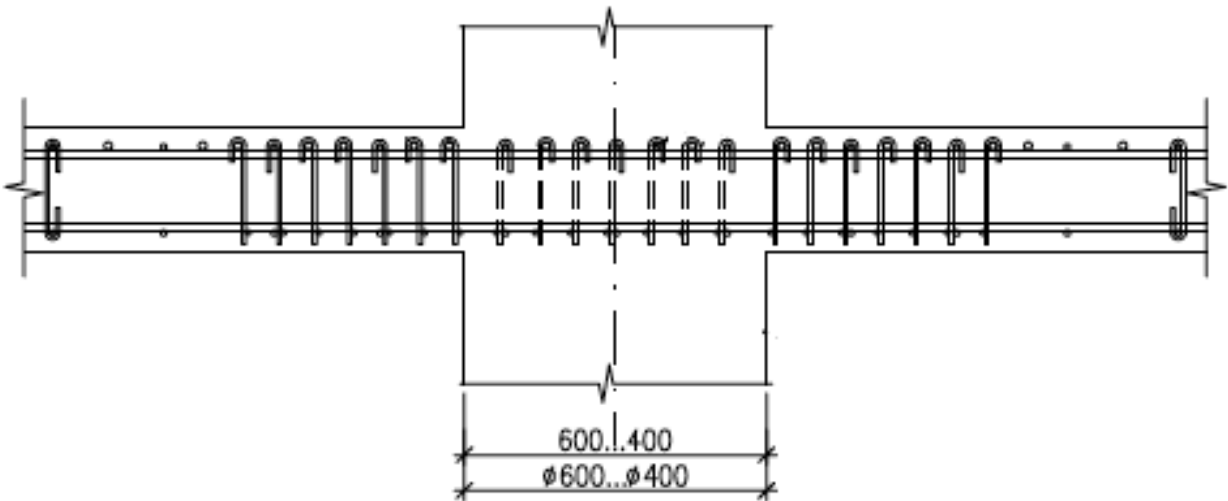

IMAGE 7. Detail of the Slab reinforced in columns zone.

3.1.8 CALCULATION OF QUANTITY OF WORKS AND PRICE

Reinforced concrete Floor structure, height 220 mm; HA-30/B/20/IIa+H steel B 400 SD.

Ud	Description	Rend.	p.s.	cost
m ²	Wood casing	1,050	14,32	15,04
h	Concrete vibrator	0,160	1,42	0,23
m ³	Water	0,100	1,89	0,19
kg	Steel UNE-EN 10080 B 400 SD	22,000	0,90	19,80
m ³	HA-30/B/20/IIa+H	0,200	70,73	14,15
h	Building official	0,090	22,91	2,06
h	Regular worker of construction	0,045	21,90	0,99
h	Regular assitant of contruction	0,090	22,53	2,03
h	Regular steel worker	0,184	21,31	3,92
h	Steel official	0,184	23,91	4,40
%	Direct cost	0,035	47,77	1,67
			Total x meter	64,47
			Total meters	528,12
			Total price	34045,641 € / 117287,22 litas

· Total cost for one floor: 34.045,641€ or 117.287,22 Litas.

SURFACES CHEKING:

1) $13.06+4.36+2.82=20.24 \text{ m}^2$

2) $84.8+3.75+3.75+19.87+5.36+8.9+14.62+10.85+10.85+10.85+22.09=195.63 \text{ m}^2$

3) $34.07+24.04+3.14+3.14+16.74+12.37+12.37+12.37+12.37+3.36+8.83+22.33=165.13 \text{ m}^2$

4) $34.62+14.06+2.93+2.93+26.68+11.62+11.62+23.38+7.3+11.98=147.12 \text{ m}^2$

TOTAL: $20.24+195.63+165.13+147.12 =528.12\text{m}^2$

3.1.9 TECHNICAL - ECONOMIC INDICATORS

1. Quantity of works: 528.12m²

2. Instalation cost : 34053 €/117313.22 LITAS

3. Duration of works : 15 DAYS

4. Wage:

- Building Official 47.32h X 22.91 = 1084.80€/ 3737.1 LITAS

- Regular Worker of construction 47.12 X 22.59 = 1064€ / 3666,8 LITAS

- Regular assistant of construction 23,76 X 21.9 = 520.35€ / 1789.9 LITAS

- Steel official 9 7,152 X 23.91= 2322,9€ / 8002.4 LITAS

- Regular steel worker 97.15 X 21.31 = 2070.30€ / 7132.2 LITAS

3.2 TECHNOLOGICAL CARD OF CURTAIN WALL FACADE.

3.2.1 GENERAL DESCRIPCION:

The exterior walls of the building are determined by two types of Systems. These system are ventilated façade with ceramic plates and curtain wall. In this technological card we will focus on analyzing installation of curtain wall. The surface of the facade corresponding to the curtain wall is 1360m². This is the north facade and south facade. We can find tinted glazed and transparent glazed among which are the windows. This system is according all requirements of safety noise and thermal. In addition we have a modern solutions that exist. The curtain wall make the building sophisticated and modern. And it is a perfect combination with the other enclosure. With the particularity that the facade has an inclination that makes it even more interesting. (IMAGE 8).

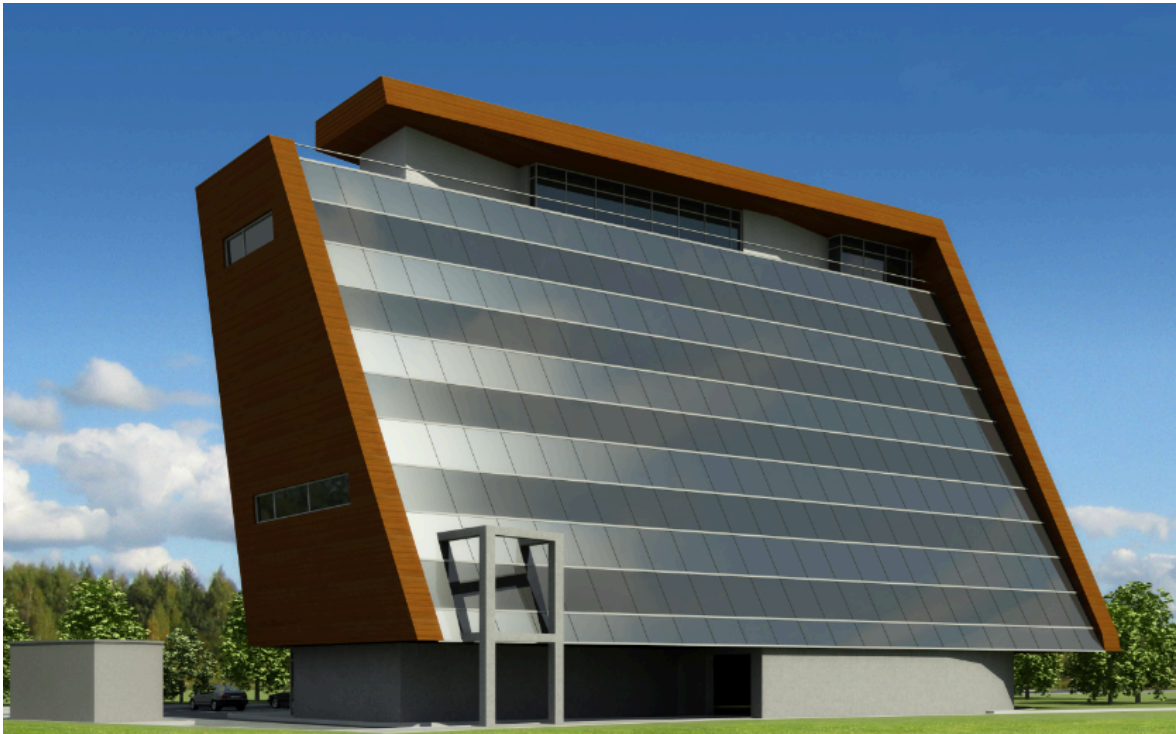

IMAGE 8. *Vision effect of curtain wall.*

3.2.1.1 LOCATION OF WORKS:

We can find this system in north and south facade. The grey zone in the (IMAGE 9) and (IMAGE 10).



IMAGE 9. South facade. The main facade.

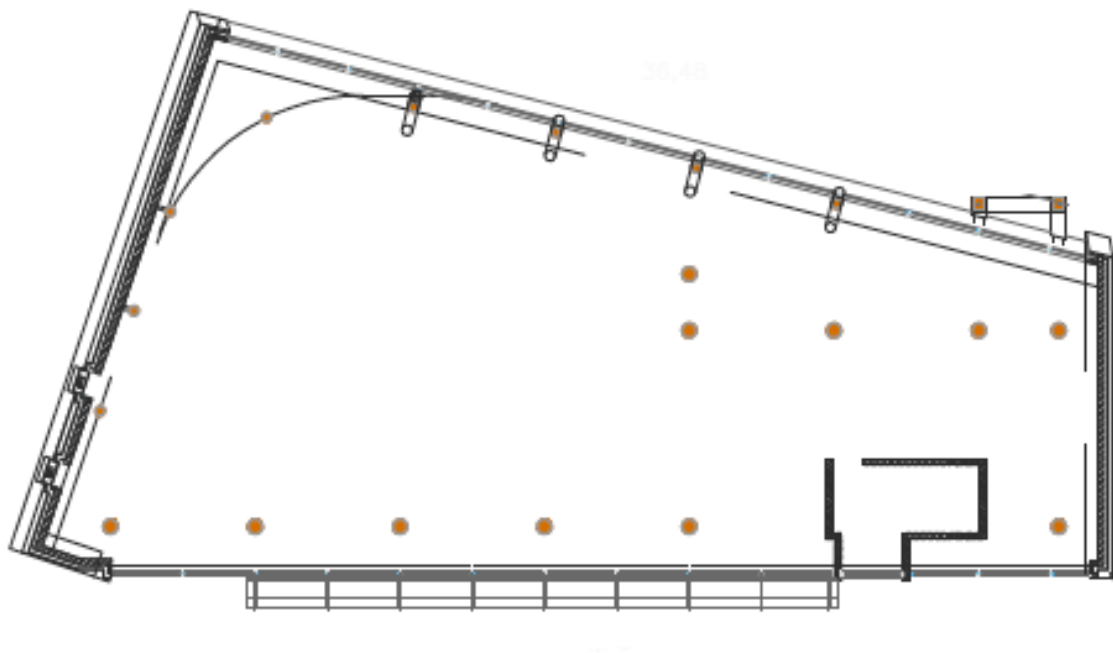

IMAGE 10. Aerial vision of curtain wall section.

3.2.2 DESCRIPTION OF TECHNOLOGY AND SEQUENCE OF WORKS:

Curtain wall is a term used to describe the facade of a building that bears no burden in the building. These loads are transferred to the main building structure through connections on the ground or in the columns of the building. A curtain wall is designed to resist air and water infiltration, seismic forces and their own loading forces.

The curtain wall is a front light mullion and transom that looks incredibly light and thin. Either vertically or horizontally, only a few millimeters are visible both from within and from without.

The curtain wall is constituted by a combination of elements of aluminum, a wide variety of glazing generally transparent and opaque areas, made of filler members which may be of different materials such as wood, composite panel, glass, plastics, etc..

WORKS ORDER:

- 1) LAYOUT OF THE STRUCTURE.
- 2) PLACEMENT GRID SUPPORT: UPRIGHT AND CROSSBARS.
- 3) PLACEMENT OF THE BLIND AND TRANSPARENT CRYSTALS.
- 4) FINISHES AND INSULATION.

1)SELF-SUPPORTING GRID:

It begins with the status of self-supporting aluminum grid that will host the panels, windows, doors and workable elements. Fixing the Uprights. The uprights are attached to the primary structure of the play and dominate over the horizontal cross. Assemble horizontally considering a certain amount of uprights as appropriate. At the top of the uprights is three-dimensional anchoring which allows corrections + - 20 mm.

The anchors have an element of EPDM at 80 ° Shore as an element of thermal break with anti also housed in the upper guiding elements and assembly for mounting to the next higher, movements of different types. Are also cast aluminum brackets which are fixed to corresponding studs. These works are repeated floor by floor, making intermediate checks to ensure no diversión plumb within a tolerance of + - 2%.

2) GLAZING:

We distinguish two types of filling:

- Blind zones
- Visible Zone.

Blind Zones Formed by an insulating layer and a monolithic glass.

In this case the panels are placed centered from the outside of the building by means of a system of splines. Begin by placing the reeds inside, positioning the panel with EPDM shims and securing support through other external splines. Then apply perimeter sealing seams. The sealant is placed at a temperature above 0 ° C prior to placement checking for grease, rust, moisture or dust.

The entire panel is joined to the uprights by caps placed under pressure and angular matching screw union with the horizontal profiles of the panel.

The monolithic glass plate bearing the same outer face of the insulating glazing vision, so that before installing other reeds are placed provided with EPDM gaskets in the hollows of rebate (in uprights and crossbars).

Then place the glass in the hole making perfect contact against the weatherstripping under pressure, and secured with two wedges of EPDM or silicone cured at 65 ° or 70° Shore of width equal to the thickness of the glass, with length less than 50 mm L/10 and the ends of the bottom side (L: length thereof).

To start closing the gaps, fixed with temporary staples. The final subject is effected by placing staples and thermal threaded screw heads stiles and rails, clamps and bridges are machined to achieve the same pressure between the outside and rebate funds, thus avoiding the introduction of air or leaks (Venturi effect).

Then comes the seals to ensure sealing in the meetings between the staples, before putting the lids and remove the labels affixed to the outside plant.

Zones Formed by Double Glazing Vision (Insulation):

Place the insulating volume in the gap between the grid of mullions and transoms making contact around the perimeter, having previously placed joints in them. Then takes place by means of centering wedges in the same manner as with the monolithic glass. The placement process, fasteners with ties, weatherstripping and sealing is effected just as the monolithic glass.

3) ISOLATION AND PLANT AUCTION:

To effect the closing of the curtain wall with the slabs, the bottom is achieved by performing the clamping moldings rock wool filling the space between the front of the slab and the curtain wall.

This allows a good thermal insulation, acoustic and prevents drafts and in case of fire, the probable spread of the flames.

At the top, the top is made of sheet molded Sendzimir type, which not only cover the anchorage of the floor but also make the mass support leveling screeds constitute the soils and support the final finish .

DIFFERENT WORKS:

MARKING:

It should first check with tape measure and level the situation of the songs of the floor and the pillars on the basis of the axes of the work. He checked the alignments, levels and weights, leaving as witness a stakeout batten used to mark level, facing and boot shafts supporting aluminum grid. Is eliminated by fixing the first floor of the grid curtain walls. **PRELIMINARY TASKS:**

While running the floors primary structure are the basis for anchoring the structure of aluminum, fixing, ensuring that they are plumb and level. Before beginning work it is found that the plants are clean, removing waste materials or forms that would have been.

ANCHORS:

The main structure has fixing bases provided to effect the necessary anchoring of the auxiliary structure.

SEALING:

The curtain wall should consist of elements for ensuring its tightness (thermal, acoustic), although this function can also fulfill a cladding of traditional work.

CONDENSATION:

In the auxiliary structure and the closure elements should be provided a water disposal system in the possible case of condensation, hence, the amount of the auxiliary structure must have a system thermal break.

3.2.3 INSTALLATION SEQUENCE

The sequence of works will be according to the numbers picture (IMAGE 11).

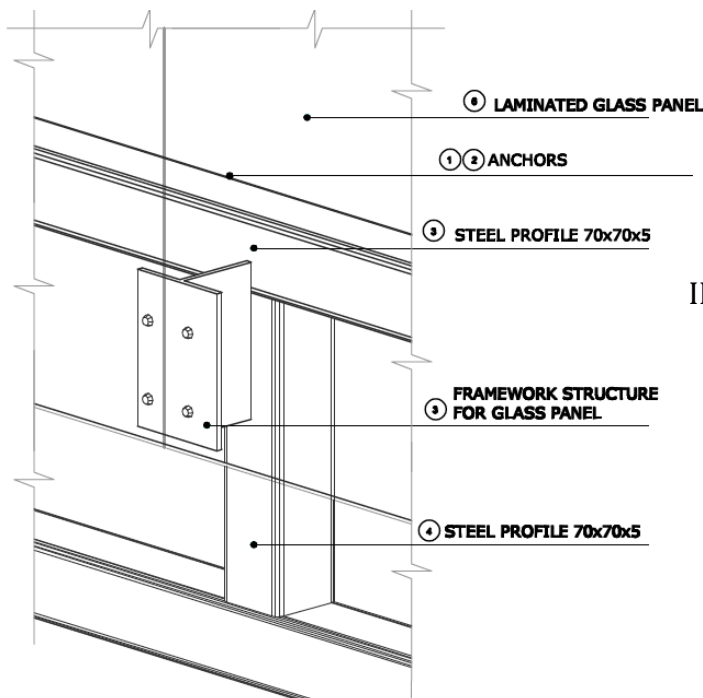

IMAGE 11. *Sequence of works scheme.*

DETAILS OF SEQUENCE

OF WORKS



1
STEEL PROFIL ANCHORS INSTALATION



2
STEEL PROFILE ANCHOR INSTALATION



3
VERTICAL STEEL PROFILE INSTALATION

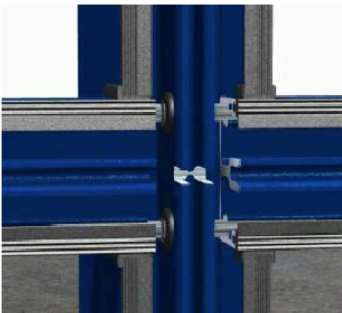

4
HORIZONTAL STEEL PROFILE INSTALATION

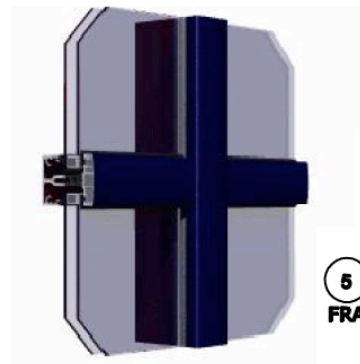

5
FRAMEWORK FOR THE GLASS PANEL



6
LAMINATED GLASS PANEL

IMAGE 12. Placement - Equipment

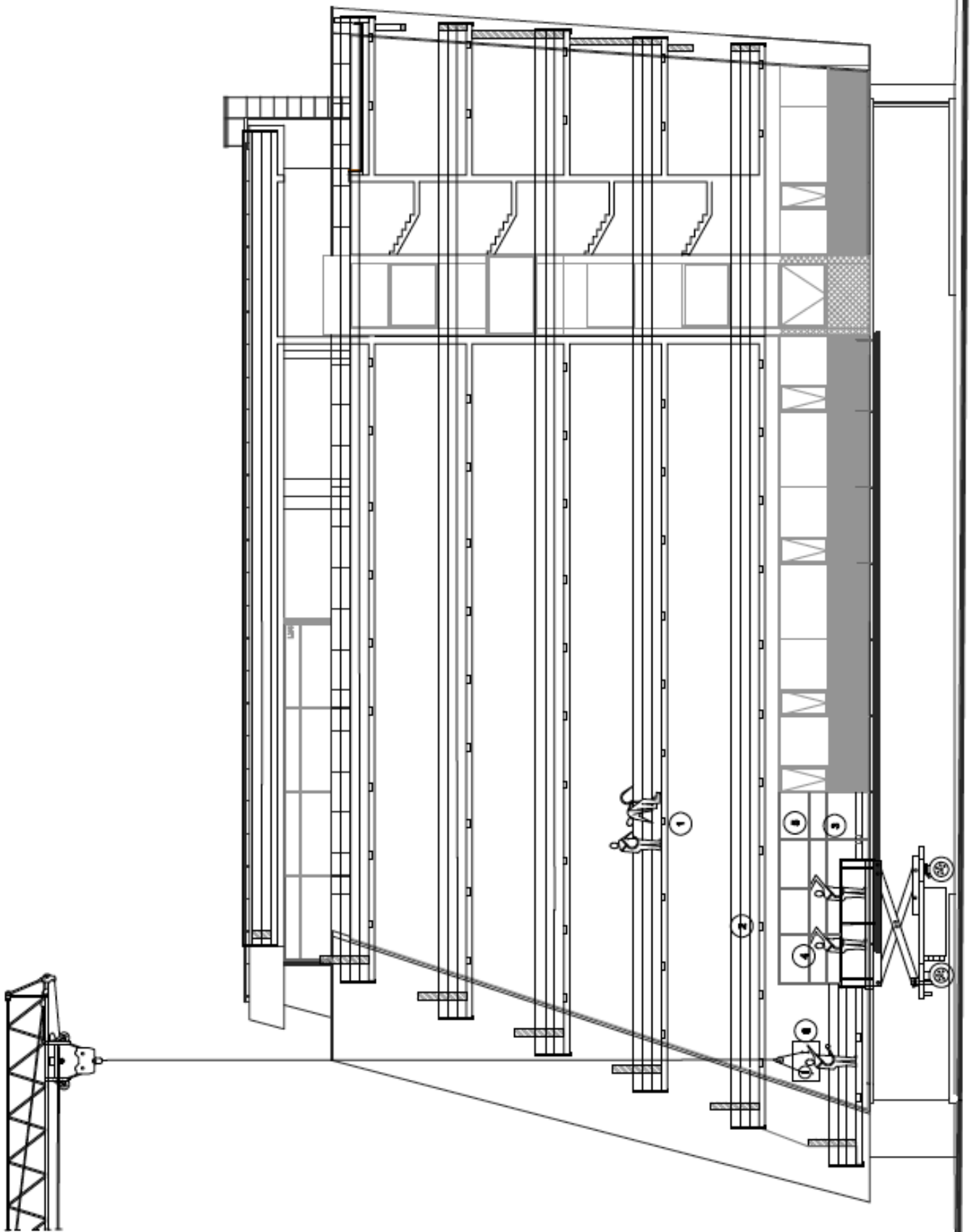

BORJA VICENTE ESTELLES CASADO

ORGANIZATION OF WORKS

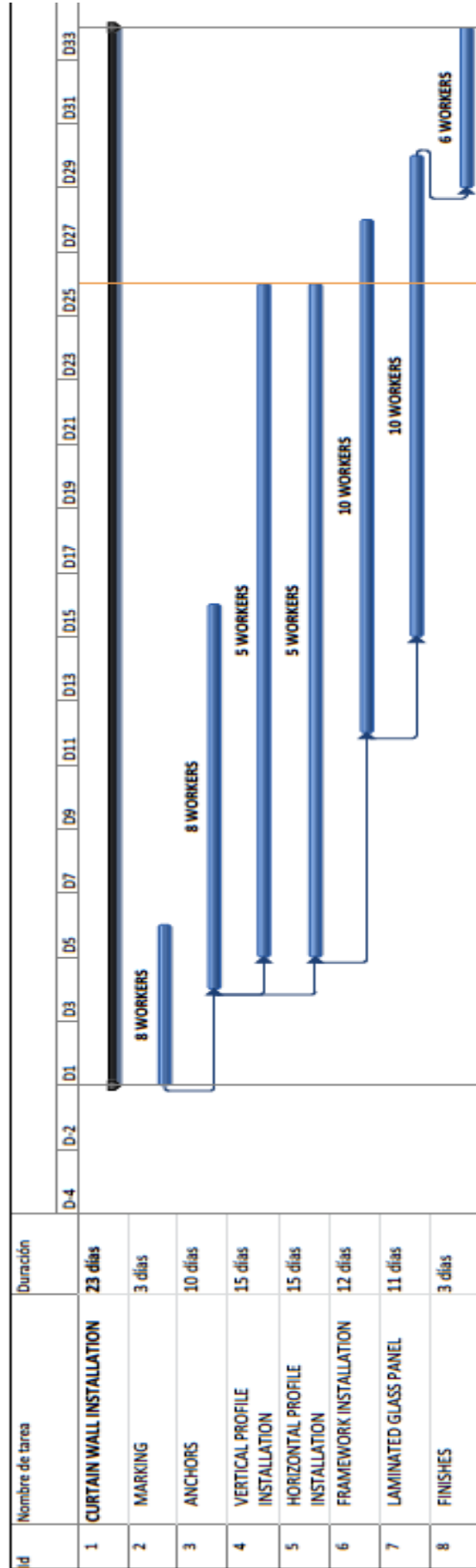

3.2.4 HUMAN SAFETY

THE WORKS MUST BE CARRIED OUT IN ACCORDING HEALT AND SAFETY RULES IN CONSTRUCTION REQUEST

INDIVIDUAL /COLECTIVES-PROTECTIONS FOR WORKERS:

- Guardrails
- Nets
- Lifelines
- Work area must be clean and tidy to prevent falls to workers at the same level
- Work clothes : full diver instead of two pieces of trousers and shirt
- Gloves
- Safety shoes and sock toe metal
- Welding shield (screen is better harness which holds the hand)
- Occasionally hearing protection
- Leather apron
- In tasks that require protection goggles
- If performing welding of lead will provide a suitable filter mas
- Helmet
- Safety harness anchored to the fixed part of the structure

3.2.5 MATERIAL - TECHNICAL RESOURCES

NAME	UNITS	QUANTITY
MACHINES		
ELEVATOR	UNITS	2
ELEVATION AND TRASPORTATION SYSTEM OF THE PANELS AND GLASS.	UNITS	ONE
DRILLS MACHINE	UNITS	4
SCREWDRIVERS MACHINE	UNITS	4
GRINDERS	UNITS	2
CIRCULAR SAW	UNITS	2
ELECTRIC WELDING EQUIPMENT OR RIVETER	UNITS	ONE
MATERIALS		
ESTRUCTURE COMPOSED OF ALUMINIUM STILES AND RAILS	METERS	857.52
TRIDIMENSIONAL ANCHOR SYSTEM	UNITS	218.006
ELEMENTS OF GUIDANCE AND ASSEMBLY	METERS	1648.8
STANDS FOR MOORING	UNITS	218.006
INSULATION PANELS	m ²	885.65
MONOLITHIC GLASS	m2	476.89
INSULATING GLASS	m2	885.65
BATTENS, FASTENERS AND GASKETS	m2	885.3
SILICONE	m2	681
TOOLS		
LEVEL	UNITS	8

3.2.6 QUALITY CONTROL

During the execution of the works will take place the following controls:

- Check the floors of the facade.
- Check dimensional anchors.
- Check stiles and rails.
- Check the welds on the anchors.
- Check sealed insulation.
- Glazing and / or glass.
- Check fasteners final.
- Auctions upper and lower floors.
- We must checks all materials used.

TOLERANCES FOR ALUMINUM PROFILES:

- Allowable tolerances on wall thickness of hollow profiles. d less than or equal to 250, $+ - + 2.3$ mm maximum - minimum 0.38 mm. d less than or equal to 600, $+ - + 2.3$ mm maximum - minimum 0.65 mm.
- Tolerances on fixed lengths. For $250 < \varnothing < 600$ mm (diameter circumscribed circle) nominal lengths $2000 < i < 25000$ mm. Tol: $+ 8/0$ mm to $+40 / 0$ mm.
- Flatness tolerances. For $50 < a < 600$ mm. In sections open, tolerance: 0.20 to 2.4 mm. In hollow sections, tolerance: 0.30 to 3.6 mm.
- Maximum torque tolerances. For $12.5 < \varnothing < 600$ mm. (circumscribed circle diameter) Tol: 0.010 to 0.140 mm / mm width.
- Tolerance of angles For $1.6 < h < 5$. Tol: 2° to 1° .

3.2.7 DETAILS

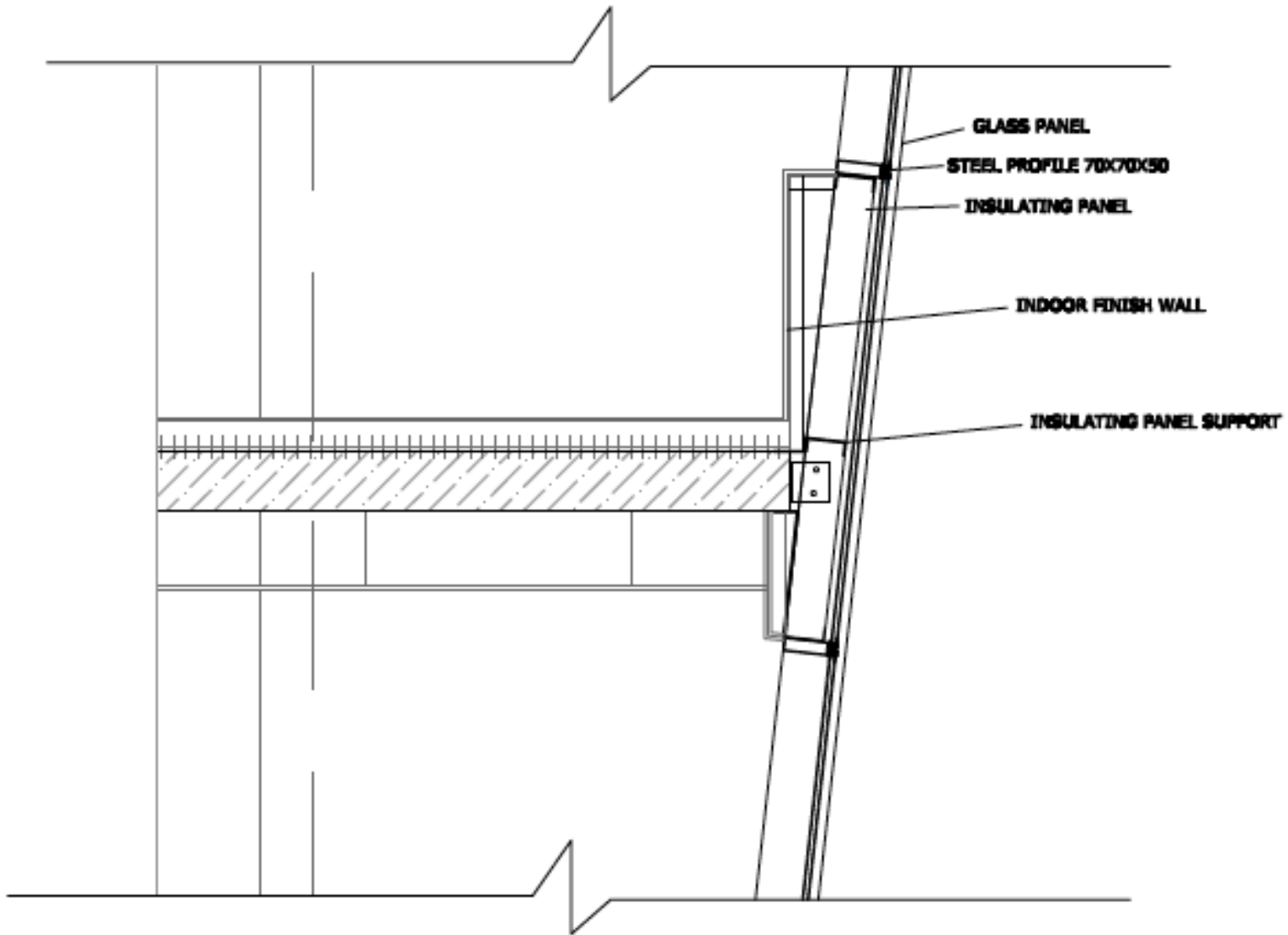

IMAGE 13. *Facade section. Curtain wall elements.*

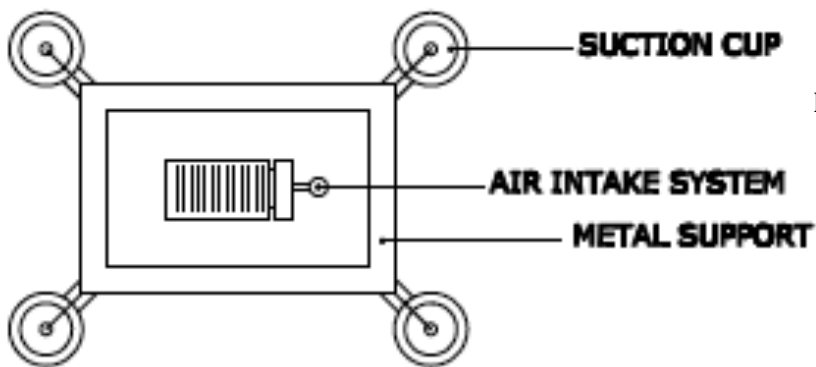

IMAGE 14. *Support system of glass panels.*

3.2.8 CALCULATION OF QUANTITY OF WORKS AND PRICE

Curtain wall facade doble glazed and insulated.

Ud	Description	Rend.	p.s.	cost
m	Aluminum profile tipe 1	0,600	10,64	6,38
m	Aluminum profile tipe 2	0,600	15,96	9,58
m	Aluminum sheet 20x52mm	0,600	3,50	2,10
u	Anchors	0,160	28,62	4,58
m ²	Silicon	1,000	4,00	4,00
m ²	Double glass	0,400	75,77	30,31
m ²	Tempered glass	0,600	48,22	28,93
m ²	Insulation	0,600	25,61	15,37
m ²	Sheet aluminium tipe 2	0,600	39,14	23,48
h	Carpentry assistant	2,200	18,41	40,50
h	Carpentry official	1,400	21,69	30,37
%	Direct cost	0,035	195,84	6,85
Total x meter				202,45
Total meters				1362
Total price				275739,08 € / 949.921,20 litas

· Total cost for the work 275.739,08 € or 949.921,20 Litas.

3.2.9 TECHNICAL - ECONOMIC INDICATORS

1) Quantity of works: $681.27\text{m}^2 \times 2 \text{ FACADES} = 1362\text{m}^2$

2) Instalation cost: 275.43798€ / 949.921,20 litas

3) Duration of works: 23 DAYS

4) Wage:

-Carpentry official 1907 x 21.69 = 41374.97€ / 142563.79 litas

- Regular assitant of capentry 2997 x 18.51 = 55485.35€ / 191147.04 litas

4. ORGANIZATION PART

4.1 DESCRIPTION OF TERRITORY

The function of our building will house the administration offices. It is located on the street narbuto N/ 35. The work plan includes the following works:

·Access and space for the working machines(trucks, concrete pump),fixed and mobile machines.

·Space for storage of building materials.

·Electricity supply, water supply, sewerage and fire hydrant.

·Perimeter areas of work:

-Danger areas in passing.

-Dangerous spaces for residence of workers.

-Access roads safe separation of workers and machinery access.

-Temporary buildings areas for workers and staff.

Before to start with the constructional works we must have prepare the construction master plan.

-The first job we have to plan is the removal of plants and trees that might disturb the execution of works.

-Must be removed 10 cm of soil and prepare the ground to begin the work of staking.

-This works will be done according to the organization project and we must we must meet the estimated execution times.

-We must put one fence in the perimeter of the contrucction work site with one signal panel of mandatory protective measures.

-We must pay attention to areas of crane installation and safety distances.

-Before to starting we mus prepare a big entrance for the supplied trucks and machinary.

-We must prepare the storage sites for the materials.

The storage zones are designed for this purpose. Have a previous study on the project. Be marked and identified. This zones will be near of the tower crane for easy acces and moving. It should have easy access to the material supply trucks.

The temporary buildings must be equipped with water and electricity. It must have electricity for electrical equipment and for the tower crane. There will be a transformer where we between the current from the general supply. This provision requires a specific license, which we must seek and obtain before starting work.

4.1.1 SELECTION OF TOWER CRANE

The selected tower crane is LIEBBHER 110 ECB6.

The reasons for we have chosen this crane are:

-The installation of the crane will be before commencing work excavation, so the crane may participate in this work.

-Technical parameters.

·CALCULATION OF TECHNOLOGICAL PARAMETERS OF TOWER CRANE:

For calculate the parameters we need to know:

A)The dimensions of building and location (underground and over-ground parts).

B)The weights, dimensions and location of installing constructions.

C)The work conditions (the peculiarities of building site, soil characteristics, the peculiarities of underground structures).

We must check the characteristics of the crane and check that they are compatible with our needs:

$$Q_k > Q_R.$$

$$H_k > H_R.$$

$$L_k > L_R.$$

Q_k – the ascension power of selected crane, t

Q_R – the required ascension power, t

L_k - the reach of selected crane boom, m

L_R - the required reach of crane boom, m

H_k - the lifting height of selected crane hook, m

H_R – the required lifting height of hook, m

The technological parameters of crane are calculating according to the building characteristics. The required crane is selecting according to the tables of technical characteristics of cranes.

First of all, using the next, formula the required height of hook lifting is determining:

$$H_R = h_1 + h_2 + h_3 + h_4 = 27.00 + 0.7 + 3.75 + 1.55 = 33.00\text{m}$$

h_1 – the height of abutment (support), on which the installing element is bracing, which is calculating from the under-crane track or the bottom of support, m

54

h_2 – the height of installing element, m

h_3 - free interval between abutment (support) and installing element.

h_4 – the height of hitching (trailing) equipment (strops) above the installing element, m.

Then the ascension power of crane is calculating using the next formula:

$$QR = P + Pstr = 2.2 + 0,104 = 2,304 \text{ t.}$$

P - the weight of heaviest lifting construction, T.

Pstr- the weight of hitching (trailing) equipment (strops), t.

For determining the reach of crane boom LR, These values are finding in crane diagrams.

$$LR = 1,25 + 1 + 1,5 + 3,8:2 + 20,95 = 26,6 \text{ m.}$$

After knows this parameters:

LR, HR, QR

The crane could be selected using the diagrams of the tower crane:

·The diagrams show, that the selected crane LIEBHERR TURMDREHKRAN 40 LC, match all requirements:

$$Q_k \text{ is } 2.6 > QR = 2,304 \text{ t}$$

$$H_k \text{ is } 42,1 > HR = 33 \text{ m}$$

$$L_k \text{ is } 39,6 > LR = 26,6 \text{ m}$$

·The tower crane selected (*IMAGE 1*) is capable of performing the required works.

LIEBBHER 110 ECB6.

·The tower crane supported basement (*IMAGE 2*).

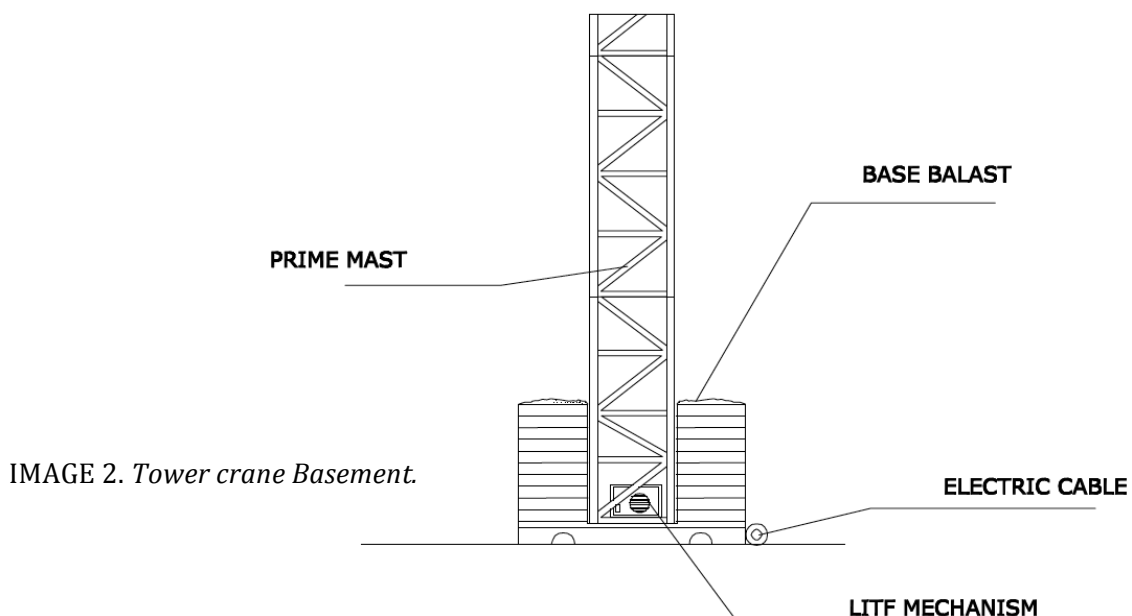

IMAGE 1. Selected Tower crane.

Turmdrehkran T10 EC-B 6

Tower Crane / Grue à tour / Gru a torre / Grúa torre
Guindaste de torre / Башенный поворотный кран

▶ T10 EC-B 6

T10 EC-B 6 FR.tronic[®]

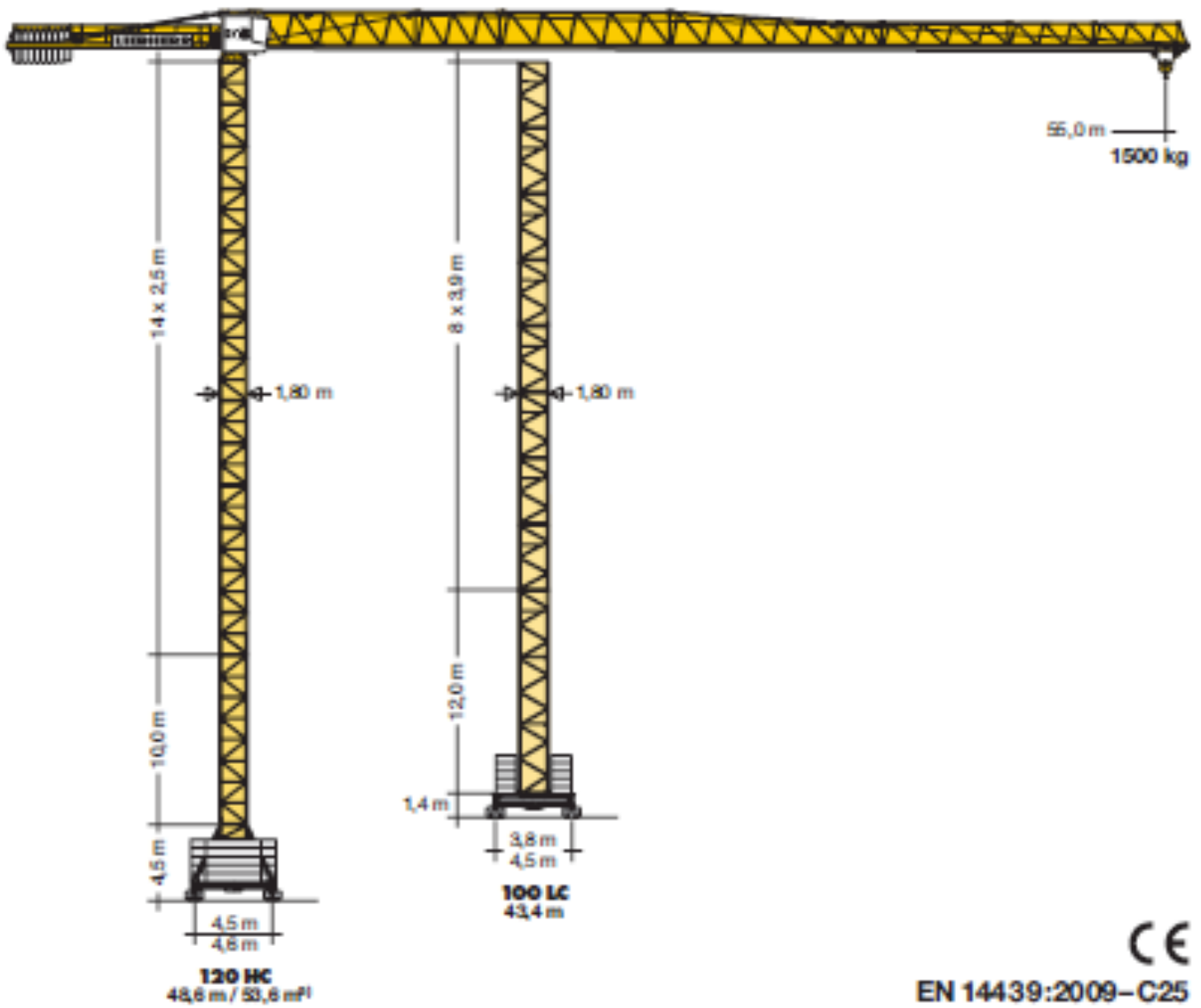

In the picture (IMAGE 3 AND IMAGE 4). We can see the main characteristics of the selected tower crane.

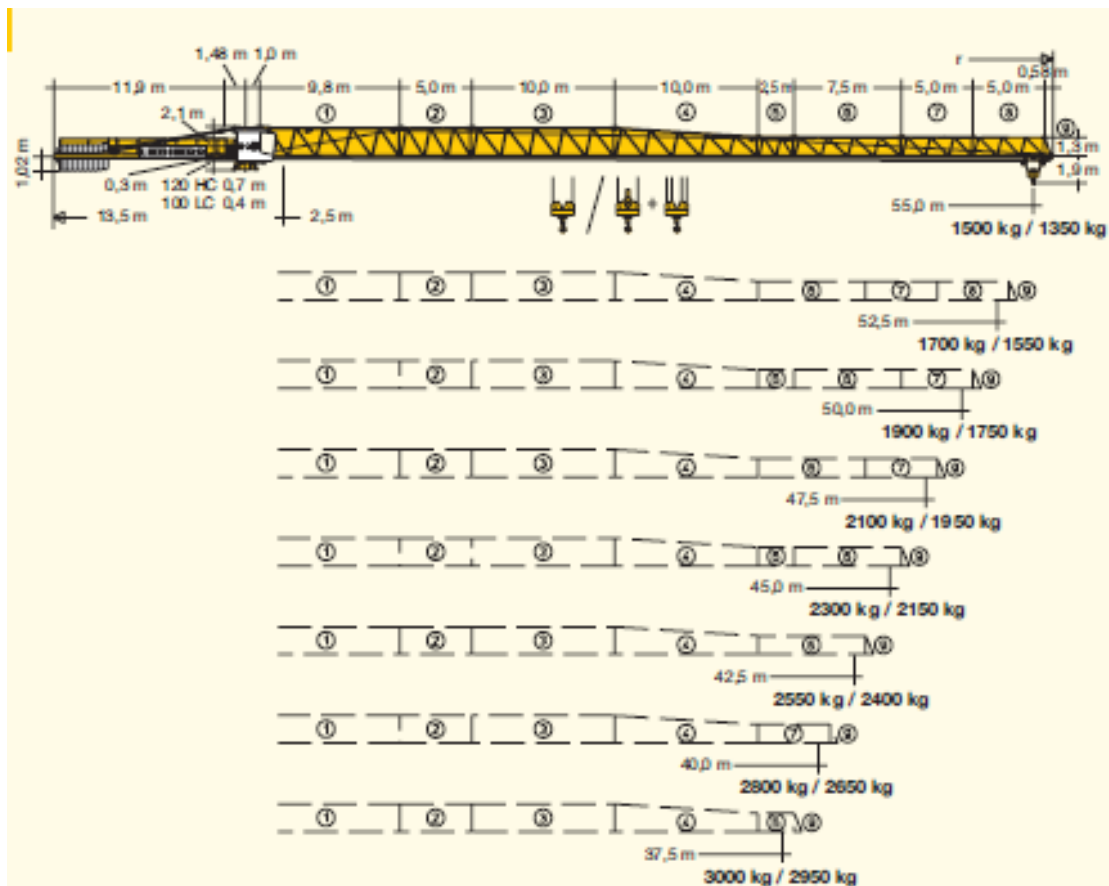

IMAGE 3. Tower crane reach.

m	r	m/kg	m/kg														
			20,0	22,5	25,0	27,5	30,0	32,5	35,0	37,5	40,0	42,5	45,0	47,5	50,0	52,5	55,0
55,0	(r = 56,5)	$\frac{2,5 - 31,3}{3000}$	3000	3000	3000	3000	3000	2850	2620	2410	2240	2080	1940	1810	1700	1590	1500
52,5	(r = 54,0)	$\frac{2,5 - 32,8}{3000}$	3000	3000	3000	3000	3000	3000	2780	2560	2380	2210	2060	1930	1810	1700	
50,0	(r = 51,5)	$\frac{2,5 - 34,3}{3000}$	3000	3000	3000	3000	3000	3000	2910	2690	2490	2320	2160	2020	1900		
47,5	(r = 49,0)	$\frac{2,5 - 35,8}{3000}$	3000	3000	3000	3000	3000	3000	3000	2780	2580	2400	2240	2100			
45,0	(r = 46,5)	$\frac{2,5 - 37,3}{3000}$	3000	3000	3000	3000	3000	3000	3000	2850	2650	2460	2300				
42,5	(r = 44,0)	$\frac{2,5 - 38,8}{3000}$	3000	3000	3000	3000	3000	3000	3000	2950	2740	2550					
40,0	(r = 41,5)	$\frac{2,5 - 40,3}{3000}$	3000	3000	3000	3000	3000	3000	3000	3000	2800						
37,5	(r = 39,0)	$\frac{2,5 - 41,8}{3000}$	3000	3000	3000	3000	3000	3000	3000	3000							
35,0	(r = 36,5)	$\frac{2,5 - 43,3}{3000}$	3000	3000	3000	3000	3000	3000	3000								
32,5	(r = 34,0)	$\frac{2,5 - 44,8}{3000}$	3000	3000	3000	3000	3000	3000									
30,0	(r = 31,5)	$\frac{2,5 - 46,3}{3000}$	3000	3000	3000	3000											
27,5	(r = 29,0)	$\frac{2,5 - 47,8}{3000}$	3000	3000	3000												
25,0	(r = 26,5)	$\frac{2,5 - 49,3}{3000}$	3000	3000													
22,5	(r = 24,0)	$\frac{2,5 - 50,8}{3000}$	3000														
20,0	(r = 21,5)	$\frac{2,5 - 52,3}{3000}$	3000														

IMAGE 4. Tower crane lifting.

·More information in the webpage of LIEBHERR :

<http://www.liebherr.com/es-ES/default.lh.wfw>

4.1.2 CONSIDERATIONS FOR THE CALCULATION OF THE DANGER ZONE:

During the installment works in some parts of the construction site, in bars, workplaces, and crossings the dangerous areas are appearing. In construction such areas are known as dangerous zones. In the beginning of construction works and during construction dangerous zones, in which constantly arise or may arise risk factors should be determined. The dangerous zones are dividing into two groups:

1. Dangerous zones, in which dangerous and (or) hazardous factors constantly affect the processes.
2. Dangerous zones, in which dangerous factors could appear.

1. DANGEROUS ZONES, IN WHICH DANGEROUS AND (OR) HAZARDOUS FACTORS CONSTANTLY AFFECT THE PROCESSES, ARE:

-Near the electrical equipment with non-insulated parts electric current (flow) (Table1).

- Fenceless zones at a height when height difference is 1.3 m and the higher;

- Places where hazardous wastes and (or) the concentration of harmful substances in workplace air may exceed the limit values.

TABLE 1: BOUNDARIES OF DANGEROUS ZONES WERE THE INFLUENCE OF ELECTRIC CURRENT (FLOW) COULD APPEAR:

Voltage, kW	Distances, limiting the dangerous zone from the fenceless uninsulated parts of the electrical equipment or from the vertical plane, which is the nearest power line wire, with a projection on the land, m
< 1	1,5
1 ÷ 20	2,0
35 ÷ 110	4,0
150 ÷ 220	5,0
330	6,0
500 ÷ 750	9,0
800 (current)	9,0

The boundaries (limits) of dangerous zones, were appear the risk factors of harmful substances exceeding should determined by measurements.

2. DANGEROUS ZONES, IN WHICH DANGEROUS FACTORS COULD APPEAR, ARE:

- Near buildings under construction and assembling (or dismantling) building structures or equipment;
- Places over which the structures or equipment installation (or dismantling) works are executing;
- Places over which loads are lifting and transporting by cranes;
- Places where the machinery, their parts or work equipment are moving.

THE DETERMINATION OF CRANE DANGEROUS ZONES:

The limits of dangerous zones areas, where there is transfer of elements is performing by cranes, are determining by calculation the sum (total distance) of horizontal projection if lifted element, the maximum dimension (length) of biggest element and it's possible fall distance.

The limits of dangerous zones near structures are determining by summarizing the maximum dimension (length) of biggest installed element and its possible fall distance.

$$R_{pav} = l + 1/2 l_1 + r \text{ (IMAGE 5).}$$

- R_{pav}: danger tower crane area
- L: boom length
- l₁: the biggest dimensional structure length
- r: distance of the danger zone Stocks

$$R_{pav} = 39.79 + 1/2 \times 5.5 + 8.7 = 51,24\text{m}$$

IMAGE5. Distances for dangerous zone calculations.

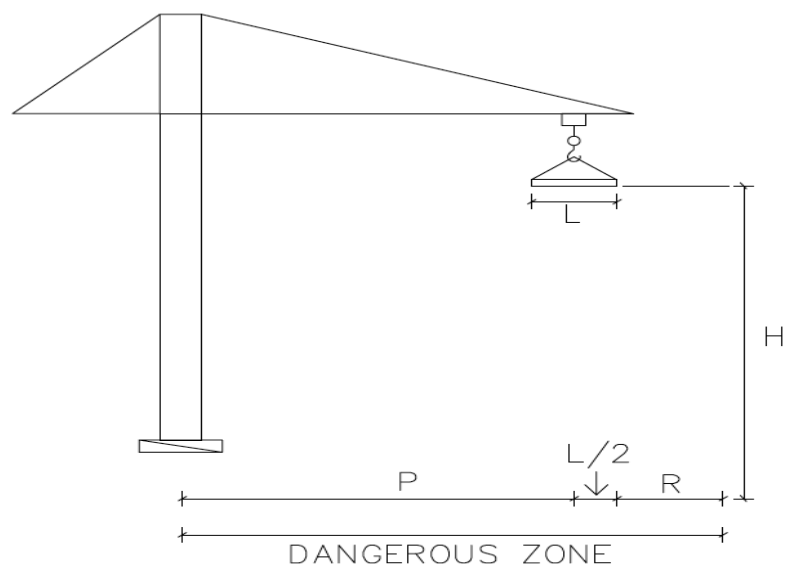

ANOTHER RISK:

Addition to the load of the danger zone, we must consider the presence of other elements / obstacles equally dangerous, this risk are analyzed and established security measures in the following standards:

-Royal Decree 836/2003 of 27 June, approving a new Technical Instruction "MIEAEM2" Regulations Lifting and handling equipment, referring to tower cranes for construction or other applications.

-Royal Decree 1215/1997 of 18 July laying down minimum safety and health for use by workers in teams. It should be borne in mind also that through Article 5 of the ITC-MIEAEM2, binding is established in the UNE 58-101 - 92, Part 2: Lifting heavy equipment. Terms of strength and safety removable crane works. Conditions of installation and use.

THESE ESTABLISHED RISK WILL BE:

- PRESENCE OF OBSTACLES.
- AREAS OF WAY.
- JOBS IN PROXIMITY TO HIGH VOLTAGE POWER LINES.

-PRESENCE OF OBSTACLES.

In paragraph 7.3 of the UNE 58-101-92, states: *The vertical clearance between the pen and the last area of movement of personnel shall be 3 m minimum. If the load or empty hook passes within 3 m of the area, will be necessarily placed on it enough to prevent the indicators of his approach. In the figures (IMAGE 6) we can observe the measures wich are referenced in the normative. We have considered a minimum distance between the tip of the arrow and the nearest obstacle of 2m. (IMAGE 7).*

IMAGE 6 AND 7. Security distances

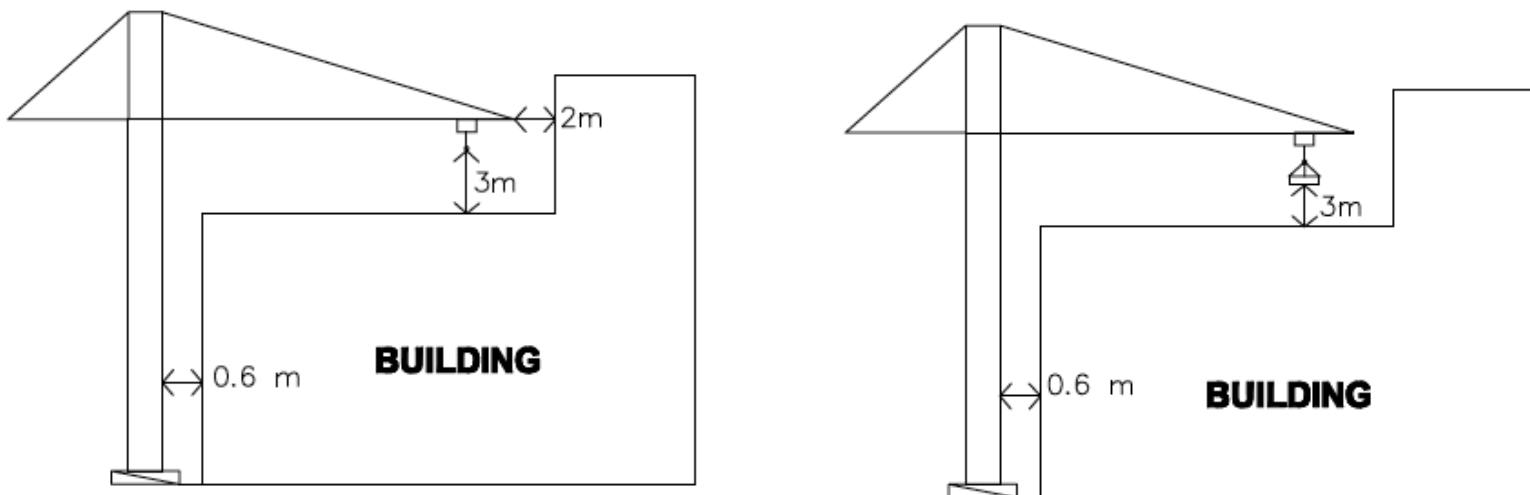

In paragraph 4.1 of the UNE 58-101 92 states: *The minimum clearance for the passage of personnel, among the most prominent parts of the crane and any obstacle is 0.60 m*

wide and 2.50 m high. In case of failure application of this condition will prohibit the access of staff to this area dangerous. (IMAGE 8).

Image 8. Safety distances

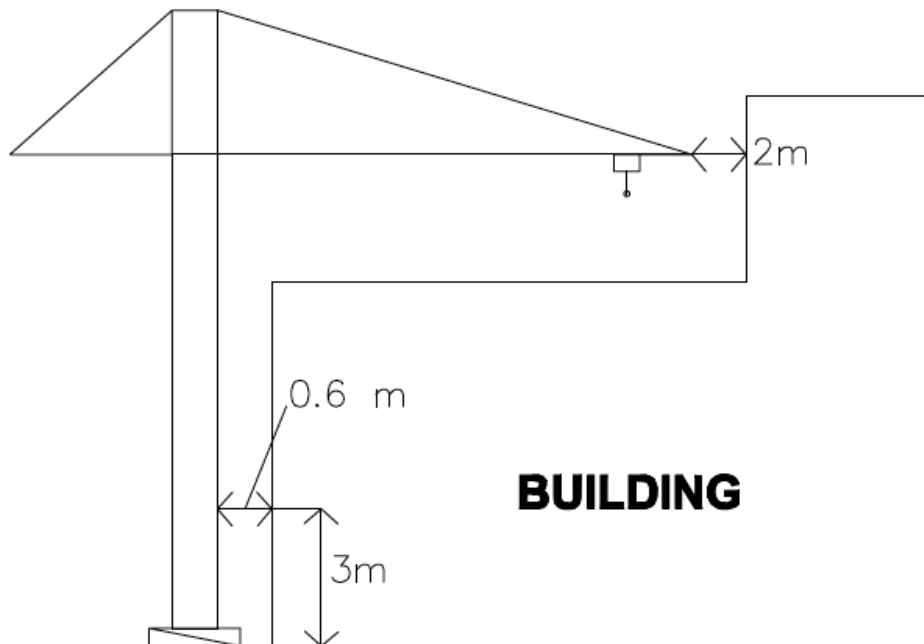

In paragraph 4.1 of the UNE 58-101-92, states: "At no time any part of the crane and its suspended loads, can enter contact with power lines. If these lines are high voltage power should exist between these lines and these items a safe space of 5 m, as minimum, measured in horizontal projection"(IMAGE 9).

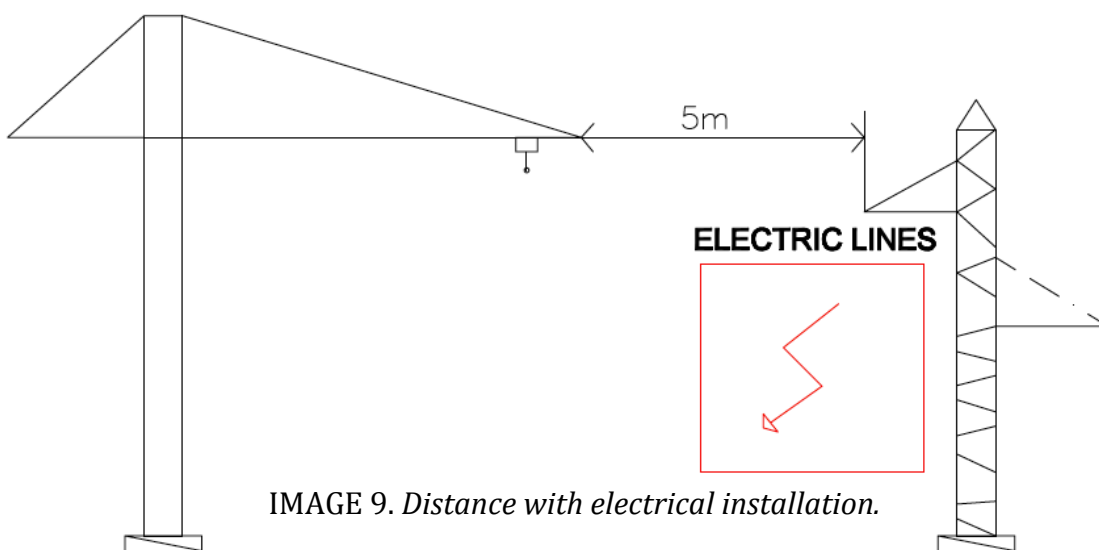

IMAGE 9. Distance with electrical installation.

Below is a picture with the section of the building and the crane installed with fencing and lighting. (IMAGE 10). And one aerial view of the explanatory aerial view of the distances of the crane and different areas of the site.

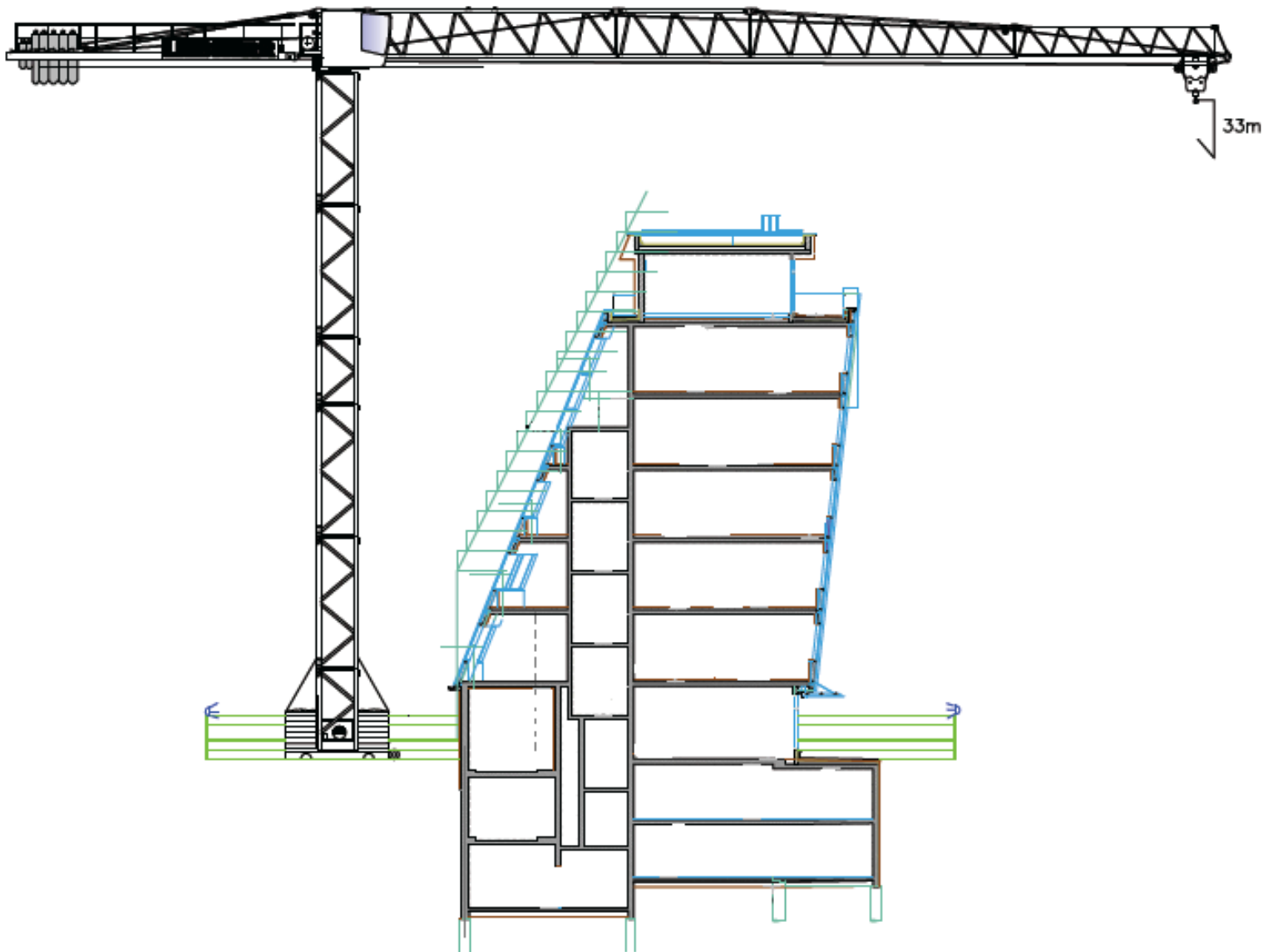
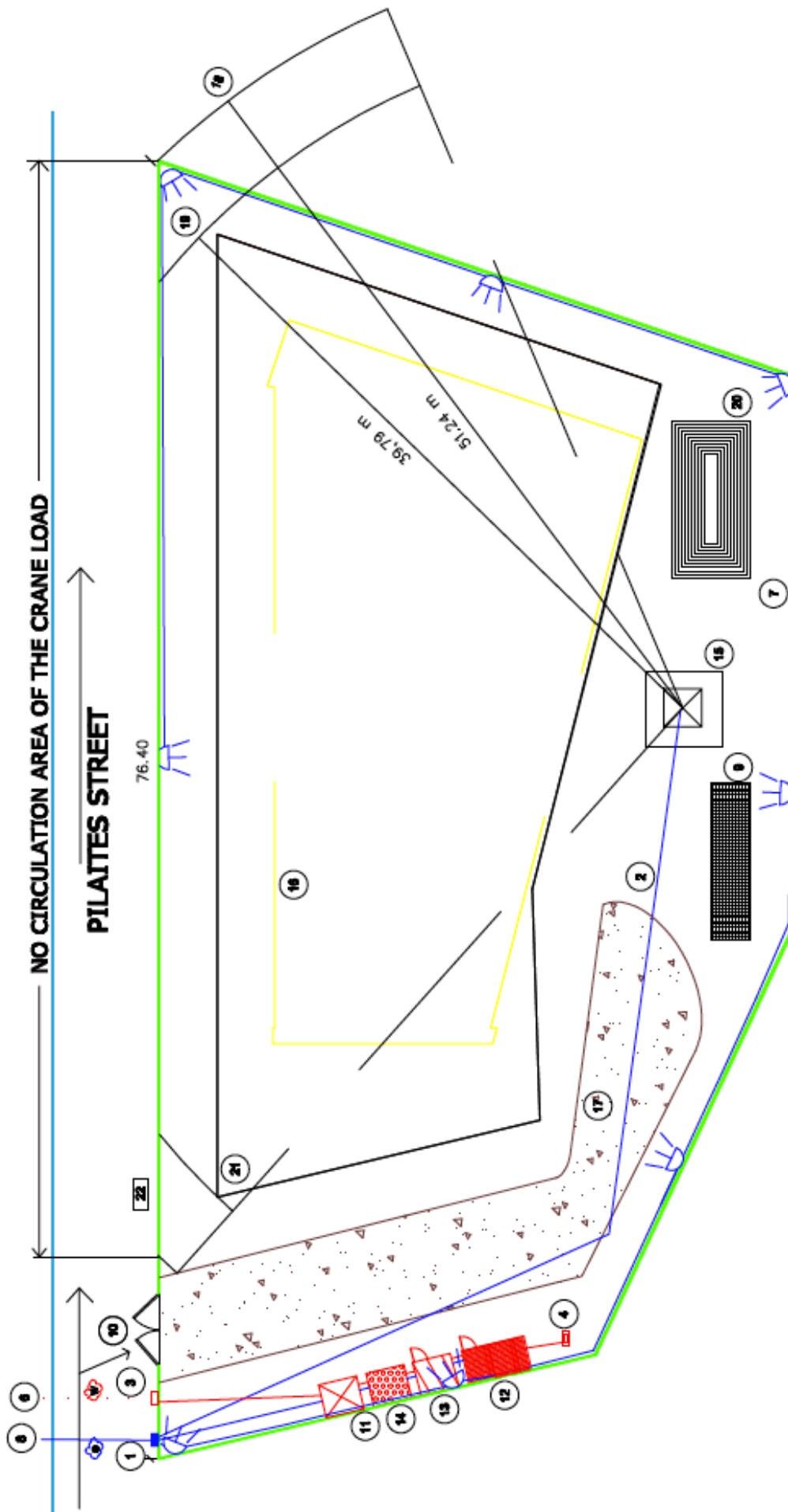

Image 10. Tower Crane and section building view.

Image 11. Tower Crane and building aerial view.



4.1.3 TEMPORARY ROADS TO THE BUILDING PLACE

- There must be a way of access of our site to allow the access to the equipment work to the work field.
- This road must have both directions and must measure 6 meters wide.
- The smallest distance from the road to the warehouse is 1 meter.
- This kind of roads is built to ensure easy driving to the building place and fast work.

4.1.4 TEMPORARY STORAGE BUILDINGS AND SITES

We will need one storage building (5x3x2.20m). And one storage site (9.5 x 4.5) for cover all storage needs. This buildings and sites will be inside our construction site.

4.1.5 TEMPORARY BUILDINGS FOR WORKERS AND MANAGEMENT

To serve the needs of workers and staff will be placed temporary buildings that fulfill different functions.

One Temporary Building for the staff Management (6x3.5x2.2m).Office Temporary building.

The workers will need diferents temporary buildings (5x3x2.2m), two of them as place for resting, eating, etc, and one of them (5x3x2.2m) for using the showers and the toilets.

The number and de dimensions will depend of the quantity of workers.

4.1.6 TEMPORARY ELECTRICITY SUPPLY

The work will be provided with electrical supply to connect the electrical equipment. We will make a temporary installation with general electricity counter connected to the grid. This installation will have different derivations, one for temporary buildings, one for the crane and the various machines that need it. We will used individual 4x16 mm² derivation. (IMAGE 12).

Justification of individual 4x16 mm² derivation:

$$P=\sqrt{3}.u.i.\cos f$$

- P= Power in W.
- u=Voltage in volts for three-phase system as is in the case 400V.
- I= intensity in A.
- cos f = power factor (we considered 0,9).
- I max adm = maximum admissible intensity in A.
- I= 40 A.
- I= 63 A (intensity of the protection element).
- I max adm= 80 A according to rebt itc-bt 19 tabla 1 (Spanish rules. REBT 02).

$I_{ab} < I_n < I_{max adm}$
 (justification that satisfies the individual derivation overload)

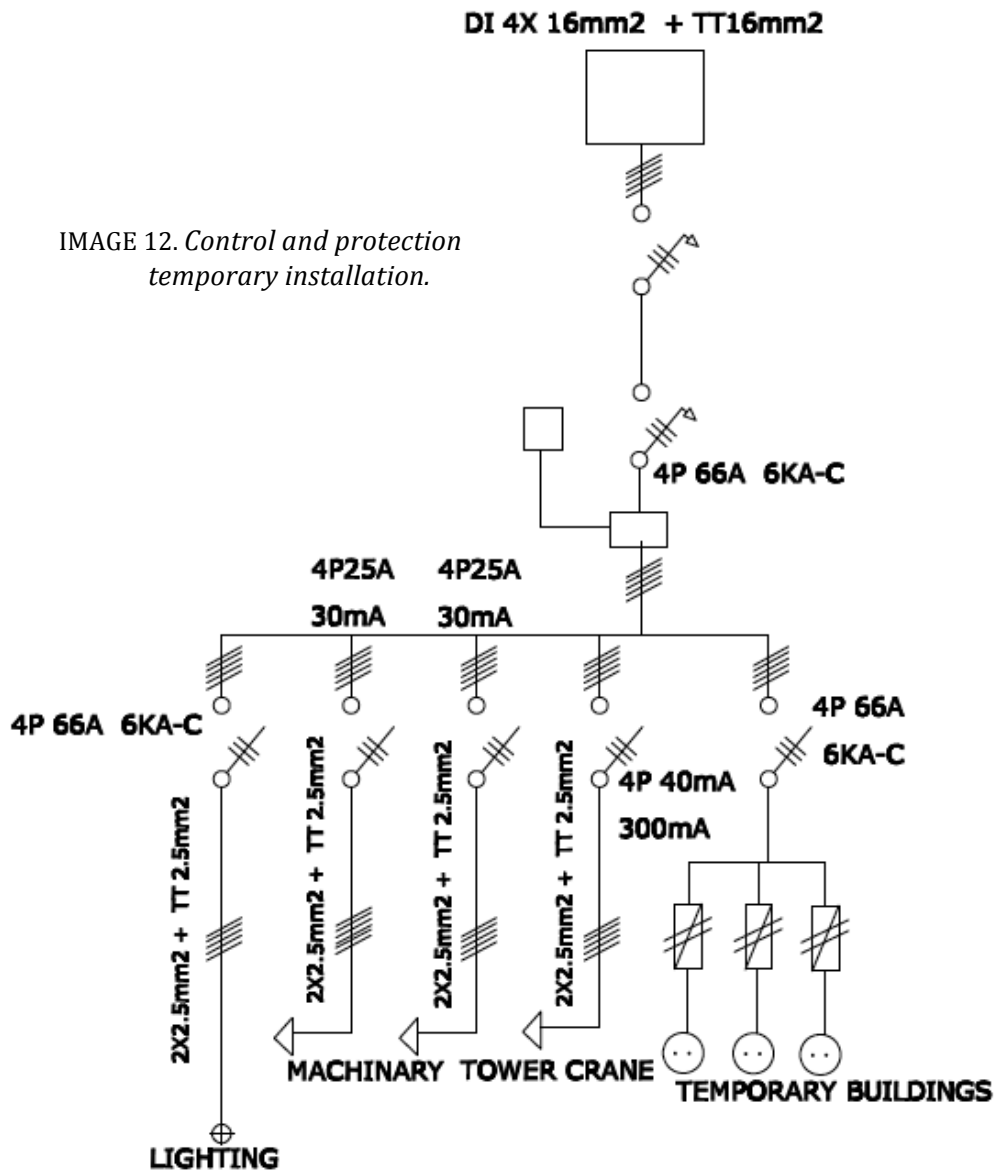

IMAGE 12. Control and protection temporary installation.

4.1.7 CONSTRUCTION SITE LIGHTNING

·Calculation for the lighting of the work place:

N: Number of luminaries required.

E: Average luminance in lux.

fn: Flow Rate of the lamp in lumens.

FU: Factor of use.

FM: maintenance factor.

A: Local Area m².

$$N = \frac{E \times A}{\phi_n \times F_U \times F_{M_i}}$$

·Our data:

N: That we want to calculate

E: 15 lux

fn: 13000

FU : 0.95

FM:1

A: 2329m²

·Data from the lighting area are:

Length: 107.00 m.

Width: 70.00 m.

Height: 4.50 m

INDEX K:

$$K = \frac{l \times b}{h(1 + b)} = \frac{7490}{4.5(107 + 70)} = 9.40$$

With this index, and media with colors for floors and ceiling, and clear to the walls, is a factor in initial use in direct lighting luminarie 1.

The number of lamps required for proper lighting of the premises is:

$$N = \frac{15 \times 2329}{13000 \times 1 \times 0.95} = \text{approximately } 3$$

·The need to place a minimum of 3. But by the way the building and the site will post a minimum of 5.

4.1.8 TEMPORARY WATER SUPPLY

The work will be provided with temporary water supply to have water for the different works that could need and for the temporary buildings. We will make a temporary installation with general water counter connected to the water supply of the city.

This installation will have different elements:

· Accountant, stopcock general, pipe tube 32mm in diameter (Spain standard diameter), wash step and tap. (IMAGE 13).

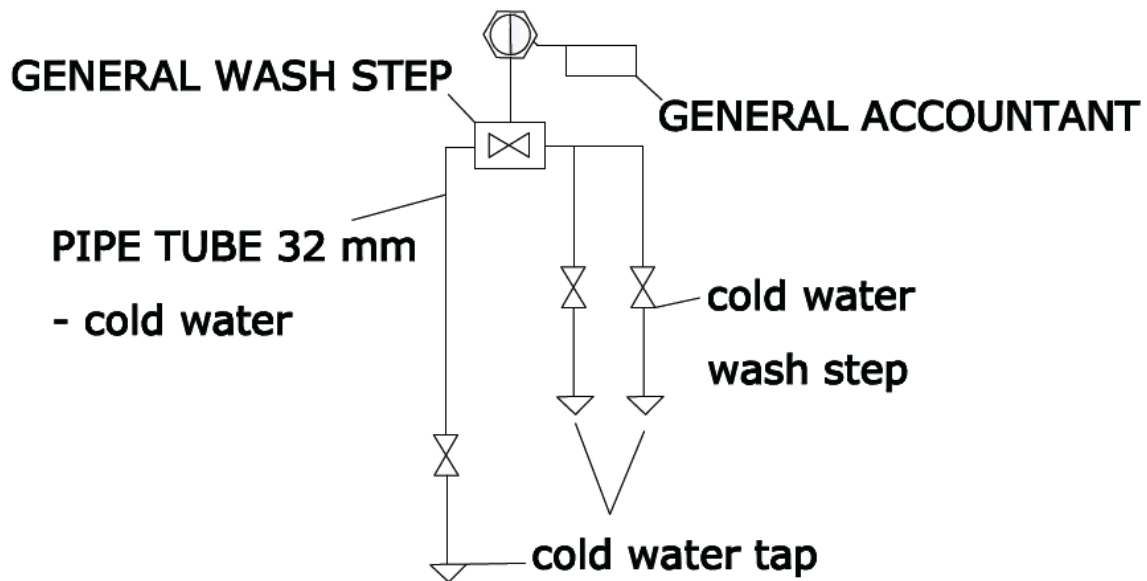

IMAGE 13. Water supply installation.

4.1.9 TEMPORARY SEWERAGE

It will be necessary to have a sewerage system to remove rainwater and wastewater from showers and toilets. This drain will be connected with the general municipal sanitation network. The sewerage system will have a diameter of 200mm.

4.1.10 FENCE OF CONSTRUCTION SITE

The construction fence will protect the entire front parcel, lot or frontage road or existing public or private space or project. The maximum width of the strip of public or private space to be occupied by the fencing work will be of 2.00 meters. In any case, the fence will work a minimum clearway of 0.70 meters measured from the inner line of sidewalk curb most salient point of the fence and, if there were no curb, the minimum step width shall cover the separation or boundary between pedestrian and traffic.

FORMAL CONDITIONS:

The fence will force a minimum height of 2.00 meters measured at any point on the outer face. (*IMAGE 13*).

The crown height is uniform and horizontal projections admitting only to suit the terrain slopes, subject to compliance with the minimum height indicated in the previous section.

Are expressly prohibited ridges and sharp objects, sharp and aggressive that can be incorporated into the fence, both temporarily and permanently.

The outer face of the fence shall not allow the visualization hollow interior or protrusions or holes that allow the stencil. The projections requiring good performance of the fencing construction will be made, wherever possible, by the inner face thereof.

Not be allowed to cover the space of public or private road bounded by the fencing work. It will be mandatory placement of lights signaling pathway hedges occupying public or private

Will be needed $76.40 + 39.60 + 32.9 + 27.6 + 26.59 = 203.09$ m for all the perimeter.

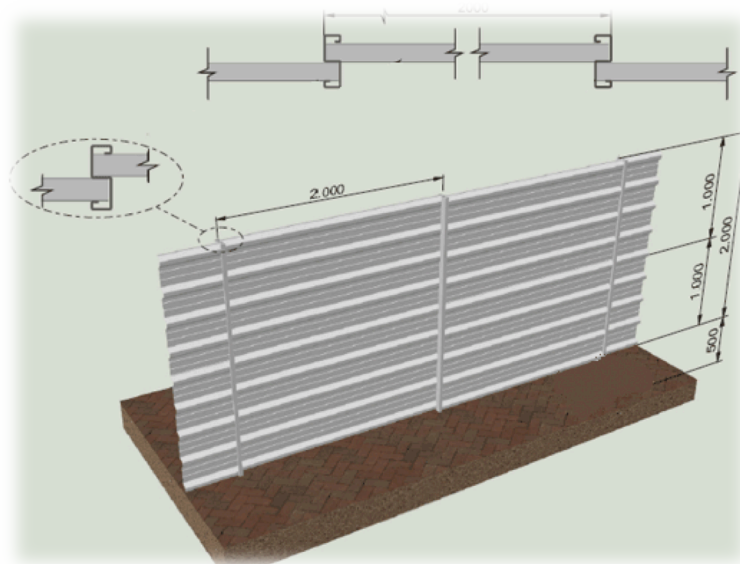

IMAGE 14 .Detail of the fences.

More information: [HTTP://WWW.SACONMA.COM](http://www.saconma.com)

4.1.11 GENERAL REQUERIMENTS OF LABOR SAFETY

This section will evaluate the prevention of hazards and individual protective measures which must be available for the protection of workers.

We can find a list of risks in the works built, the most hazardous are:

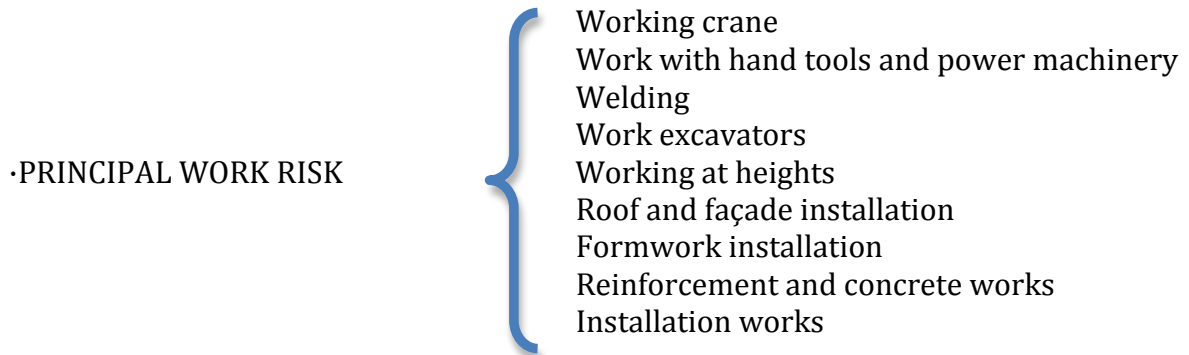

The individual protective elements are:

- Safety helmet: a helmet is expected per worker every six months.
- Safety helmet with screen viewfinder: Expected a helmet every ten workers, since their use is more specific than that of normal helmets.
- Helmet with ear protectors: S provides a helmet with hearing protectors every five workers.
- Safety glasses: glasses are expected every 3 workers.
- Safety glasses oxyacetylene cutting: glasses are planned every 5workers.
- Hearing protection in the form of foam earplugs: Some blocks per worker every two months for those works around loud noises.
- Hearing protection earplug as: Every five workers and nine months.
- Fine dust filter mask: One per employee every two months.
- Utility Gloves: Some gloves per worker every six monthsduration of the work.
- Gloves High resistance to cutting and abrasion: One for every five employees and six months.
- Welder Gloves: A pair of gloves for welder for every ten workers and nine months.

- Dielectric gloves: Two pairs of gloves, since their use is limited to electrical work.
- PVC water Boots: A pair of shoes per worker per nine-month duration of the work.
- PVC Boots BOOTS: A pair of boots for every five workers and nine-month duration of the work.
- Safety Boots: boots per worker every six months duration of the work.
- Pair of boots dielectric: Two pairs of boots for all the work, as the electrical work are often limited.
- Seatbelt lifeline: One for every ten workers and twelve months of the work, to work at height associated with safety lines.
- Vibration Belt: One in three workers and six months.
- Device antiblocaje fall arrest safety belt: Same asbelts for fall arrest.
- Fall arrest system: Same as fall arrest safety belts.
- Strip back injury protection: A worker for nine months of the work.
- Coverall: One per worker every six months.

The most important colective protective elements are:

- Safety net in the first structural floor.
- Safety harness for all the workers.
- Perimeter Rawlings on each floor of the work.
- Holes in the floor must be convered with nets.
- Walkways and ramps at the same or differrent level.
- Working platforms: for working at height.

4.1.12 REQUIREMENTS OF ENVIRONMENTAL PROTECTION:

We must have planned the management of waste may be generated during the execution of the work.

There must be a previous study that generate waste, classified according to their nature and dangerousness. And check which can be recycled and which not.

This will prepare a plan of construction waste that we meet. When finished construcion waste must no exist on the site.

During the execution of the work we have different containers for separate waste, and the appointment of a person who controlled the management.

4.1.13 REQUIREMENTS OF FIRE PROTECTION

Durante la construcción deberemos tener en cuenta el riesgo de incendio y los daños que esto puede provocar. Deberemos hacer un estudio que los riesgos y establecer medidas de seguridad contra incendios y medios de protección y sofocación de incendios. In the site will be in a visible and accessible place should be a panel with inventory:

EXTINCTIONS EQUIPMENT

- Two buckets
- Two axes
- Two crowbars
- Ladders, hook 0.5 of sand box
- Two fire extinguishers

4.2 WORKFORCE

4.2.1 DISTRIBUTION OF WORKFORCE

In the table we can see the quantity of workers per month that we will need for all the works. (IMAGE 15).

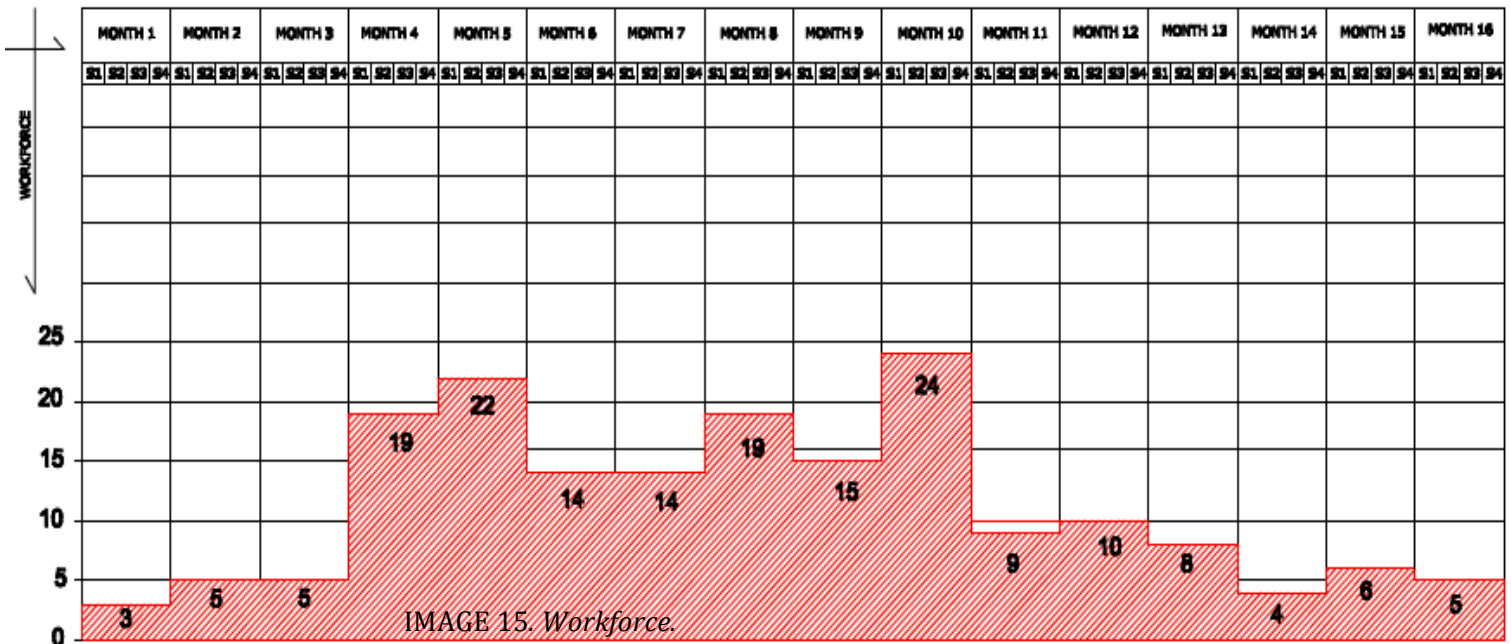

4.2.2 MACHINERY AND MATERIALS.

In the following tables we can see the quantity of machinery and materials per month that we will need for all the works. (IMAGE 65 and IMAGE 17).

IMAGE 16. Materials.

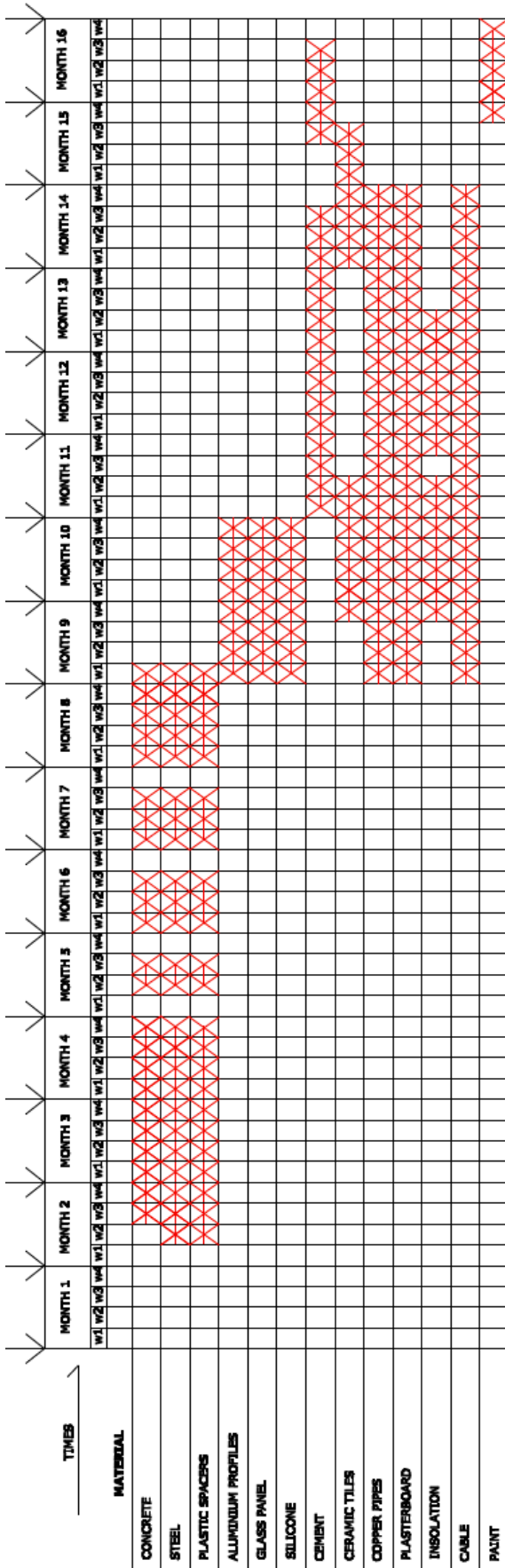
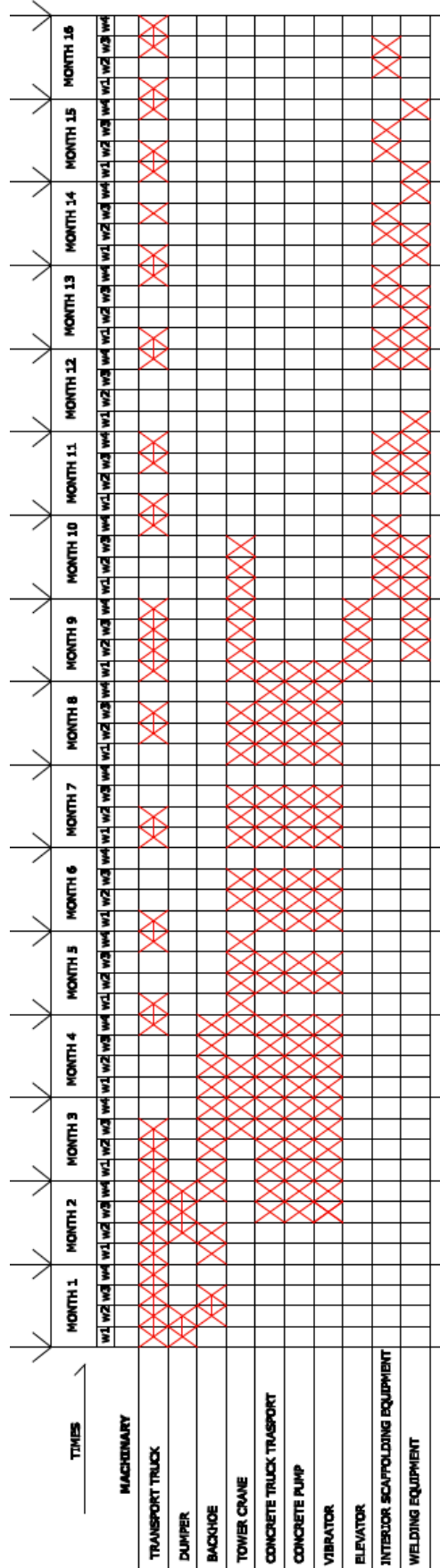

IMAGE 16. Machinery.



BIBLIOGRAPHY:**-WEB PAGES:**

Valencian data base for price calculations:

<http://www.five.es/basedatos/Visualizador/Base12/index.htm>

Forum of architecture: <http://www.soloarquitectura.com/foros/forum.php>

Construpedia, definitions of works:

<http://www.construmatica.com/construpedia/Portada>

Diferents university pages:

www.upv.es

www.vgtu.es

Technical code (Spanish normative): <http://www.codigotecnico.org/web/>

Temporary buildings www.remsa.net

Fences: [HTTP://WWW.SACONMA.COM](http://WWW.SACONMA.COM)

For the crane and pump: http://www.liebherr.com/es-ES/default_lh.wfw

For the curtain wall: <http://www.alusink.com/pdf/MUR-50.pdf>

-BOOKS:

1- Books and notes from Politechnic University of Valencia.

2-Brotons books:

3-Construcción de estructuras. Hormigón armado : adaptado a las instrucciones EHE, EFHE, NCSE-02 y CTE. Urbán Brotóns, Pascual
San Vicente, Alicante: Club Universitario , 2009

4-Construcción de estructuras de hormigón armado

Urbán Brotóns, Pascual

Alicante: Club Universitario , 1999

5- Apuntes de construcción de estructuras de hormigón armado / Pascual Urbán Brotóns.

San Vicente (Alicante): (Imp. Gamma), D.L. 1999

6- EHE Spanish normative.

