

## Casa Nautilus Solar – Organic contemporary Architecture based on Vernacular Heritage

Petra Jebens-Zirkel Imm<sup>1</sup>, Alfred Johann Zirkel Zirkel<sup>2</sup>

<sup>1</sup>IEB, Oncins, Aragón, Spain, [petra.jebens@gmail.com](mailto:petra.jebens@gmail.com); <sup>2</sup>[alfred.zirkel@gmail.com](mailto:alfred.zirkel@gmail.com)

**Topic:** T1.4. Sustainability of vernacular architecture

### Abstract

*The common ground between vernacular architecture and contemporary ecological organic architecture (Ecohabitar, 2011pp21) emerges from regional activity adapted to local climate while using natural materials from the surrounding area. A healthy environment is created through the principles of Habitat Biology, which is based on the empirical wisdom of past generations. These actions were, and still are, highly sustainable and regenerative through a “closed circuit” of resources without any damage to the ecosystem. We propose a family home with building biology criteria and bio-climatic design, based on the use of high quality building materials: load bearing walls of sun-dried earth blocks with hemp insulation, earth and lime renders with natural paints, a timber structure and an organic green roof, working together to create healthy, pleasant spaces. This house sets the stage for a life project in a rural setting, focused on a farming and livestock initiative. Independence from the water and energy grids is made possible by rainwater harvesting, a well, a compost toilet, grey water treatment with aquatic plants and the use of renewable energy with simple technology (photovoltaic panels, thermal panels and a heavy Kachelofen-type wood burning stove). The design and form are adapted to the agricultural landscape and emerge from the interior and exterior needs of its inhabitants: solar orientation, exposed construction systems, the proportions of the golden section and appropriate interior and exterior colours.*

**Keywords:** building biology, organic architecture, green roof

### 1. Introduction

Our client’s objective is to create a respectful life project in the remote rural setting of the Sobrarbe region in Huesca, Aragon. Self-sufficient and off-grid, using sustainable building materials and focusing the project around a farming and livestock business, which includes the farmyard, an energy systems structure and a renovated agricultural barn.

A carefully created micro-climate provides the interior and exterior comfort required, in terms of temperature range, humidity, colour, plant-life, natural light and controlled artificial light. Nature is always the basis (Cook,1996).



Fig. 1. Main facade from the southeast

The project meets the standards of the 25 rules of building biology ([www.baubiologie.es/25-pautas/](http://www.baubiologie.es/25-pautas/)) wherever possible (IBN-IEB).

The used materials are:

- Load bearing walls with clay and hemp fibre sun-dried bricks
- Lime mortars and renders (avoiding cement)
- Minimum of reinforced concrete: only for foundations and ring beams
- Mud render for interiors
- Timber for the horizontal structure and all carpentry treated with natural oils and resins
- Natural fibres and granulates for insulation
- Carefully chosen paints: natural products with no added synthetics or VOCs (Volatile organic compounds)
- Tadelakt instead of tiling
- Terracotta tiles treated with natural oils and resins
- Polypropylene (PP) and polythene (PE) tubes with no added PVC or halogen products

The four buildings form a small survival nucleus: the house, a structure for the energy systems (car porch), which permit energy independence, the agricultural stable for the livestock and the renovated barn – along with the water well, the reed bed and the planting of a variety of trees and a vegetable garden.

The built area of the house is 223 m<sup>2</sup> (including 34 m<sup>2</sup> of garage and 30 m<sup>2</sup> of conservatory) and 118 m<sup>2</sup> of outbuildings (car porch, stable and renovated barn).



Fig. 2. Main living aerea

## 2. Good intent and participation of the owner

Teamwork has been a key element right from the start, with a high level of collaboration and good intent with special focus on achieving close harmony at every stage of the process: not only in the development of the project between architect and client, and communication with the local authorities, but also with the different trades throughout the building process.



Fig. 3. Rural aerea: casa Nautilus and energy systems structure

The owner explains:

“This is a two headed project. On one hand is the desire to finally have my ‘farm’, made up of a home and an integrated livestock business, brought about by combining age-old local techniques with more recent ideas on energy efficiency, zero waste, sustainability and integral management. On the other hand, given my experience in the tourism sector, there is the challenge of promoting the ‘farm’ as a tourist attraction with two aims: purely for tourism (truffle-tourism, animals and farm jobs) and raising social awareness of this integrated way of life within our environment, while always looking for the correlation between our different needs and the resources that the earth provides. In this way we can work towards a rational use of natural resources, which, as society is starting to understand, are limited and ever more scarce. This is basically about applying Social Business Responsibility to the tourism sector and to livestock farming. That's why the house, as well as being totally integrated into the landscape, is self-sufficient in terms of water and energy. The only waste it produces are plastics, glass and paper, while organic material is composted and grey water is processed by the reed-bed. In addition, we'll try to ensure that our crops

as well as our livestock come from 100% local species; from local holly oak to latón pork, olive trees, fruit trees and horticultural seeds in a totally organic way”.

### 3. Sensitive architectural design

The form of this single storey house arises as a sensitive response to the land that it sits in. Its geometry, free of straight lines, and with gentle movements, adapts comfortably and in harmony to the natural forms that surround it (Van de Ree, 2001). The main spaces in the building are facing south where it has a conservatory for the capture of passive solar energy. The impressive views to the north are taken into account, as well as protection from the cold northerly winds. There is a central skylight which illuminates all the rooms. The compact volume of the house results in savings on building materials and energy.

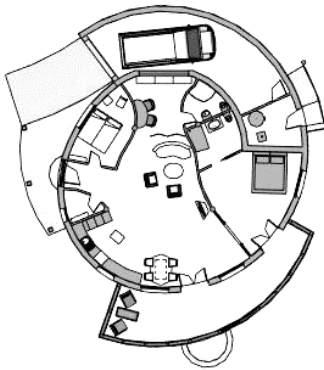

Fig. 4. Ground Floor

The house's floor design is like a spiral, following the path of the sun, with a large south-facing living room/kitchen/dining room leading onto the en-suite master bedroom, the guest room, the bathroom, the larder and the conservatory. This glazed structure, thanks to its position and shape, is exposed to a large part of the sun's journey from east to west with notable solar energy benefits. The heat passes through the interior windows and doors into the living room and bedroom. In summer the glass-roof is covered with an awning, and by opening all the windows it is transformed into a shady porch area that cools the south facade.



Fig. 5. Conservatory

The main entrance to the house is on the west facade giving direct access to the vegetable garden. In addition, there is a vehicle access from the track. The garage-workshop along with the energy systems plant room acts as a barrier against the cold northerly winds.

### 4. Simple construction

#### 4.1. Ground floor in contact with the earth

Once the earth had been cleared of vegetation and compacted, a 20 cm bed of gravel for drainage was laid. Then a double layer of polypropylene was applied, and a 15 cm slab of “bio-concrete” composed of hydraulic lime, sand, gravel and polypropylene fibres to prevent shrinkage. On top of this a 10 cm layer of insulating screed made up of a wet mix of natural cork granules, sand and hydraulic lime was applied. The floor was finished with terracotta tiles laid with a lime mortar.



Fig. 6. Fireplace and Skylight in Living Area

## 4.2. Exposed structure

Use of reinforced concrete has been kept to a minimum, only used for foundations and ring beams. Continuous reinforced concrete foundations were topped with a rubber damp proof course (EPDM). Then a 30 cm load bearing wall was built using sun-dried bricks of earth, lime and hemp fibre (“Cannabric”) up to the height of the concrete ring beam (Canapalea, 2018). The ring beam's exterior was insulated with 3 cm natural cork boards to avoid cold bridges.



Fig. 7. Skylight, north-window and visible clay bricks

The primary structural beams are supported by four central timber posts. The basic timber framework supporting the building is exposed so that the roof structure is clearly visible, thus contributing to the interior aesthetics of the house.



Fig. 8. View from Southwest

## 4.3. Healthy building materials

Natural building materials were selected because of their minimal processing and therefore low environmental impact and low carbon footprint. Dubious chemical products were avoided and technical data was rigorously examined for all materials used on the buildings. The materials used have a good balance between

hygroscopicity, humidity regulation and thermal mass, ensuring optimum air quality. The main elements used are earth, wood and lime.

Natural cork insulation was sourced and ample layers were applied to the floors, the exterior walls and the roof, leading to a significant reduction in energy consumption.

Cannabric blocks were also used for the interior partition walls, with a width of 9.5 cm and a height of 2.30 m, leaving the roof structure exposed.

All windows and doors were made from timber and the exterior double glazing was specified at 4/16/4. The conservatory exterior windows have single glazing while the roof is glazed with reinforced laminated glass.

The interiors are rendered with various shades of earth based mortar. Instead of tiles, tadelakt is used as a finish on the kitchen surfaces and splash areas, as well as in the showers and bathrooms: an artisan technique using lime and striking natural pigments with a surface texture that is very pleasant to the touch.

The exterior walls are rendered with several layers of slaked lime mortar and finished with silicate paints. All paints were chosen without added synthetics or VOC's. Natural oils and resins were used on the terracotta tiles and woodwork.

## 4.4. An earth roof – a natural “sunhat”

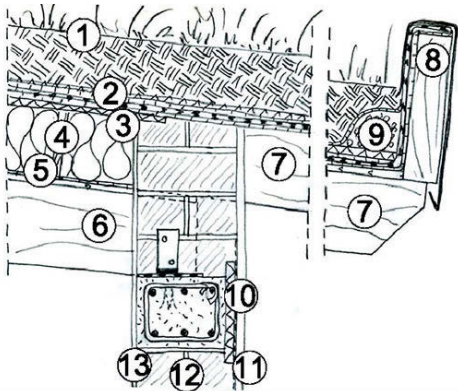

Fig. 9. Green Roof from the North

An organic green roof acts as a protective sunhat. The plant life that covers it is an ecological solution and has considerable economic advantages (Minke, 2005):



- the plants produce oxygen and absorb CO<sub>2</sub>
- it compensates for the loss of the original ground space the house was built on
- it absorbs particles from pollution and dirt
- it prevents overheating in summer and reduces extreme temperature and humidity changes, in dry season it acts as thermal and generally acoustic insulation
- it will last nearly indefinitely.



- 1) 15 cm of earth, vegetation of local species
- 2) Textile underlining, rubber EPDM, PE drainage membrane, anti-root textile
- 3) Wood fiber panels (2.2cm)
- 4) 20cm boards, natural cork granules
- 5) Tongue and groove boards (2.2cm), kraft paper
- 6) Timber roof beams fixed on concrete ring beams above EPDM
- 7) Roof beams for overhang
- 8) Timber frame with metal sheet protection
- 9) Gravel drainage
- 10) Cork plate, PP grid
- 11) Exterior lime render
- 12) Walls of sun-dried earth blocks with hemp insulation ("cannabric")
- 13) Interior clay render

Fig. 10. Constructive section of the green roof

In this case it was built around a central skylight. The roof opens out to the south and drops steeply to the north, where there is an arched dormer window. As already mentioned the interior timber structure is visible - in the shape of a radiating mandala - and can be seen from all the rooms. Tongue and groove boards were laid on top of the structural timber beams, followed by kraft paper membrane and a 20 cm layer of a wet insulation mix of natural cork granules and

a small amount of sand and lime. Textile underlining and rubber EPDM were put under a polyethylene studded drainage membrane with an anti-root textile lining followed by 15 cm of earth. Local species like lilies and sempervivums were planted, avoiding any need for irrigation.

## 5. Independent water treatment in a closed circuit

Water self-sufficiency has been achieved with several important water capturing elements: a tank for harvesting rain water, a well, and also natural water saving and water purification systems. Rain water and well water are used for sanitary water; both have their own filter systems.

### 5.1. Compost toilet

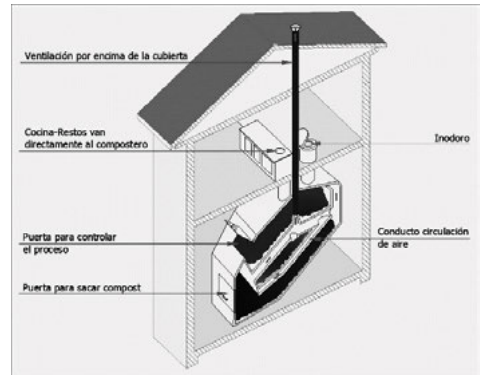

Fig. 11. Function of a compost toilet

Water use is reduced through the use of a clivus multrum type compost toilet which also produces natural fertilizer. This system has been invented in 1930 by the Swede R.Lindstroem. It is a dry system: water is not used, so there is no need to treat it. Organic material decomposes into compost which can be used as fertilizer on fruit trees. The system comprises a toilet bowl in each of the two bathrooms with two wide, straight tubes feeding into a collecting tank in the garage where the compost is harvested. A perfect environment for micro-organisms is created inside the tank with continuous air ventilation provided by a chimney that goes through the roof. With the chimney effect- the warm air in the tank rises – and with the help of a ventilator, a constant

upward flow of air is guaranteed, avoiding bad smells on opening the toilet lid. The collecting tank is insulated to maintain an optimum temperature for the biological process in the interior. With a base inclination of 30°, the contents slowly slides down and forward so that only decomposed material reaches the front of the tank where the compost is harvested. As the material is dry, only 0,02 m<sup>3</sup> (2 buckets of 10lt) of compost is produced per person per year.

## 5.2. On-site waste-water treatment with a reed bed

Grey waste-water is treated with a reed bed system. These aquatic plant systems have existed in several guises since their invention in Germany in 1973 and are being used for villages of up to 120,000 people as well as for family dwellings. Efficiency studies and water testing have demonstrated them to be more than satisfactory. In 1995 the German Ministry of Environment completed an eight-year study about the functioning of 20 different types and sizes of reed bed water treatment systems for black water. The results showed that the effects of this treatment and its hygiene conditions are far superior to those of conventional water treatment systems. Treatment of organic material was more than 95% and it was up to 99% for nutrient substances. The biochemical DBO5 demand was 5 mg/l and the biochemical DQO oxygen demand was up to 80 mg/l.

## 6. Self-sufficiency with efficient systems



Fig. 12. Kachelofen built out of Bricks

Most of the heating needs are met by the considerable amount of passive solar heat coming from the glazed conservatory. As a back-up, at night or on cloudy days, there is a heavy brick build wood-burning stove (Kachelofen), plastered with clay, providing radiation heat to the main space. The smoke passes along several metres of chimney through two bathrooms and the bedroom, heating them on its way while only minimal amounts of fire wood are used. Additionally, provision has been made for the installation of a biomass burner for under floor heating, however this has not been necessary during the first few winters.

In summer, with natural nocturnal ventilation, there is little cooling requirement. This is due to the high level of insulation and moreover, the thermal inertia provided by the floors and walls.

Hot water is produced all year round by two thermal solar panels with a total area of 4 m<sup>2</sup>, installed on the roof of the car porch.

Electricity is provided by an off grid 5 kw photovoltaic system, also installed on the same roof of the car porch where the batteries, inverter and generator are stored.

All cables and tubes are PP or PE, avoiding halogen materials and PVC.

## 7. Conclusions

Organical architecture, together with the sustainable aspects of Building Biology (Baubiologie), is deep-rooted in vernacular heritage.

In this contemporary architectural project the three main principals of vernacular heritage are fulfilled:

- Environmental: respectation of nature (e.g. materials), appropriately situated (e.g. integration), reduction of pollution and waste materials, health quality (e.g. ecological materials), reduction of natural hazards effects (e.g. compact form).
- Socio-Cultural: protection of cultural landscape (e.g. green roof), transfer of

construction cultures (e.g. load bearing walls), enhance creativity (e.g. organic design).

- Socio-Economic: support of autonomy (e.g. off grid systems), promotion of local activities (e.g. farming), extension of building's lifetime (e.g. valuable materials and constructive details), saving of resources (e.g. water and energy).

Casa Nautilus is a self-sufficient house and requires active participation on the part of its inhabitants in terms of understanding the workings and maintenance of its systems. Our client has been highly involved in both the development and the construction phases of the building and as a result is familiar with every detail of the buildings as well as the off grid systems and their maintenance. He therefore has no need to depend completely on tradesmen and specialists which is an important step on the path to independence and self-sufficiency.

Also the performance of the building's passive systems relies on the active participation of its inhabitants in order to achieve appropriate general and bio-climatic conditions: opening and closing of windows, awnings and shutters; harvesting compost from the dry toilet etc. The owner understands these needs and is prepared to live in his house in harmony with the different seasons of the year.



Fig. 13. View from the Living Aerea to the Conservatory\*

Individual perception of the healthy environment, comfort and well-being is processed by the senses: pleasant smells, lively colours whose shades change in different light, shapes that are easy on the eye and surfaces that are pleasant to the touch - and with a high level of thermal comfort.

This initiative, a life project in a rural area, serves as a prime example within the framework of cultural regeneration (Wahl, 2020) and as a format to be followed: an example of a home that has opted for an innovative organic design integrated into its surroundings, healthy recyclable materials, energy and water self-sufficiency – in effect, a profound commitment to the rural area which it forms a part of.



Fig. 14. Location of the life project

## References

- Ecohabitar (2011). *Guia del Hábitat Ecológico*. Ecohabitar Ed. Olba. 21 pp.
- Cook, Jeffrey (1996). *Seeking Structure from Nature – The Organic Architecture of Hungary*. Birkhäuser Ed. Basel.
- Various authors. *Masters in Building Biology IBN – IEB* www.baubiologie.es
- Van der Ree, Pieter (2001). *Organische Architektur*. Verlag Freies Geistesleben Ed. Stuttgart.
- Canapalea (2018). *Construir con Canamo*. Autoedicion (Erasmus).
- Minke, Gernot (2005). *Techos verdes*, Ecohabitar. Ecohabitar Ed. Olba.
- Wahl, Daniel Christian (2020). *Diseanado Culturas Regenerativas*. Ecohabitar Ed. Olba.

\* All photos: Xavier D'Arquer Blanc, Doble Estudio.