



**KTH Industrial Engineering  
and Management**

DEGREE PROJECT IN SUSTAINABLE ENERGY ENGINEERING,  
SECOND CYCLE, 30 CREDITS  
STOCKHOLM, SWEDEN 2020

# **Techno-economic analysis of a hybrid CSP-PV plant including electrical batteries**

**Maria Ruiz Garrido**

**KTH ROYAL INSTITUTE OF TECHNOLOGY  
SCHOOL OF INDUSTRIAL ENGINEERING AND MANAGEMENT**



**KTH Industrial Engineering  
and Management**

**Master of Science Thesis  
Department of Energy Technology  
KTH 2020**

**Techno-economic analysis of hybrid particle CSP-PV  
plant including electrical batteries**

TRITA- ITM-EX 2022:564

Maria Ruiz Garrido

Approved	Examiner Laumert Björn	Supervisor Silvia Trevisan, Salvatore Guccione
	Industrial Supervisor -	Contact person David Alfonso Solar

## Abstract

Hybridization of Concentrating Solar Power (CSP) with Photovoltaic (PV) has gained market traction, and interest provided the rapid decline of costs in PV installations, the need for storage in the system, and the geographical conditions compatibility for both technologies. Depending on the hybridization strategy, the costs of a hybrid CSP-PV facility could be 25% lower than an equivalent-sized CSP-only plant.

This thesis has two goals: firstly, to propose and model two concentrating solar plant layouts hybridized with PV panels; secondly, to evaluate the techno-economic performance of the proposed layouts to perform a comparative quantitative analysis with other CSP solutions. The starting point of this thesis is an air-driven supercritical CO<sub>2</sub> Brayton power cycle for a concentrating solar power plant, with a packed bed as thermal energy storage and a molten salt receiver.

This project attempts to improve on this design by using an air receiver, which is intended to achieve a higher receiver outlet temperature and be more environmentally friendly, and to add photovoltaic panels to assist in power generation, as they are more economical and thus try to reduce the Levelized cost of energy (LCOE) of the starting plant.

A comparison is made between the new layout and the same layout by adding electric batteries to the photovoltaic panels for short periods without solar radiation. Both layouts are modeled and optimized through Python and then compared with the initial design.

## **Nomenclature**

### **Abbreviations**

*CSP*: Concentrated Solar Power

*PV*: Photovoltaic

*TES*: Thermal Energy Storage

*HTR*: High Temperature Recuperator

*LTR*: Low Temperature Recuperator

*MC*: Main Compressor

*RC*: Recompressor

*SM*: Solar Multiple

*BESS*: Battery Energy Storage System

*DNI*: Direct Normal Irradiance

*GHI*: Global Horizontal Irradiance

*LCOE*: Level Cost of Electricity

*OPEX*: Operational Expenditures

*CAPEX*: Capital Exenditures

*CF*: Capacity factor

*KPI*: Key Performance Indicator

*GEN*: Generator

*EH*: Electrical Heater

*HPT*: High Pressure Turbine

*LPT*: Low Pressure Turbine

*SOC*: State of Charge

*PB*: Power block

## Symbols

$T_c$ : Cold Temperature [°C]

$T_h$ : Hot Temperature [°C]

$T_{out}$ : Outlet Temperature [°C]

$T_{maxTES}$ : Maximum temperature thermal Energy Storage [°C]

$T_{minTES}$ : Minimum temperature thermal Energy Storage [°C]

$V_{TES}$ : Volume TES [m<sup>3</sup>]

$T_{cut}$ : Cut-off temperature

$E_{TESmax}$ : Maximum Energy thermal Energy Storage [Wh]

$N_{TES}$ : Number of Thermal Energy Storage [-]

$\eta$ : Efficiency [%]

$C_{helio}$ : Heliostat Specific Cost [\$/m<sup>2</sup>]

$A_{helio}$ : Heliostat surface [m<sup>2</sup>]

$C_{land}$ : Land cost [\$/m<sup>2</sup>]

$C_{tower}$ : Tower specific cost [\$/m<sup>2</sup>]

$H_{tower,Ref}$ : Tower reference height [m]

$C_{Rec,1}$ : Receiver reference costs [\$/°C]

$C_{Rec,2}$ : Number of Thermal Energy Storage [\$/°C]

$C_{Air,C,1}$ : Compressor reference costs [\$]

$C_{air,ref}$ : Reference air mass flow rate [Kg/s]

$\eta_{ref}$ : Reference compressor efficiency [-]

$C_y$ : Operational costs incurred in year  $y$  [\$/year]

$CRF_y$ : Capital recovery factor in year  $y$  [\$/year]

$G_y$ : Generation of electricity in year  $y$   
[ $W/year$ ]

$y$ : years of plant of life [-]

$r$ : required rate of return period [-]

# Contents

<b>1</b>	<b>Introduction</b>	<b>9</b>
1.1	Aim Objectives . . . . .	10
1.2	Thesis Structure . . . . .	10
<b>2</b>	<b>Literature Review</b>	<b>11</b>
2.1	Solar energy . . . . .	11
2.2	Concentrated Solar Power (CSP) . . . . .	11
2.2.1	Main components of CSP system . . . . .	12
2.3	Photovoltaic . . . . .	17
2.3.1	Concepts and definitions . . . . .	17
2.3.2	Electric batteries for PV . . . . .	18
2.4	Hybrid . . . . .	19
<b>3</b>	<b>Methodology and modelling of the plant</b>	<b>20</b>
3.1	Methodology . . . . .	20
3.2	Description of the model . . . . .	21
3.3	Control strategy . . . . .	22
3.4	Modelling the main parts . . . . .	23
3.4.1	Receiver . . . . .	23
3.4.2	Packed bed TES . . . . .	24
3.4.3	PV . . . . .	25
3.5	Main inputs . . . . .	25
3.6	Key Performance Indicators (KPIs) . . . . .	26
3.7	Economic Model . . . . .	27
3.8	Base Case: Ourzazate . . . . .	29
<b>4</b>	<b>Results</b>	<b>31</b>
4.1	Base model . . . . .	31
4.2	Plant with BESS . . . . .	33
4.3	Optimization . . . . .	36
<b>5</b>	<b>Conclusions</b>	<b>39</b>



## List of Figures

1	Global goals for a sustainable development [2]	9
2	Total energy resources. [4]	11
3	Leading countries in CSP in 2020 [6]	12
4	Main components of CSP system	12
5	Types of CSP plants [7]	13
6	Volumetric effect	14
7	CSP dispatchability [11]	15
8	Schematic of a packed-bed thermal store. Hot gas enters at the top at temperature $T_h$ and exits from the bottom at temperature $T_c$ . [1]	16
9	Performance PV panels [16]	18
10	Horizontal Global Irradiance [16]	18
11	Evolution LCOE CSP and PV from 2010 to 2050 [23]	19
12	Methodology	20
13	Layout system base case	21
14	Layout system with electric batteries	22
15	Control strategy	23
16	Receiver efficiency	23
17	Outlet temperature TES	24
18	TES coefficients	24
19	PV inputs	25
20	Main inputs	26
21	Ourzazate location	29
22	DNI per month	29
23	Plant performance during a week in summer	31
24	Plant performance during a week in winter	31
25	CAPEX and OPEX costs	32
26	CAPEX costs	33
27	Performance of the plant during a week in winter	34
28	Performance of the plant during a week in summer	34
29		35
30		35
31		36
32	Influence of the hours of the TES in the LCOE	37
33	Influence of the SM in the LCOE	37
34	Costs of BESS	38

## List of Tables

1	Specific costs for TES materials . . . . .	28
2	Reference costs and exponent for main components in the sC02 power cycle . . . .	28
3	Reference costs for main components in the solar field . . . . .	28
4	KPIs base case . . . . .	33
5	KPIs BESS . . . . .	36
6	Boundaries optimization . . . . .	37
7	Design variables optimized . . . . .	38
8	KPIs optimization . . . . .	38
9	All KPIs . . . . .	39

# 1 Introduction

During the last century, human activities such as the burning of fossil fuels like coal and oil, and to a lesser extent activities such as land clearing for agriculture, industry and other human activities have increased CO<sub>2</sub> emissions into the atmosphere. Since 1750, modern civilisation with its industrial activities has increased CO<sub>2</sub> emissions by 50%.

The predictions made by climate scientists have already begun to be realised: glaciers are melting, sea levels are rising, sea temperatures are rising, heat waves are becoming more intense. If the amount of CO<sub>2</sub> emissions is not radically changed, these predictions will continue and the climate damage will intensify. Climate change has gone from being a problem of the future to a problem of great importance today.

We all know that we face major challenges in today's world: poverty, hunger, inequality, and climate change are just some of the issues we must urgently address. Seventeen global targets have been set as shown in the next figure. The most relevant to this work is the goal of achieving clean and competitively priced energy. [2]



Figure 1: Global goals for a sustainable development [2]

In recent years, electricity generation from renewable energies has been growing more and more. According to the Paris treaty, it is fundamental to move toward the energy transition and thus achieve zero emissions by 2050.

Among all renewable energy sources, one of the most important and fastest-growing in recent years is solar energy, i.e., obtaining power directly from the sun.

There are two leading technologies, photovoltaic panels and concentrated solar power.

Photovoltaic panels, also known as solar cells, are electronic devices that directly convert solar energy into electricity. They are used for small-scale and large-scale applications (residential and commercial buildings). In recent years their price has decreased so much that they have become the cheapest way to get electricity.[3]

## **1.1 Aim Objectives**

During this work, a techno-economic study will be made about the analysis and modelling of a hybridized solar concentrated plant (CSP) with photovoltaic panels(PV).

The main objective of this thesis is to take advantage of each technology as explained below. Two different scenarios will be studied and then optimization of them will be done to compare the results. In the first scenario, innovations and improvements will also be incorporated in part of the plant such as the receiver, moving to a volumetric air receiver, and the use of packed bed thermal storage. In the second scenario, the use of electric batteries will be added, in order to check if, for short periods of time in which it is not usually profitable to switch on the power block, it is profitable to use energy stored in electric batteries.

Therefore, the objectives of this work are focused on adding improvements in some elements of a CSP plant hybridized with PV and trying to make it more efficient and sustainable as well as profitable and economically competitive in the current market.

## **1.2 Thesis Structure**

The first part of this work is the literature review. In this part, a compilation is made of the plants already used, and of all the information on each part of the plant in order to know how it can be improved.

The following is the explanation of the methodology used and how the modelling of each part has been done. Both the technical and economic models and their different scenarios.

Finally, all the results are shown and the conclusions reached are explained.

## 2 Literature Review

### 2.1 Solar energy

Solar resource is the most abundant clean renewable resource on earth today. 90 minutes of solar radiation are enough to supply the world's energy needs for a year.

More and more companies and institutions are betting on this type of energy because the costs are lower and the technologies are better.

Proven fossil reserves represent 46 years (oil), 58 years (natural gas), and almost 150 years (coal) at the current rate of consumption. However, capturing and storing all the energy from the sun for one year would supply the total energy consumption for 6000 years.

The total amount of energy from the sun far exceeds the amount of all other fossil resources, including uranium fission.

This is why it is so important to continue researching and improving these technologies. [4]

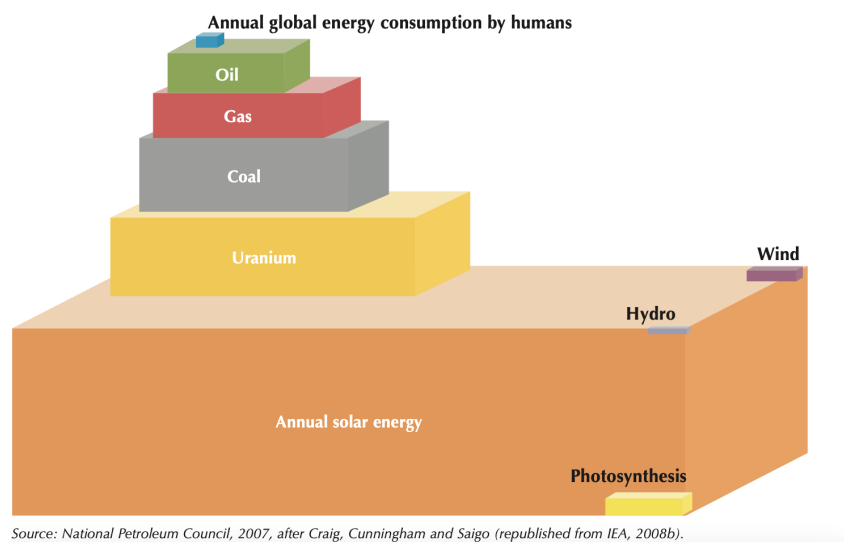

Figure 2: Total energy resources. [4]

There are two main ways of using energy from the sun: through photovoltaic panels, which generate energy directly from sunlight or concentrating solar power, which is used to run turbines to generate electricity. Also concentrated solar power, that thermal energy is obtained thanks to solar radiation.

### 2.2 Concentrated Solar Power (CSP)

Concentrated solar power plants use mirrors as solar collectors that heat a fluid to a high temperature. This fluid is fed to a turbine that spins a generator to produce electricity. In addition, this technology can be stored so that it can be used both day and night. [5]

By the end of 2019, PV technology accumulated about 578 GW of energy vs. 6 GW of CSP.[6]

The following figure 3 shows leading countries in installed concentrated solar power in 2020 (in megawatts). We can see that the country with the most installed CSP is Spain with about 2300MW followed by the United States with 1758MW.

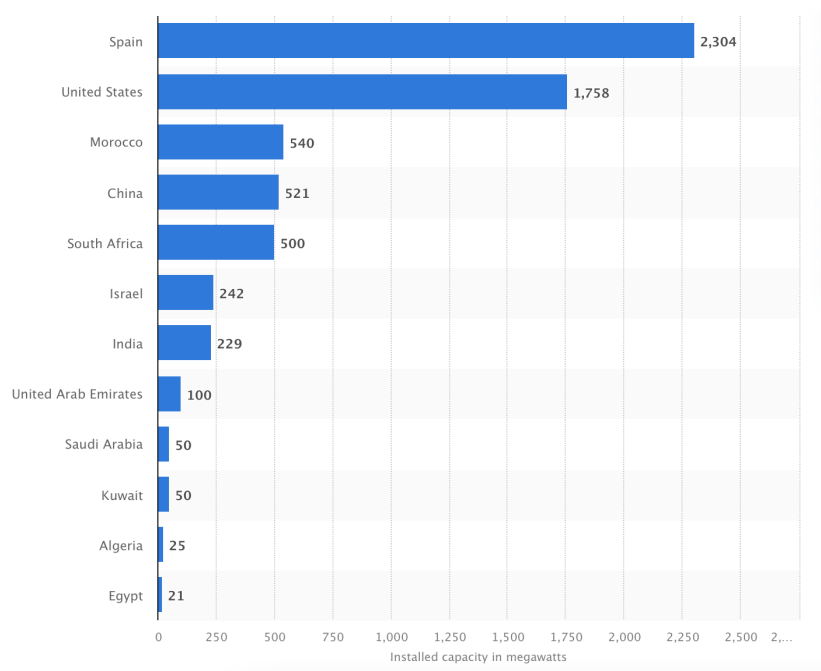

Figure 3: Leading countries in CSP in 2020 [6]

### 2.2.1 Main components of CSP system

A solar plant is mainly composed of four elements: the solar collector(heliostats and receiver) the thermal transfer fluid, the solar energy storage, and finally the power block. Each of them is explained below in figure 4

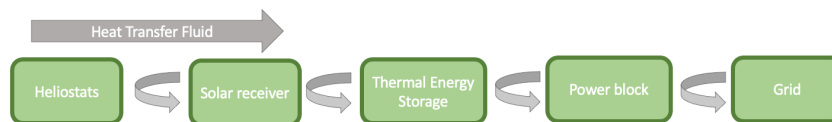

Figure 4: Main components of CSP system

#### Helioestats and receiver

The heliostats are a set of mirrors called heliostats that are able to follow the direction of the sun, where the sunlight is concentrated. In this part, two types of losses are taken into account according to two different effects. On the one hand the reflection losses that depend on the mirror material, and on the other hand the geometrical losses that depend on the direction of the sun and the geometry of the mirrors and the receiver.

Normally the mirrors should give a reflection loss of less than 10%, i.e. a specular reflectivity of 90, and high durability (a lifetime of at least 20 years). The most commonly used material is a curved thick glass with a reflective back coating of silver, and protective layers behind the silver to prevent oxidation and mechanical damage in the reflective layer. This material produces losses of less than 8%(specular reflectivity greater than 92%). It also shows great

durability, since the external glass has very robust properties to withstand different external agents.

There are four different types of CSP plants.

- **Power Tower:** The heliostats are arranged around a tower, where the receiver with the thermal liquid is located at the highest point of the tower. These heliostats concentrate the sunlight on the receiver.
- **Linear Fresnel:** Heliostats are flat mirrors that reflect the sun's rays onto a receiver, which is a tube through which the thermal fluid flows.
- **Parabolic Troughs:** In this case it is also concentrated in a tube through which the thermal fluid goes, but unlike the previous one, the mirrors are curvilinear.
- **Parabolic dish:** These heliostats are shaped like a parabolic half-revolution. Sunlight enters through an opening and is concentrated on a point located in the center of the parabola. [7] [8]

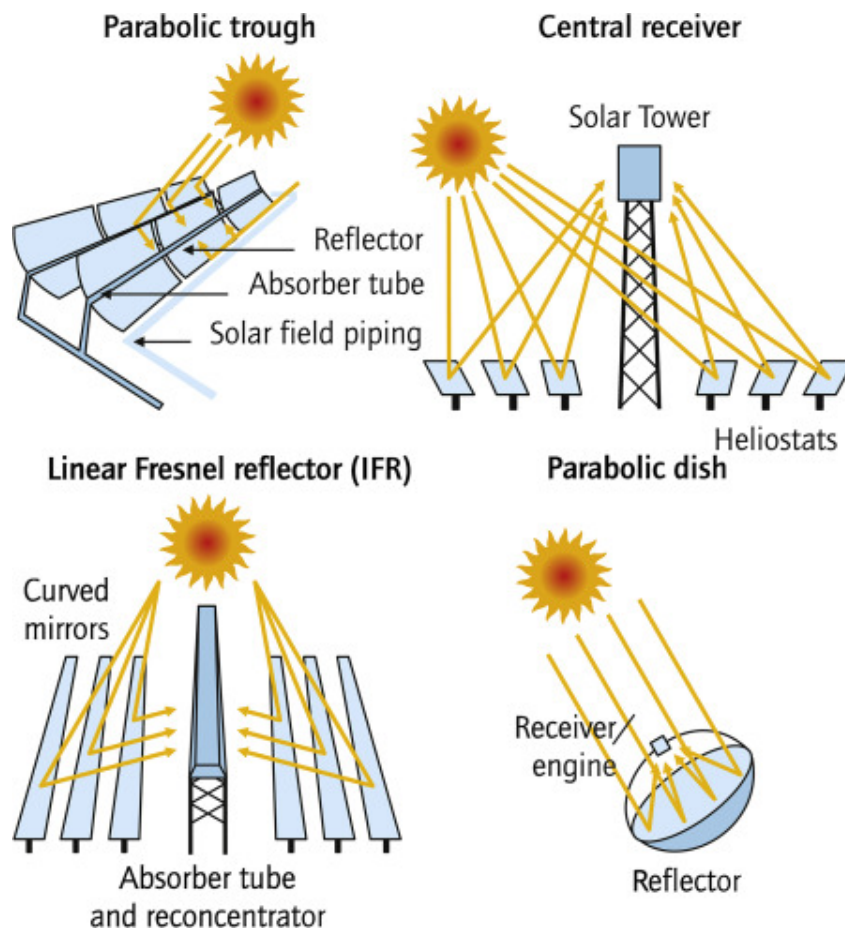

Figure 5: Types of CSP plants [7]

## Receiver

The volumetric solar receiver is typically used for point concentrations with porous materials that facilitate the absorption of solar radiation.

The operation of the receiver is to pass fluid by forced convection through the porous material, heating it to high temperatures. The outlet temperature of the material is normally between 800°C and 1200 °C. Depending on the material. The main advantage of the volumetric design compared to the tubular design is that the heat exchanger is formed by a porous structure capable of converting radiant energy into thermal energy while transmitting it to the working fluid, thus reducing convection and radiation losses. The volumetric effect is called the effect that allows radiation to spread throughout the porous material and not only concentrate on the front surface. In the following figure 6, you can understand this phenomenon.

There are different types of receivers: Open-loop volumetric receiver with metallic absorber; Open-loop volumetric receiver with metallic absorber; Open-loop volumetric receiver with ceramic absorber; Closed-loop volumetric receivers with the metallic or ceramic absorbers.

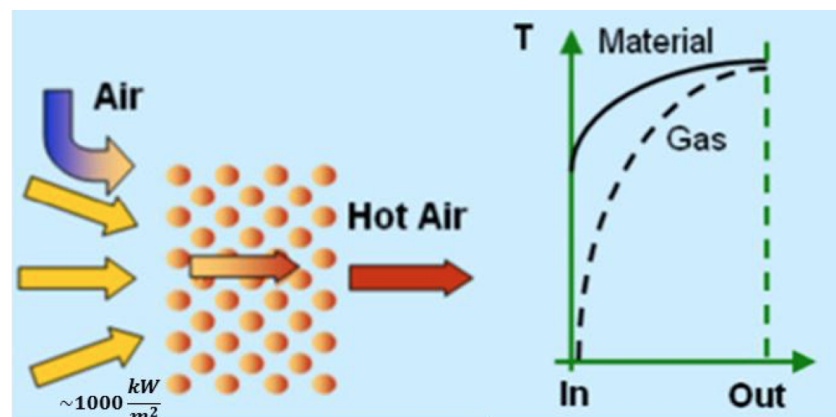

Figure 6: Volumetric effect

In this paper, we are going to discuss the Open-loop volumetric receiver with a ceramic absorber. The great advantage of working with ceramic materials is that they allow working with fluids at higher temperatures, have higher resistance to solar fluxes, and allow higher temperature gradients. Different prototypes were tested, among which the HiTrec, whose experimental results were promising, with 800°C reached as air outlet temperature and acceptable efficiencies. However, the metal structure suffered too much deformation and was subsequently improved with the HiTrec II. [9]

HiTrec-II was thought to improve the technical/economic potential of PHOEBUS-type volumetric PHOEBUS-type volumetric receivers. The receiver was composed of hexagonal modules made of SiSiC material. The most interesting part of this paper for our work is that after the tests it is obtained that the best efficiency of the PHOEBUS type receiver is 76.67% at an outlet temperature of 700°C. [10]



## Heat transfer fluid (HTF)

The HTF is responsible for capturing as much solar energy as possible from the heliostats and delivering it to the receiver. It is important that this fluid meets certain minimum characteristics, including low melting point, high boiling point, thermal stability, low vapor pressure at high temperatures, low corrosion, a high product of specific heat and density for energy storage, low viscosity, high thermal conductivity, and low cost.

In general, there are several groups of fluids used: water/steam, thermal oils, air or other gases, organic fluids, molten salts, and liquid metals.

## Thermal Energy Storage (TES)

Solar thermal storage has several purposes. The first is to decouple the generation of energy from the hours of sunshine. That is to say, when there is solar variation, to continue producing energy in a constant way. Another important objective is also to shift power generation to peak hours for a company and to make more money out of it.

A large storage capacity in plants with high solar multiples of between 3 and 4 would allow electricity to be generated 24 hours a day, for a large part of the year. This would allow low-carbon plants to compete with coal-fired power plants that emit high levels of CO<sub>2</sub>. [11]

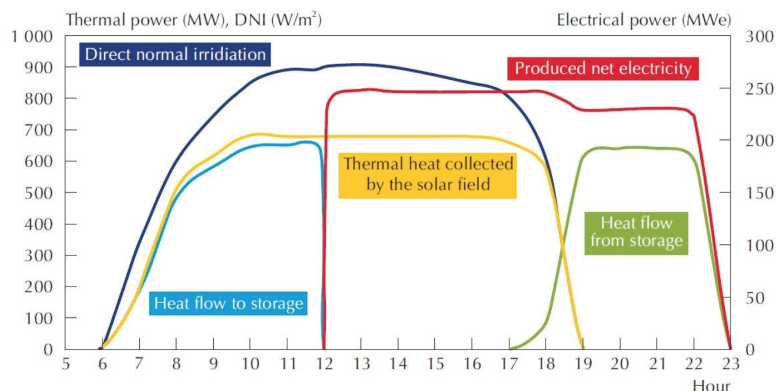

Figure 7: CSP dispatchability [11]

There are three main types of thermal storage. The first and simplest is sensible heat storage. In this type, energy is stored by heating or cooling the storage medium (either a liquid or a solid). The next is latent heat storage. In this case, the heat is stored through the process of phase change and is closely related to the latent heat of the substance. Finally, there is thermochemical heat storage which involves a chemical reaction to store the energy without loss. [1] [12]

## Packed bed thermal storage

Packed bed thermal storage has been proposed for various applications such as bulk electricity storage, advanced radiative compressed air energy storage (AA-CAES), and also in thermal process applications such as geothermal energy, concentrating solar power, and process heat. They can be used with different materials and media, but are usually locally sourced so they tend to reduce cost, as well as being non-reactive.

This type of storage is classified as sensible heat storage since it is based on the principle of thermal storage due to temperature change. Although different models have been studied in general, it is usually a cylindrical tank, filled with a solid packing medium (filler), usually alumina, ceramic or crushed rock. The transfer process takes place axially, with the fluid entering at the top and exiting at the bottom to avoid buoyancy-driven flows. The heat transfer process consists of the heat transfer fluid (usually the working fluid of the system to which the storage belongs) transferring heat to the solid. [13]

A packed bed thermal storage consists mainly of a material intended for storage with which a heat transfer is made with the heat transfer fluid.

In recent research, the use of rock as the thermal storage medium and air as the heat transfer fluid has gained importance. This has the following advantages: (1) abundant and cheap materials (2) it is possible to work with very high temperatures since the limit temperature is set by the melting temperature of the rock (3) direct transfer between both materials, (4) there are no safety problems, (5) there is no problem of degradation of chemical instability, and (6) no chemical or corrosive materials are used. [1]

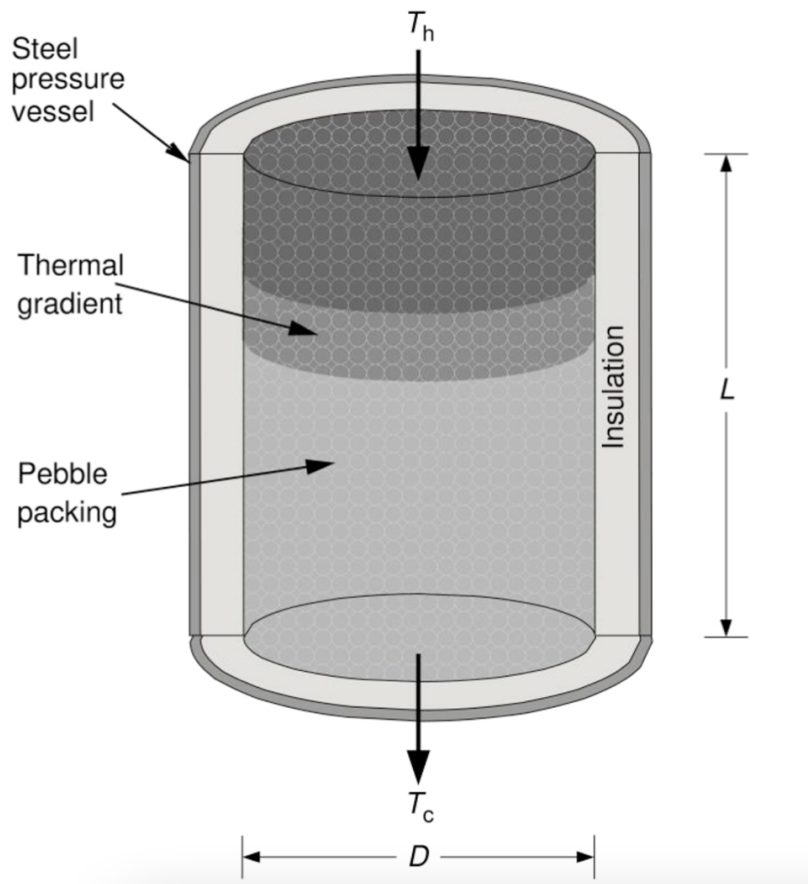

Figure 8: Schematic of a packed-bed thermal store. Hot gas enters at the top at temperature  $T_h$  and exits from the bottom at temperature  $T_c$ . [1]

### Power block

There are basically three types of electromechanical cycles to produce energy in a power plant: Brayton Cycle, Rankine Cycle, and Stirling engine systems. In this case, we are dealing with a Brayton cycle.[14]

In the work, *Performance comparison of different supercritical carbon dioxide Brayton cycles integrated with a solar power tower*, 5 different closed loop Brayton cycles are studied to see which one gives the best performance for a CSP plant. The cycles studied are the simple cycle, the regenerative cycle, the recompression cycle, the pre-compression cycle and the split expansion cycle. In all the cycles are studied with the same operating conditions and the net power and thermal energy are compared. According to the results of this work, it is shown that the recompression cycle achieves the highest thermal efficiency and the highest net power production, at peak hours, around noon alone, when solar radiation is at its maximum. [13]

The heat recovery phase is done through two heat exchangers, one high temperature (HTR) and one low temperature (LTR), and the compression phase is done in two phases, with the main compressor (MC) and the recompression with the secondary compressor (RC).

The power block operates at a low pressure of 73.8 bar, medium pressure of 161.9 bar, and high pressure of 250 bar. The inlet temperature of the turbines is set at 780 °C and that of the compressors at 32°C.

### **Solar multiple**

The solar multiple (SM) is defined as the nominal thermal power collected in the solar field divided by the thermal power of the power block.

$$SM = \frac{Q_{SF}}{Q_{PB}}$$

This ratio means, that the solar multiple is the ratio between the actual solar field size and the field needed to operate the power block at the design capacity when the solar irradiance is at its maximum for that location (typically about 1 kW/m<sup>2</sup>).

That is, an SM of 1 will result in only operating at rated power when solar irradiance is at its maximum. However, an SM greater than 1 allows the plant to maintain full production even if the solar input is less than 100%. For small storage plants, the optimum SM is usually between 1.1 and 1.5, while for large storage plants it is usually between 3 and 5. [11]

## **2.3 Photovoltaic**

Photovoltaic (PV) technology is named after the photovoltaic effect. This phenomenon consists of the conversion of light (photons) into electricity (voltage). [15]

Photovoltaic panels, also known as solar cells, are electronic devices that directly convert solar energy into electricity. They are used for small-scale and large-scale applications (residential and commercial buildings). In recent years their price has decreased so much that they have become the cheapest way to get electricity.

### **2.3.1 Concepts and definitions**

The performance of photovoltaic panels is usually defined by three parameters, voltage, power, and current, which are interrelated in two curves. As shown in the next figure:

[16]

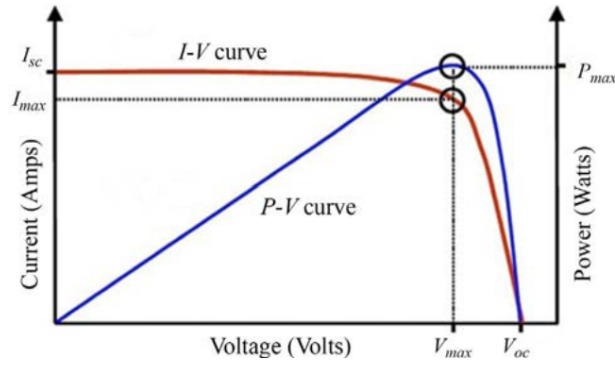

Figure 9: Performance PV panels [16]

Photovoltaic performance is very directly related to incident light. Solar incidence can vary across different parts of the world. As we can see in image 10, where the GHI shows the global horizontal irradiance and is related to the DHI diffuse solar irradiance and the DNI the direct normal irradiance, which is the parameter used in the modeling of this work. [16]

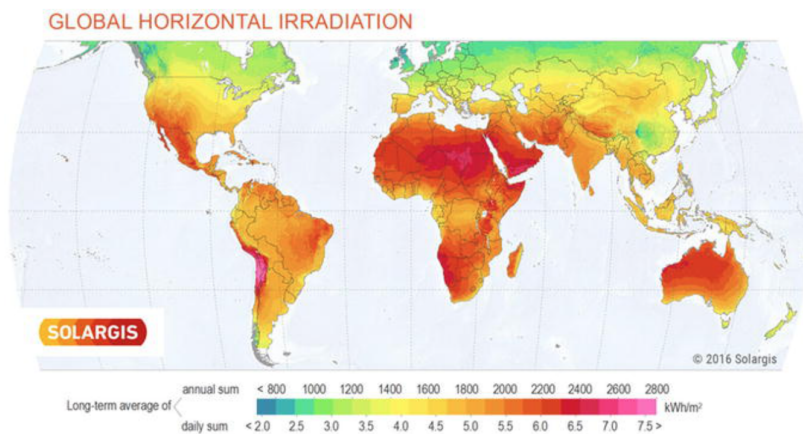

Figure 10: Horizontal Global Irradiance [16]

The DNI is related to the GHI and DHI through the equation:

$$GHI = DHI + DNI \times \cos\theta$$

Where  $\theta$  is the solar zenith angle.

### 2.3.2 Electric batteries for PV

A typical utility-scale battery storage system has a capacity ranging from a few megawatts (MWh) to hundreds of MWh. Lithium-ion batteries (Li-ion), sodium sulfur batteries, and lead acid batteries can all be used for grid storage. [17]

A comparative overview of large-scale battery systems for electricity storage for electricity storage and a comparative study of different types of electric batteries are made. In conclusion, it is concluded that both lithium-ion and sodium-sulfur batteries have higher energy and

power densities as well as higher efficiencies. [18]

## 2.4 Hybrid

The CSP-PV hybrid system consists of taking advantage of both technologies to generate energy at a low cost and in a constant and efficient way.

On the one hand, PV has the advantage of being the most mature and cheapest technology, but its storage in electric batteries is very expensive. Therefore, it is a technology that is normally consumed at the time of generation.

On the other hand, CSP is a more expensive technology but it is easier to store and cheaper in thermal storage, thus allowing the use of energy at times when there is no sun.

A hybrid plant for these two technologies consists of using the PV energy during sunshine hours and storing the energy generated by the CSP to be used when the sun is not shining. [19] [20]

In this article, one of the main problems of hybridization between CSP and PV plants is discussed: discontinuity and intermittency of electricity production. For this purpose, a CSP plant is designed for storage for long periods and with PV for electric batteries for short periods of storage. In addition, it is studied in two locations to see how it can be affected. The results show that these two technologies can work well regardless of the location of the plant. This system is not as interesting for short periods of electrical demand where only the PV panels work, and also because there are more energy losses due to having two storage.

This article presents a mathematical model to calculate the LCOE of both CSP and PV technology, presenting as final results the evolution of the LCOE from 2010 to 2050, as well as the most influential factors on which a sensitivity analysis should be performed. The five main conclusions reached in this article are: 1. The LCOE will be reduced substantially in the first 20 years, i.e. from 2010 to 2030, thereafter it will have a much slower reduction. However, PV at first will not have such a rapid reduction but could eventually reduce its cost much faster. 2. The LCOE of PV varies a lot depending on the initial costs, however, the LCOE of CSP does not vary so much with its initial costs which depend a lot on thermal storage. 3. The future evolution of the LCOE depends strongly on the learning rates and the predicted values of the cumulative installed capacity function are also strongly influenced by the specific curved time paths followed by this function. 4. Two of the most influential parameters are the discount rate and the local resource. 5. Between these two technologies it is also concluded that PV technology would be more advisable for mid-high latitudes and partly cloudy climates. And CSP technology for arid and semi-arid climates [21] [22]

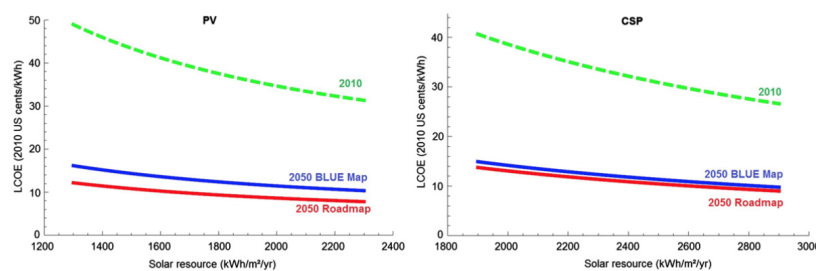

Figure 11: Evolution LCOE CSP and PV from 2010 to 2050 [23] [22]

In Summary, this literature review has shown the existence of CSP plants with thermal storage, normally storage made up of two tanks, one cold and the other hot. The existence of PV plants with electric batteries. It has also been seen how there are CSP plants with compact bed thermal storage and air receivers. But what has not yet been studied and is reflected in this work, is a CSP plant with a volumetric air receiver with compact bed thermal storage hybridized with PV. Subsequently, electric batteries will be added to this same plant, in order to study whether it would be an economically competitive plant in the current market.

### 3 Methodology and modelling of the plant

#### 3.1 Methodology

In this work a techno-economic model is being developed, so the modeling basis of this work is, on the one hand, a technical model, on the other hand, an economic model, and finally, a model that integrates both in order to obtain the results.

First, the technical model is developed. First of all, the plant design parameters and assumptions are established. Once this is done, each main element of the plant is modeled and then all of them are integrated into one.

With the financial model all the cost parameters, all the costs and the KPI's to be obtained are established.

Combining both, the techno-economic model is obtained. Once it has been obtained, the KPI's can be evaluated, and then move on to optimization. For optimization, the variables that can be changed to improve the performance of the plant are evaluated and these will be the design parameters. With this, we go back to the starting point until an optimal solution is obtained.

In the case of this work, we will be in front of an optimal solution when we have a competitive and improved solution with the current market.

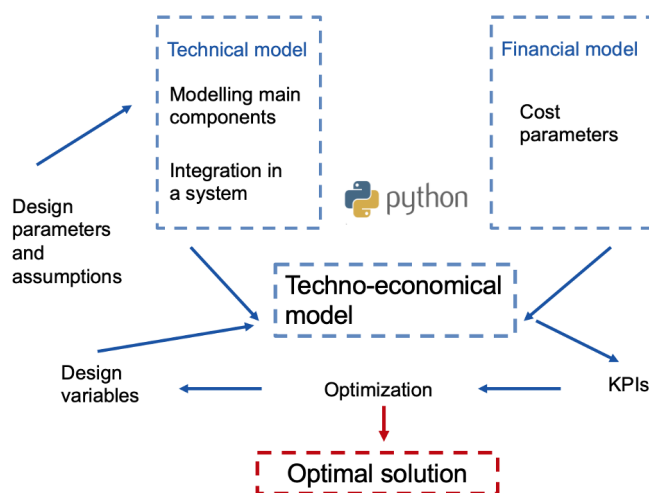

Figure 12: Methodology

### 3.2 Description of the model

In this work, as already explained, two cases are studied, first a base case in which the CSP part is treated with the PV part. Figure 13 shows the layout.

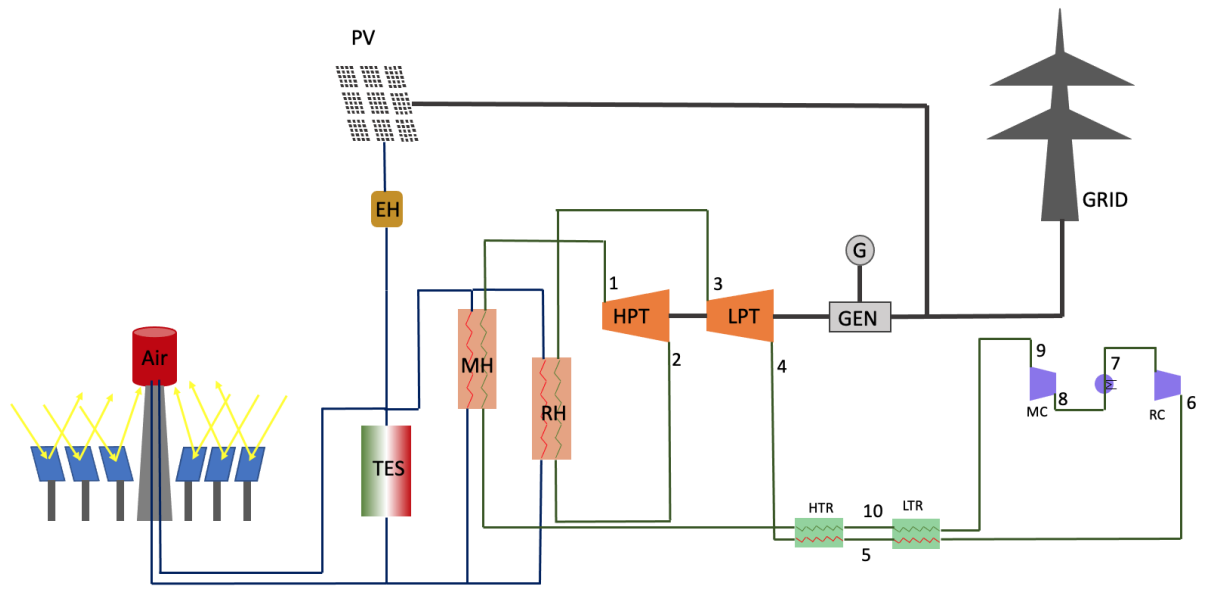

Figure 13: Layout system base case

On the left side of the picture is the CSP part with all the components. This is the part of the parabolic dish heliostats, which will capture the sun's rays and redirect them to the receiver which is located in the centre of the heliostat field. This central, volumetric tower receiver uses air as a thermal fluid. This is where the energy exchange with the thermal fluid takes place. This fluid is directed to the thermal storage (TES). In this element, the heat is transferred to the solid, in this case rocks, to store the energy and use it later when there is no sun to produce electricity.

At the top, you can see the photovoltaic plant. During sunshine hours, electricity is produced and fed directly into the grid. In this case, the grid has a fixed consumption of 100 MWe. At the moment when this 100 MWe is being produced, and more energy is being produced by the photovoltaic panels, this energy needs to be stored in order not to be lost. As the photovoltaic panels produce electricity directly, which cannot be stored in the TES, it must first be converted into thermal energy. For this purpose, the electric heater, referred to in the picture as EH, is used. This is where all the excess energy is directed through the solar panels and converted into thermal energy. Once this energy has been converted, it is directed to the TES for storage.

Finally, the last part of the layout consists of the power block. Once there is no sun to use this energy, the power block is turned on, which, using the thermal energy stored in the TES, manages to generate the necessary electrical energy needed to inject into the grid.

After modelling this layout, the same layout is used by adding electric batteries as shown in figure 14.



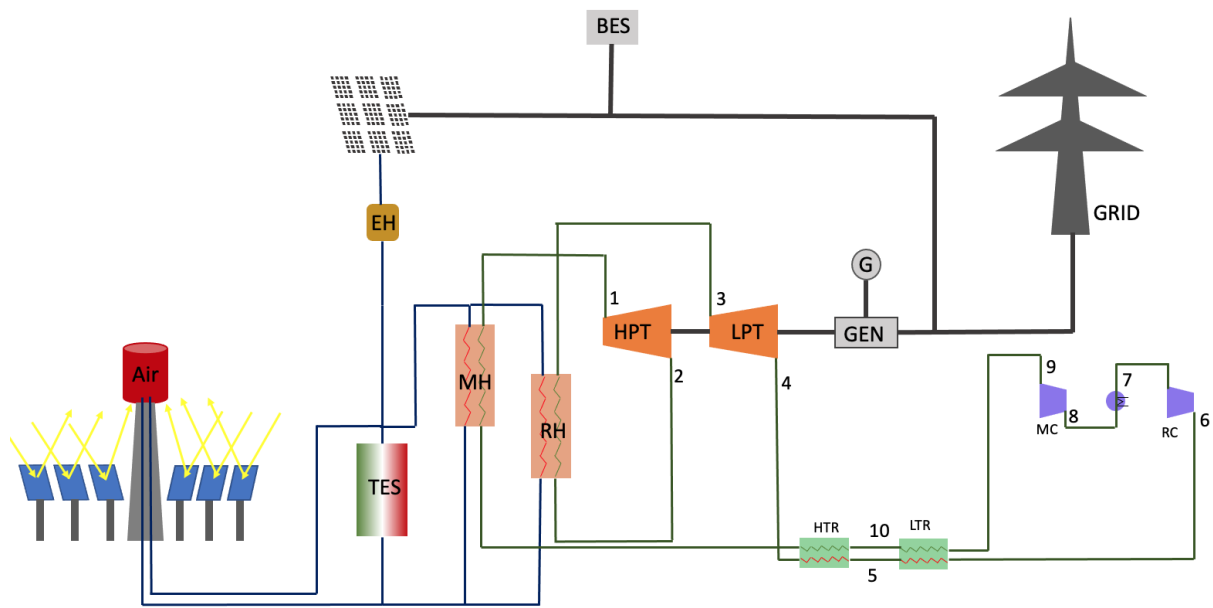

Figure 14: Layout system with electric batteries

This system is the same as the previous one but with the addition of electric batteries. So, when there is over a generation in the photovoltaic panels, before passing this electricity to the electric heater, it will be used to charge the electric batteries. In this way, when there is no sun, either at specific times or before turning on the power block, this energy can be used and thus see if it is feasible or not.

### 3.3 Control strategy

As can be seen in figure 15 , the control strategy followed in this work on a typical day is explained below.

On a typical day, normally from midnight to more or less four o'clock in the morning there are no sun hours, so the electricity generated by the power block will be used. Once the sun starts to rise, more or less from four in the morning to seven in the afternoon, it will start generating energy with solar panels and thermal storage. All the energy needed to inject it into the grid, in this case, 100 MW, is obtained with the solar panels. All the energy generated by the CSP is stored in thermal storage for later use. As soon as we start generating more than 100 MW with the photovoltaic panels, i.e., we have surplus energy, it is transformed from electricity to thermal energy with the electric heater and is also stored in the thermal storage.

Once there are no more hours of sunshine, the electricity from the power block is used again, which uses the thermal energy stored in the storage during the hours of sunshine.



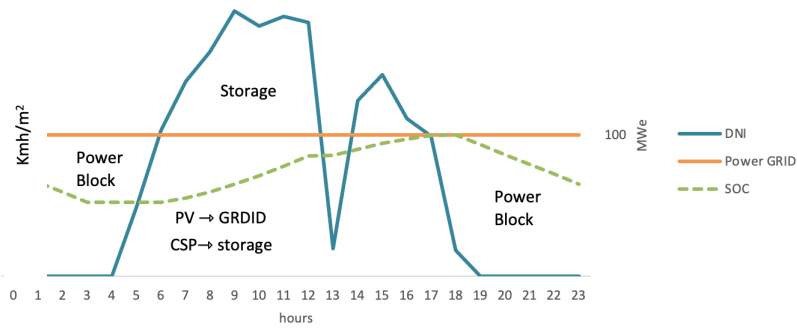

Figure 15: Control strategy

### 3.4 Modelling the main parts

First of all, a first case has been modeled, which is called the base case, where the main elements to be modeled in this work are the receiver and the thermal storage.

Subsequently, the operation of the electric batteries has been modeled and added to the previous model.

Finally, the optimization of the system has been carried out.

#### 3.4.1 Receiver

As explained in the literature review, one of the advantages of using this type of receiver is the high temperature at good efficiency.

Two types of efficiency have been modeled with this receiver. On the one hand, there is the fixed efficiency, which has an output temperature of 800 and achieves an efficiency of 76%. On the other hand, there is a variable efficiency that depends on the parameters  $c$  and the outlet temperature as shown below in the figure 16. This variable efficiency has been chosen in this work.

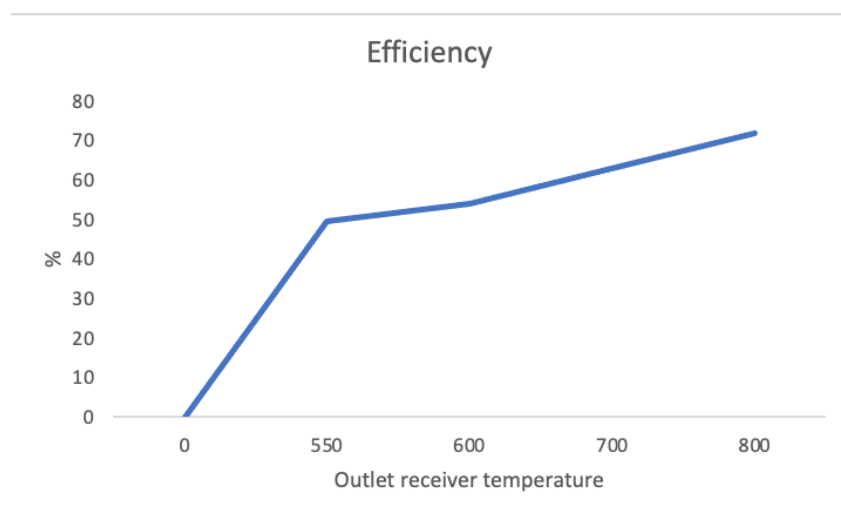

Figure 16: Receiver efficiency

The shape of the receiver has also been modeled as hexagonal modules.

### 3.4.2 Packed bed TES

To model the packed bed TES, the following curves have been used as a good simplification and approximation of the TES outlet temperature and its relation to the State of Charge (SOC) that has been done in this work, *Packed bed thermal energy storage: A novel design methodology including quasi-dynamic boundary conditions and techno-economic optimization*.

Figure 17 below shows how the TES outlet temperature evolves with respect to time depending on whether it is in charge or discharge mode. This curve has been evaluated via the solution of PDE set (fluid and solid equations) for a similar packed bed

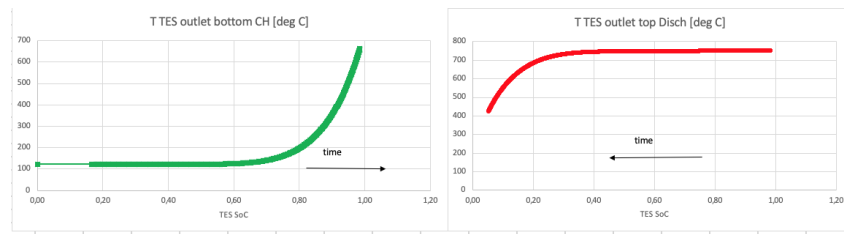

Figure 17: Outlet temperature TES

The following equations were derived from these curves and used in the model.

$$T_{out,ADIM} = p_1 \cdot SOC^5 + p_2 \cdot SOC^4 + p_3 \cdot SOC^3 + p_4 \cdot SOC^2 + p_5 \cdot SOC + p_6$$

$$T_{out}[K] = T_{out,ADIM} \cdot (T_{outREC} - T_{aDES}) + T_{aDES}$$

Where  $p_1, p_2, p_3, p_4, p_5$  and  $p_6$  are coefficients as shown below.

Polynomial Fitting	p1	p2	p3	p4	p5	p6
Coeff Charge	13,492	-25,692	18,106	-5,581	0,6678	-0,0149
Coeff Discharge	9,398	-30,1725	37,732	-23,002	6,872	0,1829

Figure 18: TES coefficients

The thermal storage has been designed according to the following equation:

$$V_{TES} = (E_{TESmax}) / (C_p \cdot (T_{MAX_{TES}} - T_{MIN_{TES}}) \cdot N_{tes} \cdot \eta)$$

Where:

Etesmax: maximum thermal energy that can be stored

Cp: heat capacity of thermal storage

Tmaxtes Maximum temperature of thermal storage

Tmintes: Minimum temperature of thermal storage

Ntes: TES units

$\eta$ : yield

Another important parameter in the design of the TES is the cut-off temperature. This means that there is a temperature  $T_{cut}$ , below which the required outlet temperature is no longer achieved, and therefore the tank stops discharging. Taking this into account, and the fact that a zero SOC will never be reached, the oversized tank has been designed by 20 %.

### 3.4.3 PV

The YGE 72 CELL SERIES 2 - P = 325 W model has been used for the design of the PV plant. With the power per PV cell and the time and location data we can obtain how many modules are needed, for how many hours per day we will reach more than 100 MW of production and therefore we will have to bring to the electric heater.

The main data required for the photovoltaic plant are as follows:

<b>Parameter</b>	<b>Values</b>
Maximum Electric Power that can be injected to the grid	100MW
AC nameplate system capacity (inverter)	50MW
DC-to-AC ratio	1.2
Ground coverage ratio	0.4
Inverter efficiency at rated power	98%
Single PV module DC power output	325 W
Single PV module area	1,97m <sup>2</sup>

Figure 19: PV inputs

## 3.5 Main inputs

Below are the main values that have been set at the beginning of the model and are the ones that affect the model the most. These are the solar multiplot, which defines the size of the solar field; the power of the photovoltaic panels, which together with the fixed electricity needed by the grid is used to obtain the nominal power of the heater. This is the subtraction of the maximum electrical power of the photovoltaic panels minus the electrical power of the grid, provided that the electrical power of the PV panels is greater than that of the grid. Otherwise, all the energy generated by the PV would go to the grid and the electric heater would not be needed. It is also defined as an important input for the hours of thermal storage as this will define the size of the TES, and finally the power of the electric batteries and their hours of storage.

Parameter	Values
Power maximum injected to the GRID	100MW
SM	2,5
AC nameplate system capacity	200 MW
Hours of thermal storage	12
BESS power	25MW
Hours BESS	3

Figure 20: Main inputs

Finally, some temperatures have also been set as inputs, such as the receiver outlet temperature and the turbine inlet temperature, which will be a little lower due to losses. The receiver outlet temperature and the turbine inlet temperature, which will be a little lower taking into account the losses, have also been defined, as well as the inlet temperature to the PB compressor, and the ambient design temperature, and the pressures at which the PB works.

Parameter	Values
Temperature Outlet Receiver	800 °C
Temperature inlet turbine	780°C
Temperature inlet compressor	32°C
Ambient temperature at design point	28 °C
High pressure PB	250 bar
Intermediate pressure PB	161,9 bar
Low pressure PB	73,8 bar

### 3.6 Key Performance Indicators (KPIs)

The KPIs used in this work are as follows:

**LCOE:** The main indicator, which is used to compare with other plants, is the LCOE (Levelized Cost of Energy). This indicator takes into account all capital and operating costs over the lifetime of the plant. What it does is to add up all the costs and divide them by the plant's energy capacity factor. It is a way to standardize a parameter to be able to compare plants from different energy sources.

$$LCOE = \frac{C_{fix} + \sum_{i=y}^y C_y \cdot CRF_y}{\sum_{i=y}^y G_y \cdot CRF_y}$$

$$CRF_y = (1 + r)^{-y}$$

Where each parameter means:

- Cfix: Capital investment costs incurred for setting up the project
- Cy: Operational costs incurred in year y
- CRFy: Capital recovery factor in year y
- Gy: Generation of electricity in year y
- y: years of plant life
- r: required rate of the return period

**CAPEX** : is the parameter that includes the capital expenditures of a facility. Includes both direct and indirect capital.

To calculate the CAPEX it is necessary to first calculate the following parameters.

Direct capital cost subtotal with subsidies:

$$C\_Cap\_dir\_sub=(1-f_{subs}) \cdot C_{cap}$$

Direct capital cost total:

$$C\_Cap\_dir\_tot=(1-f_{contingency}) \cdot C\_Cap\_dir\_sub$$

Indirect capital cost total:

$$C\_Cap\_indirect=(f_{EPC} + f_{decommissioning}) \cdot C\_cap\_dir\_tot + C\_land$$

$$CAPEX= C\_cap\_dir\_tot + C\_cap\_indirect$$

**OPEX**:Finally, we have OPEX as an important parameter. This includes all operating and maintenance costs, i.e., all costs incurred each year. Unlike CAPEX, which is the cost of the initial investment. It is calculated as follows:

$$OPEX = C_{year} + OM_{production} \cdot EPY$$

**CF**: Capacity factor: It is the ratio between the actual energy generated and the energy generated if the plant would have operated at full load for the same time.

**AEY**: It is the KPI of the total energy produced during the whole year in the plant.

### 3.7 Economic Model

The main economic data used in the economic model as well as the equations are shown below.

The below table shows the costs that have been used to calculate the cost of the TES. The packed bed TES consists of different types of insulation, one high temperature and one low temperature, and a layer of steel. The foundation refers to the part that has to be laid with the floor.

In the figure below 2: The costs of the components of the PB used in the economic model are shown, which are the main ones, as the costs of the smaller ones such as pipes or valves have been disregarded.

Table 3 shows the economic values of the other parts of the CSP plant, including the costs of the solar field and the receiver.

Specific cost, $c_i$	Value	Unit	[noauthor'constrained'nodate]
High temperature Insulation	4269	[\$/m <sup>3</sup> ]	[noauthor'constrained'nodate]
Low temperature Insulation	616	[\$/m <sup>3</sup> ]	[noauthor'constrained'nodate]
253 MA Stainless Steel	42,354	[\$/m <sup>3</sup> ]	[noauthor'constrained'nodate]
Natural Rocks	66	[\$/m <sup>3</sup> ]	[noauthor'constrained'nodate]
Foundations	1210	[\$/m <sup>3</sup> ]	[noauthor'constrained'nodate]

Table 1: Specific costs for TES materials

Unit	Reference Cost, $C_{ref}$ [\$]	Exponent, $exp$ [-]	Reference
Turbine, HPT [weiland'sco2'2019]	LPT	406'200	0.8
Compressor, MC [weiland'sco2'2019]	RC	1'230'000	0,3992
Primary Heater, MH [ho'cost'2015]	RH	17,5	0,8778
Recuperator, HTR [weiland'sco2'2019]	LTR	49,45	0.7544
Cooler	32.88	0,75	[weiland'sco2'2019]

Table 2: Reference costs and exponent for main components in the sCO2 power cycle

Parameter	Symbol	Value	Unit	[coventry'heliostat'2016]
Heliostat specific cost	$C_{helio}$	120	[\$/m <sup>2</sup> ]	[trevisan'thermo-economic'2020]
Heliostat surface	$A_{helio}$	148.84	[m <sup>2</sup> ]	-
Land Cost	$C_{land}$	8.9	[\$/m <sup>2</sup> ]	[trevisan'thermo-economic'2020]
Tower specific cost	$C_{tower}$	1'600'000	[\$/m <sup>2</sup> ]	[trevisan'thermo-economic'2020]
Tower reference height	$H_{TOWER,Ref}$	75	[m]	-
Receiver reference cost 1	$C_{Rec,1}$	79	[\$/°C]	[trevisan'thermo-economic'2020]
Receiver reference cost 2	$C_{Rec,2}$	42'000	[\$/°C]	[trevisan'thermo-economic'2020]
Compressor reference costs	$C_{AirC,1}$	27,7	[\$]	[trevisan'thermo-economic'2020]

Table 3: Reference costs for main components in the solar field

### 3.8 Base Case: Ourzazate

Ouarzazate is a city in southern Morocco and is part of the Draa-Taifilalet region. It is a city that is close to the Atlas Mountains and the valley of the Draa River. The climate in Ourzazate is characterized by hot, arid, and clear summers and cold and clear dry winters.



Figure 21: Ourzazate location

In figure 22 can be seen the DNI profile per month in Ouarzazate. This gives an idea of how is going to vary the energy production from the sun each month

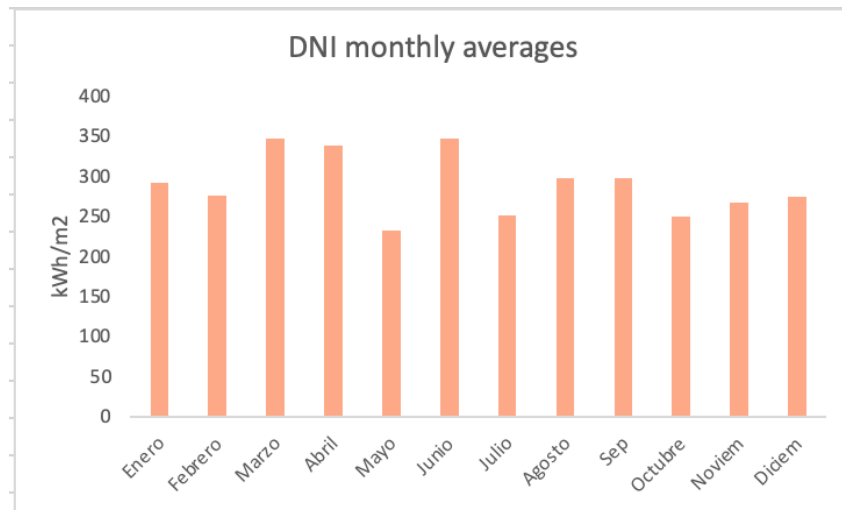

Figure 22: DNI per month

Until a few years ago, 97% of Morocco's energy came from fossil sources, however, with the country's conditions and the construction of solar farms, it is possible to compensate for this use of fossil energy with renewable energy. In addition, in 2018, the country decided to change its time use to GMT +1, a fact that made the country reduce energy consumption in addition to having more daylight hours useful for power generation.

As for the poverty part, solar farms are also of great importance. In recent years poverty in Morocco has been reduced, and there has always been a class difference between urban and rural areas. Improving the efficiency of solar plants makes it cheaper to get energy and easier

to access in rural areas. In addition, it creates jobs which also fights poverty.

Having more solar energy and even having a surplus to import helps Morocco to be less energy dependent, improve relations with other countries and boost the Moroccan economy.

Morocco has been a country that has fought a lot against climate change and this is a crucial step to it. It has many policies that fight climate change, for example, they are implementing the Green Generation plan that encourages farmers to conserve water and energy and to grow crops more efficiently.

The improvement of solar plants in Morocco has a great positive impact, not only in the fight against climate change but also in the economic, political, and social spheres, helping to fight poverty and promoting equality between classes.



## 4 Results

Different scenarios have been modeled in this work. The first one is the base model, the hybrid plant with CSP and photovoltaic panels. In the second scenario, electric batteries have been added. Finally, the optimization has been done, modifying some variables and optimizing the LCOE function.

### 4.1 Base model

In the following, the results of the plant working without battery power according to the strategic control described above will be visualized.

In figure 23, it can see the performance during a week in summer and in the below figure it can see the performance during a week in winter.

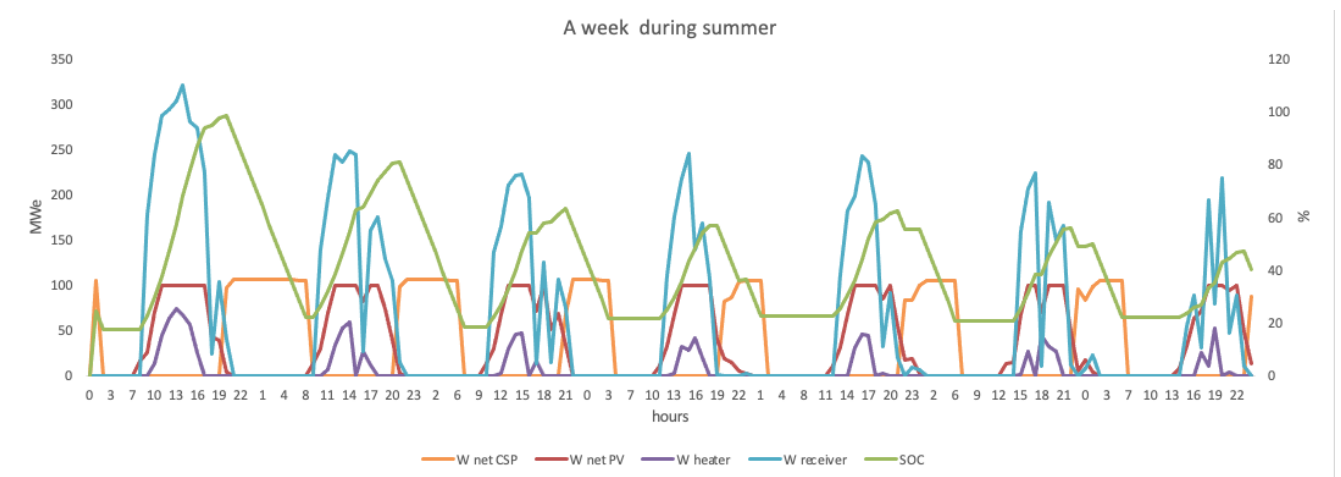

Figure 23: Plant performance during a week in summer

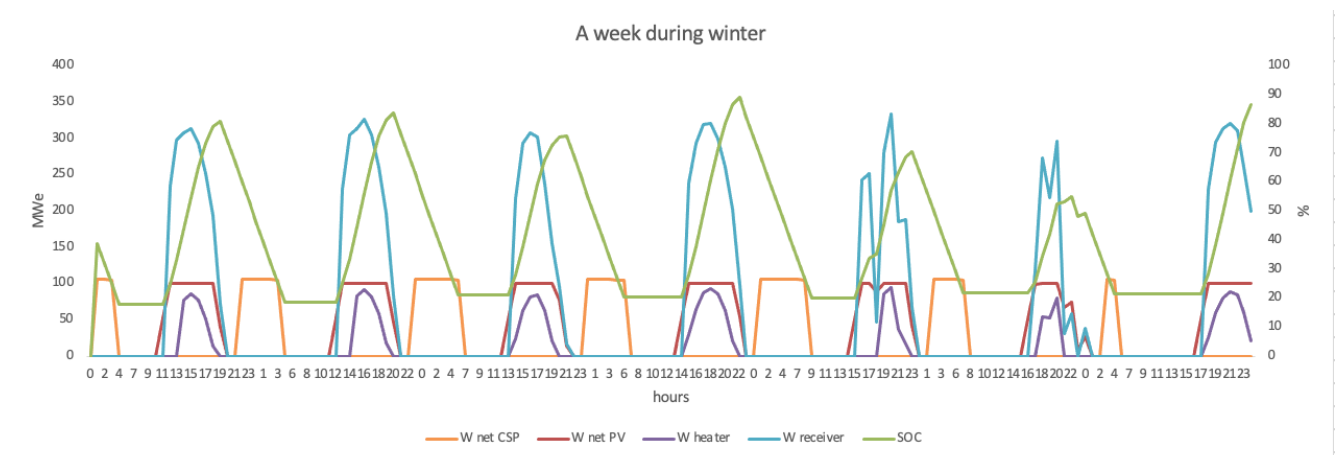

Figure 24: Plant performance during a week in winter

During the hours of sunshine, less power is needed from the power block and it starts to be generated by the photovoltaic panels. In the hours of the day with more solar radiation

(usually around midday) is when the solar panels exceed the 100 MW (demanded by the grid) generate the surplus energy that is sent to the electric heater to transform the power into energy and thus store it.

The receiver energy profile has the same shape as the PV power output, as it simply describes the higher the DNI, the more energy the receiver will be able to harvest and store. The profile of the electric heater energy curve coincides with the hours when more than 100 MW is being generated by the PV and therefore this surplus energy is stored. The difference between summer and winter is that although the same power is generated by the receiver, it is generated for more hours in summer and less in winter. Something similar happens with the electric heater, as you can see, during the summer there are more hours of surplus photovoltaic energy and therefore more hours where there is energy in the electric heater.

When the receiver is not working because either we cannot store more energy or there is no sun, the workflow is zero and there is no heat obtained, therefore the output temperature is the same. In this case, 800°C, as it is an input fixed in the model to get the maximum performance from the plant.

In the SOC graph, it can be seen that the SOC is higher in the summer, as more energy is being obtained in the receiver and in the electric heater, and more energy can be stored in the TES during the summer.

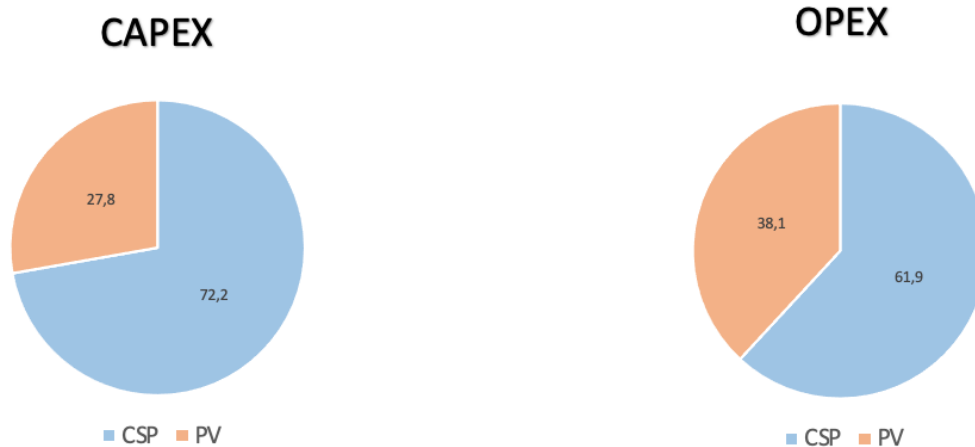

Figure 25: CAPEX and OPEX costs

<b>LCOE</b>	89,41 \$/MWh
<b>CAPEX</b>	583,7 M\$
<b>OPEX</b>	6,9 M\$/year
<b>AEY</b>	473,24 GWh
<b>CF</b>	51,18 %

Table 4: KPIs base case

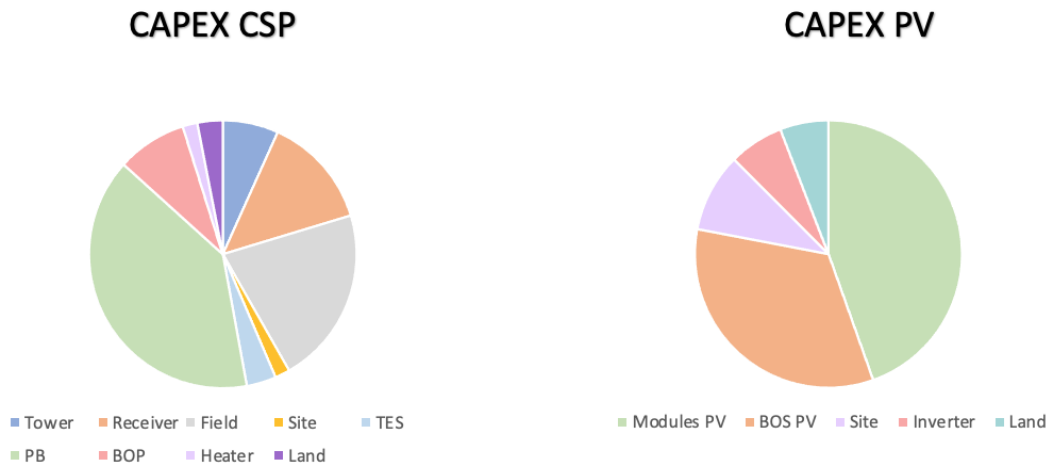

Figure 26: CAPEX costs

The base case LCOE is 89,41 \$/MWh. This parameter takes into account both capex, opex and total plant output. As can be seen from the total capex and total opex, most of the costs are related to CSP, as can be seen from the fact that CSP is a much more expensive technology than PV.

This plant in this scenario works with a capacity factor of 51.18%. This means that it generates almost half as much electricity as it would have generated if it had been running at full load at all times.

In the CAPEX, the highest percentage is from CSP, as it was expected to have a higher capital cost, as well as the same for the annual costs (OPEX).

## 4.2 Plant with BESS

Below are the figures of the results after the addition of the batteries to the previous model.

In the following pictures, you can see the performance of the model with both summer and winter batteries.

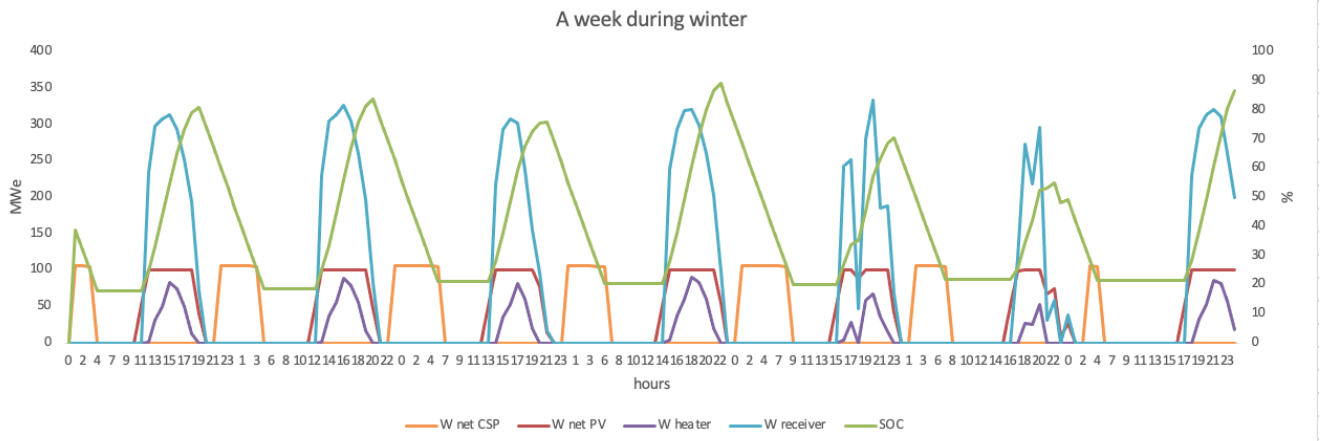

Figure 27: Performance of the plant during a week in winter

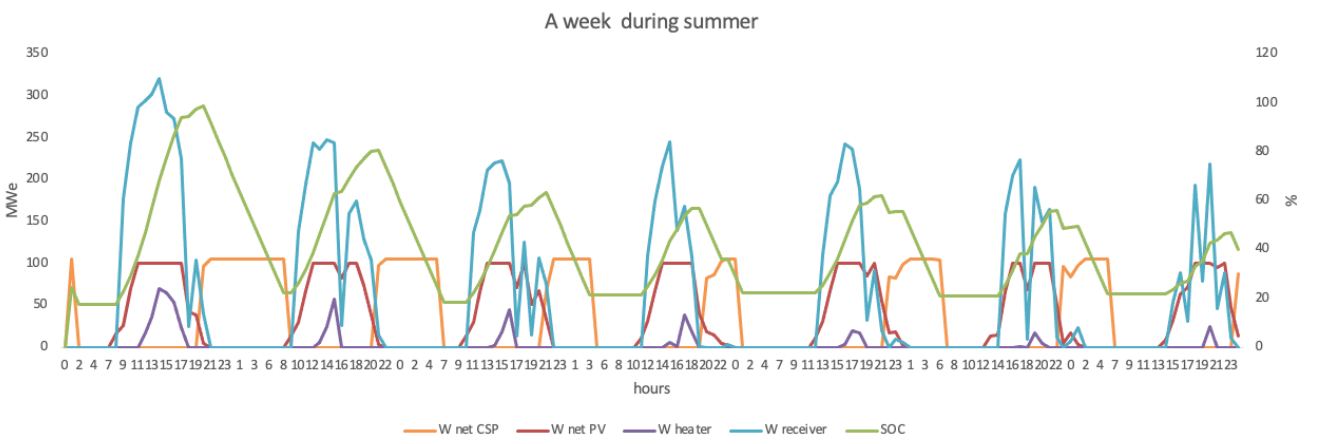

Figure 28: Performance of the plant during a week in summer

It can be seen that the moment when the photovoltaic panels start to run out of electricity before they start to use the energy from the CSP, the energy stored in the batteries is used.

The difference between the EH and the first scenario is that the energy that is sent to the electric heater has only decreased during the first three hours that some of the surplus energy from the PV is stored. Three hours because that is the maximum capacity of the batteries as the batteries are designed in this scenario.



Figure 29

In this scenario, the batteries are designed to charge a maximum of 25 MW for three hours. Therefore it can be seen how during the first three hours that there is surplus energy the batteries are charged and during the first three hours that the photovoltaic energy does not reach 100MW this energy is used from the batteries before starting up the CSP plant.



Figure 30

<b>LCOE</b>	93,29 \$/MWh
<b>CAPEX</b>	634,5 M\$
<b>OPEX</b>	6,9M\$/year
<b>AEY</b>	486,27 GWh
<b>CF</b>	52,6 %

Table 5: KPIs BESS

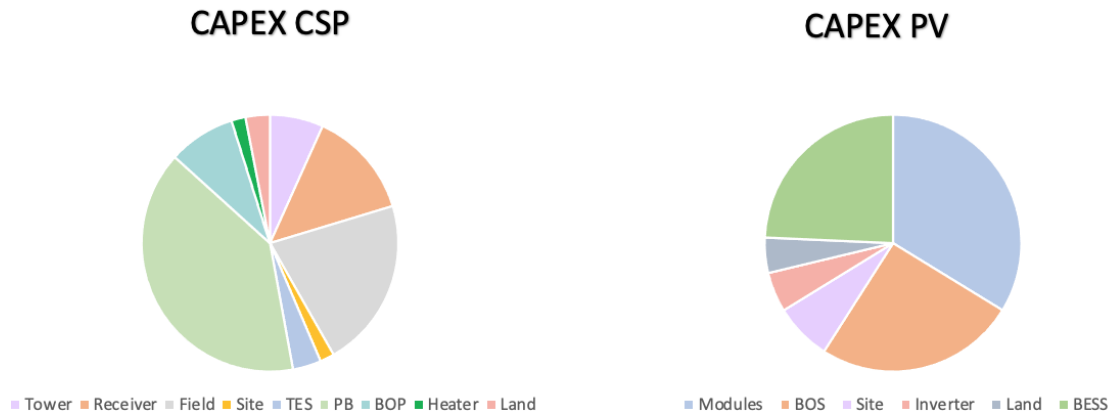

Figure 31

Looking at the KPIs and the graphs of CAPEX and OPEX, it can be seen that the LOCE has risen because despite also increasing the energy produced by the plant, the addition of the batteries means an increase in CAPEX, with the batteries accounting for 10% of this parameter.

### 4.3 Optimization

The optimization used is following the genetic algorithm, one of the most widely used heuristics for optimization and search problems.

The optimization has been done by choosing as design variables those variables which, by changing them, could improve the performance of the plant as much as possible. As an objective equation, the LCOE equation has been used with the aim of minimizing the aim of achieving economic savings. This was the KPI used for the optimization as it is the KPI that best represents the costs of the plant taking into account also the production.

The parameters selected as design variables have been: the photovoltaic energy produced, the hours of thermal storage (this determines the size of the storage), the maximum power of the electric heater, the power of the electric batteries, and the hours of energy storage in the electric batteries.

Below is a graph showing the range of values given to the design variables in the optimization. [24]

Parameter	Lower bound	Upper bound	Units
SM	0	4	-
hours TES	6	18	hours
Power BESS	0	30	MW
hours BESS	0	5	hours

Table 6: Boundaries optimization

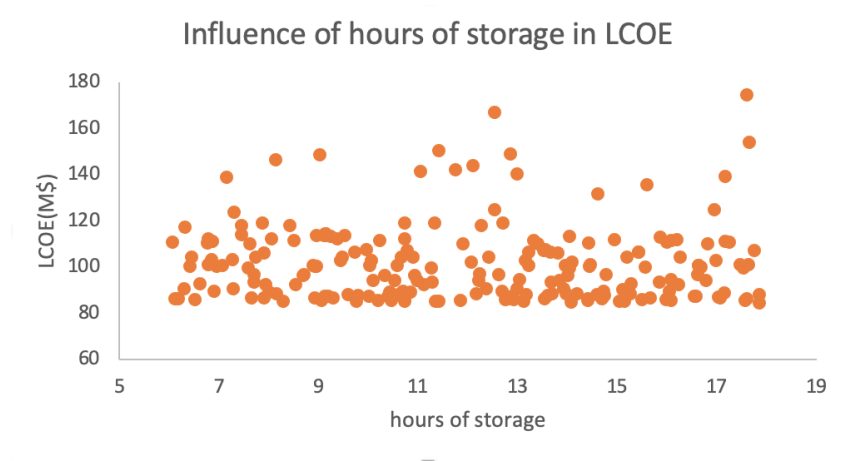

Figure 32: Influence of the hours of the TES in the LCOE

To see how the storage hours influence the LCOE, it is necessary to know how the storage hours influence the design of the TES. First of all, the hours of storage influence the maximum energy that the TES can store, which is one of the parameters used to use the TES. Therefore, on the one hand, this will increase the CAPEX, as the larger the TES size the higher the capital cost. But, in the graph of figure 32 you can see how this does not only follow. This is because, for the calculation of the LCOE, not only the costs but also the energy production is taken into account. During the optimization, different sizes of TES have been tested, in order to find the one that best fits has the storage capacity for the hours that energy needs to be used for the PB because there is no sun, but without going overboard in order not to pay extra capital costs without it being necessary.

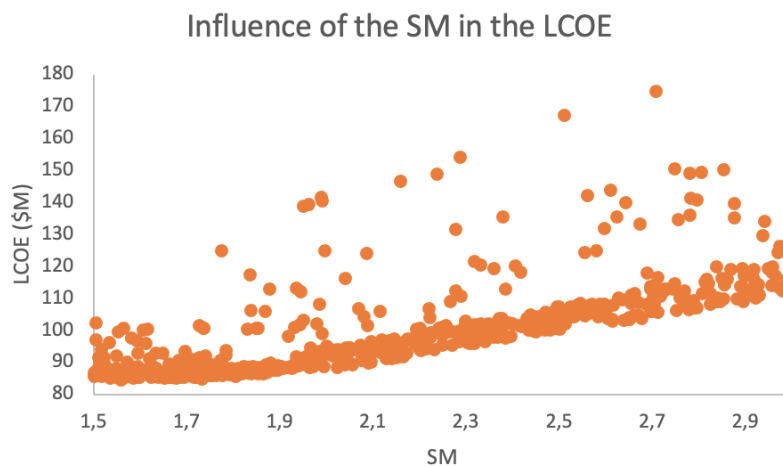

Figure 33: Influence of the SM in the LCOE

<b>PV</b>	197 MW
<b>SM</b>	1,56
<b>hours TES</b>	17,85
<b>Power BESS</b>	25 MW
<b>hours BESS</b>	3 hours

Table 7: Design variables optimized

<b>LCOE</b>	84,4 \$/MWh
<b>CAPEX</b>	600 M\$
<b>OPEX</b>	6,74 M\$ / year
<b>AEY</b>	510,36 GWh
<b>CF</b>	58,26%

Table 8: KPIs optimization

In contrast to the previous case, for the SM parameter in figure 33, we can see a clear trend that the higher the SM, the higher the SM. This is due to the fact that, as already defined, the SM is the quotient between the thermal energy produced in the solar field and the energy needed for the PB. For the same amount of thermal energy for the PB, the higher the SM, the more energy is needed in the solar field, therefore a larger solar field and therefore higher costs.

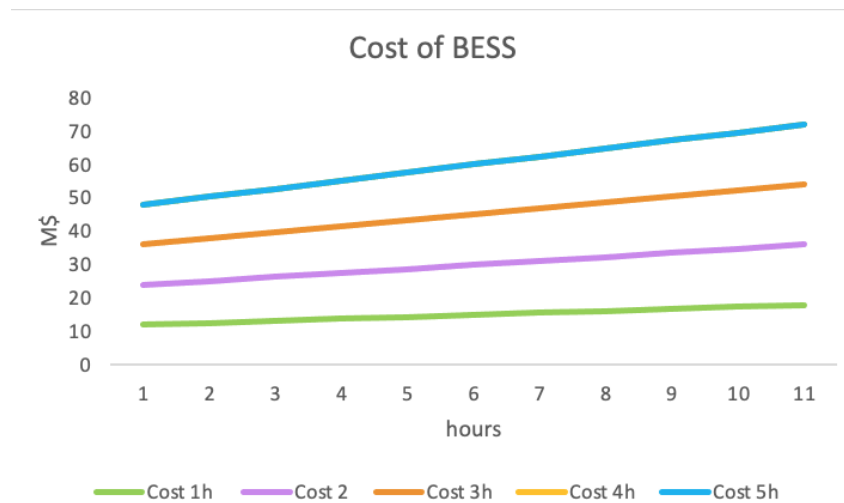

Figure 34: Costs of BESS

In the case of the battery parameters it can be seen in figure 34, in this case, the higher the battery power and the higher the storage hours, the higher the cost, as this is calculated by multiplying the storage hours and power by 600 \$/MWh. Even so, as in the case of the TES parameter, the longer the storage hours, the higher the energy production in the batteries. During optimisation, this parameter has been tested to find the most optimal one, taking into account that it is more or less profitable to use more or less hours of battery energy before starting to use the energy stored in the TES.

The results has been obtained are:



Parameter	Base case	BESS	Optimization	units
LCOE	89,41	93,29	84,4	\$/MWh
CAPEX	583,7	634,5	600	M\$
OPEX	6,9	6,9	6,74	M\$/year
AEY	473,24	486,27	510,36	GWh
CF	51,18	52,6	58,26	%

Table 9: All KPIs

## 5 Conclusions

In this work, we wanted to study one more way of improving the use of one of the most abundant resources in the world, which can be found in practically any country.

For this purpose, a key location has been used, as it is a site of great common radiation, and where there is a lot of interest in creating projects of this type.

The goal of this work, as we will recall, was to study how cost-effective a PV CSP with PV with the addition of electric batteries was. Thermal-packed bed storage and a voltmeter receiver with air as thermal fluid were also used in the plant.

On the one hand, the use of the air receiver and packed bed TES has made it possible to operate at higher temperatures and has increased the efficiency of the power block, which is reflected in the economic parameters.

In addition, the following table compares the economic parameters of the three scenarios:

Looking at the KPI we can see how the model has varied according to the economic scenario.

According to the works hh the LCOE in Morocco in a photovoltaic plant varies between 60\$/MW and 85\$/MW. While the LCOE of CSP is around 185 \$/MW. As explained at the beginning, the advantage of PV is its low cost, which in comparison to the cost of CSP is much higher. Therefore, having this data to compare, it can be concluded that in this work a very competitive LCOE has been obtained, since on the one hand, it is a higher LCOE than could be obtained with a photovoltaic plant alone, but much lower than would be obtained with a CSP plant.

Firstly, if we compare the base case with the addition of the batteries, we can see that the CAPEX has clearly increased, as this represents 10% of the total Capex of the plant, although it also increases the capacity factor. Subsequently, when optimizing, it can be seen that by reducing the SM and increasing photovoltaic generation, despite the fact that storage has increased, it has also been possible to increase production by increasing the capacity factor and therefore achieve better economic results.

It can be said, thanks to the hybrid model with CSP and PV, the decoupling of solar hours to energy generation can be achieved. In other words, electricity can be produced at a low cost during the hours of sunshine thanks to PV. When there are no more hours of sunshine, first of all, electric batteries are used, which although their capital cost is high, is more profitable than turning on the PB, and once the energy stored in these batteries is exhausted, CSP can be used. This way you can have energy all day long, coming from renewable sources and at a competitive price in today's market.

## References

- [1] *Packed-bed thermal storage for concentrated solar power â Pilot-scale demonstration and industrial-scale design* - ScienceDirect. URL: <https://www.sciencedirect.com/science/article/abs/pii/S0038092X12002812> (visited on 11/29/2022).
- [2] *Goals Archive*. The Global Goals. URL: <https://globalgoals.org/goals/> (visited on 11/29/2022).
- [3] *Solar energy*. URL: <https://www.irena.org/Energy-Transition/Technology/Solar-energy> (visited on 11/30/2022).
- [4] *Solar - Fuels & Technologies* - IEA. URL: <https://www.iaea.org/fuels-and-technologies/solar> (visited on 11/30/2022).
- [5] *Concentrating Solar Power*. SEIA. URL: <https://www.seia.org/initiatives/concentrating-solar-power> (visited on 11/30/2022).
- [6] "Renewable Power Generation Costs in 2021 - Executive Summary". In: (2021), p. 4.
- [7] L.G. Pheng et al. "Study the feasibility of Parabolic Dish (PD) from several prospective criteria in Malaysia environment". In: 11 (Jan. 1, 2016), pp. 3929–3937.
- [8] A. Kribus. "Concentrated Solar Power: Components and materials". In: *EPJ Web of Conferences* 148 (2017). Ed. by D. Cahen et al., p. 00009. ISSN: 2100-014X. DOI: [10.1051/epjconf/201714800009](https://doi.org/10.1051/epjconf/201714800009). URL: <http://www.epj-conferences.org/10.1051/epjconf/201714800009> (visited on 11/29/2022).
- [9] *Divaportal.org*. URL: <https://kth.divaportal.org/smash/get/diva2:848781/FULLTEXT01.pdf> (visited on 11/29/2022).
- [10] Bernhard Hoffschmidt et al. "Performance Evaluation of the 200-kWth HiTRec-II Open Volumetric Air Receiver". In: *Journal of Solar Energy Engineering* 125.1 (Jan. 27, 2003), pp. 87–94. ISSN: 0199-6231. DOI: [10.1115/1.1530627](https://doi.org/10.1115/1.1530627). URL: <https://doi.org/10.1115/1.1530627> (visited on 11/29/2022).
- [11] *Oops...* URL: [https://www.brightsourceenergy.com/stuff/contentmgr/files/0/c4b0f3bfc8c003c13f3dfedb0dd31071/attachment/the\\_economic\\_and\\_reliability\\_benefits\\_of\\_csp\\_with\\_thermal\\_storage\\_2014\\_10\\_15\\_final.pdf](https://www.brightsourceenergy.com/stuff/contentmgr/files/0/c4b0f3bfc8c003c13f3dfedb0dd31071/attachment/the_economic_and_reliability_benefits_of_csp_with_thermal_storage_2014_10_15_final.pdf) (visited on 11/29/2022).
- [12] *Thermochemical Energy Storage - an overview* — ScienceDirect Topics. URL: <https://www.sciencedirect.com/topics/engineering/thermochemical-energy-storage> (visited on 11/30/2022).
- [13] Joshua D. McTigue, Christos N. Markides, and Alexander J. White. "Performance response of packed-bed thermal storage to cycle duration perturbations". In: *Journal of Energy Storage* 19 (Oct. 2018), pp. 379–392. ISSN: 2352152X. DOI: [10.1016/j.est.2018.08.016](https://doi.org/10.1016/j.est.2018.08.016). URL: <https://linkinghub.elsevier.com/retrieve/pii/S2352152X18304146> (visited on 11/30/2022).
- [14] *Analysis and optimization of concentrated solar power plant for application in arid climate - Elbeh - 2021 - Energy Science & Engineering - Wiley Online Library*. URL: <https://onlinelibrary.wiley.com/doi/full/10.1002/ese3.742> (visited on 11/29/2022).
- [15] *Solar Photovoltaic Technology Basics*. URL: <https://www.nrel.gov/research/re-photovoltaics.html> (visited on 11/30/2022).

- [16] Nallapaneni Manoj Kumar et al. "Chapter 3 - Solar PV module technologies". In: *Photovoltaic Solar Energy Conversion*. Ed. by Shiva Gorjian and Ashish Shukla. Academic Press, Jan. 1, 2020, pp. 51–78. ISBN: 978-0-12-819610-6. DOI: [10.1016/B978-0-12-819610-6.00003-X](https://doi.org/10.1016/B978-0-12-819610-6.00003-X). URL: <https://www.sciencedirect.com/science/article/pii/B978012819610600003X> (visited on 11/30/2022).
- [17] "Utility-scale batteries â Innovation Landscape Brief". In: (), p. 24.
- [18] *A comparative overview of large-scale battery systems for electricity storage - ScienceDirect*. URL: <https://www.sciencedirect.com/science/article/abs/pii/S1364032113004620> (visited on 11/29/2022).
- [19] *Optimal Design Method of a Hybrid CSP-PV Plant Based on Genetic Algorithm Considering the Operation Strategy*. URL: <https://www.hindawi.com/journals/ijp/2018/8380276/> (visited on 11/29/2022).
- [20] Xing Ju et al. "Recent advances in the PV-CSP hybrid solar power technology". In: SO-LARPACES 2016: International Conference on Concentrating Solar Power and Chemical Energy Systems. Abu Dhabi, United Arab Emirates, 2017, p. 110006. DOI: [10.1063/1.4984480](https://doi.org/10.1063/1.4984480). URL: <http://aip.scitation.org/doi/abs/10.1063/1.4984480> (visited on 11/29/2022).
- [21] Mario Petrollese and Daniele Cocco. "Optimal design of a hybrid CSP-PV plant for achieving the full dispatchability of solar energy power plants". In: *Solar Energy* 137 (Nov. 1, 2016), pp. 477–489. ISSN: 0038-092X. DOI: [10.1016/j.solener.2016.08.027](https://doi.org/10.1016/j.solener.2016.08.027). URL: <https://www.sciencedirect.com/science/article/pii/S0038092X16303644> (visited on 11/29/2022).
- [22] *Analytical model for solar PV and CSP electricity costs: Present LCOE values and their future evolution - ScienceDirect*. URL: <https://www.sciencedirect.com/science/article/abs/pii/S136403211200696X> (visited on 11/29/2022).
- [23] *Global concentrated solar power capacity 2021*. Statista. URL: <https://www.statista.com/statistics/494169/global-installed-concentrated-solar-power-csp-capacity-by-key-country/> (visited on 11/29/2022).
- [24] (PDF) *Genetic Algorithm - an Approach to Solve Global Optimization Problems*. URL: [https://www.researchgate.net/publication/283361244\\_Genetic\\_Algorithm\\_-\\_an\\_Approach\\_to\\_Solve\\_Global\\_Optimization\\_Problems](https://www.researchgate.net/publication/283361244_Genetic_Algorithm_-_an_Approach_to_Solve_Global_Optimization_Problems) (visited on 11/29/2022).