

Student perceptions of a remotely operated motor-driven generator in engineering education

Nicolaas Luwes¹, Leanri van Heerden², Walter Commerell³

¹Centre for Sustainable SMART Cities, Central University of Technology, Bloemfontein, South Africa, ²E-Learning and Educational Technology Central University of Technology, Central University of Technology, Bloemfontein, South Africa, ³Institute for Energy Technology an Energy Economics University of Applied Sciences Ulm – Technische Hochschule Ulm, Ulm, Germany.

Abstract

Smart technologies in engineering education provide students with relevant real-world experience and safeguard the quality of instruction during emergency remote teaching. This paper aims to have students complete a motor-driven generator practical via a RemoteLab and measure their perceptions of the experience. A survey was conducted with five-point Likert scale questions asking students to indicate their satisfaction with the useability and effectiveness of the RemoteLab, then given a list of action verbs from Gloria Willcox's feeling wheel to select what best described their emotions during the exercise, and finally open-ended questions to expand on their experience. Results showed students found the system easy to use and effective and most felt joyful and powerful emotions during the exercise. There was some indication that they still preferred contact sessions on campus which shows that a RemoteLab may be best used as an intervention when the contact mode of delivery is suddenly disrupted.

Keywords: *Engineering education; RemoteLab; online learning; Gloria Willcox feeling wheel; (4IR) Fourth Industrial Revolution.*

1. Introduction

Engaging students hungry for new experiences have become a challenge in an online teaching and learning environment, especially in subject fields where practical experience is dependent on working with expensive, or hard-to-come-by, tools and machinery. Practical experience is crucial for deeper learning and building student confidence (Bradberry & De Maio, 2019). Engineering students studying renewable energies need to experience the relationship between their theoretical lectures and practical laboratory exercises to fully assimilate the new skills. Renewable energies have large variants in test conditions, thus field tests on systems are often analysed under real-world conditions in research and training.

Distance laboratories as teaching tools were becoming more widely used for imparting practical skills to students in online teaching and learning delivery but saw an enormous boost in the field of e-learning in education during the COVID-19 pandemic when universities and other institutions of learning, were forced to shift their delivery to online environments (Gamage, et al., 2020). Creating a laboratory that allows students to practice their newly acquired theoretical knowledge in real-world conditions requires smart technology that enables a user to remotely control the machinery in the laboratory from any location over a network. The fourth industrial revolution uses modern smart technology in the automation of traditional and modern manufacturing including the Internet of Things (IoT). IoT is a new technology paradigm thought of as a global network of machines and devices that can interact with each other, bridging the gap between the world of the Internet and our physical plane (Kumar, Tiwari, & Zymbler, 2019). The development of IoT protocols can be used in the construction and implementation of a RemoteLab.

For this paper, the two universities – the Technical University of Ulm (THU), Germany and the Central University of Technology (CUT), South Africa – collaborated on developing a didactic concept RemoteLab that allows students access to the prototype motor-driven generator from any location via the Internet. Students from both universities used the RemoteLab and were subsequently asked to complete a questionnaire gathering their perceptions of the experience. The students' perceptions of the useability of the system will assist the lecturers in shaping and improving the RemoteLab. Gathering perceptions as qualitative data will help the researchers answer their research question on how students feel about using a motor-driven generator in the RemoteLab and more richly describe the human experience (Paradis, O'Brien, Nimmon, Bandiera, & Martimianakis, 2016).

This paper will first review relevant literature on practical experience in an online environment, the RemoteLab, and describe participant attitudes. Then the method underpinning the research is discussed after which the paper is closed with the results of the survey and the conclusions drawn from the data.

2. Literature Review

Online practicals can be performed either by virtual or remote laboratories. In the case of virtual the exercise is simulated via a computer whereas, in a remote laboratory, the physical operation runs in real-time and only the control thereof is facilitated by a computer which can be in a different geographic location connected to a network accessed by the user (Mohammed, El Zoghby, & Elmesalawy, 2020). For the engineering lecturer, a remote laboratory is preferable as the student experiences the operation actively and is not only an observer as the simulation runs through the operation. Practicing with the physical machine/tool, albeit from different a location, allows the student to problem-solve and troubleshoot on the spot which enriches the learning experience. It allows students the opportunity to work with machines/tools that they may otherwise not have access to, like the motor-driven generator used in this paper.

It can be difficult for students to describe how they are feeling about classwork as emotions can be deemed as separate from a “work” state of mind. As the engineering field often attracts people with a more analytical mindset this is especially true for engineering students. The Gloria Willcox feeling wheel, was inspired by Joseph Zinker's and Robert Plutchik's comparison of emotions to colors but adjusted to action verbs, can be used to frame questions with the correct vocabulary so that participants can identify their feelings regarding the specific experience (Willcox, 1982). Gloria Wilcox developed action words linked to feelings in a wheel diagram using the four basic emotions: scared, sad, mad and glad but with glad expanded into joyful, powerful, and peaceful (Zinker, 1978) (Plutchik, 1982). These action words can be used to frame survey questions and so assist the participant with putting a name to the emotion they experienced.

3. Methodology

The development and implementation of RemoteLab motor-driven generator using Google cloud can be seen below:

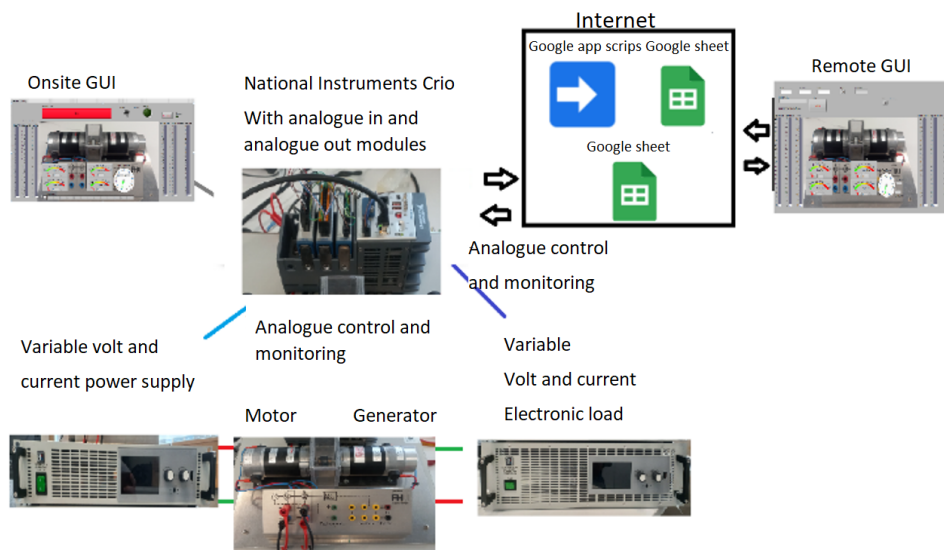

Figure 1. The final prototype RemoteLab

The prototype RemoteLab is built on a typical motor-driven generator lab experiment. The user would adjust the variable power supply and variable load as indicated in the experimentation documentation. In the prototype RemoteLab this was replaced by controlling the inputs via a LabVIEW CRIO and the electronic control inputs of the supply and load via new custom software. The new Human-Machine Interface (HMI) can be controlled onsite and a second digital twin HMI with the same look and feel was programmed that can be controlled online. The Google cloud space is the backbone or in-between to the remote twins and the main controller. Of these servers, Google sheets and Google scripts were used.

An exploratory study is employed along with descriptive statistics involving quantitative analysis of the collected data. Data was collected with surveys using five-point Likert scale questions measuring students' perceptions of the RemoteLab experience, from being "Not satisfied at all" to being "Extremely satisfied". The Likert scale, developed in 1932, is still widely used today to measure participant attitudes. From the five- or seven-point scale the participant can select their strength of feeling, for example whether they agree or disagree with the statement (Joshi, Kale, Chandel, & Pal, 2015).

Student perceptions of the learning environment can be predictive of learning and indicative of motivation to learn (Wallace, Kelcey, & Ruzek, 2016). Participants were then given the opportunity to select multiple feeling wheel action verbs in response to the question: "Which of the following emotions would you say you felt while working on your generator remotely?" to gauge their emotional mindset during the exercise.

As stated, the RemoteLab prototype was built by converting a typical motor-driven, generator lab experiment to an online RemoteLab prototype with local and online HMI's. The prototype was evaluated by a sample group of 10 students, selected by asking for volunteers from both the German and South African cohorts. They were asked to do the typical experiment using the online prototype RemoteLab. The hardware is stationed in the German ULM campus and German and South African students were accessing it from their homes and/or a computer facility on the respective campuses. After the experiment was completed, the sample was asked to do a perception survey via Google Forms. Ethical clearance was obtained for the survey.

4. Results

Out of the 10 participants, 8 were from the CUT, and 2 were from ULM. Of these, 40% were between the ages of 26 and 30, and 60% were between 18 and 25. Being all under the age of 30 one would expect a certain amount of tech-savvy, but 80% indicated that they have never worked in a RemoteLab before.

Results indicated that the RemoteLab useability (labeled as very easy, easy, normal, hard, very hard) bell-curved with 10% saying it was very easy and 40% indicating it was easy to use, with the other 50% stating normal, no hard or very hard.

Perceptions delivery mode 60% of students preferred to have hands-on classes with both the lecturer and peers in the same location. So even though they found the RemoteLab easy to use, they still preferred the traditional contact sessions.

The satisfaction pole on the ability to still test their theoretical knowledge in a practical exercise even when remote, (labeled as extremely satisfied, satisfied, neutral, dissatisfied, not satisfied at all) the majority responded to being satisfied with the bell curved from normal to extremely satisfied.

Perceptions, from the sample, on working with the physical equipment remotely indicated a bell curve toward more satisfied. Working with the actual hardware is a positive experience as renewable energy experimentation, in its nature, has large variants in test conditions that are not always possible with simulation or purely theoretical calculations. This tends to aid in learning if students see the external and environmental factors producing a deviation in theory calculations.

As stated in the normal operation of the experiment students would have had to manually change the variable power supply and variable load. For it to be a RemoteLab, this system needed to be automated first, with a new window HMI. Perceptions from the sample on the new graphic interface saw the curve leaning to satisfied and extremely satisfied but with some neutral and even one dissatisfied indicated, which needs to be investigated.

The following questions and results were designed using the feeling wheel.

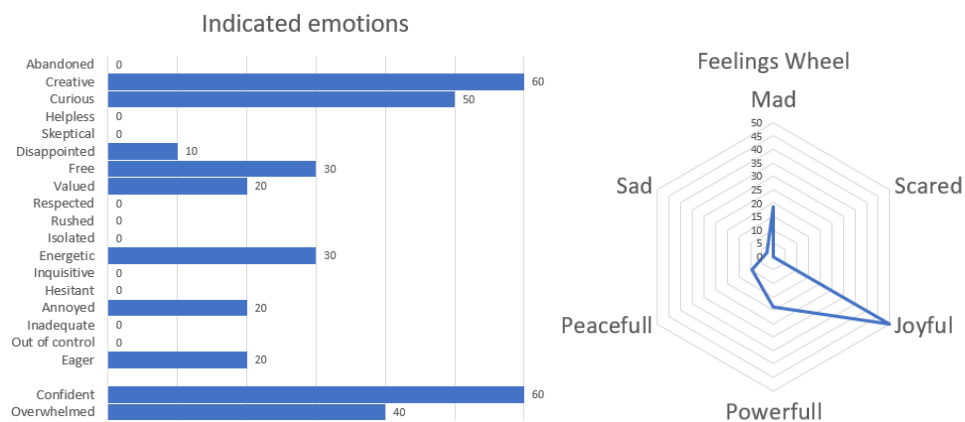

Figure 2. Recorded emotions from participants and interpreted to the feelings wheel

Most of the area occupies the ‘joyful’ to ‘powerful’ section, with a smaller area covered in the ‘scared’ and ‘mad’ sections. The negative emotions could be ascribed to this, being most of the participants’ first attempt at a practical exercise in a RemoteLab, which may have caused frustration while learning to navigate the new environment. Note that mostly positive feelings were recorded, thus the minority indicated frustration should cause too much of a concern, but a solution could be that more technical training on the use of the remote system is perhaps needed before the exercise is undertaken in the future.

The survey was concluded with some open-ended questions to allow participants space to expand on their experience. To see if learning took place the question: “Do you think it’s important to test your theory on real world physical equipment? Motivate.” was asked. The sample mostly replied yes with some indicating the following: “Yes, for us to have more accuracy and have proof of what is calculated theoretically can also be achieved remotely”, “Yes, it helps to put theory into practice while in turn gauge one’s understanding of the work.”, “Definitely, because everything you’ve learned you need to practice it in the real world”

The question: “How do you see the difference between a software simulator and a remote physical system for experimentation?” was asked to see if the sample could distinguish between a simulator and a remote laboratory, and most were able to as seen in the following excerpts: “Remote physical systems give you the real-life experience or expectation”, “With the remote physical system we can see the actual machinery and hear a sound in the background unlike on the simulator”, “Physical systems will be more accurate, since it allows for the practical variable”. Some apprehension was also recorded with one participant

stating that: *“The only difference is that with a remote physical system one is more cautious as one wrong move could blow the machine”*. This answer shows a need for instructing the students on possible issues and troubleshooting to instill confidence. One participant preferred the simulation stating: *“It is interesting that there is a real object running at the other end but if the simulation would run with fewer lags, I would prefer the simulation”* which suggests further investigation into the use of simulators may yield valuable insight.

Participants also showed a sense of the exercise’s value, when asked for “Any comments?”, one stated gratefully: *“Thank you for organizing the remote Lab experience it was a great exposure to see how remote-control machinery can be done as we are in the 4IR era.”* And another wrote: *“This opens a door for a lot of possibilities, to a place that has limited resources for students to learn and expand their understanding of theory content.”*

5. Conclusion

The purpose of this paper was to gauge engineering students’ perceptions of using a RemoteLab to operate a motor-driven generator. Perceptions were gathered with a survey conducted after the experience. The survey used five-point Likert scale questions to determine the students’ satisfaction with the useability and effectiveness of the RemoteLab. Then the students’ emotional mindset during the exercise was determined by asking them to select feeling wheel action verbs from a list that most described their emotions. Finally, they were given the opportunity to expand on their experience with open-ended questions.

The Likert scale questions indicated a high level of satisfaction with the system and that students found it easy to use and effective. However, when asked about their preference between the RemoteLab and the traditional contact sessions, the majority were inclined toward a physical class in the same location as the lecturer and their peers. Most students selected joyful and powerful from the feelings list, indicating a positive mindset overall, with some mentioning feeling scared and mad, most likely due to it being their first RemoteLab experience. During the open-ended questions, most responses were positive and showed that students were ready to use the RemoteLab when necessary. The following quote from one participant represents the general feeling best: *“The experience was amazing, and I hope to do it again”*.

This paper showed that RemoteLabs, like other 4IR technologies, can be useful in engineering education when circumstances force remote learning, but that students would still prefer the on-campus contact sessions with the lecturer and peers. The use of the feeling wheel to gauge emotional state during the exercise gives valuable insight into the mindset of the students during this new experience and along with the data from the Likert and open-ended questions will help the lecturer improve their teaching and learning practice and better prepare the curriculum for possible future disruptions, like the past COVID-19 pandemic.

References

- Bradberry, L. A., & De Maio, J. (2019). Learning by doing: The long-term impact of experiential learning programs on student success. *Journal of Political Science Education*, 15(1), 94-111. doi:<https://doi.org/10.1080/15512169.2018.1485571>
- Gamage, K. A., Wijesuriya, D. I., Ekanayake, S. Y., Rennie, A. E., Lambert, C. G., & Gunawardhana, N. (2020). Online delivery of teaching and laboratory practices: Continuity of university programmes during COVID-19 pandemic. *Education Sciences*, 10(10), 291-299. doi:10.3390/educsci10100291
- Joshi, A., Kale, S., Chandel, S., & Pal, D. K. (2015). Likert Scale: Explored and explained. *Current Journal of Applied Science and Technology*, 7(4), 396-403. doi:10.9734/BJAST/2015/14975
- Kumar, S., Tiwari, P., & Zymbler, M. (2019). Internet of Things is a revolutionary approach for future technology enhancement: A review. *Journal of Big data*, 6(1), 1-21. doi:<https://doi.org/10.1186/s40537-019-0268-2>
- Mohammed, A. K., El Zoghby, H. M., & Elmesalawy, M. M. (2020). Remote controlled laboratory experiments for engineering education in the post-COVID-19 era: Concept and example. *2nd Novel Intelligent and Leading Emerging Sciences Conference* (pp. 629-634). Giza: IEEE Xplore. doi:10.1109/NILES50944.2020
- Paradis, E., O'Brien, B., Nimmon, L., Bandiera, G., & Martimianakis, M. A. (2016). Design: Selection of data collection methods. *Journal of Graduate Medical Education*, 8(2), 263-264. doi:10.4300/JGME-D-16-00098.1
- Plutchik, R. (1982). A psychoevolutionary theory of emotions. *Social Science Information*, 21(4-5), 529-553. doi:<https://doi.org/10.1177/053901882021004003>
- Wallace, T. L., Kelcey, B., & Ruzek, E. (2016). What can student perception surveys tell us about teaching? Empirically testing the underlying structure of the tripod student perception survey. *American Educational Research Journal*, 53(6), 1834-1868. doi:<https://doi.org/10.3102/0002831216671864>
- Willcox, G. (1982). The feeling wheel: A tool for expanding awareness of emotions and increasing spontaneity and intimacy. *Transactional Analysis Journal*, 12(4), 274-276. doi:<https://doi.org/10.1177/036215378201200411>
- Zinker, J. (1978). *Creative process in gestalt therapy*. New York: Vintage Books.