



UNIVERSIDAD
POLITECNICA
DE VALENCIA



Máster Universitario
en Tecnologías, Sistemas y
Redes de Comunicaciones

Application of MIH for the Lightweight Deployment of LTE-Advanced Systems through Mobile Relaying

Autor: Pablo Gualda Romero

Director: Jose Francisco Monserrat del Río

Fecha de comienzo: 01/10/2011

Lugar de trabajo: Grupo de Comunicaciones Móviles del iTEAM

Objetivos

Esta tesina de máster tiene tres objetivos principales. El primero de ellos consiste en evaluar el uso del *relay* móvil basado en la tecnología 802.11n en redes de comunicaciones móviles de cuarta generación. Un problema importante de este tipo de despliegues radica en el enrutamiento, por ello el siguiente objetivo es diseñar un mecanismo de enrutamiento para la gestión del *relay* móvil en redes LTE-Advanced. Finalmente, el último objetivo es evaluar los beneficios tanto a nivel de prestaciones de red como a nivel económico que conlleva el uso de *relays* móviles en una red LTE-Advanced.

Metodología

Se ha desarrollado un simulador que permitiera llevar a cabo las pruebas pertinentes. Una vez desarrollado se han realizado distintas simulaciones abarcando una amplia variedad de escenarios. En estos escenarios se ha procedido a variar una serie de parámetros que caracterizan diferentes situaciones de trabajo del *relay* móvil. Esto ha permitido la obtención de unos resultados fiables y concluyentes en el proceso de evaluación del impacto del *relay* móvil en la implantación de una tecnología novedosa como es el caso de LTE-Advanced.

Desarrollo de prototipos y trabajo de laboratorio

Se ha procedido a desarrollar un simulador de redes de los niveles superiores del modelo de capas OSI (Aplicación, transporte e IP). Para llevar a cabo esta implementación, se ha hecho uso del lenguaje de programación orientado a objetos C++. Mediante la simulación de múltiples interfaces radio se ha procedido a realizar el enlace con el nivel físico de la red. El nivel de capa física ha sido implementado en el caso de 802.11n mientras que para LTE-Advanced se ha hecho uso del simulador SPHERE (*Simulation Platform for Heterogeneous wireless systems*), una plataforma de simulación a nivel de sistema desarrollada por el grupo de comunicaciones móviles del instituto iTEAM. Mediante el uso de *Look-up Tables* pre-calculadas en SPHERE se ha podido realizar la simulación del enlace y gestión de recursos radio de una red 4G. Para la gestión del enrutamiento a través de *relays* se ha desarrollado el método MIDRES (*MIh Driven RELay Selection mechanism*) basado en el estándar IEEE 802.21 (*Media Independent Handover*). Éste estándar está concebido para la gestión de *handovers* inter-tecnología entre distintos puntos de acceso. Sin embargo, por su versatilidad y aplicabilidad a nuestro caso, ha sido escogido para manejar el enrutamiento de *relays* móviles.

Resultados

Con los resultados obtenidos se demuestra el beneficio del uso del algoritmo MIDRES para el enrutamiento de *relays* móviles en redes 4G. La obtención de resultados se centra principalmente en el análisis de prestaciones. Este análisis se realiza a través de medidas como el MUT (*Mean User Throughput*) o el CEUT (*Cell-Edge User Throughput*). A partir de ésta última se ha procedido a establecer un criterio mínimo de calidad que permite fijar la extensión de cobertura de celda que se puede obtener mediante el uso de *relays* móviles en redes LTE-Advanced. Esta extensión de cobertura permite reducir el número de *enodeBs* necesarios para ofrecer cobertura 4G a una región determinada. La reducción del número de *enodeBs* necesarios, como se demuestra en el apartado de resultados, redonda en un gran ahorro económico para las operadoras de redes de telecomunicaciones.

Líneas futuras

A pesar de haber obtenido resultados positivos en la evaluación de *relays* 802.11n, la tecnología WiFi tiene una serie de inconvenientes y limitaciones que se ven reflejados en el sistema planteado. Las restricciones inherentes a la tecnología 802.11 serían minimizadas mediante el uso de *relays* basados en LTE-Advanced. El uso de este tipo de *relays*, además de los beneficios que ofrece la tecnología LTE-Advanced per sé en cuanto a *throughput* y calidad de servicio, permite reducir el gasto de potencia requerido puesto que puede realizarse todo el proceso mediante una única interfaz radio. Esta interfaz deberá, o bien gestionar sus propios recursos en lo que se conoce como *relays* no transparentes, o por otro lado recibir a través de los canales de control correspondientes la asignación de recursos del *enodeB* al que se encuentre asociado. Este segundo tipo de *relay* se denomina *relay* transparente. Otra importante línea de investigación a seguir radica en la gestión de la cooperación entre nodos de cara a prestar servicio de *relay* móvil. En la actualidad la comunidad científica está proponiendo y estudiando distintos métodos sin haber llegado a una conclusión clara.

Publicaciones

Se ha publicado un artículo en revista ubicada en segundo tercio por factor de impacto:

J.Cabrejas, P.Gualda, J.F.Monserrat and D.M-S. Gandía, *Application of MIH for the lightweight deployment of LTE-advanced systems through mobile relaying*, EURASIP Journal on Wireless Communications and Networking, 2012.

Abstract

En las redes de comunicaciones móviles clásicas, el modo de funcionamiento normal es el basado en las conexiones directas entre los equipos terminales de usuario con las estaciones base. En esta tesina de máster nos centramos en el modelo de comunicación basado en *relay* móvil (MR – *Mobile Relay*) en el que una estación base puede establecer la comunicación con un nodo móvil de su red a través de otro. Estos nodos constituyen una red ad-hoc WiFi cuya comunicación hay que gestionar. La conexión Estación base-Nodo *relay* se realiza mediante LTE-Advanced y el enlace Nodo *relay*-Nodo destino a través de la conexión WiFi ad-hoc. Para gestionar el enrutamiento en el sistema propuesto se ha desarrollado el algoritmo MIDRES, basado en el estándar IEEE 802.21 (MIH) que permite, a través de una serie de entidades, mensajes y primitivas, manejar la carga de red relativa al enrutamiento de manera eficiente, rápida y con una reducción de las tasas disponibles por los usuarios casi imperceptible para los mismos. Los nodos existentes en la red envían mensajes MIH notificando una serie de eventos (como caídas de SNR por debajo de un determinado umbral) para así conmutar entre el modo de conexión clásico y el modo *relay*. El diseño del mecanismo de señalización, el estudio de los umbrales, la evaluación del funcionamiento del sistema planteado, junto con las ventajas económicas de su uso constituyen los principales aspectos del trabajo realizado.

Autor: Pablo Gualda Romero, email: pabguaro@iteam.upv.es

Director: Jose Francisco Monserrat del Río, email: jomondel@iteam.upv.es

Fecha de entrega: 01-06-12

INDEX

I. Introduction 1

 I.1. Technologies..... 1

 I.2. State of the Art..... 1

 I.3 Proposal 2

II. Current Technological Scenario..... 3

 II.1. LTE-Advanced 3

 II.2. IEEE 802.11n 4

 II.3. Media Independent Handover 4

 II.4. Localization..... 5

III. MIH-Driven Relay Selection Mechanism (MIDRES) 6

 III.1. Situation 1 8

 III.2. Situation 2 11

 III.3 Situation 3 12

IV. Assessment Methodology and System Modeling 12

V. Simulation tools 14

 V.1. SPHERE..... 14

 V.2. SPHERE New Generation 16

 V.3. Complete Simulation Tool..... 17

 V.4. Validation of Simulation tool..... 17

 V.4.1. Validation Scenario..... 17

 V.4.2. Validation results 18

VI. Results and Discussion 21

 VI.1. Threshold evaluation 21

 VI.2. Performance evaluation of the Relay Discrimination Algorithm (RDA)..... 24

 VI.3. Velocity impact evaluation in performance..... 25

 VI.4. Deployment cost in a LTE-A system 26

VII. Conclusions 28

VIII. Future Work 29

IX. References..... 30

FIGURES INDEX

Fig. 1 Media Independent Handover Operation 5

Fig. 2 Scenario under study 7

Fig. 3 MIDRES Procedure to configure a MR 9

Fig. 4 MIDRES procedure to change MR 11

Fig. 5 SPHERE simulator structure 15

Fig. 6 SNG relay communication structure 16

Fig. 7 CDF for InH scenario 19

Fig. 8 CDF for UMi scenario 19

Fig. 9 CDF for UMa scenario 20

Fig. 10 CDF for RMa scenario 20

Fig. 11 Threshold analysis for InH (left) and UMi (right) scenarios 22

Fig. 12 CDF of the mean user throughput for InH (left) and UMi (right) scenarios 23

Fig. 13 Threshold analysis for UMa (left) and RMa (right) scenarios 24

Fig. 14 Mean user throughput for different R_{RDA} values in a UMa scenario 25

Fig. 15 Mean user throughput for different values of MN speed in the UMa scenario . 26

Fig. 16 Cell-edge user throughput versus cell radius with different percentages of cooperative nodes 27

TABLE INDEX

Table 1. Basic parameters used in the performance assessment 14

Table 2 Validation scenario conditions 17

Table 3 ITU-R 2135 Validation Scenario Recommendations 18

Table 4 Cell-edge comparison for different validation scenarios 21

Table 5 CEUT for different Th_{LTE} 22

Table 6 Cost analysis of the LTE-A deployment 28

I. Introduction

1.1. Technologies

The volume of data traffic has increased significantly in recent years. In fact, in December 2009 for the first time in history, the volume of worldwide voice traffic was below data traffic [1]. Extrapolating this trend, it is estimated that by 2020 data traffic will be the dominant in mobile communications primarily due to the proliferation of applications like video streaming. With the purpose of solving the need of this amount of data traffic, technologies as Long Term Evolution Advanced (LTE-A) [2] or Worldwide Interoperability for Microwave Access (WiMAX) [3] has been developed and standardized. For being considered as fourth generation technologies, LTE-A and WiMAX are very demanding in terms of quality of service. Data rates above 1 Gbps with bandwidths of up to 100 MHz for low mobility users and 100 Mbps for high speed users [4] must be delivered for being classified as 4th generation technology. Given the high data rates specified in the standard, a national-wide deployment of base stations (BS) could be extremely costly for operators. The use of mobile relays (MR) can be a good alternative for reducing the cost of the network deployment. An optimized and well designed deployment of BS assisted with MRs can give a similar performance as a network covering the same area with a higher number of BS.

1.2. State of the Art

The use of fixed cooperative relays has already been introduced in WiMAX Mobile and 3GPP (Third Generation Partnership Project) LTE-A standard. Although the results are valid for both systems, this document is focused on the 3GPP solution.

A further step towards full integration of relaying is the use of mobile terminals as relays, which is known as mobile relaying. In [5], Xiao *et al.* studied the usage of MRs to extend coverage and increase throughput. Results showed an increase in coverage ranging from 21% to 44% depending on the distance from Mobile Node (MN) to the BS, and an increase in maximum throughput from 20% to 60% depending on the transmission power and the path loss exponent. In [6], Vanganuru *et al.* proposed the use of a hybrid wireless network with direct radio links between MNs. The BS chooses the best relay to maximize the throughput of each radio link. This mechanism results in average throughput gains of

40% assuming capacity is calculated with Shannon formula and regardless of the cost of signaling in the selection of the best relay.

Concerning the motivation of users to collaborate as MRs, there is a lot of literature addressing different ways to reinforce this cooperation (see e.g. [7]). Among other strategies, [7] presents the idea of reputation in which users cooperate to increase their status and, consequently, they are aided in the moments in which they need the support of another MR.

However, the optimal relay selection is of great importance and signaling overhead cannot be underestimated. An optimal routing mechanism must be defined so as it can dynamically adapt to changes in the system while involving the least possible signaling overhead. To date, the LTE-A standard only contemplates the use of fixed relays and lack any mechanism of MR selection.

Within this framework, this master thesis proposes the use of IEEE 802.21 Media Independent Handover (MIH) standard to support the relay selection process. MIH standard is an application protocol that can be easily implemented on mobile and network devices. MIH defines a set of entities and messages that have local and remote reports on link status so that decisions can be made dynamically in the access network. Besides it provides intelligence to both the physical and Medium Access Control (MAC) layers and network information to upper layers [8]. Initially, this standard was designed to optimize handovers in heterogeneous networks. In [9], Bae *et al.* proposed to use MIH signaling to support a triggering mechanism for the management of vertical handovers based on the data rate. On the other hand, Seol and Chung proposed to conduct vertical handover between LTE and WiMAX by adding some new nodes in the core network with a MIH Function entity (MIHF) [10]. The work from Bultmann *et al.* [10] addressed handover signaling and introduced discovering capacity and some procedures for handover in heterogeneous networks assuming LTE assisted with fixed relays. It is worth noting that MIH signaling was only used to make handovers between BSs of different networks rather than to select relays.

1.3 Proposal

This master thesis proposes a new application of MIH signaling to the management of multiple radio interfaces in a cellular system assisted with MRs. The system scenario comprises an LTE-A network where MNs have another WiFi radio interface for ad-hoc

communications. This assumption is fully aligned with current technological trends since both radio interfaces are expected to coexist in coming mobile devices. This document aims at analyzing the signaling requirements and provides not only an optimal configuration but also mechanisms for reducing the overhead. Moreover, it is analyzed to what extent mobile relaying can support the deployment of lightweight networks.

II. Current Technological Scenario

In order to use MIH signaling to manage the routing of packets dynamically it is necessary to define a set of technological tools that support the proposed solution. The following sections define the basis of these technologies.

II.1. LTE-Advanced

4G cellular systems are being designed to increase the coverage and user data rates. The spectrum for 4G systems can be distinguished into five bands: the 450 MHz band, the Digital Dividend (DD) band around 700 MHz (spectrum available after the switchover from analogue to digital television), Advanced Wireless Services (AWS) band between 1.7-2.1 GHz, the 2.5 GHz band and, finally, the C band around 3.5 GHz [11] As can be seen, most of these bands are above 2 GHz, where propagation loss exponent is higher and therefore, under these conditions, traditional cellular architectures require a higher density of BSs. Obviously, increasing the density of BSs is very costly for operators and other alternatives are preferred. One solution may be to increase the allocated bandwidth or spectral efficiency. Indeed, in later sections of this document it is shown how mobile relaying implies a significant increase in spectral efficiency.

In a relay scenario there are three types of link: a BS to user link, a BS to relay link (also known as backhaul) and a relay to user link. It is worth noting that the relay node is wirelessly connected to the radio access network through the BS or donor cell. 3GPP distinguishes two types of architectures [12] focusing on fixed relays.

- **Architecture A.** This architecture is based on the termination at the relay of both U-Plane and C-Plane protocols of the S1 interface. In this proposal the relay can be seen as a BS for the user.
- **Architecture B.** In this case the donor BS terminates S1 connections towards Evolved Packet Core (EPC) and the relay node can be seen as a cell managed but the donor BS from the EPC and neighbor BSs point of view. In this

architecture, some legacy MAC/RLC/PDCP protocols would need to be modified.

II.2. IEEE 802.11n

One of the most pervasive wireless technologies for use in homes, offices, and other multiple scenarios is the IEEE 802.11 technology. 802.11n is the version that offers more peak data rate, reaching more than 100 Mbps. The used bandwidths are 20 or 40 MHz in the bands of 2.4 or 5 GHz [13]. The physical layer data rate can even exceed 300 Mbps provided 2 x 2 spatial multiplexing and 40 MHz bandwidth. This high performance is achieved through a range of new technological solutions such as: Multiple Input Multiple Output (MIMO) schemes, Spatial Multiplexing (SM), spatial mapping (including beamforming), Space-Time Block Coding (STBC) and Low-Density Parity Check (LDPC) coding.

II.3. Media Independent Handover

The IEEE 802.21 MIH is specially designed to perform handovers between different IEEE 802 architectures (802.3, 802.11 and 802.16) [8]. However, other 3GPP technologies such as LTE-A can be included in its operation. Next generation handsets are ideal candidates for installing and using the protocol since they have multiple radio access interfaces (UMTS, LTE, WiFi, etc). Moreover, MIH protocol can easily be included in the application layer.

Mainly, MIH is based on the exchange of messages reporting a subset of PHY/MAC layer events. The MIH functions are enabled by an entity called MIH function (MIHF), which provides MIH Event Services (MIES), MIH Command Services (MICS), and MIH Information Services (MIIS). Fig. 1; **Error! No se encuentra el origen de la referencia.** shows the main entities in the MIH protocol as well as the events and commands generated by these entities. The MIES detects changes in the link layer and initiates events from both local and remote interfaces. The MICS offers the MIH-User control over the connection properties that are relevant to the handover. Finally, the MIIS provides information on different heterogeneous networks. There are specific events to notify link power going down, link disconnection, degradation of the channel link, handover is imminent, and so on.

The different events and commands are defined in the MIH standard. Depending on where the information is originated, the MIHF entity could receive or transmit reports on

the configuration and condition of the radio access networks the MN is detecting. If the information is obtained remotely, the local MIHF entity receives information from the remote MIHF entity that is located in the network. However, when information is received from the lower layers of the protocol stack, this is obtained through service primitives that define the interface. For example, if the signal strength received by a remote entity falls below a threshold, the lower layers detect it and send a Link Going Down event to the MIHF entity. This entity communicates with the remote MIHF through Remote MIH Events. Once the event reaches the local MIHF entity, it is forwarded via a MIH event to the MIH-User. In the same way as with events, local MIH-User can send a command to make lower layers perform a specific operation. For example, thresholds can be adjusted, the active link quality can be measured in terms of Signal to Interference plus Noise Ratio (SINR), Bit Error Rate (BER), etc. Finally to integrate MIH within 3GPP systems there is no need for new protocols to access MIHF services. These services can be mapped to those already existing in 3GPP [8].

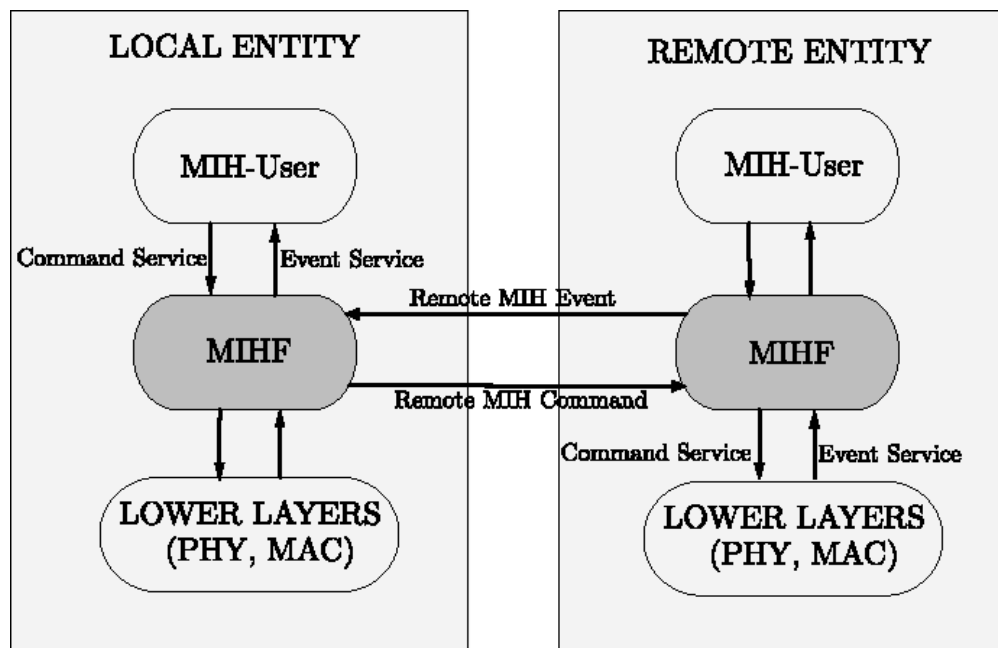

Fig. 1 Media Independent Handover Operation

II.4. Localization

User positioning can significantly reduce the complexity of the relay selection process. LTE-A specification considers MN localization through the LTE Positioning Protocol (LPP) and LPP Annex (LPPa) [14][15][16]. Several different positioning methods are mentioned in the standard, namely: Observed Time Difference of Arrival (OTDOA),

Assisted-Global Navigation Satellite System (A-GNSS) and Enhanced-Cell ID (E-CID). Implementation details are omitted here but the interested reader can refer to the standard for further information. All of these positioning methods are based on measurements collected by the MN or the BS. The Mobility Management Entity (MME) is the entity that receives the request for the localization of a MN from another entity such as a MN, BS or other nodes. Then, the MME sends a location service request to the Enhanced Serving Mobile Location Centre (E-SMLC) that will execute the positioning procedure through LPP and LPPa protocols. The S1-M Interfaces defined between E-SMLC and MME serves as a tunnel for the E-SMLC to transparently carry LPP and LPPa protocols through the MME, in addition to transport the Location Services Application Protocol (LCS-AP) messages and parameters. The study of different positioning methods is outside the scope of this master thesis. However, it worth noting that LTE-A location methods are available and can be used by the relay selection mechanism proposed.

Concerning the signaling overhead of user positioning, note that the periodicity of LPP methods must be higher than 0.5 s, which is the typical period of measurement reports sent by Long Term Evolution (LTE) mobile nodes. Considering that the MIIS entity is independent for each BS, the data base burden is limited to hundreds of inserts per second, which is an order of magnitude lower than the current capacity of commercial data bases.

III. MIH-Driven Relay Selection Mechanism (MIDRES)

Users located in the cell-edge suffer a reduction in data rates as compared with users that are close to the BS. This fact is due to the lower SINR of cell-edge users. This causes some unfairness among nodes because of their location. Moreover, considering that the spectral efficiency requirements set by the International Telecommunication Union (ITU) for 4G technologies are very demanding [11], both IEEE and 3GPP have decided to use relays to increase the cell-edge user spectral efficiency. The use of relays improves the transmission range, increasing the probability of receiving the data correctly and allowing higher data rates than those achieved without relays.

Fig. 2 shows the scenario under study. Three types of nodes are distinguished: a BS, MNs and MRs. The user that is experiencing bad channel conditions is referred to as Solicitor Mobile Node (SMN). In this scenario there exist MNs receiving from the BS (active nodes) and MNs in idle mode (passive nodes), which are the only ones that can relay signals from the SMN. Both MNs and MRs have two interfaces: an LTE-A interface

to communicate directly with the BS and a WiFi interface for the MN to MR link. It is considered that the link between the MR and the MN is implemented with IEEE 802.11n standard [13]. At baseline, all MNs are connected with LTE-A unless the use of mobile relaying implies higher data rates.

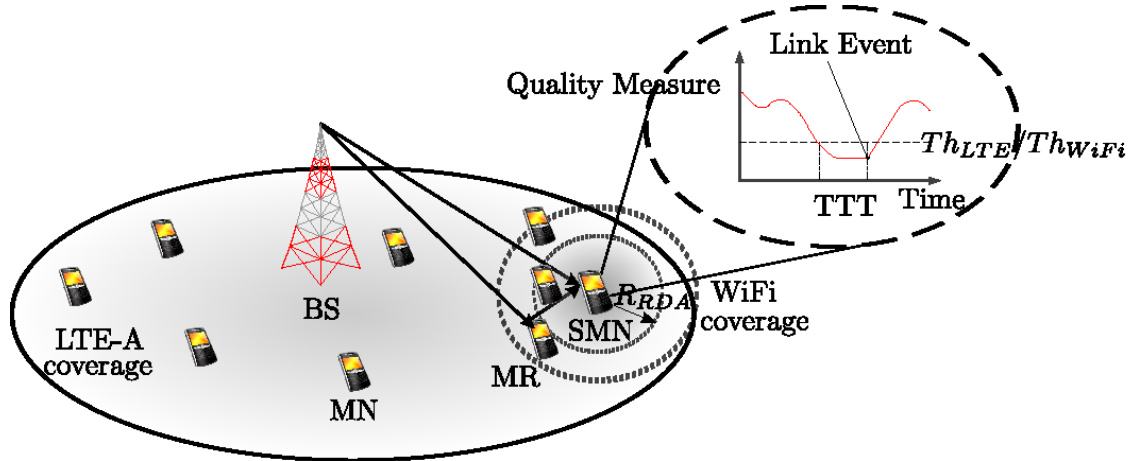

Fig. 2 Scenario under study

The MIH-Driven Relay Selection Mechanism (MIDRES) proposed uses MIH signaling to define a routing and handover mechanism for mobile relaying in Fourth Generation (4G) Mobile systems. In the considered scenario, it is assumed that nodes can have both LTE-A and WiFi radio interfaces simultaneously active. When handover occurs, the packet route switches from one technology to another and the old technology transits to the idle state. As shown in Fig. 2, if a MN connected to LTE-A experiences a SINR level below the quality threshold, Th_{LTE} , during Time to Trigger (TTT) seconds, then a Link Going Down (LGD) event is sent from lower layers to the MIH-User situated in upper layers. Similarly, a LGD event could be initiated and sent to the MIH-User in the MR. These events initiate the handover procedure.

It is assumed that all MNs and the BS are MIH-Users and implement MIHFs. In the BS the MIHF is also known as Point of Service (PoS). As shown in Fig. 1; **Error! No se encuentra el origen de la referencia.**, MIH communication among entities such as BS or MNs is carried out through MIHFs. The destination of an event is established with a subscription mechanism that enables MIH-Users to subscribe to particular event types located either in the same equipment or in remote nodes. The main difference between the

MIHFs of BSs and MNs is that MNs announce events from lower layers to the subscribed entities whereas the BS initiates and manages possible handovers among technologies.

In mobile relaying three different situations may occur:

1. **Situation 1.** The SMN is connected to LTE-A and the SINR level is lower than Th_{LTE} . In this case, MIDRES initiates the handover procedure to select the most appropriate MR.
2. **Situation 2.** The mobile relaying for a MN is active and either the LTE-A or the WiFi interface goes below the quality threshold. Then, MIDRES initiates the procedure looking for a new available MR or making a handover back to LTE-A.
3. **Situation 3.** The mobile relaying for a MN is active and the LTE-A SINR level of the MN is higher than the quality threshold¹. In this case, MIDRES initiates the procedure searching for the best connection configuration.

III.1. Situation 1

Fig. 3 shows the exchange of messages when mobile relaying provides better throughput to the SMN than the direct LTE-A link. The figure also shows the connection state for LTE-A and WiFi. In this situation, MIDRES procedure includes the following phases.

1. **Monitoring and Notification.** When the SMN detects that the SINR level is below Th_{LTE} during TTT seconds, the lower layers send a LGD event to the MIH-User that forwards this event to the BS with the Link_Parameters_Report.indication message.
2. **Information Query.** The BS MIH-User sends a Get_Information.request message towards the Information Server (IS) asking which relay nodes are candidates for relaying. The BS could attach a radius called R_{RDA} , centered at the indicated location. Otherwise, the IS would decide upon this radius. At this point, the IS can run the proposed Relay Discrimination Algorithm (RDA) to reduce MIH signaling. Basically, the RDA consists in selecting those cooperative MNs that are at a distance less than R_{RDA} from the SMN. Note that the IS can periodically estimate the location of all MNs using E-SMLC described in Section II.4. Finally the IS entity responds with a Get_Information.response message that includes the list of candidate MRs.
3. **Resource Availability Check.** After the confirmation of available relays, the BS sends a MIH_Net_HO_Candidate_Query.request to the MN providing the list of

¹ It is considered that the threshold is again Th_{LTE}

candidate MRs. The MN indicates the required resources in the MIH_Net_HO_Candidate_Query.response message.

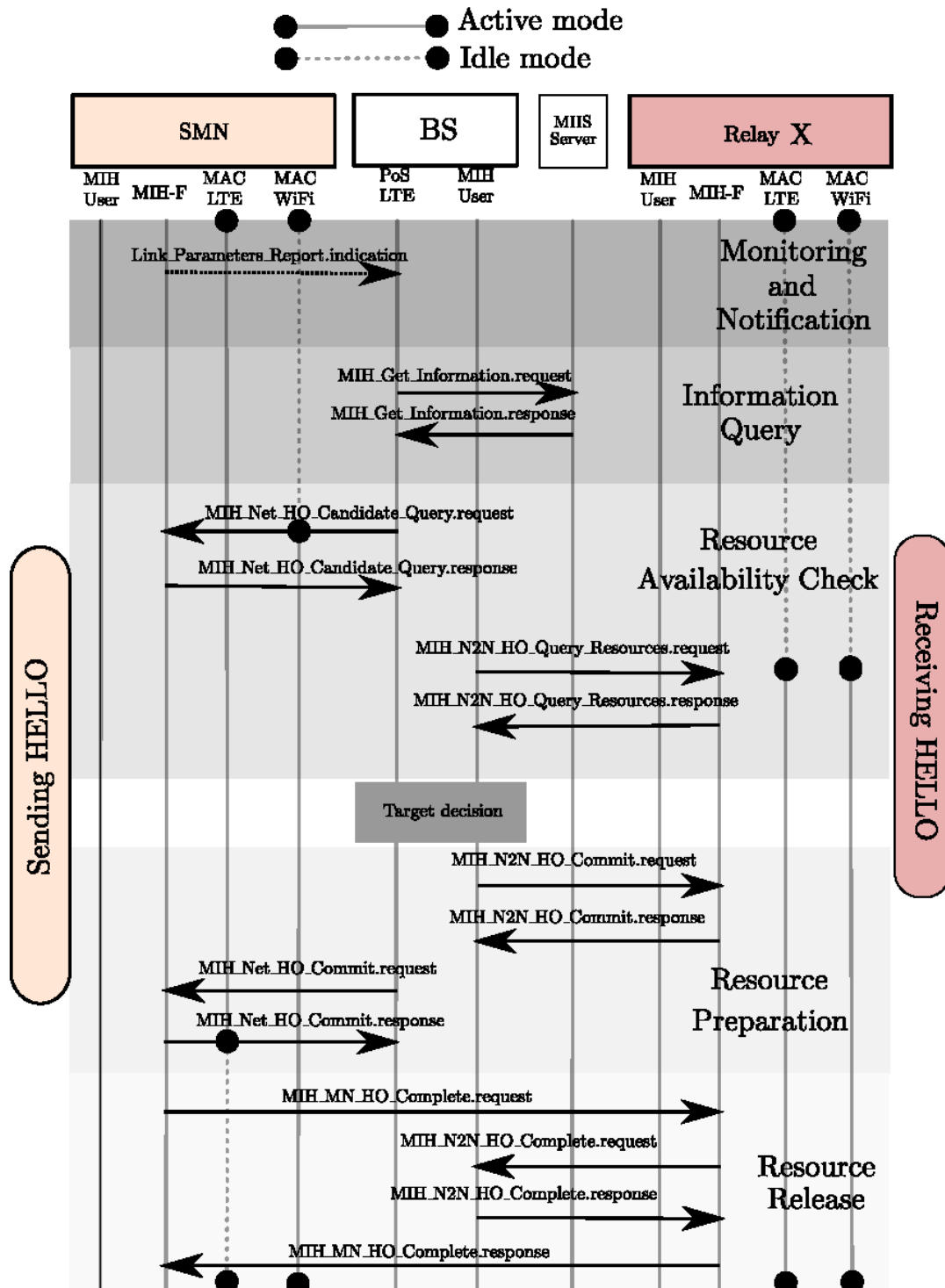

Fig. 3 MIDRES Procedure to configure a MR

At this stage the SMN activates its WiFi interface and sends periodic HELLO messages so that the candidates MRs can detect its presence. Next, the BS polls all

MR candidates on the feasibility of the connection by sending a MIH_N2N_HO_Query_Resources.request. Once the candidates receive this message, they activate their WiFi interface and measure the link quality that they are experiencing with the SMN, analyzing the received HELLO messages power and therefore the link throughput. After this measure, each relay node sends the result to the BS in a MIH_N2N_HO_Query_Resources.response message through the LTE-A interface. Note that, in addition to this information, the BS can estimate the mean throughput of its link with the MR since the LTE-A connection is active at this stage. Using these data, the BS decides on the best connectivity option that is, remain connected to LTE-A or use a MR.

4. **Resource Preparation.** If the best option is to use a relay then the process continues. The BS sends a MIH_N2N_HO_Commit.request message to the selected MR marking the beginning of the routing process. The relays answer with MIH_N2N_HO_Commit.response. From this point on, the relay will route all packets from BS to the SMN. For all purposes, the relay will be connected with the BS as another user. To distinguish the final destination (it may be that the relay receives packets for itself), the relay will only have to inspect the IP packet's destination address. Of course, for this to be viable, it is necessary that the relay possesses routing capabilities. In the same way, the BS informs the SMN about the decision with a MIH_Net_HO_Commit.request message to proceed with handover towards the specified relay. The new radio interface connection is established and the MN sends a MIH_Net_HO_Commit.response to the BS.
5. **Resource Release.** In the last stage mobile relaying must be confirmed. The SMN sends a MIH_MN_HO_Complete.request to the selected relay that answers with a MIH_MN_HO_Complete.response. The completion is also reported to the BS with a MIH_N2N_HO_Complete.request and its corresponding response message.

At this point it is worth discussing about another alternative of MIDRES in which the SMN measures the quality of the candidate MRs. Note that the decision of making the MRs measure the channel is aimed at reducing the handover delay. With the current proposal of MIDRES, the SMN is the only one sending HELLO messages and this reduces the contention problems. With the other alternative, all relay nodes should content to seize the channel and therefore there would be potential collisions and hidden node problems. As a consequence the time required for the handover will be much higher.

III.2. Situation 2

Fig. 4 shows the exchange of messages when, in an active mobile relaying, the power level of the WiFi radio interface falls below the threshold², Th_{WiFi} . When this happens, the MR sends to the BS the corresponding Link_Parameters_Report.indication message. From this moment all phases of the MIDRES procedure are identical to the Situation 1, except the resource release phase.

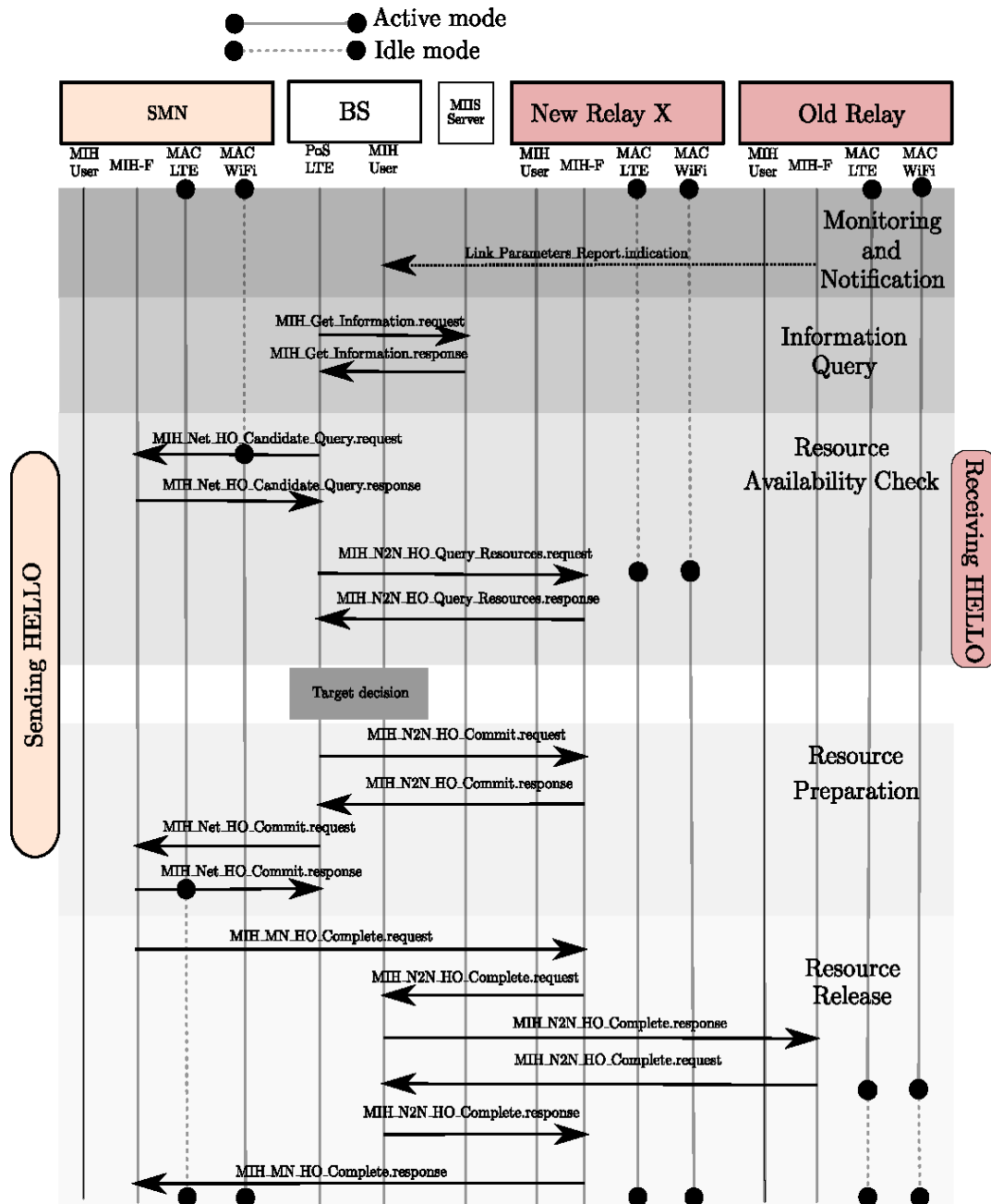

Fig. 4 MIDRES procedure to change MR

² Note that the procedure would be the same in case of degradation of the LTE-A link

Now the BS sends a MIH_N2N_HO_Complete.request to the old relay to release the assigned resources. The old relay answers with a MIH_N2N_HO_Complete.response message. Note that the procedure also contemplates the possibility of the direct LTE-A link being the most convenient one. In this case, the MN sends the MIH_MN_HO_Complete.request message directly to the BS.

III.3 Situation 3

When the LTE-A SINR level at the SMN is higher than the quality threshold, an event is sent from its lower layers to the MIH-User. This Link-Up event is notified by the SMN to the BS through a Link_Parameters_Report.indication.message. The signaling procedure is the same as in situation 2 with the possibility of not selecting any new MR.

IV. Assessment Methodology and System Modeling

Assessment methodology in this work was based on system level simulations. The baseline for the simulation methodology are the guidelines provided by [17] for the evaluation of International Mobile Telecommunications Advanced (IMT-Advanced) technologies. Nevertheless, some simplifications have been considered in order to reduce the complexity of the methodology proposed in [17].

A simple network layout was assumed with an isolated cell with a unique BS in its center that serves a circular area with radius R . A population of MNs is spatially uniformly distributed within the cell area. The initial position of a user u is randomly taken in polar coordinates from two uniform distributions, being the radius, $r_u = \sqrt{U[0, R^2]}$ and the angle $\alpha_u = U[0, 2 \cdot \pi]$.

Although in this model the cell layout deviates from the original one specified in [17], the same SINR Cumulative Density Function (CDF) as in the original layout is found in the cell of the new layout. This is achieved thanks to a position-SINR relation model specifically designed for this purpose. Using a complete simulator, with the original layout, the received SINR CDFs after antenna receiver were obtained for the different evaluation scenarios: Indoor hotspot (InH), Urban microcell (UMi), Urban macrocell (UMa) and Rural macrocell (RMa). Then for each user, position has a one-to-one correspondence with the SINR value according to the following formula:

$$SINR_u = CDF^{-1} \left(1 - \left(\frac{r_u}{R} \right)^2 \right) \quad (1)$$

where CDF is the SINR CDF for any particular scenario, and CDF^{-1} is the inverse. It is worth noting that in this model the higher SINR values are obtained for the lower distances between the BS and the MNs.

Multipath fading is not emulated in this assessment. Then, SINR values represent wideband measures. In LTE-A, channel capacity was obtained for each user translating the wideband SINR value to a throughput value through Look-Up Table (LUT) calculated in link level simulations. Different LUT were obtained for each evaluation scenario and MN multi-antenna configuration. Similar throughput vs wideband SINR curves are found in [2]. Both, the complete system level simulator and the link level simulator were validated in the framework of the Wireless World Initiative New Radio + (WINNER+) project [18] being used in the IMT-Advanced candidate evaluation carried out within ITU-R. Concerning WiFi, channel capacity is a function of distance between transmitter and receiver as described in [19]. In chapter V validation and system level simulators are widely explained to clarify this point.

MNs are in constant motion throughout the simulations with a fixed speed and follow a model similar to the Random Waypoint Model [20]. The MN path comprises a sequence of movement intervals in which direction is fixed. In each movement interval the starting point is the ending point of the previous interval, while the ending point is drawn from a spatially uniform distribution over the cell area.

MNs can be in two states and do not change their state during the simulation. MNs in idle state can relay signals while MNs in active state are receiving data and cannot relay signals. Concerning the traffic model, for the sake of simplicity a Constant Bit Rate (CBR) traffic source has been used. With respect to scheduling, LTE-A performs a proportional fair allocation of resources.

Scenarios/Speed (km/h)/Radius (m)	InH/3/20, UMi/3/67, Uma/30/167, RMa/120/577
Number of Active Nodes	10
Number of Idle Nodes	50
Packet Size (bytes)	128
Application Rate (Mbps)	4 (InH) / 2 (Umi, UMa and RMa)
TTT (ms)	100
WiFi Carrier frequency (GHz)	2.4
Wifi Bandwidth (MHz)	20
WiFi Transmission Power (dBm)	15
WiFi Antenna Configuration	1x1
LTE-A Antenna Configuration	1x2
LTE-A Bandwidth (MHz)	10

Table 1. Basic parameters used in the performance assessment

Finally, concerning MIH signaling, it is worth noting that the simulation tool models the MIH messages and accounts for the overhead that this additional signaling entails. Only the MIH subscription messages that can be originated both locally and remotely have not been considered in the signaling burden. Concerning handover delay, the simulation takes into account the idle to connected mode latency in LTE-A and all the time required in the discovery and connection phase of the WiFi interface.

Additional assumptions of the simulation methodology are indicated in Table 1.

V. Simulation tools

In this section the simulation tools used to obtain the results that will be shown in section VII are described. The simulation tool consists of two independent simulators. First, the simulator SPHERE (Simulation Platform for Heterogeneous wireless systems), which simulates link and system level, and SNG (Sphere New Generation), which handles the simulation for upper layers.

V.1. SPHERE

SPHERE simulation tool [21] constitutes a system and link simulation platform developed by Mobile Communications Group of iTEAM for researching wireless networks. SPHERE is formed by several advanced system level simulators of radio access technologies as GPRS, EDGE, HSDPA, WLAN and LTE. This simulation tool is based on CNCL libraries that help to manage an event driven simulation. In

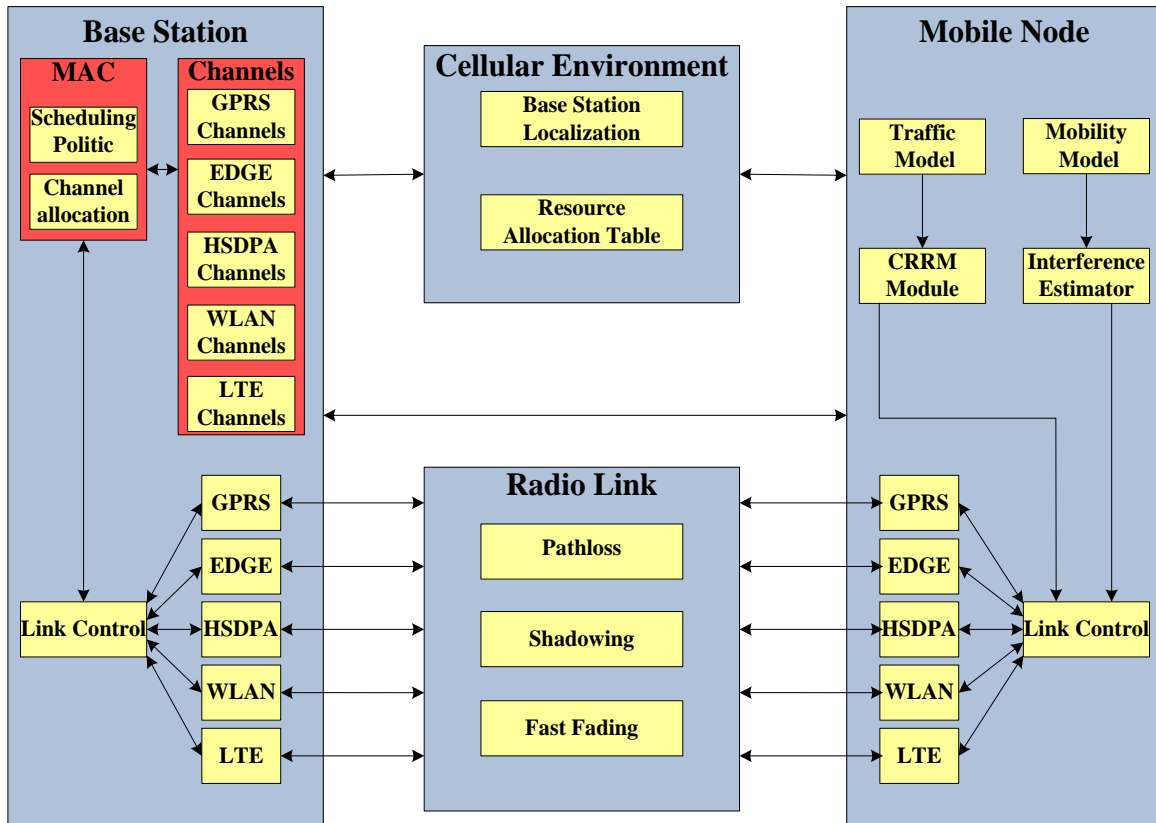

Fig. 5 it is shown SPHERE structure.

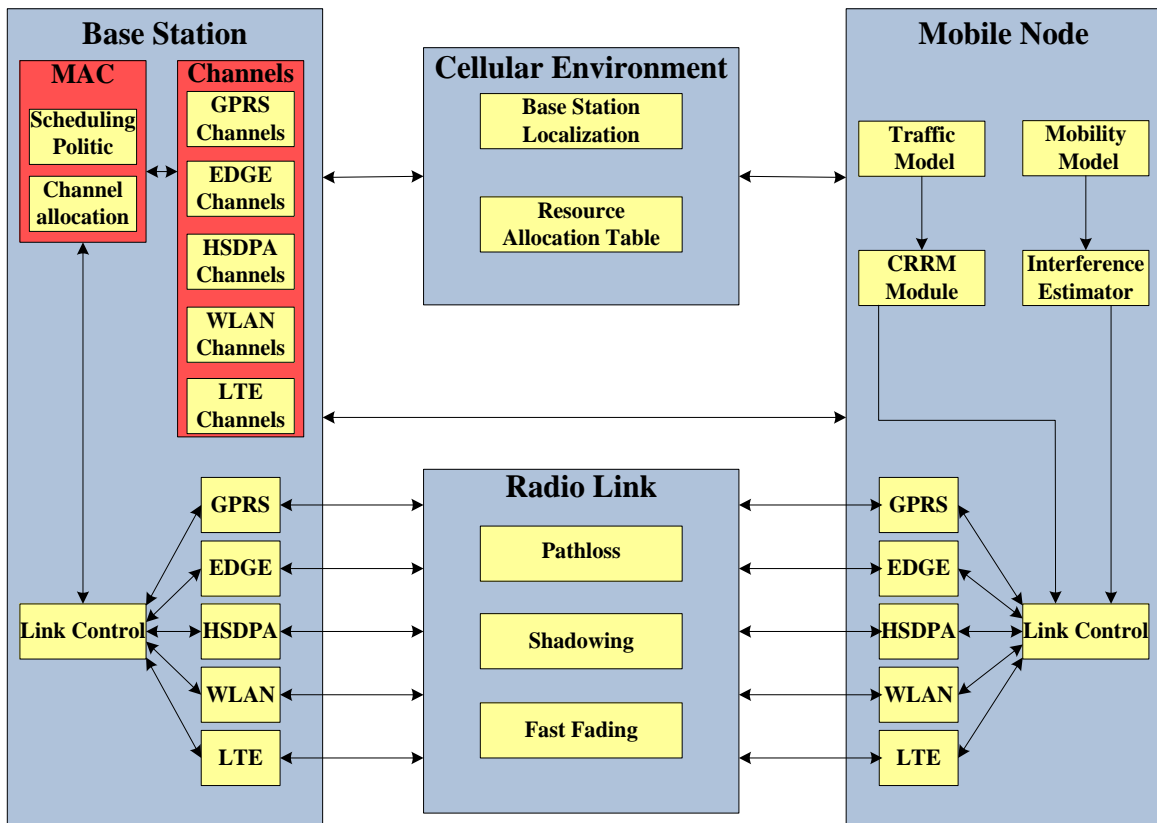

Fig. 5 SPHERE simulator structure

The aim of this master thesis is not to develop SPHERE and, therefore, we are not going to describe in more depth this tool. However, it is appropriate to remark that SPHERE has been validated with the results obtained by several companies belonging to the wireless communication sector as Nokia or Ericsson. Therefore, in order to validate the mobile relay simulation tool, SPHERE results are going to be the main reference.

V.2. SPHERE New Generation

The SPHERE New Generation simulator (SNG) has been developed with the purpose of simulating and testing new generation wireless networks, including elements considered and standardized for this type of networks. This master thesis aims at evaluating mobile relays behavior in fourth generation networks.

SNG implements the upper layers in the communication system. Therefore, when generated traffic arrives to the IP layer, SNG distributes packets to the different radio interfaces depending on the technology selected or the link considered. In this case, LTE link would be taken account when a BS-Relay connection is handled, being the WiFi interface the one used for the Relay-MN link.

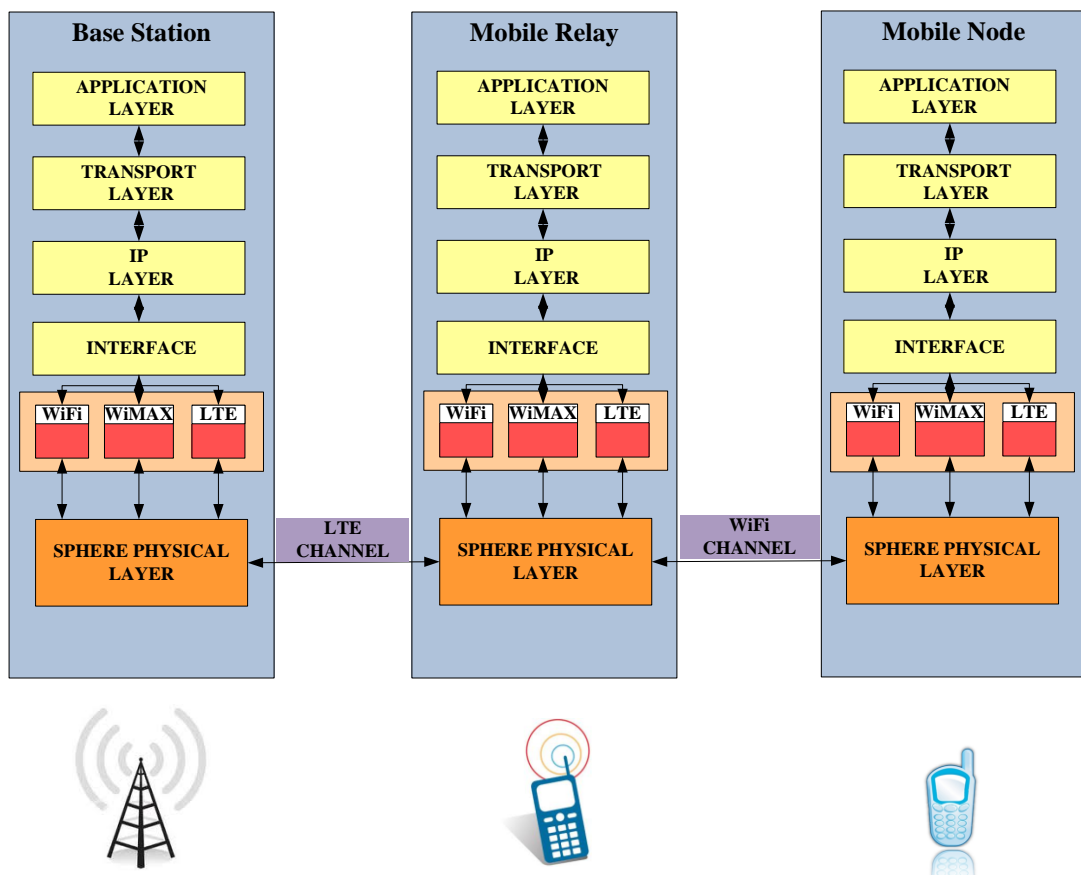

Fig. 6 SNG relay communication structure

V.3. Complete Simulation Tool

With a combination of the simulators specified in subsections V.1 and V.2 a fully capable simulation tool has been designed. In Fig. 6 it is shown the structure of this simulator where a relay link is established. Next subsections present the validation process of the simulator before showing the results of this master thesis.

It is important to note that when IP packets reach the interface layer, they are separated among three different packet buffers. These packet buffers only differ in the radio technology by which they will be sent. In this master thesis, only LTE and WiFi buffers are considered. Although all nodes implement the three buffers, BSs only use their LTE interface and MRs can use both LTE and WiFi depending on the link established.

Another significant aspect of the SNG simulation tool is the connection point with SPHERE. It happens just after the packet buffers. Depending on which technology is going to be used, the scheduler located in this interface layer will work in a different way. Depending on the technology, it also will route the packets through a different channel. The degradation and inherent problems of each channel are taken in account. As it can be seen, the physical layer and the aspects related to it, focus on SPHERE simulator.

V.4. Validation of Simulation tool

Aiming to validate the simulation tool, many tests have been applied to the simulator. In the next subsections these test are detailed.

V.4.1. Validation Scenario

SPHERE simulator does not include the capability of simulating mobile relays, so the validation procedure has been tested without the presence of mobile relays in the scenario. It is worth noting that it is not necessary the presence of relays for testing the link simulator. In Table 2 validation scenario conditions are listed.

Relays	No
Scenarios	InH, UMi, UMa and RMa
Number of Active nodes	50
Number of cells	1

Table 2 Validation scenario conditions

The main features of scenarios were extracted from [17] and are resumed in Table 3. These scenarios were proposed by ITU for testing and evaluating simulation tools. It allows getting uniform results to be compared with other researchers.

Scenario	Intersite Distance [m]	Users Velocity [km/h]
InH	60	3
UMi	200	3
UMa	500	30
RMa	1732	120

Table 3 ITU-R 2135 Validation Scenario Recommendations

V.4.2. Validation results

In the next figures, that is, Fig. 7, Fig. 8, Fig. 9 and Fig. 10, validation CDF curves have been plotted. It can be easily seen that curves do not converge. This is due to the different conditions of testing between SPHERE (curves named as iTEAM) and SNG+SPHERE (curves named as SNG) simulation conditions. The mobility pattern, number of cells, number of users and interference between cells differs from SPHERE curve conditions to SNG+SPHERE ones. Even with these light changes in the scenarios, the curves are very similar. The rapid end of the curve in SNG cases is mainly due to the fact that SNG considers other effects in the application rate.

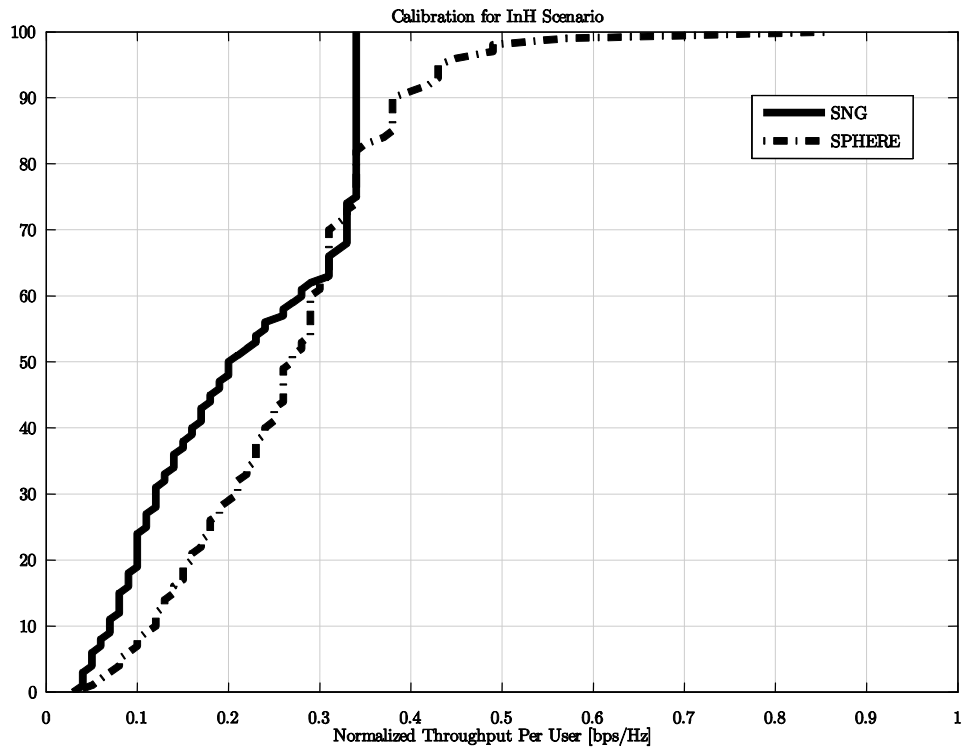

Fig. 7 CDF for InH scenario

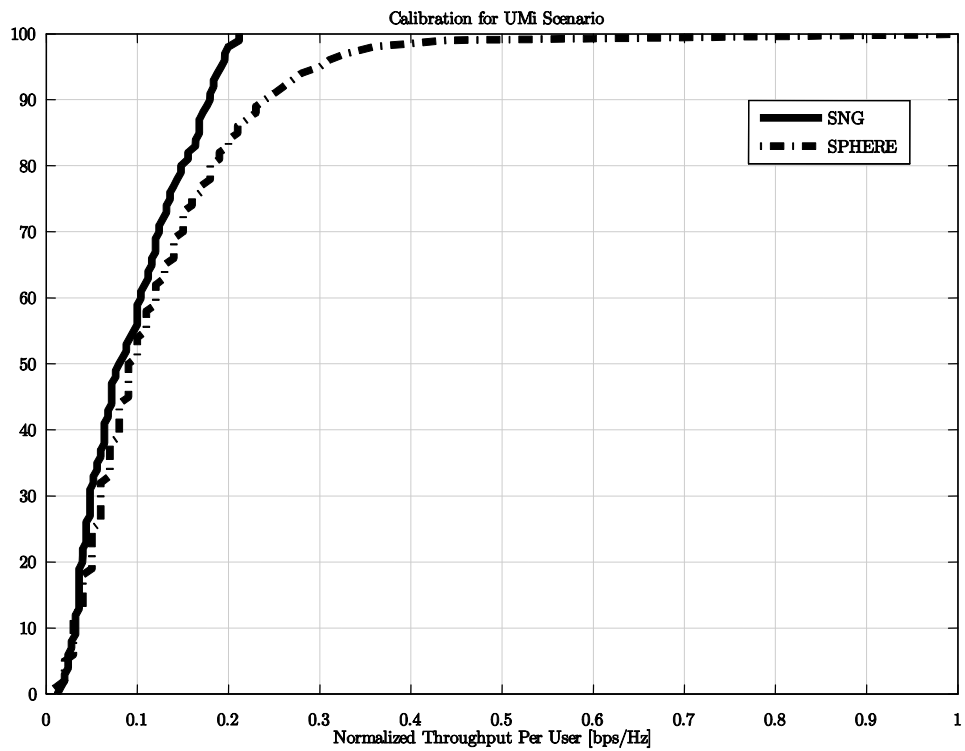

Fig. 8 CDF for UMi scenario

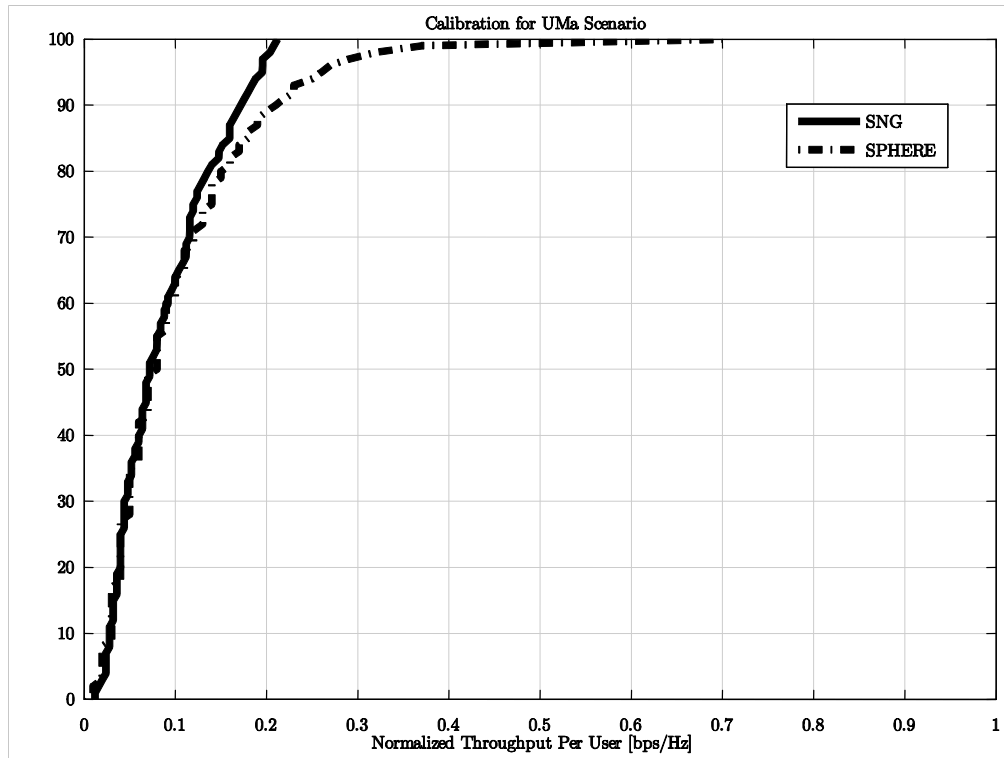

Fig. 9 CDF for UMa scenario

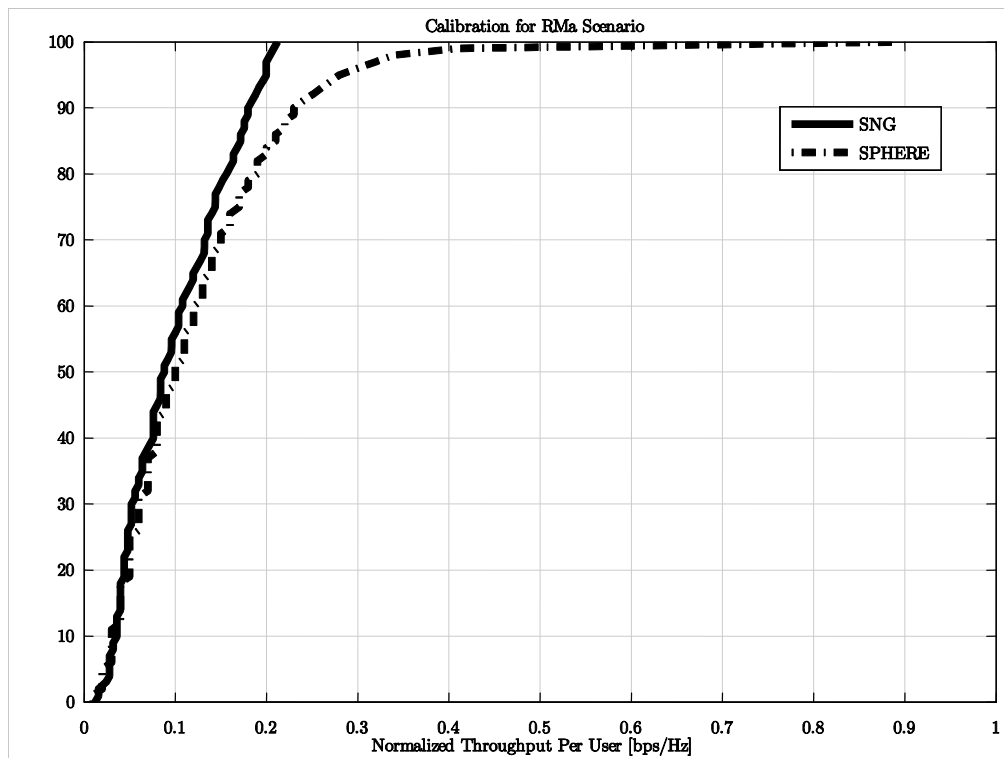

Fig. 10 CDF for RMa scenario

The obtained curves show the validity of SNG implementation. Another parameter usually taken in account to validate wireless communications simulators is the throughput within the cell-edge. In Table 4 these results can be seen.

Scenario	SNG cell-edge Throughput	SPHERE cell-edge Throughput
InH	0.06	0.08
UMi	0.03	0.03
UMa	0.02	0.02
RMa	0.02	0.02

Table 4 Cell-edge comparison for different validation scenarios

Again, calibration results can be considered highly satisfactory. The case of InH scenario is the only that differs a little bit from the reference results but this difference can be easily explained taking into account the the completely different user mobility management between simulation tools.

VI. Results and Discussion

MIDRES has been designed to make MIH protocol compatible with LTE-A system. With this aim, it is necessary to perform an optimal threshold setting to find a tradeoff between channel quality improvements and signaling overhead. Hence the importance of subsection VI.1. On the other hand, MIH signaling can cause a performance hit as the number of candidate relay node increases, since signaling overhead increases too. Subsection VI.2 presents some results concerning the RDA algorithm that reduces the amount of candidate relays and, consequently, the signaling overhead. Next, the effect of the MN speed on the performance of mobile relaying is evaluated in section VI.3. Finally, subsection VI.4 is devoted to the study of cost savings that result from using mobile relaying in LTE-A.

VI.1. Threshold evaluation

The study of the quality threshold set by the MIH-Users is of paramount importance to reach equilibrium between signaling load and performance. There exist three thresholds:

1. WiFi threshold (Th_{WiFi}): If the WiFi link falls below this threshold the MR replacement process starts.
2. LTE-A threshold (Th_{LTE}): This threshold activates the search of a MR to support the connectivity.
3. LTE-A reactivation threshold: If the LTE-A signal surpasses this threshold then the SMN could be back to the single-hop LTE-A communication.

For the sake of simplicity, Th_{WiFi} is set to -82 dBm and the reactivation threshold equals Th_{LTE} . Therefore, this section only focused on the optimization of the LTE-A threshold

based on, firstly, the minimization of the number of required relays and, secondly, the maximization of the Cell-edge User Throughput (CEUT).

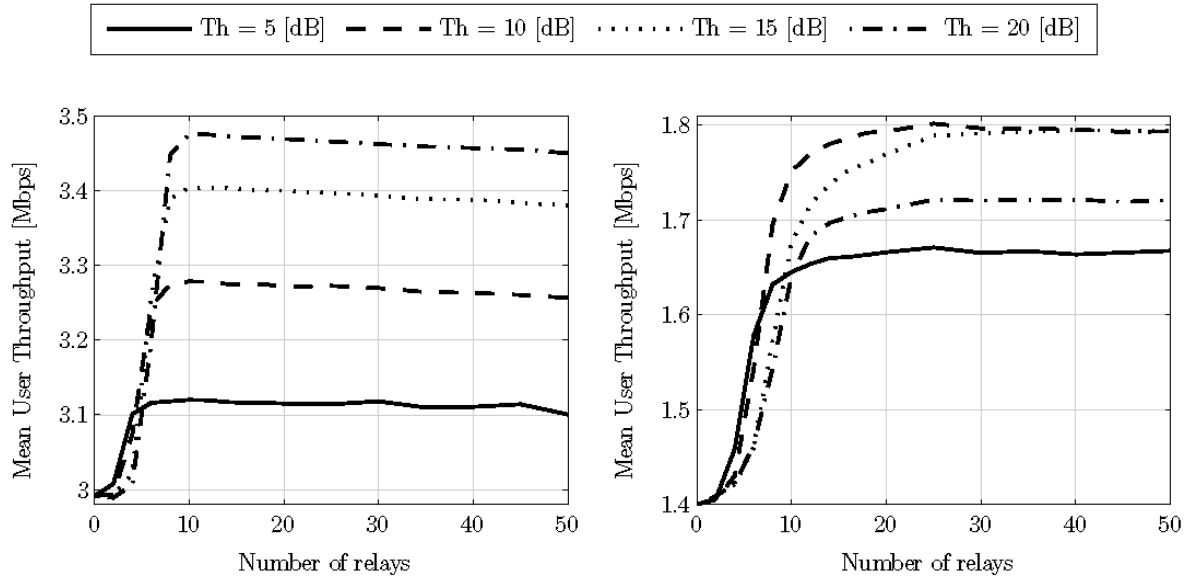

Fig. 11 Threshold analysis for InH (left) and UMi (right) scenarios

Fig. 11 evaluates the Mean User Throughput (MUT) with an increasing number of MR available in the scenario³. Two scenarios (InH and UMi) and four thresholds are depicted. The number of active nodes in the cell is 10 following the guidelines provided by [17].

It can be observed that mobile relaying improves remarkably system performance. In the InH scenario, the higher the threshold is the better the performance. It is always beneficial to use a MR since, in such small scenario, the WiFi interface exhibits higher data rates and reducing the hop length in LTE-A also improves performance. However, there is an optimum in the number of MRs, which in the InH case is around 10. With more than 10 MRs the additional diversity in the selection of the best MR does not compensate the increase in signaling. To sum up, for small scenarios the LTE-A threshold must be set as high as possible but the candidate set must be restricted to 10.

Th_{LTE} [dB]	10	11	12	13	14	15
CEUT [Mbps]	1.5797	1.5916	1.5630	1.5524	1.4598	1.4377

Table 5 CEUT for different Th_{LTE}

However, for wider scenarios the selection is more challenging. As an example, it is analyzed the UMi case. If Th_{LTE} is too small, the system does not benefit from the

³ Note that 0 MR represents the scenario without mobile relaying

availability of relays. In fact, with a small number of available relays it is better to choose a lower threshold since with higher probability the relay will not be beneficial for the link. On the contrary, if Th_{LTE} is too high, with higher probability the WiFi link would be worse than the LTE-A link and the system would waste resources on useless signaling. Therefore, an in-depth analysis is needed.

Fig. 11 shows that the minimum number of relays to get good diversity is around 20. Note that this number is higher than in the InH case, since more relays are required to have the same diversity in the selection of the best MR. On the other hand, Fig. 12 shows the MUT CDF for this required minimum number of MRs. In the UMi scenario the optimum threshold changes depending on the objective. In order to maximize the CEUT (5th percentile of the CDF), the best threshold is between 10 and 15 dB. In fact, the optimum is surround 11 dB as shown in Table 5.

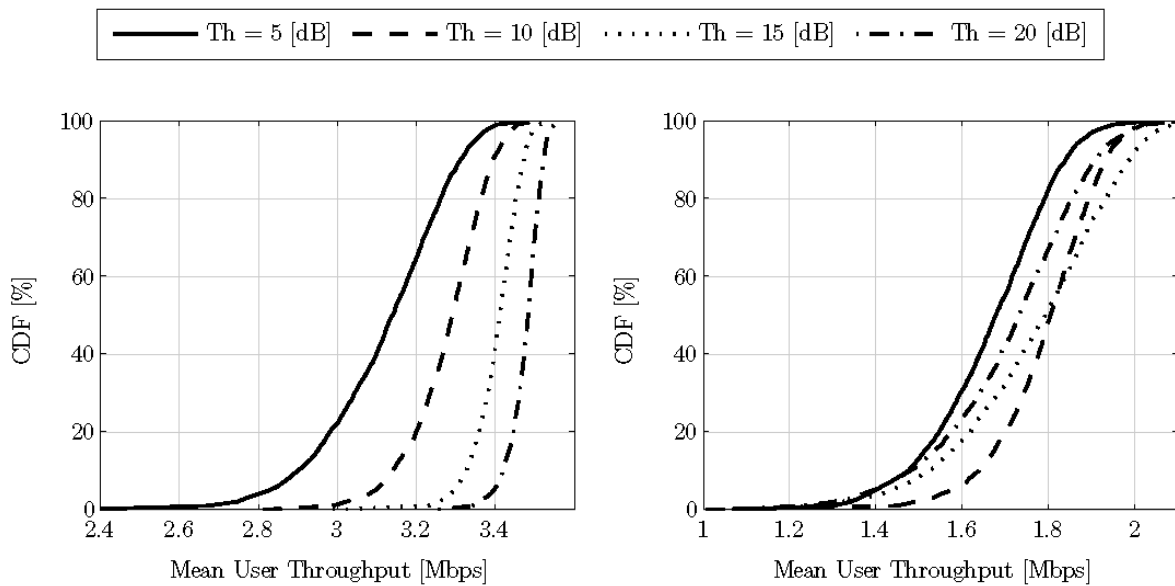

Fig. 12 CDF of the mean user throughput for InH (left) and UMi (right) scenarios

For the UMa and RMa scenarios, the same conditions have been simulated. In Fig. 13 the throughput curves are displayed showing that for the UMa case the required minimum number of MRs is around 25. Concerning the RMA scenario, the best performance with mobile relays is accomplished for nearby 40 MRs. Again, the optimum thresholds were derived for both scenarios.

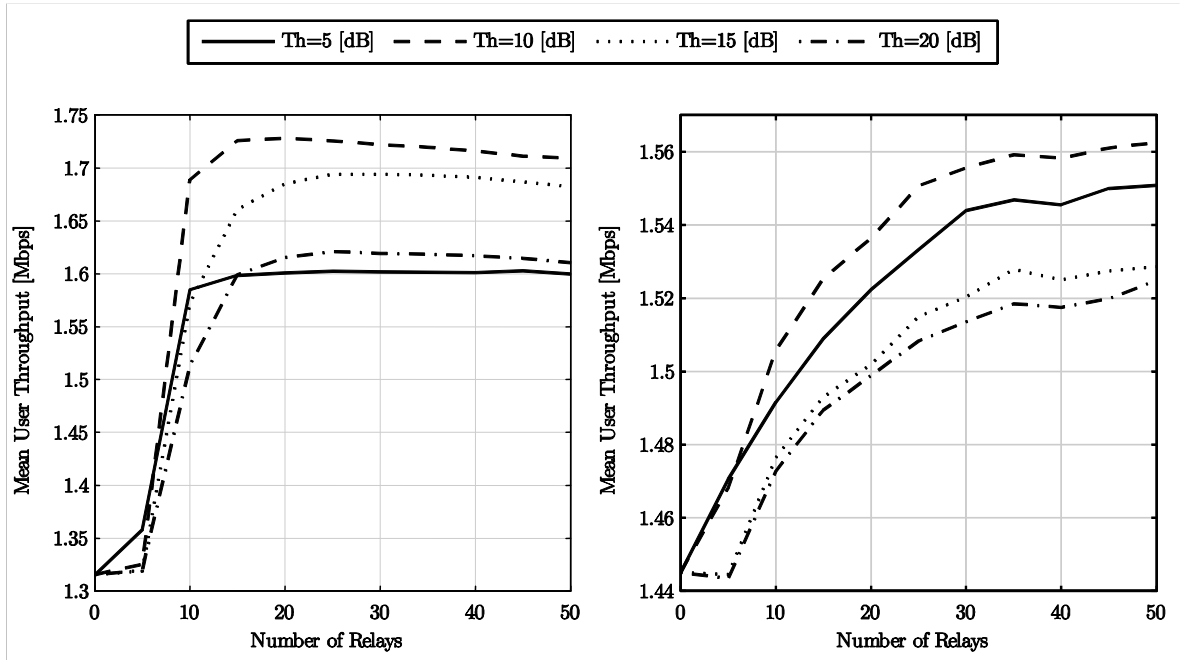

Fig. 13 Threshold analysis for UMa (left) and RMa (right) scenarios

VI.2. Performance evaluation of the Relay Discrimination Algorithm (RDA)

The Relay Discrimination Algorithm (RDA) is useful for reducing the MIH signaling. Without the use of this algorithm by the MIIS server, the BS would send a MIH_N2N_HO_Query_Resources.request to all idle nodes. As the number of cooperative nodes increases the MIH protocol could be unfeasible. Thus, RDA algorithm only requires that the MIIS Server knows the MNs location. As discussed in section 2.4, LTE-A standard encompasses several positioning methods that can be used for this purpose.

In this subsection the UMa scenario is assumed with $Th_{LTE}=12$ dB. Fig. 14 shows the MUT varying the parameter R_{RDA} for an increasing number of MRs. It can be seen that, when restricting the search area, a larger number of cooperative relay nodes is required to get the same MUT since the probability of a relay being in the search area is smaller. However, when the number of available relays increases, there is an increment in the signaling load that can be reduced with the RDA. In fact, the optimum value for R_{RDA} depends on the number of available MRs as shown in Fig. 14. For a higher number of cooperative nodes a smaller search radius must be used, since this reduces the signaling overhead.

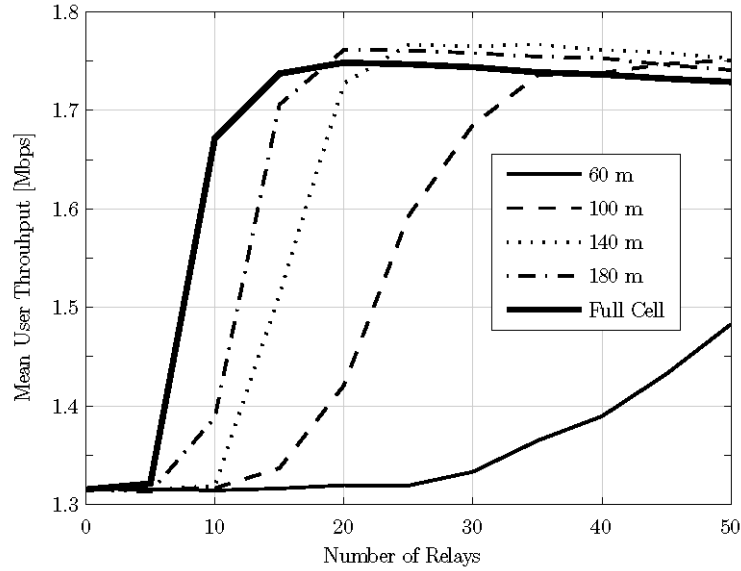

Fig. 14 Mean user throughput for different R_{RDA} values in a UMa scenario

VI.3. Velocity impact evaluation in performance

This subsection evaluates the effect of MN speed on the mobile relaying performance. The UMa scenario was simulated, in which user speed augmented from 40 to 90 km/h. Fig. 15 shows that the performance of mobile relaying deteriorates as the user speed increases. This is due to the fact that the mobile relaying links are less stable and signaling and handover delay degrade the MUT. However, even with 90 km/h mobile relaying is preferred as compared with the conventional single-hop scenario. This is due to the fast-switching capacity of MIDRES and the good coverage of WiFi in outdoor.

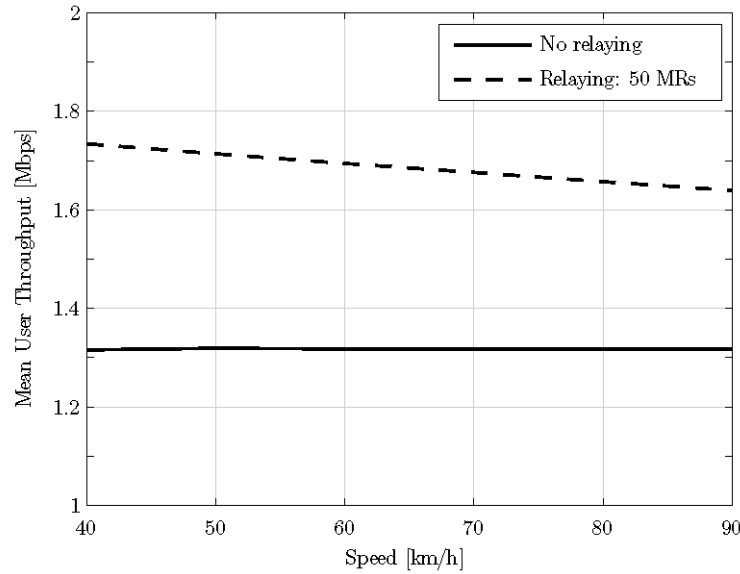

Fig. 15 Mean user throughput for different values of MN speed in the UMa scenario

VI.4. Deployment cost in a LTE-A system

LTE-A systems are designed to increase end user data rates as compared with Third Generation (3G) systems. These high data rates may only be offered to users near the BS, creating a situation of unfairness between MNs. However operators aim to offer higher rates to as many users as possible with the least possible cost. The use of MRs is considered as a key factor to increase the coverage thus deploying a lightweight wireless system.

A simplified high level financial analysis if the LTE-A deployment was performed to assess the reduction of costs that can be achieved through the use of MRs. This study was carried out for a fictive region of an area of 200 km² similar to that described in [22], which represents a typical European city scenario. Although the total population was assumed to be 500000 people, the LTE-A network was expected to cover only 70% of the population. In particular, according to [22], the number of LTE-A subscribers served by one operator in this fictitious scenario was predicted to be, at most, 55000 by the third year. That is to say a population density of 275 people per km² is considered.

In order to study the real economical impact of mobile relaying, a quality criterion for Cell-Edge User Spectral Efficiency (CEUSE) of 0.12 b/s/Hz was fixed. Multiple simulations were performed to assess the number of base stations required to achieve such quality criterion in a scenario with the above-mentioned population density. The number of active MNs in each cell was 1/3 of this total number, being the rest of users in idle state.

The number of possible MRs in each cell is a percentage of the number of idle users. The considered percentages range from 0% (network without relaying) to the 100% in steps of 20%. In all simulations $Th_{LTE} = 12$ dB.

As shown in Fig. 16, a network without relaying reaches the quality criterion with a cell radius of 192.35 m, whereas with a percentage of 80% among idle nodes, coverage increases by 7.46 m, which represents an increase of 7.91%. With 100% of relay nodes coverage increases 19.35 m, that is, a 21.16%. Note that without using relaying until a percentage of 60% of idle nodes, the CEUSE is almost equal for different cell radius.

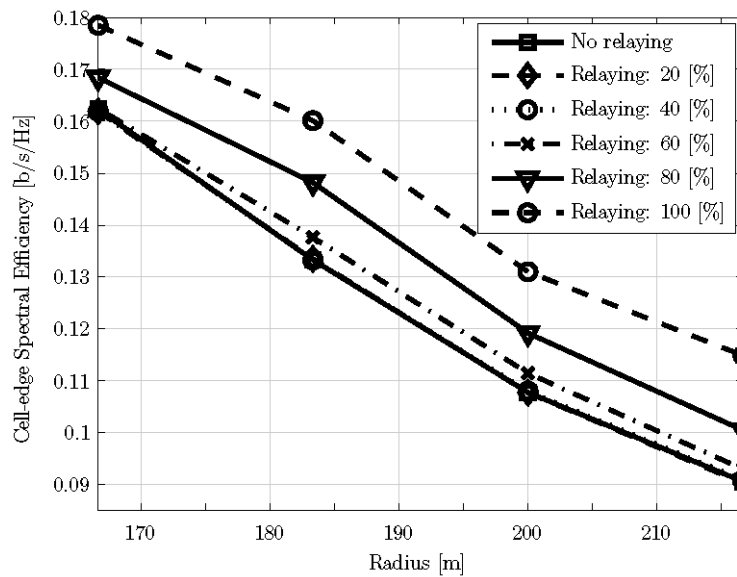

Fig. 16 Cell-edge user throughput versus cell radius with different percentages of cooperative nodes

For the financial analysis, Capital Expenditure (CAPEX) and Operational Expenditure (OPEX) per year were calculated. In the CAPEX analysis it was assumed that the mobile operator deploys LTE-A using the available infrastructure. Therefore, civil work expenditures were not taken into account, neither the cost of acquiring spectrum licenses, since operators may use frequency bands of current technologies to minimize the cost of LTE-A. Finally, CAPEX encompasses LTE-A equipment cost (50 k€ per site [23]), labor-related deployment cost (10 k€ per site) and upgrading the existing backhaul (2 k€ per site). The number of sites (composed of three cells in this study) multiplied by the investment cost per site yields the overall operator network investments. By combining the coverage area and the BS range, previously calculated, it is easy to obtain how many BSs are required.

On the other hand, OPEX accounts for site rental (10 k€ per site per year [24]), data backhaul costs (5k per site [24]), maintenance (3k€ per site [24]), marketing cost (1.85€ per person [23]), administrative costs (addition of 10% of running costs [23]) and the subsidy paid by the operator to reduce the price of new mobile terminals, this facilitating the migration of subscribers (160€ per subscriber [23]). Similarly, OPEX was calculated multiplying the number of sites by the running cost per site plus terminal subsidies, considering that the migration of subscribers to the new network occurs in progressive stages during these three years. Note that only one terminal replacement per user was supposed in this study. Moreover, OPEX is increased with the annuity payment of a loan for CAPEX requirements over this period at an interest rate of 4%.

Table 6 shows the resulting deployment costs. For instance, according to the simulations, CAPEX varies from around 43 M€ with a basic LTE-A system to around 36 M€ when mobile relaying is added. This represents a 17.47 % savings.

Scenario	CAPEX [M€]	OPEX [M€]
LTE-A	43.09	33.23
LTE-A (80%)	39.93	31.07
LTE-A (100%)	35.57	28.11

Table 6 Cost analysis of the LTE-A deployment

VII. Conclusions

LTE has been designed as a future technology to cope with upcoming user requirements. It has been proposed a new relay selection mechanism based on the use of MIH signaling. This allows including mobile relaying as an additional technique in an LTE-A system. The implementation of mobile relaying in LTE-A certainly enhances the overall system performance. In addition, the proposed relay selection procedure is a low-cost solution because no modifications of the LTE-A system architecture are required for its implementation.

However, the MIH-Driven Relay Selection Mechanism must be set up carefully and several aspects have been discussed throughout this master thesis. First, SINR threshold that triggers the selection of relay must coincide with the point in which cellular system is unable to cover user quality of service. Moreover, the selection of the relay entails additional signaling that must be reduced to a minimum to make the most of mobile

relaying. A simple technique has been shown in this document to highlight the importance of this signaling overhead.

Finally, it has been shown the relevance of mobile relaying to reduce deployment costs. In a typical European city scenario, the reduction of CAPEX and OPEX is about 17.47 % and 15.39 %, respectively.

VIII. Future Work

Despite the good results achieved during the evaluation of 802.11n mobile relays complementing a LTE-A deployment, the WiFi technology has some disadvantages that have been reflected in the proposed system. These restrictions of 802.11 technologies would be minimized by the use of LTE-A based mobile relays. Using these type of mobile relays would bring, in addition to the benefits of the LTE-A technology in terms of throughput and Quality of Service (QoS), benefits in power consumption. This is due to the fact that only one radio interface would be needed. This LTE-A radio interface must handle and schedule its own resources (non transparent mobile relays) or the enodeB to which it is associated must do the scheduling process (transparent mobile relays).

The research community is working in this line and research in LTE-A mobile relaying is expected to experience a big growth throughout next years.

IX. References

- [1] ITU World Telecommunication/ICT Indicators database, *Global ICT developments, 2000-2010*. ITU Statistics (<http://www.itu.int/ict/statistics>), 2010.
- [2] Martín-Sacristán D., Monserrat J.F., Cabrejas J., Calabuig D., Garrigas S. and Cardona N., *On the way towards Fourth-Generation Mobile: 3GPP LTE and LTE-Advanced*. EURASIP Journal on Wireless Communications and Networking, vol. 2009 10 pages, 2009.
- [3] IEEE 802.16j, *IEEE Standard for Local and metropolitan area networks Part 16: Air Interface for Broadband Wireless Access Systems, Amendment 1: Multi-hop Relay Specification*, 2009.
- [4] 3GPP TR 36.913 V10.0.0, *Requirements for further advancements for Evolved Universal Terrestrial Radio Access (E-UTRA) (LTE-Advanced) (Release 10)*. Technical Specification Group Radio Access Network, 2011.
- [5] Xiao L., Fuja T. E. and Costello D. J., *Mobile Relaying: Coverage Extension and Throughput Enhancement*. IEEE Transactions on Communications, 2010.
- [6] Vanganuru K., Puzio M., Sternberg G., Shah K. and Kaur S., *Uplink System Capacity of a Cellular Network with Cooperative Mobile Relay*. Wireless Telecommunications Symposium, 2011.
- [7] Li Z. and Shen H., *Game Theoretic Analysis of Cooperation Incentive Strategies in Mobile Ad-hoc Networks*. IEEE Transactions on Mobile Computing, 2011.
- [8] IEEE 802.21, *Draft Standard for Local and Metropolitan Area Networks: Media Independent Handover Services*. IEEE P802.21, D9.0, 2008.
- [9] Bae S. J., Chung M. Y. and So J., *Handover Triggering Mechanism Based on IEEE 802.21 in Heterogeneous Networks with LTE and WLAN*. Information Networking (ICOIN), 2011.
- [10] Seol K. and Chung J., *IEEE 802.21 MIH based Handover for Next Generation Mobile Communication Systems*. Innovations in Information Technology, 2007.
- [11] ITU-R M.2133, *Requirements, evaluation criteria and submission templates for the development of IMT-Advanced*. REPORT ITU-R, 2008.
- [12] 3GPP TR 36.806 V9.0.0, *Relay architectures for E-UTRA (LTE-Advanced) (Release 9)*. Technical Specification Group Radio Access Network, 2010.
- [13] IEEE 802.11n, *Part 11: Wireless LAN Medium Access Control (MAC) and Physical Layer (PHY) Specifications. Amendment 5: Enhancements for Higher Throughput*, 2009.
- [14] 3GPP TS 36.305, *Stage 2 functional specification of User Equipment (UE) positioning in E-UTRAN*. Technical Specification Group Radio Access Network, 2011.
- [15] 3GPP TS 36.355, *LTE Positioning Protocol (LPP)*. Technical Specification Group Radio Access Network, 2011.
- [16] 3GPP TS 36.455, *LTE Positioning Protocol A (LPPa)*. Technical Specification Group Radio Access Network, 2011.
- [17] ITU-R M.2135, *Guidelines for evaluation of radio interface technologies for IMT-Advanced*. REPORT ITU-R, 2009.

- [18] WINNER+ Evaluation Group,
<http://projects.celtic-initiative.org/winner+/WINNER+%20Evaluation%20Grup.html>.
- [19] Green D.B and Obaidat A.S, *An accurate line of sight propagation performance model for ad-hoc 802.11 wireless LAN (WLAN) devices*. Communications, 2002.
- [20] Johnson D. B. and Malts D. A., *Dynamic source routing in ad hoc wireless networks in Mobile Computing*, edited by Torrasz Imielinski and Hank Korth, chapter 5, pages 153-181, Kluwer Academic Publishers, 1996.
- [21] M.López, J.Gozálvez, M.C.Lucas Estañ, *Sphere-Plataforma Avanzada de Simulación para Sistemas Inalámbricos Heterogéneos*, XXI Simposiúm Nacional de la Unión Científica Internacional de Radio, 2006.
- [22] WiMAX Forum. *A Comparative Analysis of Spectrum Alternatives for WiMAX Networks with Deployment Scenarios Based on the U.S. 700 MHz Band*. WiMAX Forum Website, 2008.
- [23] Forge S., Blackman C. and Bohlin E., *The demand for future mobile communications markets and services in Europe*, IPTS Technical Report Prepared for the European Commission – Joint Research Centre, 2005.
- [24] Johansson K., Furuskar A., Karlsson P. and Zander J., *Relation between base station characteristics and cost structure in cellular systems*. IEEE PIMRC-2004,2004.

Application of MIH for the Lightweight Deployment of LTE-Advanced Systems through Mobile Relaying

Jorge Cabrejas, Pablo Gualda, Jose F. Monserrat and David Martin-Sacristan

Abstract. In a conventional cellular network end users connect directly to a Base Station (BS). Mobile relaying allows establishing an indirect two-hop link between the end user, called Mobile Node (MN), and the BS through a Mobile Relay (MR). This spreads out the cell coverage and increases the cell-edge throughput hence improving fairness among nodes. This paper is focused on a Long Term Evolution Advanced (LTE-A) cellular network where MNs and MRs are connected through a Wireless Fidelity (WiFi) ad-hoc connection. It is proposed the use of Media Independent Handover (MIH) signaling to define an efficient dynamic routing mechanism for MR in this framework. The proposed mechanism, called MIH-Driven Relay Selection Mechanism (MIDRES), detects which is the best direct or indirect link with the BS based on information collected using MIH messages. The MNs or MRs send MIH messages when experiencing bad channel conditions, that is detected thanks to predefined thresholds. Then, the BS starts a polling process, again supported by MIH signaling, and performs optimal route selection either through the LTE-A radio interface or through a WiFi ad-hoc interface. This paper examines the implementation of this mechanism and obtains the optimal thresholds that maximize operational performance. Moreover, the potential benefit of this LTE-compliant mobile relaying solution is evaluated using a calibrated simulation tool. The results show significant savings in cost of network deployment.

Keywords. Mobile Relaying, MIH, LTE, LTE-Advanced.

1. Introduction

The volume of data traffic has increased significantly in recent years. In fact, in December 2009 for the first time in history, the volume of worldwide voice traffic was below data traffic [1]. Extrapolating this trend, it is estimated that by 2020 data traffic will be the dominant in mobile communications primarily due to the proliferation of applications like video streaming. As a solution to this demand, new technologies such as Long Term Evolution Advanced (LTE-A) [2] or Worldwide Interoperability for Microwave Access (WiMAX) IEEE 802.16m have emerged as promising standards. These technologies are designed to deliver peak data rates above 1 Gbps with bandwidths of up to 100 MHz for low mobility users and 100 Mbps for high speed users [3]. However, high data rates can only be provided within the vicinity of Base Station (BS). Therefore, it would take a large number of BSs to cover a given area with high data rates. Obviously, this implies a deployment cost that operators cannot afford. This situation motivated the study and development of relays as a mean to increase the coverage indoor scenarios and public transportation vehicles (trains, buses, etc).

The use of fixed cooperative relays has already been introduced in WiMAX Mobile [4] —Institute of Electrical and Electronic Engineers (IEEE) 802.16m standard— and in the Third Generation Partnership Project (3GPP) LTE-A standard. Although the results are valid for both systems, this paper is focused on the 3GPP solution.

A further step towards full integration of relaying is the use of mobile terminals as relays, which is known as mobile relaying. In [6] Xiao *et al.* studied the usage of Mobile Relays (MRs) to extend coverage and increase throughput. Results showed an increase in coverage ranging from 21% to 44% depending on the distance from the Mobile Node (MN) to the BS, and an increase in maximum throughput from 20% to 60% depending on the transmission power and the path loss exponent. In [7] Vanganuru *et al.* proposed the use of a hybrid wireless network with direct radio links between MNs. The BS chooses the best relay to maximize the throughput of each radio link. This mechanism results in average throughput gains of 40% assuming capacity is calculated with Shannon formula and regardless of the cost of signaling in the selection of the best relay.

Concerning the motivation of users to collaborate as MRs, there is a lot of literature addressing different ways to reinforce this cooperation (see e.g. [8]). Among other strategies, [8] presents the idea of reputation, in which users cooperate to increase their status and, consequently, be aided in the moments in which they need the support of another MR.

However, the optimal relay selection is of great importance and signaling overhead cannot be underestimated. An optimal routing mechanism must be defined so as it can dynamically adapt to changes in the system while involving the least possible signaling overhead. To date, the LTE-A standard only contemplates the use of fixed relays and lack any mechanism of MR selection.

Within this framework, this paper proposes the use of IEEE 802.21 Media Independent Handover (MIH) standard to support the relay selection process. MIH standard is an application protocol that can be easily implemented on mobile and network devices. MIH defines a set of entities and messages that facilitate the interchange of information between network nodes. It allows to have local and remote reports on link status so that decisions can be made dynamically in the access network. Besides, it provides intelligence to both the physical and Medium Access Control (MAC) layers and network information to upper layers [9]. Initially, this standard was designed to optimize handovers in heterogeneous networks. In [10] Bae *et al.* proposed to use MIH signaling to support a triggering mechanism for the management of vertical handovers based on the data rate. On the other hand, Seol and Chung proposed to conduct vertical handover between LTE and WiMAX by adding some new nodes in the core network with a MIH Function entity (MIHF) [11]. The work from Bultmann *et al.* [12] addressed handover signaling and introduced discovering capacity and some procedures for handover in heterogeneous networks assuming LTE assisted with fixed relays. It is worth noting that MIH signaling was only used to make handovers between BSs of different networks rather than to select relays.

This paper proposes a new application of MIH signaling to the management of multiple radio interfaces in a cellular system assisted with MRs. The system scenario comprises an LTE-A network where MNs have another WiFi radio interface for ad-hoc communications. This assumption is fully aligned with current technological trends since both radio interfaces are expected to coexist in coming mobile devices. This paper aims at analyzing the signaling requirements and provides not only an optimal configuration but also mechanisms for reducing the overhead. Moreover, we analyze to what extent mobile relaying can support the deployment of lightweight networks.

The rest of the paper is organized as follows. Section 2 shortly analyzes the enabling technologies necessary to implement the chosen solution. Section 3 describes the relay selection mechanism based on MIH signaling. Then, Section 4 presents the simulation methodology used to assess the performance of the new algorithms. Results are presented in Section 5. Finally, conclusions of the study are commented in Section 6.

2. Current Technological Scenario

In order to use MIH signaling to manage the routing of packets dynamically it is necessary to define a set of technological tools that support the proposed solution. The following sections define the basis of these technologies.

2.1. LTE-Advanced

4G cellular systems are being designed to increase the coverage and user data rates. The spectrum for 4G systems can be distinguished into five bands: the 450 MHz band, the Digital Dividend (DD) band around 700 MHz (spectrum available after the switchover from analogue to digital television), Advanced

Wireless Services (AWS) band between 1.7 - 2.1 GHz, the 2.5 GHz and, finally, the C band around 3.5 GHz [13]. As can be seen, most of these bands are above 2 GHz, where propagation loss exponent is higher and therefore, under these conditions, traditional cellular architectures require a higher density of BSs. Obviously, increasing the density of BSs is very costly for operators and other alternatives are preferred. One solution may be to increase the allocated bandwidth or spectral efficiency. Indeed, this paper will show that mobile relaying implies a significant increase in spectral efficiency.

In a relay scenario there are three types of link: a BS to user link, a base station to relay link (also known as backhaul) and a relay to user link. It is worth noting that the relay node is wirelessly connected to the radio access network through the BS or donor cell. 3GPP distinguishes two types of architectures [5] focusing on fixed relays:

- **Architecture A.** This architecture is based on the termination at the relay of both U-Plane and C-Plane protocols of the S1 interface. In this proposal, the relay can be seen as a BS for the user.
- **Architecture B.** In this case the donor BS terminates S1 connections towards Evolved Packet Core (EPC) and the relay node can be seen as a cell managed by the donor BS from the EPC and neighbor BSs point of view. In this architecture, some legacy MAC/RLC/PDCP protocols would need to be modified.

2.2. IEEE 802.11n

One of the most pervasive wireless technologies for use in homes, offices, and other multiple scenarios is the IEEE 802.11 technology. 802.11n is the version that offers more peak data rate, reaching more than 100 Mbps. The used bandwidths are 20 or 40 MHz in the bands of 2.4 or 5 GHz [14]. The physical layer data rate can even exceed 300 Mbps provided 2×2 spatial multiplexing and 40 MHz bandwidth. This high performance is achieved through a range of new technological solutions such as: Multiple Input Multiple Output (MIMO) schemes, Spatial Multiplexing (SM), spatial mapping (including beamforming), Space-Time Block Coding (STBC) and Low-Density Parity Check (LDPC) coding.

2.3. Media Independent Handover

The IEEE 802.21 MIH is specially designed to perform handovers between different IEEE 802 architectures (802.3, 802.11, 802.16) [9]. However, other 3GPP technologies such as LTE-A can be included in its operation. Next generation handsets are ideal candidates for installing and using the MIH protocol since they have multiple radio access interfaces (UMTS, LTE, WiFi, etc). Moreover, MIH protocol can easily be included in the application layer.

Mainly, MIH is based on the exchange of messages reporting a subset of PHY/MAC layer events. The MIH functions are enabled by an entity called MIH Function (MIHF), which provides MIH Event Services (MIES), MIH Command Services (MICS), and MIH Information Services (MIIS). Figure 1 shows the main entities in the MIH protocol, as well as the events and

commands generated by these entities. The MIES detects changes in the link layer and initiates events from both local and remote interfaces. The MICS offers the MIH-User control over the connection properties that are relevant to the handover. Finally, the MIIS provides information on different heterogeneous networks. There are specific events to notify link power going down, link disconnection, degradation of the channel, link handover is imminent, and so on.

The different events and commands are defined in the MIH standard. Depending on where the information is originated, the MIHF entity could receive or transmit reports on the configuration and condition of the radio access networks the MN is detecting. If the information is obtained remotely, the local MIHF entity receives information from the remote MIHF entity that is located in the network. However, when information is received from the lower layers of the protocol stack, this is obtained through service primitives that define the interface. For example, if the signal strength received by a remote entity falls below a threshold, then lower layers detect it and send a Link Going Down event to the MIHF entity. This entity communicates with the remote MIHF through Remote MIH Events. Once the event reaches the local MIHF entity, it is forwarded via a MIH event to the MIH-User. In the same way as with events, local MIH-User can send a command to make lower layers perform a specific operation. For example, thresholds can be adjusted, the active link quality can be measured in terms of Signal to Interference plus Noise Ratio (SINR), Bit Error Rate (BER), etc. Finally, to integrate MIH within 3GPP systems there is no need for new protocols to access MIHF services. These services can be mapped to those already existing in 3GPP [9].

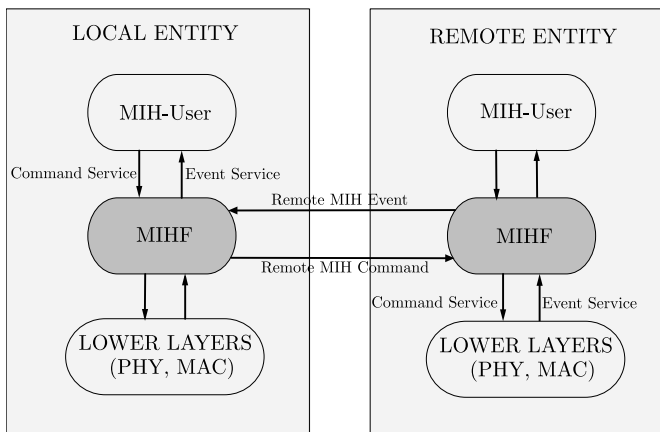

FIGURE 1. Media independent handover operation.

2.4. Localization

User positioning can significantly reduce the complexity of the relay selection process. LTE-A specification considers MN localization through the LTE Positioning Protocol (LPP) and LPP Annex (LPPa) [15, 17]. Several different positioning methods are mentioned in the standard, namely: Observed Time Difference of Arrival (OTDoA), Assisted-Global Navigation Satellite System (A-GNSS) and Enhanced-Cell ID (E-CID). Implementation details are omitted here but the interested reader can refer to the standard for further information. All of these positioning methods are based on measurements collected by the MN or the BS. The Mobility Management Entity (MME) is the entity that receives the request for the localization of a MN from another entity such as a MN, BS or other nodes. Then, the MME sends a location service request to the Enhanced Serving Mobile Location Centre (E-SMLC), which will execute the positioning procedure through LPP and LPPa protocols. The SLs interface defined between E-SMLC and MME serves as a tunnel for the E-SMLC to transparently carry LPP and LPPa protocols through the MME, in addition to transport the Location Services Application Protocol (LCS-AP) messages and parameters. The study of different positioning methods is outside the scope of this article. However, it is worth noting that in LTE-A advanced location methods are available and can be used by the relay selection mechanism proposed in this paper.

Concerning the signaling overhead of user positioning, note that the periodicity of LPP methods must be higher than 0.5 s, which is the typical period of measurement reports sent by Long Term Evolution (LTE) mobile nodes. Considering that the MIIS entity is independent for each BS, the data base burden is limited to hundreds of inserts per second, which is an order of magnitude lower than the current capacity of commercial data bases

3. MIH-Driven Relay Selection Mechanism (MIDRES)

Cell-edge users suffer a reduction in data rates as compared with users who are close to the BS because the SINR is usually lower. This causes some unfairness among nodes due to their location. Moreover, considering that the spectral efficiency requirements set by the International Telecommunication Union (ITU) for 4G technologies are very demanding [13], both IEEE and 3GPP have decided to use relays to increase the cell-edge user spectral efficiency. The use of relays decreases the transmission range, increasing the probability of receiving the data correctly, allowing higher data rates than those achieved without relays.

Figure 2 shows the scenario under study. Three types of nodes are distinguished: a BS, MNs and MRs. The MN that is experiencing bad channel conditions is referred to as Solicitor Mobile Node (SMN). In this scenario there exist MNs receiving from the BS (active nodes) and MNs in the idle mode (passive nodes), which are the only ones that can relay signals from or to the SMN. Both MNs and MRs have two interfaces: an LTE-A interface to

communicate directly with the BS and a WiFi interface for the MN to MR link. It is considered that the link between the MR and the MN is implemented with IEEE 802.11n standard [14]. At baseline, all MNs are connected with LTE-A unless the use of mobile relaying implies higher data rates.

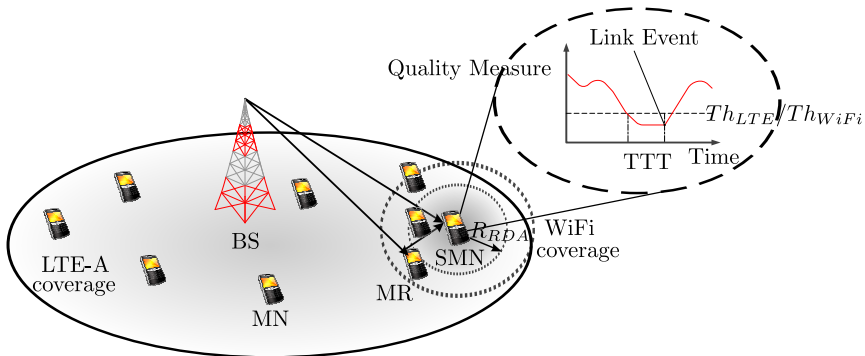

FIGURE 2. Simulation scenario under study.

The MIH-Driven Relay Selection Mechanism (MIDRES) proposed in this paper uses MIH signaling to define a routing and handover mechanism for mobile relaying in Fourth Generation (4G) mobile systems. In this paper, it is assumed that nodes can have both LTE-A and Wireless Fidelity (WiFi) radio interfaces simultaneously active. When handover occurs, the packet route switches from one technology to another and the old technology transits to the idle state. As shown in Figure 2, if a MN connected to LTE-A experiences a SINR level below the quality threshold, Th_{LTE} , during Time to Trigger (TTT) seconds, then a Link Going Down (LGD) event is sent from lower layers to the MIH-User situated in upper layers. Similarly, a LGD event could be initiated and sent to the MIH-User in the MR. These events initiate the handover procedure.

It is assumed that all MNs and the BS are MIH-Users and implement MIHFs. In the BS the MIHF is also known as Point of Service (PoS). As shown in Figure 1, MIH communication among entities such as BSs or MNs is carried out through MIHFs. The destination of an event is established with a subscription mechanism that enables MIH-Users to subscribe to particular event types located either in the same equipment or in remote nodes. The main difference between the MIHFs of BSs and MNs is that MNs announce events from lower layers to the subscribed entities whereas the BS initiates and manages possible handovers among technologies.

In mobile relaying three different situations may occur:

1. **Situation 1.** The SMN is connected to LTE-A and the SINR level is lower than Th_{LTE} . In this case, MIDRES initiates the handover procedure to select the most appropriate MR.

2. **Situation 2.** The mobile relaying for a MN is active and either the LTE-A or the WiFi interface goes below the quality threshold. Then, MIDRES initiates the procedure looking for a new available MR or making a handover back to LTE-A.
3. **Situation 3.** The mobile relaying for a MN is active and the LTE-A SINR level of the MN is higher than the quality threshold¹. In this case, MIDRES initiates the procedure searching for the best connection configuration.

3.1. Situation 1

Figure 3 shows the exchange of messages when mobile relaying provides better throughput to the SMN than the direct LTE-A link. The figure also shows the connection state for LTE-A and WiFi. In this situation, MIDRES procedure includes the following phases:

1. **Monitoring and Notification.** When the SMN detects that the SINR level is below Th_{LTE} during TTT seconds, the lower layers send a LGD event to the MIH-User that forwards this event to the BS with the Link_Parameters_Report.indication message.
2. **Information Query.** The BS MIH-User sends a Get_Information.request message towards the Information Server (IS) asking which relay nodes are candidates. The BS could attach a radius called R_{RDA} , centered at the indicated location. Otherwise, the IS would decide upon this radius. At this point, the IS can run the proposed Relay Discrimination Algorithm (RDA) to reduce MIH signaling. Basically, the RDA consists in selecting those cooperative MNs that are at a distance less than R_{RDA} from the SMN. Note that the IS can periodically estimate the location of all MNs using E-SMLC described in Section 2.4. Finally, the IS entity responds with a Get_Information.response message that includes the list of candidate MRs.
3. **Resource Availability Check.** After the confirmation of available relays, the BS sends a MIH_Net_HO_Candidate_Query.request to the MN providing the list of candidate MRs. The MN indicates the required resources in the MIH_Net_HO_Candidate_Query.response message. At this stage the SMN activates its WiFi interface and sends periodic HELLO messages so that the candidate MRs can detect its presence. Next, the BS polls all MR candidates on the feasibility of the connection by sending a MIH_N2N_HO_Query_Resources.request. Once the candidates receive this message, they activate their WiFi interface and measure the link quality with the SMN, analyzing the received HELLO messages power and therefore the link throughput. After this measure, each relay node sends the result to the BS in a MIH_N2N_HO_Query_Resources.response message through the LTE-A interface. Note that, in addition to this information, the BS can estimate the mean throughput of its link

¹It is considered in this paper that this threshold is again Th_{LTE} .

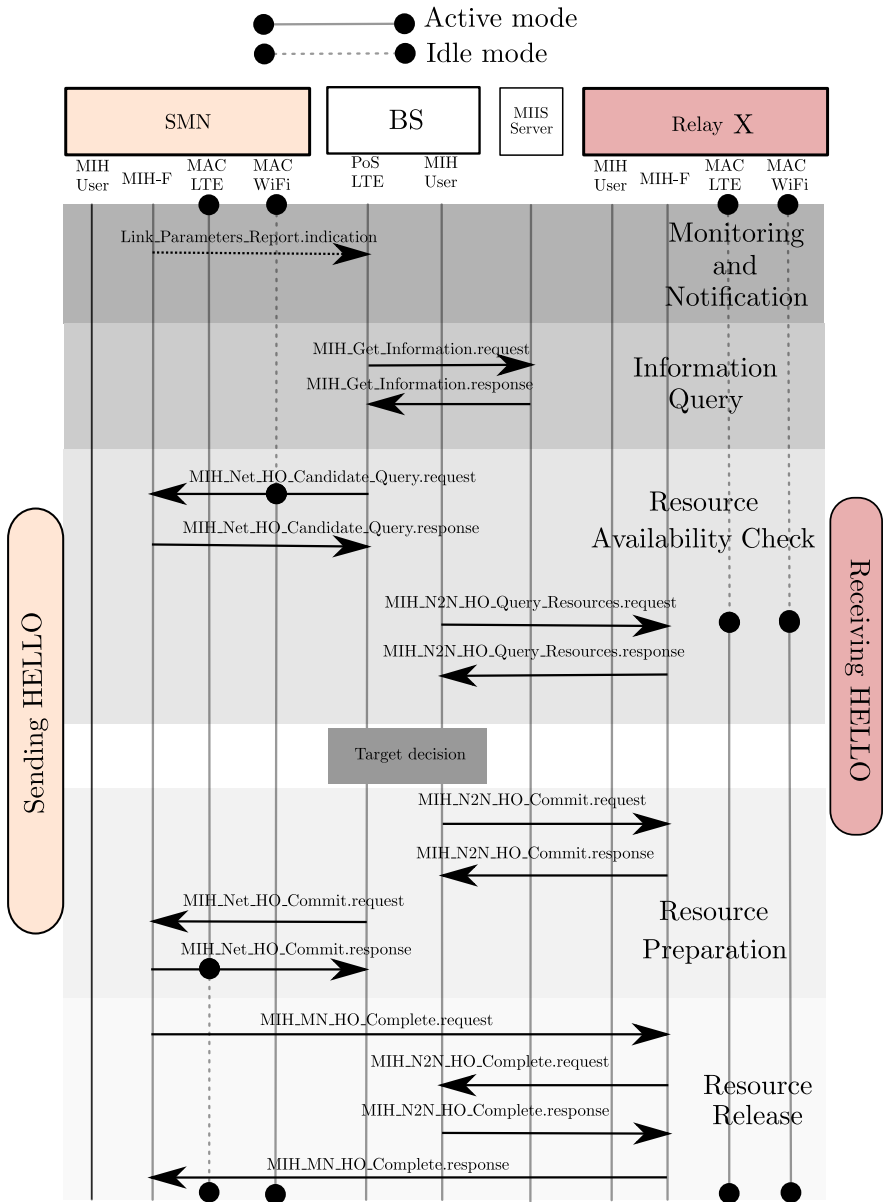

FIGURE 3. MIDRES procedure to configure a MR.

with the MR since the LTE-A connection is active at this stage. Using these data, the BS decides on the best connectivity option, that is, remain connected to LTE-A or use a MR.

4. **Resource Preparation.** If the best option is to use a relay then the process continues. The BS sends a `MIH_N2N_HO_Commit.request` message to the selected MR marking the beginning of the routing process. The relays answers with a `MIH_N2N_HO_Commit.response`. From this point on, the relay will route all packets from the BS to the SMN. For all purposes, the relay will be connected with the BS as another user. To distinguish the final destination (it may be that the relay receives a packet for itself), the relay will only have to inspect the IP packet's destination address. Of course, for this to be viable, it is necessary that the relay possesses routing capabilities. In the same way, the BS informs the SMN about the decision with a `MIH_Net_HO_Commit.request` message to commit handover towards the specified relay. The new radio interface connection is established and the MN sends a `MIH_Net_HO_Commit.response` to the BS.
5. **Resource Release.** In the last stage mobile relaying must be confirmed. The SMN sends a `MIH_MN_HO_Complete.request` to the selected relay that answers with a `MIH_MN_HO_Complete.response`. The completion is also reported to the BS with a `MIH_N2N_HO_Complete.request` and its corresponding response message.

At this point it is worth discussing about another alternative of MIDRES in which the SMN measures the quality of the candidate MRs. Note that the decision of making the MRs measure the channel is aimed at reducing the handover delay. With the current proposal of MIDRES, the SMN is the only one sending HELLO messages and this reduces the contention problems. With the other alternative, all relay nodes should content to seize the channel and therefore there would be potential collisions and hidden node problems. As a consequence the time required for the handover will be much higher.

3.2. Situation 2

Figure 4 shows the exchange of messages when, in an active mobile relaying, the power level of the WiFi radio interface falls below the threshold², Th_{WiFi} . When this happens the MR sends to the BS the corresponding `Link_Parameters_Report.indication` message. From this moment all phases of the MIDRES procedure are identical to the Situation 1, except the resource release phase. Now the BS sends a `MIH_N2N_HO_Complete.request` to the old relay to release the assigned resources. The old relay answers with a `MIH_N2N_HO_Complete.response`. Note that the procedure also contemplates the possibility of the direct LTE-A link being the most convenient one. In this case, the MN sends the `MIH_MN_HO_Complete.request` message directly to the BS.

3.3. Situation 3

When the LTE-A SINR level at the SMN is higher than the quality threshold, an event is sent from its lower layers to the MIH-User. This Link-Up event

²Note that the procedure would be the same in case of degradation of the LTE-A link

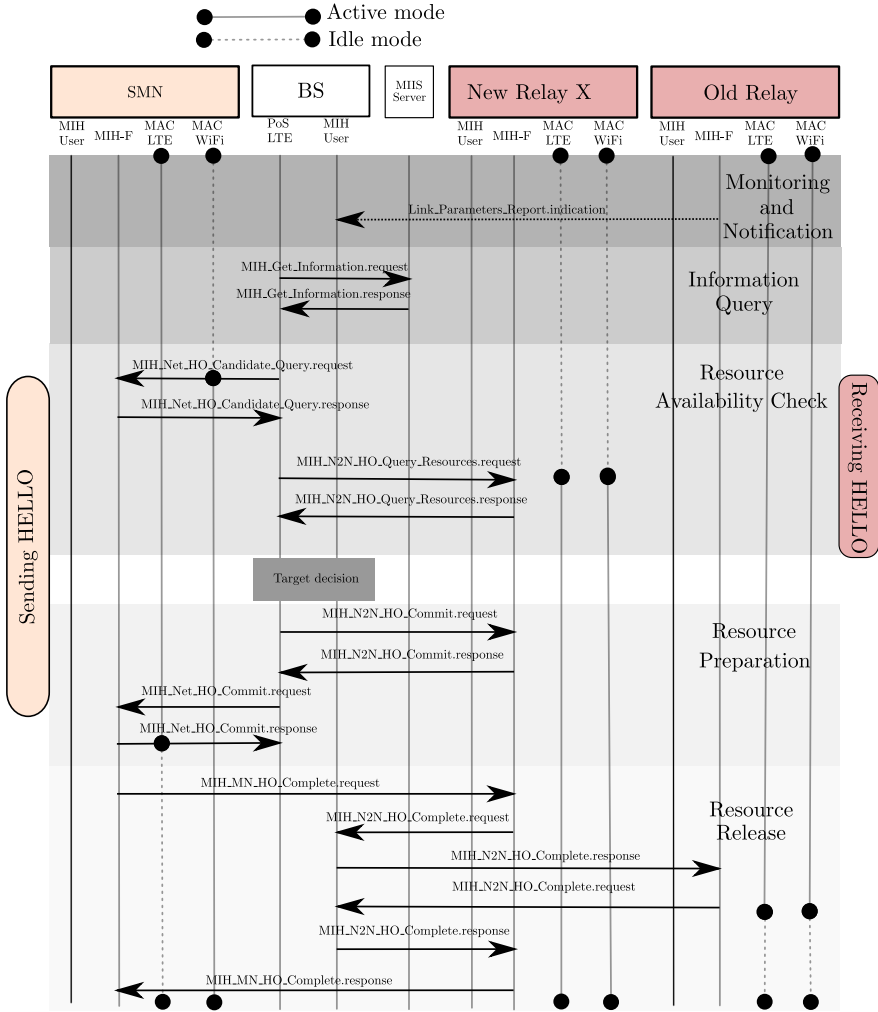

FIGURE 4. MIDRES procedure to change the MR.

is notified by the SMN to the BS through a `Link_Parameters_Report.indication` message. The signaling procedure is the same as in situation 2 with the possibility of not selecting any new MR.

4. Assessment methodology and system modeling

Assessment methodology in this work was based on system level simulations. The baseline for the simulation methodology and system modeling are the guidelines provided by [19] for the evaluation of International Mobile Telecommunications Advanced (IMT-Advanced) technologies. Nevertheless,

some simplifications have been considered in order to reduce the complexity of the methodology proposed in [19].

A simple network layout was assumed with an isolated cell with a unique BS in its center that serves a circular area with radius R . A population of MNs is spatially uniformly distributed within the cell area. The initial position of a user u is randomly taken in polar coordinates from two uniform distributions, being the radius, $r_u = \sqrt{U[0, R^2]}$ and the angle $\alpha_u = U[0, 2 \cdot \pi]$.

Although in this model the cell layout deviates from the original one specified in [19], the same SINR Cumulative Density Function (CDF) as in the original layout is found in the cell of the new layout. This is achieved thanks to a position-SINR relation model specifically designed for this purpose. Using a complete simulator, with the original layout, the received SINR CDFs after antenna receiver were obtained for the different evaluation scenarios: Indoor hotspot (InH), Urban microcell (UMi), Urban macrocell (UMa) and Rural Macrocell (RMa). Then for each user, position has a one-to-one correspondence with the SINR value according to the following formula:

$$SINR_u = CDF^{-1} \left(1 - \left(\frac{r_u}{R} \right)^2 \right), \quad (4.1)$$

where CDF is the SINR CDF for any particular scenario, and CDF^{-1} is its inverse. It is worth noting that in this model the higher SINR values are obtained for the lower distances to the BS.

Multipath fading is not emulated in this assessment. Then, SINR values represent wideband measures. In LTE-A, channel capacity was obtained for each user translating the wideband SINR value to a throughput value through Look-Up Table (LUT) calculated in link level simulations. Different LUT were obtained for each evaluation scenario and MN multi-antenna configuration. Similar throughput vs wideband SINR curves are found in [2]. Both, the complete system level simulator and the link level simulator were validated in the framework of the Wireless World Initiative New Radio + (WINNER+) project [20] being used in the IMT-Advanced candidate evaluation carried out within ITU-R. Concerning WiFi, channel capacity is a function of distance between transmitter and receiver as described in [21].

MNs are in constant motion throughout the simulations with a fixed speed and follow a model similar to the Random Waypoint Model [18]. The MN path comprises a sequence of movement intervals in which direction is fixed. In each movement interval the starting point is the ending point of the previous interval, while the ending point is drawn from a spatially uniform distribution over the cell area.

MNs can be in two states and do not change this state during the simulation. MNs in idle state can relay signals while MNs in active state are receiving data and cannot relay signals. Concerning the traffic model, for the sake of simplicity a Constant Bit Rate (CBR) traffic source has been used. With respect to scheduling, LTE-A performs a proportional fair allocation of resources.

Scenarios/Speed (km/h)/Radius (m)	InH/3/20 UMi/3/67
	UMa/30/167 RMA/120/577
Number of Active Nodes	10
Number of Idle Nodes	50
Packet Size (bytes)	128
Application Rate (Mbps)	4 (InH)/ 2 (UMi,UMa)
TTT (ms)	100
WiFi Carrier frequency (GHz)	2.4
WiFi Bandwidth (MHz)	20
WiFi Transmission Power (dBm)	15
WiFi Antenna Configuration	1x1
LTE-A Antenna Configuration	1x2
LTE-A Bandwidth (MHz)	10

TABLE 1. Basic parameters used in the performance assessment.

Finally, concerning MIH signaling, it is worth noting that the simulation tool models the MIH messages and accounts for the overhead that this additional signaling entails. Only the MIH subscription messages that can be originated both locally and remotely have not been considered in the signaling burden. Concerning handover delay, the simulation takes into account the idle to connected mode latency in LTE-A and all the time required in the discovery and connection phase of the WiFi interface.

Additional assumptions of the simulation methodology are indicated in Table 1.

5. Results and Discussion

MIDRES was designed to make MIH protocol compatible with LTE-A system. With this aim, it is necessary to perform an optimal threshold setting to find a trade off between channel quality improvement and signaling overhead. Hence the importance of Section 5.1. On the other hand, MIH signaling can cause a performance hit as the number of candidate relay nodes increases since signaling overhead increases too. Section 5.2 presents some results concerning the RDA algorithm that reduces the amount of candidate relays and, consequently, the signaling overhead. Next, the effect of the MN speed on the performance of mobile relaying is evaluated in Section 5.3. Finally, Section 5.4 is devoted to the study of cost savings that result from using mobile relaying in LTE-A.

5.1. Threshold evaluation

The study of the quality threshold set by the MIH-User is of paramount importance to reach an equilibrium between signaling load and system performance. There exist three different thresholds:

1. WiFi threshold (Th_{WiFi}): If the WiFi link falls below this threshold the MR replacement process starts.
2. LTE-A threshold (Th_{LTE}): This threshold activates the search of a MR to support the connectivity.
3. LTE-A reactivation threshold: If the LTE-A signal surpasses this threshold then the SMN could be back to the single-hop LTE-A communication.

For the sake of simplicity, in this paper Th_{WiFi} is set to -82 dBm and the reactivation threshold equals Th_{LTE} . Therefore, this section only focused on the optimization of the LTE-A threshold based on, firstly, the minimization of the number of required relays and, secondly, the maximization of the Cell-edge User Throughput (CEUT).

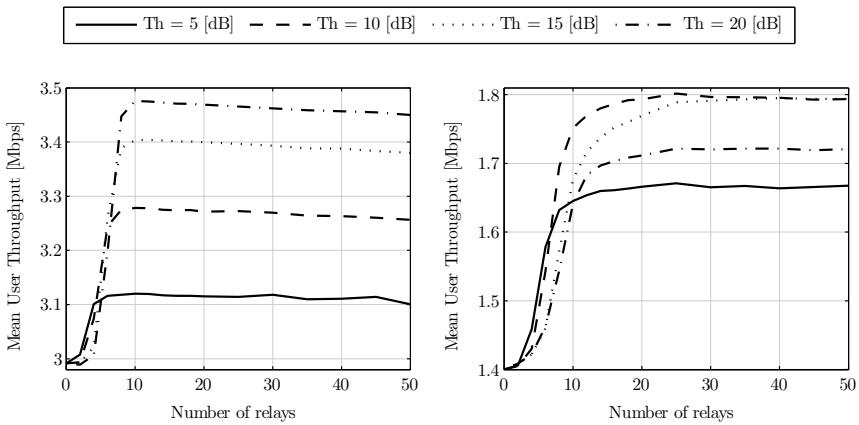

FIGURE 5. Threshold analysis for InH (left) and UMi (right) scenarios.

Figure 5 evaluates the Mean User Throughput (MUT) with an increasing number of MR available in the scenario³. Two scenarios (InH and UMi) and four thresholds are depicted. The number of active nodes in the cell is 10 following the guidelines provided by [19].

It can be observed that mobile relaying improves remarkably system performance. In the InH scenario, the higher the threshold is the better the performance. It is always beneficial to use a MR since, in such a small scenario, the WiFi interface exhibits higher data rates and reducing the hop length in LTE-A also improves performance. However, there is an optimum in the number of MRs, which in the InH case is around 10. With more than 10 MRs the additional diversity in the selection of the best MR does not compensate the increase in signaling. To sum up, for small scenarios the LTE-A threshold must be set as high as possible but the candidate set must be restricted to 10.

³Note that 0 MR represents the scenario without mobile relaying.

Th_{LTE} [dB]	10	11	12	13	14	15
CEUT [Mbps]	1.5797	1.5916	1.5630	1.5524	1.5098	1.4377

TABLE 2. CEUT for different Th_{LTE} .

However, for wider scenarios the selection is more challenging. As an example, this paper analyzes the UMi case. If Th_{LTE} is too small, the system does not benefit from the availability of relays. In fact, with a small number of available relays it is better to choose a lower threshold since with higher probability the relay will not be beneficial for the link. On the contrary, if Th_{LTE} is too high, with higher probability the WiFi link would be worse than the LTE-A link and the system would waste resources on useless signaling. Therefore, an in-depth analysis is needed.

Figure 5 shows that the minimum number of relays to get good diversity is around 20. Note that this number is higher than in the InH case, since more relays are required to have the same diversity in the selection of the best MR. On the other hand, Figure 6 shows the MUT CDF for this required minimum number of MRs. In the UMi scenario the optimum threshold changes depending on the objective. In order to maximize the CEUT (5th percentile of the CDF), the best threshold is between 10 and 15 dB. In fact, the optimum is 11 dB as shown in Table 2.

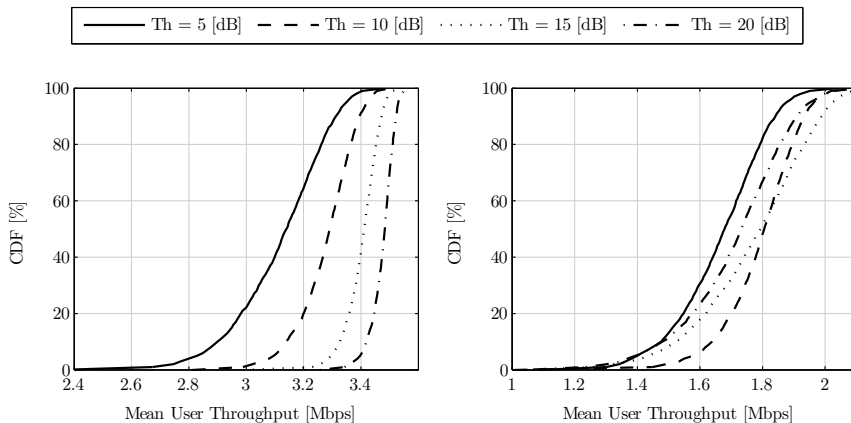

FIGURE 6. CDF of the mean user throughput for InH (left) and UMi (right) scenarios.

As a guideline, for the UMa scenario the required minimum number of MRs is around 25 and the optimum threshold is 12 dB. Concerning the RMa scenario, the number of relays is around 35 and the optimum threshold is again 12 dB.

5.2. Performance evaluation of the Relay Discrimination Algorithm (RDA)

The Relay Discrimination Algorithm (RDA) is useful for reducing the MIH signaling. Without the use of this algorithm by the MIIS server, the BS would send a MIH_N2N_HO_Query_Resources.request to all idle nodes. As the number of cooperative nodes increases the MIH protocol could be unfeasible. Thus, RDA algorithm only requires that the MIIS Server knows the MNs location. As discussed in Section 2.4, LTE-A standard encompasses several positioning methods that can be used for this purpose.

In this section a UMa scenario is assumed with $Th_{LTE} = 12$ dB. Figure 7 shows the MUT varying the parameter R_{RDA} for an increasing number of MRs. It can be seen that, when restricting the search area, a larger number of cooperative relay nodes is required to get the same MUT since the probability of a relay being in the search area is smaller. However, when the number of available relays increases, there is an increment in the signaling load that can be reduced with the RDA. In fact, the optimum value of R_{RDA} depends on the number of available MRs as shown in Figure 7. For a higher number of cooperative nodes a smaller search radius must be used, since this reduces the signaling overhead.

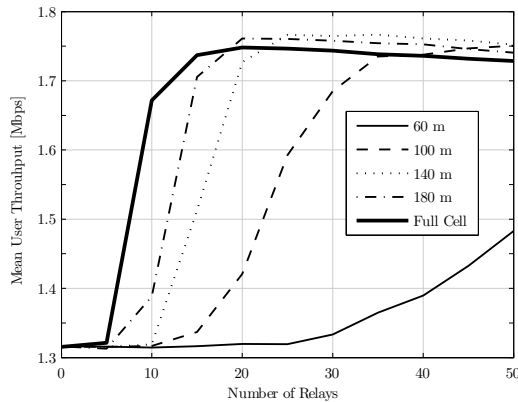

FIGURE 7. Mean user throughput for different R_{RDA} values in a UMa scenario.

5.3. Velocity impact evaluation in performance

This section evaluates the effect of the MN speed on the mobile relaying performance. A UMa scenario was simulated in which user speed augmented from 40 to 90 km/h. Figure 8 shows that the performance of mobile relaying deteriorates as the user speed increases. This is due to the fact that the mobile relaying links are less stable and signaling and handover delay degrade the MUT. However, even with 90 km/h mobile relaying is preferred as compared with the conventional single-hop scenario. This is due to the fast-switching capacity of MIDRES and the good coverage of WiFi in outdoor.

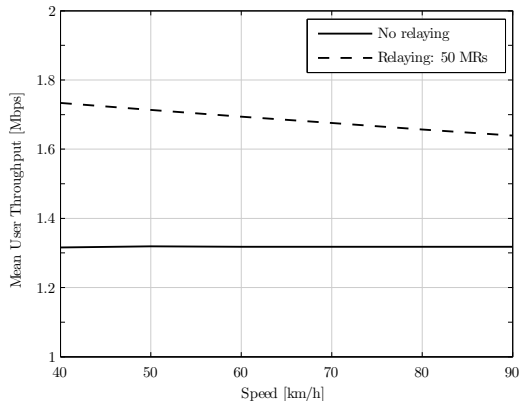

FIGURE 8. Mean user throughput for different values of MN speed in a UMa scenario.

5.4. Deployment cost in an LTE-A system

LTE-A systems are designed to increase end user data rates as compared with Third Generation (3G) systems. These high data rates may only be offered to users near the BS, creating a situation of unfairness between MNs. However, operators aim to offer higher rates to as many users as possible with the least possible cost. The use of MRs is considered as a key factor to increase the coverage thus deploying a lightweight wireless system.

A simplified high level financial analysis of the LTE-A deployment was performed to assess the reduction of costs that can be achieved through the use of MRs. This study was carried out for a fictive region of an area of 200 square kilometers similar to that described in [22], which represents a typical European city scenario. Although the total population was assumed to be 500,000 people, the LTE-A network was expected to cover only 70% of the population. In particular, according to [22], the number of LTE-A subscribers served by one operator in this fictitious scenario was predicted to be, at most, 55,000 by the third year. That is to say, a population density of 275 people per km^2 is considered.

In order to study the real economical impact of mobile relaying, a quality criterion for Cell-Edge User Spectral Efficiency (CEUSE) of 0.12 b/s/Hz was fixed. Multiple simulations were performed to assess the number of base stations required to achieved such quality criterion in a scenario with the above-mentioned population density for different cell radius configurations with and without relaying. A UMa scenario was considered. For each cell radius configuration, the proper number of total users was calculated according to the fixed population density. The number of active MNs in each cell was 1/3 of this total number, being the rest of users in idle state. The number of

possible MRs in each cell is a percentage of the number of idle users. The considered percentages range from 0% (network without relaying) to the 100% in steps of 20%. In all simulations $Th_{LTE} = 12$ dB.

As shown in Figure 9, a network without relaying reaches the quality criterion with a cell radius of 192.35 m, whereas with a percentage of 80% among idle nodes, coverage increases by 7.46 m, which represents an increase of 7.91%. With 100% of relay nodes coverage increases 19.35 m, that is, a 21.16%. Note that without using relaying and until a percentage of 60% of idle nodes, the CEUSE is almost equal for different cell radius.

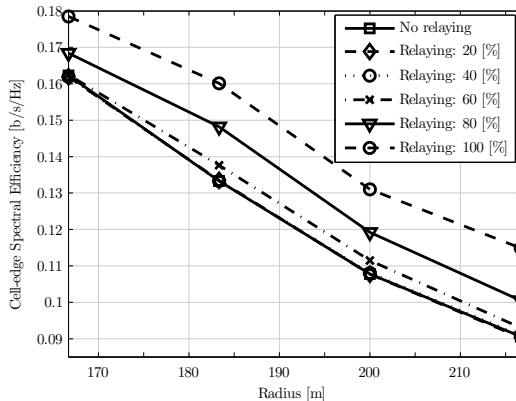

FIGURE 9. Cell-edge user throughput versus cell radius with different percentages of cooperative nodes.

For the financial analysis, Capital Expenditure (CAPEX) and Operational Expenditure (OPEX) per year were calculated. In the CAPEX analysis it was assumed that the mobile operator deploys LTE-A using the available infrastructure. Therefore, civil work expenditures were not taken into account, neither the cost of acquiring spectrum licenses, since operators may use frequency bands of current technologies to minimize the cost of LTE-A. Finally, CAPEX encompasses LTE-A equipment cost (50 k€ per site [23]), labor-related deployment cost (10 k€ per site) and upgrading the existing backhaul (2 k€ per site). The number of sites (composed of three cells in this study) multiplied by the investment cost per site yields the overall operator network investments. By combining the coverage area and the BS range, previously calculated, it is easy to obtain how many BSs are required.

On the other hand, OPEX accounts for site rental (10 k€ per site per year [24]), data backhaul costs (5 k€ per site [24]), maintenance (3 k€ per site [24]), marketing cost (1.85 € per person [23]), administrative costs (addition of 10% of other running costs [23]) and the subsidy paid by the operator to reduce the price of new mobile terminals, thus facilitating the migration of subscribers (160 € per subscriber [23]). Similarly, OPEX was calculated

Scenario	CAPEX [M€]	OPEX [M€]
LTE	43.09	33.23
LTE-A (80%)	39.93	31.07
LTE-A (100%)	35.57	28.11

TABLE 3. Cost analysis of the LTE-A deployment.

multiplying the number of sites by the running cost per site plus terminal subsidies, considering that the migration of subscribers to the new network occurs in progressive stages during these three years. Note that only one terminal replacement per user was supposed in this study. Moreover, OPEX is increased with the annuity payment of a loan for CAPEX requirements over this period at an interest rate of 4%.

Table 3 shows the resulting deployment costs. For instance, according to the simulations, CAPEX varies from around 43 M€ with a basic LTE system to around 36 M€ when mobile relaying is added. This represents a 17.47% savings.

6. Conclusions

LTE has been designed as a future technology to cope with upcoming user requirements. This paper has proposed a new relay selection mechanism based on the use of MIH signaling. This allows including mobile relaying as an additional technique in an LTE-A system. The implementation of mobile relaying in LTE-A certainly enhances the overall system performance. In addition, the proposed relay selection procedure is a low-cost solution because no modifications of the LTE-A system architecture are required for its implementation.

However, the MIH-Driven Relay Selection Mechanism must be set up carefully and several aspects have been discussed throughout the paper. First, SINR threshold that triggers the selection of relay must coincide with the point in which the cellular system is unable to cover user quality of service. Moreover, the selection of the relay entails additional signaling that must be reduced to a minimum to make the most of mobile relaying. A simple technique has been shown in this paper to highlight the importance of this signaling overhead.

Finally, this article has shown the relevance of mobile relaying to reduce deployment costs. In an typical European city scenario, the reduction of CAPEX and OPEX is about 17.47% and 15.39%, respectively.

References

- [1] ITU World Telecommunication/ICT Indicators database, *Global ICT developments, 2000-2010*. ITU Statistics (<http://www.itu.int/ict/statistics>), 2010.
- [2] Martin-Sacristan D., Monserrat J.F., Cabrejas J., Calabuig D., Garrigas S. and Cardona N., *On the Way towards Fourth-Generation Mobile: 3GPP LTE and*

- LTE-Advanced*. EURASIP Journal on Wireless Communications and Networking, vol. 2009, 10 pages, 2009.
- [3] 3GPP TR 36.913 V10.0.0, *Requirements for further advancements for Evolved Universal Terrestrial Radio Access (E-UTRA) (LTE-Advanced) (Release 10)*. Technical Specification Group Radio Access Network, 2011.
- [4] IEEE 802.16j, *IEEE Standard for Local and metropolitan area networks Part 16: Air Interface for Broadband Wireless Access Systems, Amendment 1: Multi-hop Relay Specification*, 2009.
- [5] 3GPP TR 36.806 V9.0.0, *Relay architectures for E-UTRA (LTE-Advanced) (Release 9)*. Technical Specification Group Radio Access Network, 2010.
- [6] Xiao L., Fuja T. E. and Costello D. J., *Mobile Relaying: Coverage Extension and Throughput Enhancement*. IEEE Transactions on Communications, 2010.
- [7] Vanganuru K., Puzio M., Sternberg G., Shah K. and Kaur S., *Uplink System Capacity of a Cellular Network with Cooperative Mobile Relay*. Wireless Telecommunications Symposium, 2011.
- [8] Li Z. and Shen H., *Game Theoretic Analysis of Cooperation Incentive Strategies in Mobile Ad-hoc Networks*. IEEE Transactions on Mobile Computing, 2011.
- [9] IEEE 802.21, *Draft Standard for Local and Metropolitan Area Networks: Media Independent Handover Services*. IEEE P802.21, D9.0, 2008.
- [10] Bae S. J., Chung M. Y. and So J., *Handover Triggering Mechanism Based on IEEE 802.21 in Heterogeneous Networks with LTE and WLAN*. Information Networking (ICOIN), 2011.
- [11] Seol J. and Chung J., *IEEE 802.21 MIH based Handover for Next Generation Mobile Communication Systems*. Innovations in Information Technology, 2007.
- [12] Bültmann D., Luo J. and Schulz E., *Media Independent Handover Enabled Advanced Mobility Management and its Functional Mapping*. Communications, Circuits and Systems, 2008.
- [13] ITU-R M.2133, *Requirements, evaluation criteria and submission templates for the development of IMT-Advanced*. REPORT ITU-R, 2008.
- [14] IEEE 802.11n, *Part 11: Wireless LAN Medium Access Control (MAC) and Physical Layer (PHY) Specifications. Amendment 5: Enhancements for Higher Throughput*, 2009.
- [15] 3GPP TS 36.305, *Stage 2 functional specification of User Equipment (UE) positioning in E-UTRAN*. Technical Specification Group Radio Access Network, 2011.
- [16] 3GPP TS 36.355, *LTE Positioning Protocol (LPP)*. Technical Specification Group Radio Access Network, 2011.
- [17] 3GPP TS 36.455, *LTE Positioning Protocol A (LPPa)*. Technical Specification Group Radio Access Network, 2011.
- [18] Johnson D. B. and Maltz D. A., *Dynamic source routing in ad hoc wireless networks* in Mobile Computing, edited by Torrrasz Imielinski and Hank Korth, chapter 5, pages 153–181, Kluwer Academic Publishers, 1996.
- [19] ITU-R M.2135, *Guidelines for evaluation of radio interface technologies for IMT-Advanced*. REPORT ITU-R, 2009.
- [20] WINNER+ Evaluation Group, <http://projects.celtic-initiative.org/winner+/WINNER+%20Evaluation%20Group.html>.

- [21] Green D.B. and Obaidat A.S., *An accurate line of sight propagation performance model for ad-hoc 802.11 wireless LAN (WLAN) devices*. Communications, 2002.
- [22] WiMAX Forum. *A Comparative Analysis of Spectrum Alternatives for WiMAX Networks with Deployment Scenarios Based on the U.S. 700 MHz Band*. Wimax Forum Website, 2008.
- [23] Forge S., Blackman C. and Bohlin E. *The demand for future mobile communications markets and services in Europe*. IPTS Technical Report Prepared for the European Commission - Joint Research Centre, 2005.
- [24] Johansson K., Furuskar A., Karlsson P. and Zander J., *Relation between base station characteristics and cost structure in cellular systems*. IEEE PIMRC-2004, 2004.
- [25] Analysys Research, *Global Mobile Broadband: Market potential for 3G LTE (Long Term Evolution)*, 2008.
- [26] Pyramid Research, *Market Opportunity Analysis: Mobile Broadband Notebook PCs*, 2007.

Jorge Cabrejas
Camino de Vera S/N
46022, Valencia
Spain
e-mail: jorcabpe@iteam.upv.es

Pablo Gualda
e-mail: paguario@iteam.upv.es

Jose F. Monserrat
e-mail: jomondel@iteam.upv.es

David Martin-Sacristan
e-mail: damargan@iteam.upv.es