

UNIVERSIDAD POLITECNICA DE VALENCIA

ESCUELA POLITECNICA SUPERIOR DE GANDIA

I.T. Telecomunicación (Sist. Electrónicos)



**UNIVERSIDAD
POLITECNICA
DE VALENCIA**



**ESCUELA POLITECNICA
SUPERIOR DE GANDIA**

“Multi-sensor Olfactory System with temperature control.”

TRABAJO FINAL DE CARRERA

Autor/es:
Daniel García Rodríguez

Director/es:
Santiago Jose Flores Asenjo

GANDIA, 2013

2013

Multi-sensor Olfactory System.

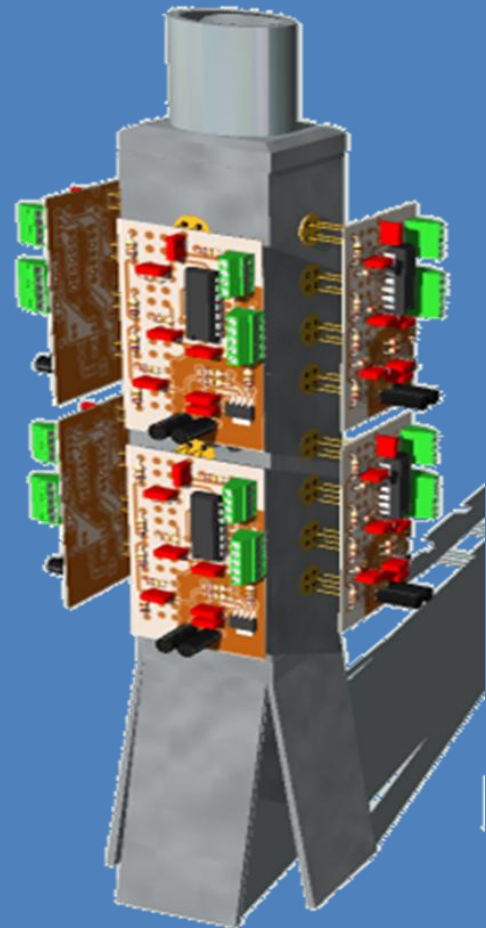
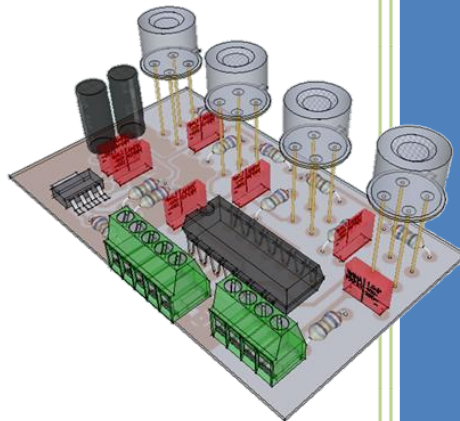
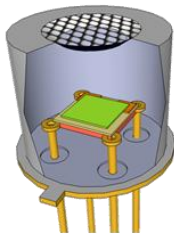

Daniel García Rodríguez

Final Project

08/07/2013

INDEX

INTRODUCTION:	1
Why an electronic nose?	1
Our Project goals	2
HARDWARE.....	3
Sensors.....	3
Operating principle of semiconductor type gas sensors.....	3
Used models	5
Measuring circuit.....	12
Sensor Preheating.....	13
Heater voltage dependency	14
Socket sensors	14
The Sensor Circuit.....	15
Regulator	16
Output Capacitor	16
Setting The Output Voltage	16
Enable Pin	17
Regulator Circuit.....	17
Operational.....	18
OP 400	18
Operational Circuit	19
Design of PCB.....	19
Top layer and Bottom layer	20
Top Layer	20
Bottom layer	20
Power supply	21
Steel piece	22
Air injection system	22
Air pump	22
Electrovalve	23

Circuit in order to use the electrovalve.....	24
Acquisition Board: NI USB-6218	27
Specifications:.....	27
Connection with the acquisition card NI USB-6218:	28
Final assembly.....	29
FUTURE IMPROVEMENTS	30
CONCLUSION	32
BIBLIOGRAPHY	33

INTRODUCTION:

Why an electronic nose?

Over the past years has discovered that dogs with heightened olfactory sensitivity are able to recognize patients with different types of cancer. Already in the 1980s was a case of a dog who detected a melanoma in moles of his master. After an investigation, it was concluded that the animal had been able to recognize this disease in a 41 of effectiveness. Since then have been many investigations with dogs in the detection of disease. In 2008 an investigation of György Horvath MD, oncologist of the Sahlgrenska Academy, University of Gothenburg, discovered the ability of dogs to detect ovarian cancer. Following these tests start an investigation along with professor Thomas Lindblad, of the Institute of technology KTH in Stockholm and the Jose Chilo researcher at the University of Gävle.

In November 2010 it was discovered that the blood of patients with ovarian cancer presents a same specific smell, this was made public in the journal BMC Cancer.

Horvath and the professors Thomas Lindbla and Jose Chilo got similar results to those obtained with the dogs in a second trial, in which an electronic was nose developed by Lindblad and Chilo, used to detect the odors of the cancer.

According to published the KTH, this electronic nose has a smell the fine enough to detect, in addition to cancer, the moment in which the grapes are ripe in the vines and already it can collect, the differences between pork and beef; the smell of explosives, drugs or rotten food or even, the time in which the content in an open bottle wine begins to be damaged.

Researchers say that this electronic nose is especially interesting because it produces better results than other similar technologies present in companies and universities.

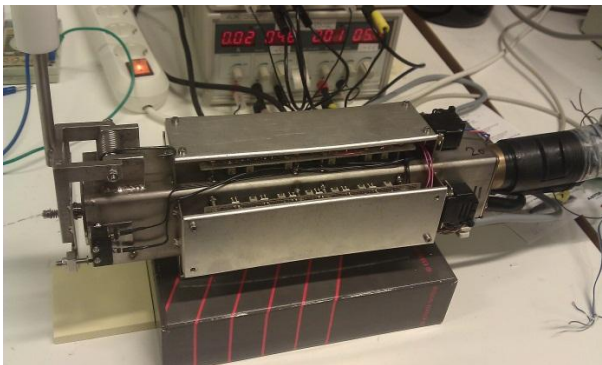

Fig 1: Prototype of the Jose Chilo electronic nose

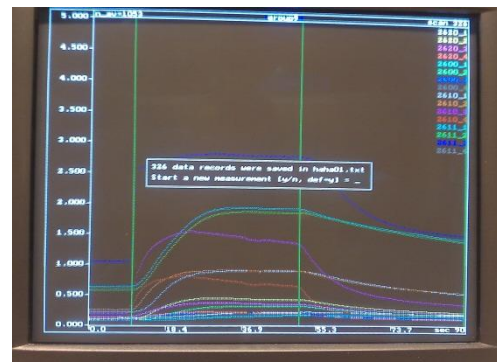

Fig. 2: Acquisition software

In regards to the detection of cancer, thanks to the accuracy of the device, scientists managed to make the distinction between healthy and diseased tissue samples in between 88 and 92 of the cases submitted.

According to the researchers, if bends the number of sensors that currently contains the electronic nose, this accuracy could reach 95.

The magazine Future Oncology, in which scientists have published the results of the tests carried out so far with the electronic nose, explains that many cancers are detected too late, resulting in a high mortality rate.

For that reason, it is crucial to develop simple and cheap methods of early diagnosis. The majority of ovarian tumors are benign, particularly in young women, but if they are malignant often be detected only when they are large enough to cause symptoms.

For this reason, ovarian cancer is detected often too late, with the consequent danger to the lives of those who suffer.

Our Project goals

The objective of this project is to create a prototype of electronic nose for the investigation of Jose Chilo, with 32 chemical sensors to increase the effectiveness of the previous model to a 95. The purpose of the prototype is measurements in different fields, not only of ovarian cancer, taking samples of substances for which were not designed specifically sensors. If you get an answer of some models of sensors to a stimulus, we create patterns for that substance and thus recognize it in future analyses.

Our design will be based on the previous model with 16 sensors. We will respect the basic circuit design of this model, but again redesign electronics, by adjusting the values of the components, creating a new design of the PCBs and the hardware on which the electronics will be assembled and will develop a new more powerful and flexible software.

Because the prototype does not have a commercial purpose, but research, will try to be more flexible, can configured all its characteristics depending on the measurement carried out.

HARDWARE

Sensors

For this work we use different models of biochemical sensors to the Figaro House.

The Designed device will be capable of working with various types of models of the family TGS 26xx, that share the same operating principle

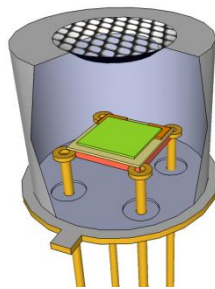

Fig. 3: Inside the sensor.

Operating principle of semiconductor type gas sensors

This operating principle applies to all TGS2xxx series sensors.

Fig. 1 shows basic gas sensor structure of TGS26xx series sensors as an example.

The gas sensor is composed of sensing element, sensor base and sensor cap. The sensing element contains sensing material and heater to heat up sensing element (eg. 400°C). Depending on the target gas, the sensing element will utilize different materials such as Tin dioxide (SnO_2), Tungsten oxide (WO_3), etc.

When a metal oxide crystal such as SnO_2 is heated at a certain high temperature in air, oxygen is adsorbed on the crystal surface with a negative charge. Then donor electrons in the crystal surface are transferred to the adsorbed oxygen, resulting in leaving positive charges in a space charge layer. Thus, surface potential is formed to serve as a potential barrier

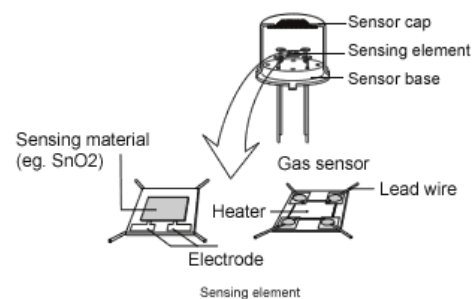
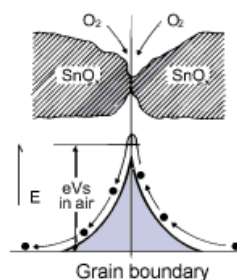

Fig. 1: Sensor structure



• Electron
eV: energy value of surface barrier

Fig. 2: Model of inter-grain potential barrier (in the absence of gases)

against electron flow (Figure 2).

Inside the sensor, electric current flows through the conjunction parts (grain boundary) of SnO₂ micro crystals. At grain boundaries, adsorbed oxygen forms a potential barrier which prevents carriers from moving freely. The electrical resistance of the sensor is attributed to this potential barrier.

In the presence of a deoxidizing gas, the surface density of the negatively charged oxygen decreases, so the barrier height in the grain boundary is reduced (Figures 3 and 4). The reduced barrier height decreases sensor resistance.

The relationship between sensor resistance and the concentration of deoxidizing gas can be expressed by the following equation over a certain range of gas concentration:

$$R_s = A[C]^{-\alpha}$$

Where:

R_s = electrical resistance of the sensor

A = constant

$[C]$ = gas concentration

α = slope of R_s curve

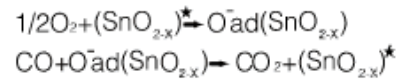

★ Free electron

Fig. 3: Scheme of the reaction between CO and adsorbed oxygen (O⁻ad) in the SnO₂ surface

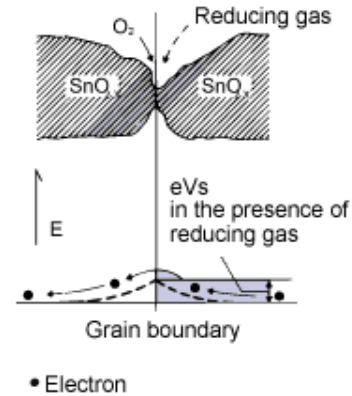









Fig. 4: Model of inter-grain potential barrier (in the presence of gases)

Used models

Although the device is able to work with any model of the TGS series 26xx have been selected following models to be installed in the nose:

Model	Target gas	Typical detection range	Ps	Description	Photo
TGS2442	Carbon monoxide	30 - 1,000ppm	14mW	Compact size Low sensitivity to alcohol vapor For residential CO detectors	
TGS2610-D00	LP gas	500 - 10,000ppm	280mW	High selectivity to LP gas Good durability For residential gas alarms	
TGS2610-C00	LP gas	500 - 10,000ppm	280mW	Quick gas response For leak checkers	
TGS2611-C00	Methane	500 - 10,000ppm	280mW	Quick gas response For leak checkers	
TGS2600	General air contaminants	1 - 30ppm	210mW	High sensitivity to air contaminants For indoor air quality control and automatic control in cooker hoods	
TGS2602	General air contaminants	1 - 30ppm	280mW	High sensitivity to VOCs and odorous gases For indoor air quality control	
TGS2620	Alcohol Solvent vapors	50 - 5,000ppm	210mW	Compact size For breath alcohol testers and solvent detectors	

TGS 2442

TGS 2442 utilizes a multilayer sensor structure. A glass layer for thermal insulation is printed between a ruthenium oxide (RuO₂) heater and an alumina substrate. A pair of Au electrodes for the heater is formed on a thermal insulator. The gas sensing layer, which is formed of tin dioxide (SnO₂), is printed on an electrical insulation layer which covers the heater. A pair of Au electrodes for measuring sensor resistance is formed on the electrical insulator. Activated charcoal is filled between the internal cover and the outer cover for the purpose of reducing the influence of noise gases.

TGS 2442 displays good selectivity to carbon monoxide, making it ideal for CO monitors. In the presence of CO, the sensor's conductivity increases depending on the gas concentration in the air. A simple pulsed electrical circuit operating on a signal which corresponds to gas concentration.

Specifications:

Model number		TGS 2442	
Sensing element type		M1	
Standard package		TO-5 metal can	
Target gases		Carbon monoxide	
Typical detection range		30~1000ppm	
Standard circuit conditions	Heater voltage cycle	V_H	$V_{HH}=4.8V\pm 0.2V$ DC, 14ms $V_{HL}=0.0$, 986ms
	Circuit voltage cycle	V_C	$V_C=0V$, for 995ms $V_C=5.0V\pm 0.2V$ DC, 5ms
	Load resistance	R_L	Variable ($\geq 10k\Omega$)
Electrical characteristics under standard test conditions	Heater resistance	R_H	$17\pm 2.5\Omega$ at room temp.
	Heater current	I_H	Approx.. 203mA (in case of V_{HH})
	Heater power consumption	P_H	Approx.. 14mW (ave.)
	Sensor resistance	R_S	13.3k Ω ~ 133k Ω in 100ppm of carbon monoxide
	Sensitivity (change ratio of R_S)	β	0.13~0.31
Standard test conditions	Test gas conditions		Carbon monoxide in air at $20\pm 2^\circ C$, $65\pm 5\%RH$
	Circuit conditions		Same as Std. Circuit Condition (above)
	Conditioning period before test		2 dys or more



Fig. 5: TGS 2442

TGS2610-D00/C00

TGS2610 is a semiconductor type gas sensor which combines very high sensitivity to LP gas with low power consumption and long life. Due to miniaturization of its sensing chip, TGS2610 requires a heater current of only 56mA and the device is housed in a standard TO-5 package. The TGS2610 is available in two different models which have different external housings but identical sensitivity to LP gas. Both models are able to satisfy the requirements of performance standards such as UL1484 and EN50194.

TGS2610-C00 possesses small size and quick gas response, making it suitable for gas leakage checkers.

TGS2610-D00 uses filter material in its housing which eliminates the influence of interference gases such as alcohol, resulting in highly selective response to LP gas. This feature makes the sensor ideal for residential gas leakage detectors which require durability and resistance against interference gas.

Specifications:

Model number		TGS 2610	
Sensing element type		D1	
Standard package		TO-5 metal can	
Target gases		Butane, LP gas	
Typical detection range		500~10,000ppm	
Standard circuit conditions	Heater voltage	V_H	5V±0.2V DC/AC
	Circuit voltage	V_C	5.0V±0.2V DC/AC
	Load resistance	R_L	Variable 0.45kΩ min
Electrical characteristics under standard test conditions	Heater resistance	R_H	Approx.. 59Ω at room temp.
	Heater current	I_H	56±5mA
	Heater power consumption	P_H	280mW
	Sensor resistance	R_S	0.68 ~ 6.8kΩ in 1800ppm of iso-butane
	Sensitivity (change ratio of R_S)		0.56±0.06 $\frac{R_S(3000ppm)}{R_S(1000ppm)}$
Standard test conditions	Test gas conditions	Iso-butane in air at 20±2°C, 65±5%RH	
	Circuit conditions	$V_C=5.0\pm0.01V$ DC $V_H=5.0\pm0.05V$ DC	
	Conditioning period before test	7 days	



Fig. 6: TGS 2610-D00



Fig. 7: TGS 2610-C00

TGS 2611-C00

TGS2611 is a semiconductor type gas sensor which combines very high sensitivity to methane gas with low power consumption and long life. Due to miniaturization of its sensing chip, TGS2611 requires a heater current of only 56mA and the device is housed in a standard TO-5 package.

The **TGS2611** is available in two different models which have different external housings but identical sensitivity to methane gas. Both models are able to satisfy the requirements of performance standards such as UL1484 and EN50194.

TGS2611-C00 possesses small size and quick gas response, making it suitable for gas leakage checkers.

TGS2611-E00 uses filter material in its housing which eliminates the influence of interference gases such as alcohol, resulting in highly selective response to methane gas. This feature makes the sensor ideal for residential gas leakage detectors which require durability and resistance against interference gas.

Specifications:

Model number		TGS 2611	
Sensing element type		D1	
Standard package		TO-5 metal can	
Target gases		Methane, Natural Gas	
Typical detection range		500~10,000ppm	
Standard circuit conditions	Heater voltage	V_H	5V±0.2V DC/AC
	Circuit voltage	V_C	5.0V±0.2V DC $P_s \leq 15\text{mW}$
	Load resistance	R_L	Variable 0.45kΩ min
Electrical characteristics under standard test conditions	Heater resistance	R_H	59Ω at room temp. (typical)
	Heater current	I_H	56±5mA
	Heater power consumption	P_H	280±25mW
	Sensor resistance	R_S	0.68 ~ 6.8kΩ in 5000ppm methane
	Sensitivity (change ratio of R_S)		0.60±0.06 $\frac{R_S(9000\text{ppm})}{R_S(3000\text{ppm})}$
Standard test conditions	Test gas conditions	Methane in air at 20±2°C, 65±5%RH	
	Circuit conditions	$V_C=5.0\pm 0.01\text{V DC}$ $V_H=5.0\pm 0.05\text{V DC}$	
	Conditioning period before test	7 days	



Fig. 8: TGS 2611

TGS 2600

The sensing element is comprised of a metal oxide semiconductor layer formed on an alumina substrate of a sensing chip together with an integrated heater. In the presence of a detectable gas, the sensor's conductivity increases depending on the gas concentration in the air. A simple electrical circuit can convert the change in conductivity to an output signal which corresponds to the gas concentration.

The **TGS2600** has high sensitivity to low concentrations of gaseous air contaminants such as hydrogen and carbon monoxide which exist in cigarette smoke. The sensor can detect hydrogen at a level of several ppm. Figaro also offers a microprocessor (FIC02667) which contains special software for handling the sensor's signal for appliance control applications.

Due to miniaturization of the sensing chip, **TGS2600** requires a heater current of only 42mA and the device is housed in a standard TO-5 package.

Specifications:

Model number		TGS 2600	
Sensing element type		D1	
Standard package		TO-5 metal can	
Target gases		Air contaminants	
Typical detection range		1~30ppm of H ₂	
Standard circuit conditions	Heater voltage	V _H	5V±0.2V DC/AC
	Circuit voltage	V _C	5.0V±0.2V DC P _s ≤15mW
	Load resistance	R _L	Variable 0.45kΩ min
Electrical characteristics under standard test conditions	Heater resistance	R _H	Approx.. 83Ω at room temp. (typical)
	Heater current	I _H	42±4mA
	Heater power consumption	P _H	210mW V _H =5.0V DC
	Sensor resistance	R _S	10k ~ 90kΩ in air
	Sensitivity (change ratio of R _s)		0.3~0.6 $\frac{R_s (10ppm\ of\ H_2)}{R_s (air)}$
Standard test conditions	Test gas conditions	Normal air at 20±2°C, 65±5%RH	
	Circuit conditions	V _C =5.0±0.01V DC V _H =5.0±0.05V DC	
	Conditioning period before test	7 days	



Fig. 9: TGS 2600

TGS 2602

The sensing element is comprised of a metal oxide semiconductor layer formed on the alumina substrate of a sensing chip together with an integrated heater. In the presence of detectable gas, sensor conductivity increases depending on gas concentration in the air. A simple electrical circuit can convert the change in conductivity to an output signal which corresponds to the gas concentration.

The **TGS2602** has high sensitivity to low concentrations of odorous gases such as ammonia and H₂S generated from waste materials in office and home environments. The sensor also has high sensitivity to low concentrations of VOCs such as toluene emitted from wood finishing and construction products. Figaro also offers a microprocessor (FIC02667) which contains special soft-ware for handling the sensor's signal for appliance control applications.

Due to miniaturization of the sensing chip, **TGS2602** requires a heater current of only 42mA and the device is housed in a standard TO-5 package.

Specifications:

Model number		TGS 2602	
Sensing element type		D1	
Standard package		TO-5 metal can	
Target gases		Air contaminants	
Typical detection range		1~30ppm of EtOH	
Standard circuit conditions	Heater voltage	V _H	5V±0.2V DC/AC
	Circuit voltage	V _C	5.0V±0.2V DC P _s ≤15mW
	Load resistance	R _L	Variable 0.45kΩ min
Electrical characteristics under standard test conditions	Heater resistance	R _H	Approx.. 59Ω at room temp.
	Heater current	I _H	56±5mA
	Heater power consumption	P _H	280mW (typical)
	Sensor resistance	R _S	10k ~ 100kΩ in air
	Sensitivity (change ratio of R _s)		0.15~0.5 $\frac{R_s (10ppm \text{ of EtOH})}{R_s (air)}$
Standard test conditions	Test gas conditions	Normal air at 20±2°C, 65±5%RH	
	Circuit conditions	V _C =5.0±0.01V DC V _H =5.0±0.05V DC	
	Conditioning period before test	7 days	



Fig. 10: TGS 2602

TGS 2620

The sensing element is comprised of a metal oxide semiconductor layer formed on an alumina substrate of a sensing chip together with an integrated heater. In the presence of a detectable gas, the sensor's conductivity increases depending on the gas concentration in the air. A simple electrical circuit can convert the change in conductivity to an output signal which corresponds to the gas concentration.

The **TGS2620** has high sensitivity to the vapors of organic solvents as well as other volatile vapors. It also has sensitivity to a variety of combustible gases such as carbon monoxide, making it a good general purpose sensor.

Due to miniaturization of the sensing chip, **TGS2620** requires a heater current of only 42mA and the device is housed in a standard TO-5 package.

Specifications:

Model number		TGS 2620	
Sensing element type		D1	
Standard package		TO-5 metal can	
Target gases		Alcohol, solvent vapors	
Typical detection range		50~5000ppm	
Standard circuit conditions	Heater voltage	V_H	5V±0.2V DC/AC
	Circuit voltage	V_C	5.0V±0.2V DC/AC $P_s \leq 15mW$
	Load resistance	R_L	Variable 0.45kΩ min
Electrical characteristics under standard test conditions	Heater resistance	R_H	83Ω at room temp. (typical)
	Heater current	I_H	42±4mA
	Heater power consumption	P_H	Approx.. 210mW
	Sensor resistance	R_S	1 ~ 5kΩ in 300ppm ethanol
	Sensitivity (change ratio of R_S)		0.3~0.5 $\frac{R_S(300ppm)}{R_S(50ppm)}$
Standard test conditions	Test gas conditions	Ethanol vapor in air at 20±2°C, 65±5%RH	
	Circuit conditions	$V_C=5.0\pm0.01V$ DC $V_H=5.0\pm0.05V$ DC	
	Conditioning period before test	7 days	



Fig. 11: 2620

Measuring circuit

TGS2442: Basic Measuring Circuit.

Circuit voltage (V_C) is applied across the sensing element which has a resistance (R_S) between the sensor's two electrodes (pins No. 2 and No. 3) and a load resistor (R_L) connected in series. The sensing element is heated by the heater which is connected to pins No. 1 and No. 4.

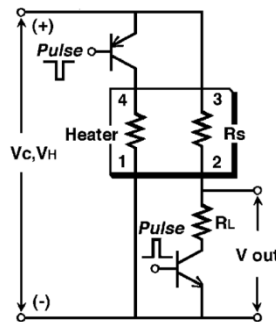

Fig. 15: Basic measuring circuit (TGF2442).

Heating cycle: The sensor requires application of a 1 second heating cycle which is used in connection with a circuit voltage cycle of 1 second. Each V_H cycle is comprised by 4.8 V being applied to the heater for the first 14ms, followed by 0V pulse for the remaining 986ms. The V_C cycle consists of 0V applied for 995ms, followed by 5.0V for 5ms. For achieving optimal sensing characteristics, the sensor's signal should be measured after the midpoint of the 5ms V_C pulse of 5.0V.

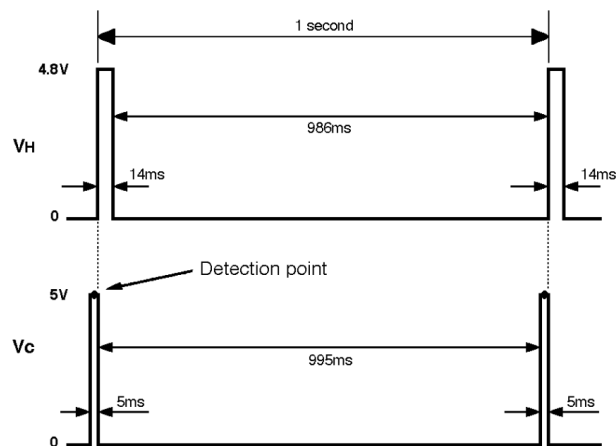

Fig. 16: Circuit voltage and heater voltage cycles.

Basic Measuring Circuit (TGS2600/TGS2602/TGS2620/TGS2610/TGS2611):

The sensor requires two voltage inputs: heater voltage (V_H) and circuit voltage (V_C). The heater voltage (V_H) is applied to the integrated heater in order to maintain the sensing element at a specific temperature which is optimal for sensing. Circuit voltage (V_C) is applied to allow measurement of voltage (V_{RL}) across a load resistor (R_L) which is connected in series with the sensor. A common power supply circuit can be used for both V_C and V_H to fulfill the sensor's electrical requirements. The value of the load resistor (R_L) should be chosen to optimize the alarm threshold value, keeping power consumption (P_S) of the semiconductor below a limit of 15mW. Power consumption (P_S) will be highest when the value of R_S is equal to R_L on exposure to gas.

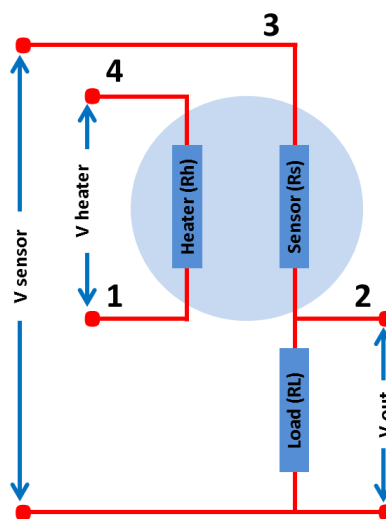

Fig. 17: Basic measuring circuit.

Sensor Preheating

Sensor preheating: The minimum period for sensor preheating is 2 days, but for best results, 7 days or longer preheating is strongly advised.

Preheating of final assembly: The minimum period for preheating final assemblies would be 2 hours, but for best results it is strongly recommended that 1 day or more preheating be done.

Be sure to adhere to standard circuit conditions and maintain clean atmospheric conditions when preheating.

Heater voltage dependency

TGS sensors are designed to show optimum sensitivity characteristics under a certain constant heater voltage. The figure in down shows a typical example of how gas sensitivity varies depending on heater voltage. Since the sensor has a heater voltage dependency, a constant regulated heater voltage must be supplied to the sensor according to specifications.

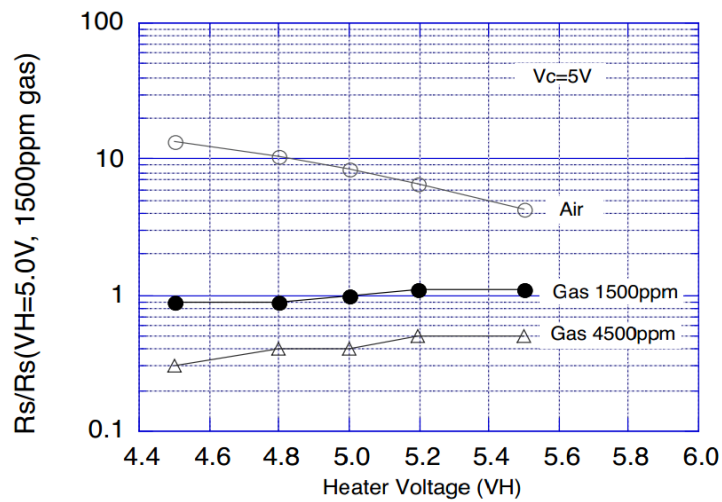

Fig. 18: Typical heater voltage dependency

Socket sensors

SR-6: Is a reliable and durable socket supplied by Figaro, designed specifically for usage with TGS24xx and 26xx series sensors.



Fig. 19: Socket sensor.

The Sensor Circuit

The following figure shows the circuit we have done to make the part of sensors in our circuits.

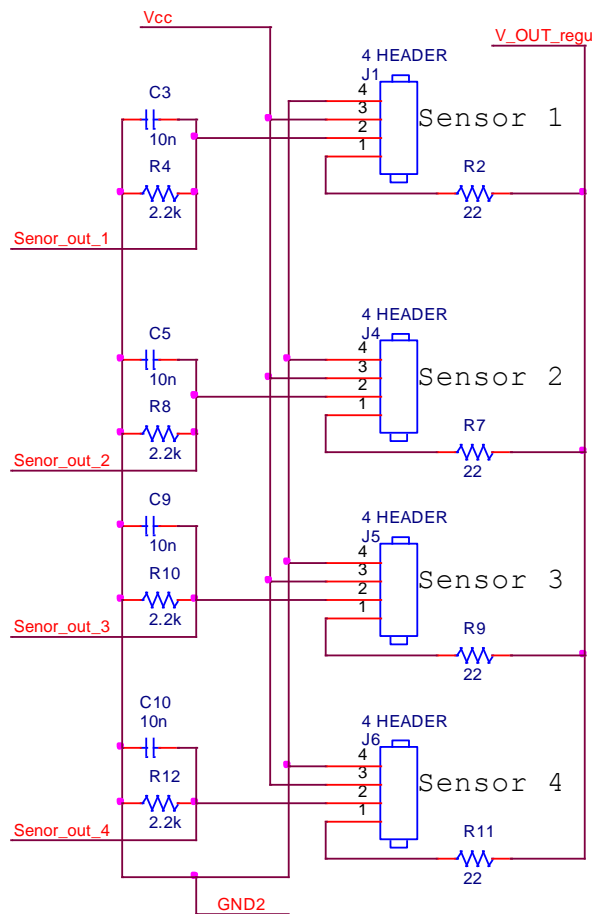

Fig. 20: The sensor circuit.

Regulator



Fig. 21: The regulator pins

Pin	Description
V _{IN}	This is the input supply voltage to the regulator.
GND	Circuit ground for the regulator.
V _{OUT}	Regulated output voltage.
V _{EN}	The enable pin allows the part to be turned ON and OFF by pulling this pin high or low.
ADJ	The adjust pin is used to set the regulated output voltage by connecting it to the external resistors R1 and R2.

Output Capacitor

An output capacitor is required for loop stability. It must be located less than 1 centimeter from the device and connected directly to the output and ground pins using traces which have no other currents flowing through them. The minimum amount of output capacitance that can be used for stable operation is 1 μ F. Ceramic capacitors are recommended (the LP38690/2-ADJ was designed for use with ultra-low ESR capacitors). The LP38690/2-ADJ is stable with any output capacitor ESR between zero and 100 Ohms.

Setting The Output Voltage

The output voltage is set using the external resistors R1 and R2. The output voltage will be given by the equation:

$$V_{OUT} = V_{ADJ} \times (1 + R1/R2)$$

Because the part has a minimum load current requirement of 100 μ A, it is recommended that R2 always be 12k Ohms or less to provide adequate loading. Even if a minimum load is always provided by other means, it is not recommended that very high value resistors be used for R1 and R2 because it can make the ADJ node

susceptible to noise pickup. A maximum value of 100k is recommended for R2 to prevent this from occurring.

Enable Pin

The LP38692–ADJ has an Enable pin (EN) which allows an external control signal to turn the regulator output On and Off. The Enable On/Off threshold has no hysteresis. The voltage signal must rise and fall cleanly, and promptly, through the ON and OFF voltage thresholds. The Enable pin has no internal pull-up or pull-down to establish a default condition and, as a result, this pin must be terminated either actively or passively. If the Enable pin is driven from a source that actively pulls high and low, the drive voltage should not be allowed to go below ground potential or higher than VIN. If the application does not require the Enable function, the pin should be connected directly to the VIN pin.

Regulator Circuit

The following figure shows the circuit we have done to make the part of the regulator in our circuits.

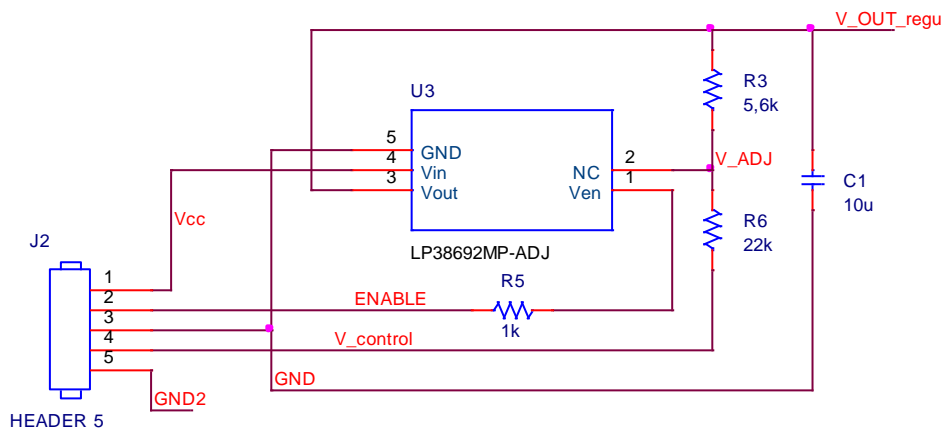

Fig. 22: Regulator circuit

Operational

At the beginning we had intended to put the operational TL074 but so we changed the OP400 because it works better, since the sensors when they are at rest take a voltage lower than the minimum threshold (on the 1.5V) you need this amp to function as a follower amplifier.

As the amplifier TL074 did not reach the minimum threshold. The TL074 amplifier not behaved as a voltage follower and their outputs earned an 8V voltage value.

To replace it with the OP400 amplifier, the already reached the minimum threshold and behaved as a voltage follower.

OP 400

General Description

The OP400 is the first monolithic quad operation al amplifier that features OP77 -type performance. Precision performance is not sacrificed with the OP400 to obtain the space and cost savings offered by quad amplifiers. The OP400 features an extremely low input offset voltage of less than $150\mu\text{V}$ with a drift of less than $1.2\mu\text{V}/^\circ\text{C}$, guaranteed over the full military temperature range. Open-loop gain of the OP400 is more than 5 million into a $10\text{ k}\Omega$ load, input bias current is less than 3 nA , CMR is more than 120 dB , and PSRR is less than $1.8\mu\text{V}/\text{V}$. On-chip Zener zap trimming is used to achieve the low input offset voltage of the OP400 and eliminates the need for offset nulling. The OP400 conforms to the industry-standard quad pin out, which does not have null terminals.

The OP400 features low power consumption, drawing less than $725\mu\text{A}$ per amplifier. The total current drawn by this quad amplifier is less than that of a single OP07, yet the OP400 offers significant improvements over this industry-standard op amp. Voltage noise density of the OP400 is a low $11\text{ nV}/\sqrt{\text{Hz}}$ at 10 Hz , half that of most competitive devices. The OP400 is an ideal choice for applications requiring multiple precision operational amplifiers and where power consumption low is critical.

Operational Circuit

The following figure shows the circuit we have done to make the part of the operational OP400 in our circuits.

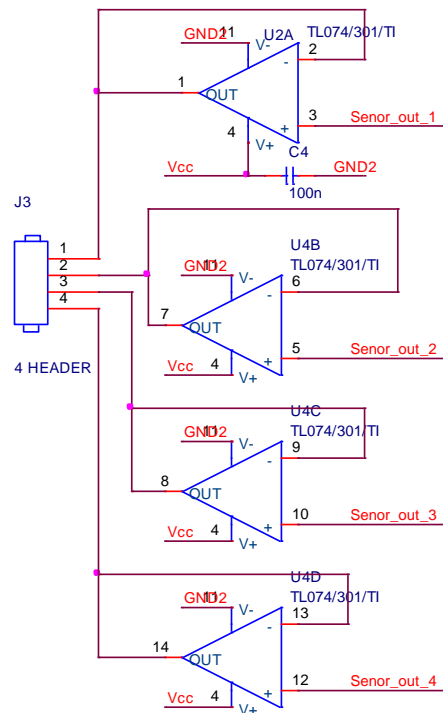

Fig. 23: Operational Circuit.

Design of PCB

We have made a small design, because if the plates are great, it would touch each other and could not put it well.

Each plate has 4 sensors. The sensors are spaced equidistant, even from a plate to plate. There are two levels of mass, to eliminate or reduce the interference that might be. The plates are powered at 9 volts.

Top layer and Bottom layer

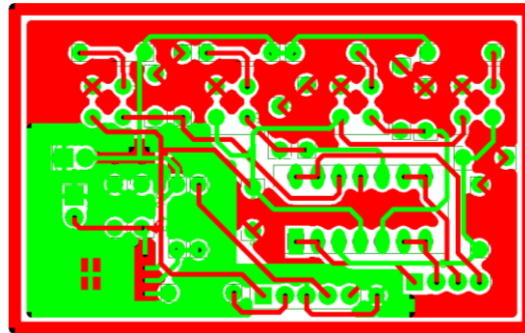

Fig. 24: Top layer and Bottom layer.

Top Layer

In the figure below we have the top layer of the plate. The level of mass, only have the voltage regulator circuit.

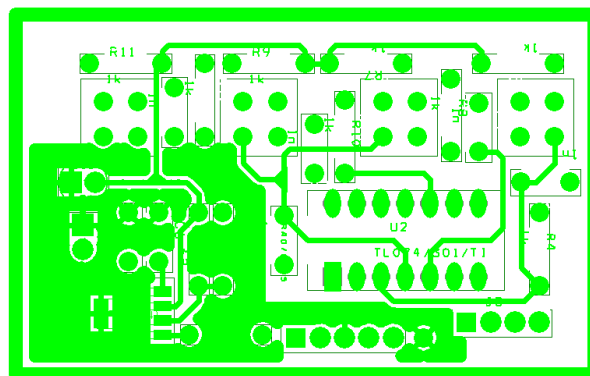

Fig. 25: Top layer.

Bottom layer

In the figure below we have the bottom layer of the plate. The level of mass, this by the plaque.

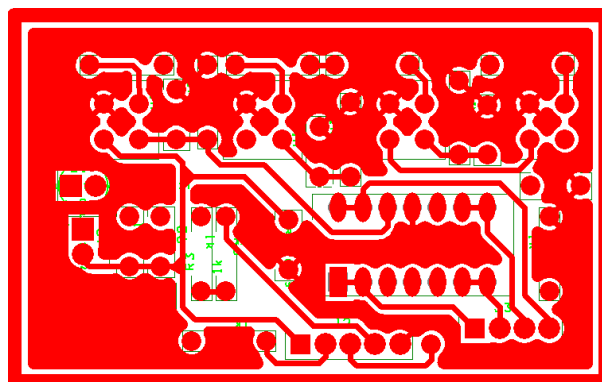

Fig. 26: Bottom layer.

Power supply

We use the FAC-662B source since it provides us with a single feed and a current of 2A or more.



Fig. 27: FAC-662B

Specifications	
Variable outputs	
Independent mode	0 to 30V / 0 to 1A
Parallel mode	0 to 30V / 0 to 2A
Series mode	0 to 60V / 0 to 1A
Tracking mode	0 to $\pm 30V$ / 0 to 1A
Internal resistance	
	6m Ω (1kHz)
	10m Ω (1kHz)
Load regulation	
Constant voltage	$\leq 1.5\text{mV}$
Constant current	$\leq 3\text{mA}$
Mains regulation	
Constant voltage	$\leq 1\text{mV}$
Constant current	$\leq 2\text{mA}$
Noise and hum	
Constant voltage	$\leq 500\mu\text{Vrms}$
Measuring instruments	
	Digital, V y A
Accuracy	$\pm(0.1\% \text{ Reading} \pm 1 \text{ digit})$
Voltmeter resolution	100mV
Ammeter resolution	10mA
Thermal protection	
Output V/A	5V / 2A
Power supply	
Mains voltage	110-125-220-24- V AC / 50-60 Hz
Consumption	145W
Mechanical features	
Dimensions (mm)	210 x 185 x 280
Weight	6.6 kg

Steel piece

We use a piece of stainless steel with reference 316LN, in which any kind of smell does not adhere to metal.



Fig. 28: Vertical steel piece



Fig. 29: Horizontal steel piece

Air injection system

Air pump

We use a PARI BOY N air pump, provided by the hospital Gandia, that they made a project with this air pump.



Fig. 30: PARI BOY N

Aerosol characteristics

	Total Output	MMD (mass median diameter)	Mass fraction of less than 5 μ m
PARI BOY N <small>Note 1)</small>	470 mg/min	3,7 μ m	64%

Measurement using the Malvern Mastersizer X at 23 ° C and 50% relative humidity.

Note 1) inspiratory flow 20 l / min

Electrovalve

We use the S070C DG - 5 Body ported.



Fig. XX: *Body ported*
(A)

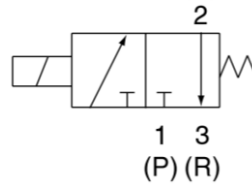

Fig. 31: *JIS Symbol*

Specifications	
Valve construction	Poppet
Fluid	Air/Inert gas/Low vacuum (1.33×10^2 Pa)
Maximum operating pressure	0.3MPa (0.35 W, 0.1 W), 0.5MPa (0.5W)
Proof pressure	1MPa
Ambient and fluid temperature ^{Note 1)}	-10 to 50°C
Lubrication	Not required
Impact/Vibration resistance ^{Note 2)}	30/150 m/s ²
Enclosure	IP40
Weight	5g (Single unit valve)
Mounting orientation	Free

Note 1) Use dry air and prevent condensation at low temperatures.

Note 2) Vibration resistance: No malfunction resulted in 45 to 2000Hz, a one-sweep test performed in the axial and right angle directions of the main valve and armature for both energized and de-energized states.

Impact resistance: No malfunction resulted in an impact test using a drop impact tester. The test was performed one time each in the axial and right angle directions of the main valve and armature, for both energized and de-energized states.

With the 0.1W specification, the vibration and impact resistance is 10/50 m/s² or less.

Note 3) With the low vacuum specification, the operating pressure range is 1.33×10^2 Pa to the maximum operating pressure.

Solenoid Specifications	
Power consumption ^{Note 1)}	0.35W (Standard), 0.5W (High voltage), 0.1W (Holding)
Rated coil voltage	3, 5, 6, 12, 24 VDC
Allowable voltage fluctuation ^{Note2)}	±10% of the rated voltage
Coil insulation type	Equivalent to class B

Note 1) With a light/surge voltage suppressor and power saving circuit, the light consumes a power equivalent to 2mA.

Note 2) With a power saving circuit, keep the voltage fluctuation within 24 VDC ±5%

Flow Specifications/Response Time						
Power Consumption	Maximum operating pressure	Flow characteristics			Response time ms ^{Note 2)}	
		C[dm ³ /(s.bar)]	b	Cv	ON	OFF
0.5W DC	0.5MPa	0.042	0.27	0.011	3 or less	3 or less
	0.3MPa	0.083	0.28	0.021	5 or less	3 or less
0.35W DC	0.3MPa	0.042	0.27	0.011	3 or less	3 or less
	0.1MPa	0.083	0.28	0.021	5 or less	3 or less
0.1W DC (at holding) with power saving circuit ^{Note1)}	0.3MPa	0.021	0.27	0.006	3 or less	6 or less
	0.1MPa	0.042	0.28	0.011	5 or less	6 or less

Note 1) With the 0.1W DC specification, keep the vibration/impact within 10/50 m/s².

Note 2) The response time is the value at the rated voltage and maximum operating pressure.

Circuit in order to use the electrovalve

Below this the circuit that we used to be able to control the solenoid valve from the LabView program.

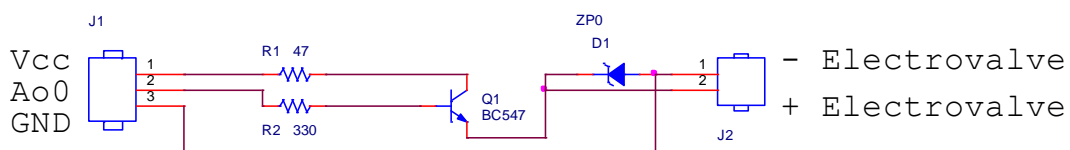

Fig. 32: Circuit to use the electrovalve.

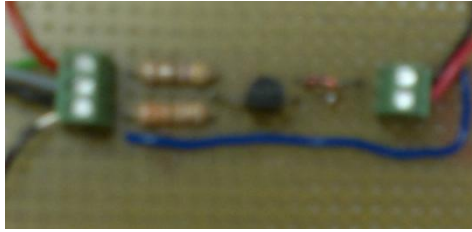

Fig. 33: Real montage of the circuit.

Components used for the circuit

Transistor BC547C:

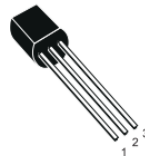

Fig. 34: Transistor BC547C

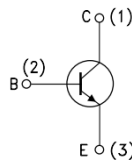

Fig. 35: Internal schematic diagram.

Absolute Maximum Ratings			
Symbol	Parameter	Value	Unit
V_{CBO}	Collector-Base Voltage ($I_E = 0$)	50	V
V_{CEO}	Collector-Emitter Voltage ($I_B = 0$)	45	V
V_{EBO}	Emitter-Base Voltage ($I_C = 0$)	6	V
I_C	Collector Current	100	mA
I_{CM}	Collector Peak Current	200	mA
P_{tot}	Total Dissipation at $T_C = 25\text{ }^\circ\text{C}$	500	mW
T_{stg}	Storage Temperature	-65 to 150	$^\circ\text{C}$
T_j	Max. Operating Junction Temperature	150	$^\circ\text{C}$

Diode Zener - 1N5231B:

Fig. 36: Diode zener - 1N5231B.

Primary Characteristics		
Parameter	Value	Unit
V_Z range nom.	2.4 to 75	V
Test current I_{ZT}	1.7 to 20	mA
V_Z specification	Thermal equilibrium	
Int. construction	Single	

Absolute Maximum Ratings ($T_{amb} = 25^\circ\text{C}$, unless otherwise specified)				
Parameter	Test condition	Symbol	Value	Unit
Power dissipation	$T_L \leq 25^\circ\text{C}$	P_{tot}	500	mW
Zener current		I_Z	P_{tot}/V_Z	mA
Thermal resistance junction to ambient air	$l = 4\text{mm}$, $T_L = \text{constant}$	R_{thJA}	300	K/W
Junction temperature		T_j	175	$^\circ\text{C}$
Storage temperature range		T_{stg}	-65 to +175	$^\circ\text{C}$
Forward voltage (max)	$I_F = 200\text{mA}$	V_F	1.1	V

Acquisition Board: NI USB-6218

The NI USB-6218 is a bus-powered isolated USB M Series multifunction data acquisition (DAQ) module optimized for superior accuracy at fast sampling rates. It offers 32 analog inputs; 250kS/s single-channel sampling rate; two analog outputs; eight digital input lines; eight digital output lines; four programmable input ranges (± 0.2 to $\pm 10V$) per channel; digital triggering; and two counter/timers. For improved accuracy and safety, 60V, CAT I isolation is provided.

The USB-6218 is designed specifically for mobile or space-constrained applications. Plug-and-play installation minimizes configuration and setup time, while direct screw-terminal connectivity keeps costs down and simplifies signal connections. Because this module is bus-powered from USB, you can discard unnecessary external power supplies.

The USB-6218 also features NI signal streaming technology, which gives you DMA-like bidirectional high-speed streaming of data across USB. For more information about NI signal streaming, view the Resources tab.



Fig. 37: NI USB-6218

Specifications:

Analog Output	
Channels	2
Resolution	16 bits
Max Voltage	10 V
Maximum Voltage Range	-10 V , 10 V
Maximum Voltage Range Accuracy	3.512mV
Minimum Voltage Range	-10 V , 10 V
Minimum Voltage Range Accuracy	3.512mV
Update Rate	250kS/s
Current Drive Single	2mA
Current Drive All	4mA

Analog Input	
Channels	32 , 16
Single-Ended Channels	32
Differential Channels	16
Resolution	16 bits
Sample Rate	250kS/s
Max Voltage	10 V
Maximum Voltage Range	-10 V , 10 V
Maximum Voltage Range Accuracy	2.69mV
Maximum Voltage Range Sensitivity	91.6 μ V
Minimum Voltage Range	-200mV , 200mV
Minimum Voltage Range Accuracy	0.088mV
Minimum Voltage Range Sensitivity	4.8 μ V
Number of Ranges	4
Simultaneous Sampling	No
On-Board Memory	4095 samples

Connection with the acquisition card NI USB-6218:

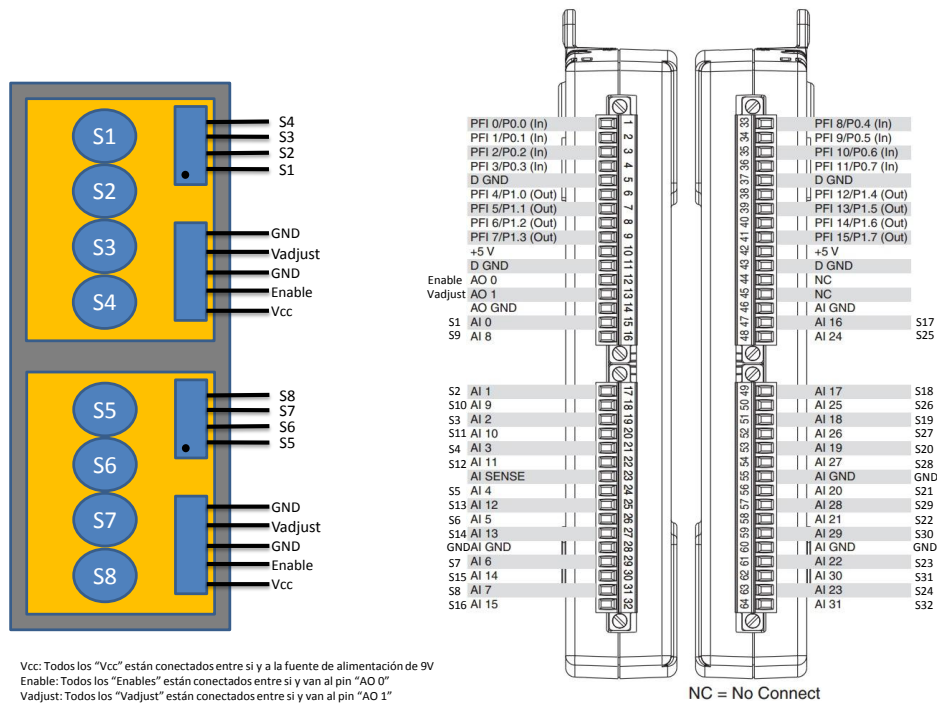

Fig. 38: Connecting the acquisition card with the electronic nose

Final assembly

We have 8 equal plates. Plates place them the piece of steel and connect each output of the sensors to the data acquisition card. Also connect the air injection system. And the result is the following, which everything works correctly.

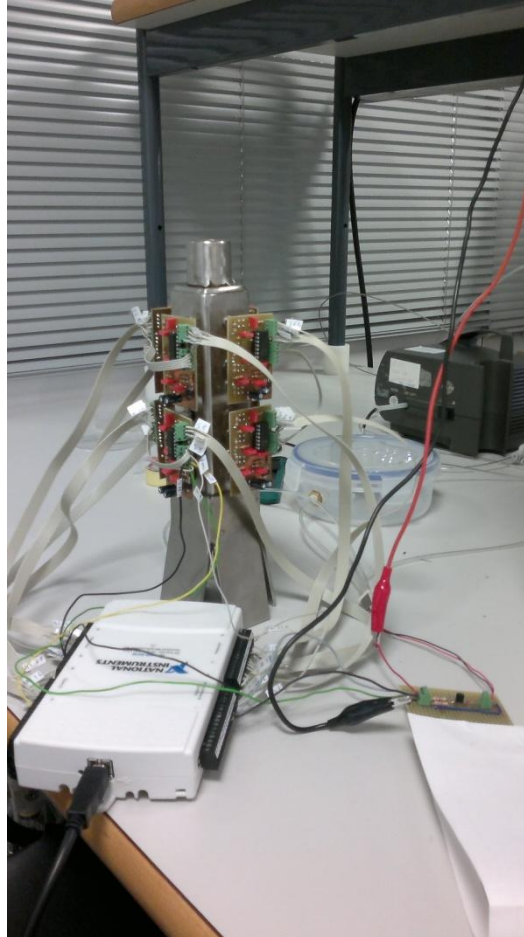

Fig. 39: Multi-sensor olfactory system full

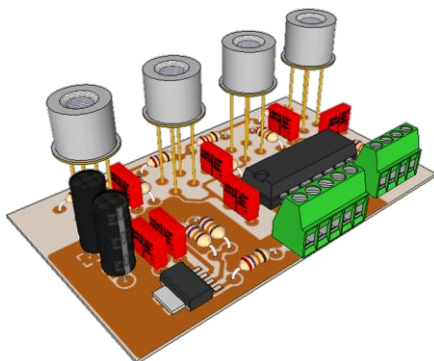

Fig. 40: 3D simulation of the board

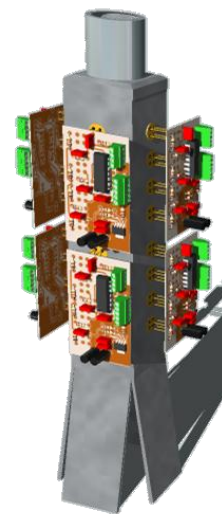

Fig. 41: 3D simulation of the e-nose

FUTURE IMPROVEMENTS

As I said, to be resistive sensors, we should supply it in current to obtain more stable measurements. This could be done with a sensor signal conditioning circuit using a generalized impedance converter (GIC). The circuit is dc polarized and able to feed a constant current to one or more sensors. GIC input impedance is kept high to maintain the load current of its input reference voltage very low.

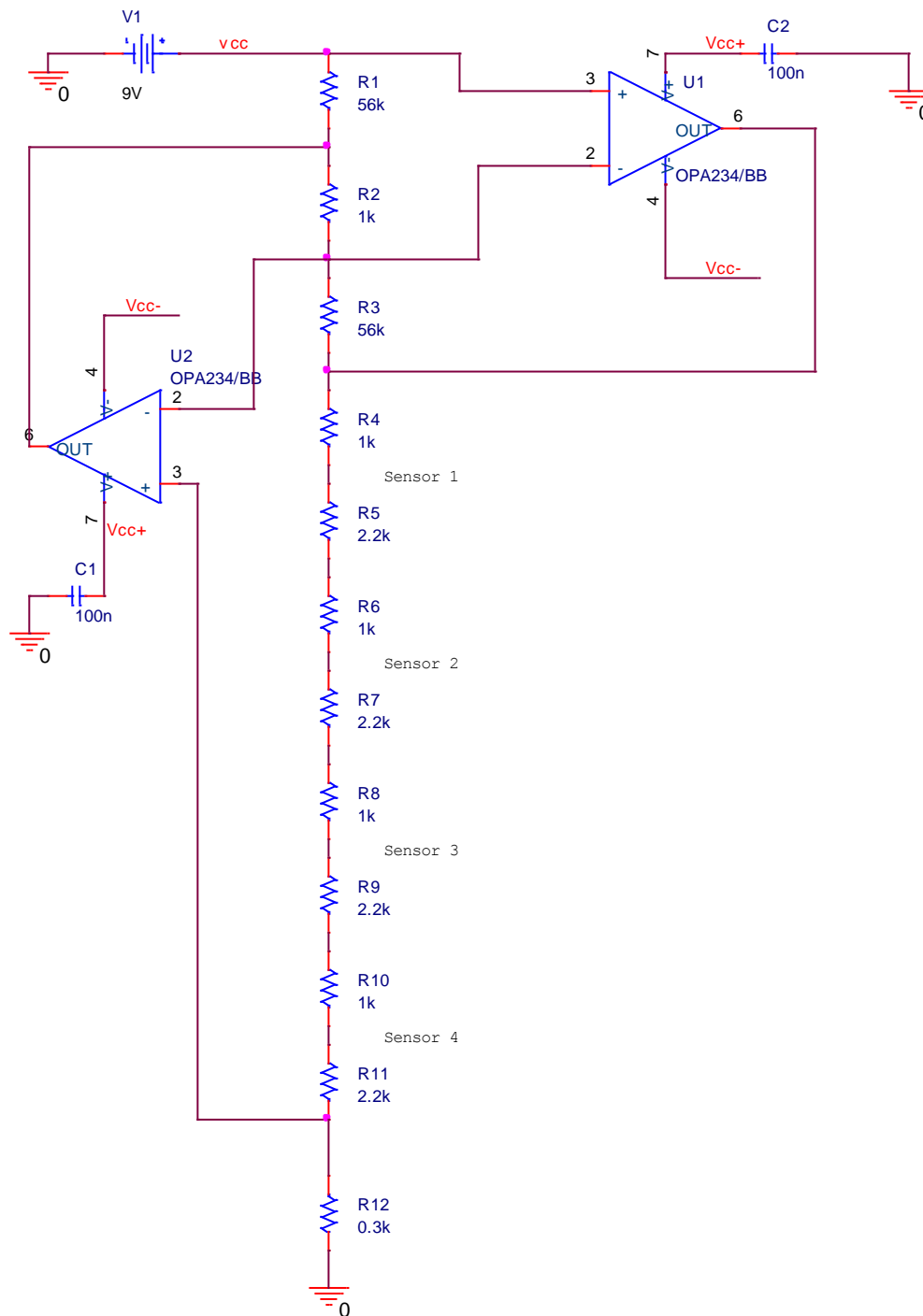

Fig. 42: GIC scheme

In terms of design hardware would propose that the boards were of eight sensors instead of four, this form would save connections and simplify the design. In addition the mounted system requires a complex and confusing connection system. Connectors type DIP simplification mounting the device, giving greater reliability connections.

In an ideal design would include a microprocessor that managed the acquisition of data from the sensors, avoiding the use of the acquisition board and the wiring of the 32 outputs of sensors. Moreover the conditioning step, which is now limited to a follower of tension, should be an adjustable or programmable gain amplifier to obtain a maximum resolution in any type of measure.

Finally I updated the design to a new measurement system based on a current-supply 4 sensors wheatstone bridge. Bridge two of the sensors would be exposed to the substance to be measured as they are on the current device, while others found always exposed to clean air. In this way it would not be necessary to use load resistance, making a differential measure in the bridge and avoiding as well calibration of sensors. In addition we would get compensation in temperature, humidity and any substance that is in the middle, and can only measure the substance desired with great accuracy.

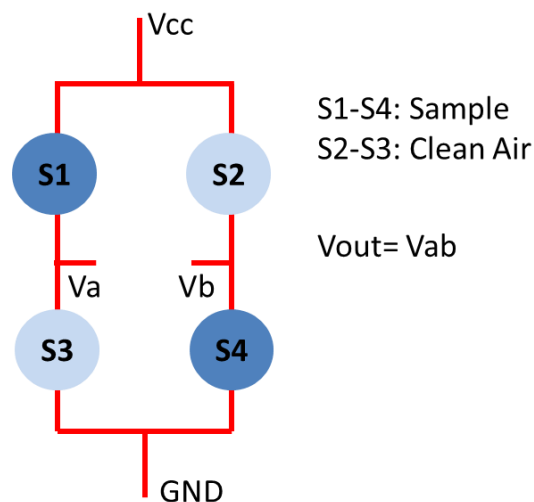

Fig. 4312: Wheatstone bridge scheme

Thanks to the structure of this design, the obtained resolution would be double, with which the system would gain a number of new features that would make it far superior to the current. A new metal support for this design and a greater use of resources would be necessary as they are required 4 sensors for each sample.

To improve the Assembly that we have done, and the wiring should be reduced. A way to reduce the wiring would be making only 4 plates (one on each side of the steel tube) rather than 8, so would wiring plate to plate on each side be eliminated since it would go by the own plate.

The system also would improve a little, since the difference is not much, if in each sensor to take the value of its proper load for each sensor resistance, because they are all different, even if they are of the same type of sensor.

With regard to the software, it would include new analytical tools embedded in the program that is not necessary the use of Matlab or external programs to extract patterns or any other type of information.

CONCLUSION

The device has been improved, incorporating double sensors, control over heater supply and improving the electronic design. The developed software is powerful and flexible to adjust to the needs of any measure.

I also made the characterization of all the models used, extracting information about its optimal point of work.

The realization of this project has also been a step towards a new prototype more advanced, leaving exposed the shortcomings of this design and the future improvements that we can implement.

The project has been presented at the I2MTC 2012 IEEE Congress on 14 May in Austria, which is an award for the work done.

The realization of the project, would have been better starting with the characterization of each sensor and adapt each sensor as required.

We had a couple of problems when it comes to the plates, by the type of chemical material that we used to reveal the plates since we were not accustomed to such material and therefore didn't know it well as I worked with him.

BIBLIOGRAPHY

Figaro. (s.f.). *Figaro Sensors*. <http://www.figarosensor.com/>

György Horvath, J. C. (2010). Different volatile signals emitted by human ovarian carcinoma and healthy tissue. *Future Oncology* (6), 1043

Hovarth, G. (s.f.). *Biomedical central*. Characteristic odour in the blood reveals ovarian carcinoma: <http://www.biomedcentral.com/1471-2407/10/643>

Instruments, N. (s.f.). *LabVIEW System Design Software*. <http://www.ni.com/labview/>

J. Chilo, L. H. (s.f.). *Future Medicine*. Different volatile signals emitted by human ovarian carcinoma and healthy tissue: <http://www.futuremedicine.com/doi/abs/10.2217/fon.10.60>

J. Pelegri, R. L. (2011). *LabView: Entorno gráfico de programación*. Barcelona: Ed. Marcombo.

Pari. (s.f.). *Pari Respiratory Equipment*. <http://www.pari.de/>

R. Pallás-Areny, J. W. (1991). *Sensors and signal conditioning*. New York: Ed. John Wiley.

SMC. (s.f.). *SMC Worldwide leading experts in pneumatics*. <http://www.smc.eu>