



UNIVERSITAT
POLITÈCNICA
DE VALÈNCIA

ESCOLA TÈCNICA SUPERIOR
D'ENGINYERIA AGRONÒMICA I
DEL MEDI NATURAL

TESIS DOCTORAL

**Biology, epidemiology and control of
Fusicladium eriobotryae, causal agent of loquat scab**

Elisa González Domínguez

Directores:

Josep Armengol Fortí

Mónica Berbegal Martínez

Valencia, Mayo de 2014

Este trabajo ha sido realizado en el Grupo de Investigaciones en Hongos Fitopatógenos del Instituto Agroforestal Mediterráneo (Universit  Politecnica de Val ncia) y en el Istituto di Entomologia e Patologia vegetale de la Universit  Cattolica del Sacro Cuore, Piacenza, Italia (estancia financiada por el Programa de Apoyo a la Investigaci n y Desarrollo, PAID-00-12, de la Universidad Polit cnica de Valencia), gracias a la concesi n de una Beca de Formaci n de Personal Investigador de la Universit  Politecnica de Val ncia (FPI-UPV) y ha sido financiado por la Cooperativa Agr cola de Callosa d'En Sarri  (Alicante).

Agradecimientos

Gracias a Josep Armengol por su enorme dedicación a esta tesis, por su apoyo constante, y por su gran paciencia en muchas ocasiones. Por involucrarse de una forma tan cercana y por enseñarme tantas cosas durante todo este tiempo. A Mónica Berbegal, por todos los buenos consejos que he recibido, por apoyar cada iniciativa y por ser un punto de referencia constante. A José García, por su esfuerzo para que esta tesis pudiera llevarse a cabo, por su enorme aportación y, sobre todo, por transmitirme su visión de la patología vegetal y del objetivo de nuestro trabajo, que espero no olvidar nunca.

Gracias a los agricultores de la Cooperativa Agrícola de Callosa d'En Sarrià y en especial a su técnico, Esteban Soler, por la confianza depositada en nuestro grupo de investigación, apoyando económicamente este estudio e interesándose constantemente por los resultados. A Alfonso y Juanjo, por su gran ayuda en las evaluaciones de campo. Gracias en especial a Esteban por transmitirme su entusiasmo por el cultivo del níspero.

Gracias a Vittorio Rossi, por todo lo que he aprendido durante mis estancias en la Università Cattolica del Sacro Cuore de Piacenza (Italia). Gracias por ayudarnos de una forma tan generosa, y por todo el trabajo realizado en tres de los artículos que conforman esta tesis. A Sami Michereff por los buenos consejos en los estudios de campo y por preocuparse en mantener la colaboración a pesar de la gran distancia. A Ricardo Brainer y Emerson Del Ponte por colaborar en uno de los capítulos de la tesis.

Gracias a Maela por toda su ayuda en los estudios moleculares desarrollados en esta tesis y por todo lo que me ha enseñado en estos años. A José Manuel Rodríguez por colaborar tan intensamente en uno de los capítulos. A Valentín y a Toni por su colaboración en el trabajo de laboratorio, y por su buen humor constante. Gracias a todos los compañeros que hacen del laboratorio un lugar mucho más divertido a pesar de las largas jornadas. Gracias a Carlos, Bea, Paloma, Ana, David, Santi, y Alex. A los alumnos de intercambio con los que he coincidido (especialmente Ibtissem y Kamila), que vinieron a aprender y nos enseñaron muchas cosas. Gracias al grupo de virus (especialmente Ana e Isabel) por su buen humor y su interés en el desarrollo de la tesis.

Gracias a los alumnos que, con sus Trabajos Finales de Carrera, han colaborado en la realización de los experimentos que conforman esta tesis. A Alejandro Martorell, Andreu Miñana, Josep Borrás, Paloma Quintanilla, Marc Mahiques, Ana Guillem y Marta Calatayud.

Gracias a Sara, Tito y Giuseppe, por toda su ayuda y gran acogida durante mi estancia en Piacenza, y especialmente a Esther, que por sorpresa se convirtió en una gran compañía durante esa estancia.

Gracias a mis padres, José María y Elisa, y a mi hermano Julio por acoger con ilusión cada nueva aventura en esta carrera (de obstáculos) científica. A Pere por atreverse a acompañarme en la próxima. Gracias a todos los amigos que me han acompañado durante estos casi cinco años en Valencia. Gracias especialmente a ese universo paralelo de la Alquería, por recordarme cada día, las (otras) cosas importantes.

Summary

Scab, caused by *Fusicladium eriobotryae*, is the main disease affecting loquat in Spain and other countries in the Mediterranean basin. This fungus attacks young twigs, leaves and fruits, causing circular olive-colored spots. Scabby fruits are unsuitable for the market, resulting in significant economic losses. *Fusicladium* spp. are the anamorphic stages of the ascomycete genus *Venturia*, but the sexual stage of *F. eriobotryae* has never been found in nature. This genus includes important scab pathogens, such as *Venturia inaequalis* on apple, *V. pyrina* on pear or *Fusicladium oleagineum* on olive.

Although loquat is an important source of income in the main Spanish cultivation areas, *F. eriobotryae* has received little attention by plant pathologists and farmers have been aimed to manage loquat scab according to the information available for apple scab. In this scenario, years with favorable environmental conditions for the disease result in severe economic losses. Therefore, an improvement in the knowledge of loquat scab is needed and has been addressed globally in this thesis with the overall aim of developing specific tools to manage the disease.

First of all, the effect of environmental factors on mycelial growth, conidial germination and the infection of loquat leaves by *F. eriobotryae* was studied, and equations describing these processes were developed. Mycelium of *F. eriobotryae* was able to grow and conidia to germinate in a wide range of temperatures (5-25°C), although more conidia germinated and the mycelium grew faster between 15 and 25°C. Substantial germination of *F. eriobotryae* conidia occurred only after 12 h of wetness and its viability was reduced by dry periods. Infection of loquat leaves by *F. eriobotryae* occurred between 10 and 20°C and with at least 12 h of continuous wetness.

In addition, dispersal of conidia of *F. eriobotryae* was investigated in two loquat orchards in Spain during two growing seasons. *F. eriobotryae* conidia were collected between March and May and 90% of them during rainy periods. Based on ROC and Bayesian analysis, using ≥ 0.2 mm rainfall as a cut-off value resulted in a high probability of correctly predicting actual conidial dispersal, with a low probability of failing. Based on the index of dispersion and the binary power law, the incidence of loquat scab on fruit was highly aggregated in space between and within trees, and aggregation was influenced by disease incidence. The results demonstrated that *F. eriobotryae* is dispersed mainly in rain splash.

The results obtained in the previous research were used to develop a mechanistic, dynamic model to predict infection of loquat fruit by conidia of *F. eriobotryae*. The model simulates scab infection periods and their severity through the sub-processes of spore dispersal, infection, and latency. Change from one state to the following one depends on environmental conditions and on

processes described by mathematical equations. The model was validated by comparing model output with three independent data sets. The model accurately predicts the occurrence and severity of infection periods as well as the progress of loquat scab incidence on fruit (with concordance correlation coefficients >0.95). Moreover, model output agreed with expert assessment of the disease severity in seven loquat-growing seasons.

As a tool for model evaluation, and for further assessments of loquat scab severity, a standard area diagram set (SADs) was developed. The SADs consists of eight black and white images exhibited the typical symptom patterns of loquat scab on fruits. The SADs improve the accuracy and reliability of the estimates by inexperienced rather than experienced raters.

Another valuable tool developed was a nested-PCR protocol for *F. eriobotryae* identification from pure culture or infected loquat tissues. A specific primer was designed in the EF1- α gen, which combined with the universal one EF1-986R, was able to differentiate *F. eriobotryae* from other pathogens belonging to the genus *Venturia* and from fungal species commonly present in loquat tissues. This protocol can be useful for routine diagnosis, disease monitoring programs and epidemiological research.

One of the goals of this thesis was to evaluate the efficacy of the main fungicide classes against *F. eriobotryae*. Thirteen fungicides were evaluated *in vitro* by testing their effect on mycelial growth and conidial germination. The results showed that the fungicides currently recommended in Spain by the regional plant health services against loquat scab are able to reduce both, mycelial growth and conidial germination. Additionally, a growth chamber experiment was conducted to determine the pre- and post-infection activity of five selected fungicides. Difenoconazole and pyraclostrobin applications resulted in relative disease severity (RDS) values lower than 5%, even when applied 7 days before or after inoculation, whereas boscalid and mancozeb showed good pre-infection activity.

Finally, *F. eriobotryae* resistance to the site-specific fungicides difenoconazole (DMI) and thiophanate-methyl (MBC) was determined by inhibition of mycelial growth on fungicide-amended media. To this aim, 249 *F. eriobotryae* isolates were collected from the main loquat production provinces of Spain (Alicante, Almería, Castellón, Granada, and Valencia). A wide distribution of *F. eriobotryae* isolates resistant to difenoconazole, present in 4 out of the 5 provinces surveyed, was found, while isolates resistant to thiophanate-methyl were present only in Alicante province. In this province, almost 15% of the isolates were resistant to this fungicide and *F. eriobotryae* isolates with difenoconazole/thiophanate-methyl multiple resistances were also detected.

Isolates resistant to thiophanate-methyl were molecular characterized by sequencing of the MBC-target encoding the β -tubulin gene. Results showed that all of the *F. eriobotryae* isolates resistant to thiophanate-methyl contained one of the aminoacid substitutions E198K, F200Y or L240F.

Resumen

El moteado del níspero, causado por el hongo *Fusicladium eriobotryae*, es la principal enfermedad que afecta a este cultivo en España y otros países de la cuenca Mediterránea. Este hongo ataca brotes jóvenes, hojas y frutos, produciendo manchas circulares de color verde-oliváceo. Los frutos con síntomas de moteado no se pueden comercializar, lo que supone importantes pérdidas económicas. Las especies pertenecientes al género *Fusicladium* son estados anamórficos del género *Venturia*, pero en el caso de *F. eriobotryae*, su fase sexual nunca se ha encontrado. El género *Venturia* incluye importantes patógenos causantes de moteado en otros cultivos, como *V. inaequalis* en manzano, *V. pyrina* en peral ó *F. oleagineum* en olivo.

Aunque en la principal zona de producción de níspero en España su cultivo es una importante fuente de ingresos, hasta la fecha *F. eriobotryae* ha recibido poca atención por parte de investigadores. De hecho, las recomendaciones a los agricultores para el manejo de la enfermedad se han realizado en función de la información existente para el moteado del manzano. En este contexto, los años con condiciones favorables para el desarrollo de la enfermedad dan lugar a importantes pérdidas económicas. Por tanto, se requiere una mejora en el conocimiento del moteado del níspero, que ha sido abordada de forma global en esta tesis, con el objetivo de desarrollar herramientas específicas para el manejo de la enfermedad.

En primer lugar, se estudió el efecto de diversos factores ambientales sobre el crecimiento de *F. eriobotryae*, la germinación de sus conidios y la infección de las hojas de níspero, desarrollando ecuaciones matemáticas capaces de describir estos procesos. El micelio de *F. eriobotryae* fue capaz de crecer y los conidios de germinar en un amplio rango de temperaturas (5-25°C), aunque los mayores porcentajes de germinación y el crecimiento más rápido del micelio ocurrió a temperaturas comprendidas entre 15 y 25°C. Fue necesario un mínimo de 12 horas de humectación para la germinación de un porcentaje apreciable de conidios de *F. eriobotryae* y su viabilidad se vio reducida por la presencia de períodos secos (sin agua libre). La infección de hojas de níspero por *F. eriobotryae* ocurrió entre 10 y 20°C y con, al menos, 12 horas de humectación continua.

Además, se realizó un seguimiento de la dispersión de los conidios de *F. eriobotryae* en dos parcelas de níspero situadas en Callosa d'En Sarrià (Alicante), durante dos ciclos de cultivo. Los conidios de *F. eriobotryae* se capturaron principalmente entre Marzo y Mayo, y el 90% de ellos durante períodos con lluvia. El estudio de la lluvia como predictor de las capturas se realizó mediante análisis de curvas ROC y análisis Bayesianos. Considerando 0,2 mm de lluvia como valor de corte, se obtuvo una alta probabilidad de predecir correctamente la dispersión de los conidios de *F. eriobotryae*. Basándose en el índice de dispersión y la ley de potencia binaria, la incidencia del moteado del níspero se mostró altamente agregada, tanto entre árboles como dentro de ellos, viéndose el grado de agregación influenciado por el valor de la incidencia de la enfermedad. Los resultados obtenidos demuestran que *F. eriobotryae* se dispersa principalmente asociado a las gotas de lluvia.

Estos resultados fueron utilizados para desarrollar un modelo dinámico y mecanicístico, capaz de predecir la infección de frutos de níspero por conidios de *F. erobotryae*. El modelo simula los períodos de infección del moteado del níspero y su severidad a través de los sub-procesos de dispersión, infección y latencia. Los cambios de un estado a otro dependen de factores ambientales descritos por ecuaciones matemáticas. El modelo fue validado comparándolo con tres grupos diferentes de datos. El modelo predijo de forma precisa la ocurrencia y severidad de los períodos de infección, así como el progreso de la enfermedad en los frutos (con coeficientes de correlación >0.95). Además, los resultados del modelo estuvieron de acuerdo con la valoración que un experto dio de la severidad de la enfermedad durante siete campañas de cultivo.

Como una herramienta complementaria para la evaluación del modelo y también para futuras mediciones de la severidad del moteado del níspero, se desarrolló una escala diagramática de la enfermedad. Este diagrama consistió en 8 imágenes en blanco y negro con los síntomas típicos de la enfermedad sobre los frutos. Además, se comprobó cómo la escala mejora la precisión de las estimaciones hechas por evaluadores no experimentados.

Otra herramienta de utilidad desarrollada en esta tesis ha sido un protocolo de nested-PCR para la identificación de *F. erobotryae* a partir de cultivos puros del hongo o de tejidos de níspero infectados. Para ello, se diseñó un primer específico en el gen EF1- α que, combinado con el universal EF1-986R, fue capaz de diferenciar *F. erobotryae* de otros patógenos pertenecientes al género *Venturia* y de otras especies fúngicas habitualmente presentes en tejidos de níspero. Este protocolo puede ser útil para diagnósticos rutinarios, programas de monitoreo de la enfermedad e investigaciones epidemiológicas.

Uno de los objetivos de esta tesis fue evaluar la eficacia de los principales grupos de fungicidas frente a *F. erobotryae*. Trece fungicidas fueron estudiados *in vitro*, determinando tanto su efecto sobre el crecimiento micelial como en la germinación de los conidios del patógeno. Los resultados mostraron que los fungicidas actualmente recomendados en España por los servicios de sanidad vegetal son capaces de reducir tanto el crecimiento micelial como la germinación de los conidios. Además, se llevó a cabo un experimento en cámara de cultivo para determinar el efecto en pre- y post-infección de cinco materias activas seleccionadas. Las plantas tratadas con difenoconazol o piraclostrobin presentaron valores de severidad relativa al control no inoculado inferiores al 5%, incluso cuando los fungicidas fueron aplicados 7 días antes o después de la inoculación. Sin embargo, boscalida y mancozeb mostraron únicamente buena actividad cuando fueron aplicados antes de la infección.

Finalmente, se determinó la resistencia de *F. erobotryae* a los fungicidas sistémicos difenoconazol y metil-tiofanato, mediante la inhibición del crecimiento micelial del hongo en medio de cultivo toxicado con cada uno de los fungicidas. Para ello, se recogieron 249 aislados de *F. erobotryae* en las principales provincias productoras de níspero (Alicante, Almería, Castellón, Granada, y Valencia). Los aislados de *F. erobotryae* resistentes a difenoconazol se encontraron ampliamente distribuidos, detectándose en 4 de las 5 provincias

muestreadas, mientras que sólo se encontraron aislados resistentes a metil-tiofanato en la provincia de Alicante. En esta provincia, casi el 15% de los aislados fueron resistentes a este fungicida, y también se detectaron aislados con resistencia múltiple a difenoconazol y metil-tiofanato. Los aislados resistentes a metil-tiofanato fueron caracterizados molecularmente mediante la secuenciación del gen de la β -tubulina. Los resultados mostraron que todos los aislados de *F. erobotryae* resistentes al metil-tiofanato contenían una de las sustituciones aminoacídicas E198K, F200Y o L240F.

El motejat de la nespra, causat pel fong *Fusicladium eriobotryae*, és la principal malaltia que afecta aquest cultiu a Espanya i altres països de la conca Mediterrània. Aquest fong ataca brots joves, fulles i fruits, produint taques circulars de color verd-olivaci. Els fruits amb símptomes de motejat no es poden comercialitzar, el que suposa importants pèrdues econòmiques. Les espècies pertanyents al gènere *Fusicladium* són estats anamòrfics del gènere *Venturia*, però en el cas de *F. eriobotryae*, la fase sexual mai s'ha trobat. El gènere *Venturia* inclou importants patògens causants de motejat en altres cultius, com *V. inaequalis* en pomera, *V. pyrina* en perera o *F. oleagineum* en olivera.

Encara que en la zona de producció de nespra a Espanya el seu cultiu és una important font d'ingressos, fins a la data *F. eriobotryae* ha rebut poca atenció per part d'investigadors. De fet, les recomanacions als agricultors per al maneig de la malaltia s'han realitzat en funció de la informació existent per al motejat de la pomera. En aquest context, els anys amb condicions favorables per al desenvolupament de la malaltia donen lloc a importants pèrdues econòmiques. Per tant, es requereix una millora en el coneixement del motejat de la nespra, que ha estat abordada de forma global en aquesta tesi, amb l'objectiu de desenvolupar eines específiques per al maneig de la malaltia.

En primer lloc, es va estudiar l'efecte de diversos factors ambientals sobre el creixement de *F. eriobotryae*, la germinació dels seus conidis i la infecció de les fulles de nespra, desenvolupant equacions matemàtiques capaços de descriure aquests processos. El miceli de *F. eriobotryae* va ser capaç de créixer i els conidis de germinar en un ampli rang de temperatures (5-25 ° C), tot i que els majors percentatges de germinació i el creixement més ràpid del miceli varen ocórrer a temperatures compreses entre 15 i 25 ° C. Va ser necessari un mínim de 12 hores d'humectació per a la germinació d'un percentatge apreciable de conidis de *F. eriobotryae* i la seva viabilitat es va veure reduïda per la presència de períodes secs (sense aigua lliure). La infecció de fulles de nespra per *F. eriobotryae* va ocórrer entre 10 i 20 ° C i amb, almenys, 12 hores d'humectació contínua.

A més, es va realitzar un seguiment de la dispersió dels conidis de *F. eriobotryae* en dues parcel·les de nespra situades a Callosa d'En Sarrià (Alacant), durant dos cicles de cultiu. Els conidis de *F. eriobotryae* es van capturar principalment entre Març i Maig, i el 90% d'ells durant períodes amb pluja. L'estudi de la pluja per a predir les captures es va realitzar mitjançant anàlisi de corbes ROC i anàlisis Bayesians. Considerant 0,2 mm de pluja com a valor de tall, es va obtenir una alta probabilitat de predir correctament la dispersió dels conidis de *F. eriobotryae*. Basant-se en l'índex de dispersió i la llei de potència binària, la incidència del motejat de la nespra es va mostrar altament agregada, tant entre arbres com dins d'ells, trobant-se el grau d'agregació influenciat pel valor de la incidència de la malaltia. Els resultats obtinguts demostren que *F. eriobotryae* es dispersa principalment associat a les gotes de pluja.

Aquests resultats van ser utilitzats per desenvolupar un model dinàmic i mecanicista, capaç de predir la infecció de fruits de nespra per conidis de *F.*

eriobotryae. El model simula els períodes d'infecció del motejat de la nespra i la seva severitat a través dels sub-processos de dispersió, infecció i latència. Els canvis d'un estat a un altre depenen de factors ambientals descrits per equacions matemàtiques. El model va ser validat comparant amb tres grups diferents de dades. El model va predir de manera precisa l'ocurrència i severitat dels períodes d'infecció, així com el progrés de la malaltia en els fruits (amb coeficients de correlació > 0.95). A més, els resultats del model van estar d'acord amb la valoració que un expert va donar de la severitat de la malaltia durant set campanyes de cultiu.

Com una eina complementària per a l'avaluació del model i també per a futures mesures de la severitat del motejat de la nespra, es va desenvolupar una escala diagramàtica de la malaltia. Aquest diagrama inclou 8 imatges en blanc i negre amb els símptomes típics de la malaltia sobre els fruits. A més, es va comprovar com l'escala millora la precisió de les estimacions fetes per avaluadors no experimentats.

Una altra eina d'utilitat desenvolupada en aquesta tesi ha estat un protocol de nested-PCR per a la identificació de *F. eriobotryae* a partir de cultius purs del fong o de teixits de nespra infectats. Per a això, es va dissenyar un primer específic en el gen EF1- α que, combinat amb l'universal EF1-986R, va ser capaç de diferenciar *F. eriobotryae* d'altres patògens pertanyents al gènere *Venturia* i d'altres espècies fúngiques habitualment presents en teixits de nespra. Aquest protocol pot ser útil per a diagnòstics rutinaris, programes de seguiment de la malaltia i investigacions epidemiològiques.

Un dels objectius d'aquesta tesi va ser avaluar l'eficàcia dels principals grups de fungicides enfront de *F. eriobotryae*. Tretze fungicides van ser estudiats in vitro, determinant tant el seu efecte sobre el creixement micelià com en la germinació dels conidis del patogen. Els resultats van mostrar que els fungicides actualment recomanats a Espanya pels serveis de sanitat vegetal són capaços de reduir tant el creixement micelià com la germinació dels conidis. A més, es va dur a terme un experiment en cambra de cultiu per determinar l'efecte en pre- i post-infecció de cinc matèries actives seleccionades. Les plantes tractades amb difenoconazol o piraclostrobina van presentar valors de severitat relativa al control no inoculat inferiors al 5%, fins i tot quan els fungicides van ser aplicats 7 dies abans o després de la inoculació. No obstant això, boscalid i mancozeb van mostrar únicament bona activitat quan van ser aplicats abans de la infecció.

Finalment, es va determinar la resistència de *F. eriobotryae* als fungicides sistèmics difenoconazol i metil-tiofanato, mitjançant la inhibició del creixement micelià del fong en medi de cultiu toxicat amb cadascun dels fungicides. Per a això, es van recollir 249 aïllats de *F. eriobotryae* a les principals províncies productores de nespra (Alacant, Almeria, Castelló, Granada, i València). Els aïllats de *F. eriobotryae* resistents a difenoconazol es van trobar àmpliament distribuïts, detectant en 4 de les 5 províncies mostrejades, mentre que només es van trobar aïllats resistents a metil-tiofanato a la província d'Alacant. En aquesta província, gairebé el 15% dels aïllats van ser resistents a aquest fungicida, i també es van detectar aïllats amb resistència múltiple a

difenoconazol i metil-tiofanato. Els aïllats resistents a metil-tiofanato van ser caracteritzats molecularment mitjançant la seqüenciació del gen de la β -tubulina. Els resultats van mostrar que tots els aïllats de *F. erobotryae* resistents al metil-tiofanato contenien una de les substitucions aminoacídiques E198K, F200Y o L240F.

Content Index

Table index	xv
Figure index.....	xvii
Chapter 1. General Introduction	3
Loquat cultivation	3
Loquat scab caused by <i>Fusicladium eriobotryae</i>	6
Chapter 2. Objectives	15
Chapter 3. Effect of environmental factors on mycelial growth and conidial germination of <i>Fusicladium eriobotryae</i> , and the infection of loquat leaves	19
Chapter 4. Dispersal of conidia of <i>Fusicladium eriobotryae</i> and spatial patterns of scab in loquat orchards in Spain	41
Chapter 5. Development and validation of a standard area diagram set to aid assessment of severity of loquat scab on fruit	63
Chapter 6. Development and validation of a weather-based model for predicting infection of loquat fruit by <i>Fusicladium eriobotryae</i>	79
Chapter 7. A nested-polymerase chain reaction protocol for in planta detection of <i>Fusicladium eriobotryae</i> , causal agent of loquat scab	105
Chapter 8. Evaluation of fungicides to control loquat scab caused by <i>Fusicladium eriobotryae</i>	115
Chapter 9. Identification of resistance to difenoconazole and thiophanate-methyl in field populations of <i>Fusicladium eriobotryae</i> , and molecular characterization of thiophanate-methyl resistant isolates	125
Chapter 10. General discussion	139
Chapter 11. Conclusions.....	147
References	151

Table Index

Table 1.1. Loquat world production	4
Table 1.2. Diseases affecting loquat	7
Table 1.3. Fungicide schedule recommended for the management of loquat scab in Alicante province (Spain) (GVA, 2013)	12
Table 3.1. Equations used to fit data on mycelial growth (1), conidial germination (2), effect of dry period on conidial germination (3), disease incidence (4) and severity (5) of <i>Fusicladium eriobotryae</i> as a function of environmental variables	28
Table 3.2. Parameter estimates and summary statistics of nonlinear regression analysis relating the relative growth of <i>Fusicladium eriobotryae</i> at different temperatures	29
Table 4.1. Collection of conidia of <i>Fusicladium eriobotryae</i> on vertical and horizontal microscope slides in relation to rainfall events during the sampling periods in two loquat orchards (A and B) in Alicante, Spain, in 2011 and 2012.	48
Table 4.2. Evaluation of rainfall to predict collection of <i>Fusicladium eriobotryae</i> on slides placed under loquat trees in orchards A and B in Alicante, Spain, in 2011 and 2012	52
Table 5.1. Effect of use of SADs as an assessment aid on the bias, precision and overall agreement of estimates of scab severity on loquat fruit made by raters with or without experience in disease severity assessment.....	71
Table 5.2. Effect of rater experience on the bias, precision and overall agreement of estimates of scab severity on loquat fruit made by ten raters either unaided or aided by a standard area diagram (SAD).....	72
Table 5.3. Inter-rater reliability (reproducibility) of visual estimates of scab severity on 50 loquat fruit by 20 raters either unaided (one-time assessment) or aided by SADs measured by the intra-class correlation coefficient (ICC). Two assessments were made using the SADs with a two-week interval	74
Table 5.4. Intra-rater reliability (repeatability), measured by Lin's concordance correlation coefficient (ρ_c), for estimates of severity on 50 diseased loquat fruit by two groups of ten raters either with or without experience but using SADs during two consecutive SAD-aided assessments	74

Table 6.1. List of variables used in the model	85
Table 6.2. Statistics and indices used for evaluating the goodness-of-fit of loquat scab infection predicted by the model versus disease observed in field.....	95
Table 7.1. List of <i>Fusicladium eriobotryae</i> isolates and other fungi used to determine specificity of the species-specific primer	107
Table 7.2. Detection of <i>Fusicladium eriobotryae</i> in samples from loquat trees using either single or nested PCR assays.....	111
Table 8.1. Fungicides selected for in vitro sensitivity testing	117
Table 8.2. EC50 values for inhibiting in vitro mycelial growth and conidial germination of <i>Fusicladium eriobotryae</i> by fungicides representing different chemical classes.....	120
Table 9.1. Characteristics of <i>Fusicladium eriobotryae</i> isolates selected for molecular characterization of thiophanate-methyl resistance	129
Table 9.2. Primers used in the molecular characterization of <i>Fusicladium eriobotryae</i> to thiophanate-methyl	132

Figure Index

Figure 1.1. A, young loquat twig affected by scab; B, first symptoms of scab (circular chlorotic spots) in a loquat leaf; C, conidia of *Fusicladium eriobotryae* arising from the cracked cuticle of a loquat leaf; D, loquat fruit showing initial scab lesions (olive colored and velvety); E, stroma producing conidia in a loquat leaf; F, fruit showing several lesions that coalesce; G, loquat leaf severely affected by scab; H, fruit severely affected by scab with old (brown, corky) and young (olivaceous) lesions; I, loquat tree severely affected by scab

Figure 3.1. Relationship between temperature and relative growth of *Fusicladium eriobotryae* mycelium as predicted by Equation 1 of Table 3.1. Symbols represent observed data and whiskers are the standard errors calculated over different experiments and fungal isolates. Relative growth is calculated by dividing growth (mm/day) in each observation by the maximum growth at optimum temperature 26

Figure 3.2. Relationship between temperature, wetness duration and relative germination of conidia of *Fusicladium eriobotryae* as predicted by Equation 2 of Table 3.1. Relative conidial germination is calculated by dividing percentage of germinated conidia in each observation by the maximum germination found in each experiment 27

Figure 3.3. Predicted versus observed data on relative germination of *Fusicladium eriobotryae* conidia. Data are predicted by Equation 2 of Table 3.1. Whiskers are the standard errors calculated over different experiments and fungal isolates..... 27

Figure 3.4. Relationship between length of dry periods and relative germination of *Fusicladium eriobotryae* conidia as predicted by Equation 3 of Table 3.1. Symbols represent observed data and whiskers are the standard errors calculated over different experiments and fungal isolates. Relative conidial germination is calculated by dividing percentage of germinated conidia in each observation by the maximum germination found in each experiment..... 30

Figure 3.5. Effect of temperature and wetness duration on scab incidence (A) and severity (B) in loquat leaves inoculated with *Fusicladium eriobotryae*. Each column represents the mean disease incidence of two experiments with five replicate plants each. Incidence was assessed as the percentage of leaves with scab lesions per plant and severity as the percentage of leaf area with scab lesions. Whiskers represent the standard errors..... 33

Figure 3.6. Relationship between temperature, wetness duration and relative scab incidence of *Fusicladium eriobotryae* on loquat leaves as predicted by Equation 4 of Table 3.1. Relative disease incidence is calculated by dividing incidence for each plant by the maximum incidence found in the experiment 34

Figure 3.7. Relationship between temperature, wetness duration and relative scab severity of *Fusicladium eriobotryae* on loquat leaves as predicted by Equation 5 of Table 3.1. Relative disease severity is calculated by dividing percentage of severity for each plant by the maximum severity found in the experiment35

Figure 3.8. Predicted versus observed data on relative incidence (A) and severity (B) of *Fusicladium eriobotryae* infection on loquat leaves. Data are predicted by Equation 4 and 5 of Table 3.1, respectively36

Figure 4.1. Weekly number of conidia of *Fusicladium eriobotryae* collected on horizontal slides, and scab incidence in 2011 in loquat orchard A (A) and loquat orchard B (B) relative to daily temperature and rainfall (C). In A and B, horizontal black lines (■) indicate weeks in which at least one *Fusicladium eriobotryae* conidium was detected in the rain collectors. Full triangles (▼) indicate weeks in which <100 conidia were captured on horizontal slides; empty triangles (▽) indicated weeks in which <1 mm of rain was recovered. Whiskers in A indicate standard errors for percentage of fruits with disease ..50

Figure 4.2. Weekly number of conidia of *Fusicladium eriobotryae* collected on horizontal slides, and scab incidence in 2012 in loquat orchard A (A) and loquat orchard B (B) relative to daily temperature and rainfall (C). In A and B, horizontal black lines (■) indicate weeks in which at least one *Fusicladium eriobotryae* conidium was detected in the rain collectors. Full triangles (▼) indicate weeks in which <100 conidia were captured on horizontal slides; empty triangles (▽) indicated weeks in which <1 mm of rain was recovered. Whiskers in A indicate standard errors for percentage of fruits with disease ..51

Figure 4.3. Receiver operating characteristic (ROC) curve for the weekly accumulated rainfall (mm) in relation to the probability of collecting conidia of *Fusicladium eriobotryae* (in orchard A and B during 2011 and 2012). The dotted line represents no discrimination. Also indicated are values for area under the receiver operating characteristic curve (AUROC), AUROC standard error (SE), and the probability the AUROC is different to 0.5 (P).....53

Figure 4.4. Values of the area under the disease progress curve (AUDPC) for incidence of loquat scab in orchard A in southeastern Spain in 2011 (A) and 2012 (B). Each point corresponds to the AUDPC value of one of the 46 trees in the orchard (the orchard was surveyed 14 times in 2011 and 16 times in 2012).....	54
Figure 4.5. Frequency distribution of the dispersion index (D_{tree}) of fruit with symptoms of loquat scab (caused by <i>Fusicladium eriobotryae</i>) in 46 trees of loquat in orchard A in southeastern Spain during seven sampling periods in 2011 (A: 17 January, B: 28 February, C: 14 March, D: 28 March, E: 04 April, F: 18 April and G: 02 May) and in 2012 (H: 05 January, I: 26 January, J: 16 February, K: 01 March, L: 15 March, M: 28 March and N: 12 April). The following are indicated for each sampling period: the dispersion index for the orchard ($D_{orchard}$), the probability (P) that $D_{orchard}$ is significantly >1 , and the average disease incidence (inc). Values of $D_{tree}>1$ (dotted line) indicate aggregation in the spatial pattern of disease	55
Figure 4.6. Relationship between the logarithm of the binomial variance and the logarithm of the variance of the incidence of loquat scab in orchard A in Alicante, Spain. The grey circles and black circles represent the observations from 2011 and 2012, respectively. The solid line represents the linear regression, and the dotted line represents the binomial line (i.e., when the observed variance equals the binomial variance). The regression equation between $\ln(V_{bin})$ and $\ln(V_{obs})$ and the adjusted R^2 are indicated; the probability that the intercept and slope of the regression line are > 1 is <0.001 in both cases	56
Figure 5.1. Fruit of loquat with typical symptoms of scab.....	64
Figure 5.2. The standard area diagram (SAD) set developed as an aid for assessment of scab on fruit of loquat. Each value represents the percentage of loquat scab severity on that image.....	67
Figure 5.3. Relationship between the estimates and true severity (A, B) and the absolute error (estimate minus true severity) (C, D) of assessments of a set of 50 images of scab-diseased fruit of loquat by 20 raters without (A, C) and with (B, D) the use of a standard area diagrams (SADs). Dashed line (A, B) represents the regression line	70

Figure 5.4. The relationship between gain (difference between the estimate with and without use of a standard area diagram, SAD) for measures of accuracy, precision and agreement of visual severity estimates made by 10 inexperienced (circles) and 10 experienced (triangles) raters for a set of 50 images of scab-diseased fruit of loquat (A, agreement, measured by Lin's concordance correlation coefficient; B, accuracy measured by the bias correction factor; and C, precision, measured by the correlation coefficient)..73

Figure 6.1. Disease cycle of loquat scab caused by *Fusicladium eriobotryae*82

Figure 6.2. Relational diagram showing how the model simulates infection by *Fusicladium eriobotryae*. Legend: (□) state variable), (--> flux and direction of states), (—> flux and direction of information), (—○ parameter), (○ intermediate variable), (◇ switch) (☁ outgoing variable), (⊗ valve in a flux (rate)). See Table 6.1 for acronym explanation84

Figure 6.3. Schematic representation of the infection process in terms of lesion units (LU). Each circle represents an LU that can have different states: healthy (LUH, in white), occupied by ungerminated conidia (LUUC, in green), occupied by germinated conidia (LUGC, in blue), with latent infection (LULI, in orange), or with visible scab (LUVI, in brown). Deposition, death of conidia, germination, infection, and latency progress are the phenomena that define the change of LUs from one state to another. In the example presented and in relative units, LUHC=1 at time zero and LUUC=1 at the first time step (deposition of splashing conidia). At the second time step: LUUC+LUGC+LUH=0.16+0.40+0.44=1. At the third time step: LUUC+LUGC+LULI+LUH=0.12+0.04+0.20+0.64=1. At the fourth time step: LUVI+LUH=0.20+0.80=1. Therefore, at the end of the infection process, 20% of the lesion units became infected in this example87

Figure 6.4. Dynamics of lesion units (LUs) during an infection period of *Fusicladium eriobotryae*. The graph shows the relative frequency of LUs occupied by ungerminated conidia (LUUC, in green), germinated conidia (LUGC, in red), and latent infections (LULI, in blue). Blue bars at the top indicate hours with free water on the fruit surface. An infection period starts when a rain event splashes conidia on LUs and ends when no viable conidia are present on any LUs, i.e., when LUUC≤0.0188

- Figure 6.5.** Weather data and model output in 2011. A: daily weather data; B: predicted frequency (%) of lesion units (LUs) with ungerminated conidia; C: predicted increase of LUs with latent infections (LULIs) for each infection period (arrows represent clusters of infection periods, clustering is based on an interval of at least 5 days between the beginning of two consecutive clusters); D: predicted seasonal dynamics of the cumulative values of LULI (Σ LULI).....90
- Figure 6.6.** Weather data and model output in 2012. A: daily weather data; B: predicted frequency (%) of lesion units (LUs) with ungerminated conidia; C: predicted increase of LUs with latent infections (LULIs) for each infection period (arrows represent clusters of infection periods, clustering is based on an interval of at least 5 days between the beginning of two consecutive clusters); D: predicted seasonal dynamics of the cumulative values of LULI (Σ LULI).....91
- Figure 6.7.** Comparison between model output and scab observed on loquat fruit in southeastern Spain. (A) data from 2011 and (B) data from 2012. Blue lines represent the rescaled infection predicted by the model as the seasonal summation of the lesion units with latent infections (Σ LULI). Points represent rescaled incidence of loquat fruit with scab observed in the orchards; rescaled incidence is shifted back by 21 days (red points) or 420 DD (base 0°C, green points) to account for the latency period, i.e., the time elapsed between infection and visible symptoms in the form of sporulating scab lesions..... 96
- Figure 6.8.** Comparison between model output and scab on loquat fruit in single-exposure experiments. Experiments were carried out in a loquat orchard in southeastern Spain in 2013. Observed data (X axis) are expressed as the rescaled disease severity in 11 groups of fruits that were exposed (for 7-day-long moving periods) to splashing rain in a severely affected orchard; model output (Y axis) is expressed as the summation of the lesion units with latent infections (Σ LULI) in the exposure period 97
- Figure 6.9.** Comparison between model output and expert assessment in southeastern Spain from 2006 to 2013. Loquat severity was estimated as low, medium, or high by an expert advisor; bars show the average number (+ SE) of scab outbreaks predicted by the model in each severity category. A disease outbreak was defined as Σ LULI>0.1 in 1 day, when no outbreaks were predicted on the previous 5 days 98

Figure 8.1. Relative severity on loquat plants inoculated with *Fusicladium eriobotryae* and treated with five different fungicides at different times of application. Relative disease severity was calculated as the percentage of severity relative to the median value of severity on control plants. For each combination of fungicide and time of application eight plants were inoculated. Bars represent the standard error..... 121

Figure 9.1. Schematic representation of the β -tubulin gene showing the binding sites of the primers used in this study and the point mutations associated to thiophanate-methyl resistance. Black boxes denote protein-coding sequences (exons), and white boxes denote introns..... 128

Figure 9.2. Distributions of relative growth (RG) values of *Fusicladium eriobotryae* isolates (n=249) on A, difenoconazole and B, thiophanate-methyl. Bars represent number of isolates in each RG category and dotted vertical lines indicate the average RG value for each fungicide. 130

Figure 9.3. Map of Spanish locations from which isolates of *Fusicladium eriobotryae* resistant to difenoconazole (black circle), thiophanate-methyl (black diamond) or both (black triangle) were found. White circles indicate locations at which no resistant isolates were found. Provinces: ALM, Almería; ALC, Alicante; CA, Castellón; GR, Granada; and VA, Valencia. 131

Chapter 1

GENERAL INTRODUCTION

Loquat cultivation

Botany, history and ecophysiology

Loquat (*Eriobotrya japonica* (Thunb) Lindl.) is a fruit tree belonging to the family Rosaceae, subfamily Maloideae (Soriano *et al.*, 2005). *E. japonica*, which is the only edible species of the genus *Eriobotrya*, is native from China and records on loquat in this country span more than 2000 years ago (Zhan *et al.*, 1990; Zhao *et al.*, 2011). Loquat was introduced to Japan from China and from there, was spread to Mediterranean countries, including Italy and Spain; now it is grown between latitudes 20° and 35° North or South (Rodríguez, 1983; Gisbert *et al.*, 2006; Lin *et al.*, 1999).

Loquat is a subtropical evergreen species which, in the north hemisphere, blooms in autumn, develops the fruit in winter, and ripens in early spring (Janick, 2011). The tree has three flushes of growth per year: in spring (the main one), summer and autumn (Martínez-Calvo *et al.*, 1999). Frost sensitivity restricts its production to temperate climate (Kottek *et al.*, 2006), as temperatures below -2°C damage open flowers and fruit (Caballero and Fernández, 2002).

Distribution and production

In general, loquat is considered a minor fruit crop, i.e. a crop that is high in value but not widely grown (Womach, 2005). The main areas for commercial cultivation of loquat are eastern Asia (China and Japan), and the Mediterranean basin (being Spain, Israel, Italy and Turkey the main producing countries in this area) (Lin *et al.*, 1999; Gisbert *et al.*, 2006; Janick, 2011). According to the literature, Brazil and Chile are the most important producers in America, although the commercial cultivation of loquat in these countries started in the last decade (Caballero and Fernández, 2002; Fichet and Razeto, 2002). California and Florida had commercial loquat orchards in the past (Condit, 1915; Lin *et al.*, 1999), although currently cultivation is restricted only to private grounds and as an ornamental plant (Crane and Caldeira, 2013).

China is the main producer of loquat fruit worldwide, being Spain the second one and the main producer country in the Mediterranean basin, exporting almost 50% of its total production (Soler *et al.*, 2007) (Table 1.1). In Spain, loquat production is mainly located in three provinces from the eastern coast: Alicante

(16,000 t), Granada (9,717 t) and Málaga (1,950 t) (Caballero and Fernández, 2002; MAGRAMA, 2013).

Table 1.1. Loquat world production.

Country	Area (ha)	Production (t)	Reference
China	118,270	453,600	Lin, 2007
Spain	2,914	41,487	Magrama, 2013
Turkey	-	12,600	Celikyurt <i>et al.</i> , 2011
Pakistan	1,501	10,479	Abbasi, 2011
Japan	2,420	10,245	Caballero and Fernandez, 2002
Italy	199	6,457	Istat, 2014
Morocco	385	6,400	Caballero and Fernandez, 2002
Israel	330	3,000	Caballero and Fernandez, 2002
Greece	300	2,750	Caballero and Fernandez, 2002
Brazil	300	2,400	Caballero and Fernandez, 2002
Egypt	122	1,273	Elsabagh, 2011
Portugal	243	950	Caballero and Fernandez, 2002
Taiwan	1,000	-	Shih, 2007
Chile	120	-	ODEPA, 2014

Loquat commercial production is mainly based on family farms, with small high-density plots (Caballero and Fernández, 2002; Fichet and Razeto, 2002; Lin, 2007; Abbasi *et al.*, 2011; Celikyurt *et al.*, 2011; Elsabagh, 2011). In Spain, farmers are organized in cooperatives, and production of high commercial quality fruits requires an intensive calendar of cultural practices (Soler *et al.*, 2007).

Cultivars and rootstocks

Three cultivars have been mostly used worldwide in commercial fields: Tanaka, Algerie and Golden Nugget (Caballero and Fernández, 2002). Thus, lack of cultivar diversity in commercial production is considered one of the main problems of loquat cultivation (Lin *et al.*, 1999; Gisbert *et al.*, 2007). Currently, Spain, Japan and China are developing cultivar breeding programs and managing germplasm collections (Lin, 2007; Martínez-Calvo *et al.*, 2007). Loquat is propagated mainly by budding or grafting and seedlings of *Cydonia oblonga*

Mill., *E. japonica*, *E. deflexa* Nakai or *Photinia serrulata* Lindl. are commonly used as rootstocks (Lin *et al.*, 1999; Lin, 2007; Soler *et al.*, 2007).

Physiological disorders, pests and diseases

Purple spot and russetting are important physiological disorders associated to loquat crop, which decrease the market value of fruit because they severely affect visual quality (Wang *et al.*, 2007). Purple spot occurs worldwide and reductions in commercial value by 40-50% have been reported in Spain and Israel (Gariglio *et al.*, 2003; Avidan and Klein, 2003).

In the Mediterranean basin, no important damages caused by pests have been reported associated to loquat production (Caballero and Fernández, 2002). Lin *et al.* (1999) indicated that in Japan, insect pests affecting loquat require, in some cases, management practices. The fruit fly *Anastrepha suspensa* (Loew) has been identified as one of the reasons why loquat is no longer grown commercially in Florida (Lin *et al.*, 1999).

In the last decades, different pathogens have been reported causing diseases in loquat trees (Table 1.2). Several fungal species, such as *Armillaria mellea* (Vahl) P. Kumm, *Rosellinia necatrix* Berl. Ex Prill. and *Phytophthora nicotianae* Breda de Hann, *P. citrophthora* (R.E. Sm. & E.H. Sm.) Leonian, *P. cambivora* (Petri) Buisman, *P. cactorum* (Lebert & Cohn) J. Schröt and *P. cryptogea* Pethybr. & Laff. have been identified associated with root rot symptoms in Spain (González-Domínguez *et al.*, 2009). Specially for *Phytophthora* spp., severe attacks have been reported in different countries and, in most cases, the plants eventually die (Miller, 1942; Frisullo *et al.*, 1997; Chern *et al.*, 1998; González-Domínguez *et al.*, 2009).

Regarding diseases affecting the canopy of the tree, several fungal species belonging to the family Botryosphaeriaceae have been reported causing branch dieback in Spain (González-Domínguez *et al.*, 2012) and Chile (Besoain and Fuentes, 1988; Palma *et al.*, 2006). Spots on leaves and fruits due to *Pestalotiopsis* spp. and *Entomosporium mespili* (DC.) Sacc. have been reported worldwide (Ogawa and English, 1991; Crane and Caldeira, 2013). In addition, in the Mediterranean basin, Chile and USA, spots on leaves and fruits are mainly associated to the fungus *Fusicladium eriobotryae* (Cavara) Sacc., the causal agent of loquat scab (Saad, 1959; Salerno *et al.*, 1971a; Raabe and Gardner, 1972; Andrade *et al.*, 1984; Sánchez-Torres *et al.*, 2009; Celikyurt *et al.*, 2011). This disease will be described separately because its study is the objective of this thesis.

In Japan, canker formation by the bacterial pathogen *Pseudomonas syringae* pv. *eriobotryae* Young, Dye & Wilkie is considered an important disease of loquat (Morita, 2001), while in other countries like Argentina, New Zealand and USA, other species of *Pseudomonas* have been described associated to canker formation (Table 1.2). In Israel, an outbreak of fire blight caused by *Erwinia amylovora* (Burill) Winslow *et al.* devastated the loquat industry in the 90s (Zilberstaine *et al.*, 1996; Manulis *et al.*, 1998); in USA, the death of loquat plants due to fire blight infections have also been reported (Ogawa and English, 1991; Crane and Caldeira, 2013).

Regarding postharvest conditions, *Colletotrichum acutatum* J.H. Simmonds and *Alternaria tenuis* Nees are considered the most important pathogens in China associated to fruit rot (Gu *et al.*, 2007; Liu *et al.*, 2007). In Spain, very recently, fruit rot due to *Diplodia seriata* De Not. (Palou *et al.*, 2013b) and *Pestalotiopsis clavispora* (G.F. Atk.) Steyaert (Palou *et al.*, 2013a) have been described.

Loquat scab caused by *Fusicladium eriobotryae*

Loquat scab caused by *Fusicladium eriobotryae* (Cavara) Sacc. is the main disease affecting this crop in the Mediterranean basin (Sánchez-Torres *et al.*, 2009; Gladieux *et al.*, 2010). The fungus was first described in Italy in 1892 (Briosi and Cavara, 1892) and subsequent references indicate that it is an important problem in Italy (Salerno *et al.*, 1971a), Lebanon (Saad, 1959), Spain (Sánchez-Torres *et al.*, 2009), and Turkey (Celikyurt *et al.*, 2011).

Symptomatology

F. eriobotryae can infect leaves and fruits, and, under severe attacks, symptoms can be observed in young twigs (Fig. 1.1 A). Despite Rodriguez (1983) and Gisbert *et al.* (2006) state that flowers are susceptible to *F. eriobotryae*, these symptoms have not been properly described and the pathogen has never been isolated from them. In leaves and fruits, first symptoms appear in the form of few circular chlorotic spots, which progressively increase in number (Fig. 1.1 B) (Sánchez-Torres *et al.*, 2009). The fungus grows first subcuticularly, forming a stroma and, with the initiation of the conidiogenesis, forcing the cuticle until its rupture (Fig. 1.1 C). Visible lesions become olive colored and velvety due to the production of conidia (Fig 1.1 D; 1.1 E) (Sánchez-Torres *et al.*, 2009). As the lesions increase in size, spots can coalesce, covering most of fruits and leaves surfaces (Fig 1.1 F; 1.1 G) (Prota, 1960; Gisbert *et al.*, 2006).

Table 1.2. Diseases affecting loquat

Disease	Pathogen	Countries	Reference
Root diseases			
Root rot	<i>Armillaria mellea</i>	Spain	González-Domínguez <i>et al.</i> , 2009
Root rot	<i>Phytophthora</i> spp.	Italy, Peru, Spain, China, USA	Miller, 1942; Frisullo <i>et al.</i> , 1997; Chern <i>et al.</i> , 1998; González-Domínguez <i>et al.</i> , 2009; Hurtado-Gonzales <i>et al.</i> , 2009; Crane and Caldeira, 2013
Root rot	<i>Rosellinia necatrix</i>	China, Spain, USA	Duan <i>et al.</i> , 1990; Ogawa and English, 1991; Lin <i>et al.</i> , 1999; González-Domínguez <i>et al.</i> , 2009
Aerial diseases			
Branch dieback	<i>Botryosphaeriaceae</i>	Chile, USA, Spain	Besoain and Fuentes, 1988; Palma <i>et al.</i> , 2006; González-Domínguez <i>et al.</i> , 2012; Crane and Caldeira, 2013
Leaf spot	<i>Entomosporium mespili</i>	Chile, Korea, USA	Gómez, 1988; Ogawa and English, 1991; Seo <i>et al.</i> , 2011
Fire Blight	<i>Erwinia amylovora</i>	Israel, USA,	Ogawa and English, 1991; Zilberstaine <i>et al.</i> , 1996; Manulis <i>et al.</i> , 1998; Crane and Caldeira, 2013
Leaf and fruit scab	<i>Fusicladium eriobotryae</i>	Chile, Italy, Lebanon, Spain, Turkey, USA	Saad, 1959; Salerno <i>et al.</i> , 1971a; Raabe and Gardner, 1972; Andrade <i>et al.</i> , 1984; Sánchez-Torres <i>et al.</i> , 2009; Celikyurt <i>et al.</i> , 2011
Leave and branch spots	<i>Pestalotiopsis</i> spp.	Argentina, China	Perelló and Larrán, 1999; Gu <i>et al.</i> , 2007; Fang and Wang, 2013
Stem canker	<i>Pseudomonas</i> spp.	Argentina; Japan, New Zealand; USA	Lai <i>et al.</i> , 1971; McRae and Hale, 1986; Alippi, 1990; Morita, 2001
Postharvest diseases			
Anthraxnose	<i>Alternaria tenuis</i>	China	Gu <i>et al.</i> , 2007
Anthraxnose	<i>Colletotrichum acutatum</i>	China, USA	Gu <i>et al.</i> , 2007; Liu <i>et al.</i> , 2007; Crane and Caldeira, 2013
Fruit rot	<i>Diplodia seriata</i>	Spain	Palou <i>et al.</i> , 2013b
Fruit rot	<i>Pestalotiopsis clavispora</i>	Spain	Palou <i>et al.</i> , 2013a

Old lesions become brown and corky in the center as the fungus dies (Fig 1.1 H), reducing the sporulated area to the edge of the lesion (Prota, 1960). Although no specific studies have been done regarding changes in the susceptibility of loquat leaves, fruits and twigs along its growth stages, Rodríguez (1983) affirmed that fruit are susceptible during all their development; however, regarding leaves, Prota (1960) suggested that mature, glabrous loquat leaves were not susceptible to new *F. eriobotryae* infections.

Severe attacks of *F. eriobotryae* on young fruits and leaves could deform the organs; severe attacks on twigs result in branch cankers and dieback (Saad, 1959; Rodríguez, 1983). In years with favorable environmental conditions for the pathogen, more than 50% of fruits can be damaged, making them unsuitable for the market (Fig 1.1 I) (Salerno *et al.*, 1971b; Rodríguez, 1983).

Taxonomy

Fusicladium Bonord. species are the anamorphs of genus *Venturia* Sacc. (Schubert *et al.*, 2003). *Venturia* spp. belongs to the phylum Ascomycota, class Dothideomycetes (Schoch *et al.*, 2009). This genus had been included in the order Pleosporales (Sivanesan, 1977), but recent phylogenetic analyses have reordered it into Venturiales ord. nov. (Zhang *et al.*, 2011)

Traditionally the anamorphs of *Venturia* spp. had been classified in three different genera, *Fusicladium*, *Pollaccia* Baldacci & Cif. and *Spilocaea* Fr., depending on morphological differences in the conidiogenous cells, which were sympodial in *Fusicladium* and percurrent in *Pollaccia* and *Spilocaea* (Schubert *et al.*, 2003). However, a recent morphological and molecular re-examination concluded that anamorphic species of *Venturia* should not be separated in these three groups because: (i) both sympodial and percurrent conidiogenous cells are present in most of the species, and (ii) molecular examinations clearly show that *Venturia* is a monophyletic unit (Schubert *et al.*, 2003). As the anamorphs of *Venturia* had been classified mainly as *Fusicladium*, this name has been proposed to designate the asexual stage of *Venturia* spp. (Braun *et al.*, 2002).

Hosts of *Venturia* spp. with conidial stages are confined to six families: Aceraceae, Betulaceae, Cornaceae, Oleaceae, Rosaceae and Salicaceae (Sivanesan, 1977). Many species of *Venturia* are notable pathogens of fruit trees, causing scab diseases in apple (*Venturia inaequalis* (Cooke) G. Winter), pear (*V. pyrina* Aderh. and *V. nashicola* S. Tanaka & S. Yamam.), peach (*Fusicladium carpophilum* (Thüm.) Oudem.), pecan (*F. effusum* G. Winter), olive (*F. oleagineum* (Castagne) Ritschel & U. Braun), pyracantha (*F. pyracanthae* (Thüm.) O. Rostr.) and loquat (*F. eriobotryae*) (Sivanesan, 1977; Schubert *et al.*, 2003; Zhang *et al.*, 2011).



Figure 1.1. **A**, young loquat twig affected by scab; **B**, first symptoms of scab (circular chlorotic spots) in a loquat leaf; **C**, conidia of *Fusicladium eriobotryae* arising from the cracked cuticle of a loquat leaf; **D**, loquat fruit showing initial scab lesions (olive colored and velvety); **E**, stroma producing conidia in a loquat leaf; **F**, fruit showing several lesions that coalesce; **G**, loquat leaf severely affected by scab; **H**, fruit severely affected by scab with old (brown, corky) and young (olivaceous) lesions; **I**, loquat tree severely affected by scab.

Molecular characterization of *F. eriobotryae* revealed a high grade of similarity with other Venturiaceae species, mainly with *V. inaequalis* and *F. pyracanthae* (Le Cam *et al.*, 2002; Sánchez-Torres *et al.*, 2009; Gladieux *et al.*, 2010). In fact, no differences were found when these three pathogens were compared in the internal transcribed spacer regions (ITS) of the ribosomal DNA (Le Cam *et al.*, 2002; Sánchez-Torres *et al.*, 2009). Furthermore, a high sequence similarity was observed among them in other DNA regions, such as the genes actin, translation elongation factor 1- α or glyceraldehyde 3-phosphate dehydrogenase (Sánchez-Torres *et al.*, 2009; Gladieux *et al.*, 2010). Consequently, based on the criterion of concordance between multiple gene genealogies (Taylor *et al.*, 2000), Gladieux *et al.* (2010), determined that *V. inaequalis*, *F. eriobotryae* and *F. pyracanthae* should be dealt as a unique species. The same authors, considering previous host specificity experiments (Raabe and Gardner, 1972; Le Cam *et al.*, 2002), renamed them as: *V. inaequalis* f.sp. *pomi* for the causal agent of scab in apple, and *V. inaequalis* f.sp. *pyracanthae* for the causal agent of scab in pyracantha and loquat. To support this hypothesis, Gladieux *et al.* (2010) assumed that a certain grade of sexual recombination should occur in isolates from pyracantha and loquat; however, to our knowledge, no sexual structures have been found in the pathogen infecting loquat or pyracantha. D'Oliveira and D'Oliveira (1946) performed a detailed observation of loquat leaf litter in a period comprised from 1928 to 1936 and they were unable to find sexual structures.

There are several criteria that can be used for species delimitation that not always concur. The availability of molecular techniques has made the criteria based on phylogenetic species very popular, but more conservative approaches should also be considered (Hibbett and Taylor, 2013). For asexual fungi, Giraud *et al.* (2008) considered that host-specificity could be a criterion for species delimitation. This criterion is based on the hypothesis that the acquisition of abilities to infect new hosts can form new species, because recombination will not prevent the differentiation from the ancestral populations. It is known that the criterion of concordance between multiple gene genealogies (Taylor *et al.*, 2000) followed by Gladieux *et al.* (2010) benefits the most parsimonious hypothesis. However, for loquat scab, the traditional denomination of the causal agent (Menon, 1956; Saad, 1959; Prota, 1960; Rodríguez, 1983) as *F. eriobotryae* makes it recognizable (Sánchez-Torres *et al.*, 2009). Moreover, substantial differences exist among the ecophysiology of the hosts (apple, loquat and pyracantha) and life cycle of the pathogens. For these reasons from now on, in this thesis the causal agent of loquat scab will be named as *Fusicladium eriobotryae*.

Biology and epidemiology

Little is known about the biology and epidemiology of *F. eriobotryae*. Sánchez-Torres *et al.* (2009) studied *in vitro* the mycelial growth of different isolates of *F. eriobotryae* at 21°C. Results showed that this fungus has a slow growth rate (0.7-0.9 mm day⁻¹) at this temperature on culture media. Moreover, these authors inoculated loquat plants with *F. eriobotryae*, keeping them for 1 week in 100% humidity, and then transferring the plants to ambient relative humidity in greenhouses. Infected plants exhibited first symptoms 21 days postinoculation which progressively increased in severity until 34 to 38 days. Substantial differences were observed in final disease severity among the *F. eriobotryae* strains evaluated, with percentages of leaf necrotic area ranging between 20 and 80% (Sánchez-Torres *et al.*, 2009).

In Sardegna, Prota (1960) conducted a one year field study, making periodical observations on epidemiological aspects of the disease on loquat leaves. In this study, increases in scab severity were higher from February-March to June-July, affecting spring leaf flush. Infections occurred in subsequent flushes, during summer and autumn, but disease symptoms were less severe (Prota, 1960). Spring lesions sporulated profusely during one month, until the beginning of the summer, whereas autumn lesions produced conidia for 5 or 6 months, until the summer. All year long, *F. eriobotryae* conidia had a high percentage of germination, usually between 70 and 90% (Prota, 1960).

Salerno *et al.* (1971a) assessed weekly the incidence of loquat scab in leaves and fruits in two orchards located in Palermo (Sicily) during two consecutive growing seasons. In addition, in order to evaluate the disease incubation period, trap loquat plants were exposed during three days within affected trees in the orchards and incubated afterwards until symptoms appearance. In both years, leaf symptoms appeared in November-December, whereas fruit symptoms were found from January to April. These authors concluded that infection development was strongly associated to temperature; infections stopped when the daily average temperature was below 10°C, or up to 20°C. Moreover, the incubation period ranged between 11-13 and 24-26 days with daily average temperature of 16°C and 11°C, respectively (Salerno *et al.*, 1971a). This period rose up to more than 200 days with trap plants exposed in April, when temperature was up to 20°C. In this case, the last spring infection seemed to be the main inoculum source for the next season (Salerno *et al.*, 1971a).

Disease management

In the absence of specific research, management of loquat scab in Spain and Italy is based on studies developed for apple scab (*V. inaequalis*), including both, chemical and cultural management measures (GVA, 2013; DRA, 2014).

In Alicante province, the plant health service uses the Mills-Laplante tables to schedule the application of fungicides (Mills and Laplante, 1954; GVA, 2013). These curves mark out three levels of apple scab infection risk as a function of daily mean temperature and hours of leaf wetness.

Regarding the fungicides currently used to control *F. eriobotryae* in Spain, a copper-based fungicide treatment in October is recommended during flowering (Table 1.3). From November to March, it is recommended to combine a systemic fungicide with a protective one, in order to avoid resistance appearance (Brent and Hollomon, 2007a). In Italy, integrated pest management (IPM) guide for *F. eriobotryae* recommend the use of copper-based fungicides or dodine; for this latter, no more than two applications per season (DRA, 2014). In both countries, removing mummified fruits and twigs with canker lesions is recommended by the plant health services in order to reduce the inoculum level in the orchards (GVA, 2013; DRA, 2014).

Table 1.3. Fungicide schedule recommended for the management of loquat scab in Alicante province (Spain) (GVA, 2013).

October	November	December	January	February	March
Blossom			Fruit thinning		
Copper	Difenoconazole Ciproconazole Myclobutanil	+ Mancozeb Maneb Metiram		Difenoconazole Myclobutanil	+ Captan

Little is known about the efficacy of different active ingredients against *F. eriobotryae*. Regarding this subject, two field experiments were carried out in Lebanon (Saad, 1959), and Sicily (Salerno *et al.*, 1971b), but most of the fungicides evaluated are not currently allowed in the EU. In Lebanon, captan gave excellent control of loquat scab, whereas in Sicily, dodine and ziram showed the best results (Saad, 1959; Salerno *et al.*, 1971b).

Chapter 2

OBJECTIVES

Scab, caused by *Fusicladium eriobotryae*, is the main disease affecting loquat in Spain and other countries in the Mediterranean basin. However, *F. eriobotryae* has received little attention by plant pathologists.

Spanish farmers have been aimed to manage loquat scab according to the information available for apple scab. Currently, in Alicante province, the apple scab infection model developed by Mills and Laplante (1954) is used to guide fungicide application for the control of loquat scab. It has been previously reported that Mills-Laplante table over-predicts the number of infections for apple scab (MacHardy *et al.*, 1989). This could also happen for loquat scab, because in the last eight years, in average, 10 warnings of high risk infections per year have been marked and, occasionally, more than 15.

Loquat crop is an important source of income in some towns in Alicante province such as Callosa d'En Sarrià, Altea and Polop, in which years with a high disease incidence result in severe economic losses. Consequently, field technicians and farmers involved in loquat cultivation demand specific tools for the management of loquat scab.

This thesis has been funded by the Cooperativa Agrícola de Callosa d'En Sarrià, with the overall objective to improve the knowledge of loquat scab for a better management of the disease. For this purpose, specific research about the biology and epidemiology of *F. eriobotryae* must be conducted. The results will be used to design an epidemiological model for disease prediction in field. Furthermore, specific tools for the assessment of loquat scab and for the detection of *F. eriobotryae* are needed. Finally, regarding disease control based on fungicide applications, two main aspects must be evaluated: (i) the efficacy of the main fungicide classes against *F. eriobotryae* and (ii) the appearance of resistance to the site-specific fungicides commonly used in Spain.

Following these aims, the research developed in this thesis is organized in the following chapters:

Chapter 3 determines the influence of environmental factors on mycelial growth and conidial germination of *F. eriobotryae*, and the influence of temperature and wetness duration into the infection of loquat leaves.

Chapter 4 describes the dispersal of *F. eriobotryae* conidia in relation to weather conditions and evaluates the spatial pattern of scab in loquat orchards.

Chapter 5 develops and evaluates a standard area diagram for estimating loquat severity on fruits.

Chapter 6 develops a weather-based model for predicting loquat fruit infection by *F. eriobotryae* and evaluates its accuracy versus different data sets.

Chapter 7 develops a PCR-based protocol for *in planta* detection of *F. eriobotryae*.

Chapter 8 evaluates the *in vitro* efficacy of different fungicides against *F. eriobotryae*, and determines its pre- and post-infection activity.

Chapter 9 studies the appearance in Spain of *F. eriobotryae* resistance to the site-specific fungicides difenoconazole and thiophanate-methyl.

Chapter 3

Effect of environmental factors on mycelial growth and conidial germination of *Fusicladium eriobotryae*, and the infection of loquat leaves

E. González-Domínguez¹, V. Rossi², J. Armengol¹, and J. García-Jiménez¹ (2013). *Plant Disease* 97:1331-1338.

¹Instituto Agroforestal Mediterráneo, Universidad Politécnica de Valencia, Camino de Vera s/n, 46022-Valencia, Spain.

²Istituto di Entomologia e Patologia vegetale, Università Cattolica del Sacro Cuore, 29122 Piacenza, Italy.

Abstract

In Spain, loquat scab caused by *Fusicladium eriobotryae* is usually controlled by fungicides when there are favorable conditions for infection. Lacking specific data on the effect of weather conditions on infection by *F. eriobotryae*, infection periods are predicted based on the Mills table for apple scab. Experiments were conducted to determine the influence of temperature, wetness duration, relative humidity (RH) and dry periods on mycelial growth, conidial germination and infection of loquat leaves by *F. eriobotryae*. *F. eriobotryae* was able to grow and the conidia to germinate in a wide range of temperatures, whereas no germination occurred at RH<100%. Maximum conidial germination occurred with 24 h of wetness and germination was strongly reduced by >10 h dryness interrupting the wetness period. Loquat infection occurred between 10 and 20°C, and disease incidence and severity increased as the duration of wetness period increased. The combined effect of temperature and wetness duration on conidial germination of *F. eriobotryae* and leaves infection was described by combining beta and Gompertz equations, while the effect of dry periods on reducing the conidial germination was described by a logarithmic equation. The equations developed in this work provided a reasonable fit of the biological processes investigated and could be used for better disease control; they could be further integrated in a disease prediction system for scheduling fungicide sprays against loquat scab.

Introduction

Loquat (*Eriobotrya japonica* (Thunb) Lindl.) is a fruit tree native of China, which is mainly cultivated in Asia, Australia, South America, the United States and the Mediterranean basin (Caballero *et al.*, 2002; Calabrese, 2006; Reig *et al.*, 2012). In temperate zones of the Northern hemisphere, loquat trees bloom in

autumn, and develop fruits in winter, which are mature for harvest in spring (Reig *et al.*, 2012).

In the Mediterranean basin, loquat scab caused by *Fusicladium eriobotryae* (Cavara) Sacc. is the main disease affecting this crop (Soler *et al.*, 2007; Sánchez-Torres *et al.*, 2009; Gladieux *et al.*, 2010). *F. eriobotryae* can infect leaves, shoots and fruits, mostly in early stages of their development. The symptoms of loquat scab, which are quite similar to those described for apple scab (Sánchez-Torres *et al.*, 2009), are generally noticeable and serious on both sides of leaves and on fruits as green to olive-brown spots, which increase in size and can cover almost all their surfaces (Sánchez-Torres *et al.*, 2007a; Sánchez-Torres *et al.*, 2007b). Scabby fruits are unsuitable for the market, resulting in significant economic losses (Sánchez-Torres *et al.*, 2009).

Fusicladium species are the anamorphic stages of the ascomycete genus *Venturia*, but the sexual stage of *F. eriobotryae* has never been found in nature (Gladieux *et al.*, 2010). The epidemiology of other diseases caused by these pathogens, such as *Venturia inaequalis* (James and Sutton, 1982; Boric, 1985; Becker *et al.*, 1994; MacHardy, 1996; Hartman *et al.*, 1999), *V. nashicola* (Li *et al.*, 2003; 2005), *V. pyrina* (Spotts and Cervantes, 1991; Villalta *et al.*, 2000a; Villalta *et al.*, 2000b), *F. carpophilum* (Lawrence and Zehr, 1982), *F. effusum* (Gottwald, 1985) or *F. oleagineum* (Obanor *et al.*, 2008b; Obanor *et al.*, 2010; Viruega *et al.*, 2011) is well understood. Results of some of these studies have been used to elaborate epidemiological models (Rossi *et al.*, 2007; 2009; Eikemo *et al.*, 2011; Roubal *et al.*, 2013) that allow growers to predict the development of the disease, helping them in responding timely and efficiently (De Wolf and Isard, 2007).

Understanding the key factors that affect the development of plant disease epidemics is essential to design and implement effective strategies for disease management (De Wolf and Isard, 2007). Although loquat scab is a well-recognized problem and an important limiting factor for loquat production in the main growing areas of the Mediterranean basin, little is known about the biology of the pathogen, and no specific research has been conducted to understand its epidemiology or to develop disease models (Sánchez-Torres *et al.*, 2009). In Spain, the regional plant health services use the Mills-Laplante tables (Mills and Laplante, 1954) to monitor the risk of infection by *F. eriobotryae* (GVA, 2013). These tables have been elaborated for *V. inaequalis* and disagreement between the risks indicated by the tables and the real infection has been repeatedly found since they were developed (MacHardy, 1996).

Laboratory and controlled-environment experiments provide information on epidemic components that is crucial to the understanding of epidemics

(Campbell and Madden, 1990). Moreover, the knowledge of these epidemic components is the first step for the development of a disease risk model. Thus, the objectives of this study were to: i) determine the influence of temperature, wetness duration, relative humidity, and dry periods on mycelial growth and conidial germination of *F. eriobotryae*; and ii) evaluate the infection of loquat leaves by *F. eriobotryae* under different regimes of temperature and wetness duration.

Materials and methods

Fungal isolates. Six isolates of *F. eriobotryae* (FE-3, FE-6, FE-17, FE-31, FE-36 and FE-40) were obtained in 2008 from diseased loquat fruits collected in several locations of the Comunidad Valenciana region (eastern Spain) and used in this study. These isolates were single spored by means of the serial dilution method (Dhingra and Sinclair, 1985), stored in 15% glycerol solution at -80°C in 1.5 mL cryovials, and maintained in the fungal culture collection of the Instituto Agroforestal Mediterráneo (Universidad Politécnica de Valencia). Prior to use, a small plug of the colonized agar from each cryovial was transferred to potato dextrose agar (PDA) (Biokar-Diagnostics, Zac de Ther, France) and incubated at 20°C in darkness for two months. In all experiments, except for the evaluation of mycelial growth, conidial suspensions of 5×10^5 conidia ml^{-1} were used. Suspensions were obtained by flooding two-month old cultures of each isolate with 10 ml of sterile distilled water and scrapping the cultures with a sterile spatula. The resulting conidial suspension was filtered through two layers of cheese cloth and the filtrate was adjusted to 5×10^5 conidia ml^{-1} with a hemacytometer.

Effect of temperature on mycelial growth. To determine the effect of temperature on mycelial growth, plugs of agar, 5 mm in diameter, were cut from the margins of two-month old cultures of *F. eriobotryae* and placed in the centre of PDA plates that were incubated in the dark at 5, 10, 15, 20, 25, 30 and 35°C . The six isolates were used in this experiment, with five replicate plates per isolate and temperature combination. After one month of incubation, colony diameter was measured along two perpendicular axes, and data were converted to daily radial growth (mm day^{-1}). Each of the culture plates incubated at temperatures in which there was no growth were placed at 20°C to determine if these temperatures were fungistatic or fungicidal. The experiment was repeated once.

Effect of temperature and wetness duration on conidial germination. The effect of temperature and wetness duration on conidial germination of *F. eriobotryae* was evaluated under six different temperature regimes (5, 10, 15, 20, 25 and 30°C) and six wettings periods (6, 12, 18, 24, 36 and 48 h). Isolates FE-6, FE-31, FE-36 and FE-40 were used in this experiment. For each combination of isolate, temperature and wetness duration, three 10- μ l drops of the conidial suspensions were placed on a microscope slide and incubated in a moist chamber at 100% relative humidity (RH) in darkness. The moist chamber was prepared filling a hermetic plastic clear box with 80 ml of sterile distilled water, with the slide placed over a plastic grid. One moist chamber was used for each combination of temperature and wetness duration. At the end of each wetness period, the percentage of germinated conidia was determined by examining 200 conidia on each drop by using a microscope (x40 magnification). A conidium was considered germinated if its germ tube was at least one-half the length of the conidium. The experiment was repeated once.

Effect of relative humidity on conidial germination. In this experiment, the germination of conidia of *F. eriobotryae* was evaluated at five different levels of RH: 100, 98, 95, 90 and 80.5%. To obtain the different RH regimes, the moist chambers described above were filled with 80 ml of different saturated salts solutions (Dhingra and Sinclair, 1985): $K_2Cr_2O_7$ for 98% RH, Na_2SO_3 for 95% RH, $MgSO_4 \cdot 7H_2O$ for 90% RH and $(NH_4)_2 \cdot SO_4$ for 80.5% RH. Prior to use, the chambers were equilibrated at the respective temperatures for at least 12 h. The germination of conidia at each RH was evaluated under three temperature regimes (15, 20 and 25°C) and seven incubation periods (6, 12, 18, 24, 36, 48 and 60 hours). Two isolates, FE-6 and FE-40, were used in this experiment. For each combination of isolate, temperature, incubation time and RH regime, three drops of 10- μ l of conidial suspensions were placed on one microscope slide. Prior to introduce the slide in the moist chamber, the drops with the conidial suspensions were dried in a laminar flow sterile cabinet for 20 minutes. One slide with three drops of 10- μ l of conidial suspension, which was not dried, was incubated in a saturated atmosphere as a control for each combination of isolate, temperature and incubation period. One moist chamber was used for each isolate, temperature and RH regime. The evaluation of conidial germination was performed as described before. The dried drops were rewetted with sterile distilled water to facilitate the microscope observations. The experiment was repeated once.

Effect of dry periods on conidial germination. In this experiment, the effect of five dry periods (6, 12, 24, 48 and 72 h) interrupting two wetness periods on conidial germination of *F. eriobotryae* was evaluated. Two initial wetness periods of 6 and 12 h and two levels of RH for the dry period (20 and 60%) were tested. In all combinations of initial wetness and RH, once the dry period had finished, the conidia were incubated in a moist chamber with saturated atmosphere for a final wetness period of 12 h. The moist chamber for the initial and final wetness period was prepared as described for the experiment of the effect of temperature and wetness duration on conidial germination. Isolates FE-6 and FE-40 were used in this experiment. For each combination of isolate, initial wetness period, dry period and RH regime during the dry period, three drops of 10- μ l of conidial suspensions were placed on a microscope slide. For the initial and final wetness periods, one moist chamber was prepared for each isolate and RH regime. For the dry period, two different moist chambers were used; with no water, corresponding to 20% RH (measured by a small data logger [Watchdog® 450, Spectrum Technologies, Inc., Plainfield, IL, USA]), or with 80 ml of a saturated solution of NH_4NO_3 , corresponding to 60% RH (Dhingra and Sinclair, 1985). Once the initial wetness period of 6 or 12 h had finished, the drops were dried in a laminar flow sterile cabinet for 20 minutes. After the drops were evaporated, the slides were placed in the chambers at either 20% or 60% RH for the different periods. Following each dry period, conidia on the slides were rewetted with sterile water and incubated in moist chambers at 100% RH for 12 h. Conidia maintained for 18 h under continuous wetting were used as control. All the experiment was conducted at 20°C in darkness. Percentage of conidial germination was evaluated as described before. The experiment was repeated once.

Effect of temperature and wetness duration on leaves infection. Infection on loquat leaves was evaluated under seven wetness periods (6, 12, 18, 24, 36, 48 and 60 h) and four temperature regimes (10, 15, 20 and 25°C). Six month-old loquat leaves of the susceptible cv. Algeria were used. Plants were grown in a growth chamber (20°C; 60% RH; 12h light/12h darkness) and were inoculated when they had four fully expanded leaves. For inoculation, the isolate FE-40 was used. A uniform layer of fine droplets of a conidial suspension was gently sprayed on leaves using a hand sprayer (W560, Wagner Spraytech Iberica S.A., Spain). Following inoculation, plants were covered with plastic bags to ensure leaf wetness and placed in growth chambers at 10, 15, 20 or 25°C in darkness. Five random plants were removed from the chambers after each wetness period had passed. These plants were dried by placing them 90 cm apart from a slow-

speed fan, and then transferred to a growth chamber (20°C; 60% RH; 12h light/12h darkness) for disease development. After 30 days of incubation, disease incidence was assessed as the percentage of leaves with scab lesions per plant. Disease severity was assessed visually on each leaf as the percentage of the leaf area showing typical scab symptoms. The experiment was repeated once.

Data analyses. A homogeneity of variance test was performed for each experiment. A preliminary analysis of variance showed that there were no significant differences between repeated experiments, so that data from different experiments were pooled. Quantitative relationships between environmental variables and mycelial growth, conidial germination and infection were analyzed using regression analysis. Different linear and nonlinear regression models were fitted to the observed data; the equation parameters were estimated using the nonlinear regression procedure of SPSS (ver. 19.0, SPSS Inc., Chicago, USA) which minimizes the residual sums of squares using the Marquardt algorithm. The best model was chosen based on the adjusted R^2 , the number of iterations taken by the Marquardt algorithm to converge on parameter estimates, the magnitude of the standard error of the parameters, and the magnitude and distribution of the standardized residuals (Clewer and Scarisbrick, 2001). The goodness-of-fit was evaluated by considering the properties of the linear regression between real and estimated data (Teng, 1981) and by calculating the following indexes (Nash and Sutcliffe, 1970): the standard errors of the estimates (SEest), the root mean square error (RMSE) as the square root of the mean square error (RMSE represents the average distance of real data from the fitted line); and the coefficient of residual mass (CRM) as a measure of the tendency of the equation to overestimate or underestimate the observed values (a negative CRM indicates a tendency of the model toward overestimation). For the linear regressions each set of results, representing pairs of predicted and observed data, the null hypotheses that "a" (intercept of regression line) is equal to 0 and "b" (slope of regression line) is equal to 1 were tested using a t-test. If the t-tests for "a" and "b" were not significant, then both null hypotheses were accepted and the model was considered a statistically accurate predictor of the real data (Teng, 1981).

In the experiments where multiple isolates were used, the models were developed for each isolate and differences among isolates were evaluated based on the standard errors of the parameter estimates; since the confidence intervals of the estimated parameters of the different isolates always overlapped, the data from all isolates were pooled.

Results

Effect of temperature on mycelial growth. All isolates of *F. erobotryae* were able to growth between 5 to 25°C. High radial growth of the colony on PDA occurred between 15°C (average of 0.35 mm/day) and 25°C (0.36 mm/day), with a maximum at 20°C (0.49 mm/day); at 5 and 10°C the growth of the colonies was slower (0.05 and 0.19 mm/day, respectively). Any isolate was able to growth at 30 and 35°C, and the colonies dyed after one month at 35°C. The effect of temperature on mycelial growth was best described by the beta equation, in the form: $y = a \times Teq^b \times (1 - Teq)^c$; were: y is the relative growth of the colonies (calculated by dividing the growth rate at any temperature by that at the optimum temperature); a , b and c are the equation parameters; and Teq is an equivalent of temperature calculated as: $Teq = (T - T_{min}) / (T_{max} - T_{min})$ where: T is the temperature regime, and T_{min} and T_{max} are minimum and maximum temperatures, respectively, at which mycelium is able to growth. With $T_{min} = 0^\circ\text{C}$ and $T_{max} = 26^\circ\text{C}$, the beta equation fitted the data of single fungal isolates with R^2 between 0.87 and 0.99 (Table 3.1).

Curves for the different isolates had similar shape, as the values of the estimated parameters and their standard errors showed (Table 3.1). Therefore, the data for the different isolates were pooled in Equation 1 and the resulting equation had $R^2 = 0.98$, low standard error of the estimated parameters (Table 3.2), and the standard error of the estimates (SEest) = 0.05. The curve of relative growth increased between 0 to 20°C, had the maximum near 20°C and then quickly decreased (Fig. 3.1).

Effect of temperature and wetness duration on conidial germination. Conidia of *F. erobotryae* germinated at all temperatures tested. After 6h of wetness, germination occurred at 15, 20, 25 and 30°C, with the highest rate at 20°C (34.4%); at 5 and 10°C the germination started after 12 h of wetting. Irrespective of temperature, there was no increase in germination after 24 h of wetting. The maximum germination was observed at 20°C, with 60% of the conidia germinated. The best fit of the combined effect of temperature and wetness duration on conidial germination was obtained with the following model that combines a beta and a Gompertz equation (Equation 2 in Table 3.1 and Fig. 3.2), as follows: $y = a \times Teq^b \times (1 - Teq)^c \times \exp(d \times \exp(e \times WD))$, in which: y is relative conidial germination referred to the maximum germination observed; Teq it is the equivalent of temperature calculated as described before; WD is the wetness duration (in hours); and a , b , c , d and e are the equation parameters. The equation for pooled data had $R^2 = 0.93$; standard errors of the equation parameter

were low compared to the parameter values, except for parameters a and e (Equation 2 in Table 3.1). However, the regression of estimated versus observed data had slope not significantly different from 1, and intercept was different from 0 at $P=0.02$ (Fig. 3.3). The CRM was -0.013, which showed a small over-estimation of real germination, RMSE was 0.088 and SEest was 0.086. The model showed an increase of the germination rate of *F. eriobotryae* between 0 and 20°C, and then a decrease at higher temperatures, with $T_{\max}=35^{\circ}\text{C}$. Irrespective of temperature, germination increased with wetness duration until 18 hours (Fig.3.2).

Effect of relative humidity on conidial germination. Compared to germination in free water, germination at 100% RH was reduced by a 24.9% on average. At 100% RH, less than 10% of the conidia germinated, except for 20°C and 36 h of incubation (14.1%). Germination at RH between 81% and 99% was lower than 2% for all temperatures and incubation periods tested, also at the optimum temperature of 20°C.

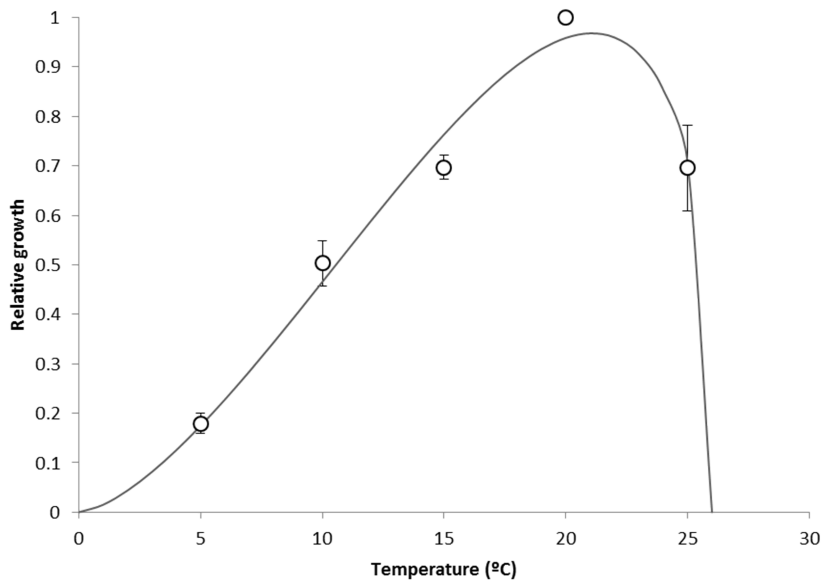

Figure 3.1. Relationship between temperature and relative growth of *Fusicladium eriobotryae* mycelium as predicted by Equation 1 of Table 3.1. Symbols represent observed data and whiskers are the standard errors calculated over different experiments and fungal isolates. Relative growth is calculated by dividing growth (mm/day) in each observation by the maximum growth at optimum temperature.

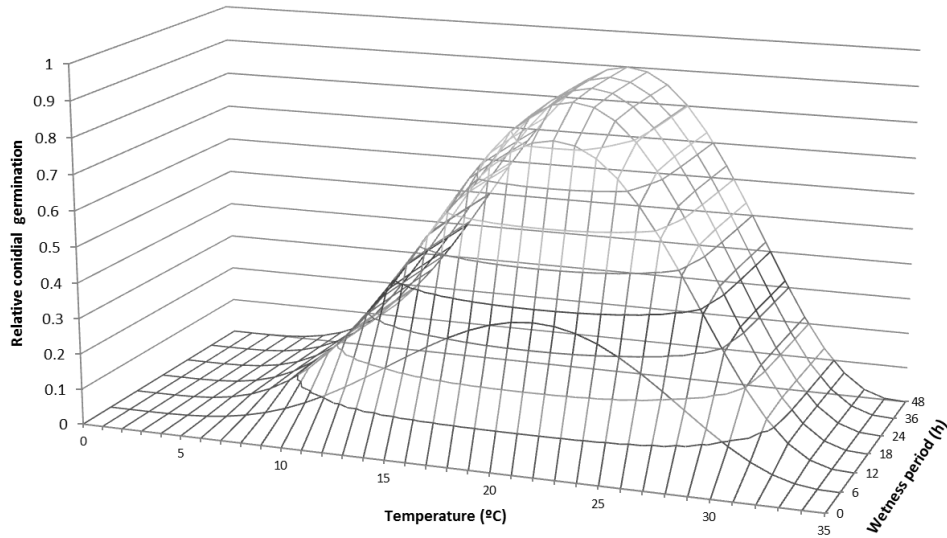

Figure 3.2. Relationship between temperature, wetness duration and relative germination of conidia of *Fusicladium erobotryae* as predicted by Equation 2 of Table 3.1. Relative conidial germination is calculated by dividing percentage of germinated conidia in each observation by the maximum germination found in each experiment.

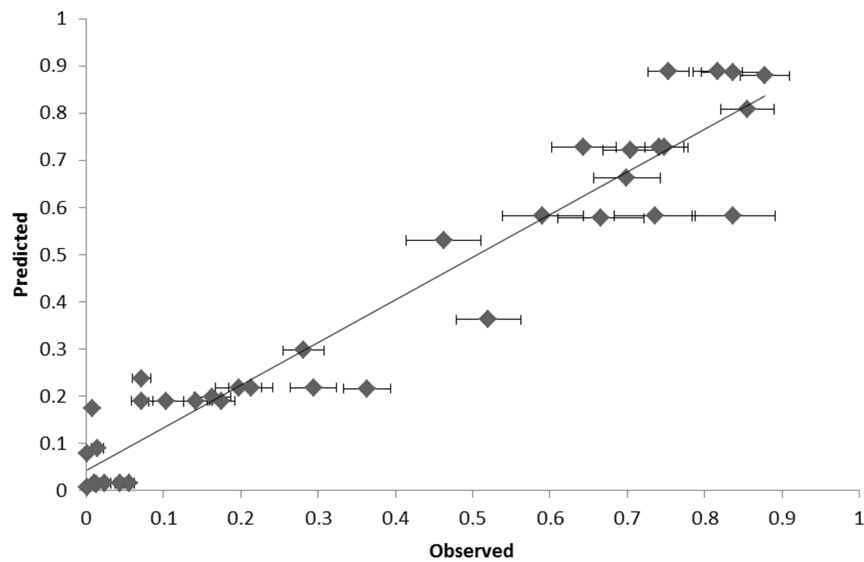

Figure 3.3. Predicted versus observed data on relative germination of *Fusicladium erobotryae* conidia. Data are predicted by Equation 2 of Table 3.1. Whiskers are the standard errors calculated over different experiments and fungal isolates.

Table 3.1. Equations used to fit data on mycelial growth (1), conidial germination (2), effect of dry period on conidial germination (3), disease incidence (4) and severity (5) of *Fusicladium eriobotryae* as a function of environmental variables.

Equation ^a	T_{min}/T_{max} ^b	Estimated parameters ^c					R^2	Figure ^d
		<i>a</i>	<i>b</i>	<i>c</i>	<i>d</i>	<i>e</i>		
1: $y=a \times Teq^b \times (1-Teq)^c$	0/ 26	2.460 (0.501)	1.557 (0.236)	0.364 (0.076)	-	-	0.98	3.1
2: $y=a \times Teq^b \times (1-Teq)^c \times \exp(d \times \exp(e \times WD))$	0/ 35	116.249 (59.597)	4.347 (0.435)	2.882 (0.299)	8.550 (8.620)	0.376 (0.161)	0.93	3.2
3: $y=a \times \ln(DP)+b$	-	-0.165 (0.015)	0.879 (0.048)	-	-	-	0.98	3.4
4: $y=a \times Teq^b \times (1-Teq)^c \times \exp(d \times \exp(e \times WD))$	0/ 25	4.961 (2.944)	1.700 (0.527)	0.771 (0.310)	4.704 (1.381)	0.087 (0.018)	0.94	3.6
5: $y=a \times Teq^b \times (1-Teq)^c \times \exp(d \times \exp(e \times WD))$	0/ 25	7.574 (7.629)	2.841 (0.962)	0.769 (0.493)	4.324 (1.048)	0.050 (0.015)	0.93	3.7

^a Teq = equivalent of temperature calculated as: $Teq=(T-T_{min})/(T_{max}-T_{min})$; WD =wetness duration (in hours); DP =duration of the dry period between two wet periods (in hours).

^b T_{min} and T_{max} =minimum and maximum temperature used to calculate Teq .

^c Equation parameters were estimated for the data pooled over the different fungal isolates and repeated experiments; standard errors of the estimated parameters in brackets.

^d Reference to figures.

Table 3.2. Parameter estimates and summary statistics of nonlinear regression analysis relating the relative growth of *Fusicladium eriobotryae* at different temperatures.

Parameter ^a	a		b		c		R ²	
	Isolate	Estimate	SE ^b	Estimate	SE	Estimate		SE
FE-3		1.612	0.698	1.100	0.740	0.179	0.156	0.87
FE-6		2.629	0.469	1.497	0.198	0.414	0.069	0.98
FE-17		1.837	0.602	1.218	0.364	0.220	0.118	0.93
FE-31		6.916	3.026	2.429	0.471	0.930	0.201	0.97
FE-36		1.885	0.457	1.391	0.286	0.218	0.085	0.97
FE-40		3.760	0.477	2.29	0.170	0.487	0.045	0.99

^a Regression equation is $y = a \times Teq^b \times (1 - Teq)^c$; where: y is the relative growth of the colonies (calculated by dividing the growth rate at any temperature by that at the optimum temperature); a , b and c are the equation parameters; and Teq is an equivalent of temperature calculated as: $Teq = (T - T_{min}) / (T_{max} - T_{min})$ where: T is the temperature regime, and $T_{min} = 0^\circ\text{C}$ and $T_{max} = 26^\circ\text{C}$.

^b SE is the standard error of each parameter

Effect of dry periods on conidial germination. The germination of *F. eriobotryae* conidia diminished as the duration of the dry period between two wetness periods increased. When the initial wetness period was 6-hour long, the germination decreased from 17.6% (0 hours of dry period) to 2.9% (72 hours of dry period) at 20% RH during the dry period; germination decreased to 8.8% at 60% RH. When the initial wetness period was 12-hour long, the germination decreased from 27.3% to 4.1% at 20% RH during the dry period, and to 5.2% at 60% RH. The overall effect of dryness on germination was described by a logarithmic equation (Equation 3 in Table 3.1 and Fig. 3.4) in the form: $y = a \times \ln(DP) + b$, where: y is the relative germination rate referred to the maximum observed; a and b are the equation parameters; and DP is the duration of the dry period between two wet periods (in hours). The equation fitted the data with $R^2 = 0.98$; standard errors for the estimated parameters were low (Equation 3 in Table 3.1). The germination curve continuously decreased as the length of dry period increased, with 50% of reduction in the first 10 h of dryness (Fig. 3.4).

Effect of temperature and wetness duration on leaves infection. *F. eriobotryae* conidia caused infection at temperatures between 10 and 20°C. No infection was observed at 25°C. At 10, 15 and 20°C, infection occurred with minimum 12 h of wetness; both disease incidence and severity increased as the wetness duration increased. Disease incidence (percentage of leaves with scab lesions) was 28.3% and 30.0% after 18 h of wetness at 15 and 20°C,

respectively; incidence was 53.0% and 55.0% after 60 hours for the two temperatures, respectively (Fig. 3.5 A). At 10°C, only 3.3% of leaves were infected after 18 hours and 37.7% after 60 hours. Disease severity (percentage of leaf area with scab lesions) showed a similar trend, with 30.7% and 31.9% after 60 hours of wetness at 15 and 20°C, respectively (Fig. 3.5 B). At 10°C, disease severity after 60 hours of wetness was 17.4%.

The effect of temperature and wetness duration on either disease incidence or severity was described by the combination of beta and Gompertz equations in the form described for conidial germination (Equation 4 and 5 in Table 3.1 and Fig. 3.6 and 3.7). For disease incidence and severity, the model provides $R^2=0.942$ and 0.931 , respectively (Equation 4 and 5 in Table 3.1).

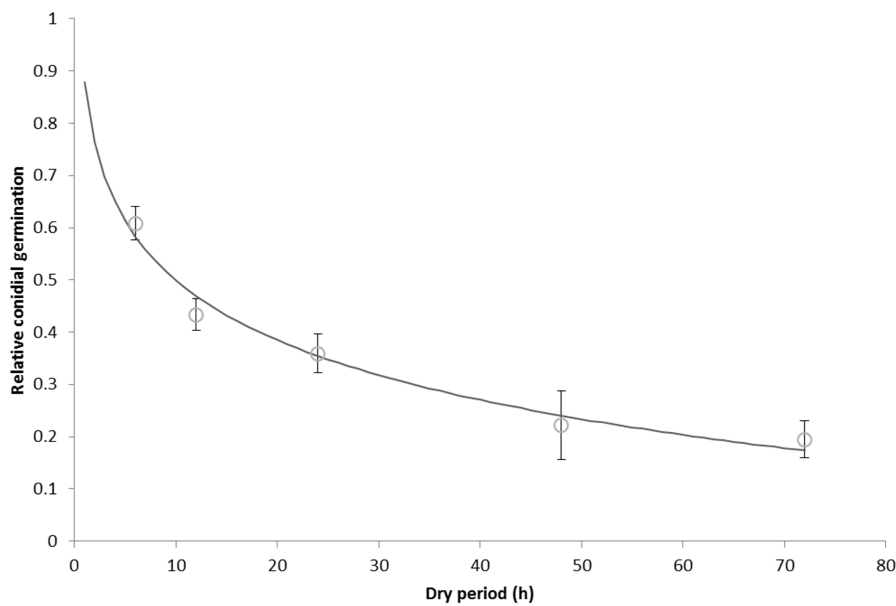

Figure 3.4. Relationship between length of dry periods and relative germination of *Fusicladium eriobotryae* conidia as predicted by Equation 3 of Table 3.1. Symbols represent observed data and whiskers are the standard errors calculated over different experiments and fungal isolates. Relative conidial germination is calculated by dividing percentage of germinated conidia in each observation by the maximum germination found in each experiment

The regression equations of estimated versus observed data had slopes and intercepts no significantly different from 1 and 0, respectively. Moreover, SEest was 0.085 for incidence and 0.073 for severity, and root mean standard error was 0.007 for incidence and 0.006 for severity. However, CRM was negative in both cases (-0.019 for incidence and -0.033 for severity), which express the tendency of the equations to overestimate the infection. The model developed showed as, in both cases, the relative percentage of affected leaves increased with temperature and wetness duration (Fig. 3.6 and 3.7). The lag phase was longer for disease severity than incidence, but maximum values of incidence and severity occurred at the same conditions, i.e., 60 hours of wetness at 20°C.

Discussion

This is the first published study that investigates the effect of environmental factors on mycelial growth and conidial germination of *F. eriobotryae*, and on the ability of the pathogen to infect loquat leaves. These results increase the current knowledge of the epidemiology of this pathogen and of its life cycle, which are both essential steps to develop a disease prediction system.

Mycelium of *F. eriobotryae* was able to grow, and conidia to germinate, in a wide range of temperatures. Temperature requirements obtained are similar to that of other pathogens in the genus *Venturia*, such as *V. inaequalis* (Boric, 1985), *V. nashicola* (Li *et al.*, 2003), *F. carpophilum* (Lawrence and Zehr, 1982) and *F. oleagineum* (Obanor *et al.*, 2008b). *F. carpophilum* showed, as *F. eriobotryae*, a slow growth at 10°C and low percentage of germination at 15°C (Lawrence and Zehr, 1982). However, for *V. inaequalis*, *V. nashicola* and *F. oleagineum*, the rate of germination was higher at low temperatures compared to *F. eriobotryae*. For *V. inaequalis* and *V. nashicola*, almost all the conidia germinated at 10°C, and 50% of them at 5°C (Boric, 1985; Li *et al.*, 2003); 40% of *F. oleagineum* conidia germinated at both temperatures but no germination occurred at 30°C (Obanor *et al.*, 2008b). In general, in the above pathogens, temperature has no decisive influence on the germination of conidia because high germination is achieved within a wide range of temperatures (5-30°C). In this work, the temperature range is similar, although more conidia germinated and the mycelium grew faster between 15 and 25°C, indicating that the temperature range for optimal development of *F. eriobotryae* is narrower, as in the case of *F. carpophilum* (Lawrence and Zehr, 1982).

Conidial germination of *F. eriobotryae* was strongly influenced by moisture and substantial germination occurred only in free water. Obanor *et al.*

(2008b) observed that conidia of *F. oleagineum* did not germinate after 48 h of incubation at 60 and 80% RH. No germination of conidia of *F. carpophilum*, *V. inaequalis* and *V. nashicola* was observed when they were incubated with less than 98% RH (Li *et al.*, 2003; MacHardy, 1996), but germination occurred between 98% and 100% RH, showing that these pathogens are able to germinate in the absence of free water.

Conidia germinated after 6 h of continuous wetness between 15 and 30°C, and after 12 h at 5 and 10°C. These wetness requirements were slightly different than those reported for *V. inaequalis* (Boric, 1985) and *V. nashicola* (Li *et al.*, 2003), in which 5 h of continuous wetness were enough for germination at 5°C and 30°C, and 2 h for germination at 15 to 25°C. In the case of *F. oleagineum*, conidial germination required 24 h of wetness at 5°C, and 9 h at 20°C (Obanor *et al.*, 2008b). For all these pathogens, conidial germination increased with increasing wetness duration (Boric, 1985; Li *et al.*, 2003; Obanor *et al.*, 2008b); for *F. eriobotryae*, no increase in germination occurred after 24 h of wetness, regardless of the temperature.

Conidia of *F. eriobotryae* were susceptible to dry periods interrupting two wet periods. Li *et al.* (2005) reported a 70% of mortality of conidia of *V. nashicola* after 10 hours of dryness at high temperatures (28°C) and a reduction of 40% at 20°C. Also conidia of *F. oleagineum* and *V. pyrina* were affected by dryness. In the former fungus, a reduction of 50% in the number of lesions in olive leaves which have been inoculated with conidia was observed after 10 h of dryness and no lesions developed after 24 h (70% RH during the dry period) (Obanor *et al.*, 2010). In the case of *V. pyrina*, no lesions developed when inoculated leaves remained dry for more than 12 h at RH<70% (Villalta *et al.*, 2000a). On the contrary, Becker and Burr (1994) reported that, in the case of *V. inaequalis*, the viability of ungerminated conidia was not affected by exposure to a dry period of less than 24 h, regardless of the RH level (60% and >90%), and decreased only slightly after 96 h of dryness.

The infection of loquat leaves by *F. eriobotryae* was influenced by both temperature and wetness duration. The minimal wetness period required for infection (12 h) is in agreement with that observed for *F. oleagineum* (Obanor *et al.*, 2010; Viruega *et al.*, 2011), while for *V. inaequalis*, *V. nashicola* and *V. pyrina*, at the optimal temperature of 20°C, scab symptoms appeared after 6, 9 and 9 h, respectively (Spotts and Cervantes, 1991; Hartman *et al.*, 1999; Villalta *et al.*, 2000b; Li *et al.*, 2005). *F. effusum* showed infection after 2 h of wetness at temperatures of 10 and 15°C, but needed 9 h of wetness for 20 to 30°C (Lawrence and Zehr, 1982).

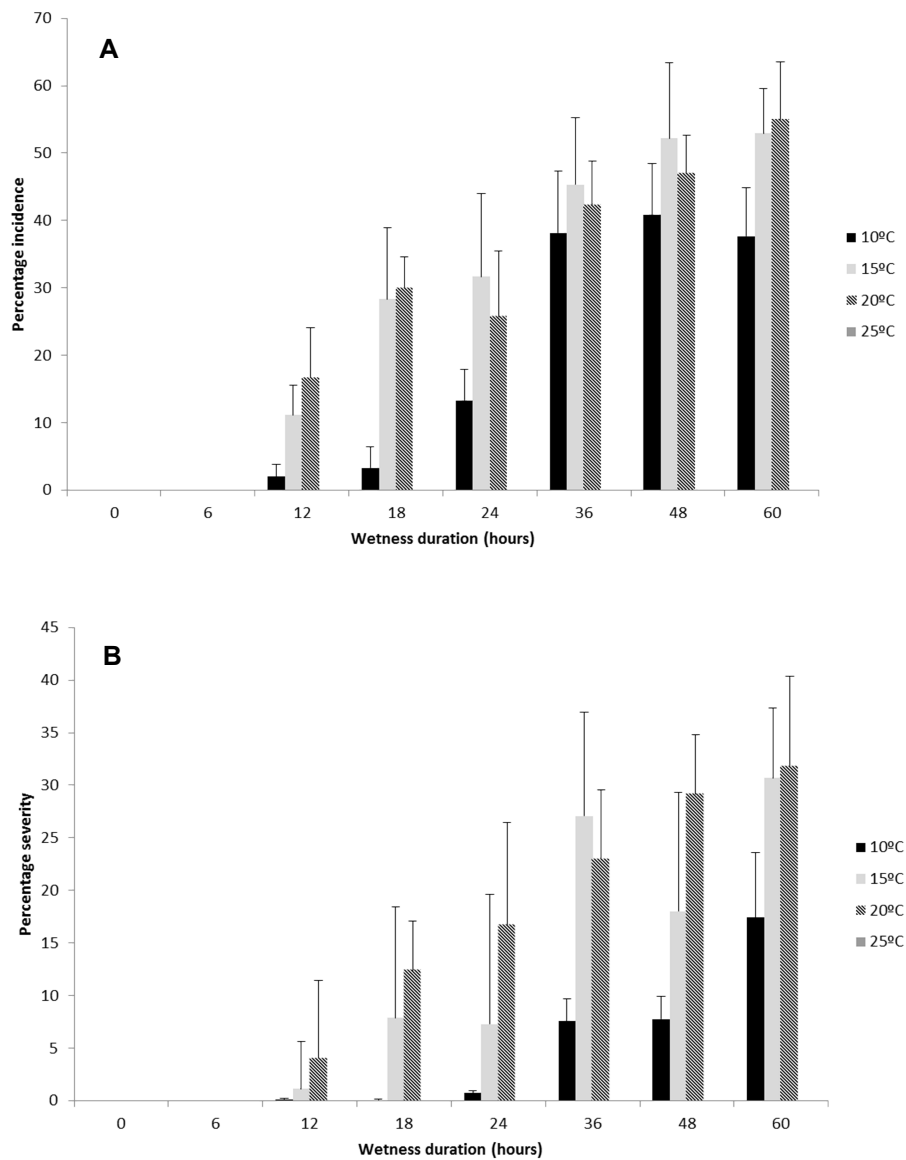

Figure 3.5. Effect of temperature and wetness duration on scab incidence (**A**) and severity (**B**) in loquat leaves inoculated with *Fusicladium eriobotryae*. Each column represents the mean disease incidence of two experiments with five replicate plants each. Incidence was assessed as the percentage of leaves with scab lesions per plant and severity as the percentage of leaf area with scab lesions. Whiskers represent the standard error.

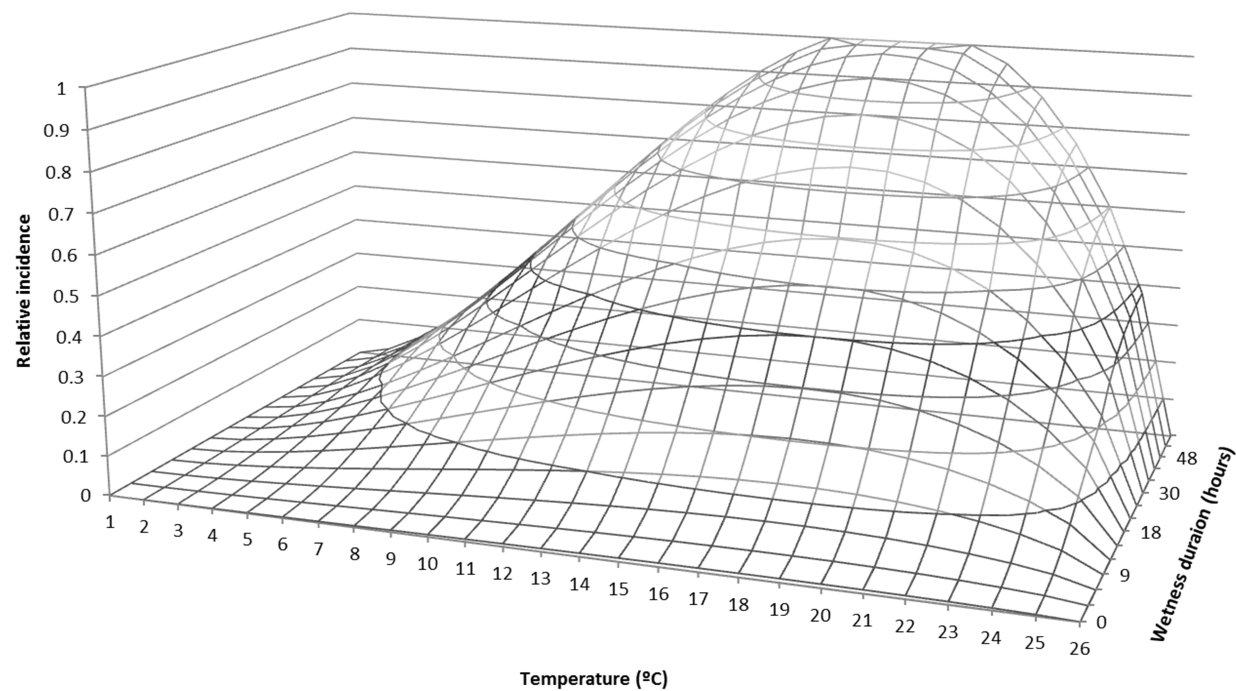

Figure 3.6. Relationship between temperature, wetness duration and relative scab incidence of *Fusicladium eriobotryae* on loquat leaves as predicted by Equation 4 of Table 3.1. Relative disease incidence is calculated by dividing incidence for each plant by the maximum incidence found in the experiment.

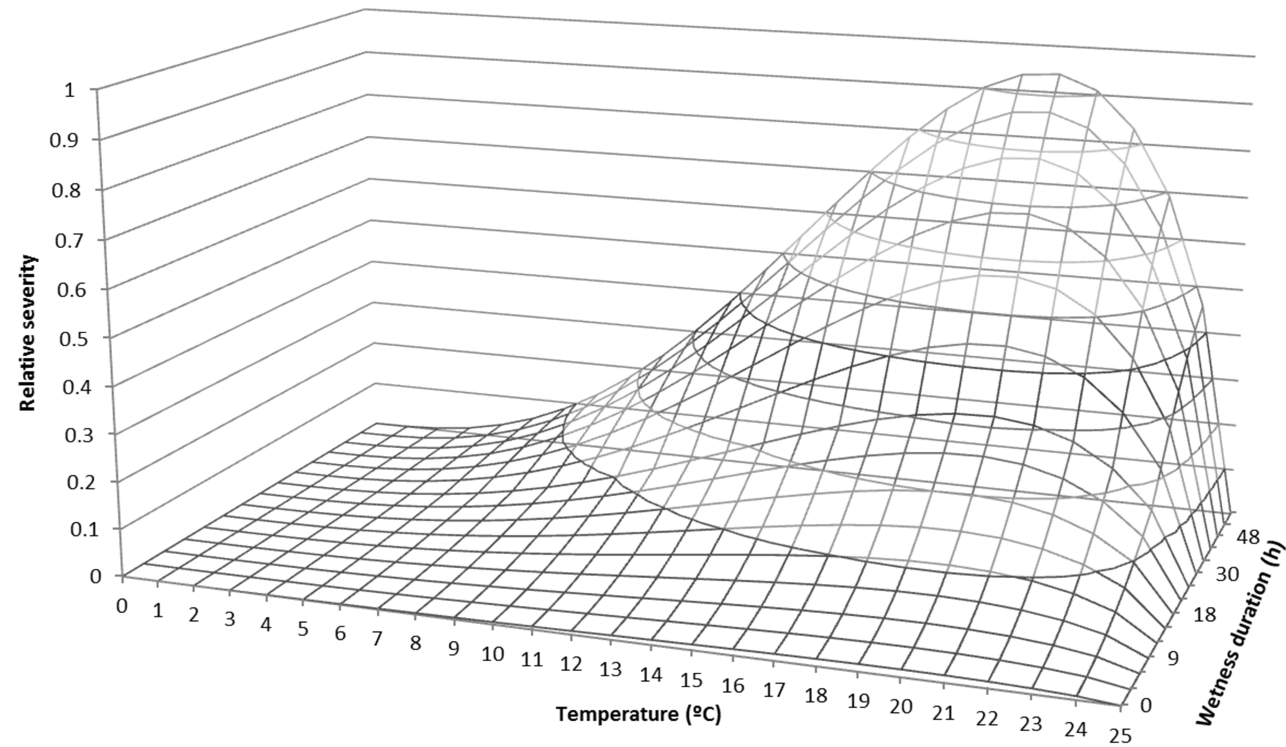

Figure 3.7. Relationship between temperature, wetness duration and relative scab severity of *Fusicladium eriobotryae* on loquat leaves as predicted by Equation 5 of Table 3.1. Relative disease severity is calculated by dividing percentage of severity for each plant by the maximum severity found in the experiment.

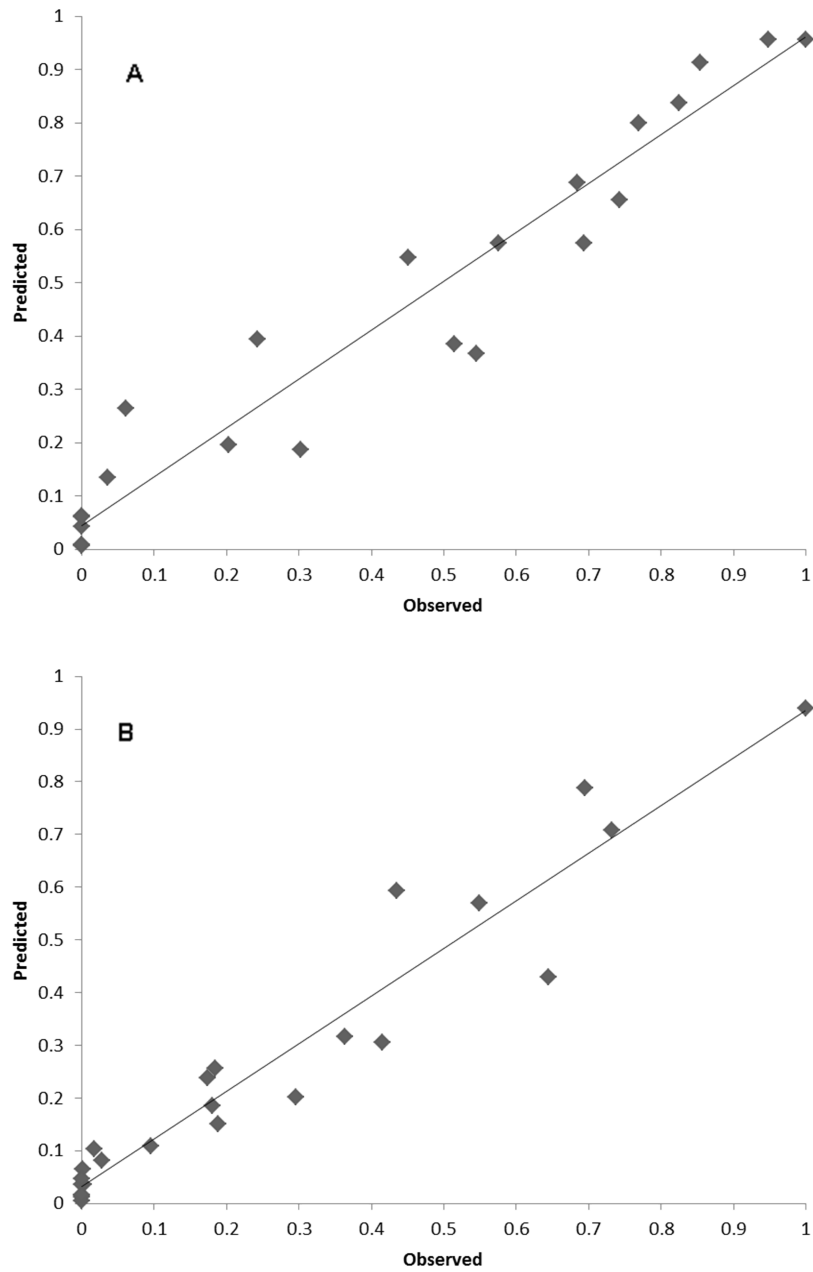

Figure 3.8. Predicted versus observed data on relative incidence (A) and severity (B) of *Fusicladium eriobotryae* infection on loquat leaves. Data are predicted by Equation 4 and 5 of Table 3.1, respectively.

For all the above pathogens different from *F. eriobotryae*, symptoms developed also at 25°C. In *F. eriobotryae*, the increase of leaf wetness duration resulted in higher disease incidence and severity of loquat scab until 60 h of wetness. Also for *F. effusum*, *F. oleagineum* and *V. nashicola* the development of scab symptoms increased until 48, 96 and 50 h of wetness, respectively (Gottwald, 1985; Li *et al.*, 2005; Obanor *et al.*, 2010, Viruega *et al.*, 2011). Hartman *et al.* (1999) and Villalta *et al.* (2000b) reported, at the optimal temperature of 20°C, no increase in scab development after 14 and 30 h of wetness for *V. inaequalis* and *V. pyrina*, respectively.

The results obtained in this study indicate that mild temperatures and long wet periods are necessary for loquat scab infection to occur. Moreover, viability of conidia is substantially reduced by dry periods. In the Mediterranean areas where loquat is grown, temperature seems not a limiting factor for the disease in late fall and spring, as medium values range between 15 and 25°C (IVIA, 2012). On the contrary, moisture might be the limiting factor for infection by *F. eriobotryae*; for instance, only six periods with more than 60 h of interrupted wetness occurred in the loquat production area of the Comunidad Valenciana (eastern Spain) in the 2011-2012 period (IVIA, 2012).

The information obtained in this study shows that *F. eriobotryae* has similar temperature and moisture requirements of *F. oleagineum*, causal agent of olive scab, and another pathogen of Mediterranean crops (Obanor *et al.*, 2008b; Obanor *et al.*, 2010; Viruega *et al.*, 2011). On the contrary, *F. eriobotryae* has shown substantial differences in comparison to other Venturiaceae that affect crops from different climatic zones, such as apple (*V. inaequalis*), pear (*V. nashicola* and *V. pyrina*) or pecan (*F. effusum*). In the latter pathogens, the germination rate of conidia was higher at low temperatures (5-15°C) and the wetness requirement for germination to start or infection to occur was shorter (2-6 h) (Gottwald, 1985; Spotts and Cervantes, 1991; Hartman *et al.*, 1999; Villalta *et al.*, 2000b). Moreover, conidia of *V. inaequalis* and *V. nashicola* were able to germinate also in the absence of free water (MacHardy, 1996; Li *et al.*, 2003).

In the main loquat cultivation areas of Spain, the regional plant health services use the Mills-Laplante tables (Mills and Laplante, 1954) to estimate the risk of infection by *F. eriobotryae* (GVA, 2013). These tables have been developed to control apple scab (MacHardy, 1996) and have been used for other diseases such as pear scab (Villalta *et al.*, 2000b) and grape powdery mildew (Thomas *et al.*, 1994). This work has shown that conidia of *F. eriobotryae* require longer times for leaf infection to occur than those described by the Mills-Laplante tables for *V. inaequalis*, and the temperature range in which infection occurs is

quite different. Therefore, the Mills-Laplante criterion might lead to an overestimation of the infection periods of *F. eriobotryae* and, consequently, to unjustified alarms provided to growers, which might result in unnecessary spray of fungicides. Therefore, to improve the accuracy and robustness of infection period estimation for *F. eriobotryae*, specific equations need to be developed and used in the control of loquat scab.

In the present research, equations which describe the growth, germination and infection of *F. eriobotryae* at different weather conditions have been developed, which provided a reasonable fit of the biological processes investigated, as demonstrated by the goodness-of-fit. The equations were firstly fit to individual fungal isolates; after analyzing the equation parameter estimates for the different strains and their confidence intervals, the data of all strains were pooled in a unique equation. Therefore, the equation parameters estimated for the pooled data were consistent over the different isolates and the equation are supposed to estimate the epidemiological parameters of *F. eriobotryae* robustly, irrespective of the strains (Mwakutuya and Banniza, 2010; Villalta *et al.*, 2000a; Obanor *et al.*, 2008b, 2010; Viruega *et al.*, 2011). The possibility of using these equations to predict scab occurrence in field needs to be tested in further experiments.

The equations developed in this work could be further integrated in a disease prediction system for scheduling fungicide sprays against loquat scab. In order to develop a comprehensive loquat scab prediction model, further studies are necessary. In particular, information on factors influencing production and dispersal of *F. eriobotryae* conidia and on changes of fruit susceptibility at different growth stages is required. This is currently under investigation.

Acknowledgements

This work was funded by Cooperativa Agrícola de Callosa d'En Sarrià (Alicante, Spain). Financial support by the Programa de Apoyo a la Investigación y Desarrollo (PAID-00-12) de la Universidad Politécnica de Valencia for E. González-Domínguez during her three months stay at the Università Cattolica del Sacro Cuore (Piacenza, Italy) is gratefully acknowledged. We would like to thank E. Soler for his technical assistance.

Chapter 4

Dispersal of conidia of *Fusicladium eriobotryae* and spatial patterns of scab in loquat orchards in Spain

Elisa González-Domínguez¹, Vittorio Rossi², Sami Jorge Michereff³, José García-Jiménez¹ and Josep Armengol¹ (2014). European Journal of Plant Pathology. In press.

¹Instituto Agroforestal Mediterráneo, Universidad Politécnica de Valencia, Camino de Vera s/n, 46022-Valencia, Spain.

²Istituto di Entomologia e Patologia vegetale, Università Cattolica del Sacro Cuore, 29122 Piacenza, Italy.

³Departamento de Fitossanidade, Faculdade de Agronomia, Universidade Federal do Rio Grande do Sul, 91540-000 Porto Alegre, RS, Brazil.

Abstract

Dispersal of conidia of *Fusicladium eriobotryae*, the causal agent of loquat scab, was investigated in two loquat orchards in Spain from 2010 to 2012. A volumetric spore sampler, horizontally and vertically orientated microscope slides, and rain collectors were placed in loquat fields to trap conidia of *F. eriobotryae*. No conidia were collected in the volumetric sampler, and highly variable numbers of conidia were collected in the rain gatherers. Large numbers of conidia were collected by microscope slides, particularly by those held in a horizontal orientation compared with those held in a vertical orientation. Approximately 90% of the *F. eriobotryae* conidia were collected during rainy periods. Based on ROC and Bayesian analysis, using ≥ 0.2 mm rainfall as a cut-off value resulted in a high probability of correctly predicting actual conidial dispersal, and had a low probability of failing to predict actual conidial dispersal. Based on the index of dispersion and the binary power law, the incidence of loquat scab on fruit was highly aggregated in space between and within trees, and aggregation was influenced by disease incidence. Our results demonstrate, for the first time, that *F. eriobotryae* is dispersed mainly in rain splash. The results will be integrated into a mechanistic, weather-driven, disease prediction model that should help growers to minimize fungicide application for the management of loquat scab.

Introduction

Fusicladium eriobotryae (Cav.) Sacc. is the causal agent of loquat scab, which is the major disease of loquat in the Mediterranean basin. The disease causes damage to fruit and leaves; young twigs can also be affected when the disease is severe (Sánchez-Torres *et al.*, 2009; Gladieux *et al.*, 2010). Hyphae of *F. eriobotryae* grow subcuticularly, and the infection first appears as circular chlorotic spots, which become olive-colored and velvety as they increase in size (Sánchez-Torres *et al.*, 2007b; Sánchez-Torres *et al.*, 2009). Scabby fruits are unsuitable for sale, resulting in significant economic losses (Sánchez-Torres *et al.*, 2009).

Previous studies have elucidated some of the salient points pertinent to the biology and epidemiology of *F. eriobotryae* (Salerno *et al.*, 1971a; Raabe and Gadner, 1972; Sánchez-Torres *et al.*, 2009; González-Domínguez *et al.*, 2013b) but there is no formal description of the disease cycle available (Ogawa and English, 1991). The sexual stage of *F. eriobotryae* has not been found (Gladieux *et al.*, 2010). The asexual conidia of *F. eriobotryae* are abundant on lesions on leaves and even more abundant on fruits (Sánchez-Torres *et al.*, 2007b). Hyphae are able to grow and conidia are able to germinate over a wide range of temperature but conidia do not germinate at relative humidity (RH)<100%. Conidia cause infection between 10 and 20°C, and disease incidence and severity increase as the duration of the wetness period increases (González-Domínguez *et al.*, 2013b). Salerno *et al.* (1971a), indicated that in Sicily, leaf infection occurred in autumn and spring and fruit infection in winter and spring, and they suggested that rain could play a role in conidial dispersal.

Fungal spores may be dispersed in air currents, rain splash, aerosols, and by insect vectors (Campbell and Madden, 1990). The method of spore dispersal influences disease development in time and space; and the timing of spore release can affect disease management (Meredith, 1973). Wind-mediated dispersal determines the long-range movement of spores, whereas splash dispersal is important in dispersal within or between neighboring plants/trees (Meredith, 1973). In orchards, the effect of splash dispersal of spores on disease progress can be partially inferred from the spatial pattern of diseased fruit in the tree (Spósito *et al.*, 2008). The level of aggregation of diseased fruit in the canopy, under similar environmental conditions, depends on the distance from the inoculum source and the pathogen dispersal mechanism. A high degree of disease aggregation occurs when the pathogen is dispersed only short distances, and splash-borne spores are usually dispersed short distances, resulting in a steeper dispersal gradient compared with the dispersal gradient observed for wind-borne spores (Meredith, 1973; Fitt *et al.*, 1989), and leading to

a greater degree of disease aggregation. The nature of pathogen dispersal may also be reflected in the location of the diseased fruit in the tree canopy. Thus, the presence of diseased fruits in the upper part of the tree canopy would suggest infection by airborne spores, whereas diseased fruits in the lower part of the canopy may have been infected either by airborne or splash-borne spores (Kiely, 1948; Meredith, 1973; Kotzé, 1981; Carisse *et al.*, 2006).

Species of *Fusicladium* are dispersed in both wind and rain splash. Conidia of *Venturia inaequalis* are released by rain and dispersed in splash moving under the influence of wind and gravity; only strong air currents were able to dislodge conidia from dry sporulating lesions (Frey and Keitt, 1925). However, Sutton *et al.* (1976) documented substantial aerial dissemination of *V. inaequalis* conidia during spring and summer, particularly in periods without rain. Conidia of *F. oleagineum* are dispersed mainly by rain, but limited wind dissemination also occurs in the absence of rain, if RH is high (Lops *et al.*, 1993). Conidia of *F. effusum* are dispersed in air currents after rainfall, with localized dispersal occurring through rain splash (Gottwald and Bertrand, 1982; Latham, 1982; Gottwald, 1983), while those of *F. carpophilum* are dispersed predominantly in rain splash (Lan and Scherm, 2003; Scherm *et al.*, 2008).

Currently the apple scab infection model developed by Mills and Laplante (1954) is used to guide fungicide application for management of loquat scab in Spain. Information on the weather conditions conducive specifically to dispersal of *F. erobotryae* and the resulting distribution of scab is crucial to developing an improved disease-specific model to manage loquat scab. In pursuit of this aim, the objectives of this study were to (i) describe the dispersal of *F. erobotryae* conidia in relation to weather conditions and (ii) evaluate the spatial pattern of scab in loquat orchards.

Materials and methods

Orchard sites. A 3-year study (2010–2012) was carried out in two loquat orchards in Callosa d'En Sarrià, Alicante province, southeastern Spain. Both orchards were planted with cv. *Algerie* in 2.5-m-wide terraces and tree spacing 3.5 m. Orchard A (located at 38°39'06"N, 0°6'15"W) was 20 years old, occupied 0.49 ha, and was drip irrigated (two drippers per tree). Prior to October 2010, loquat scab in orchard A was managed using fungicides following the recommendations of the regional plant health services (GVA, 2013). After October 2010 and during the study, orchard A received no fungicides to manage scab, but otherwise received standard cultural practice. Orchard B (located at 38°39'50"N, 0°6'50"W) was 25 years old, occupied 0.32 ha, and had been

abandoned in 2005. Thus, no crop management or fungicide sprays had been applied to orchard B since 2005. None were applied during the current study.

Air temperature (T, °C), RH (%), total rainfall (R, mm), and leaf wetness duration (WD, hours) were registered every 30 min using a weather station (Regional Agrometeorological Service, <http://riegos.ivia.es/>) located in orchard A (3.5 km of orchard B). The weather station was 1.5 m above the ground, and the leaf wetness sensor faced north at a 30-degree angle.

Spore dispersal monitoring. Three types of spore samplers were used: i) a Burkard 7-day recording volumetric spore sampler (Burkard Manufacturing Co., Rickmansworth, Hertfordshire, UK); ii) microscope slides coated with silicone grease (slide samplers); and iii) rain collectors.

The Burkard spore sampler was placed in the center of orchard A and was operated continuously from 8 February 2010 to 20 June 2011. The orifice for sampling the air flow was approximately 0.30 m above the ground, and had a sampling rate of 10 L air/min. Conidia drawn into the sampler impacted plastic tape coated with silicone grease (Lanzoni srl, Bologna, Italy). Tapes were removed weekly, cut into 48-mm lengths (24 h intervals) stained with glicerogelatine (7.5 g of gelatine, 50 ml de glycerol and 42.5 ml of distilled water), mounted on glass slides under 22×50 mm coverslips, and sealed. Slides were scanned under a compound microscope at 40× to identify and enumerate the *F. eriobotryae* conidia on an hourly basis (Sánchez-Torres *et al.*, 2007b).

Microscope slides (75×25 mm) covered with a tape (48×14 mm) that was treated with silicone (Lanzoni S.R.L., Bologna, Italy) were exposed in the two orchards during the two seasons (7 February to 20 June in 2011 and 8 December 2011 to 10 May in 2012, the period from fruit set to fruit harvest). The slides were replaced at weekly intervals at 11:00 am, and were exposed for 23 and 21 sampling periods in 2011 and 2012, respectively. Slides were oriented both horizontally and vertically, with three randomly located replicates of horizontal and vertical samplers in each orchard. Horizontal samplers were placed under the tree canopy at 1.30 m above the ground. Each horizontal sampler consisted of two microscope slides secured to both sides to a wooden board (20×15 cm). Vertical samplers were placed between the tree canopies at 1.60 m above the ground. Each vertical sampler consisted of four microscope slides oriented in the four cardinal directions; the upper and lower edges of each slide were inserted into slots of two polystyrene sheets; the tops of the vertical slides were covered by a horizontally-oriented Petri dish to prevent the surface being washed by rain. Horizontal and vertical spore samplers were supported by a metal stake driven into the ground. For both kinds of slide traps, *F. eriobotryae*

conidia were counted using a compound microscope at 40×; four equidistant transects were made across the long axis of each slide, the conidia were enumerated and counts expressed as number of conidia per cm² of sampler surface over the period of exposure.

Rain collectors (three per orchard) were exposed under the tree canopy at 1.6 m above the ground and near the horizontal slide samplers. Collectors were deployed on the same dates as the slide traps and were replaced weekly. Each rain collector consisted of a 330-ml plastic collection bottle into which was inserted a plastic funnel (15 cm diameter). Each bottle contained 10 ml of water containing 10 mg/L of didecyl dimethyl ammonium chloride (Sporekill, ICA International Chemicals Pty. Ltd., Stellenbosch, South Africa) to prevent conidia germination. Once removed from the field the bottles were left undisturbed for 2 days (at room temperature) to allow the conidia to settle, when the bottles were perforated 20 mm above the base to permit most of the water to drain, leaving about 30 ml in the bottle. This 30-ml sample was centrifuged at 5000 rpm at 15°C for 15 min; the supernatant was discarded, and the pellet was resuspended in 5 ml of distilled water and conidia quantified using a hemacytometer (six fields examined per sample). Concentration was expressed as conidia per ml of rain measured by the weather station. Both the drained water and the supernatant were checked for the presence of conidia, but no conidia were found.

Disease assessment. Scab incidence on fruit of 46 trees in five rows in orchard A was assessed weekly from 14 February to 16 May 2011 and from 5 January to 12 April 2012. In each tree, four shoots (with four loquat fruit per shoot) were randomly tagged, one from each quadrant of the tree. Fruit on the tagged shoots were classified as healthy or diseased; a fruit was considered to be diseased if at least one visible scab lesion was present on its surface. Disease incidence was expressed as a percentage (diseased fruit over total fruit ×100).

Data analyses. Counts of conidia from horizontal and vertical slide samplers were used to calculate the degree of association between the occurrence of a rain event in a sampling period and (i) the occurrence of positive spore sampling in the period (i.e., at least one conidium caught over the period) and (ii) the number of conidia collected over the period.

During the period when the slide samplers were in the orchards, a rain event was defined as having occurred depending on the following five thresholds or “cut-off” values: ≥0.2 mm, ≥0.5 mm, ≥1 mm, ≥3 mm, and ≥5 mm. For each level, contingency tables (2×2) were prepared with the following cells: the true positive proportion (TPP or sensitivity), which was the number of periods when

conidia were collected and it rained ÷ the total number of periods when conidia were collected; the false negative proportion (FNP), which was the proportion of periods when conidia were collected but there was no rain ÷ by the total number of periods when conidia were collected; the false positive proportion (FPP), which was the proportion of periods when no conidia were collected but it rained ÷ by the total number of periods when no conidia were collected; and the true negative proportion (TNP or specificity), which was the proportion of periods when no conidia were collected and there was no rain ÷ the total number of periods when no conidia were collected.

A receiver operating characteristic curve (ROC) analysis was used to evaluate rain as a predictor for collecting *F. erobotryae* conidia. ROC analysis measures the accuracy of different cut-off points (i.e., the different rain cut-offs during the trapping period) as predictors. Sensitivity was plotted against 1-specificity for each of the cut-off points. The closer a ROC curve is to the upper left corner of the plot, the greater the accuracy of the test (Zweig and Campbell, 1993; Hanley, 2005). The area under the ROC curve (AUROC) and its standard error were used to evaluate the analysis; AUROC values between 0.5 and 1 indicate that the variable (a rain event in this case) is a good predictor of the response variable (collection of conidia in this case). The *P* value was calculated as the probability that the AUROC is significantly different from 0.5 (i.e., the ROC curve coincides with the line of no discrimination, 0,0 and 1,1).

Bayesian statistics were applied to evaluate the posterior probability of a capture event being predicted for each of the rainfall cut-off points, as described by Madden (2006). Bayesian analysis enables one to calculate conditional probabilities. In this case, the conditional probabilities were: the probability of collecting *F. erobotryae* conidia when it was predicted $P(P+|O+)$ based on rainfall; the probability of not collecting conidia when it was not predicted $P(P-|O-)$; the probability of not collecting conidia when it was predicted $P(P+|O-)$, and the probability of collecting conidia when it was not predicted $P(P-|O+)$. These probabilities were compared to the prior probabilities of collecting conidia occurring, calculated for each rainfall cut-off point as the proportion of periods with $P(O+)$ or without $P(O-)$ conidia. The overall accuracy of the predictor was calculated as the ratio between correct and total predictions.

To assess the spatial pattern of the disease, the area under the disease progress curve (AUDPC) (Campbell and Madden, 1990) was calculated for each tree in orchard A in each year. Incidence data were used to calculate the index of dispersion, *D*, as a measure of the degree of aggregation of the disease. *D* is the ratio of two variances: the observed variance and the estimated one under the assumption that the data have a binomial distribution. A value of $D > 1$ indicates

departure from a completely random pattern; such a departure would indicate heterogeneity at the scale of the sampling unit (Madden *et al.*, 2007). D was calculated as: $D = s_y^2 / (\bar{y} \times (1 - \bar{y}) / n)$, where s_y^2 is the observed variance and $\bar{y} \times (1 - \bar{y}) / n$ is the binomial variance for number of individual elements (fruit) n in each sampling unit (tree), N . The dispersion index for each tree (D_{tree}) and for the orchard (D_{orchard}) was calculated for each year. Significance was calculated for D_{tree} , under the null hypothesis of a random distribution, $(N-1) \times D$ that follows a χ^2 distribution with $(N-1)$ degrees of freedom, N being the number of sampling units (trees) (Madden *et al.*, 2007).

For each year, aggregation through time was evaluated by the binary power law, which describes the relationship between the observed variance and the binomial variance, under the form: $\ln(s_y^2) = \ln(a) + b \times \ln(\bar{y} \times (1 - \bar{y}) / n)$; where s_y^2 is the observed variance and $\bar{y} \times (1 - \bar{y}) / n$ is the binomial variance for the number of individual elements (fruit) n in each sampling unit (tree). When a and b both =1, the pattern is random; when a is >1 and b is =1, the spatial pattern is aggregated, but the level of aggregation is not directly influenced by the mean; when a and b are both >1, the spatial pattern is considered to be aggregated, and the aggregation is directly related to the mean (Madden *et al.*, 2007). The significance of the estimated parameters was determined with a t -test, and goodness of fit was evaluated using the adjusted coefficient of determination (R^2). A covariance analysis measured the effect of sample year on the intercept and on the slope parameters.

The statistical software SPSS (V19.0; SPSS Inc.) was used for all analyses.

Results

Spore dispersal monitoring. No conidia of *F. erobotryae* were collected by the Burkard spore sampler. Conidia were observed in the rain collectors from March to May in 2011, and from January to April in 2012. However, conidial concentrations were highly variable in both orchard A (average of 541 conidia/mm of rain; SE=372; with upper 95% confidence interval of 1269 conidia/mm of rain) and orchard B (average of 141 conidia/mm of rain; SE=68; 95% confidence interval between 8 and 274). Moreover, no relationship between the number of conidia collected in each week and the amount of rain, the number of rain events or the duration of the rain periods in the week, was observed. The most consistent data regarding conidia dispersal were obtained with microscope slides coated with silicone. Total conidia collected over two seasons were much lower on the vertical compared with the horizontal slides. In total, in orchard A,

332 conidia/cm²±28.7 (SE from the 3 replicates) were collected by the vertical slides and 37960 conidia/cm²±10403 by the horizontal slides. In orchard B, 314 conidia/cm²±41.44 were collected by the vertical slides and 20790 conidia/cm²±6520.57 by the horizontal slides (Table 4.1).

Table 4.1. Collection of conidia of *Fusicladium eribotryae* on vertical and horizontal microscope slides in relation to rainfall events during the sampling periods in two loquat orchards (A and B) in Alicante, Spain, in 2011 and 2012.

Rain ^a	Positive collection ^a				N. of conidia/cm ² collected			
	Vertical slides ^b		Horizontal slides ^c		Vertical slides		Horizontal slides	
	A	B	A	B	A	B	A	B
No	6 ^d (21.4)	6 (21.4)	6 (18.8)	3 (10.7)	21 ^e (6.4)	4 (1.3)	155 (0.4)	300 (1.4)
Yes	22 ^d (78.6)	22 (78.6)	26 (81.3)	25 (89.3)	311 ^e (93.6)	310 (98.7)	37805 (99.6)	20490 (98.6)

^a At least one rain event (i.e. >0.2mm) during each sampling period (one week).

^b Number of sampling periods with at least one conidium of *F. eribotryae* collected.

^c The vertical slide sample consisted of four microscope slides placed 1.60 m above the ground and between the tree canopies.

^d The horizontal slide sample consisted of two microscope slides placed 1.30 m above the ground and under the tree canopy.

^e Values in parentheses are the percentages with respect to the total sampling periods with positive samples for the indicated orchard and slide orientation; aggregate data for 2011 and 2012.

^f Total number of *F. eribotryae* conidia/cm² collected in sampling periods with positive samples; values in parentheses are the percentages with respect to the total number of conidia collected for the indicated orchard and slide orientation.

In 2011, the first *F. eribotryae* conidia were collected in the second week of March by horizontal slides in orchard A and B, and by rain collectors only in orchard A (Fig. 4.1 A and 4.1 B); in that period, there were 5 rain events, with a total of 46.4 mm of rain (Fig. 4.1 B). No, or very few conidia were collected between first and mid-April of 2011, a period of little rain and increasing temperature. The peak in dispersal of conidia in 2011 occurred during the last 2 weeks of April, when almost 18,000 and 12,000 conidia/cm² were collected on the horizontal slides in orchard A and B, respectively; 51.4 mm of rain fell during that period (Fig. 4.1). In orchard A, decreasing numbers of conidia were collected until the end of May (Fig. 4.1 A). However, in orchard B substantial numbers of conidia were collected from the second week of May to the end of the experiment (Fig. 4.1 B). Conidia of *F. eribotryae* were found in the rain collectors placed

under the tree canopy during 6 sampling periods in orchard A and at 7 sampling periods in orchard B, when substantial amounts of rain were recovered. The incidence of scab on fruit increased progressively from mid-March to the end of the season when 27% of fruit were diseased (Fig. 4.1 A).

In 2012, the first conidia collected in orchard A were in the second week of January, when >100 mm of rain fell (Fig. 4.2 A and 4.2 B). Between the second week of January and the third week of March in 2012, there was little rain, and few conidia were collected on the horizontal slides. The peak in conidia dispersal in 2012 was at the end of April, when almost 8,000 and 2,000 conidia/cm² of slide surface were collected in orchard A and B, respectively (Fig. 4.2 A and 4.2 B). Few conidia were collected in orchard B in 2012, probably due to reduced vegetation and fruit after 6 years of orchard neglect. Conidia were found in the rain collector samples in 7 and 8 periods in orchard A and B, respectively. Disease incidence was higher in 2012 (Fig. 4.2 A) compared with 2011 (Fig. 4.1 A), with 96.7% of fruit showing symptoms of loquat scab at harvest. In 2011, the greatest increase in disease incidence occurred after the 1st of April, 3 weeks after the first appreciable numbers of conidia were collected on the glass slides (Fig. 4.1 A); in 2012 the greatest increase in disease incidence occurred in the second half of February, about 4 weeks after the first appreciable numbers of conidia were collected on the glass slides (Fig. 4.2 A).

Effect of rain on spore collection. Rain coincided with 78.6% to 89.3% of the sampling periods in which conidia of *F. eriobotryae* were collected, depending on the spore collecting device and the orchard (Table 4.1); of the total conidia collected, 93.6 to 99.6% were collected when sampling periods coincided with rain (Table 4.1). Due to the similarities in the numbers of conidia collected by both the horizontal and vertical slides, the analyses used only the data from the horizontal slides (orchard A and B).

The close association between rain and collection of conidia by the horizontal slides was confirmed by the ROC analysis (Fig. 4.3). The AUROC value was 0.795, which was significantly greater than 0.5 ($P < 0.001$). For prediction purposes, the optimal combination of sensitivity/specificity values and the highest accuracy were obtained with a rainfall cut-off of ≥ 0.2 mm (Table 4.2). Bayesian analysis indicated that the ≥ 0.2 mm cut-off point had a high probability to correctly predict a positive conidia collection event ($P+|O+$) (0.797), and the lowest probability of failing to predict a positive trapping ($P-|O+$) (0.243).

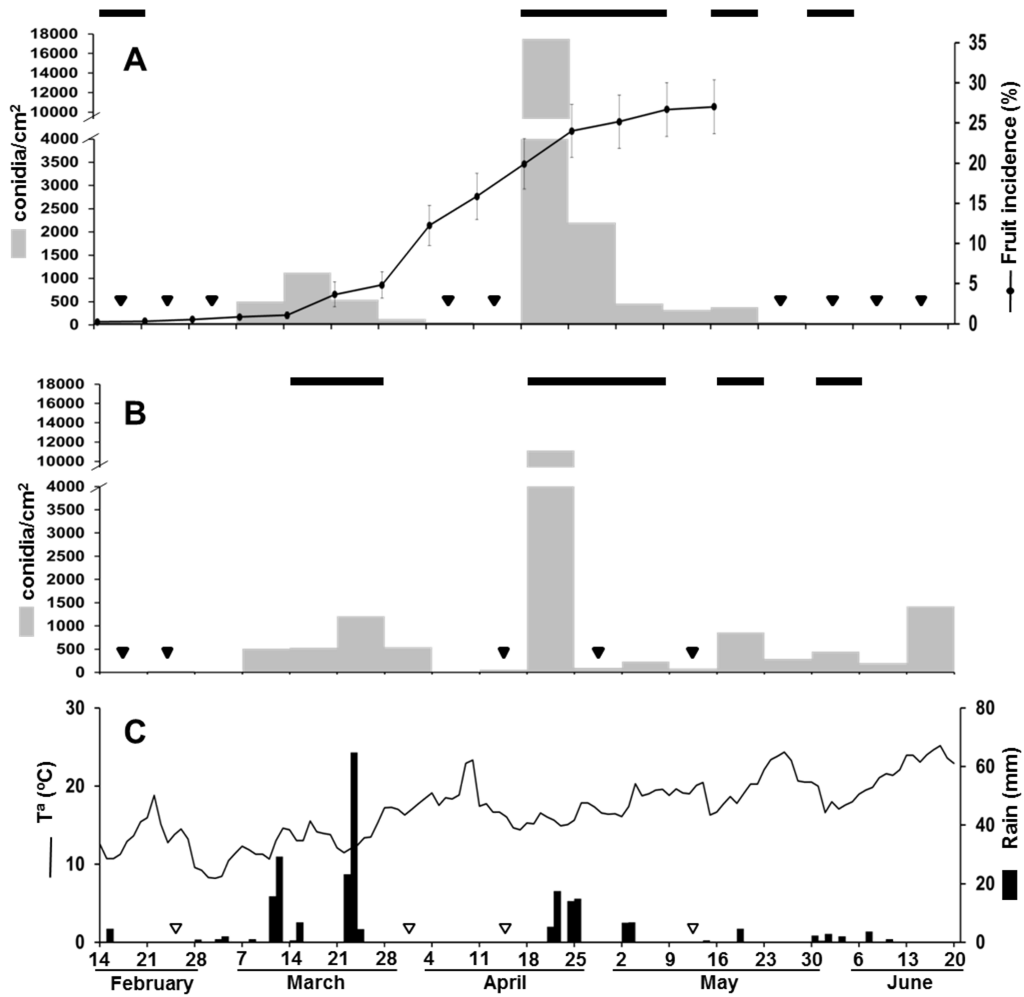

Figure 4.1. Weekly number of conidia of *Fusicladium eriobotryae* collected on horizontal slides, and scab incidence in 2011 in loquat orchard A (A) and loquat orchard B (B) relative to daily temperature and rainfall (C). In A and B, horizontal black lines (■) indicate weeks in which at least one *F. eriobotryae* conidium was detected in the rain collectors. Full triangles (▼) indicate weeks in which 100 conidia were captured on horizontal slides; empty triangles (▽) indicate weeks in which <1 mm of rain was recovered. Whiskers in A indicate standard errors for percentage of fruits with disease.

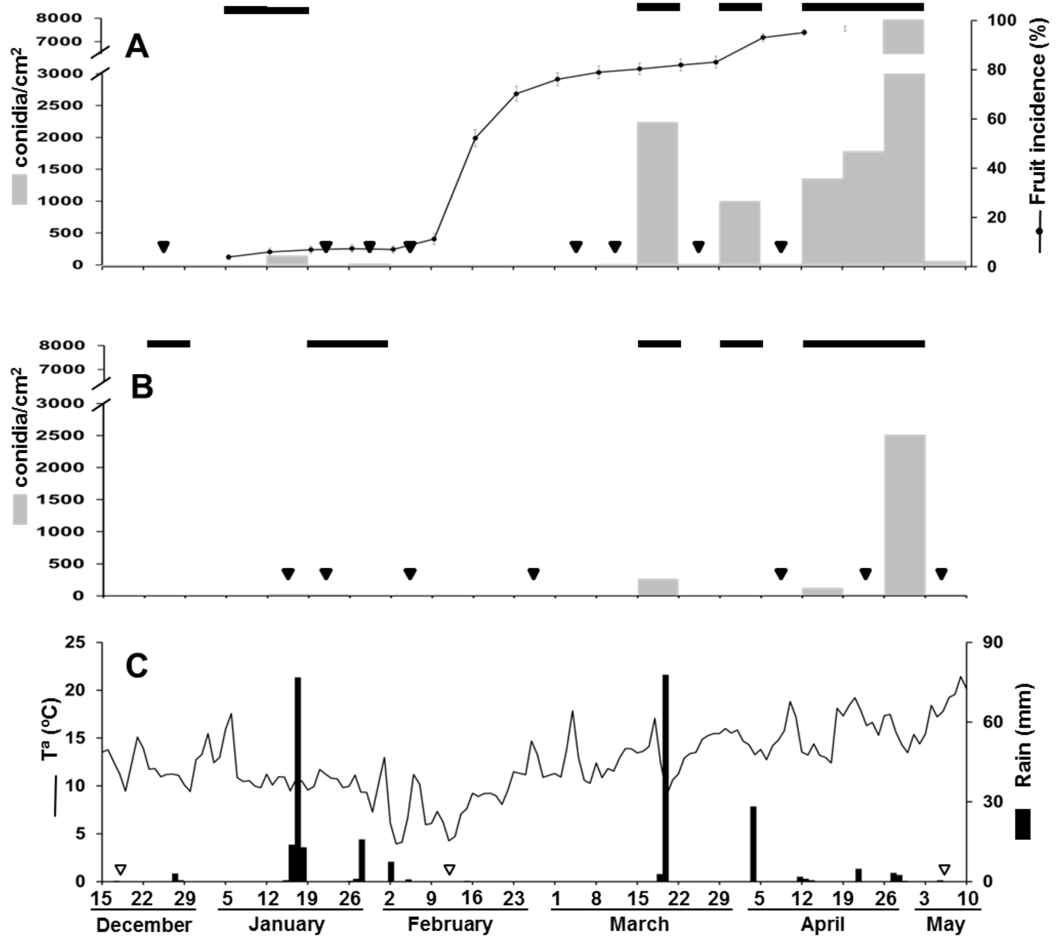

Figure 4.2. Weekly number of conidia of *Fusicladium eriobotryae* collected on horizontal slides, and scab incidence in 2012 in loquat orchard A (A) and loquat orchard B (B) relative to daily temperature and rainfall (C). In A and B, horizontal black lines (■) indicate weeks in which at least one *F. eriobotryae* conidium was detected in the rain collectors. Full triangles (▼) indicate weeks in which <100 conidia were captured on horizontal slides; empty triangles (▽) indicate weeks in which <1 mm of rain was recovered. Whiskers in A indicate standard errors for percentage of fruits with disease.

Table 4.2. Evaluation of rainfall to predict collection of *Fusicladium eriobotryae* on slides^a placed under loquat trees in orchards A and B in Alicante, Spain, in 2011 and 2012.

Rain ^b	TPP ^c	TNP	FPP	FNP	Overall accuracy ^d	Prob(O+) ^e	Prob(O-)	(P+ O+) ^f	(P- O-)	(P+ O-)	(P- O+)
≥ 0.2	0.850	0.536	0.464	0.150	0.750	0.682	0.318	0.797	0.757	0.203	0.243
≥ 0.5	0.683	0.893	0.107	0.317	0.750	0.682	0.318	0.932	0.596	0.068	0.404
≥ 1	0.603	0.833	0.167	0.397	0.682	0.659	0.341	0.875	0.566	0.125	0.434
≥ 3	0.583	0.893	0.107	0.417	0.682	0.682	0.318	0.921	0.528	0.079	0.472
≥ 5	0.400	0.929	0.071	0.600	0.568	0.682	0.318	0.923	0.438	0.077	0.563

^a Slides were placed horizontally as referred to in Table 4.1.

^b Total rainfall (mm) that were used to define a rain event.

^c TPP (true positive proportion, or sensitivity), which was the number of periods when conidia were collected and it rained ÷ the total number of periods when conidia were collected; FNP (false negative proportion), which was the proportion of periods when conidia were collected but there was no rain ÷ by the total number of periods when conidia were collected; FPP (false positive proportion), which was the proportion of periods when no conidia were collected but it rained ÷ by the total number of periods when no conidia were collected; and TNP (true negative proportion, or specificity), which was the proportion of periods when no conidia were collected and there was no rain ÷ the total number of periods when no conidia were collected.

^d Overall accuracy calculated as the proportion of correct predictions.

^e Prior probability of occurrence (O+) and no occurrence (O-) of periods when conidia were collected during a period with the indicated amount of rain.

^f Posterior probability of collecting conidia when it was predicted based on rain (P+|O+); posterior probability of not collecting conidia when it was not predicted (P-|O-); posterior probability of not collecting conidia when it was predicted (P+|O-); and posterior probability of collecting conidia when it was not predicted (P-|O+)

Rainfall cut-offs >0.2 mm provided lower probability values for the TPP and higher probability values for the TNP, despite similar accuracy; the probability of correctly predicting a conidia collection event ($P+|O+$) increased, but the probability of not predicting a positive conidia collection event when it actually occurs ($P-|O+$) also increased at the higher rainfall cut-off points (Table 4.2). The cut-off value ≥ 5 mm greatly increased the TNP (0.929) and the probability of correctly predicting a conidia collection event (0.923), but also greatly increased the probability of failing to predict a conidia collection event (0.563).

Spatial pattern of loquat scab. The AUDPC was greater in 2012 compared with 2011, but there was variability among the 46 trees evaluated (Fig. 4.4). In 2011, the AUDPC values ranged from 0 (for some trees in rows 1 to 3) to >30 (for some tree in rows 4 and 5). Variability was also high between adjacent trees; for instance, the AUDPC was 35.7 for the tree in row 4 and stand 8 while the AUDPC was <10 for contiguous trees in the same row (Fig. 4.4 A). In 2012, AUDPC values ranged from 28.1 to 86.4, and differences between adjacent trees were again substantial (Fig. 4.4 B).

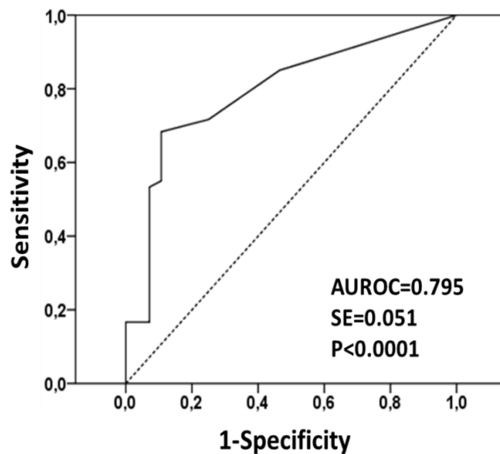

Figure 4.3. Receiver operating characteristic (ROC) curve for the weekly accumulated rainfall (mm) in relation to the probability of collecting conidia of *Fusicladium eriobotryae* (in orchard A and B during 2011 and 2012). The dotted line represents no discrimination. Also indicated are values for area under the receiver operating characteristic curve (AUROC), AUROC standard error (SE), and the probability the AUROC is different to 0.5 (P).

At the tree scale, the index of dispersion (D_{tree}) varied through the season in both 2011 and 2012 (Fig. 4.5). In 2011, the number of trees showing an aggregated pattern of diseased fruit (i.e., $D_{tree}>1$) increased progressively during the season (Fig. 4.5 A to 4.5 G); at the time of the last assessment, the pattern of disease was aggregated for 56.5% of the trees (Fig. 4.5 G). In 2012, most trees showed an aggregated pattern of disease from 16 February, when 52.1% of fruit were diseased, until 28 March, when 83.1% of the fruit were scabbed (Fig. 4.5 H to 4.5 M).

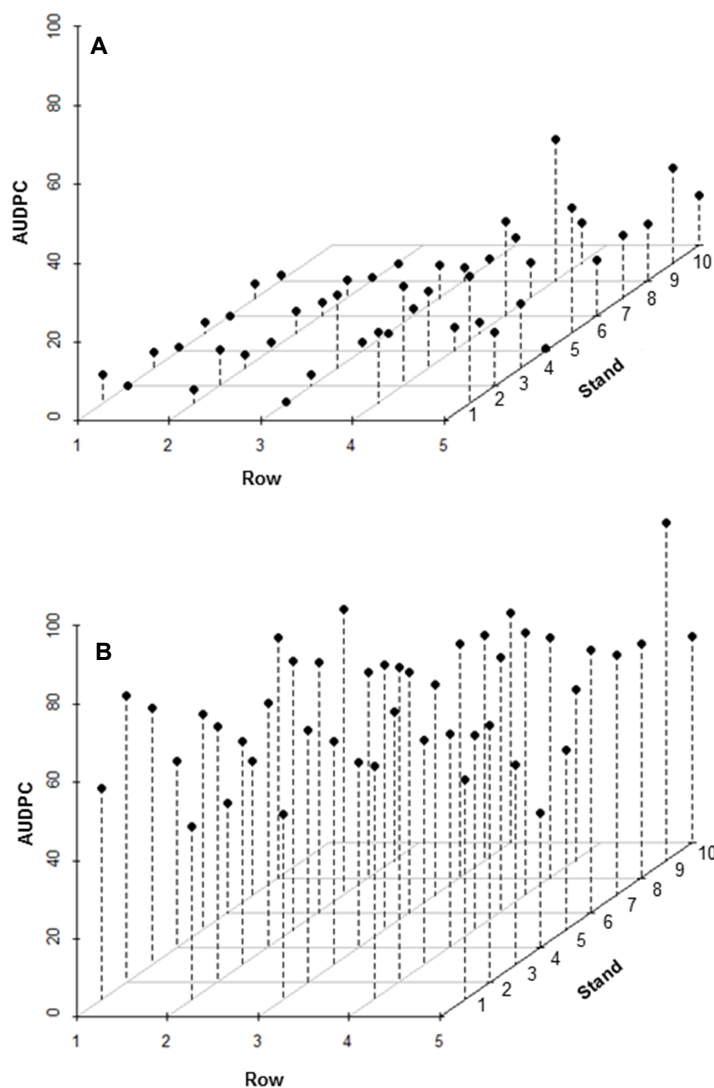

Figure 4.4. Values of the area under the disease progress curve (AUDPC) for incidence of loquat scab in orchard A in southeastern Spain in 2011 (A) and 2012 (B). Each point corresponds to the AUDPC value of one of the 46 trees in the orchard (the orchard was surveyed 14 times in 2011 and 16 times in 2012).

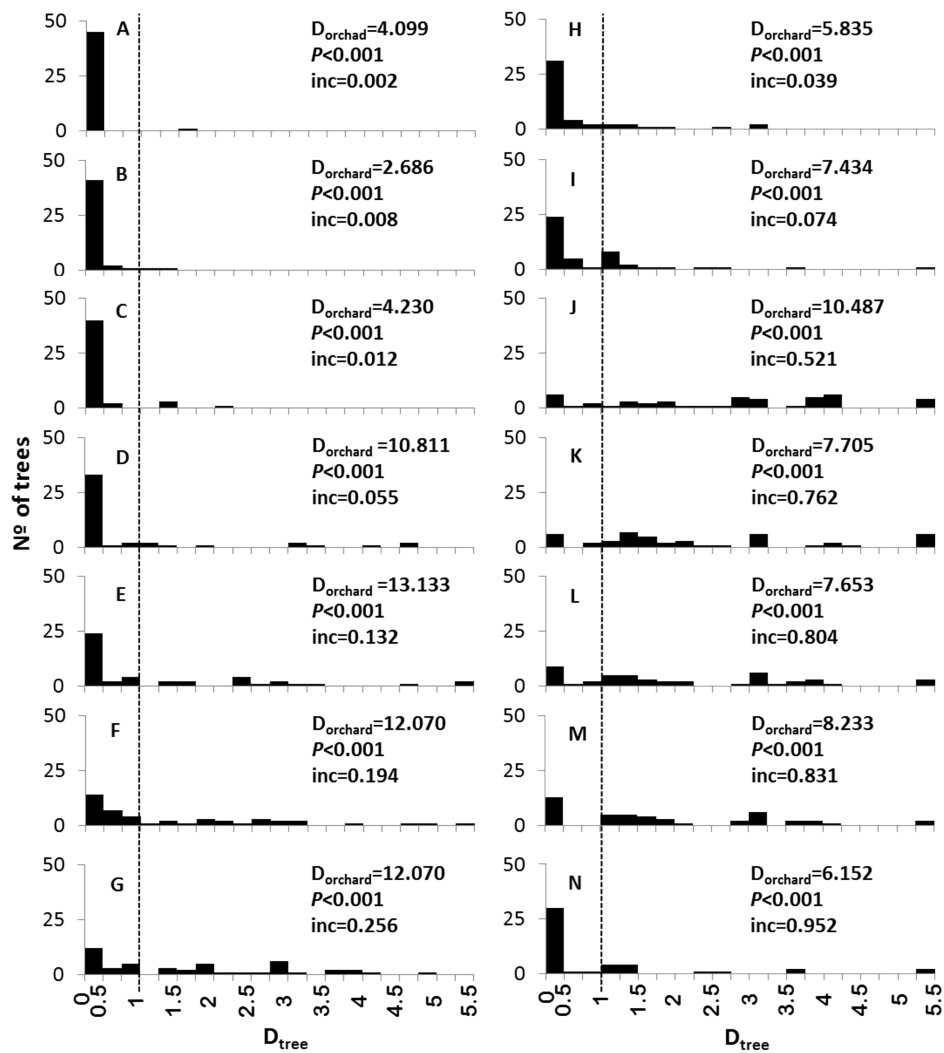

Figure 4.5. Frequency distribution of the dispersion index (D_{tree}) of fruit with symptoms of loquat scab (caused by *Fusicladium eriobotryae*) in 46 trees of loquat in orchard A in southeastern Spain during seven sampling periods in 2011 (A: 17 January, B: 28 February, C: 14 March, D: 28 March, E: 04 April, F: 18 April and G: 02 May) and in 2012 (H: 05 January, I: 26 January, J: 16 February, K: 01 March, L: 15 March, M: 28 March and N: 12 April). The following are indicated for each sampling period: the dispersion index for the orchard ($D_{orchard}$), the probability (P) that $D_{orchard}$ is significantly >1 , and the average disease incidence (inc). Values of $D_{tree}>1$ (dotted line) indicate aggregation in the spatial pattern of disease.

At the orchard scale, the index of dispersion (D_{orchard}) ranged from 0.95 to 4.66 in 2011 and from 2.07 to 3.73 in 2012; all D_{orchard} values were significantly greater than 1 ($P < 0.05$) according to the χ^2 test, except the D_{orchard} value from 11 February 2011 (Fig. 4.5). The binary power law provided a good fit ($R^2 = 0.951$), and the estimated slope and intercept of the linear regression were both significantly > 1 ($P < 0.001$ in both cases) (Fig. 4.6), indicating that between-tree heterogeneity changed systematically with disease incidence. Based on covariance analysis, the year of sampling had a significant effect on the intercept ($P < 0.001$) although the interaction between the year of sampling and the slope parameter was not significant ($P = 0.074$).

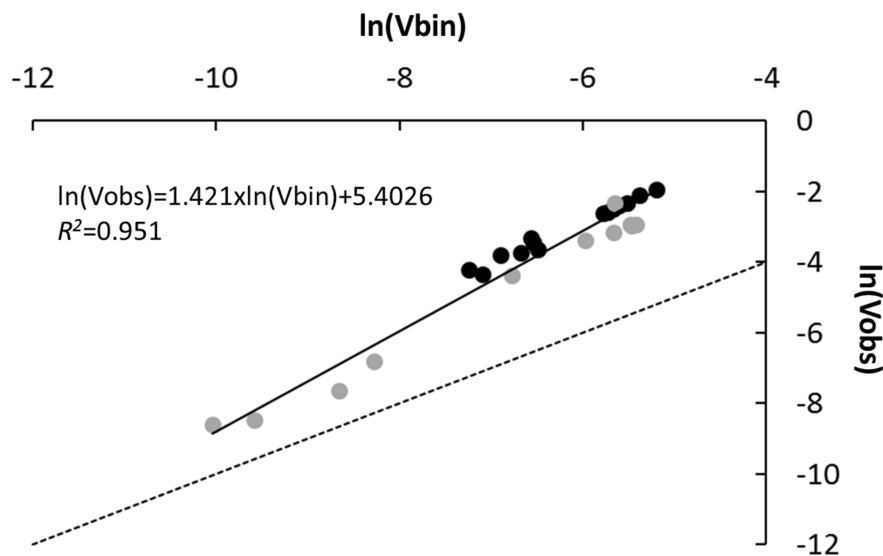

Figure 4.6. Relationship between the logarithm of the binomial variance and the logarithm of the variance of the incidence of loquat scab in orchard A in Alicante, Spain. The grey circles and black circles represent the observations from 2011 and 2012, respectively. The solid line represents the linear regression, and the dotted line represents the binomial line (i.e., when the observed variance equals the binomial variance). The regression equation between $\ln(V_{bin})$ and $\ln(V_{obs})$ and the adjusted R^2 are indicated; the probability that the intercept and slope of the regression line are > 1 is < 0.001 in both cases.

Discussion

Dispersal of *F. eriobotryae* in loquat orchards was investigated by using spore samplers and studying the spatial pattern of loquat scab on fruit. The studies collectively demonstrated that conidia of *F. eriobotryae* are dispersed primarily through rain splash. Although this assumption was suggested by Salerno *et al.* (1971a), no previous data for dispersal of conidia of *F. eriobotryae* in rain splash had been obtained.

Conidia were collected on microscope slides during the period of fruit development (March to May in 2011 and January to May in 2012). In both years, the majority of conidia were collected between March and May. Most of the conidia were collected during periods with rain, and about 90% of the *F. eriobotryae* conidia collected were during rainy periods. The only difference between horizontal and vertical slides was in the total number of conidia captured, which was almost 100 times greater on the horizontal slides compared with the vertical slides. Horizontal microscope slides are suitable for trapping rain-splashed spores, because most of these spores are carried in large (>200 μm in diameter) ballistic splash droplets, which are efficiently intercepted by these samplers (Fitt *et al.*, 1989; Campbell and Madden, 1990). No conidia were collected by the volumetric spore trap, and it is not suitable for trapping rain-splashed spores (Jackson and Bayliss, 2011). Rain collectors have been used frequently for spore dispersal studies (Ooka and Kommendahl, 1977; Carisse *et al.*, 2006; Amponsah *et al.*, 2009) including for the related *F. oleagineum* (Lops *et al.*, 1993). Conidia of *F. eriobotryae* were found in most of the rain samples, but with high variability in conidia counts. No relationships were found between the numbers of conidia collected and the quantity of rain; during sampling periods with high rainfall, overflowing of gatherers and/or dilution of conidia might have biased the conidial counts.

ROC analysis showed that rainfall is a good predictor of dispersal of *F. eriobotryae* conidia. The use of ≥ 0.2 mm of rain as the cut-off for defining a rain event combined a high probability of predicting conidial dispersal when dispersal actually occurred and a low probability of failing to predict dispersal when dispersal actually occurred. ROC analysis has been used previously to evaluate rain as a predictor of spore dispersal for other fungal pathogens (Yuen and Hughes, 2002; Turechek and Wilcox, 2005; Madden, 2006; Caffi *et al.*, 2013).

Studies of spore dispersal with other species of the Venturiaceae including *F. oleagineum*, *F. effusum*, and *F. carpophilum* indicated that conidia were trapped mainly during or soon after rain events (Gottwald and Bertrand, 1982; Latham, 1982; Gottwald, 1983; Scherm and Lan, 2003; Scherm *et al.*,

2008). However, in the case of *F. pomi*, conidia were consistently trapped during periods without rain (Hirst and Stedman, 1961; Sutton *et al.*, 1976). Strong aggregation of loquat scab was observed between loquat trees, i.e., the dispersion index was significantly >1 for most of the assessments performed in both years of the study. In addition, an aggregated disease pattern was observed within each tree when the percentage of affected fruit in the orchard was $>10\%$. The binary power law and the covariance analysis indicated high aggregation of the disease, which was influenced by disease incidence and year of assessment. The analysis of the spatial pattern of plant diseases has been used to evaluate the degree of association among sampling units and to develop biological and environmental hypotheses about the dispersal of the pathogen propagules (Campbell and Madden, 1990; Madden *et al.*, 2007); an aggregated pattern has been related to splash dispersal, in which droplets originating from raindrops falling on sporulating lesions may disperse spores (Waggoner and Rich, 1981; Madden, 1992).

The results obtained in this work are in general agreement with studies of related species. Carisse *et al.* (2009) found with apple scab that the number of scabbed leaves per shoot was slightly aggregated, but the spatial pattern of lesions on leaves was highly aggregated (Carisse *et al.*, 2011). Although the spatial pattern of olive scab (caused by *F. oleagineum*) has not been determined, studies on spore dispersal gradients showed that the numbers of conidia trapped near the inoculum source (<10 m) were linearly and positively related with cumulative rainfall (Viruega *et al.*, 2013), and the number of dispersed conidia decreased exponentially with increasing distance from the inoculum source. Similar results were obtained for *V. nashicola* (Umemoto, 1990). Gradients in disease were reported for pecan scab in pecan tree canopies, indicating splash dispersal (Bock *et al.*, 2013b), and the distribution of lesions of peach scab (caused by *F. carpophilum*) on peach fruit was also indicative of a splash dispersed pathogen (Bock *et al.*, 2011b).

It is established that rain splash plays a key role in spore dispersal of many plant pathogens, especially for those fungi that produce spores in asexual fruiting structures such as sporodochia, pycnidia, or acervuli (Fitt *et al.*, 1989; Madden, 1992). Conidia of *Fusicladium* spp., however, are not formed in specialized fruiting structures; rather, *Fusicladium* spp. conidia are produced on and are firmly attached to short, stout, free conidiophores (Schubert *et al.*, 2003). Both the short length of the conidiophores and the firmness of conidia attachment to the conidiophore may explain why *Fusicladium* conidia are not easily liberated by wind (McHardy, 1996; Lan and Scherm, 2003).

Conidia of *F. oleagineum* and *F. eriobotryae* require longer periods for germination and infection than those of *V. inaequalis* (Gottwald, 1985; Hartman *et al.*, 1999; Obanor *et al.*, 2008b, 2010; Viruega *et al.*, 2011; González-Domínguez *et al.*, 2013b). Therefore, rain-dependent dispersal of scab diseases of Mediterranean plants, such as loquat and olive, can be considered an adaptation to a dry climate: relative to wind-dispersed conidia, rain-dispersed conidia will have a greater probability of experiencing a long wetness periods required for germination and infection.

Mycelial growth, conidial germination, and infection of loquat leaves by *F. eriobotryae* have been modelled based on environmental factors (González-Domínguez *et al.*, 2013b). The results from that study can be combined with those from the present work in a mechanistic, weather-driven, disease prediction model. The disease prediction model should consider that in the presence of sporulating scab lesions in a loquat orchard, any rainfall ≥ 0.2 mm can splash droplets carrying conidia that will subsequently trigger infection if temperature and surface wetness conditions are favorable. Information on available inoculum in an orchard should be considered in predicting the risk of infection. Currently, there is no available information on the effect of weather on sporulation of *F. eriobotryae*, and so further studies are warranted.

Because the conditions for *F. eriobotryae* conidia dispersal and infection are more stringent than those for *V. inaequalis*, the Mill's tables, which are based on the biology and epidemiology of *V. inaequalis*, and which are currently used to schedule fungicide applications for control of loquat scab in Spain, may over-predict the occurrence of *F. eriobotryae* infection. It follows that a predictive model based on the biology and epidemiology of *F. eriobotryae* should help growers in Mediterranean areas reduce fungicide usage in loquat scab management.

Acknowledgements

This work was funded by the Cooperativa Agrícola de Callosa d'En Sarrià (Alicante, Spain). Financial support by the Programa de Apoyo a la Investigación y Desarrollo (PAID-00-12) de la Universidad Politécnica de Valencia for E. González-Domínguez during her 3-month stay at the Università Cattolica del Sacro Cuore (Piacenza, Italy) is gratefully acknowledged. We would like to thank E. Soler, A. Perez and J.J. Giner for their technical assistance.

Chapter 5

Chapter 5

Development and validation of a standard area diagram set to aid assessment of severity of loquat scab on fruit

Elisa González-Domínguez¹, Ricardo Brainer Martins², Emerson Medeiros Del Ponte³, Sami Jorge Michereff⁴, José García-Jiménez¹, Josep Armengol¹ (2014). *European Journal of Plant Pathology* 139:413–422.

¹Instituto Agroforestal Mediterráneo, Universidad Politécnica de Valencia, Camino de Vera s/n, 46022 Valencia, Spain.

²Campus Arapiraca, Universidade Federal de Alagoas, 57309-005 Arapiraca, AL, Brazil.

³Departamento de Fitossanidade, Faculdade de Agronomia, Universidade Federal do Rio Grande do Sul, 91540-000 Porto Alegre, RS, Brazil.

⁴Departamento de Agronomia, Universidade Federal Rural de Pernambuco, 52171-900 Recife, PE, Brazil.

Abstract

A standard area diagram set (SAD) to aid visual assessment of loquat scab (caused by *Fusicladium eriobotryae*) severity on fruit was developed and evaluated for improving accuracy, precision and reliability of visual estimates. The SAD set contains eight black and white diagrams of diseased fruit with severity values from 2% to 98%. To evaluate the SADs, a group of 20 raters (comprising 10 'experienced' and 10 'inexperienced' raters) assessed the same set of 50 images three times, the first without SADs and the second and third using the SADs as an aid. Only for the group of inexperienced raters did SADs significantly improve accuracy (bias correction factor, $C_b=0.93$ without SADs and 0.98 with SADs), precision (correlation coefficient, $r=0.88$ without SADs and $r=0.96$ with SADs) and overall agreement (Lin's concordance correlation coefficient, $\rho_c=0.82$ without SADs and ρ_c with SADs=0.95) of the estimates. Accuracy and precision of the estimates by inexperienced raters were significantly higher than those obtained by the experienced raters, especially for the second assessment with SADs. Inter-rater reliability was improved when SADs were used by inexperienced raters, whereas a high degree of intra-rater reliability was obtained by both, experienced and inexperienced raters when using SADs. The SADs developed in this study were useful for obtaining more accurate, precise and reliable assessments of loquat scab for inexperienced raters, and should be used as an aid for assessing scab in epidemiological studies or monitoring for decision-making purposes.

Introduction

Loquat (*Eriobotrya japonica* (Thunb) Lindl.) is a fruit tree grown in regions with a subtropical climate (Calabrese, 2006) including China, Japan and the Mediterranean basin (Caballero and Fernández, 2002; Lin, 2007; MAGRAMA, 2013). In 2006, global production of loquat fruit was estimated to be 550,000 tons with a crop area >130,000 ha (Lin, 2007). China is the leading producer followed by Spain. Spain is the major exporter, and >50% of loquat production (28,812 t) is cultivated in the southeastern region of the country (Caballero and Fernández, 2002; Soler, 2007; MAGRAMA, 2013).

Loquat scab, caused by *Fusicladium eriobotryae* (Cavara) Sacc., is the major fungal disease affecting loquat in Spain (Soler, 2007; Sánchez-Torres *et al.*, 2009) and other regions of the Mediterranean basin (Caballero and Fernández, 2002; Sánchez-Torres *et al.*, 2009; Gladiux *et al.*, 2010). The fungus infects the leaves, fruits and young branches, particularly in their early stages of development. The symptoms are generally most noticeable and serious on fruit, and are first visible as circular, chlorotic spots which increase in size and become brown to olive and velvety in appearance due to production of asexual spores. Eventually, the spots become dark brown, coalesce and can cover almost the entire surface of the fruit (Rodríguez, 1983; Sánchez-Torres *et al.*, 2009) (Fig. 5.1). The symptoms may appear throughout the flowering and fruit developmental stages from February to June in the northern hemisphere (Sánchez-Torres *et al.*, 2009). In years with a warm winter and a rainy spring, the incidence of the disease on fruit can be as high as 50% (Rodríguez, 1983). Scabby fruit are unacceptable for sale, resulting in significant economic losses (Sánchez-Torres *et al.*, 2009). The etiology and pathogen biology of loquat scab in Spain have been studied recently (Sánchez-Torres *et al.*, 2009; González-Domínguez *et al.*, 2013b), but the epidemiology of the disease remains poorly understood and no standardized disease assessment method is available.



Figure 5.1. Fruit of loquat with typical symptoms of scab.

While estimates of incidence can be accurate and easy to obtain, estimates of severity may be affected by the inherent ability of the rater (Campbell and Madden, 1990). However it has been shown that training, experience and use of aids during assessments, such as standard area disease diagrams (SADs), lead to improved accuracy (closeness of the estimate to the true value) and reliability (the extent to which the same measurements of individuals obtained under different conditions yield similar results) of the estimates (Kranz, 1988; Madden *et al.*, 2007).

Ideally, disease assessment methods should be evaluated to ensure accuracy and reliability. Intra-rater reliability (repeatability) is the consistency of estimates by the same rater evaluated at different times, and inter-rater reliability (reproducibility) is the consistency of estimates by different raters. The percentage of leaf or fruit area affected by disease as determined by image analysis is usually considered a “true” severity (Madden *et al.*, 2007; Bock *et al.*, 2010). Severity can be estimated directly with or without assessment aids or using disease scales such as the one proposed by Horsfall and Barratt (Kranz, 1988; Campbell and Madden, 1990; Madden *et al.*, 2007).

SADs, also known as diagrammatic scales (Godoy *et al.*, 1997) or disease diagrams (Madden *et al.*, 2007), are pictorial diagrams that depict the true proportion of damage (usually disease severity) on individual sampling units (quadrants, whole plants, leaves, fruit, tubers, etc.). Although it has long been stated that the use of SADs led to improved accuracy and precision of visual estimates (James, 1971; Horsfall and Cowling, 1978; Kranz, 1988), only recently have studies provided evidence (some with statistical support) that estimates by individual raters are usually more accurate and precise when made with the aid of SADs compared to unaided estimates (Corrêa *et al.*, 2009; Michereff *et al.*, 2009; Lima *et al.*, 2011; Spolti *et al.*, 2011; Capucho *et al.*, 2011; Bardsley and Ngugi, 2013). Additionally, some studies have investigated the effect of experience of the rater on both accuracy and precision, and inexperienced raters tended to respond more to the use of SADs compared to experienced raters (Michereff *et al.*, 2000; Nita *et al.*, 2003; Godoy *et al.*, 2006; Bock *et al.*, 2009, 2013a; Pedroso *et al.*, 2011; Sachs *et al.*, 2011; Klosowski *et al.*, 2013; Yadav *et al.*, 2013).

The objectives of this study were to 1) develop a SAD set as an assessment aid for estimating loquat severity based on a sampling of diseased fruit from the field and 2) evaluate the effect of the SAD set and rater experience on the accuracy, precision and reliability of scab severity estimates.

Materials and methods

Loquat fruit and image acquisition. Two hundred diseased loquat fruit (cv. *Algerie*) were collected in May 2011 from an unsprayed loquat orchard in Callosa d'En Sarrià (Alicante province, Southeastern Spain). Cv. *Algerie* has previously been reported as highly susceptible to loquat scab (Sánchez-Torres *et al.*, 2009). Fruit were mature and had a wide range of scab severity (<1 to >90%). An experienced rater selected a subsample of 50 fruit representing the range of severity. This subset was used for all the assessments in this work. Digital images were taken from one lateral view of each fruit using a digital camera (Nikon D-5000, 12.3 megapixels) mounted 30 cm from the fruit.

Image analysis. Each image was analyzed using Assess V2.0 (Image Analysis Software for Plant Disease Quantification, American Phytopathological Society, St Paul, MN, USA (Lamari, 2008)). The true severity was based on the Hue-Saturation-Intensity (HSI) color model, which was used to determine the total area and the diseased area of the fruit in pixels. Threshold levels for healthy fruit and diseased areas were set accordingly and recorded for each fruit image.

Construction and evaluation of the SAD set. The maximum true severity determined by image analysis was 99.7%. Because of the wide range of severity, the SAD set was constructed with eight incremental severity levels (2, 8, 16, 24, 48, 64, 86 and 98%) with the diagrams represented in black and white (Fig. 5.2). Using a standard image of a fruit outline, the lesions were painted manually with shapes and spatial patterns reflecting the actual diseased fruit, which included prominent lesions around the peduncle region of the fruit.

For evaluation purposes, each image of the 50-fruit set was inserted as an individual slide in a Microsoft Powerpoint file. A group of 20 raters (10 'experienced' and 10 'inexperienced') assessed the same set of images. Raters were classified as experienced if they had received previous formal training and practice in disease severity assessment, and were familiar with the symptoms of loquat scab. Inexperienced raters had no formal training or familiarity with plant disease symptoms. For each group, 50 digital images of the diseased fruits, in a random order, were projected one at a time for 15 seconds. The first assessment was done without the SADs. All raters received the same information on how to identify symptoms of loquat scab and visually estimated the percentage of diseased area related to total fruit area for each image.

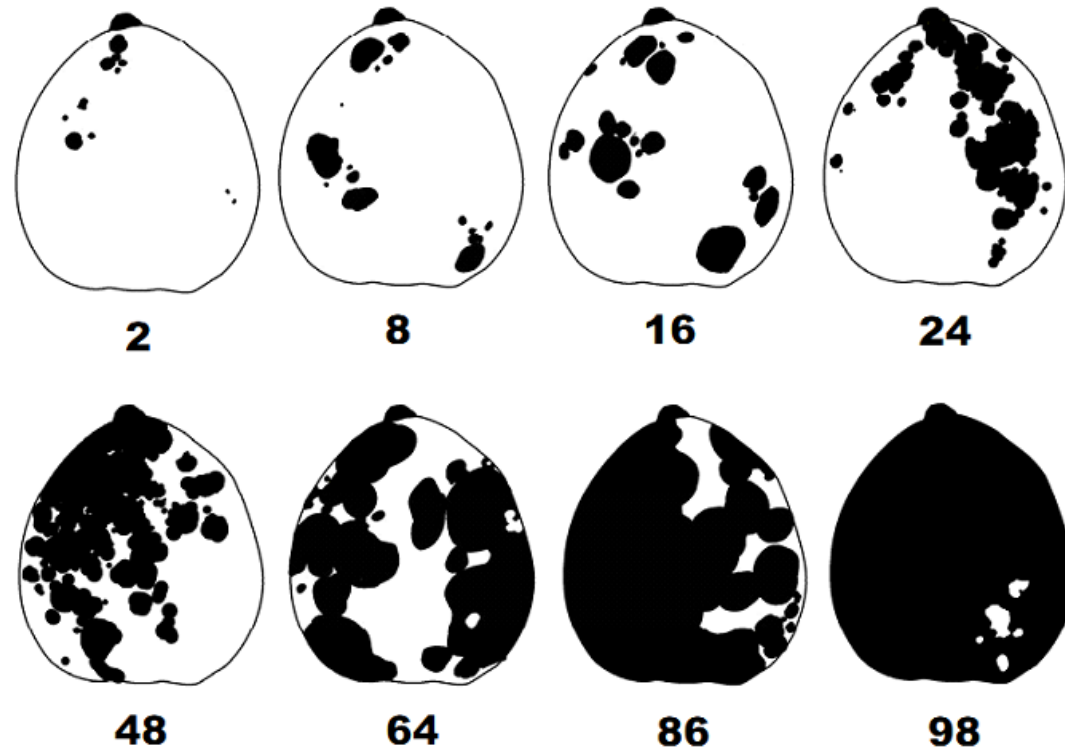

Figure 5.2. The standard area diagram (SAD) set developed as an aid for assessment of scab on fruit of loquat. Each value represents the percentage of loquat scab severity on that image.

Two weeks later, the same 20 raters estimated disease severity, but with the SADs as an aid, receiving instructions on how to use them when estimating severity to the nearest percent (i.e. use those values as reference points to help with their estimation). After a further two-week interval, the raters made a final assessment of the fruit using the SADs (the images were displayed at random for the SADs assessments).

Data analyses. Precision, bias, accuracy, agreement and inter- and intra-rater reliability of estimates were compared without and with the use of the SADs for both inexperienced and experienced raters. Lin's concordance correlation (LCC) analysis (Lin, 1989) was calculated for testing the agreement between estimate and true severity for each rater. The LCC coefficient (ρ_c) combines measures of accuracy and precision to assess the fit of pairs of observations to the line of concordance (45° =perfect concordance). The concordance correlation coefficient is calculated from the Pearson correlation coefficient (r), an indicator of precision, and the bias correction factor (C_b), which measures accuracy and is the distance to the 45° line of concordance. The bias correction factor (C_b) is calculated from μ (location bias, or height shift relative to the perfect relationship where 0=perfect relationship between x and y) and ν (scale bias, or slope shift where 1=perfect relation between x and y), which are derived from the means and standard deviations of x and y , respectively. Thus, the LCC coefficient provides a method to judge agreement with true values and has been previously used to judge agreement in plant disease assessments (Nita *et al.*, 2003; Madden *et al.*, 2007) including estimates with or without SADs (Spolti *et al.*, 2011; Yadav *et al.*, 2013).

Following Yadav *et al.* (2013), the overall effect of the use of SADs and of the experience of the rater, with or without SADs, were statistically analyzed using bootstrap analysis to calculate the mean and respective 95% CIs on the difference between the group means for each statistics (a test of equivalence). In the analyses, 10,000 balanced bootstrap samples were taken and the 95% CIs were calculated on the difference between the groups, so that if the CIs spanned zero, there was no significant difference ($P=0.05$).

The LCC statistics were used to measure intra-rater reliability for raters who repeated severity assessments with SADs. The inter-rater reliability was assessed based on the intra-class correlation coefficient (ICC) (Shrout and Fleiss, 1979), which, unlike most other correlation measures, operates on data structured as groups, rather than data structured as paired observations (e.g. Pearson correlation coefficient), which are only relative measures. For our ICC analysis, the model was assumed to be two-way, with absolute agreement and single measures (Shrout and Fleiss, 1979). The effect of the use of SADs on the

inter-rater reliability for each assessment time was measured based on the confidence interval of the ICC estimated by the model.

All statistical analyses were calculated in R (R Core Team, 2013). The `epi.ccc` function of the `epiR` package (Stevenson, 2012) was used to obtain Lin's CC statistics. The built-in `boot.sample` R function was used for the hypothesis test. The ICC was calculated with the `icc` function of the `irr` R package (Gamer *et al.*, 2012).

Results

Effect of SADs and rater experience on accuracy and precision. The use of the SADs resulted in improved concordance (ρ_c), accuracy (C_b) and precision (r), and reduced absolute error of the estimates compared to unaided assessments (irrespective of experience) over all raters (Fig. 5.3). Estimates of severity with SADs were closer to the concordance line compared to estimates without use of SADs (Fig. 5.3 A, B). Absolute errors decreased with the use of SADs, with most values falling within $\pm 20\%$. Both without and with the use of SADs, the absolute errors of the estimates were mostly negative, suggesting a tendency to underestimate severity, particularly noticeable in the range 40 to 80% (Fig. 5.3 C, D).

Lin's CC statistics improved significantly with the use of SADs for the group of inexperienced raters (Table 5.1), with better accuracy ($C_b=0.93$ and 0.98 without and with SADs, respectively), precision ($r=0.88$ without and $r=0.96$ with SADs, respectively) and agreement (ρ_c without SADs= 0.82 ; ρ_c with SADs= 0.95 , respectively). However, no improvements in Lin's CC statistics were found when experienced raters used the SADs (Table 5.1).

The greatest improvement in accuracy of estimates with SADs compared to without SADs was noted for the group of inexperienced raters (Fig. 5.4). The biggest gains in agreement, bias and precision were obtained for raters with the poorest estimates without the use of SADs (Fig. 5.4 A-C). Intriguingly, some experienced raters increased bias (gain was negative) thus resulting in reduced agreement when using the SADs compared to estimates initially made without the SADs (Fig. 5.4).

Rater experience had a significant effect on precision (r) but not the accuracy (C_b) for estimates made without SADs (Table 5.2). With the use of SADs, inexperienced raters were significantly more accurate and precise compared to experienced raters, especially during the second assessment using SADs. Accuracy (C_b), precision (r) and agreement (ρ_c) differed significantly between the experienced and inexperienced raters based on the bootstrap

analysis, with values, in the case of inexperienced raters in the range 0.97 to 0.99.

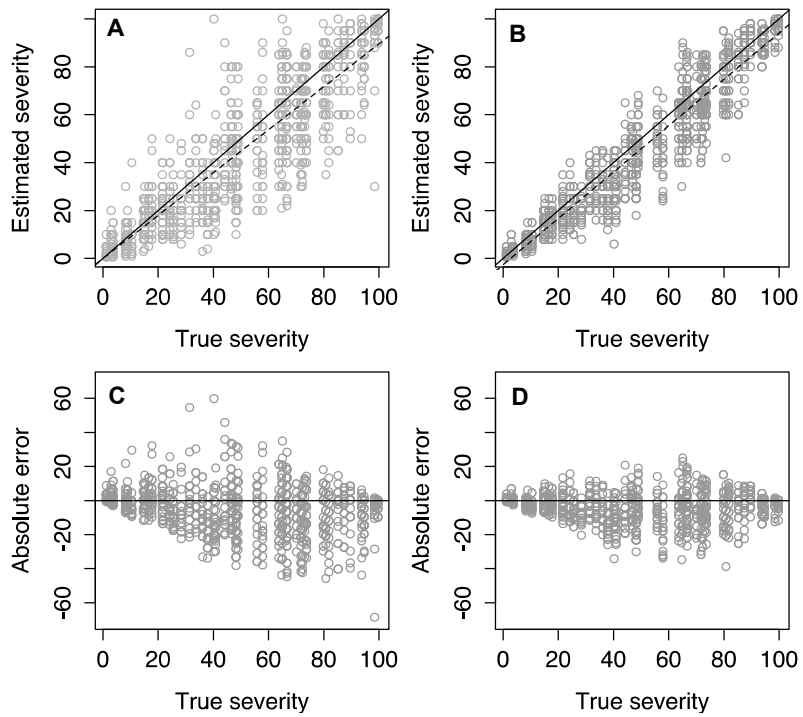

Figure 5.3. Relationship between the estimates and true severity (**A, B**) and the absolute error (estimate minus true severity) (**C, D**) of assessments of a set of 50 images of scab-diseased fruit of loquat by 20 raters without (**A, C**) and with (**B, D**) the use of a standard area diagrams (SADs). Dashed line (**A, B**) represents the regression line.

Table 5.1. Effect of use of SADs as an assessment aid on the bias, precision and overall agreement of estimates of scab severity on loquat fruit made by raters with or without experience in disease severity assessment

	LCC statistic	Means		95% CI ^a of the difference between means
		No SAD aid	With SAD aid	
Inexperienced	Scale-shift (ν) ^b	1.01	1.00	-0.059, 0.091
	Location-shift (μ) ^c	0.18	0.09	-0.120, 0.295
	Bias correction factor (C_b) ^d	0.93	0.98	-0.094, -0.014
	Correlation coefficient (r) ^e	0.88	0.96	-0.117, -0.052
	Concordance coefficient (ρ_c) ^f	0.82	0.95	-0.175, -0.089
Experienced	Scale-shift (ν)	1.04	0.99	-0.007, 0.106
	Location-shift (μ)	0.19	0.20	-0.133, 0.120
	Bias correction factor (C_b)	0.96	0.97	-0.032, 0.025
	Correlation coefficient (r)	0.95	0.95	-0.015, 0.008
	Concordance coefficient (ρ_c)	0.92	0.93	-0.042, 0.028

^a Bootstrap calculated difference between means and confidence intervals (CIs). If the CIs embrace zero, difference is not significant at the 5% level. Bold numbers represent significance of the difference.

^b Scale or slope shift relative to the perfect relationship (1=perfect relation between x and y).

^c Location or height shift relative to the perfect relationship (0=perfect relation between x and y).

^d Bias correction factor that measures how far the best-fit line deviates from a line at 45 degrees. No deviation from the 45 degree line occurs when $C_b=1$. C_b is calculated from ν and μ and is a measure of accuracy

^e Correlation coefficient (r) that measures precision

^f Lin's concordance correlation coefficient (ρ_c) combines both precision (r) and accuracy (C_b) ($\rho_c=r.C_b$) to measure agreement with the true value (Lin, 1989).

Inter-rater and intra-rater reliability. Inter-rater reliability, based on the intra-class correlation coefficient, was improved for inexperienced raters with use of SADs ($\rho=0.71$ without SADs and $\rho=0.93$ and $\rho=0.96$ for the first and second assessment using SADs, respectively) (Table 5.3). Experienced raters showed good inter-rater reliability ($\rho>0.94$) irrespective of the use of SADs.

Good intra-rater reliability was obtained by both experienced and inexperienced raters when estimates were made using the SADs ($\rho_c>0.92$). There was no effect of experience on intra-rater reliability (mean $\rho_c=0.95$ and 0.95 for inexperienced and experienced raters, respectively) (Table 5.4).

Table 5.2. Effect of rater experience on the bias, precision and overall agreement of estimates of scab severity on loquat fruit made by ten raters either unaided or aided by a standard area diagram (SAD)

Assessment	LCC variable	Means		95% CI ^a of the difference between means
		Not experienced	Experienced	
No SAD	Scale-shift (ν) ^b	1.01	1.04	-0.103, 0.053
	Location-shift (μ) ^c	0.18	0.19	-0.240, 0.211
	Bias correction factor (C_b) ^d	0.93	0.96	-0.078, 0.013
	Correlation coefficient (r) ^e	0.88	0.95	-0.108, -0.039
	Concordance coefficient (ρ_c) ^f	0.82	0.92	-0.151, -0.049
SAD first assessment	Scale-shift (ν)	1.00	0.99	-0.050, 0.066
	Location-shift (μ)	0.09	0.20	-0.200, -0.007
	Bias correction factor (C_b)	0.98	0.97	-0.001, 0.037
	Correlation coefficient (r)	0.96	0.95	-0.001, 0.015
	Concordance coefficient (ρ_c)	0.95	0.93	0.003, 0.048
SAD second assessment	Scale-shift (ν)	1.02	0.98	0.011, 0.071
	Location-shift (μ)	0.07	0.20	-0.212, -0.035
	Bias correction factor (C_b)	0.99	0.97	0.002, 0.043
	Correlation coefficient (r)	0.98	0.95	0.012, 0.031
	Concordance coefficient (ρ_c)	0.97	0.93	0.018, 0.068

^a Bootstrap calculated difference between means and confidence intervals (CIs). If the CIs embrace zero, difference is not significant at the 5% level. Bold numbers represent significance of the difference

^b Scale or slope shift relative to the perfect relationship (1=perfect relation between x and y)

^c Location or height shift relative to the perfect relationship (0=perfect relation between x and y)

^d Bias correction factor that measures how far the best-fit line deviates from a line at 45 degrees. No deviation from the 45 degree line occurs when $C_b=1$. C_b is calculated from ν and μ and is a measure of accuracy

^e Correlation coefficient (r) that measures precision

^f Lin's concordance correlation coefficient (ρ_c) combines both precision (r) and accuracy (C_b) ($\rho_c=C_b$) to measure agreement with the true value (Lin, 1989)

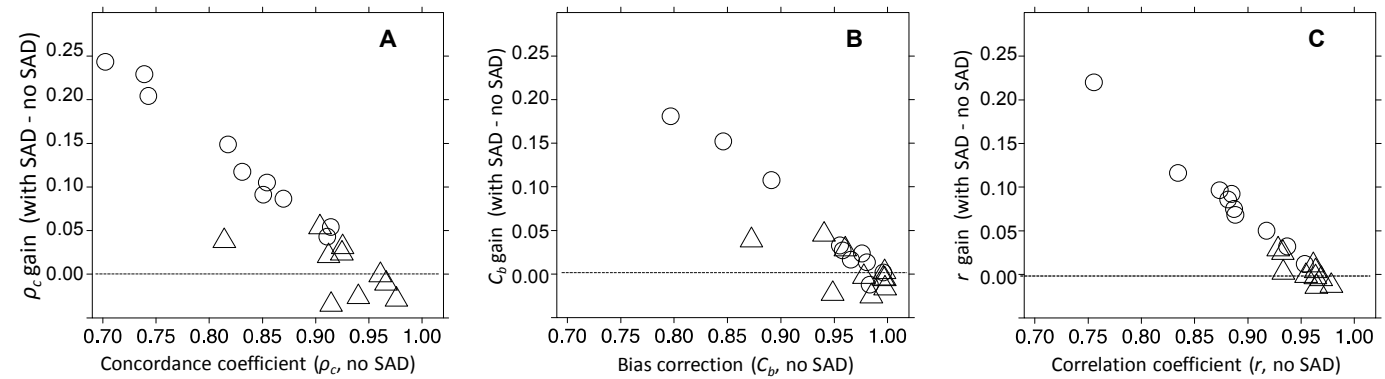

Figure 5.4. The relationship between gain (difference between the estimate with and without use of a standard area diagram, SAD) for measures of accuracy, precision and agreement of visual severity estimates made by 10 inexperienced (circles) and 10 experienced (triangles) raters for a set of 50 images of scab-diseased fruit of loquat (**A**, agreement, measured by Lin's concordance correlation coefficient; **B**, accuracy measured by the bias correction factor; and **C**, precision, measured by the correlation coefficient).

Table 5.3. Inter-rater reliability (reproducibility) of visual estimates of scab severity on 50 loquat fruit by 20 raters either unaided (one-time assessment) or aided by SADs measured by the intra-class correlation coefficient (ICC). Two assessments were made using the SADs with a two-week interval.

Assessment	Intra-class correlation coefficient, ρ (95% CI)	
	Inexperienced raters (n=10)	Experienced raters (n=10)
No SAD	0.71 (0.59 - 0.80)	0.94 (0.91 - 0.96)
SAD aid 1 st assessment	0.93 (0.91 - 0.95)	0.94 (0.92 - 0.96)
SAD aid 2 nd assessment	0.96 (0.94 - 0.97)	0.95 (0.93 - 0.97)

Table 5.4. Intra-rater reliability (repeatability), measured by Lin's concordance correlation coefficient (ρ_c), for estimates of severity on 50 diseased loquat fruit by two groups of ten raters either with or without experience but using SADs during two consecutive SAD-aided assessments

Rater	Experience	
	No (n=10)	Yes (n=10)
1	0.97	0.97
2	0.95	0.95
3	0.97	0.97
4	0.97	0.97
5	0.94	0.94
6	0.97	0.97
7	0.95	0.94
8	0.94	0.94
9	0.92	0.92
10	0.97	0.97
Mean	0.955	0.954
Diff. between means ^a	0.001 (0.0077)	
95%CI of the difference ^b	-0.0142, 0.0162	

^a Bootstrap calculated difference between means.

^b If the CIs embrace zero, difference is not significant at $P=0.05$.

Discussion

The SAD set of eight black and white loquat scab diseased fruit images covered the range 2% to 98% severity and exhibited typical symptom patterns of loquat scab (small spots initially, that expand and coalesce covering almost the entire fruit surface; Sánchez-Torres *et al.*, (2009)). This severity range is commonly observed in cv. Algeria, the most widely grown cultivar in Spain and known to be highly susceptible to *F. eriobotryae* (Sánchez-Torres *et al.*, 2009). More realistically, the diagrams, although depicting only the side view of the fruit, display the typical prominent lesions at the peduncle region of more severely affected fruit, a pattern commonly associated with splash-dispersed pathogens (Bock *et al.*, 2011a).

The number of diagrams (eight) used to depict the severity range (2 to 98%) is similar to the number used in SADs of other pathosystems, which is of practical use (Corrêa *et al.*, 2009, Yadav *et al.*, 2012). The severity increment was nonlinear because more reference values (five) were placed in a range where loquat scab severity levels are typically more common (<50%) (results of this study; Sánchez-Torres *et al.*, 2009).

Although the SADs improved the accuracy and reliability of the estimates by inexperienced raters, there was an overall tendency to underestimate severity in the 40 to 80% range of severity. Most reports in the literature show that inexperienced raters tended to overestimate severity, especially at lower severities (<20%) (Forbes and Korva 1994; Diaz *et al.*, 2001; Leite and Amorim, 2002; Spósito *et al.* 2004; Bock *et al.* 2008, 2009). However, this is not the first study to report a slight tendency of raters to underestimate severity at mid to high disease severity (Michereff *et al.*, 1998, 2000; Gomes *et al.*, 2004; Spolti *et al.*, 2011). This underestimation could be because of the disease pattern on the fruit. Spolti *et al.* (2011) discussed underestimation of severity of sooty blotch and flyspeck disease as possibly related to the clustering of small lesions that could not be discerned easily by raters. Moreover, Sherwood *et al.* (1983) also demonstrated that illusions in assessment due to lesion size and number resulted in error. If two leaves had similar severity but one had many small lesions as compared to a few larger lesions, the visual estimate for the leaf with the greater number of lesions exceeded that for the leaf with the fewer (but larger) lesions. Although this situation related to overestimation, equivalent illusions may be a cause of underestimates we observed with loquat scab. In the case of loquat scab, clustering of lesions on the fruit surface is typical of the disease (Sánchez-Torres *et al.*, 2009), reducing the number of diseased areas at higher values of severity. The clustering of disease might affect how the symptom severity is perceived. Furthermore, the fact that the SADs have only

three severity values >50% might also have contributed to greater negative bias in that range.

The effect of rater experience on the accuracy and precision of estimates, without or with SADs, has been studied previously (Godoy *et al.*, 2006; Pedroso *et al.*, 2011; Yadav *et al.*, 2013). In an evaluation of SADs for pecan scab caused by *Fusicladium effusum* (Yadav *et al.*, 2013), experienced raters who showed low bias and high accuracy and precision of estimates without SADs, did not respond as much as the inexperienced raters to the use of SADs. The results of the current study confirmed that experienced raters did not benefit significantly from the use of SADs.

Significant improvements in reliability of the estimates, both within and among raters, were noticed for estimates made with the SADs, in agreement with previous reports (Godoy *et al.*, 2006; Yadav *et al.*, 2013). The SADs developed in our study proved to be useful for obtaining more accurate, precise and reliable estimates of loquat scab for inexperienced, rather than experienced raters, and will be a valuable tool for raters as an aid in estimating scab severity in epidemiological studies or for monitoring disease for decision-making purposes.

Acknowledgements

This work was funded by Cooperativa Agrícola de Callosa d'En Sarrià (Alicante, Spain). Financial support was provided by CAPES (Brazil) for S. J. Michereff at the Universidad Politécnica de Valencia (Spain) and is gratefully acknowledged. The authors thank colleagues and students who assessed the diseased fruits images.

Chapter 6

Development and validation of a weather-based model for predicting infection of loquat fruit by *Fusicladium eriobotryae*

Elisa González-Domínguez¹, Josep Armengol¹, Vittorio Rossi².

¹Instituto Agroforestal Mediterráneo, Universidad Politécnica de Valencia, Camino de Vera s/n, 46022-Valencia, Spain.

²Istituto di Entomologia e Patologia vegetale, Università Cattolica del Sacro Cuore, 29122 Piacenza, Italy.

Abstract

A mechanistic, dynamic model was developed to predict infection of loquat fruit by conidia of *Fusicladium eriobotryae*, the causal agent of loquat scab. The model simulates scab infection periods and their severity through the sub-processes of spore dispersal, infection, and latency (i.e., the state variables); change from one state to the following one depends on environmental conditions and on processes described by mathematical equations. Equations were developed using published data on *F. eriobotryae* mycelium growth, conidial germination, infection, and conidial dispersion pattern. The model was then validated by comparing model output with three independent data sets. The model accurately predicts the occurrence and severity of infection periods as well as the progress of loquat scab incidence on fruit (with concordance correlation coefficients >0.95). Model output agreed with expert assessment of the disease severity in seven loquat-growing seasons. Use of the model for scheduling fungicide applications in loquat orchards may help optimise scab management and reduce fungicide applications.

Introduction

Scab, caused by the plant-pathogenic fungus *Fusicladium eriobotryae* (Cavara) Sacc., is the main disease affecting loquat in Spain and in the whole Mediterranean basin (Sánchez-Torres *et al.*, 2009; Gladioux *et al.*, 2010). The fungus affects young twigs, leaves and fruits, causing circular olive-colored spots that, on fruits, reduce their commercial value (Sánchez-Torres *et al.*, 2009). *Fusicladium* spp. are the anamorphic stages of the ascomycete genus *Venturia* but the sexual stage of *F. eriobotryae* has never been found in nature (Gladioux *et al.*, 2010).

Although loquat scab is a well-known problem in the areas where loquat trees are cultivated, the biology of *F. eriobotryae* and the epidemiology of the disease have been seldom studied (Prota, 1960; Salerno, 1971a; Ptskialadze, 1968; González-Domínguez *et al.*, 2013b, 2014b, 2014d; Sánchez-Torres *et al.*, 2009). These studies have depicted *F. eriobotryae* as a highly rain-dependent pathogen that requires mild temperatures and long wet periods to infect loquat trees.

Environmental requirements for infection and the dispersion patterns have been studied in detail for other *Venturia* spp., such as *Venturia inaequalis* (Becker and Burr, 1994; Hartman *et al.*, 1999; Holb *et al.*, 2004; Rossi *et al.*, 2003; Stensvand *et al.*, 1997; MacHardy, 1996; James and Sutton, 1982; Boric, 1985), *V. nashicola* (Li *et al.*, 2005, 2003; Lian *et al.*, 2007; Umemoto, 1990), *V. pyrina* (Rossi *et al.*, 2009; Spotts and Cervantes, 1991; Spotts *et al.*, 1994; Villalta *et al.*, 2000; 2000b), *F. carpophilum* (Lan and Scherm, 2003; Lawrence and Zehr, 1982), *F. effusum* (Gottwald and Bertrand, 1982; Gottwald, 1985; Latham, 1982), and *F. oleagineum* (De Marzo *et al.*, 1993; Lops *et al.*, 1993; Obanor *et al.*, 2010, 2008b; Viruega *et al.*, 2013, 2011). These studies have been used to elaborate epidemiological models for some of these pathogens including *V. pyrina* (Eikemo *et al.*, 2011), *V. nashicola* (Li *et al.*, 2007), *V. inaequalis* (Rossi and Bugiani, 2007; Xu *et al.*, 1995), *F. oleagineum* (Roubal *et al.*, 2013), and *F. effusum* (Payne and Smith, 2012). For *V. inaequalis*, the use of epidemiological models to schedule fungicide applications has reduced the number of treatments (Trapman and Polfliet, 1997; Holb *et al.*, 2003; Jamar *et al.*, 2010; Giosuè *et al.*, 2010). To date, no epidemiological model has been developed for *F. eriobotryae*.

Disease modelling is an important step towards the implementation of sustainable agriculture (Rossi *et al.*, 2012; Gent *et al.*, 2013). Since the 1990s, modern crop production has focused on the implementation of less intensive systems with reduced inputs of fertilizers and pesticides, and reduced use of natural resources (Rossi *et al.*, 2012). Sustainable agriculture has its roots in Integrated Pest Management (IPM) (Boller *et al.*, 2004). IPM concepts originated as a reaction to the disruption of agro-ecosystems caused by massive applications of broad-spectrum pesticides in the middle of the last century (Rossi *et al.*, 2012) and also because of concern about the effects of excessive pesticide use on human health (Alavanja *et al.*, 2004).

In Europe, the implementation of IPM has been legislatively mandated in recent years because of Directive 2009/128/CE regarding sustainable use of pesticides. Among other actions, the Directive encourages EU Member States to promote low pesticide-input pest control and the implementation of tools for pest

monitoring and decision making, as well as advisory services (Art. 14 of the Directive). De facto, the “sustainable use” directive has made IPM mandatory in European agriculture as of 2014. As a consequence, there is an increased interest in the development and use of plant disease models to improve the timing of pesticide applications and to thus limit unnecessary treatments (Brent and Hollomon, 2007a; Rossi *et al.*, 2012; Shtienberg, 2013).

Our aims in this paper were (i) to develop a mechanistic, dynamic model to predict infection of loquat fruit by the scab fungus *F. eriobotryae*, and (ii) to evaluate the model against three independent data sets. The model was elaborated based on the principles of “systems analysis” (Leffelaar, 1993; Rossi *et al.*, 2010) and by using recent data on the biology and epidemiology of *F. eriobotryae* obtained under environmentally controlled and field conditions (González-Domínguez *et al.*, 2013b, 2014d; Sánchez-Torres *et al.*, 2009).

Model development

Based on the available information (Prota, 1960; Salerno, 1971a; Ptskialadze, 1968; González-Domínguez *et al.*, 2013, 2014b, 2014d; Sánchez-Torres *et al.*, 2009), the life cycle of *F. eriobotryae* under the Mediterranean climate is described in Fig. 6.1. The fungus overwinters in lesions on branches and leaves and on mummified fruits that remain in the tree after harvest; during summer, high temperatures and low humidity may prevent sporulation on these lesions. Under favorable conditions in the fall, the conidia produced by the overwintering lesions serve as the primary inoculum and infect young leaves or loquat fruits. Conidia are dispersed by splashing rain to nearby fruits and leaves; with suitable temperature and wetness, conidia germinate and penetrate the tissue, probably directly through the cuticle or through stomata. Once infection has occurred and if the temperature is favorable, the fungus grows under the cuticle; conidiophores then erupt through the cuticle and produce new conidia. These conidia cause secondary infections during the entire fruiting season as long as rains disperse them and as long as temperature and wetness duration permit conidial germination, infection, and lesion growth.

Model description. The relational diagram of the model for loquat fruit infection by *F. eriobotryae* is shown in Fig. 6.2, and the acronyms are explained in Table 6.1. The time step of the model is 1 hour.

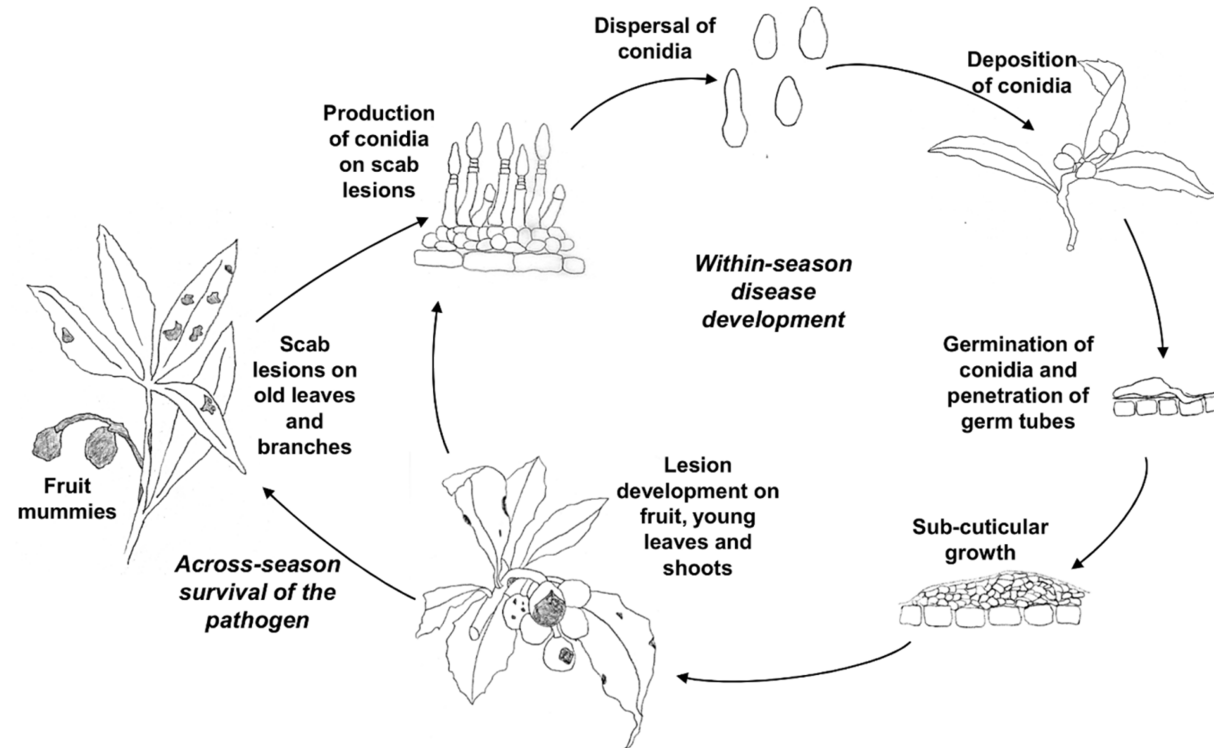

Figure 6.1. Disease cycle of loquat scab caused by *Fusicladium eriobotryae*.

The model starts at fruit set and ends at harvest because fruits are assumed to be always susceptible to infection. The model considers the lesions from the previous season on branches, old leaves, and mummified fruits as the sources of primary inoculum. Because the abundance of these lesions in an orchard may vary depending on several conditions—on, for instance, the level of disease or the fungicide treatments in the previous season—and because it is difficult to quantify these lesions, the model assumes that overwintered forms are present in the orchard and that they hold conidia at fruit set and onwards. The model considers that any measurable rain (i.e., $R \geq 0.2$ mm in 1 hour) causes dispersal and deposition of conidia on loquat fruit (González-Domínguez *et al.*, 2014d) and triggers an infection process that potentially ends with the appearance of scab symptoms. Each site on the fruit that is occupied by a conidium or conidia is considered a potential infection site and is referred to as a lesion unit (LU). During the infection process, infection on any LU can fail because conidia may fail to germinate or may germinate but then die because of unfavorable conditions. Therefore, the proportion of LUs that become scabbed at the end of the infection process may be less than that occupied by splashing conidia at the beginning of the process.

The model predicts the progress of infection on single LUs. An LU is initially healthy (LUH) but then becomes occupied by: ungerminated conidia (LUUC) at the time of conidial dispersal; germinated conidia (LUGC) at the time of conidial germination; latent infection after penetration (i.e., hyphae are invading the fruit cuticle; LULI); and visible and sporulating scab lesions at the end of latency (LUVI). Both LUUC and LUGC can fail to progress if ungerminated or germinated conidia die; these LUs then return to being LUHs because they can start a new infection process whenever new conidia are splashed on them. In the example of Fig. 6.3, 25 LUHs become LUUCs at the time of conidial deposition. In the second step, conidia germinate on 10 LUs, which therefore become LUGCs, 11 LUs return to being LUHs because the conidia splashed on them died before germination, and 4 LUs become LUUCs because their conidia remained alive but ungerminated. In the third step, 5 LUs that were occupied by germinated conidia become infected (i.e., become LULIs), 3 return to being LUHs because the germinated conidia died, and 2 return to being LUHs because the ungerminated conidia died; also in the third step, one LU changes from LUUC to LUGC because the conidia deposited on it germinated. In the fourth step (i.e., at the end of latency), 4 LUs return to being LUHs because of the death of ungerminated or germinated conidia, and 5 LUs show disease symptoms (i.e., become LUVIs).

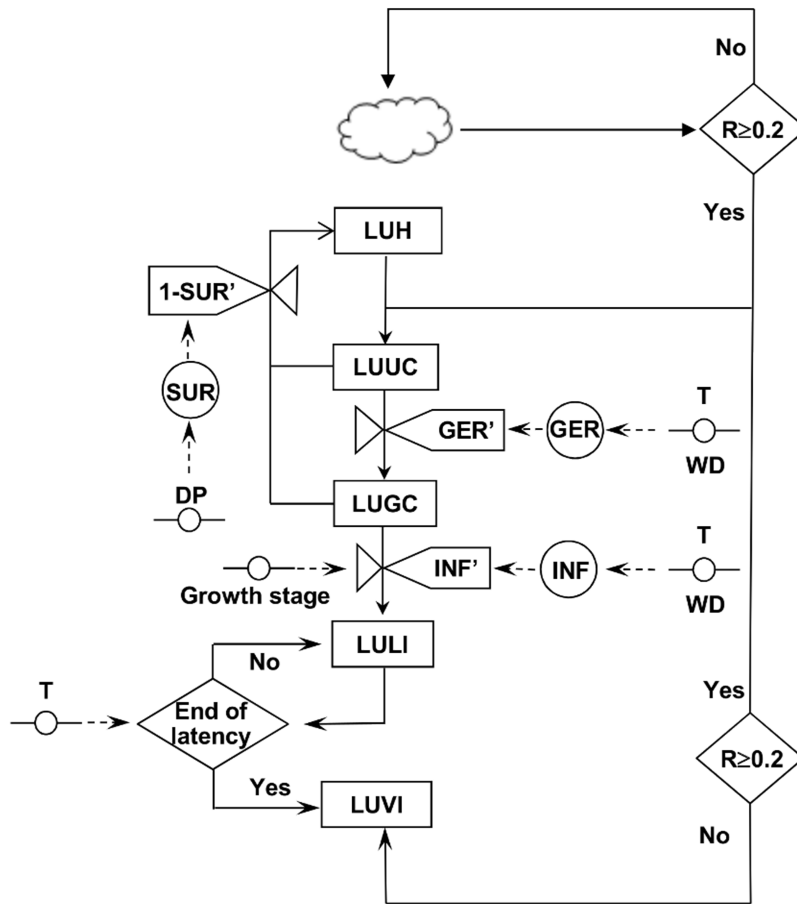

Figure 6.2. Relational diagram showing how the model simulates infection by *Fusicladium eriobotryae*. Legend: (□) state variable, (→) flux and direction of states, (→) flux and direction of information, (—○) parameter, (○) intermediate variable, (◇) switch, (☁) outgoing variable, (▭) valve in a flux (rate). See Table 6.1 for acronym explanation

Table 6.1. List of variables used in the model.

Acronym	Description	Unit
<i>T</i>	Air temperature	°C
<i>RH</i>	Relative humidity	%
<i>R</i>	Rainfall	mm
<i>VPD</i>	Vapour pressure deficit	hPa
<i>WD</i>	Wetness duration	hours
<i>Teq</i>	Temperature equivalent	°C
<i>LUH</i>	Unit of loquat fruit surface without conidia of <i>F. eriobotryae</i>	Number (0-1)
<i>LUUC</i>	Unit of loquat fruit surface with ungerminated conidia of <i>F. eriobotryae</i>	Number (0-1)
<i>LUGC</i>	Unit of loquat fruit surface with germinated conidia of <i>F. eriobotryae</i>	Number (0-1)
<i>LULI</i>	Unit of loquat fruit surface with latent infection by <i>F. eriobotryae</i>	Number (0-1)
<i>LUVI</i>	Unit of loquat fruit surface with visible scab lesions	Number (0-1)
<i>GER</i>	Cumulated conidial germination	Number (0-1)
<i>INF</i>	Cumulated infection	Number (0-1)
<i>SUR</i>	Cumulated conidial survival	Number (0-1)
<i>GER'</i>	Germination rate (first derivative of GERM)	Number (0-1)
<i>INF'</i>	Infection rate (first derivative of INF)	Number (0-1)
<i>SUR'</i>	Survival rate (first derivative of SUR)	Number (0-1)
<i>C</i>	Correction factor	Number (0-1)
<i>DD</i>	Degree days	Number

At any dispersal event on hour h , the model considers that $LUUC_h=1$. The rate at which $LUUC_h$ advances to $LUGC_h$ depends on a germination rate (GER'), and the rate at which $LUGC_h$ advances to $LULI_h$ depends on an infection rate (INF') (Fig. 6.2). Both GER' and INF' are influenced by temperature (T in °C) and wetness duration (WD , in hours) (i.e., free water on the surface of the loquat fruit) caused by either rain or dew.

Fruit surfaces are assumed to be wet on any hour when $R_h > 0$ mm, or $RH_h > 89\%$, or $VPD_h < 1$, where VPD is the vapour pressure deficit (in hPa) calculated using T_h and RH_h , following Buck (1981). The rate at which $LUUC_h$ and $LUGC_h$ returns to LUH_h depends on a survival rate (SUR'), which depends in turn on the length of the dry period (DP), i.e., the number of hours with no wetness on the fruit surface (Fig. 6.2).

GER' , INF' , and SUR' are calculated at hourly intervals by using the first derivative of the following equations (González-Domínguez *et al.*, 2013b):

$$GER = 116.249 \times Teq^{4.347} \times (1 - Teq^{2.882}) \times e^{\left[4.704 \times e^{(0.376 \times WD)}\right]} \quad (1)$$

$$INF = 4.961 \times Teq^{1.700} \times (1 - Teq)^{20.771} \times e^{\left[4.704 \times e^{(0.087 \times WD)}\right]} \quad (2)$$

$$SUR = -0.165 \times \ln(DP) + 0.879 \quad (3)$$

where: GER , INF , and SUR are the cumulated curves of conidial germination, infection, and conidial survival, respectively; Teq is the temperature equivalent in the form $Teq = (T - T_{min}) / (T_{max} - T_{min})$ where: T is the temperature regime, $T_{min} = 0^\circ\text{C}$ and $T_{max} = 35^\circ\text{C}$ in equation (1), and $T_{min} = 0^\circ\text{C}$ and $T_{max} = 25^\circ\text{C}$ in equation (2); WD = number of consecutive hours with wetness; DP = number of consecutive hours with no wetness. When $DP = 0$, $SUR' = 1$.

At any time of the infection progress (i):

$$LUGC_h = \sum_{i=1}^{i=t} (GER'_i \times SUR'_i \times C_i)$$

$$LUUC_h = \sum_{i=1}^{i=t} \left[(1 - LUGC_h)_i \times SUR'_i \times C_i \right]$$

$$LULI_h = \sum_{i=1}^{i=t} (INF'_i)$$

$$LUGC_h + LUUC_h + LULI_h + LUH_h = 1$$

where C is a correction factor ($C = 1 - LULI_h$)

Any infection period triggered by a conidial dispersal event ends when no viable conidia are present on any LUs, exactly when $LUUC \leq 0.01$. An example of model output for a single infection period is shown in Fig. 6.4.

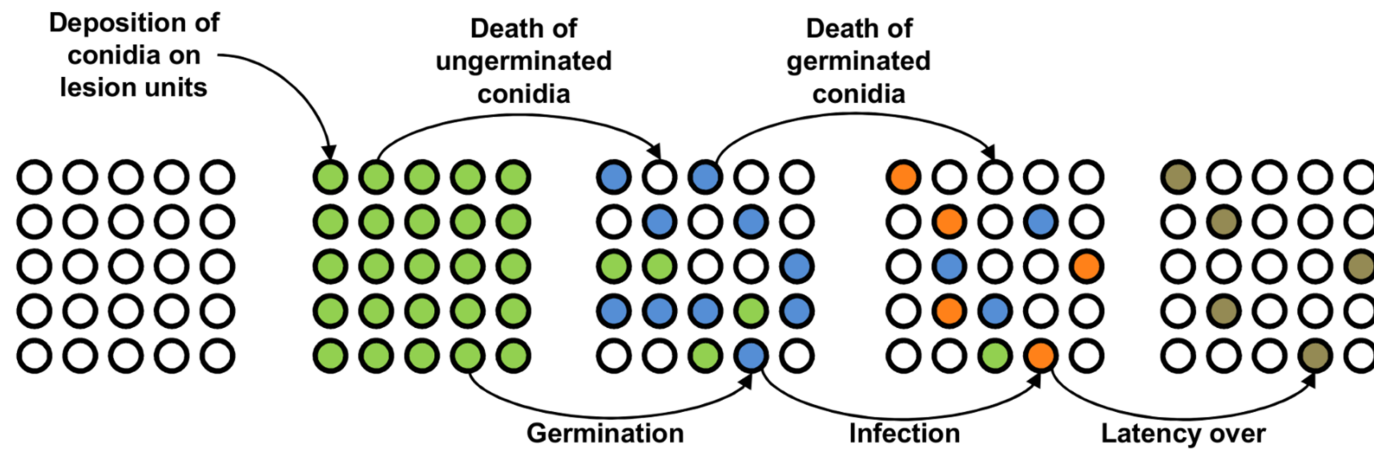

Figure 6.3. Schematic representation of the infection process in terms of lesion units (LU). Each circle represents an LU that can have different states: healthy (LUH, in white), occupied by ungerminated conidia (LUUC, in green), occupied by germinated conidia (LUGC, in blue), with latent infection (LULI, in orange), or with visible scab (LUVI, in brown). Deposition, death of conidia, germination, infection, and latency progress are the phenomena that define the change of LUs from one state to another. In the example presented and in relative units, $LUHC=1$ at time zero and $LUUC=1$ at the first time step (deposition of splashing conidia). At the second time step: $LUUC+LUGC+LUH=0.16+0.40+0.44=1$. At the third time step: $LUUC+LUGC+LULI+LUH=0.12+0.04+0.20+0.64=1$. At the fourth time step: $LUVI+LUH=0.20+0.80=1$. Therefore, at the end of the infection process, 20% of the lesion units became infected in this example.

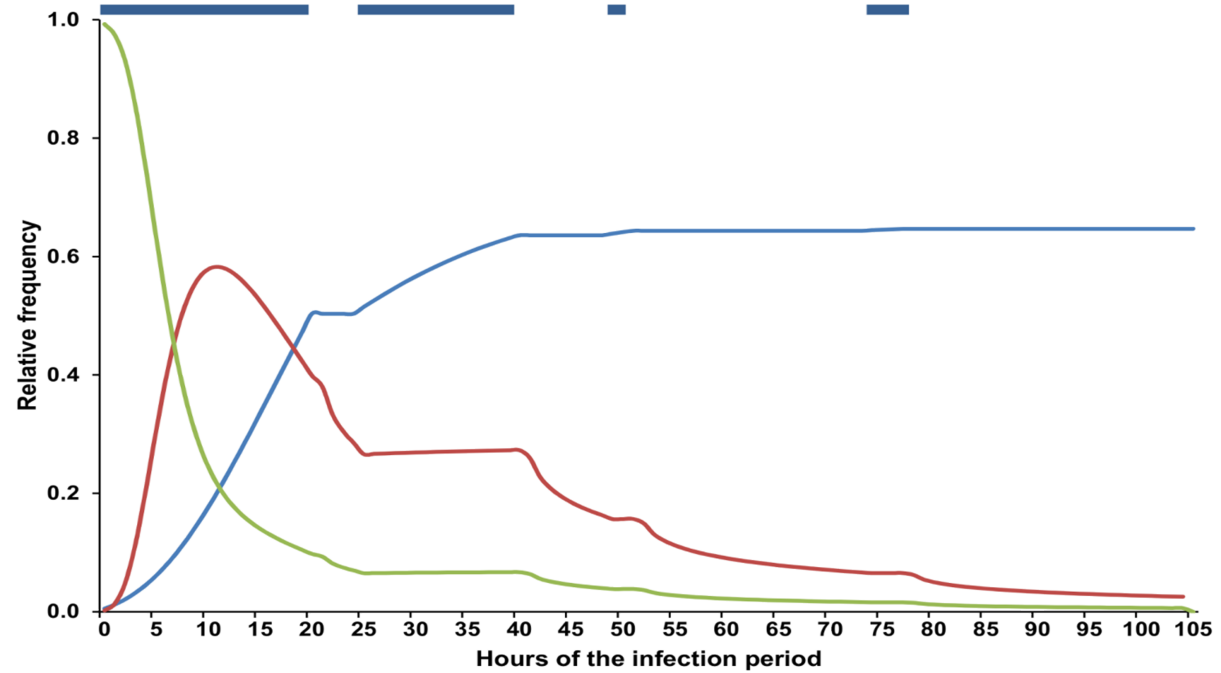

Figure 6.4. Dynamics of lesion units (LUs) during an infection period of *Fusicladium eriobotryae*. The graph shows the relative frequency of LUs occupied by ungerminated conidia (LUUC, in green), germinated conidia (LUGC, in red), and latent infections (LULI, in blue). Blue bars at the top indicate hours with free water on the fruit surface. An infection period starts when a rain event splashes conidia on LUs and ends when no viable conidia are present on any LUs, i.e., when $LUUC \leq 0.01$.

The model considers that any further rain event causes further dispersal and deposition of conidia if >5 hours have passed after the previous dispersal event. This is the time required by a lesion to produce new conidia.

Model output. The model output consists of: (i) the available inoculum on fruits (i.e., the frequency of LUs with ungerminated conidia on each day) as a measure of the potential for infection to occur; (ii) the dynamics of *LULI* for each infection process; and (iii) the seasonal dynamics of the accumulated values of *LULI* ($\Sigma LULI$) as an estimate of the disease in the orchard.

Examples of model output for the 2011 and 2012 loquat growing seasons are shown in Fig. 6.5 and 6.6, respectively. The output is based on the weather data registered by a weather station of the Regional Agrometeorological Service (<http://riegos.ivia.es/>) located in Callosa d'En Sarrià, Alicante Province, southeastern Spain.

Model validation

Three data sets were used to validate the model: (i) incidence of affected fruits in a loquat orchard during growing seasons 2011 and 2012; (ii) disease occurrence on loquat fruits in single-exposure experiments in 2013; and (iii) expert assessment of the disease severity in seven loquat growing seasons.

To operate the model, hourly values of air temperature (*T*, °C), relative humidity (RH, %), and total rainfall (*R*, mm) were registered by the weather station of Callosa d'En Sarrià, which is ≤ 3.5 km from the orchards considered for validation.

Predicted vs. observed disease incidence in orchards. In data set (i), observations were carried out in a loquat orchard in Callosa d'En Sarrià, Alicante Province, southeastern Spain. Details on these data have been previously published (González-Domínguez *et al.*, 2014d). Briefly, fruits from four shoots of each of 46 loquat trees were assessed weekly, and disease incidence was expressed as the percentage of fruits with scab symptoms. The disease incidence was lower in 2011 than 2012, with 27.3% and 97.6% of fruits affected by loquat scab at harvest, respectively (González-Domínguez *et al.* 2014d). This difference in disease incidence may be related to the fact that the orchard was treated with fungicides for scab control in 2010 but not in 2011 or 2012. Given that the inoculum sources for fruit infection in 2011 was very low because of effective disease control in 2010, a correction factor for LUUC was applied for the infection processes initiated in January 2011, i.e., LUUC=0.1 instead of =1 in January 2011.

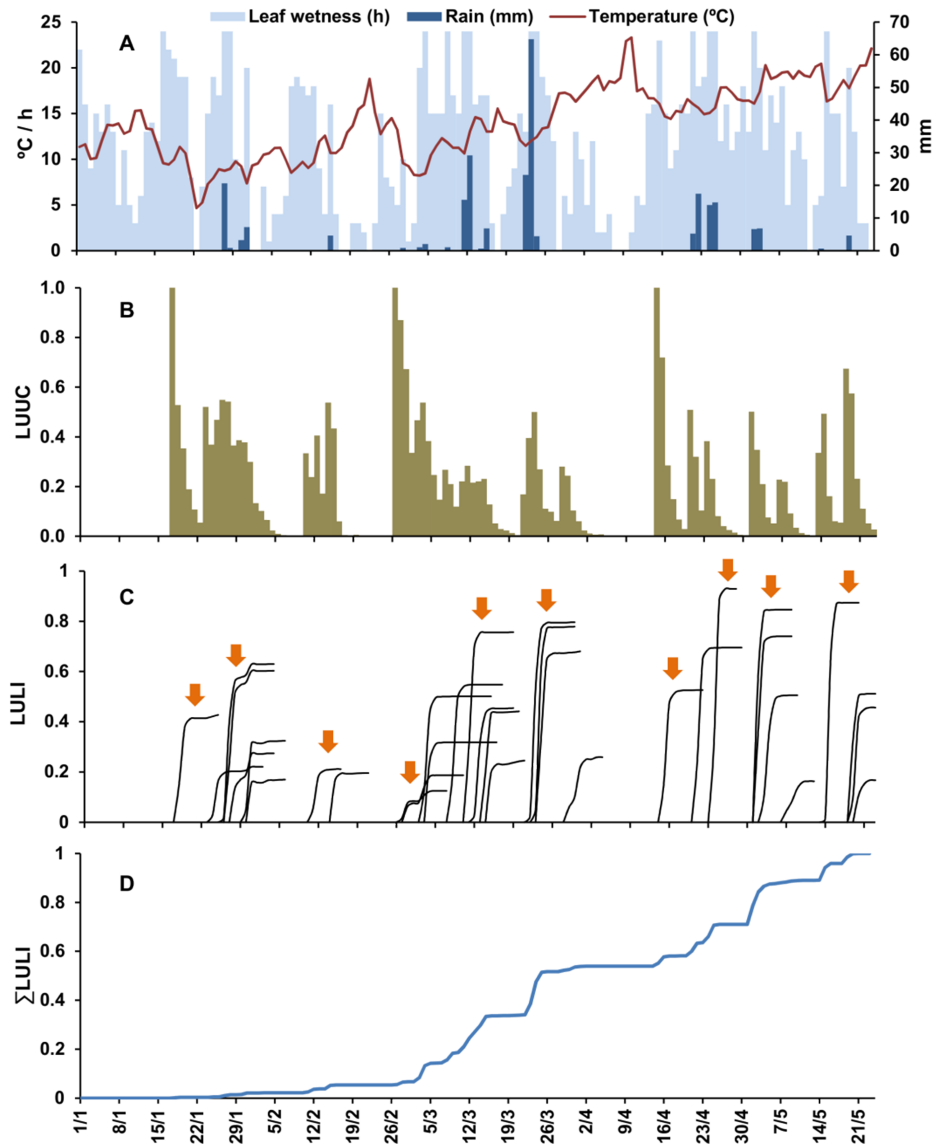

Figure 6.5. Weather data and model output in 2011. **A:** daily weather data; **B:** predicted frequency (%) of lesion units (LUs) with ungerminated conidia; **C:** predicted increase of LUs with latent infections (LULIs) for each infection period (arrows represent clusters of infection periods, clustering is based on an interval of at least 5 days between the beginning of two consecutive clusters); **D:** predicted seasonal dynamics of the cumulative values of LULI (Σ LULI).

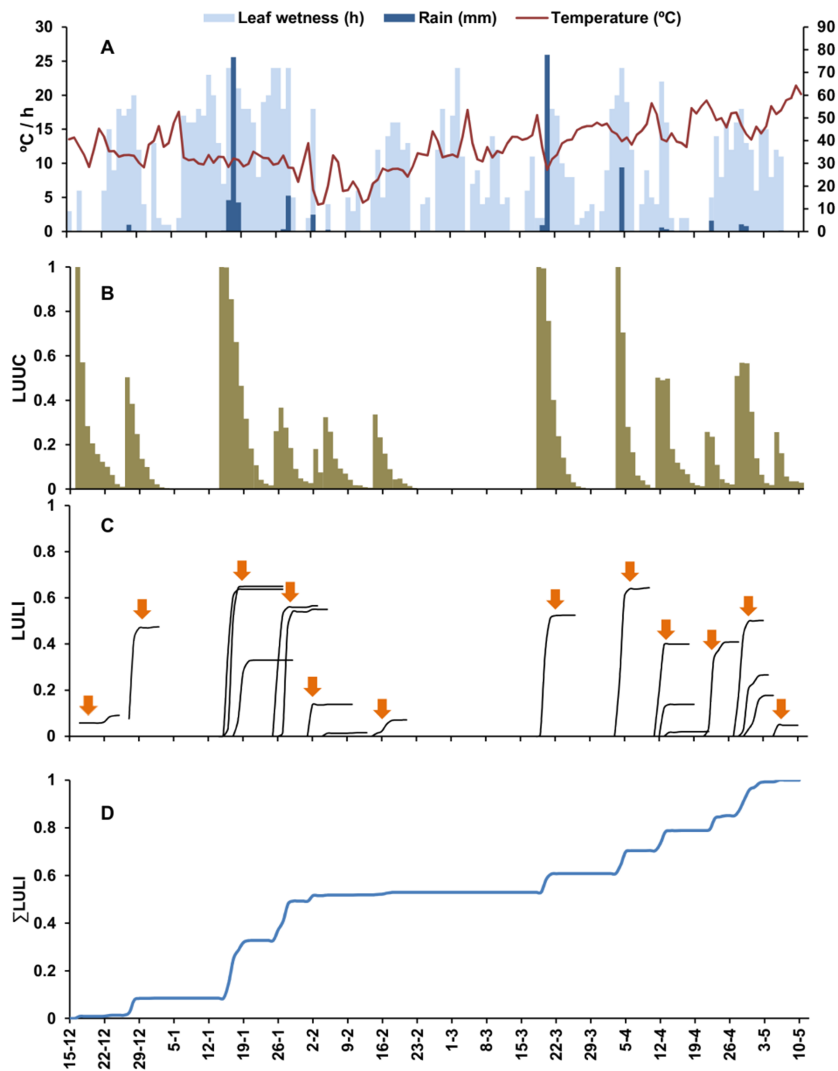

Figure 6.6. Weather data and model output in 2012. **A:** daily weather data; **B:** predicted frequency (%) of lesion units (LUs) with ungerminated conidia; **C:** predicted increase of LUs with latent infections (LULIs) for each infection period (arrows represent clusters of infection periods, clustering is based on an interval of at least 5 days between the beginning of two consecutive clusters); **D:** predicted seasonal dynamics of the cumulative values of LULI (Σ LULI).

Model validation was performed by comparing Σ LULI with observed data of disease incidence. Because there is a time lag (i.e., a latency period) between the predicted disease (as Σ LULI) and the disease incidence estimated in the orchard (DI), DI was shifted back by one latency period for comparison between predicted and observed disease. Sanchez-Torres *et al.* (2009) observed a latency period of 21 days at a constant temperature of 20°C, which is a degree-day accumulation (DD base 0°C) of 420. Therefore, DI was shifted back by either 21 days or 420 DD. To calculate the DD, the average temperature of each day was considered with base temperature of 0°C.

Predicted vs. observed disease incidence in single-exposure experiments.

In data set (ii), data were collected in an abandoned loquat orchard in Callosa d'En Sarrià from 4 February to 15 April 2013. On 25 January, 200 random shoots bearing fruits were covered with water-resistant paper bags (one shoot per bag) to prevent deposition of rain-splashed conidia. On 4 February, 10 random bags were opened to receive splashed inoculum; after seven additional days, the bags were closed again. Ten other randomly selected bags were opened on 11 February and closed again 7 days later. This operation was repeated until nine groups of shoots had been sequentially exposed to rain. At the end of the experiment (15 April 2013), disease incidence (percentage of fruits affected by loquat scab) and severity were assessed in each group of shoots. Disease severity refers to the percentage of fruit area covered by scab lesions and was measured as described by González-Domínguez *et al.* (2014b).

Model validation was performed by comparing the model output in the week when a group of shoots was exposed to splashing rain with final disease severity in that group.

Expert assessment. For data set (iii), Esteve Soler (technical advisor of the 'Cooperativa Agrícola de Callosa d'En Sarrià') was asked to provide a subjective estimate of the severity (low, medium, or high) of loquat scab in the area for eight growing seasons (from 2005/2006 to 2012/2013). Mr. Soler's estimates were based on his extensive experience in managing loquat orchards, on his scouting activities in the orchards of the cooperative, and on the number of fungicide treatments that were required to control the disease in the area.

For each season, the model was operated from 1 November to 31 March, and the numbers of disease outbreaks predicted by the model were counted. A disease outbreak was defined as $\Sigma LULI > 0.1$ in 1 day, when no outbreaks were predicted in the previous 5 days. Average and standard error of the number of predicted outbreaks were calculated for each category (low, medium, or high) of scab severity derived from the expert assessment.

Data analysis. Linear regression was used to compare the predicted and observed data of data sets (i) and (ii). To make data homogeneous, $\Sigma LUVI$ values at the time of each disease assessment in the orchards were rescaled to the $\Sigma LUVI$ at the end of the season; disease incidence was also rescaled to the final disease incidence. A *t*-test was used to test the null hypotheses that "a" (intercept of regression line) was equal to 0 and that "b" (slope of regression line) was equal to 1 (Teng, 1981). The distribution of residuals of predicted versus observed values was examined to evaluate the goodness-of-fit. The concordance correlation coefficient (CCC) was calculated as a measure of model accuracy (Madden *et al.*, 2007); CCC is the product of two terms: the Pearson product-moment correlation coefficient between observed and predicted values and the coefficient C_b (bias estimation factor), which is an indication of the difference between the best fitting line and the perfect agreement line (CCC=1 indicates perfect agreement). The following indexes of goodness-of-fit were also calculated (Nash and Sutcliffe, 1970): NS model-efficacy coefficient, which is the ratio of the mean square error to the variance in the observed data, subtracted from unity (when the error is zero, NS=1, and the equation provides a perfect fit); the W index of agreement which is the ratio between mean square error and total potential error (W=1 represents a perfect fit); model efficiency (EF) which is a dimensionless coefficient that takes into account both the index of disagreement and the variance of the observed values (when EF increases toward 1, the fit increases); and the coefficient of residual mass (CRM) which is a measure of the tendency of the equation to overestimate or underestimate the observed values (a negative CRM indicates a tendency of the model toward overestimation).

For data set (iii), a one-way analysis of variance (ANOVA) was performed to determine whether the numbers of outbreaks predicted by the model in each category of loquat scab severity defined by the expert (i.e., low, medium, or high) were significantly different from one another.

Results of model validation

Predicted vs. observed disease incidence in orchards. In 2011 between 1 January (fruit set) and 23 May (harvest), 257.6 mm of rain fell, distributed in three main periods: the last week of January, the second week of March (with 64.8 mm of rain in 1 day), and the last 2 weeks of April (with daily temperature $>15^{\circ}\text{C}$) (Fig. 6.5 A). According to the model, a total of 33 infection periods were triggered by these rain events, and the first was on 17 January (Fig. 6.5 B and 6.5 C). In the analysis of this model output, infection periods were clustered in “infection clusters” based on an interval of a minimum of 5 days elapsed between the beginning of two consecutive infection clusters (i.e., the protection provided by a copper-based fungicide application as described in González-Domínguez *et al.*, 2014c); therefore, there were 10 infection clusters in the considered period. $\Sigma LULI$ began to increase from mid-January to mid-February (with three infection clusters), but three infection clusters in March resulted in a substantial increase in $\Sigma LULI$ to 0.5; March had 12 infections periods, and the repeated and abundant rain events provided >18 h of wetness on most days (Fig. 6.5). From mid-April to the end of the considered period, a constant increase in $\Sigma LULI$ was associated with abundant rain events and increasing temperature, which triggered four infection clusters (Fig. 6.5).

In 2012, although the total volume of rain that fell from 15 December to 10 May was similar (255.8 mm) to that in 2011, there were fewer rain events. The model predicted 20 infection periods that were grouped into 12 infection clusters (Fig. 6.6 B and 6.6 C). In 2012, rainy periods were separated by dry periods; from the end of January to mid-March, dry periods caused no substantial infection to develop (Fig 6.6 C). Therefore, there were two main periods of $\Sigma LULI$ increase: the last half of January and from the end of March to May (Fig 6.6 D).

Goodness-of-fit for $\Sigma LULI$ predicted by the model versus loquat scab incidence observed in the field was greater when a fixed period of 21 days was considered than when the latency period was based on DD. In the former case, values of R^2 , CCC, r , Cb, NS, W, and EF were >0.95 (Table 6.2); in the latter case, the values of R^2 and CCC were <0.85 , and values of model efficacy (NS) and model efficiency (EF) were 0.75 (Table 6.2) as a consequence of the high dispersion of residues in 2012 (Fig. 6.7). The model slightly overestimated scab incidence when a latency of 21 days was used (CRM=-0.009) and underestimated scab incidence when DD were used (CRM=0.182) (Table 6.2; Fig. 6.7). For both latency options, the regression equations of predicted versus observed data had slopes and intercepts that were not significantly different from 1 and 0, respectively.

Table 6.2. Statistics and indices used for evaluating the goodness-of-fit of loquat scab infection predicted by the model versus disease observed in field.

Data set ^a	a ^b	b	P(a=0)	P(b=1)	R ²	CCC	r	Cb	NS	W	EF	CRM
Data set 1 (latency=21 days)	0.038	0.939	0.190	0.070	0.952	0.974 (0.946-0.988)	0.975	0.999	0.951	0.987	0.951	-0.009
Data set 1 (latency =420 DD)	-0.066	0.928	0.274	0.110	0.841	0.882 (0.758-0.944)	0.921	0.960	0.753	0.939	0.752	-0.289
Data set 2	0.043	0.965	0.02	0.1	0.984	0.986 (0.942-0.996)	0.993	0.993	0.971	0.992	0.971	-0.247

^aData set 1 corresponds to comparison of daily accumulated LUVI predicted by the model versus observed data of loquat scab incidence in an orchard in southeastern Spain during 2 years (2011 and 2012). The model used a latency period of 21 days (first row) or 420 DD (second row). Data set 2 compares the increase of model output in weeks in which loquat shoots were exposed to splashing rain (triggering infection) with final disease severity in those shoots.

^ba and b, parameters of the regression line of the predicted against observed values; P, probability level for the null hypotheses that a=0 and b=1; R², coefficient of determination of the regression line; CCC, concordance correlation coefficient; r, Pearson product-moment correlation coefficient; Cb, bias estimation factor; NS, model efficacy; W, index of agreement; EF, model efficiency; CRM, coefficient of residual mass.

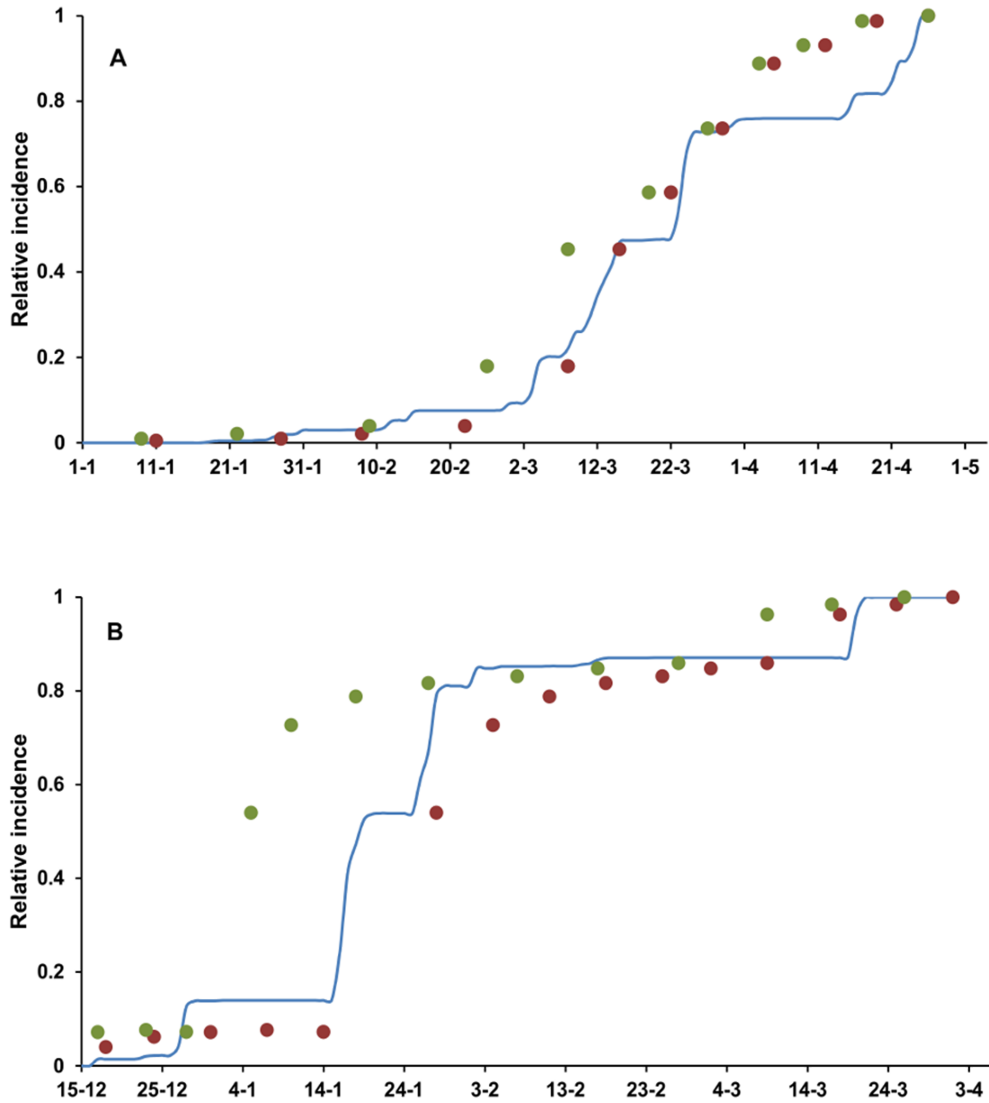

Figure 6.7. Comparison between model output and scab observed on loquat fruit in southeastern Spain. **(A)** data from 2011 and **(B)** data from 2012. Blue lines represent the rescaled infection predicted by the model as the seasonal summation of the lesion units with latent infections ($\Sigma LULI$). Points represent rescaled incidence of loquat fruit with scab observed in the orchards; rescaled incidence is shifted back by 21 days (red points) or 420 DD (base 0°C, green points) to account for the latency period, i.e., the time elapsed between infection and visible symptoms in the form of sporulating scab lesions.

Predicted vs. observed disease incidence in single-exposure experiments. From 4 February to 15 April 2013, the model predicted 15 loquat scab infection periods but disease outbreaks were substantial (i.e., they resulted in a >10% increase in severity) in only two exposure periods. In these two cases, *LULI* values were >0.1; when there were no or light outbreaks, *LULI* values were <0.06 (Fig. 6.8). The goodness-of-fit of predicted versus observed for data set (ii) (Table 6.2) provided values >0.97 for R^2 , CCC, r , Cb, NS, W, and EF. Although the slope was not significantly different from 1, the intercept was different from 0 at $P=0.02$ (Table 6.2). The negative value of CRM indicated that the model somewhat overestimated disease, mainly when observed disease severity was low (Fig. 6.8).

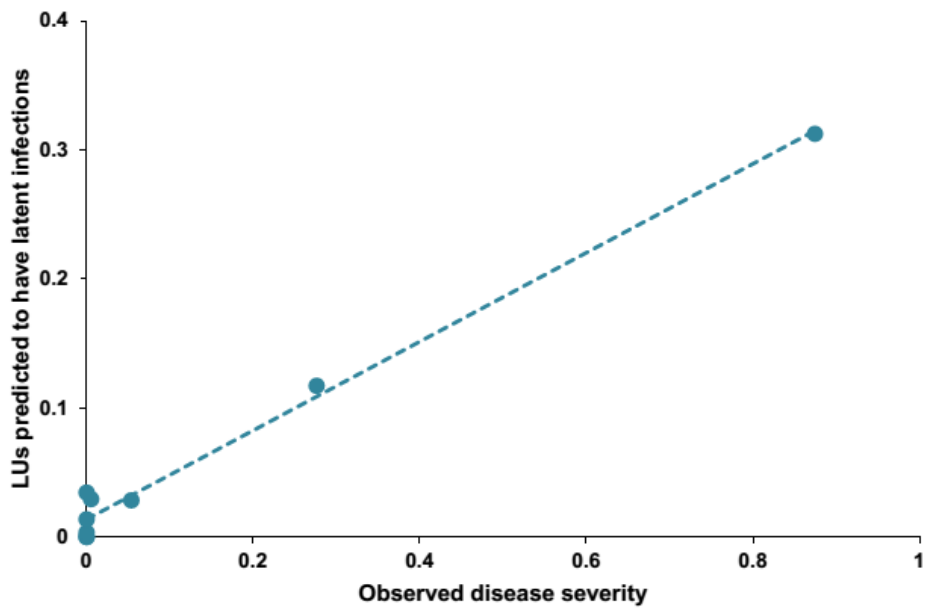

Figure 6.8. Comparison between model output and scab on loquat fruit in single-exposure experiments. Experiments were carried out in a loquat orchard in southeastern Spain in 2013. Observed data (X axis) are expressed as the rescaled disease severity in 11 groups of fruits that were exposed (for 7-day-long moving periods) to splashing rain in a severely affected orchard; model output (Y axis) is expressed as the summation of the lesion units with latent infections ($\Sigma LULI$) in the exposure period.

Expert assessment. The loquat scab epidemics that occurred in the eight seasons of data set (iii) were considered by the expert to be of low, medium, or high severity in two, three, and three seasons, respectively. The number of outbreaks predicted by the model ranged from 4 to 17 among the eight seasons. Although the average number of outbreaks predicted by the model increased as the expert assessment of disease severity increased (Fig. 6.9), the number of predicted epidemics did not significantly differ among the severity categories ($P=0.71$).

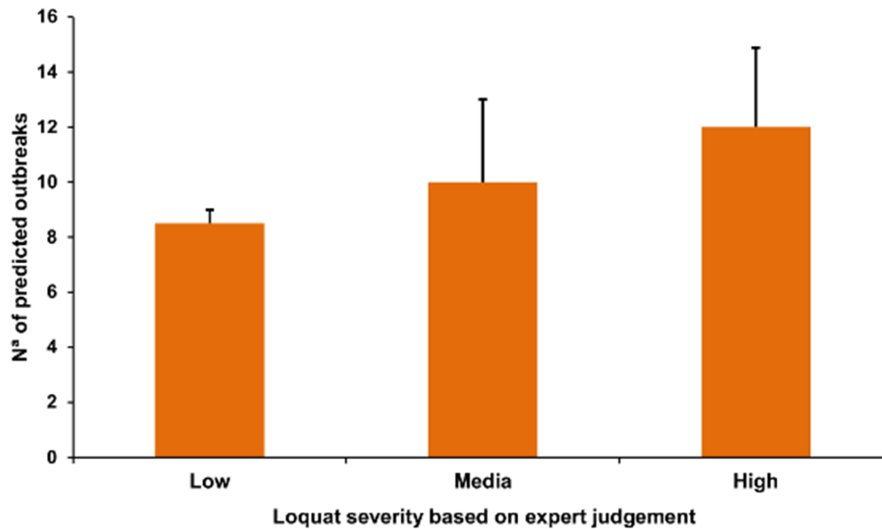

Figure 6.9. Comparison between model output and expert assessment in southeastern Spain from 2006 to 2013. Loquat severity was estimated as low, medium, or high by an expert advisor; bars show the average number (+ SE) of scab outbreaks predicted by the model in each severity category. A disease outbreak was defined as $\Sigma LULI > 0.1$ in 1 day, when no outbreaks were predicted on the previous 5 days.

Discussion

In this work, a dynamic model was developed to predict infection of loquat fruits by conidia of *F. erobotryae*. The model uses a mechanistic approach to describe the infection process (De Wolf and Isard, 2007; Krause and Massie, 1975; Rossi *et al.*, 2010): the model splits the disease cycle of *F. erobotryae* into different state variables, which change from one state to the following state based on rate variables or switches that depend on

environmental conditions by means of mathematical equations. The mathematical equations were developed using published data on *F. erobotryae* conidial dispersion patterns (González-Domínguez *et al.*, 2014d) and on *F. erobotryae* growth, conidial germination, and infection under different environmental conditions (González-Domínguez *et al.*, 2013b; Sánchez-Torres *et al.*, 2009). In the absence of precise information, assumptions were made based on available knowledge.

The model refers the infection process to a lesion unit (LU), which is the surface unit of the fruit which can become occupied by a scab lesion. This approach is related to the concept of “carrying capacity”. In ecology, the carrying capacity is interpreted broadly as the maximum population size that any area of land or water can sustain (Hui, 2006; Townsend *et al.*, 2008). In plant pathology, the host’s carrying capacity for disease is the maximum possible number of lesions that a plant (or an organ) can hold (Zadoks and Schein, 1979). The carrying capacity is a common concept in plant disease modeling (Bennett *et al.*, 2012; Caffi *et al.*, 2009; Ghanbarnia *et al.*, 2009; Gilligan and van den Bosch, 2008).

Model validation showed that the model correctly predicted the occurrence of infection periods and the severity of any infection period, as demonstrated by the goodness-of-fit for the data collected on fruits exposed to single rainy periods. Because the purpose of the model is to be part of a warning system for loquat scab management, the ability to correctly predict infection periods is crucial. Accuracy of the model was also confirmed by the comparison of model output with expert assessment. Even though the numbers of predicted outbreaks did not differ among seasons that the expert had categorized as having low, medium, or high disease severity, the number of predicted outbreaks increased with increases in assessed disease severity.

For model validation, the latency period required for the appearance of scab was expressed as a fixed number of days or of degree-days (DD) based on results from Sánchez-Torres *et al.* (2009). Goodness-of-fit of model prediction was overall better using a fixed period of 21 days instead of 420 DD. In particular, the model underestimated the disease in the early season of 2012 when DD were used. The underestimation was probably caused by low temperatures in that period, which delayed DD accumulation. This result is questionable, because the physiological development of fungi is usually more closely related to DD than to calendar days (Fourie *et al.*, 2013; Gadoury and MacHardy, 1982). In this work, DD was fixed based on the latency period observed in loquat plants kept at the optimal temperature for *F. erobotryae* development, i.e., 21 days at 20°C (Sánchez-Torres *et al.*, 2009). Therefore, the DD value used in this study did not account for the non-linear response of

F. eriobotryae growth to temperatures between 5 and 30°C (González-Domínguez *et al.*, 2013b). If a function for predicting the appearance of scab symptoms is needed in the model, such a function should be temperature dependent, as it is in models for *V. nashicola* (Li *et al.*, 2007) and *F. oleagineum* (Roubal *et al.*, 2013). Salerno *et al.* (1971a) repeatedly exposed potted loquat plants under the canopies of affected trees for 3 days and then incubated these plants under a roof until the appearance of symptoms. Scab appeared in 11 to 26 days at temperatures ranging from 11.4 to 17°C (with a DD range of 157 to 340) and after >220 days at temperatures >20°C. Ptskialadze (1968) found scab symptoms on both leaves and fruits 34 and 16 days after infection at 1-4°C and 21-25°C, respectively. Even though the calculation of latency can be improved, the model error in predicting disease onset due to a fix latency period may not reduce the ability of the model to correctly predict infection periods or reduce the value of the model for timing fungicides applications.

The model capitalized on recent research concerning loquat scab (González-Domínguez *et al.*, 2013b; Sánchez-Torres *et al.*, 2009; González-Domínguez *et al.*, 2014d). These studies have considered most of the components of the disease cycle, including dispersion of conidia, infection, incubation, and latency. Nevertheless, other components should be elucidated to improve our knowledge and thus to improve the model (De Wolf and Isard, 2007). Currently, the model assumes that inoculum sources are always present in scab-affected loquat orchards and that viable *F. eriobotryae* inoculum is always present at fruit set (i.e., when the model begins operating) and beyond. Salerno *et al.* (1971a) found that lesions appear in autumn on leaves that were infected the previous spring, and Prota (1960) found that the lesions appearing in autumn produce conidia for 5 to 6 months and that those viable conidia are present all year long. These observations were carried out in Sicily and Sardinia, respectively (i.e., under a Mediterranean climate); therefore, the model assumptions seem plausible. The assumptions that inoculum sources and viable conidia are always present in scab-affected loquat orchards are both precautionary because they can lead to over prediction of infection (which would occur if weather conditions were suitable for infection but no viable conidia were available) and thus to unnecessary applications of fungicides or other disease management measures. Because unnecessary fungicide applications entail costs for growers, consumers, and the environment (Shtienberg, 2013), the model should be expanded to include the oversummering and availability of conidia.

With respect to overwintering, modeling the dormant stage of fungal pathogens is challenging (De Wolf and Isard, 2007), and the dormant stage has therefore been included in only a few models (Holtslag *et al.*, 2004; Legler *et al.*, 2013; Luo and Michailides, 2001; Rossi *et al.*, 2005). For this purpose, two key aspects must be addressed: (i) the inoculum dose (i.e., the quantity of inoculum that overwinters), which depends on the severity of the disease in each orchard at the end of the previous season; and (ii) the time when the primary inoculum begins to be available for infection. In other models, the inoculum dose was directly measured in the field (Holtslag *et al.*, 2004; Gadoury and MacHardy, 1986) or broadly estimated as low/high disease pressure (Luo and Michailides, 2001). In our case, incorporation into the model of the specific farmer's assessment of the disease severity in the previous season may represent useful information regarding the potential primary inoculum dose. Modeling the sporulation patterns of *F. eriobotryae* may make it possible to estimate the available inoculum at each infection period. This estimation may consequently improve the ability of the model to predict the severity of each infection period. To account for the presence of inoculum in a model for *V. inaequalis*, Xu *et al.* (1995) assumed a minimum interval of 7 hours between two successive infection processes to allow lesions to recover and sporulate, even though this approximation could introduce errors, because sporulation is highly dependent on temperature and RH (MacHardy, 1996).

Even without the above possible improvements, the present model can contribute to the practical control of loquat scab. The underutilization of disease predictive systems by farmers has been broadly discussed (Gent *et al.*, 2011; 2013; Rossi *et al.*, 2012; Schut *et al.*, 2014; Shtienberg, 2013). Rossi *et al.* (2012) summarized the steps necessary for the practical implementation of a model as: (i) develop a computerized version of the model; (ii) create a network of agro-meteorological stations for collecting weather data; (iii) design a strategy for decision-making based on the model output; (iv) develop tools for supporting decision-making (e.g., decision support systems or disease warning systems); and (v) build user's confidence in the model by demonstrating the advantages of its use in comparison with the current options. Efforts devoted to the last three steps are crucial for the future applicability of the model (Rossi *et al.*, 2010) and requires a deep knowledge of the cultural context in which the model will be delivered, the farmers' perception of risk, and the current management of the disease (Gent *et al.*, 2013).

In the main loquat cultivation areas of Spain, the regional plant protection services use the Mills-Laplante tables (Mills and Laplante, 1954),

which were developed to control apple scab, to estimate the risk of infection by *F. eriobotryae* (GVA, 2013). Researchers have indicated that the Mills-Laplante tables over-predict the number of infections for apple scab (Li *et al.*, 2007; MacHardy and Gadoury, 1989). That the tables could over-predict the number of loquat scab infections has also been discussed, because the conidia of *F. eriobotryae* require longer times for leaf infection than those described by the Mills-Laplante tables for *V. inaequalis* and because the temperature range in which *F. eriobotryae* infection occurs is quite different (González-Domínguez *et al.*, 2013b, 2014d). Thus, the present model represent an improvement in loquat scab management, i.e., it should optimise scab management by helping loquat growers to schedule and probably to reduce fungicide applications.

The long-term existence of a warning system for loquat scab monitoring in Spain (González-Domínguez *et al.*, 2013a) may facilitate the implementation of the model developed in this area because i) extension agents and advisors are familiar with the use and interpretation of epidemiological models, and ii) loquat farmers are accustomed to considering the concept of “infection risk” when scheduling fungicide applications.

Because model building is “a never-ending story” (Teng, 1981; Gent *et al.*, 2013), researchers will likely continue to improve the loquat scab model described here. As discussed in this manuscript, it will be necessary to define a relationship between model output and infection severity so as to identify appropriate thresholds for deciding when the treatments are needed (Rossi *et al.*, 2010; Madden *et al.*, 2007).

Acknowledgements

We would like to thank E. Soler his technical assistance and his contribution for model validation.

Chapter 7

A nested-polymerase chain reaction protocol for *in planta* detection of *Fusicladium eriobotryae*, causal agent of loquat scab.

Elisa González-Domínguez, Maela León, Josep Armengol, and Mónica Berbegal. (2014). Journal of Phytopathology. Accepted.
Instituto Agroforestal Mediterráneo, Universidad Politécnica de Valencia, Camino de Vera s/n, 46022-Valencia, Spain.

Abstract

Scab caused by the fungus *Fusicladium eriobotryae* is the most serious disease affecting loquat in Spain. Isolation of *F. eriobotryae* from infected tissue on culture media can be difficult due to its slow growth. A polymerase chain reaction (PCR) based protocol was developed for *F. eriobotryae*-specific identification from pure culture or infected loquat tissues. The primer set was designed in the elongation factor 1- α gene (EF1- α), and specificity and sensitivity for single and nested-PCR were validated. The nested-PCR assay resulted in 100% positive detection of *F. eriobotryae* in naturally and artificially infected tissues. This protocol can be useful for routine diagnosis, disease monitoring programs and epidemiological research.

Introduction

Loquat (*Eriobotrya japonica* (Thunb) Lindl.) is a fruit tree grown in regions with subtropical climate including China, Japan and the Mediterranean basin (Lin, 2007). Loquat scab, caused by the fungus *Fusicladium eriobotryae* (Cavara) Sacc., is the most serious disease affecting this crop in Spain (Sánchez-Torres *et al.*, 2009; Gladieux *et al.*, 2010). *Fusicladium eriobotryae* infects young twigs, leaves and fruits, causing olive-brown spots and resulting in significant economic losses (Sánchez-Torres *et al.*, 2009). *Fusicladium* spp. are the anamorphic stages of the ascomycete genus *Venturia*, which include well-known plant pathogens such as *V. inaequalis* on apple, *V. pyrina* on pear, and *F. oleagineum* on olive (Schubert *et al.*, 2003).

Isolation of *F. eriobotryae* from infected tissue on culture media is difficult due to its slow growth, making the process prone to contaminations by other fungal species (Sánchez-Torres *et al.*, 2009). In addition, morphological characteristics of *F. eriobotryae* conidia are similar to those of other Venturiaceae, such as *V. inaequalis* or *V. pyrina* (Schubert *et al.*, 2003). Although

host specificity of these three species confirms its identity through direct isolation from affected tissues, in some cases its identification can be uncertain; for example, in conidial captures from air or rain samples. Moreover, in the past several authors considered *F. eriobotryae* and *V. inaequalis* as synonymous (Schubert *et al.*, 2003), thus cultures in collections or herbariums could have been misidentified. For these reasons, alternative methods to classical identification must be developed.

PCR has become a valuable tool for the detection and diagnose of plant-pathogenic fungi. PCR-based protocols provide several advantages over traditional detection methods because of its specificity, sensitivity and fastness. To date, specific primers have been developed for the identification of *F. oleagineum* (González-Lamothe *et al.*, 2002), *V. inaequalis* and *V. pyrina* (Stehmann *et al.*, 2001), but not for *F. eriobotryae*.

For primer design purpose, nuclear ribosomal internal transcribed spacer regions (ITS1 and ITS2) have been commonly used (White *et al.* 1990). However, Gladioux *et al.* (2010) analyzed the divergence among several *Venturia* species, including *F. eriobotryae*, at six nuclear loci, showing that the highest variation occurred in partial sequences of EF1- α gene. Thus, in this research, variations among *Venturia* spp. at the ITS region and EF1- α gene are explored for a *F. eriobotryae*-specific primer pair design. The specific objectives of the study were to: (i) develop a PCR-based protocol for the identification of *F. eriobotryae*, and (ii) test this protocol for the *in planta* detection of *F. eriobotryae*.

Material and methods

A total of 39 isolates were used in this study (Table 7.1). For all species except *F. oleagineum*, pure cultures were stored in 15% glycerol solution at -80°C in 1.5 ml cryovials. For *F. oleagineum*, DNA was directly extracted from lesions in leaves due to the difficulties in its isolation. DNA from all isolates was extracted using the E.Z.N.A. Plant Miniprep kit (Omega Bio-Tek, Norcross, GA) and quantified using a spectrophotometer (ND-1000, NanoDrop Technologies, Wilmington, DE).

A subset of isolates of *F. eriobotryae*, *V. inaequalis* and *V. pyrina* (Table 7.1) was selected for primer design because of its high genetic similarity (Gladioux *et al.*, 2010). For *F. eriobotryae* and *V. inaequalis* isolates were representative of different locations. Sequences from the ITS region and EF1- α gene were obtained using the universal primer pairs ITS1F/ITS4 and EF1-688F/EF1-1251R, respectively (Gardes and Bruns, 1993; White *et al.*, 1990; Alves *et al.*, 2008).

Table 7.1. List of *Fusicladium eriobotryae* isolates and other fungi used to determine specificity of the species-specific primer.

Fungal species	Source ^a	Host	Location	Collection code	GenBank ^b	Year	
<i>Fusicladium eriobotryae</i>	IAM	<i>Eriobotrya japonica</i>	Valencia, Spain	FE-6		2008	
	IAM	<i>E. japonica</i>	Valencia, Spain	FE-52 ^c	KJ747037	2011	
	IAM	<i>E. japonica</i>	Granada, Spain	FE-59		2011	
	IAM	<i>E. japonica</i>	Granada, Spain	FE-65 ^c	KJ747038	2011	
	IAM	<i>E. japonica</i>	Castellón, Spain	FE-106		2011	
	IAM	<i>E. japonica</i>	Castellón, Spain	FE-107 ^c		2011	
	IAM	<i>E. japonica</i>	Valencia, Spain	FE-112 ^c		2011	
	IAM	<i>E. japonica</i>	Alicante, Spain	FE-118 ^c		2011	
	IAM	<i>E. japonica</i>	Valencia, Spain	FE-119	KJ747039	2011	
	IAM	<i>E. japonica</i>	Castellón, Spain	FE-124 ^c		2011	
	IAM	<i>E. japonica</i>	Castellón, Spain	FE-129 ^b		2011	
	IAM	<i>E. japonica</i>	Castellón, Spain	FE-131		2011	
	IAM	<i>E. japonica</i>	Castellón, Spain	FE-132 ^c		2011	
	IAM	<i>E. japonica</i>	Alicante, Spain	FE-137 ^c		2011	
	IAM	<i>E. japonica</i>	Alicante, Spain	FE-138		2011	
	IAM	<i>E. japonica</i>	Alicante, Spain	FE-142 ^c		2011	
	IAM	<i>E. japonica</i>	Alicante, Spain	FE-257 ^c		2011	
	IAM	<i>E. japonica</i>	Alicante, Spain	FE-270 ^c		2011	
	<i>Venturia inaequalis</i>	UNIRC	<i>E. japonica</i>	Sicily, Italy	FE-272		2013
		UNIRC	<i>E. japonica</i>	Sicily, Italy	FE-273		2013
UNIRC		<i>E. japonica</i>	Sicily, Italy	FE-275		2013	
CBS		<i>Malus domestica</i>	Spain	CBS 121.310 ^c	KJ747040	-	
CBS		<i>Malus sylvestris</i>	The Netherlands	CBS 595.70 ^c	KJ747041	1970	
CBS		<i>M. sylvestris</i>	The Netherlands	CBS 330.65 ^c	KJ747042	1965	
CBS		<i>M. sylvestris</i>	The Netherlands	CBS 815.69 ^c	KJ747043	1965	
PSU		<i>M. domestica</i>	USA	VI-6		2005	
PSU		<i>M. domestica</i>	USA	VI-9		2005	
PSU	<i>M. domestica</i>	USA	VI-12		2005		

Table 7.1. Continued

Fungal species	Source ^a	Host	Location	Collection code	GenBank ^b	Year
<i>V. inaequalis</i>	PSU	<i>M. domestica</i>	USA	VI-19		2005
<i>Venturia pyrina</i>	CBS	<i>Pyrus communis</i>	-	CBS 331.65 ^c	KJ747044	1965
<i>Fusicladium oleagineum</i>	UCO	<i>Olea europaea</i>	Tarragona, Spain	FO-53	KJ747045	2012
	UCO	<i>O. europaea</i>	Córdoba, Spain	FO-131		2012
<i>Aspergillus sp.</i>	IAM	<i>E. japonica</i>	Valencia, Spain	ASP		2008
<i>Cladosporium sp.</i>	IAM	<i>E. japonica</i>	Valencia, Spain	CLA		2008
<i>Alternaria sp.</i>	IAM	<i>E. japonica</i>	Valencia, Spain	ALT-1		2008
<i>Phomopsis sp.</i>	IAM	<i>E. japonica</i>	Valencia, Spain	PHO-1		2008
<i>Mycosphaerella sp.</i>	IAM	<i>E. japonica</i>	Valencia, Spain	MHY		2008
<i>Phyllosticta sp.</i>	IAM	<i>E. japonica</i>	Valencia, Spain	PHYL		2008
<i>Stemphylium sp.</i>	IAM	<i>E. japonica</i>	Valencia, Spain	STEM		2008
<i>Pestalotiopsis sp.</i>	IAM	<i>E. japonica</i>	Valencia, Spain	PEST		2008
<i>Penicillium sp.</i>	IAM	<i>E. japonica</i>	Valencia, Spain	PENI		2008

^a Isolates were obtained from: CBS, Centraalbureau voor Schimmelcultures, Utrecht, the Netherlands; IAM, Culture Collection of the Instituto Agroforestal Mediterráneo; PSU, Dr. M^a del Mar Jiménez-Gasco, Department of Plant Pathology, Pennsylvania State University, PA, USA; UCO, Dr. Juan Moral, Departamento de Agronomía, ETSIAM, Córdoba, Spain; UNIRC, Dr. Gaetano Magnano di San Lio, Department of Agricultural Science, Mediterranean University of Reggio Calabria, Sicily, Italy.

^b GenBank accession number of sequences generated for primer design.

^c Isolates used to determine specificity and sensitivity of the nested-PCR protocol.

- No information available.

Each PCR reaction mix (final volume of 25 µl) contained 1x PCR buffer, 2.5 mM MgCl₂, 200 µM of each dNTP, 1 µM of each primer, 1 U of Netzyme DNA polymerase (Dominion MBL, Córdoba, Spain) and 1 µl of template DNA. Amplifications were performed on a Peltier Thermal Cycler-200 (MJ Research, Waltham, MA). The program consisted of an initial step of 3 min at 94°C, 35 cycles consisting of 30 s at 94°C, 30 s at 55°C, and 45 s at 72°C and a final of 10 min extension at 72°C. The resulting products were sequenced at Macrogen (Amsterdam, The Netherlands). The sequences obtained were edited and aligned using MEGA5 software (Tamura *et al.*, 2011). No substantial differences were observed when the sequences of the ITS region obtained for *F. eriobotryae* and *V. inaequalis* were compared. Thus, potential species-specific primers were designed on the basis of divergence observed in the EF1-α gen. The characteristics of the primers were evaluated with DNAMAN (Lynnon BioSoft, Montreal, Canada) and the primers were synthesized by Macrogen.

Specificity of the primers were tested on DNA from all isolates of Table 7.1. The PCR reaction mix was the same as described before, and the PCR profile included initial denaturing for 3 min at 94°C, 30 cycles consisting of 30 s at 94°C, 30 s at 60°C, and 1 min at 72°C and a final of 10 min extension at 72°C. PCR products were separated on a 1.5% agarose gel and visualized under UV light. Specificity of a nested-PCR protocol was assessed using the *Venturia* spp. isolates included in the Table 7.1. The universal primers EF1-688F/EF1-1251R were used in the first round of the nested-PCR amplifications following conditions described before. Diluted PCR products (1:10) were used as DNA template for the second round of the nested-PCR amplification using the specific primer pair and PCR conditions described before. For both, single and nested-PCR all reactions were repeated three times including ultrapure sterile water USW (Chromasolv Plus; Sigma- Aldrich, Steinheim, Germany) as negative control.

Sensitivity of the single and nested-PCR was assessed by amplification of several dilutions (1:10 to 1:10⁶) of DNA from isolate FE-112; fungal DNA was diluted in USW as well as in *E. japonica* DNA obtained from 0.1 g of healthy leaf tissue from a 2-years old tree loquat kept in growing chamber. In all cases DNA were quantified using a spectrophotometer (ND- 1000, NanoDrop Technologies, Wilmington, DE). All PCR reactions were repeated three times using the conditions described above.

To test the protocol for *in planta* detection of *F. eriobotryae* natural and artificially infected fruit and leaf samples (González-Domínguez *et al.*, 2013b) with symptoms of loquat scab were employed (Table 7.2). Each sample was surface sterilized and frozen at -80 °C for 30 min; then, tissue (0.1–0.5 g) was disrupted on a TissueLyser LT (Qiagen, Hilden, Germany) using 2 stainless steel beads, 5 mm diameter (Qiagen). Total DNA was extracted from disrupted tissue with the

E.Z.N.A. Plant Miniprep kit. The single and nested-PCR protocols described previously were tested for amplification of *F. eriobotryae*. Reactions were repeated twice, including *F. eriobotryae* DNA from isolate FE-112 and USW as positive and negative controls, respectively.

Results and Discussion

The ITS region was not useful for primers development to specifically identify *F. eriobotryae*. Previous studies have also demonstrated the high level of similarity in this region between different species of the genus *Venturia* (Gladieux *et al.*, 2010; Sánchez-Torres *et al.*, 2009). A specific primer (Fusic1F: 5'- GCAAATTTTGCACTGGC -3') was designed on the basis of *F. eriobotryae* divergence observed when partial sequences of the EF1- α gen obtained from *Venturia* spp. were compared. Fusic1F combined with universal primer EF1-986R (Carbone and Kohn, 1999) amplified a product of 197 bp for all *F. eriobotryae* isolates tested (Table 7.1). Amplicons were not obtained from samples of *V. inaequalis*, *V. pyrina* and *F. oleagineum* neither from samples of other fungal species commonly found in the process of isolation (Table 7.1). Detection threshold resulted in 3 ng/ μ l of *F. eriobotryae* DNA for single PCR protocol and 3 pg for nested-PCR protocol. Thresholds did not change when fungal DNA was dissolved in water or loquat DNA extract, indicating that no interference with the PCR occurred. Nested-PCR assay using the primer pairs (EF1-688F/EF1-1251R and Fusic1F/EF1-986R) and DNA extracted from lesions in fresh fruits and leaves resulted in 100% positive detection of *F. eriobotryae* in the infected tissues. However, amplification results obtained using the single PCR protocol were erratic and failed to detect some of the infected samples and/or replications of the same sample (Table 7.2). Similar nested-PCR protocols have been recently validated for the identification of other fruit tree pathogens, such as *V. nashicola* (Koh *et al.*, 2013) on pear or *Mycosphaerella nawae* (Berbegal *et al.*, 2013) on persimmon.

A PCR-based protocol has been developed for *F. eriobotryae* specific identification from pure culture or loquat tissues showing scab symptoms. This protocol can be useful for routine diagnosis, disease monitoring programs and for epidemiological studies, all of them essential aspects for the implementation of efficient management strategies for loquat scab.

Acknowledgements

Researches that provided the different isolates are acknowledged. We thank M. Calatayud for technical assistance.

Table 7.2. Detection of *F. eriobotryae* in samples from loquat trees using either single or nested PCR assays.

	Fruit samples						Leaf samples			Inoculated sample ^a	Healthy leaf ^b	Control ^c	
	1	2	3	4	5	6	1	2	3			C-	C=
Single PCR	+/+ ^d	+/-	-/-	-/-	+/+	+/+	-/-	+/+	-/+	-/-	-/-	-/-	-/-
Nested-PCR	+/+	+/+	+/+	+/+	+/+	+/+	+/+	+/+	+/+	+/+	-/-	-/-	-/-

^a Leaf sample from a 2-years old tree loquat inoculated following methodology by González-Domínguez *et al.* (2013b).

^b Healthy leaf from a 2-years old tree loquat kept in growing chamber.

^c Ultrapure sterile water was used as negative control in first (C-) and second (C=) round of amplification using the nested-PCR protocol.

^d Results from two independent tests; + = positive amplification, - = no amplification

Chapter 8

Evaluation of fungicides to control loquat scab caused by *Fusicladium eriobotryae*

Elisa González-Domínguez, José M. Rodríguez-Reina, José García-Jiménez and Josep Armengol (2014). Plant Health Progress. Accepted
Instituto Agroforestal Mediterráneo, Universidad Politécnica de Valencia, Camino de Vera s/n, 46022-Valencia, Spain

Abstract

Loquat scab caused by *Fusicladium eriobotryae* is the main disease affecting this crop. The fungus can infect leaves and fruits, reducing the marketable quality of the latter. The efficacy of 13 fungicides against *F. eriobotryae*, was evaluated *in vitro* by testing their effect on mycelial growth and conidial germination. Boscalid, chlorothalonil, didecyldimethyl ammonium chloride and pyraclostrobin were able to reduce both, conidial germination and mycelial growth of *F. eriobotryae*. Moreover, a growth chamber experiment was conducted to determine the pre- and post-infection activity of five selected fungicides. Difenconazole and pyraclostrobin applications resulted in relative disease severity (RDS) values lower than 5%, even when applied 7 days before or after inoculation. Boscalid and mancozeb showed good pre-infection activity against *F. eriobotryae*, whereas values up to 20% of RDS were obtained with copper oxychloride. Results indicate that the fungicides currently recommended in south-eastern Spain against loquat scab provide an adequate disease control, and new active ingredients could be added to the present management strategies.

Introduction

Loquat (*Eriobotrya japonica* (Thunb) Lindl.), a fruit tree native of China, is mainly cultivated in China, Japan and the Mediterranean basin. Spain is the second largest loquat producer and the main exporter worldwide (Caballero and Fernández 2002; MAGRAMA *et al.*, 2013). Loquat scab, caused by *Fusicladium eriobotryae* (Cavara) Sacc. is the main disease affecting this crop (Sánchez-Torres *et al.*, 2009). *Fusicladium* species are the anamorphic stages of the ascomycete genus *Venturia*, although the sexual stage of *F. eriobotryae* has never been found in nature (Gladioux *et al.*, 2010).

F. eriobotryae can infect leaves as well as fruit, mostly in the early stages of development. Symptoms are generally observed on fruits and both sides of leaves as green to olive-brown spots. Under favourable conditions, these lesions can cover almost all the leaf or fruit surface, reducing its marketable fruit quality (Sánchez-Torres *et al.*, 2007b). Conidia of *F. eriobotryae* require mild temperatures and long wet periods to infect loquat plants, and their viability is substantially reduced by dry periods (González-Domínguez *et al.*, 2013b).

In Spain, the fungicides currently labelled to control loquat scab are the same as those used for managing apple scab caused by *Venturia inaequalis* (Cooke) G. Wint. (MAGRAMA, 2014). The management strategy to control loquat scab recommended by the regional plant health services (GVA, 2013), include a copper-based fungicide treatment in October during flowering, followed by treatments in November and December with sterol biosynthesis inhibitor's (SBI) (cyproconazole, difenoconazole or myclobutanil), combined with dithiocarbamates (mancozeb, maneb or metiram). From January to harvest (April), the same SBI fungicides combined with captan are recommended. Application scheduling is decided based on the Mills-Laplante tables (Mills and Laplante, 1954), which were established for the epidemiology of *V. inaequalis*, and, usually, four to five treatments are applied per year.

Specific studies of the effectiveness of different groups of fungicides to control *F. eriobotryae* have never been conducted. In addition, in the European Union the concern for environmental impact of fungicides has caused an extensive transformation in the Commission registration process (91/414/ECC), resulting in a drastic reduction of permitted active ingredients (EU, 1991). The registry of some of the fungicides recommended currently is going to expire in the next few years, and active ingredients permitted are under revision. For these reasons, the current management strategies to control loquat scab in Spain should be updated. The objectives of this study were (i) to evaluate the *in vitro* efficacy of 13 fungicides against *F. eriobotryae*, and (ii) to determine the pre- and post-infection activity of five of these fungicides.

Laboratory test

Two isolates of *F. eriobotryae* (FE-6 and FE-40), obtained from symptomatic loquat fruits in Alicante province (southeastern Spain) were used. Affected fruits were surface-disinfested, incubated in humid chambers for 5 days, and small fragments taken from the edge of the lesions were plated in potato dextrose agar (Biokar Diagnostics, Beauvais, France) supplemented with 0.5 gL⁻¹ of streptomycin sulphate (Sigma-Aldrich, St Louis, MO) (PDAS). Plates were incubated for 20-25 days at 20°C in the dark and plated with the serial dilution

method to obtain single colonies. Identity of both isolates was confirmed by morphology and comparing partial sequences of the elongation factor 1- α gene (EF 1- α) (Sánchez-Torres *et al.*, 2009).

Commercial formulations of 13 fungicides, representing ten different chemical classes, were tested *in vitro* to evaluate their capability to inhibit both mycelial growth and conidial germination of *F. eriobotryae* (Table 8.1).

For the mycelial growth assay, appropriate volumes of each fungicide were added to potato dextrose agar (PDA; Biokar Diagnostics Beauvais, France) to obtain final concentrations of 100, 10, 1, and 0.1 mg of active ingredient per liter (mg a.i. L⁻¹). Mycelial plugs (8 mm in diameter), were transferred to fungicide-amended petri dishes. There were five replicates of each fungicide concentration and isolate, and the experiment was conducted twice. Control PDA plates were prepared similarly by adding sterile distilled water instead of the fungicide. The dishes were incubated at 25 °C in the dark for 30 days, and the diameter of each colony was measured.

Table 8.1. Fungicides selected for *in vitro* sensitivity testing.

Chemical Group ^a	Active ingredient ^b	Trade name	Manufacturer
Pyridine-carboxamides	Boscalid*	Cantus	BASF
Phthalimides	Captan	Captan 50	IQV
Chloronitrile	Chlorothalonil	Clortalonil 50	Sipcam Inagra
Copper	Copper oxychloride*	Curenox 50	IQV
QA	C ₂₂ H ₄₈ CIN ^c	Sporekill	ICA
Triazole	Difenoconazole*	Score	Syngenta
Hydroxyanilides	Fenhexamid	Teldor	Bayer
Triazole	Flusilazole	Olymp	Du Pont Lérida Unión
Dithiocarbamates	Mancozeb*	Mancozeb 80WP	Química
Methoxy-carbamate	Pyraclostrobin*	Cabrio	BASF
Triazole	Tebuconazole	Folicur	Bayer
MBC	Thiophanate-methyl	Pelt	Bayer
QOI	Trifloxystrobin	Flint	Bayer

^a QA, Quaternary ammonium; MBC, Methyl benzimidazole carbamates; QOI, Quinone outside inhibitors.

^b (*) Fungicides tested in plant experiment.

^c Didecyl-dimethylammonium chloride.

For the conidial germination assay, 50 ml of conidial suspensions (5×10^4 conidia ml^{-1}) were dispersed into 250-ml erlenmeyer flasks and appropriate volumes of each fungicide were added to achieve the final concentration. Conidial suspension without fungicide served as a control. Five 50- μl droplets of suspensions were subsequently placed on microscopic slides and incubated in a moist chamber at 20°C in the dark. Conidial germination was assessed after 48 hours for each combination of fungicide concentration and isolate. Two hundred conidia were assessed for germination in each droplet. A conidium was considered germinated when the germ tube had exceeded the length of the conidium. The experiment was conducted twice.

EC_{50} value was calculated for each isolate and each fungicide. Significance levels for mean EC_{50} values were determined by the Kruskal-Wallis one-way analysis of variance on ranks and mean separation was conducted. Analysis of variance showed that there were no differences in the inhibition of mycelial growth ($P=0.825$) and conidial germination ($P=0.1066$) between the two experimental repeats, so data from the two experiments were combined. Data were analyzed using Statistix 9 (Analytical Software, Tallahassee, FL).

Evaluation of pre- and post-infection activity of selected fungicides

Five fungicides were selected to determine their pre- and post-infection effect against *F. erobotryae* on loquat plants (Table 8.1). Copper oxychloride, difenoconazole and mancozeb are commonly used to control loquat scab in south-eastern Spain, and boscalid and pyraclostrobin were selected because of their good activity *in vitro*. The experiment was conducted on 1-yr-old loquat plants of the cultivar “Algerie”, which is susceptible to loquat scab (Sánchez-Torres *et al.*, 2009). The plants were grown individually in plastic pots (220 cc) and only the youngest four fully expanded leaves were maintained.

The fungicides were applied to the plants 7, 3, 1 or 0 days before the inoculation, or 1, 3, or 7 days post inoculation. Suspensions of the fungicides boscalid (1 g a.i. L^{-1}), copper oxychloride (3.5 g a.i. L^{-1}), difenoconazole (0.15 ml a.i. L^{-1}), mancozeb (2.5 g a.i. L^{-1}) and pyraclostrobin (0.35 ml a.i. L^{-1}) were prepared according to the recommendations to control scab in fruit trees (MAGRAMA, 2014). Fungicides were applied with a pressure sprayer (Bilba; DiMartino spa; Italy) until runoff. For fungal inoculation, a spore suspension of isolate FE-40 (5×10^5 conidia ml^{-1}) was used. A uniform layer of conidial suspension was gently sprayed on leaves using a hand sprayer (W560, Wagner Spraytech Iberica S.A., Spain). Following inoculation, the plants were covered with plastic bags to ensure leaf wetness for 7 days. For fungicide application 1 and 3 days after the inoculation, the plants were treated and covered with the

plastic bags again. The 7-day post-inoculation treatment was applied 30 min before all plants were uncovered. For the day-0 treatment (day of inoculation), sprayed plants were allowed to dry for 1 h prior to inoculation. There were four replicate plants for each treatment. Four control plants were inoculated but were not treated. The experiment was conducted in a growth chamber (20°C; 60% RH; 12h light/12h darkness).

Forty-five days after inoculation disease severity was assessed visually on each plant as the percentage of the leaf area showing typical scab symptoms (González-Domínguez *et al.*, 2013b). The experiment was conducted twice. Relative disease severity (RDS) was calculated as the percentage of disease severity relative to the mean disease severity value in control plants. Analysis of variance was performed to check that there were no differences between the two experimental repeats ($P=0.099$), so data from both experiments were pooled. The Friedman nonparametric two-way analysis of variance was performed to evaluate the effect of fungicide on RDS. Analyses were performed using Statistix 9 (Analytical Software, Tallahassee, FL).

***In vitro* sensitivity of fungicides**

Differences between mycelial growth and conidial germination of *F. erobotryae* were highly significant among fungicides ($P<0.01$ in both cases). However, the effect of isolate was not significant for mycelial growth ($P=0.065$) nor for conidial germination ($P=0.3298$), thus data from the different isolates were pooled.

Mean EC_{50} values for the reduction in mycelial growth and conidial germination of *F. erobotryae* are shown in Table 8.2. Boscalid, chlorothalonil, didecyldimethyl ammonium chloride, difenoconazole, flusilazole, pyraclostrobin, tebuconazole, and thiophanate-methyl were the most effective fungicides in inhibiting mycelial growth with EC_{50} values lower than 1.5 mg a.i. L^{-1} . All other fungicides were less effective in inhibiting mycelial growth, with EC_{50} values ranging from 10.2 to >100 mg a.i. L^{-1} . Boscalid, captan, chlorothalonil, didecyldimethyl ammonium chloride, mancozeb, pyraclostrobin and trifloxystrobin were the most effective fungicides in inhibiting conidial germination, with EC_{50} values lower than 1.2 mg a.i. L^{-1} . Copper oxychloride and thiophanate-methyl had EC_{50} values of 3.97 mg a.i. L^{-1} and 13.54 mg a.i. L^{-1} , respectively, while the rest of the fungicides had EC_{50} values over 50 mg a.i. L^{-1} .

For most of the fungicides evaluated, similar results had been obtained in previous *in vitro* assays with other diseases caused by fungi in the Venturiaceae, such as *Fusicladium oleagineum*, the cause of olive scab (Obanor *et al.*, 2005) or *Venturia inaequalis*, the cause of apple scab (Henríquez *et al.*, 2011). However,

strong differences were observed for thiophanate-methyl; EC₅₀ values for conidial germination of *F. eriobotryae* were higher than those reported for *F. oleagineum*. It is known that thiophanate-methyl acts by inhibiting conidial germination; in this study, EC₅₀ values obtained with this fungicide for conidial germination showed some variability between isolates (data not shown), indicating the possible existence of resistance in *F. eriobotryae*, which is one of the main problems associated with the use of this fungicide (FRAC, 2013). Further research is needed to determine the presence of *F. eriobotryae* isolates resistant to thiophanate-methyl in the main Spanish areas of loquat cultivation.

Table 8.2. EC₅₀ values for inhibiting *in vitro* mycelial growth and conidial germination of *Fusicladium eriobotryae* by fungicides representing different chemical classes.

Fungicide	Mycelial growth ^a		Conidial germination	
Boscalid	1.41	cde ^b	0.33	efg
Captan	71.95	abc	1.24	cde
Chlorothalonil	0.27	def	0.62	def
Copper oxychloride	>100	a	3.97	bcd
Didecyldimethylammonium chloride	0.12	fg	0.24	fg
Difenoconazole	<0.1	g	57.84	abc
Fenhexamid	53.75	abc	89.50	a
Flusilazole	<0.1	g	80.29	a
Mancozeb	10.2	bcd	0.64	def
Pyraclostrobin	0.16	fg	0.11	g
Tebuconazole	0.41	efg	55.86	ab
Thiophanate-methyl	0.51	fg	13.54	abc
Trifloxystrobin	81.84	ab	<0.1	g

^a EC₅₀ values (mg L⁻¹).

^b Values followed by different letters in the column are significantly different according to Kruskal-Wallis one-way analysis of variance of ranks

Pre- and post-infection efficacy of selected fungicides

The effect of the five selected fungicides to control loquat scab was highly significant ($P = 0.0002$). Difenoconazole and pyraclostrobin were effective at all the times of application evaluated, with percentages of RDS always lower than 5% (Fig. 8.1). Boscalid and mancozeb resulted in low values of RDS when they were applied before the inoculation (under 12.24 of RDS for boscalid and 2.70% for mancozeb) and 1 day after (2.70 and 0.42% of RDS, respectively).

However, when these two fungicides were applied 3 or 7 days after the inoculation, the RDS reached values of 32.24 and 27.60%, respectively, for boscalid, and 17.47 and 37.30%, respectively, for mancozeb. The values of RDS obtained in the plants treated with copper oxychloride varied between 5.57 and 29.45%, when this fungicide was applied before the inoculation or 1 day after. However, in the treatments made 3 or 7 days after inoculation, this fungicide reached RDS values of 47 and 98.89%, respectively (Fig. 8.1).

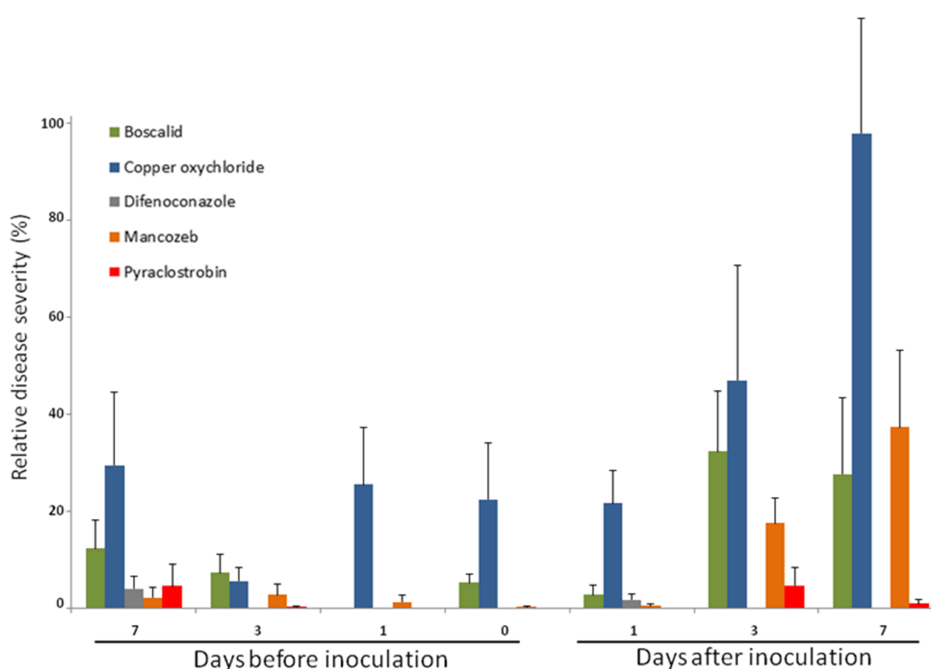

Figure 8.1. Relative severity on loquat plants inoculated with *Fusicladium eriobotryae* and treated with five different fungicides at different times of application. Relative disease severity was calculated as the percentage of severity relative to the median value of severity on control plants. For each combination of fungicide and time of application eight plants were inoculated. Bars represent the standard error.

In previous studies conducted with *V. inaequalis* (Dahmen and Staub, 1992) and *F. oleagineum* (Obanor *et al.*, 2008a), difenoconazole showed good pre-infection efficacy, whereas when this fungicide was applied more than 5 days after inoculation, it did not control the disease. For pyraclostrobin similar results were obtained with other pathogens such as *Phomopsis citri* and *Alternaria alternata* in citrus (Mondal *et al.*, 2007). Obanor *et al.* (2008a) reported a certain

post-infection activity of boscalid against *F. oleagineum*, with no significant differences between applications made 3 days before or 3 days after the inoculation. For mancozeb, our results agreed with those obtained by Schwabe *et al.* (1984) against *V. inaequalis*, where no disease symptoms appeared with application of the fungicide up to 7 days before the inoculation. Copper oxychloride showed a better pre-infection than post-infection activity against *F. erobotryae*. These results are in agreement with the common concept that copper and mancozeb are multi-site protectant-only fungicides (Hewitt, 1998).

Implications in loquat scab control

Our results demonstrate that the fungicides currently recommended in south-eastern Spain against loquat scab are effective against *F. erobotryae* under experimental conditions. Moreover, the introduction of new active ingredients such as pyraclostrobin and boscalid into the current management strategies should be considered. This would facilitate rotations among fungicides with different modes of action, which is one of the main recommended strategies to avoid resistance development (Brent and Hollomon, 2007b).

Although the experiments conducted in this paper provide valuable information on the efficacy of fungicides under controlled growth chamber conditions, optimal treatment schedules and effective dosages for practical use must be evaluated under field conditions. Field trials with boscalid, pyraclostrobin and mancozeb have been effective for managing aerial fungal pathogens of other Mediterranean crops, such as *Mychosphaerella nawae*, the cause of circular leaf spot on persimmon (Berbegal *et al.*, 2011) or *Fusicladium carpophilum* the cause of almond scab (Horsfield *et al.*, 2010).

Currently, the development of an epidemiological model for loquat scab is in progress. This model will allow the implementation of a warning system (González-Domínguez *et al.*, 2013b). Further studies combining the warning system model and the most effective fungicides identified in this study under field conditions could help farmers to schedule spray treatments.

Acknowledgements

This work was funded by Cooperativa Agrícola de Callosa d'En Sarrià (Alicante, Spain).

Chapter 9

Chapter 9

Identification of resistance to difenoconazole and thiophanate-methyl in field populations of *Fusicladium eriobotryae*, and molecular characterization of thiophanate-methyl resistant isolates

Elisa González-Domínguez, Maela León, Josep Armengol and Mónica Berbegal.
Instituto Agroforestal Mediterráneo, Universidad Politécnica de Valencia, Camino de Vera s/n, 46022-Valencia, Spain.

Abstract

Site-specific fungicides of the groups DeMethylation Inhibitors (DMI) and Methyl Benzimidazole Carbamates (MBC) are commonly used to control loquat scab caused by *Fusicladium eriobotryae* in the main loquat producing areas of Spain. In these areas, in seasons with favorable environmental conditions for disease development 4-5 treatments are performed. To assess fungicide resistance, 249 isolates of *F. eriobotryae* were collected from 46 orchards located in the main loquat production provinces of Spain (Alicante, Almería, Castellón, Granada and Valencia). Sensitivity to difenoconazole (DMI) and thiophanate-methyl (MBC) was determined by inhibition of mycelial growth on fungicide-amended media. Resistance to difenoconazole was present in 24 isolates of *F. eriobotryae* (9.6% from the total) in orchards located in all the provinces surveyed, except Almería. Resistance to thiophanate-methyl was present in 26 isolates (10.4%), all from Alicante province. In this province, almost a 15% of the isolates were resistant to this fungicide and *F. eriobotryae* isolates with difenoconazole/thiophanate-methyl multiple resistance were also identified. Molecular characterization of isolates resistant to thiophanate-methyl was performed by sequencing the MBC-target encoding the β -tubulin gene. All *F. eriobotryae* isolates resistant to thiophanate-methyl contained one of the aminoacid substitutions E198K, F200Y or L240F.

Introduction

Loquat scab caused by *Fusicladium eriobotryae* (Cavara) Sacc. is the main disease affecting this crop in Spain. This fungal pathogen infects leaves, shoots, and fruit, causing olive-brown spots which mainly compromise the marketability of the fruit (Sánchez-Torres *et al.*, 2009). *Fusicladium* spp. are the anamorphic stages of the genera *Venturia*, which include other important scab pathogens, such as *V. inaequalis* on apple, *V. pyrina* on pear or *F. oleagineum* on

olive (Schubert *et al.*, 2003). Loquat scab management in Spain has been based on the use of active ingredients proved to be effective against *V. inaequalis*, due to the lack of specific information about fungicide sensitivity of *F. erobotryae* (GVA, 2013; MAGRAMA, 2014). Very recently, a research has been conducted to evaluate the efficacy of different fungicides against loquat scab (González-Domínguez *et al.*, 2014c).

Site-specific fungicides of the groups DeMethylation Inhibitors (DMI; cyproconazole, difenoconazole and myclobutanil) and Methyl Benzimidazole Carbamates (MBC; thiophanate-methyl) are commonly used in Spain. In Alicante province, which accounts for 60% of the total Spanish production (MAGRAMA, 2013), the plant health service integrates the Mills-Laplante tables (Mills and Laplante, 1954) into a warning system to schedule fungicides applications against *F. erobotryae* (GVA, 2013). However, in other Spanish production areas, farmers use to follow a calendar-based spray program. In both cases, in years with favorable environmental conditions for disease development, 4 to 5 treatments per season are applied.

The frequent use of site-specific fungicides has the potential for fungicide resistance development in plant pathogens populations (Brent and Hollomon, 2007a). Cases of resistance to DMI and MBC fungicides have been documented for a large number of fungal plant pathogens (Ma and Michailides, 2005). After the introduction of the first MBC fungicides in the market in the early 1970's, resistance arose very quickly in the same decade (Russell, 2004). Since that, resistance to MBCs has been reported in more than 100 species of plant pathogenic fungi, and specifically for thiophanate-methyl, in several fruit tree pathogens including *V. inaequalis* (Chapman *et al.*, 2011; Quello *et al.*, 2010) and *Monilinia fructicola* (Chen *et al.*, 2013a; Chen *et al.*, 2013b; Mio *et al.*, 2011). MBC resistance has been correlated with point mutations in the β -tubulin gene, which result in altered aminoacid sequences at the benzimidazole-binding site; specifically, changes at codon 6, 50, 167, 198, 200, and 240 in the β -tubulin gene have been reported to cause resistance in field isolates of plant pathogenic fungi (Ma and Michailides, 2005).

DMIs were first used in the 1970s and practical resistance did in fact develop in several fungal pathogens during the 1980s (e.g. powdery mildews, *V. inaequalis*, *Mycosphaerella fijiensis* var. *difformis*), but relatively slowly and with fluctuating severity (Brent and Hollomon, 2007a). However, in the last decade, cases of resistance to DMIs, and more specifically to difenoconazole, have been reported for several fungal pathogens, including *V. inaequalis* (Chapman *et al.*, 2011; Henríquez *et al.*, 2011; Pfeufer and Ngugi, 2012).

Although to date no failures in the control of loquat scab have been reported in Spain, the frequent use of DMI and MBC fungicides makes it necessary to evaluate the presence of *F. eriobotryae* resistant isolates. Thus, the objectives of this study were to (i) determine the sensitivity of *F. eriobotryae* isolates from Spain to difenoconazole (DMI) and thiophanate-methyl (MBC) and (ii) characterize at the molecular level the resistance to thiophanate-methyl.

Materials and Methods

Fungal isolates. From 2008 to 2012, 249 isolates of *F. eriobotryae* were collected from symptomatic loquat fruit in 46 orchards located in the main loquat production provinces of Spain: Alicante ($n=176$), Almería ($n=11$), Castellón ($n=17$), Granada ($n=30$) and Valencia ($n=15$). Isolations were made from symptomatic loquat fruits onto potato dextrose agar (PDA) (Biokar-Diagnostics, France) supplemented with streptomycin sulfate (Sigma-Aldrich, St. Louis, MO, USA) at 0.5 mg ml^{-1} . Isolates were single spored by means of the serial dilution method and stored in 15% glycerol solution at -80°C in 1.5-ml cryovials. Prior to use, a small plug of the colonized agar corresponding to each isolate conserved in a cryovial was transferred to PDA and incubated at 20°C in darkness for one month.

Mycelial growth assays. Isolates were tested for sensitivity to difenoconazole (25% active ingredient [a.i.], emulsionable concentrate, Score, Syngenta), and thiophanate-methyl (45% a.i., suspension concentrate, Pelt, Bayer CropScience) with an *in vitro* mycelial growth assay on fungicide-amended and nonamended PDA (Chapman *et al.*, 2011). The concentrations of $0.1 \text{ } \mu\text{g ml}^{-1}$ and $0.5 \text{ } \mu\text{g ml}^{-1}$ for difenoconazole and thiophanate-methyl, respectively, were used as discriminatory dose based on the baseline sensitivity of the related species *V. inaequalis* (Chapman *et al.*, 2011; Pfeufer and Ngugi, 2012). Fungicides were dissolved in water and dispensed into autoclaved PDA. Mycelial plugs, 4 mm in diameter taken from the margin of a 1-month-old culture on PDA, were placed upside down in the center of fungicide-amended and nonamended PDA plates. Three replications of each isolate and fungicide were prepared, and three replications of non-amended PDA plates were used as control. Plates were incubated at 20°C for 30 days in the dark prior to assessment. Mean radial growth was determined by two perpendicular measurements of the colony diameter. The percent relative growth (RG) was calculated as the ratio between the colony diameter on fungicide-amended medium and nonamended medium.

Isolates were considered difenoconazole-resistant or thiophanate-methyl resistant when growth was inhibited less than 50% (Russell, 2004).

Molecular characterization of thiophanate-methyl resistant isolates. Ten isolates previously classified as resistant and 23 sensitive to thiophanate-methyl, were selected for molecular characterization (Table 9.1). DNA was extracted from *F. eriobotryae* mycelium using the E.Z.N.A. Plant Miniprep kit (Omega Bio-Tek, Norcross, GA) according to the manufacturer's recommendations. Different primers sets were tested, in order to amplify the maximum length of the gene region encoding the β -tubulin: bt1a/bt1b, bt2a/bt2b, bt2a/bt1b, T1/T22 and BtubF14/BtubR (Table 9.2 and Fig. 9.1). For all combinations, PCR reaction mix (final volume of 25 μ l) contained 1x PCR buffer, 2.5 mM MgCl₂, 200 μ M of each dNTP, 1 μ M of each primer, 1 U of Netzyme DNA polymerase (Dominion MBL, Córdoba, Spain) and 1 μ l of template DNA. Amplifications were performed on a Peltier Thermal Cycler-200 (MJ Research, Waltham, MA). The program consisted of an initial step of 3 min at 94°C, 35 cycles consisting of 30 s at 94°C, 30 s at 55°C, and 40 s at 72°C and a final step of 10 min extension at 72°C. The resulting products were sequenced at Macrogen (Amsterdam, The Netherlands). The sequences obtained were edited and aligned using MEGA5 software (Tamura, 2011). A previously published β -tubulin coding sequence (GenBank accession No. M97951.1) of a *V. inaequalis* isolate that was previously characterized as sensitive to thiophanate-methyl was used as a reference (Koenraadt *et al.*, 1992).

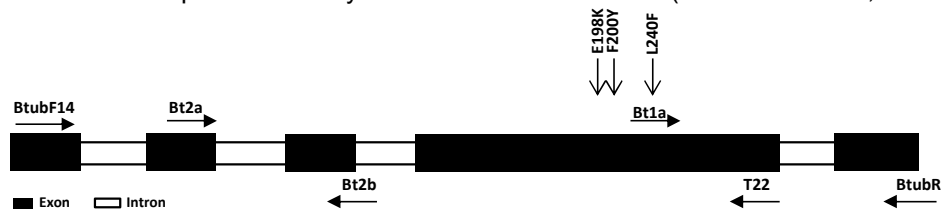

Figure 9.1. Schematic representation of the β -tubulin gene showing the binding sites of the primers used in this study and the point mutations associated to thiophanate-methyl resistance. Black boxes denote protein-coding sequences (exons), and white boxes denote introns.

Table 9.1. Characteristics of *Fusicladium eriobotryae* isolates selected for molecular characterization of thiophanate-methyl resistance.

Isolate	Origin	Year	In vitro assay		Aminoacid substitution		
			RG ^a	Class ^b	E198K ^c	F200Y ^d	L240F ^e
FE-15	Alicante	2008	9.09	S	-	-	-
FE-44	Alicante	2009	0	S	-	-	-
FE-52	Valencia	2011	4.12	S	-	-	-
FE-53	Valencia	2010	0	S	-	-	-
FE-59	Granada	2011	0	S	-	-	-
FE-65	Granada	2011	0	S	-	-	-
FE-66	Granada	2011	0	S	-	-	-
FE-106	Castellón	2011	0	S	-	-	-
FE-107	Castellón	2011	0	S	-	-	-
FE-112	Valencia	2011	1.43	S	-	-	-
FE-115	Valencia	2011	0	S	-	-	-
FE-116	Valencia	2011	2.60	S	-	-	-
FE-118	Alicante	2011	8.51	S	-	-	-
FE-119	Valencia	2011	0	S	-	-	-
FE-120	Castellón	2011	5.61	S	-	-	-
FE-124	Castellón	2011	0	S	-	-	-
FE-129	Castellón	2011	5.38	S	-	-	-
FE-131	Castellón	2011	5.26	S	-	-	-
FE-137	Alicante	2011	7.69	S	-	-	-
FE-138	Alicante	2011	9.38	S	-	-	-
FE-142	Alicante	2011	6.67	S	-	-	-
FE-143	Alicante	2011	0	S	-	-	-
FE-146	Alicante	2011	0	S	-	-	-
FE-7	Alicante	2008	100	R	-	-	+
FE-8	Alicante	2008	63.33	R	-	-	+
FE-26	Alicante	2008	59.46	R	-	-	+
FE-28	Alicante	2008	71.88	R	+	-	-
FE-29	Alicante	2008	81.82	R	+	-	-
FE-190	Alicante	2012	100	R	-	-	+
FE-249	Alicante	2012	63.95	R	-	+	-
FE-252	Alicante	2012	65.08	R	-	-	+
FE-265	Alicante	2012	94.12	R	-	-	+
FE-268	Alicante	2012	98.36	R	-	-	+

^a RG=relative growth, ratio between the colony diameter of *F. eriobotryae* on thiophanate-methyl amended medium (0.5 µg ml⁻¹) and nonamended medium after 30 days of incubation.

^b S=sensitive to thiophanate-methyl (RG<50%); R=resistant to thiophanate-methyl (RG>50%).

^c Point mutation in codon 198 resulting in an aminoacid change from glutamic acid (GAG) to lysine (AAG)

^d Point mutation in codon 200 resulting in an aminoacid change from phenylalanine (TTC) to tyrosine (TAC).

^e Point mutation in codon 240 resulting in an aminoacid change from leucine (CCT) to phenylalanine (CCC).

Results

Sensitivity of *F. eriobotryae* isolates to difenoconazole and thiophanate-methyl. Resistance to difenoconazole was present in 24 isolates of *F. eriobotryae* (9.6% from the total), whereas 26 isolates were resistant to thiophanate-methyl (10.4%). Average RG values were 18.6% for difenoconazole and 12.8% for thiophanate-methyl (Fig. 9.2). Seven isolates (2.8%) were resistant to both, difenoconazole and thiophanate-methyl. Regarding the different provinces of Spain surveyed, isolates resistant to difenoconazole were found in Alicante ($n=12$), Castellón ($n=2$), Granada ($n=6$) and Valencia ($n=4$) (Fig. 9.3). For thiophanate-methyl, all resistant isolates were found in Alicante province ($n=26$) (Fig. 9.3). In Almería province, no resistant isolates to difenoconazole or thiophanate-methyl were found (Fig. 9.3).

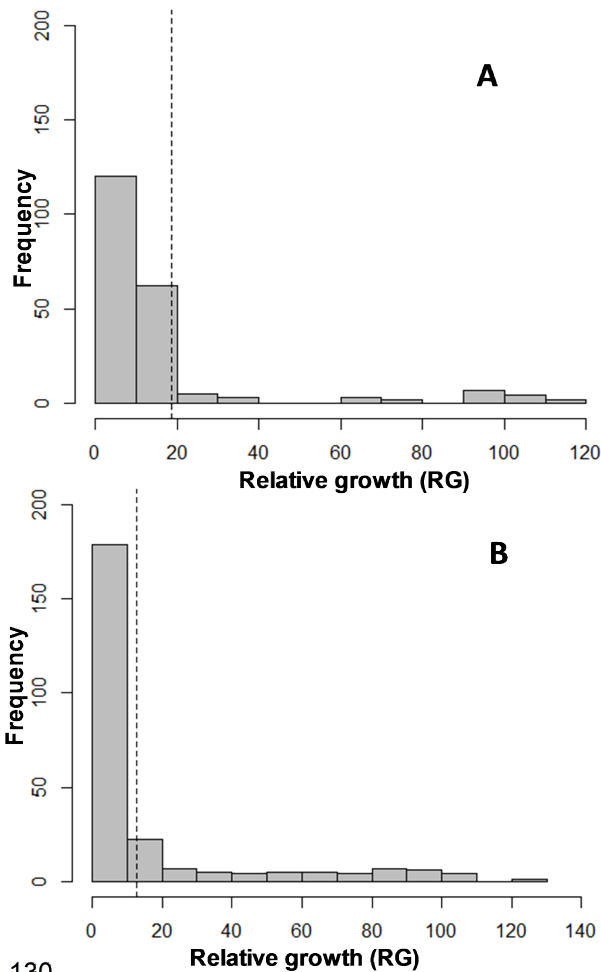

Figure 9.2. Distributions of relative growth (RG) values of *Fusicladium eriobotryae* isolates ($n=249$) on A, difenoconazole and B, thiophanate-methyl. Bars represent number of isolates in each RG category and dotted vertical lines indicate the average RG value for each fungicide

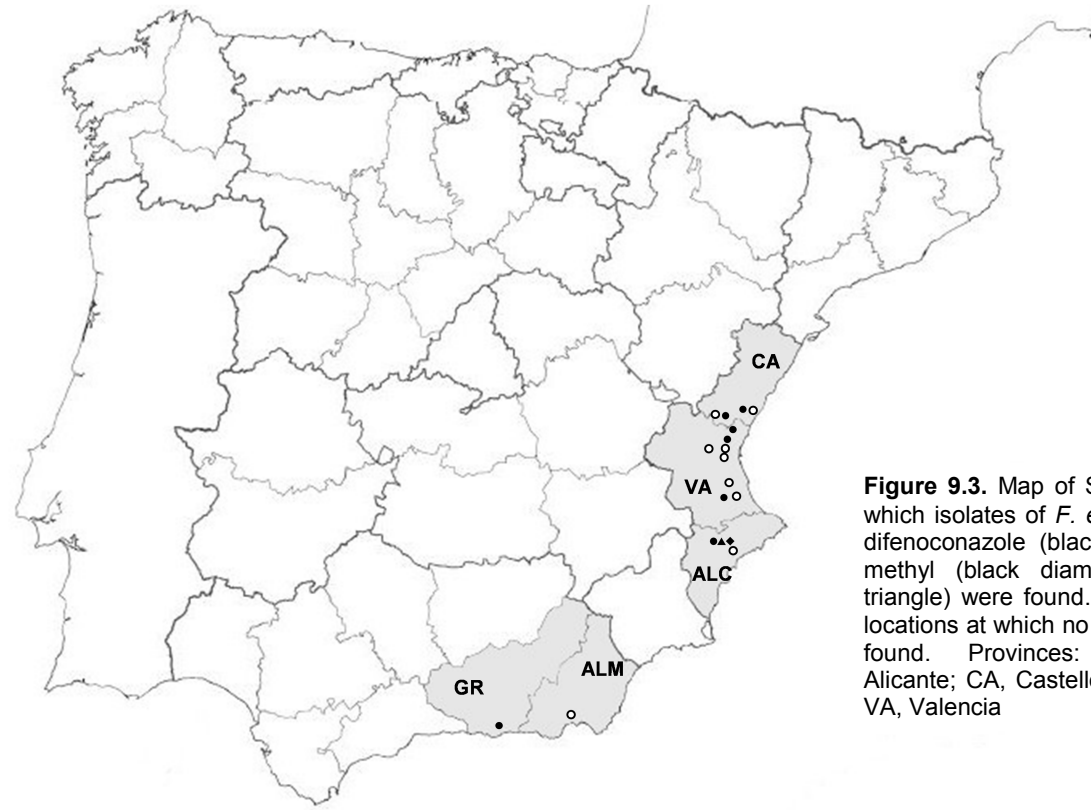

Figure 9.3. Map of Spanish locations from which isolates of *F. erobotryae* resistant to difenoconazole (black circle), thiophanate-methyl (black diamond) or both (black triangle) were found. White circles indicate locations at which no resistant isolates were found. Provinces: ALM, Almería; ALC, Alicante; CA, Castellón; GR, Granada; and VA, Valencia

Table 9.2. Primers used in the molecular characterization of *Fusicladium eriobotryae* to thiophanate-methyl.

Primers	Sequence (5'-3')	Reference
bt1a	TTCCCCCGTCTCCACTTCTTCATG	Glass and Donaldson, 1995
bt1b	GACGAGATCGTTCATGTTGAACTC	Glass and Donaldson, 1995
bt2a	GGTAACCAAATCGGTGCTGCTTTC	Glass and Donaldson, 1995
bt2b	ACCCTCAGTGTAGTGACCCTTGGC	Glass and Donaldson, 1995
T1	AACATGCGTGAGATTGTAAGT	O'Donnell and Cigelnik, 1997; Suga <i>et al.</i> , 2011
T22	TCTGGATGTTGTTGGGAATCC	O'Donnell and Cigelnik, 1997; Suga <i>et al.</i> , 2011
BtubF14	AACCAAATTGGTGCTGCCTTCTG	Quello <i>et al.</i> , 2010
BtubR	TGGAGGACATCTTAAGACCACG	Quello <i>et al.</i> , 2010

Molecular characterization of thiophanate-methyl resistant isolates. From the six primer sets tested to amplify the β -tubulin gene, the primer set BtubF14/BtubR (Table 9.2) was able to consistently amplify the higher gene length (1244 pb). The sequence of this product was compared to a *V. inaequalis* reference sequence (GenBank accession No. M97951.1) and contained the portion of the β -tubulin gene that included all positions known to affect the sensitivity to benzimidazoles in other plant pathogenic fungi (Ma and Michailides, 2005). All of the thiophanate-methyl resistant *F. eriobotryae* isolates contained a point mutation in one of the codons 198, 200 or 240 (Table 9.1). Two of them, showed a point mutation corresponding to codon 198 that would result in an aminoacid change from glutamic acid (GAG) to lysine (AAG) (Table 9.1). Isolate FE-249, previously characterized as resistant to thiophanate-methyl, had a point mutation in codon 200, which resulted in an aminoacid change from phenylalanine (TTC) to tyrosine (TAC). Finally, seven resistant isolates showed a point mutation in codon 240 that resulted in a change from leucine (CCT) to phenylalanine (CCC) (Table 9.1). None of these mutations were observed in the 23 *F. eriobotryae* isolates previously characterized as sensitive to thiophanate-methyl, either in the *V. inaequalis* reference sequence (M97951.1) (Table 9.1).

Discussion

The results of this study showed the occurrence in Spain of *F. eriobotryae* isolates with resistance to difenoconazole and thiophanate-methyl, two of the main fungicides used to manage loquat scab. In addition, our results revealed the wide distribution of isolates resistant to difenoconazole, present in 4 out of the 5 provinces surveyed (Alicante, Castellón, Granada and Valencia), while isolates resistant to thiophanate-methyl were present only in Alicante province. In this province, almost 15% of the isolates were resistant to this

fungicide and *F. erobotryae* isolates with difenoconazole/thiophanate-methyl multiple resistance were also found.

DMI fungicides were first labeled for use on tree fruits in the 1980s and resistance to this class of fungicides has been well determined in several plant pathogens worldwide (Kuck, 2005; Brent and Hollomon, 2007a). Specifically for difenoconazole, resistance has been reported in the last years in Chile for *V. inaequalis* (Henríquez *et al.*, 2011), China for *Gaeumannomyces graminis* var. *tritici* (Yun *et al.*, 2012), France and UK for *Mycosphaerella graminicola* (Leroux and Walker, 2011), and USA for *V. inaequalis* (Pfeufer and Ngugi, 2012) and *Stagonosporopsis cucurbitacearum* (Thomas *et al.*, 2012). In Spain, myclobutanil was the first DMI fungicide labeled in 1989, and difenoconazole applications are allowed since 1991 (MAGRAMA, 2014). Although no specific research has been developed in Spain regarding resistance identification to difenoconazole, resistance to other active ingredients included in the DMI class, such as fenarimol and triadimenol for *Podosphaera fusca*, have been reported in melon crops in Almería (López-Ruiz *et al.*, 2010). DMIs are classified as having a medium risk for resistance development (FRAC, 2013), but this level of risk could be influenced by the pathosystem (Brent and Hollomon, 2007a). For apple scab caused by *V. inaequalis*, the risk to develop DMI resistance is high, due to biological factors of the pathogen and characteristics of disease management (i.e. high fungicide application frequency and dose) (Brent and Hollomon, 2007a). Similarly, a high risk of resistance appearance to DMI fungicides could be expected for *F. erobotryae*, because, in several Spanish loquat producer areas, disease management has been based in that of apple scab.

The use of thiophanate-methyl began in the 1970s, and resistance was reported a few years later in *V. inaequalis* in Australia (Wicks, 1974) and USA (Jones and Walker, 1976). More recently, resistance has been again detected in *V. inaequalis* (Chapman *et al.*, 2011; Quello *et al.*, 2010), and also in other pathogens such as *M. fructicola* (Chen *et al.*, 2013a; Chen *et al.*, 2013b; Mio *et al.*, 2011) and *Cercospora beticola* (Trkulja *et al.*, 2012). In Spain, MBC resistance has been reported for *Penicillium expansum* in postharvest stored pear and apple fruit (Cabañas *et al.*, 2009) and *Botrytis cinerea* in greenhouse vegetable crops (Raposo *et al.*, 1996). Moreover, Martín and Martín (2013) found resistance to a fungicide containing carbendazim (MBC) and flusilazole (DMI) in isolates of *Phaeoacremonium aleophilum* infecting grapevines in several Spanish locations.

For *F. eriobotryae*, resistance appearance to thiophanate-methyl was restricted to Alicante province. Currently, although this fungicide is labeled for loquat, it is not included in the list of fungicides recommended by the regional plant health service (GVA, 2013), and its use has decreased in the last years (E. Soler, *personal communication*). However, in the population of other fungal pathogens, MBC resistance has been found to persist, even in the absence of use, for time periods above 5 years (Koch *et al.*, 2009). Therefore, field resistance identification to thiophanate-methyl might not necessary be associated to recent fungicide applications.

In the present study, thiophanate-methyl resistance has been associated with point mutations at one of these positions: 198, 200 or 240 of the β -tubulin gene. These results coincide with numerous studies where changes at codons 6, 50, 167, 198, 200, or 240 in the β -tubulin gene caused benzimidazole resistance in field isolates of pathogenic fungi (Ma and Michailides, 2005). For *F. eriobotryae*, thiophanate-methyl resistance was mainly associated with L240F mutation (7 out of the 10 resistant isolates identified). This mutation has been previously found in resistant isolates of *V. inaequalis* (Quello *et al.*, 2010) and *Pyrenopeziza brassicae* (Carter *et al.*, 2013). In general, the most frequently mutation associated to thiophanate-methyl resistance has occurred in codon 198, being reported in numerous pathogens such as *M. fructicola* (Mio *et al.*, 2011), *P. brassicae* (Carter *et al.*, 2013) or *V. inaequalis* (Koenraadt *et al.*, 1992). However, in our case, only two isolates showed E198K mutation. Finally, F200Y mutation, observed in one *F. eriobotryae* resistant isolate, had been previously described for *V. inaequalis* (Koenraadt *et al.*, 1992) and *M. fructicola* (Chen *et al.*, 2013b).

The molecular characterization of thiophanate-methyl resistance in *F. eriobotryae* set up the basis to develop a method to easily detect fungicide resistance. For this purpose, DNA-based methods are considered more reliable and time-efficient than traditional methods (Ma and Michailides, 2005). Previously, PCR-RFLP and specific PCR protocols have been developed to detect resistance in *M. laxa* (Ma *et al.*, 2005), *Alternaria* spp. (Ma *et al.*, 2003) or *V. inaequalis* (Quello *et al.*, 2010). In a recent work, Liu *et al.* (2013) have developed a quantitative specific real-time PCR methodology to determine the frequencies of five different variants (F167Y, F200Y, E198Q, E198L and E198K) in the β -tubulin gen responsible for carbendazim resistance in *Gibberella zeae*.

Further research is needed to characterize the molecular changes involved in *F. eriobotryae* resistance to difenoconazole. Although in some pathogens resistance to DMIs has been associated with point mutations in the 14 α -demethylase (CYP51) gene (Ma and Michailides, 2005), for others, such as

V. inaequalis (Schnabel and Jones, 2000) or *Sclerotinia homoeocarpa* (Ma and Tredway, 2013), the overexpression of this gene seems to be responsible of the appearance of resistant isolates. For *F. eriobotryae*, the CYP51 gene could be cloned, amplified and sequenced in order to elucidate which mechanism is involved in difenoconazole resistance.

The development of DNA-based protocols for the detection of *F. eriobotryae* resistant isolates to thiophanate-methyl and difenoconazole would facilitate systematic sampling of loquat orchards in the main cultivation areas. Regarding the current situation of field fungicide resistance in these areas, results of this work reveal that, to date, the frequency of *F. eriobotryae* isolates resistant to thiophanate-methyl and difenoconazole is low. However, the intensive use of site-specific fungicides, mainly difenoconazole, in loquat orchards could increase the incidence of resistance and, therefore compromise disease management in the future. To avoid that, growers should take into account some general recommendations for fungicide treatments: (i) avoid repetitive and sole use, (ii) appropriately mix or alternate these fungicides, (iii) maintain recommended dose rate and, (iv) limit the number and timing of treatments (Brent and Hollomon, 2007a). For the first two issues, in Alicante province (GVA, 2013) the regional plant health service recommends using site-specific fungicides mixed with multi-site protectant dithio-carbamates (mancozeb, maneb or metiram). However, according to our results, this recommendation should be transferred to the rest of the Spanish areas where loquat is cultivated. For the last issue, the epidemiological model previously developed to schedule fungicide applications in loquat orchards (González-Domínguez *et al.*, 2014a) can contribute to optimize and reduce the number of treatments.

Acknowledgements

We thank loquat growers, researchers and technicians from the provinces surveyed, who helped us visiting the fields. We thank A. Guillem-Amat for technical assistance.

Chapter 10

GENERAL DISCUSSION

The study of loquat scab has been addressed globally in this thesis for the first time, leading to a better knowledge about the biology and epidemiology of *Fusicladium eriobotryae*. This research has been developed from a practical approach and with the overall aim of assist the needs of field technicians and farmers who require specific tools to manage the disease.

First of all, the effect of environmental factors on mycelial growth, conidial germination and the infection of loquat leaves by *F. eriobotryae* was studied and equations describing these processes were developed. Mycelium of *F. eriobotryae* was able to grow and conidia to germinate in a wide range of temperatures (5-30°C), although more conidia germinated and the mycelium grew faster between 15 and 25°C. Substantial germination of *F. eriobotryae* conidia occurred only after 12 h of wetness and its viability was reduced by dry periods. Infection of loquat leaves by *F. eriobotryae* occurred between 10 and 20°C and with at least 12 h of wetness.

In addition, field experiments were conducted to investigate the dispersal of *F. eriobotryae* and the spatial pattern of loquat scab. Our results demonstrated that conidia of *F. eriobotryae* are dispersed through rain splash, mainly during rainy periods (>0.2 mm of rain). Moreover, strong aggregation of loquat scab incidence was observed into the canopy of loquat trees and between them, a spatial pattern characteristic of rain splash pathogens (Waggoner and Rich, 1981; Madden, 1992).

Results obtained showed that *F. eriobotryae* has similar environmental requirements for spore dispersal, mycelial growth, conidial germination and infection than *Fusicladium oleagineum* and *Fusicladium carpophilum*, causal agents of olive and peach scab, respectively (Gottwald, 1983; Lops *et al.*, 1993; Lan and Scherm, 2003; Obanor *et al.*, 2008b; Obanor *et al.*, 2010; Viruega *et al.*, 2011). However, considerable differences have been observed among the environmental requirements of *F. eriobotryae* and the anamorph stages of other Venturiaceae, such as *Venturia inaequalis* on apple, *Venturia pyrina* and *Venturia nashicola* on pear, and *Fusicladium effusum* on pecan. Conidia of these species require less hours of wetness for germination and infection (Gottwald, 1985; Spotts and Cervantes, 1991; Hartman *et al.*, 1999; Villalta *et al.*, 2000b), and conidia of *V. inaequalis* and *V. nashicola* are able to germinate in the absence of free water (MacHardy, 1996; Li *et al.*, 2003). Moreover, conidia of *V. inaequalis* are also dispersed in periods without rain (Hirst and Stedman,

1961; Sutton *et al.*, 1976; Gottwald, 1985; Hartman *et al.*, 1999). Therefore, it seems that scab diseases of Mediterranean crops, such as those of loquat, olive and peach are adapted to a warm, dry climate, with low annual rainfall, distributed mainly in autumn and spring (Csa climate class) (Graniti, 1990; Kottek *et al.*, 2006).

Under this assumption, conidial dispersal of *F. eriobotryae*, *F. oleagineum* and *F. carpophilum* are restricted to rainy periods, in which they have a greater probability of experiencing the quantity of hours with wetness required for germination and infection. Graniti (1990), indicated that Mediterranean diseases are adapted to the seasonal irregularity of this climate, and for *F. oleagineum*, the intensity and frequency of rain events defined better the risk of disease to appear than the average environmental values for long periods of time. In the case of *F. eriobotryae*, the use of Mills-Laplanche tables (Mills and Laplanche, 1954) to estimate the risk of infection could over-predict the number of loquat scab infections, because the requirements of this fungus are more stringent than those of conidia of *V. inaequalis*. Moreover, it has been previously reported that, even for apple scab, Mills-Laplanche tables over-predict the number of infections (Li *et al.*, 2007; MacHardy *et al.*, 1989).

Therefore, in order to improve the management of loquat scab, specific tools adapted to the biology and epidemiology of *F. eriobotryae* are needed. For this reason, a weather-based model was developed to predict the infection of loquat fruits by conidia of *F. eriobotryae*. The model used the mathematic equations obtained from the previous data of growth, conidial germination and infection of *F. eriobotryae*, and considered that any rain (i.e. >0.2 mm) is able to disperse the conidia of the pathogen. A mechanistic approach described the infection process, considering the sub-processes of spore dispersal, infection, and latency (De Wolf and Isard, 2007; Krause and Massie, 1975; Rossi *et al.*, 2010). The model was validated during three growing seasons, showing that it was able to predict the occurrence of infection periods and the severity of the disease. The accuracy of the model was also confirmed by the comparison of model output in seven growing seasons with expert assessment of loquat scab severity.

As a tool for model evaluation, and for further assessments of loquat scab severity, a standard area diagram set (SAD) was developed. The SAD consists of eight black and white images exhibiting the typical symptom patterns of loquat scab on fruits. The SAD improve the accuracy and reliability of the estimates by inexperienced rather than experienced raters, which is in agreement with previous reports in other plant pathogens (Godoy *et al.*, 2006; Pedroso *et al.*, 2011; Yadav *et al.*, 2013). This confirms that experienced raters

did not benefit significantly from the use of SADs. Thus, the SADs developed in this thesis will be a valuable tool for the estimation of loquat scab severity when raters are not familiarized with disease assessment.

Another valuable tool developed in this thesis is the PCR-based protocol for *F. eriobotryae* identification. A specific primer was designed in the elongation factor1- α (EF1- α) gen that combined with the universal one EF1-986R (Carbone and Kohn, 1999), was able to differentiate *F. eriobotryae* from the related species *V. inaequalis*, *V. pyrina* and *F. oleagineum*. This protocol can be useful for further epidemiological research, making the quantification of airborne inoculum more faster and accurate, because of the similarity among conidia of *F. eriobotryae* and those of other *Venturia* spp., such as *V. inaequalis* or *V. pyrina* (Schubert *et al.*, 2003). Moreover, it will facilitate the detection of the pathogen in asymptomatic tissues before symptoms appearance, an interesting tool because of the long period of incubation of *F. eriobotryae* (more than 21 days).

One of the goals of this thesis was to evaluate the efficacy of the main fungicide classes against *F. eriobotryae*. The results demonstrated that the fungicides currently recommended in Spain by the regional plant health services against loquat scab (GVA, 2013) provide a good disease control. Pyraclostrobin and boscalid, fungicides actually not labelled for loquat scab control, displayed also good results. Difenconazole and pyraclostrobin were effective even when they were applied 7 days before or after *F. eriobotryae* infection. The good post-infection activity of pyraclostrobin had been previously reported for *Phomopsis citri* and *Alternaria alternata* in citrus (Mondal *et al.*, 2007), although for difenoconazole, its post-infection activity was reduced to 3 days in the case of *V. inaequalis* (Dahmen and Staub, 1992) and *F. oleagineum* (Obanor *et al.*, 2008a). Mancozeb showed good pre-infection activity against *F. eriobotryae*, whereas values up to 20% of relative disease severity were obtained with copper oxychloride. These results are in agreement with the common concept that copper and mancozeb are multi-site protectant-only fungicides (Hewitt, 1998).

Isolates of *F. eriobotryae* resistant to difenoconazole and/or thiophanate-methyl were detected in the main loquat cultivation areas of Spain. In general, the risk of resistance appearance for thiophanate-methyl is high (FRAC, 2013) and there are previous reports of resistance appearance in numerous pathogens such as *V. inaequalis* (Wicks, 1974; Quello *et al.*, 2010; Chapman *et al.*, 2011) and *Monillinia fructicola* (Mio *et al.*, 2011; Chen *et al.*, 2013a; 2013b). For difenoconazole, the appearance of resistance has been reported in the last years in *V. inaequalis* (Henríquez *et al.*, 2011; Pfeufer and Ngugi, 2012), and *Mycosphaerella graminicola* (Leroux and Walker, 2011). For apple scab caused by *V. inaequalis*, the risk to develop resistance to DeMethylation Inhibitors

fungicides (DMI) is high, due to biological factors of the pathogen and characteristics of disease management (i.e. high fungicide application frequency and dose) (Brent and Hollomon, 2007a). Similarly, a high risk of resistance appearance to DMI fungicides could be expected for *F. eriobotryae*, because, in several Spanish loquat producing areas, disease management has been based in that of apple scab. For thiophanate-methyl, the resistance in *F. eriobotryae* was associated to point mutations in the β - tubulin gene, as it has been previously reported for several fungal pathogens (Ma and Michailides, 2005).

All together, the results obtained in this thesis represent an improvement in the knowledge of the biology and epidemiology of *F. eriobotryae*, a pathogen that has been little studied worldwide. Moreover, the thesis provides valuable tools for *F. eriobotryae* detection, and the assessment and management of loquat scab, which are now available for loquat growers and field technicians. However, further research is needed to: (i) ensure the applicability of the epidemiological model developed, and (ii) increase the information about the inoculum sources of *F. eriobotryae*, focusing in the overwintering forms of the pathogen.

For model applicability, the first and essential step is to define appropriate thresholds of model output for fungicide scheduling. To evaluate the suitability of these thresholds and optimize the number of treatments, field trials should be performed during several growing seasons and in different cultivation areas (Llorente *et al.*, 2000; Caffi *et al.*, 2009; 2012). Together with model validation, different fungicide strategies should be tested in field trials. The existence of *F. eriobotryae* resistant isolates to difenoconazole and thiophanate-methyl should encourage loquat growers to mix or alternate fungicides with different mode of actions (Brent and Hollomon, 2007a). Pyraclostrobin and boscalid could also be included in this trials due to its good results *in vitro* and *in planta*. However, the risk of fungal resistance to pyraclostrobin is high (FRAC, 2013), thus no more than one application per season should be proposed.

In order to increase the information about the inoculum sources of *F. eriobotryae*, the effect of environmental factors in the sporulation and latency (i.e. period from the time of infection to the start of sporulation) of *F. eriobotryae*, should be studied in detail. Although Prota (1960) and Salerno (1971a), obtained preliminary data from field observations, further experiments should be performed to obtain mathematic equations that could be integrated in the epidemiological model described in this thesis, in order to improve its accuracy. Moreover, a better knowledge of the overwintering of *F. eriobotryae* is needed. As indicated in the introduction of this thesis, the ability of *F. eriobotryae* to infect

loquat flowers is not clear. The specific nested-PCR protocol developed in this thesis could be used to detect *F. eriobotryae* in this organ.

In the absence of precise information regarding sporulation, latency and overwintering forms of *F. eriobotryae*, and taking into consideration previous field studies (Prota, 1960; Salerno *et al.*, 1971a), the epidemiological model developed in this thesis assumes that viable conidia are always present in loquat orchards. This assumption is precautionary but can lead to over prediction of infection and thus, to unnecessary applications of fungicides, associated with costs for growers, consumers, and the environment (Shtienberg, 2013).

Finally, in the future, field systematic sampling should be done to evaluate the range of resistance in *F. eriobotryae* population to the fungicides commonly used to control loquat scab. For this objective, DNA-based methods are considered more reliable and time-efficient than traditional methods (Ma and Michailides, 2005). For thiophanate-methyl, the molecular characterization of *F. eriobotryae* resistance will facilitate the development of a specific PCR protocol to detect resistant isolates. For difenoconazole, the molecular characterization of resistance in *F. eriobotryae* is necessary to develop a DNA-based protocol for detection. This resistance has been associated with point mutations or overexpression on 14 α -demethylase (CYP51) gene (Ma and Michailides, 2005). For *F. eriobotryae*, CYP51 gene should be cloned, amplified and sequenced in order to elucidate which mechanism is involved in difenoconazole resistance.

Chapter 11

CONCLUSIONS

1- Mycelium of *F. eriobotryae* was able to grow and conidia to germinate in a wide range of temperatures (5-30°C), although more conidia germinated and the mycelium grew faster between 15 and 25°C. Substantial germination of *F. eriobotryae* conidia occurred only after 12 h of wetness and its viability was reduced by dry periods. Infection of loquat leaves by *F. eriobotryae* occurred between 10 and 20°C and with at least 12 h of continuous wetness.

2- Conidia of *F. eriobotryae* are dispersed primarily through rain splash. During field assays conducted in two growing seasons, *F. eriobotryae* conidia were collected between March and May and 90% of them in rainy periods. Using ≥ 0.2 mm of rainfall as a cut-off value resulted in a high probability of correctly predicting actual conidial dispersal, with a low probability of failing, based on ROC and Bayesian analysis. Strong aggregation of loquat scab was observed between and within loquat trees, and this aggregation was influenced by disease incidence and year of assessment.

3- The environmental conditions for growth, germination, infection and dispersal of *F. eriobotryae* are similar to those of *F. oleagineum* and *F. carpophilum*. Dispersion of these pathogens is restricted to rainy periods, in which they have a greater probability of experiencing the quantity of hours with wetness required for germination and infection. The biology of *F. eriobotryae* is well adapted to Mediterranean conditions.

4- A standard area diagram set (SAD) was developed to aid visual assessment of loquat scab severity on fruit. The SAD improved the accuracy and reliability of the estimates by inexperienced raters.

5- A mechanistic, dynamic, weather-based model was developed to predict infection of loquat fruit by conidia of *F. eriobotryae*. The model simulates scab infection periods and their severity through the sub-processes of spore dispersal, infection, and latency. The model accurately predicts the occurrence and severity of infection periods as well as the progress of loquat scab incidence on fruit. The use of the model for scheduling fungicide applications in loquat orchards may help to optimize scab management and reduce the number of fungicide applications.

6- A nested polymerase chain reaction based protocol was developed for *F. eriobotryae*-specific identification from pure culture or infected loquat tissues. This protocol can be useful for routine diagnosis, disease monitoring programs and epidemiological research.

7- Boscalid, chlorothalonil, didecyldimethyl ammonium chloride and pyraclostrobin were able to reduce both, conidial germination and mycelial growth of *F. erobotryae*. Difenconazole and pyraclostrobin applications were able to control the disease even when applied 7 days before or after inoculation. Boscalid and mancozeb showed good pre-infection activity against *F. erobotryae*.

8- A wide distribution of *F. erobotryae* isolates resistant to difenoconazole, present in 4 out of the 5 provinces surveyed, was found, while isolates resistant to thiophanate-methyl were present only in Alicante province. In this province, almost 15% of the isolates were resistant to this fungicide and *F. erobotryae* isolates with difenoconazole/thiophanate-methyl multiple resistance were also found. Results showed that all of the *F. erobotryae* isolates resistant to thiophanate-methyl contained one of the aminoacid substitutions E198K, F200Y or L240F in the β -tubulin gene.

References

REFERENCES

- Abbasi NA, Hussain A, Hafiz IA, 2011. Loquat production in Pakistan and strategies for improvement. *Acta Horticulturae* 887, 117-121.
- Alavanja MCR, Hoppin JA, Kamel F, 2004. Health effects of chronic pesticide exposure, cancer and neurotoxicity. *Annual Review of Public Health* 25, 155-197.
- Alippi A, Alippi H, 1990. Cancrosis del níspero, una nueva enfermedad para la Argentina. *Revista Argentina de Microbiología* 22, 155-158.
- Alves A, Crous PW, Correia A, Phillips AJL, 2008. Morphological and molecular data reveal cryptic speciation in *Lasiodiplodia theobromae*. *Fungal Diversity* 28, 1-13.
- Amponsah NT, Jones EE, Ridgway HJ, Jaspers MV, 2009. Rainwater dispersal of *Botryosphaeria* conidia from infected grapevines. *New Zealand Plant Protection* 62, 228-233.
- Andrade N, Aruta C, Montealegre J, 1984. La sarna del níspero, *Spilocaea pyracanthae* (Oth) Von. *Revista Frutícola* 5, 60-61.
- Avidan B, Klein I, 2003. Physiological disorders in loquat (*Eriobotrya japonica* Lindl.). *Options Mediterranie*s 95, 87-95.
- Bardsley SJ, Ngugi HK, 2013. Reliability and accuracy of visual methods to quantify severity of foliar bacterial spot symptoms on peach and nectarine. *Plant Pathology* 62, 460-474.
- Becker CM, Burr TJ, 1994. Discontinuous wetting and survival of conidia of *Venturia inaequalis* on apple leaves. *Phytopathology* 84, 372-378.
- Bennett JC, Diggle A, Evans F, Renton M, 2012. Assessing eradication strategies for rain-splashed and wind-dispersed crop diseases. *Pest Management Science* 69, 955-963.
- Berbegal M, Armengol J, García-Jiménez J, 2011. Evaluation of fungicides to control circular leaf spot of persimmon caused by *Mycosphaerella nawae*. *Crop Protection* 30, 1461-1468.
- Berbegal M, Mora-Sala B, García-Jiménez J, 2013. A nested-polymerase chain reaction protocol for the detection of *Mycosphaerella nawae* in persimmon. *European Journal of Plant Pathology* 137, 273-281.

- Besoain X, Fuentes H, 1988. Cancrosis en níspero (*E. japonica*) causado por *Botryosphaeria dothidea* y su incidencia en la zona de Quillota. *Simiente* 58, 37.
- Bock CH, Parker PE, Cook AZ, Gottwald TR, 2008. Characteristics of the perception of different severity measures of citrus canker and the relations between the various symptom types. *Plant Disease* 92, 927-939.
- Bock CH, Parker PE, Cook AZ, Riley T, Gottwald TR, 2009. Comparison of assessment of citrus canker foliar symptoms by experienced and inexperienced raters. *Plant Disease* 93, 412-424.
- Bock CH, Poole G, Parker PE, Gottwald TR, 2010. Plant disease severity estimated visually by digital photography and image analysis and by hyperspectral imaging. *Critical Reviews in Plant Sciences* 29, 59-107.
- Bock CH, Gottwald TR, Parker PE, 2011a. Distribution of canker lesions on the surface of diseased grapefruit. *Plant Pathology* 60, 986-991.
- Bock CH, Hotchkiss MW, Okie WR, Wood BW, 2011b. The distribution of peach scab lesions on the surface of diseased peaches. *European Journal of Plant Pathology* 130, 393-402.
- Bock CH, Cottrell TE, Hotchkiss MW, Wood BW, Road D, 2013a. Vertical distribution of scab in large pecan trees. *Plant Disease* 97, 626-634.
- Bock CH, Wood BW, van den Bosch F, Parnell S, Gottwald TR, 2013b. The effect of Horsfall-Barratt category size on the accuracy and reliability of estimates of pecan scab severity. *Plant Disease* 97, 797-806.
- Boller E, Avilla J, Joerg E, Malavolta C, Wijnands F, Esbjerg P, 2004. Integrated production principles and technical guidelines. *IOBC Bulletin* 21,1-34.
- Boric B, 1985. Influence of temperature on germability of spores of *Venturia inaequalis* (Cooke) Winter, and their viability as affected by age. *Zastita Bilja* 36, 295-302.
- Braun U, Ritschel A, Schubert K, 2002. Proposal to conserve the generic name *Fusicladium* against *Spilocaea* (Hyphomycetes). *Taxon* 51, 557.
- Brent KJ, Hollomon DW, 2007a. *Fungicide resistance in crop pathogens: How can it be managed?*. FRAC Monograph N° 1. Fungicide Resistance Action Committee, Brussels, Belgium, 56 pp.
- Brent KJ, Hollomon DW, 2007b. *Fungicide resistance, the assessment of risk*. FRAC Monograph N° 1. Fungicide Resistance Action Committee, Brussels, Belgium, 52 pp.
- Briosi G, Cavara F. 1892. I Funghi Parassiti delle Piante Coltivate od *Utili* 186,7-8.

- Buck AL, 1981. New equations for computing vapour pressure and enhancement factor. *Journal of Applied meteorology* 20, 1527-1532.
- Caballero P, Fernández MA, 2002. Loquat, production and market. *Options Mediterranieas* 58, 11-20.
- Cabañas R, Castellá G, Abarca ML, Bragulat MR, Cabañes FJ, 2009. Thiabendazole resistance and mutations in the beta-tubulin gene of *Penicillium expansum* strains isolated from apples and pears with blue mold decay. *FEMS Microbiology Letters* 297, 189-195.
- Caffi T, Rossi V, Bugiani R, Spanna F, Flamini L, Cossu A, Nigro C, 2009. A model predicting primary infections of *Plasmopara viticola* in different grapevine-growing areas of Italy. *Journal of Plant Pathology* 91, 535-548.
- Caffi T, Legler SE, Rossi V, Bugiani R, 2012. Evaluation of a warning system for early-season control of grapevine powdery mildew. *Plant Disease* 96, 104-110.
- Caffi T, Gilardi G, Monchiero M, Rossi V, 2013. Production and release of asexual sporangia in *Plasmopara viticola*. *Phytopathology*, 103, 64-73.
- Calabrese F, 2006. Origen de la especie. In: *El Cultivo del Níspero Japonés*. M. Agustí, C. Reig, P. Undurraga (Eds.), Pontificia Universidad Católica de Valparaíso, Valparaíso, Chile and Universidad Politécnica de Valencia, Valencia, España, pp 17-26.
- Campbell CL, Madden LV, 1990. *Introduction to plant disease epidemiology*. Wiley, New York. NY, USA, 532pp.
- Capucho AS, Zambolim L, Duarte HSS, Vaz GRO, 2011. Development and validation of a standard area diagram set to estimate severity of leaf rust in *Coffea arabica* and *C. canephora*. *Plant Pathology* 60, 1144-1150.
- Carbone I, Kohn LM, 1999. A method for designing primer sets for speciation studies in filamentous ascomycetes. *Mycologia* 91, 553-556.
- Carisse O, Rolland D, Talbot B, Savary S, 2006. Heterogeneity of the aerial concentration and deposition of ascospores of *Venturia inaequalis* within a tree canopy during the rain. *European Journal of Plant Pathology* 117, 13-24.
- Carisse O, Meloche C, Boivin G, Jobin T, 2009. Action thresholds for summer fungicide sprays and sequential classification of apple scab incidence. *Plant Disease* 93, 490-498.

- Carisse O, Meloche C, Turechek WW, 2011. Spatial heterogeneity, incidence-incidence and incidence-lesion density relationship of apple scab (*Venturia inaequalis*) in managed orchards. *European Journal of Plant Pathology* 130, 349-365.
- Carter HE, Cools HJ, West JS, Shaw MW, Fraaije BA, 2013. Detection and molecular characterisation of *Pyrenopeziza brassicae* isolates resistant to methyl benzimidazole carbamates. *Pest Management Science* 69, 1040-1048.
- Celikyurt MA, Sayin B, Tepe S, 2011. Loquat production in the west mediterranean region of Turkey. *Acta Horticulturae* 887, 127-129.
- Chapman KS, Sundin GW, Beckerman JL, 2011. Identification of resistance to multiple fungicides in field populations of *Venturia inaequalis*. *Plant Disease* 95, 921-926.
- Chen F, Liu X, Chen S, Schnabel EL, Schnabel G, 2013a. Characterization of *Monilinia fructicola* strains resistant to both propiconazole and boscalid. *Plant Disease* 97, 645-651.
- Chen F, Liu X, Schnabel G, 2013b. Field strains of *Monilinia fructicola* resistant to both MBC and DMI fungicides isolated from stone fruit orchards in the Eastern United States. *Plant Disease* 97, 1063-1068.
- Chern LL, Ann PJ, Young HR, 1998. Root and foot rot of loquat in Taiwan caused by *Phytophthora*. *Phytopathology* 82, 651-656.
- Clewer AG, Scarisbrick DH, 2001. *Practical statistics and experimental design for plant and crop science*. John Wiley and Sons Ltd, Chichester, UK, 346pp.
- Condit IJ, 1915. The loquat. *Bulletin University of California* 250.
- Corrêa FM, Filho JSS, Carmo MGF, 2009. Comparison of three diagrammatic keys for the quantification of late blight in tomato leaves. *Plant Pathology* 58, 1128-1133.
- Crane JH, Caldeira ML, 2013. *Loquat growing in the Florida home landscape*. HS5 Institute of Food and Agricultural Sciences, University of Florida
- D'Oliveira B, D'Oliveira M, 1946. Nota sobre os corpos M do tricoginio e do anteridio nas *Venturia inaequalis*, *V. pirina* e *V. eriobotryae*. *Agronomia Lusitana*, 8.
- Dahmen H, Staub T, 1992. Protective, curative, and eradicator activity of difenoconazole against *Venturia inaequalis*, *Cercospora arachidicola*, and *Alternaria solani*. *Plant Disease* 76, 774-777.

- De Marzo L, Frisullo S, Lops F, Rossi V, 1993. Possible dissemination of *Spilocaea oleagina* conidia by insects (*Ectopsocus briggsi*). *EPPO Bulletin* 23, 389-391.
- De Wolf ED, Isard SA, 2007. Disease cycle approach to plant disease prediction. *Annual Review of Phytopathology* 45, 203-220.
- Diaz CG, Bassanezi RB, Bergamin Filho, A, 2001. Desenvolvimento e validação de uma escala diagramática para *Xanthomonas axonopodis* pv. *phaseoli* em feijoeiro. *Summa Phytopathologica* 27, 35-39.
- Dhingra OD, Sinclair JB, 1985. *Basic plant pathology methods*. CRC Press, Inc Boca Raton, FL, USA, 434 pp.
- DRA, 2014. *Disciplinare regionale di produzione integrata, norme tecniche di difesa integrata delle colture e controllo delle infestanti*. Assessorato regionale dell'agricoltura, dello sviluppo rurale e della pesca mediterranea. Dipartimento regionale dell'agricoltura. Regione Siciliana. 268 pp.
- Duan CH, Tsai I-I W, Tu CC, 1990. Dissemination of white root rot disease of loquat and its control. *Journal of Agricultural Research of China* 39,47-54.
- Eikemo H, Gadoury DM, Spotts RA, Villalta O, Creemers P, Seem RC, Stensvand A, 2011. Evaluation of six models to estimate ascospore maturation in *Venturia pyrina*. *Plant Disease* 95, 279-284.
- Elsabagh AS, 2011. Production of loquat in Egypt. *Acta Horticulturae* 887, 123-125.
- EU, 1991. Council Directive 91/414 of 15 July 1991 concerning the placing of plant protection products on the market. *Official Journal of the European Communities* No L230, 1-32.
- Fang L, Wang HR, 2013. Branch blight of loquat caused by *Pestalotiopsis sydowiana* in China. *Plant Disease* 97, 990.
- Fichet T, Razeto B, 2002. Current status of loquat in Chile. *Options Mediterranie* 58, 21-23.
- Fitt BDL, McCartney HA, Walklate PJ, 1989. The role of rain in dispersal of pathogen inoculum. *Annual Review of Phytopathology* 27, 241-270.
- Forbes GA, Korva JT, 1994. The effect of using Horsfall-Barratt scale on precision and accuracy of visual estimation of potato late blight severity in the field. *Plant Pathology* 43, 675-682.
- Fourie P, Schutte T, Serfontein S, Swart F, 2013. Modeling the effect of temperature and wetness on *Guignardia pseudothecium* maturation and ascospore release in citrus orchards. *Phytopathology* 103, 281-292.

- FRAC, 2013. *FRAC code list 2013: Fungicides sorted by mode of action*. www.frac.info.
- Frey CN, Keitt, GW, 1925. Studies of spore dissemination of *Venturia inaequalis* (Cke) Wint in relation to seasonal development of apple scab. *Journal of Agricultural Research* 30, 529-540.
- Frisullo S, Cacciola SO, Pane A, 1997. Disseccamenti rameali del nespolo del Giappone causati da *Phytophthora cactorum*. *Informatore Fitopatologico* 12, 30-32.
- Gadoury DM, MacHardy WE, 1982. A model to estimate the maturity of ascospores of *Venturia inaequalis*. *Phytopathology* 72, 901-904.
- Gadoury D, MacHardy WE, 1986. Forecasting ascospore dose of *Venturia inaequalis* in commercial apple orchards. *Phytopathology* 76, 112-118.
- Gamer M, Lemon J, Fellows I, 2012. *irr, Various Coefficients of Interrater Reliability and Agreement R Package Version 084*. <http://CRAN.R-project.org/package=irr>.
- Gardes M, Bruns TD, 1993, ITS primers with enhanced specificity for basidiomycetes - application to the identification of mycorrhizae and rusts. *Molecular Ecology* 2, 113-118.
- Gariglio N, Castillo A, Alós E, Juan M, Almela V, Agustí M, 2003. The influences of environmental factors on the development of purple spot of loquat fruit (*Eriobotrya japonica* Lindl). *Science Horticulturae* 98, 17-23.
- Gent DH, De Wolf E, Pethybridge SJ, 2011. Perceptions of risk, risk aversion, and barriers to adoption of decision support systems and integrated pest management, an introduction. *Phytopathology* 101, 640-643.
- Gent DH, Mahaffee WF, McRoberts N, Pfender WF, 2013. The use and role of predictive systems in disease management. *Annual Review of Phytopathology* 51, 267-289.
- Ghanbarnia K, Dilantha Fernando WG, Crow G, 2009. Developing rainfall- and temperature-based models to describe infection of canola under field conditions caused by pycnidiospores of *Leptosphaeria maculans*. *Phytopathology* 99, 879-886.
- Gilligan CA, van den Bosch F, 2008. Epidemiological models for invasion and persistence of pathogens. *Annual Review of Phytopathology* 46, 385-418.
- Giosuè S, Bugiani R, Caffi T, Pradolesi GF, Melandri M, Bevilacqua T, Rossi V, 2010. Used of the A-scab model for rational control of apple scab. *IOBC WPRS Bulletin* 54, 345-349.

- Giraud T, Refrégier G, Le Gac M, de Vienne, DM, Hood ME, 2008. Speciation in fungi. *Fungal Genetics and Biology* 45, 791-802.
- Gisbert AD, Besoain X, Llácer G, Badenes ML, 2006. Protección de cultivo II, Enfermedades. In: Agustí M, Reig C, Undurraga P (Eds.). *El Cultivo del Níspero Japonés*. Pontificia Universidad Católica de Valparaíso, Valparaíso, Chile and Universidad Politécnica de Valencia, Valencia, España, 205 pp.
- Gisbert AD, Reig C, Gariglio N, Badenes ML, 2007. Frutales menores. El níspero japonés como ejemplo: situación actual, problemas y perspectivas. *Actas de Horticultura* 48, 624-630.
- Gladieux P, Caffier V, Devaux M, Le Cam B, 2010. Host-specific differentiation among populations of *Venturia inaequalis* causing scab on apple, pyracantha and loquat. *Fungal Genetics and Biology* 47, 511-521.
- Glass LN, Donaldson GC, 1995. Development of primer sets designed for use with the PCR to amplify conserved genes from filamentous Ascomycetes. *Applied and Environmental Microbiology*, 61, 1323-1330.
- Godoy CV, Carneiro SMTPG, Iamauti MT, Dalla Pria M, Amorim L, Berger RD, Bergamim Filho A, 1997. Diagrammatic scale for bean, development and validation. *Journal of Plant Diseases and Protection* 104, 336-345.
- Godoy CV, Koga LJ, Canteri MG, 2006. Diagrammatic scale for assessment of soybean rust severity. *Fitopatologia Brasileira* 31, 63-68.
- Gomes AMA, Michereff SJ, Mariano RLR, 2004. Development and validation of a diagrammatic key for *Cercospora* leaf spot of lettuce. *Summa Phytopathologica* 30, 38-42.
- Gómez A, 1988. Enfermedades en Chile. In: *Frutales no tradicionales, kaki, feijoa, níspero, zarzaparrilla*. Facultad Ciencias Agronómicas y Forestales Universidad de Chile Publicaciones Misceláneas Agrícolas N° 20.
- González-Domínguez E, Pérez-Sierra A, Álvarez A, León M, Abad-Campos P, Armengol J, García-Jiménez J, 2009. Agentes fúngicos presentes en plantaciones de nísperos (*Eriobotrya japonica* Lindl.) con síntomas de decaimiento en la provincia de Alicante. *Boletín de Sanidad Vegetal y Plagas* 35, 453-467.
- González-Domínguez E, León M, Armengol J, 2012. Hongos de la familia Botryosphaeriaceae asociados a chancros y muerte de ramas en níspero. Page 329 in: Resúmenes, XVI Congreso de la Sociedad Española de Fitopatología, SEF, Málaga, Spain.

- González-Domínguez E, Armengol J, García-Jiménez J, Soler E, 2013a. El moteado del níspero en la Marina Baixa. *Phytoma* 247, 50-52.
- González-Domínguez E, Rossi V, Armengol J, García-Jiménez J, 2013b. Effect of environmental factors on mycelial growth and conidial germination of *Fusicladium eriobotryae*, and the infection of loquat leaves. *Plant Disease* 97, 1331-1338
- González-Domínguez E, Armengol J, Rossi V, 2014a. Development and validation of a weather-based model for predicting infection of loquat fruit by *Fusicladium eriobotryae*. Submitted to *PLoS ONE*.
- González-Domínguez E, Martins RB, Ponte EM, Michereff SJ, García-Jiménez J, Armengol J, 2014b. Development and validation of a standard area diagram set to aid assessment of severity of loquat scab on fruit. *European Journal of Plant Pathology*. In press
- González-Domínguez E, Rodríguez-Reina JM, García-Jiménez J, Armengol J, 2014c. Evaluation of fungicides to control loquat scab caused by *Fusicladium eriobotryae* *Plant Health Management*. Accepted.
- González-Domínguez E, Rossi V, Michereff SJ, García-Jiménez J, Armengol J, 2014d. Spore dispersal and spatial patterns of *Fusicladium eriobotryae*, the causal agent of loquat scab. *European Journal of Plant Pathology*. In press.
- González-Lamothe R, Segura R, Trapero A, Baldoni L, Botella M, Valpuesta V, 2002. Phylogeny of the fungus *Spilocaea oleagina*, the causal agent of peacock leaf spot in olive. *FEMS Microbiology Letter* 210, 149-155.
- Gottwald TR, Bertrand PF, 1982. Patterns of diurnal and seasonal airborne spore concentration of *Fusicladium effusum* and its impact on a pecan scab epidemic. *Phytopathology* 72, 330-335.
- Gottwald TR, 1983. Factors affecting spore liberation by *Cladosporium carpophilum*. *Phytopathology*, 73, 1500-1505.
- Gottwald TR, 1985. Influence of temperature, leaf wetness period, leaf age, and spore concentration on infection of pecan leaves by conidia of *Cladosporium caryigenum*. *Phytopathology* 75, 190-194.
- Graniti A, 1990. Plant diseases in the Mediterranean region. *Phytoparasitica* 18, 57-65.
- Gu H, Liu AY, Chen WX, Feng SJ, Shi JY, 2007. Development and control of postharvest diseases of loquat fruit. *Acta Horticulturae* 750, 437-443.

- GVA, 2013. *Butlletí d'Avisos, Octubre-Noviembre*. Generalitat Valenciana, Conselleria d'Agricultura, Pesca i Alimentació, València, Spain.
- Hanley JA, 2005. Receiver operating characteristic (ROC) curves. In: Armitage P, Colton T, (Eds.). *Encyclopedia of Biostatistics*, John Wiley and Sons, New York, NY, USA. 6100 pp.
- Hartman JRR, Parisi L, Bautreais P, 1999. Effect of leaf wetness duration, temperature, and conidial inoculum dose on apple scab infections. *Plant Disease* 83, 531-534.
- Henríquez JL, Sarmiento O, Alarcón P, 2011. Sensitivity of *Venturia inaequalis* Chilean isolates to difenoconazole, fenarimol, mancozeb and pyrimethanil. *Chilean Journal of Agricultural Research* 71, 39-44.
- Hewitt HG, 1998. *Fungicides in Crop Protection*. CAB International, Wallingford, UK, 221 pp.
- Hibbett DS, Taylor JW, 2013. Fungal systematics, is a new age of enlightenment at hand? *Nature reviews. Microbiology* 11, 129-133.
- Hirst JM, Stedman J, 1961. The epidemiology of apple scab (*Venturia inaequalis* (Cke) Wint). *Annals of Applied Biology* 49, 290-305.
- Holb IJ, De Jong P, Heijne B, 2003. Efficacy and phytotoxicity of lime sulphur in organic apple production. *Annals of Applied Biology* 142, 225-233.
- Holb IJ, Heijne B, Withagen JCM, Jeger MJ, 2004. Dispersal of *Venturia inaequalis* ascospores and disease gradients from a defined inoculum source. *Journal of Phytopathology* 152, 639-646.
- Holtslag QA, Remphrey WR, Fernando WGD, Ash GHB, 2004. The development of a dynamic disease-forecasting model to control *Entomosporium mespili* on *Amelanchier alnifolia*. *Canadian Journal of Plant Pathology* 313, 304-313.
- Horsfall JG, Cowling EB, 1978. Pathometry, the measurement of plant disease In: Horsfall JG, Cowling EB, (Eds). *Plant disease, an advanced treatise*, Vol II Academic Press, New York, NY, USA, pp 20-136.
- Horsfield A, Wicks T, Wilson D, 2010. Field evaluation of fungicides for the control of rust, brown rot, shot hole and scab in almonds. *Australasian Plant Pathology* 39, 112-119.
- Hui C, 2006. Carrying capacity, population equilibrium, and environment's maximal load. *Ecological Modelling* 192, 317-320.
- Hurtado-Gonzales OP, Aragon-Caballero LM, Flores-Torres JG, Veld WMIT, Lamour KH, 2009. Molecular comparison of natural hybrids of

- Phytophthora nicotianae* and *P. cactorum* infecting loquat trees in Peru and Taiwan. *Mycologia* 101, 496-502.
- Istat, 2014. *Agricultural Census at a Glance*. Istituto nazionale di statistica. <http://censimentoagricoltura.istat.it/inbreve/?lang=en>.
- IVIA, 2012. *Instituto Valenciano de Investigaciones Agrarias*. <http://riegos.ivia.es/>
- Jackson SL, Bayliss KL, 2011. Spore traps need improvement to fulfil plant biosecurity requirements. *Plant Pathology*, 60, 801-810.
- Jamar L, Pahaut B, Lateur M, 2010. A low input strategy for scab control in organic apple production. *Acta Horticulturae* 4, 75-84.
- James WC, 1971. An illustrated series of assessment keys for plant diseases, their preparation and usage. *Canadian Plant Disease Survey* 51, 39-65.
- James JR, Sutton TB, 1982. Environmental factors influencing pseudothecial development and ascospore maturation of *Venturia inaequalis*. *Phytopathology* 72,1073-1080.
- Janick J, 2011. Predictions for loquat improvement in the next decade. *Acta Horticulturae* 887, 25-30.
- Jones AL, Walker RJ, 1976. Tolerance of *Venturia inaequalis* to dodine and benzimidazole fungicides in Michigan. *Plant Disease Reports* 60, 40-44.
- Kiely TB, 1948. Preliminary studies on *Guignardia citricarpa*, the ascigerous stage of *Phoma citricarpa* and its relation to black spot of citrus. *Proceedings of the Linnean Society of New South Wales*, 73, 249-292.
- Klosowski AC, Ruaro L, Bessalho Filho JC, May De Mio LL, 2013. Proposal and validation of diagrammatic scale for assessment of orange rust of sugarcane. *Tropical Plant Pathology* 38, 166-171.
- Koch PL, Grau CR, Jo Y-K, Jung G, 2009. Thiophanate-methyl and propiconazole sensitivity in *Sclerotinia homoeocarpa* populations from golf courses in Wisconsin and Massachusetts. *Plant Disease* 93, 100-105.
- Koenraadt H, Somerville S, Jones AL, Jones AL, 1992. Characterization of mutations in the beta-tubulin gene of benomyl-resistant field strains of *Venturia inaequalis* and other plant pathogenic fungi. *Phytopathology* 82, 1348-1354.
- Koh HS, Sohn SH, Lee YS, Koh YJ, Song JH, Jung JS, 2013. Specific and sensitive detection of *Venturia nashicola*, the scab fungus of Asian pears, by nested PCR. *Plant Pathology Journal* 29, 357-363.

- Kottek M, Grieser J, Beck C, Rudolf B, Rubel F, 2006. World map of the Köppen-Geiger climate classification updated. *Meteorologische Zeitschrift* 15, 259-263.
- Kotzé JM, 1981. Epidemiology and control of citrus black spot in South Africa. *Plant Disease* 65, 945-950.
- Kranz J, 1988. Measuring plant disease. In: *Experimental Techniques in Plant Disease Epidemiology* J Kranz, J Rotem (Eds), Springer-Verlag, New York, NY, USA, pp 35-50.
- Krause RA, Massie LB, 1975. Predictive systems, modern approaches to disease control. *Annual Review of Phytopathology* 13, 31-47.
- Kuck K-H, 2005. Fungicide resistance management in a new regulatory environment. In: Dehne HW, Gisi U, Kuck KH, Russell PE, Lyr H (eds). *Modern fungicides and anti-fungal compounds IV* BCPC, Alton UK, pp. 35-43.
- Lai M, McCartney O, Morin C, 1971. Canker of loquat caused by *Pseudomonas* sp. *Phytopathology* 61, 248-249.
- Lamari L, 2008. *ASSESS 20, Image Analysis Software for Plant Disease Quantification*. APS Press StPaul, MN, USA.
- Lan Z, Scherm H, 2003. Moisture sources in relation to conidial dissemination and infection by *Cladosporium carpophilum* within peach canopies. *Phytopathology* 93, 1581-1586.
- Latham AJ. 1982. Effect of some weather factors and *Fusicladium effusum* conidium dispersal on pecan scab occurrence. *Phytopathology* 72, 1339-1345.
- Lawrence E, Zehr E, 1982. Environmental effects on the development and dissemination of *Cladosporium carpophilum* on peach. *Phytopathology* 72, 773-776.
- Le Cam B, Parisi L, Arene L, 2002. Evidence of two formae speciales in *Venturia inaequalis*, responsible for apple and pyracantha scab. *Phytopathology* 92, 314-320.
- Leffelaar P, 1993. *On systems analysis and simulation of ecological processes*. Kluwer Academic Publishers, Dordrecht, the Netherlands, 319 pp.
- Legler SE, Caffi T, Rossi V, 2013. A Model for the development of *Erysiphe necator* chasmothecia in vineyards. *Plant Pathology*, In press.

- Leite RMVBC, Amorim L, 2002. Elaboração e validação de escala diagramática para mancha de *Alternaria* em girassol. *Summa Phytopathologica* 28, 14-19.
- Leroux P, Walker AS, 2011. Multiple mechanisms account for resistance to sterol 14 α -demethylation inhibitors in field isolates of *Mycosphaerella graminicola*. *Pest Management Science* 67, 44-59.
- Li B, Zhao H, Xu XM, 2003. Effects of temperature, relative humidity and duration of wetness period on germination and infection by conidia of the pear scab pathogen (*Venturia nashicola*). *Plant Pathology* 52, 546-552.
- Li BH, Xu XM, Li JT, Li BD, 2005. Effects of temperature and continuous and interrupted wetness on the infection of pear leaves by conidia of *Venturia nashicola*. *Plant Pathology* 54, 357-363.
- Li B, Yang J, Dong X, Li B, Xu X, 2007. A dynamic model forecasting infection of pear leaves by conidia of *Venturia nashicola* and its evaluation in unsprayed orchards. *European Journal of Plant Pathology* 118, 227-238.
- Lian S, Li BD, Dong XL, Xu XM, 2007. Effects of environmental factors on discharge and germination of ascospores of *Venturia nashicola*. *Plant Pathology* 56, 402-411.
- Lima GSA, Assunção IP, Martins RB, Santos HV, Michereff SJ, 2011. Development and validation of a standard area diagram set for assessment of *Alternaria* spot on the cladodes of the prickly pear cactus. *Journal of Plant Pathology* 93, 691-695.
- Lin L, 1989. A concordance correlation coefficient to evaluate reproducibility. *Biometrics* 45, 255-268.
- Lin S, Sharpe RH, Janick J, 1999. Loquat: botany and horticulture. In: Jules J (Eds.). *Horticultural Reviews*, vol 23 Wiley, New York, NY, USA, pp 234-276.
- Lin SQ, 2007. World loquat production and research with special reference to China. *Acta Horticulturae* 750, 37-44.
- Liu AY, Chen WX, Gu H, Shi JY, Li J, 2007. Biological characteristic of pathogenic fungus causing anthracnose of loquat fruit. *Acta Horticulturae* 750, 465-470.
- Liu Y, Chen X, Jiang J, Hamada MS, Yin Y, Ma Z, 2013. Detection and dynamics of different carbendazim-resistance conferring β -tubulin variants of *Gibberella zeae* collected from infected wheat heads and rice stubble in China. *Pest Management Science*, In press.

- Llorente I, Vilardell P, Gherardi I, Montesinos E, 2000. Evaluation of BSPcast disease warning system in reduced fungicide use programs for management of brown spot of pear. *Plant Disease* 84, 631–637.
- López-Ruiz FJ, Pérez-García A, Fernández-Ortuño D, Romero D, García E, de Vicente A, Brown JKM, Torés JA, 2010. Sensitivities to DMI fungicides in populations of *Podosphaera fusca* in south central Spain. *Pest Management Science* 66, 801-808.
- Lops F, Frisullo S, Rossi V, 1993. Studies on the spread of the olive scab pathogen, *Spilocaea oleagina*. *EPPO Bulletin* 23, 385-387.
- Luo Y, Michailides TJ, 2001. Risk analysis for latent infection of prune by *Monilinia fructicola* in California. *Phytopathology* 91, 1197-1208.
- Ma Z, Felts D, Michailides TJ, 2003. Resistance to azoxystrobin in *Alternaria* isolates from pistachio in California. *Pesticide Biochemistry Physiology* 77, 66-74.
- Ma Z, Michailides TJ, 2005. Advances in understanding molecular mechanisms of fungicide resistance and molecular detection of resistant genotypes in phytopathogenic fungi. *Crop Protection* 24, 853-863.
- Ma Z, Yoshimura M, Holtz B, Michailides TJ, 2005. Characterization and PCR-based detection of benzimidazole-resistant isolates of *Monilinia laxa* in California. *Pest Management Science* 61, 449-457.
- Ma B, Tredway LP, 2013. Induced overexpression of cytochrome P450 sterol 14 α -demethylase gene (CYP51) correlates with sensitivity to demethylation inhibitors (DMIs) in *Sclerotinia homoeocarpa*. *Pest Management Science* 69, 1369–1378.
- MacHardy WE, Gadoury DM, 1989. A revisions of Mills's criteria for predicting apple scab infection periods. *Phytopathology* 79, 304-310.
- MacHardy WE, 1996. *Apple scab: biology, epidemiology, and management*. St Paul APS Press, MN, USA, 545 pp.
- Madden LV, 1992. Rainfall and the dispersal of fungal spores. *Advances in Plant Pathology* 8, 39-79.
- Madden LV, 2006. Botanical epidemiology: some key advances and its continuing role in disease management. *European Journal of Plant Pathology*, 115, 3-23.
- Madden L, Hughes G, van den Bosch F, 2007. *The study of plant disease epidemics*. Paul APS Press, MN, USA, 421 pp.

- MAGRAMA, 2013. *Anuario de estadística 2012*. Ed Ministerio de Agricultura, Alimentación y Medio Ambiente. Madrid 891 pp.
- MAGRAMA, 2014. *Registro de productos fitosanitarios*. Ministerio de Agricultura, Alimentación y Medio Ambiente <http://www.magramagobes.es/agricultura/temas/sanidad-vegetal/productos-fitosanitarios/fitosasp>.
- Manulis S, Kleitman F, Dror O, David I, Zutra D, 1998. Characterization of the *Erwinia amylovora* population in Israel. *Phytoparasitica* 26, 39-46.
- Martín L, Martín MT, 2013. Characterization of fungicide resistant isolates of *Phaeoacremonium aleophilum* infecting grapevines in Spain. *Crop Protection* 52, 141-150.
- Martínez-Calvo BJ, Badenes ML, Llacer G, Bleiholder H, Hack H, Meier U, 1999. Phenological growth stages of loquat tree (*Eriobotrya japonica* (Thunb) Lindl.). *Annals of applied Biology* 134, 353-357.
- Martínez-Calvo J, Gisbert AD, Alamar MC, Hernandorena R, Romero C, Llácer G, Badenes ML, 2007. Study of a germplasm collection of loquat (*Eriobotrya japonica* Lindl.) by multivariate analysis. *Genetic Resources and Crop Evolution* 55, 695-703.
- McRae EM, Hale CN, 1986. New plant disease record in New Zealand: loquat canker. *New Zealand Journal of Agricultural Research* 29, 547-550.
- Menon R, 1956. Studies on Venturiaceae on rosaceous plants. *Phytopathologische Zeitschrift* 27, 117-146.
- Meredith DS, 1973. Significance of spore release and dispersal mechanisms in plant disease epidemiology. *Annual Review of Phytopathology* 11, 313-342.
- Michereff SJ, Pedrosa RA, Noronha MA, Martins RB, Silva FV, 1998. Escala diagramática e tamanho de amostras para avaliação da severidade da mancha parda da mandioca (*Cercosporidium henningsii*). *Agrotrópica* 3, 143-148.
- Michereff SJ, Maffia LA, Noronha MA, 2000. Diagrammatic key for assessment of yam leaf blight severity. *Fitopatologia Brasileira* 25, 612-619 (in Portuguese).
- Michereff SJ, Noronha MA, Lima GSA, Albert ICL, Melo EA, Gusmão LO, 2009. Diagrammatic scale to assess downy mildew severity in melon. *Horticultura Brasileira* 27, 76-79.
- Miller PA, 1942. *Phytophthora* crown rot of loquat. *Phytopathology* 32, 404-409.

- Mills WD, Laplante AA, 1954. Diseases and insects in the orchard. *Cornell Extension Bullentin*, 711.
- Mio LLM, Luo Y, Michailides TJ, 2011. Sensitivity of *Monilinia fructicola* from brazil to tebuconazole, azoxystrobin, and thiophanate-methyl and implications for disease management. *Plant Disease* 95, 821-827.
- Mondal SN, Vicent A, Reis RF, Timmer LW, 2007. Efficacy of pre- and postinoculation application of fungicides to expanding young citrus leaves for control of melanose, scab, and *Alternaria* brown spot. *Plant Disease* 91, 1600-1606.
- Morita A, 2001. Studies on physiology and ecology of loquat canker. *Journal of Genetics Plant Pathology* 67, 244-247.
- Mwakutuya E, Banniza S, 2010. Influence of temperature and wetness periods on the development of *Stemphylium* blight on lentil. *Plant Disease* 94, 1219-1224.
- Nash JE, Sutcliffe JV, 1970. River flow forecasting through conceptual models. part I: A discussion of principles. *Journal of Hydrology* 10, 282-290.
- Nita M, Ellis MA, Madden LV, 2003. Reliability and accuracy of visual estimation of *Phomopsis* leaf blight of strawberry. *Phytopathology* 93, 995-1005.
- O'Donnell K, Cigelnik E, 1997. Two divergent intragenomic rDNA ITS2 types within a monophyletic lineage of the fungus *Fusarium* are nonorthologous. *Molecular Phylogenetics Evolution* 7, 103-116.
- Obanor FO, Walter M, Jones EE, Jaspers MV, 2005. *In vitro* effects of fungicides on conidium germination of *Spilocaea oleagina*, the cause of olive leaf spot. *New Zealand Plant Protection* 58, 278-282.
- Obanor FO, Jaspers MV, Jones E, Walter M, 2008a. Greenhouse and field evaluation of fungicides for control of olive leaf spot in New Zealand. *Crop Protection* 27, 1335-1342.
- Obanor FO, Walter M, Jones EE, Jaspers MV, 2008b. Effect of temperature, relative humidity, leaf wetness and leaf age on *Spilocaea oleagina* conidium germination on olive leaves. *European Journal of Plant Pathology* 120, 211-222.
- Obanor FO, Walter M, Jones EE, Jaspers MV, 2010. Effects of temperature, inoculum concentration, leaf age, and continuous and interrupted wetness on infection of olive plants by *Spilocaea oleagina*. *Plant Pathology* 60, 190-199.
- ODEPA, 2014. Oficina de estudios y políticas agrarias. Ministerio de agricultura, Gobierno de Chile. <http://www.odepa.cl/superficie-de-frutales-por-region-2/>.

- Ogawa JM, English H, 1991. *Diseases of Temperate Zone Tree Fruit and Nut Crops*. University of California, California, 461 pp.
- Ooka JJ, Kommnedahl T, 1977. Wind and rain dispersal of *Fusarium moniliforme* in corn fields. *Phytopathology* 67, 1023-1026.
- Palma MA, Merello C, San Martín J, 2006. Determinación de *Botryosphaeria obtusa* (Schwein) Shoemaker/ *Diplodia pinea* complex ocasionando cancrrosis en níspero (*Eriobotrya japonica* L.) en Quillota, V Región de Chile. In: *Resúmenes XVI Congreso Sociedad Chilena de Fitopatología* 14-17 Noviembre de 2006 La Serena, Chile.
- Palou L, Montesinos-Herrero C, Guardado A, Taberner V, 2013a. First report of *Pestalotiopsis clavispora* causing postharvest fruit rot of loquat in Spain. *Journal of Plant Pathology* 95, 469.
- Palou L, Taberner V, Montesinos-Herrero C, 2013b. First report of *Diplodia seriata* causing loquat fruit rot in Spain. *Plant Disease* 97, 421-422.
- Payne AF, Smith DL, 2012. Development and evaluation of two pecan scab prediction models. *Plant Disease* 96, 1358-1364.
- Pedroso C, Lage DAC, Henz GP, Café-Filho AC, 2011. Development and validation of a diagrammatic scale for estimation of anthracnose on sweet pepper fruits for epidemiological studies. *Journal of Plant Pathology* 93, 219-225.
- Perelló AE, Larran S, 1999. First report of *Pestalotiopsis guepini* on loquat in Argentina. *Plant Disease* 83, 695.
- Pfeufer EE, Ngugi HK, 2012. Orchard factors associated with resistance and cross resistance to sterol demethylation inhibitor fungicides in populations of *Venturia inaequalis* from Pennsylvania. *Phytopathology* 102, 272-282.
- Prota U, 1960. Ricerche sulla « ticchiolatura del Nespolo del Giappone e sul suo agente (*Fusicladium eriobotryae* Cav). I: Osservazioni sull'epidemiologia della malattia e sui caratteri morfo-biologici del parassita in Sardegna. *Stud di Sassari, Sez III* 8, 175-196.
- Ptskialadze LI, 1968. The causal agent of loquat scab and its biological characteristics. *Review of applied mycology* 47, 268.
- Quello KL, Chapman KS, Beckerman JL, Lafayette W, 2010. In situ detection of benzimidazole resistance in field isolates of *Venturia inaequalis* in Indiana. *Plant Disease* 94, 744-750.

- R Core Team, 2013. *R, A Language, Environment for Statistical Computing*. R Foundation for Statistical Computing, Vienna, Austria. <http://www.R-project.org/>.
- Raabe R, Gardner MW, 1972. Scab of pyracantha, loquat, toyon and kageneckia. *Phytopathology* 62, 914-916.
- Raposo R, Delcan J, Gomez V, Melgarejo P, 1996. Distribution and fitness of isolates of *Botrytis cinerea* with multiple fungicide resistance in Spanish greenhouses. *Plant Pathology* 45, 497-505.
- Reig C, Mesejo C, Martínez-Fuentes A, Iglesias DJ, and Agustí M, 2012. Fruit load and root development in field-grown loquat trees (*Eriobotrya japonica* Lindl.) *Journal of Plant Growth Regulation*, In press.
- Rodríguez A, 1983. *El cultivo del níspero en el valle del Algar-Guadalest*. Sociedad Cooperativa de Crédito de Callosa d'En Sarrià, Callosa d'En Sarrià, Alicante, España, 262 pp.
- Rossi V, Giosue S, Bugiani R, 2003. Influence of air temperature on the release of ascospores of *Venturia inaequalis*. *Journal of Phytopathology* 151, 50-58.
- Rossi V, Caffi T, Giosuè S, Girometta B, Bugiani R, Dellavalle D, Brunelli A, Collina M, 2005. Elaboration and validation of a dynamic model for primary infections of *Plasmopara viticola* in North Italy. *Rivista Italiana di Agrometeorologia* 13, 7-13.
- Rossi V, Bugiani R, 2007. A-scab (Apple-scab), a simulation model for estimating risk of *Venturia inaequalis* primary infections. *EPPO Bulletin* 37, 300-308.
- Rossi V, Salinari F, Patteri E, Giosuè S, Bugiani R, 2009. Predicting the dynamics of ascospore maturation of *Venturia pirina* based on environmental factors. *Phytopathology* 99, 453-461.
- Rossi V, Giosuè S, Caffi T, 2010. Modelling plant diseases for decision making in crop protection. In: Oerke EC, Gerhards R, Menz G, Sikora RA (eds.). *Precision Crop Protection-the Challenge and Use of Heterogeneity*. Springer, Dordrecht, Netherlands, pp241-258.
- Rossi V, Caffi T, Salinari F, 2012. Helping farmers face the increasing complexity of decision-making for crop protection. *Phytopathologia Mediterranea* 51, 457-479.
- Roubal C, Regis S, Nicot PC, 2013. Field models for the prediction of leaf infection and latent period of *Fusicladium oleagineum* on olive based on rain, temperature and relative humidity. *Plant Pathology* 62, 657-666.

- Russell PE, 2004. *Sensitivity baselines in fungicide resistance research and management*. FRAC Monograph N° 3. Fungicide Resistance Action Committee, Brussels, Belgium, 56 pp.
- Saad A, 1959. *Fungicidal control of Fusicladium eriobotryae (Cav) Sacc*. Thesis (MS)-School of Agriculture, American University of Beirut. 60 pp.
- Sachs PJD, Neves CCSVJ, Canteri MG, Sachs LG, 2011. Diagrammatic scale for assessment of the Phaeosphaeria leaf spot severity in maize. *Summa Phytopathologica* 37, 202-204.
- Salerno M, Somma V, Rosciglione B, 1971a. Ricerche sull'epidemiologia della ticchiolatura del nespolo del giappone. *Tecnica Agricola* 23, 947-956.
- Salerno M, Somma V, Rosciglione B, 1971b. Confronto di fungicidi nella lotta contro la ticchiolatura del nespolo del giappone. *Tecnica Agricola* 26, 947-956.
- Sanchez-Torres P, Hinarejos R, Tuset JJ, 2007a. *Fusicladium eriobotryae*, hongo causante del moteado del níspero en el mediterráneo español. *Boletín de Sanidad Vegetal Plagas* 33, 87-98.
- Sánchez-Torres P, Hinarejos R, Tuset JJ, 2007b. Identification and characterization of *Fusicladium eriobotryae*, fungal pathogen causing Mediterranean loquat scab. *Acta Horticulturae* 750, 343-348.
- Sánchez-Torres P, Hinarejos R, Tuset JJ, 2009. Characterization and pathogenicity of *Fusicladium eriobotryae*, the fungal pathogen responsible for loquat scab. *Plant Disease* 93, 1151-1157.
- Santos WF, Alves MC, Carvalho LG, Rios GFA, Fraga AC, 2010. Elaboration and validation of a diagrammatic scale for epidemiological studies of cercospora leaf spot of castor bean. *Journal of Phytopathology* 158, 403-408.
- Scherm H, Savelle AT, Boozer RT, Foshee WG, 2008. Seasonal dynamics of conidial production potential of *Fusicladium carpophilum* on twig lesions in southeastern peach orchards. *Plant Disease* 92, 47-50.
- Schnabel G, Jones AL, 2000. The 14 α -Demethylase (CYP51A1) gene is overexpressed in *Venturia inaequalis* strains resistant to myclobutanil. *Phytopathology* 91, 102-110.
- Schoch CL, Sung GH, López-Giráldez F, Townsend JP, Miadlikowska J, Hofstetter V, Robbertse B, Matheny PB, Kauff F, Wang Z, Gueidan C, Andrieu RM, Trippe K, Ciuffetti LM, Wynns A, Fraker E, Hodkinson BP, Bonito G, Groenewald JZ, Arzanlou M, de Hoog GS, Crous PW, Hewitt D, Pfister DH, Peterson K, Gryzenhout M, Wingfield MJ, Aptroot A, Suh SO, Blackwell M, Hillis DM, Griffith GW, Castlebury LA, Rossman AY, Lumbsch HT,

- Lücking R, Büdel B, Rauhut A, Diederich P, Ertz D, Geiser DM, Hosaka K, Inderbitzin P, Kohlmeyer J, Volkmann-Kohlmeyer B, Mostert L, O'Donnell K, Sipman H, Rogers JD, Shoemaker RA, Sugiyama J, Summerbell RC, Untereiner W, Johnston PR, Stenroos S, Zuccaro A, Dyer PS, Crittenden PD, Cole MS, Hansen K, Trappe JM, Yahr R, Lutzoni F, Spatafora JW, 2009. The ascomycota tree of life : a phylum-wide phylogeny clarifies the origin and evolution of fundamental reproductive and ecological traits. *Systematic Biology* 58, 224-239.
- Schubert K, Ritschel A, Braun U, 2003. A monograph of *Fusicladium* s.lat. (Hyphomycetes). *Schlechtendalia* 9, 1-132.
- Schut M, Rodenburg J, Klerkx L, van Ast A, Bastiaans L, 2014. Systems approaches to innovation in crop protection: A systematic literature review. *Crop Protection* 56, 98-108.
- Schwabe WFS, Jones AL, Jonker JP, 1984. Greenhouse evaluation of the curative and protective action of sterol-inhibiting fungicides against apple scab. *Phytopathology* 74, 249-252.
- Seo S, Park M, Shin H, Kim K, 2011. Occurrence of leaf spot on *Eriobotrya japonica* caused by *Entomosporium mespili* in Korea. *Research in Plant Disease* 17, 228-231.
- Sherwood RT, Berg CC, Hoover MR, Zeiders KE, 1983. Illusions in visual assessment of *Stagonospora* leaf spot of orchardgrass. *Phytopathology* 73, 173-177.
- Shih JC, 2007. Loquat production in Taiwan. *Acta Horticulturae* 750, 55-59.
- Shrout PE, Fleiss JL, 1979. Intraclass correlations, uses in assessing rater reliability. *Psychological Bulletin* 86, 420-428.
- Shtienberg D, 2013. Will decision-support systems be widely used for the management of plant diseases?. *Annual Review of Phytopathology* 51, 1-16.
- Sivanesan A, 1977. *The taxonomy and pathology of Venturia species*. Bibliotheca Mycologica, J Cramer, Vaduz, Liechtenstein. 140pp.
- Soler E, Martínez-Calvo J, Llácer G, Badenes ML, 2007. Loquat in Spain, production and market. *Acta Horticulturae* 750, 45-47.
- Soriano JM, Romero C, Vilanova S, Llácer G, 2005. Genetic diversity of loquat germplasm (*Eriobotrya japonica* (Thunb) Lindl.) assessed by SSR markers. *Genome* 48, 108-114.
- Spolti P, Schneider L, Sanhueza RMV, Batzer JC, Gleason ML, Del Ponte EM, 2011. Improving sooty blotch and flyspeck severity estimation on apple

- fruit with the aid of standard area diagrams. *European Journal of Plant Pathology* 129, 21-29.
- Spósito MB, Amorim L, Belasque J, Bassanezi RB, Aquino R, 2004. Elaboração e validação de escala diagramática para avaliação da severidade da mancha preta em frutos cítricos. *Fitopatologia Brasileira* 29,81-85.
- Spósito MB, Amorim L, Bassanezi RB, Filho AB, Hau B, 2008. Spatial pattern of black spot incidence within citrus trees related to disease severity and pathogen dispersal. *Plant Pathology* 57, 103-108.
- Spotts RA, Cervantes A, 1991. Effect of temperature and wetness on infection of pear by *Venturia pirina* and the relationship between preharvest inoculation and storage scab. *Plant Disease* 75, 1204-1207.
- Spotts RA, Cervantes A, Cervantes LA, 1994. Factors affecting maturation and release of ascospores of *Venturia pirina* in Oregon. *Phytopathology* 84, 260-264.
- Stehmann C, Pennycook S, Plummer KM, 2001. Molecular identification of a sexual interloper, the pear pathogen, *Venturia pirina*, has sex on apple. *Phytopathology* 91, 633-641.
- Stensvand A, Gadoury DM, Amundsen T, Semb L, Seem RC, 1997. Ascospore release and infection of apple leaves by conidia and ascospores of *Venturia inaequalis* at low temperatures. *Phytopathology* 87, 1046-1053.
- Stevenson M, 2012. *EpiR, An R Package for the Analysis of Epidemiological Data* R package version 09-43. <http://CRAN.R-project.org/package=epiR>.
- Suga H, Nakajima T, Kageyama K, Hyakumachi M, 2011. The genetic profile and molecular diagnosis of thiophanate-methyl resistant strains of *Fusarium asiaticum* in Japan. *Fungal Biology* 115, 1244-1250.
- Sutton TB, Jones AL, Nelson LA, 1976. Factors affecting dispersal of conidia of the apple scab fungus. *Phytopathology* 66, 1313-1317.
- Tamura K, Peterson D, Peterson N, Stecher G, Nei M, Kumar S, 2011. MEGA5, molecular evolutionary genetics analysis using maximum likelihood, evolutionary distance, and maximum parsimony methods. *Molecular Biology Evolutions* 28, 2731-2739.
- Taylor JW, Jacobson DJ, Kroken S, Kasuga T, Geiser DM, Hibbett DS, Fisher MC, 2000. Phylogenetic species recognition and species concepts in fungi. *Fungal Genetics Biology* 31, 21-32.
- Teng PS, 1981. Validation of computer models of plant disease epidemics, a review of philosophy and methodology. *Journal of Plant Disease and Protection* 88, 63-49.

- Thomas CS, Gubler WD, Leavitt G, 1994. Field testing of a powdery mildew disease forecast model on grapes in California. *Phytopathology* 84, 1070.
- Thomas A, Langston DB, Stevenson KL, 2012. Baseline sensitivity and cross-resistance to succinate-dehydrogenase-inhibiting and demethylation-inhibiting fungicides in *Didymella bryoniae*. *Plant Disease* 96, 979-984.
- Townsend CR, Begon M, Harper JL, 2008. *Essentials of ecology*. Wiley, New York, NY, USA, 510 pp.
- Trapman M, Polfliet CM, 1997. Management of primary infections of apple scab with the simulation program RIMpro: review of four years field trials. *IOBC Bulletin* 20, 241-250.
- Trkulja N, Ivanović Ž, Pfaf-Dolovac E, Dolovac N, Mitrović M, Toševski I, Jović J, 2012. Characterisation of benzimidazole resistance of *Cercospora beticola* in Serbia using PCR-based detection of resistance-associated mutations of the β -tubulin gene. *European Journal of Plant Pathology* 135, 889-902.
- Turechek WW, Wilcox WF, 2005. Evaluating predictors of apple scab with receiver operating characteristic curve analysis. *Phytopathology* 95, 679-691.
- Umemoto S, 1990. Dispersion of ascospores and conidia of causal fungus of Japanese pear scab, *Venturia nashicola*. *Annals Phytopathology Japan Society* 56, 468-473.
- Villalta O, Washington WS, Rimmington GM, Taylor PA, 2000a. Influence of spore dose and interrupted wet periods on the development of pear scab caused by *Venturia pyrina* on pear (*Pyrus communis*) seedlings. *Australasian Plant Pathology* 29, 255-262.
- Villalta O, Washington WS, Rimmington GM, Taylor PA, 2000b. Effects of temperature and leaf wetness duration on infection of pear leaves by *Venturia pyrina*. *Australasian Journal of Agricultural Research* 51, 97-106.
- Viruega JR, Roca LF, Moral J, Trapero A, 2011. Factors affecting infection and disease development on olive leaves inoculated with *Fusicladium oleagineum*. *Plant Disease* 95, 1139-1146.
- Viruega JR, Moral J, Roca LF, Navarro N, Trapero A, 2013. *Spilocaea oleagina* in olive groves of southern Spain: survival, inoculum production, and dispersal. *Plant Disease* 97, 1549-1556.
- Waggoner PE, Rich S, 1981. Lesion distribution, multiple infection, and the logistic increase of plant disease. *Proceedings of the National Academy of Sciences of USA* 78, 3292-3295.

- Wang L, Wang HC, Hu YL, Huang XM, 2007. Loquat fruit physiological disorders, creasing and russetting. *Acta Horticulturae* 750, 269-273.
- White TJ, Burns T, Lee S, Taylor JW, 1990. Amplification and direct sequencing of fungal ribosomal RNA genes for phylogenetic. In: MA Innis, DH Gelfand, JJ Sninsky, and TJ White (Eds), *PCR protocols, a guide to methods and applications* (pp 315-322) San Diego, Academic Press.
- Wicks T, 1974. Tolerance of the apple scab fungus to benzimidazole fungicides. *Plant Disease Reports* 58, 886-889.
- Womach J, 2005. *Agriculture, a glossary of terms CRS report for congress*. 285 pp.
- Xu X, Butt DJ, Santen VAN, 1995. A dynamic model simulating infection of apple leaves by *Venturia inaequalis*. *Plant Pathology* 44, 865-876.
- Yadav NVS, de Vos SM, Bock CH, Wood BW, 2013. Development and validation of standard area diagrams to aid assessment of pecan scab symptoms on fruit. *Plant Pathology* 62, 325-335.
- Yuen JE, Hughes G, 2002. Bayesian analysis of plant disease prediction. *Plant Pathology* 51, 407-412.
- Yun Y, Yu F, Wang N, Chen H, Yin Y, Ma Z, 2012. Sensitivity to silthiofam, tebuconazole and difenoconazole of *Gaeumannomyces graminis* var. *tritici* isolates from China. *Pest Management Science* 68, 1156-1163.
- Zadoks JC, Schein RD, 1979. *Epidemiology and plant disease management*. Oxford University Press, New York 427 pp.
- Zhang Y, Crous PW, Schoch CL, Bahkali AH, Guo LD, Hyde KD, 2011. A molecular, morphological and ecological re-appraisal of Venturiales- a new order of Dothideomycetes. *Fungal Diversity* 51, 249-277.
- Zhao GJ, Yang ZQ, Chen XP, Guo YH, 2011. Genetic relationships among loquat cultivars and some wild species of the genus *Eriobotrya* based on the internal transcribed spacer (ITS) sequences. *Scientia Horticulturae* 130, 913-918.
- Zilberstaine M, Herzog Z, Manulis S, Zutra D, 1996. Outbreak of fire blight threatening the loquat industry in Israel. *Acta Horticulturae* 411, 177-178.
- Zweig MH, Campbell G, 1993. Receiver-operating characteristic (ROC) plots, a fundamental evaluation tool in clinical medicine. *Clinical Chemistry* 39, 561-577.