



CFD model of air movement in ventilated façade: comparison between natural and forced air flow

Miguel Mora Pérez, Gonzalo López Patiño, P. Amparo López Jiménez

Hydraulic and Environmental Engineering Department, Universitat Politècnica de Valencia, Spain.

Abstract

This study describes computational fluid dynamics (CFD) modeling of ventilated façade. Ventilated façades are normal façade but it has an extra channel between the concrete wall and the (double skin) façade. Several studies found in the literature are carried out with CFD simulations about the behavior of the thermodynamic phenomena of the double skin façades systems. These studies conclude that the presence of the air gap in the ventilated façade affects the temperature in the building skin, causing a cooling effect, at least in low-rise buildings. One of the most important factors affecting the thermal effects of ventilated façades is the wind velocity. In this contribution, a CFD analysis applied on two different velocity assumptions for air movement in the air gap of a ventilated façade is presented. A comparison is proposed considering natural wind induced velocity with forced fan induced velocity in the gap. Finally, comparing temperatures in the building skin, the differences between both solutions are described determining that, related to the considered boundary conditions, there is a maximum height in which the thermal effect of the induced flow is significantly observed.

Copyright © 2013 International Energy and Environment Foundation - All rights reserved.

Keywords: Ventilated Façade; Natural ventilation; Computational Fluid Dynamics (CFD); Architectural design; Wind energy.

1. Introduction

Nowadays new strategies in buildings are investigated by architects and engineers to improve the buildings energy performance. Designers commitment to green buildings should involve both, new sustainable buildings design and rehabilitation in the existing ones by installing new systems to make day to day operations more energy efficient and environmentally sensitive.

The envelope of a building is the main element responsible for its energy demand. The building skin ought to be a very susceptible part to be modified to improve the whole building energy performance. In this sense, the use of ventilated façades can often have a positive contribution to this objective. The implementation of ventilated façades in buildings has been an object of broad applications especially in recent years. Ventilated façades are a powerful tool when applied to building design, especially in bioclimatic building design. In some countries with high levels of solar radiation, summer over-heating is a big problem in building energy balances.

A ventilated façade is a double envelope composed of two skins and a ventilated cavity air gap located between them. Ventilated façade and wall coverings were developed to protect buildings against the combined action of rain and wind by counterbalancing the effects of water beating on walls and keeping the building dry, with high-level aesthetic characteristics and good heat insulation and soundproofing.

The ventilated façade consist of and external skin made of glass, marble, ceramic, etc. panels anchored in a sub-structure (generally made of aluminum profiles) to the external wall surface of the building. This first layer defines the visual appearance of the building. The next layer is an opened air gap with a minimum of 3 cm. The role of this layer is to prevent heat getting into the building in summer and take moisture out of the building. In this ventilated gap the aluminum substructure which supports the external layer must be properly installed in order to not avoid natural ventilation effect. Finally, the external buildings face, made of rigid and properly bonded thermal insulation material. This layer must resist tearing and dispersion of the material due to any stronger air flow in the ventilated layer.

The ventilated façade must achieve some basic requirements in both summer and winter conditions: air permeability to reduce heat dispersion in winter and guarantee passive cooling effect by combining convective and heat transport between the outer and inner walls in summer; watertight to guarantee no water infiltration due to rain, humidity and no condensation on the surface into the wall mass. Finally, thermal performance to guarantee the indoor thermal comfort is also important, as a good ventilated façade has many energy implications, Balocco [1].

As designer, building owners and architects look for solutions to fulfill the requirements of energy efficiency good practice. Alternatives as Computational Simulations should be provided to meet their short-term needs. Significant research has been carried out to provide methods for building designers to examine the energy implications of their design decisions. There are currently many different modeling approaches used in predicting building ventilation including analytical models, empirical models, multi-zone models, zonal models, experimental models and computational fluid dynamics (CFD) models [2]. The use of CFD in particular has risen since 2002. The wide applicability, acceptability of CFD as a ventilation modeling tool is however tied to its concurrent use with theoretical and experimental models as verification and validation of available codes become increasingly important [3].

These improvements are related with the ventilation capacity of the additional structure to the shield mainly for saving cooling power in summer in warm countries. It deals with natural ventilation. Natural ventilation can be explained by two phenomena: wind driven ventilation and buoyancy-driven ventilation. While wind is the main mechanism of wind driven ventilation, buoyancy-driven ventilation occurs as a result of the directional buoyancy force that results from temperature differences between the interior and exterior [4]. This effect is due to convection produced in the air gap of the façade, Kokogiannakis and Strachan [5]; Gang, [6]. This convection depends on the air movement inside the gap and the heat transmission in this motion, Manz [7]; Yilmaz [8].

Previous studies performed by Ciampi et al. [9] showed that one of the more affecting factors to increase the efficiency of the façade is the external air temperature. The presence of ventilated façade in a building leads to a cooling effect in the skin of this building due to the action of the air movement in the gap as demonstrated in many references. [10, 11]. In summer conditions the energy savings will increase remarkably as solar radiation increases: the bigger the solar radiation is, the more efficient ventilated façades turn to be from an energy point of view. The cooling capacity would be increased due to the convective effect of the air movement which will increase the speed of the air circulating inside the façade. This aspect has been also simulated with the current CFD analysis by López et al [10].

The principal objective of the ventilated façade is to provide the building with a double-skinned interface to reduce the impact of incident radiation on the indoor environment. The additional skin reduces the façade temperature in two ways: it shades the original façade and it reduces its temperature by natural ventilation flows. The proposed paper aims to quantify the action of accelerating the air flow in a forced way. The proposed method allows an assessment of the thermal potential of ventilated façade and its capacity for cooling. These quantities are mathematically modeled by CFD techniques. CFD is used to quantify and compare the effect of natural and forced ventilation in a building's façade.

2. Methodology

2.1 General objective

A system to improve the cooling capacity of ventilated façade is analyzed in this paper. The objective is the quantification of the improvement in the efficiency of thermal behavior of buildings when this sort of system is installed in a ventilated façade, especially in summer conditions. The system aims to accelerate the natural air flow in the ventilated gap in a forced way.

In this contribution, a comparative analysis of natural and forced velocity in the ventilated air gap is presented. Two cases are compared. The cooling effect of ventilated façade is dependent on the air velocity. The analysis of the temperature in the external face of the building wall with the presence of the

exterior ventilated façade in different conditions is done. The most important parameter to be analyzed and compared is the presence of vertical forced velocity in the air gap.

2.2 CFD solver applied to air movement in the ventilated façade gap

The here depicted methodology is a systematic investigation with Computational Fluid Dynamics and its application research in building systems. The literature is profuse in documents based on research applications of CFD, including experimental validations. Wang [11] modeled and validated the impacts of ventilation strategies and facade on indoor thermal environment for naturally ventilated residential buildings. Omar [12] compared CFD and Network models for predicting wind behavior in buildings. The results of the experiment supported the use of CFD for predicting wind performance in buildings. Furthermore, Omar [12] recommended CFD as a reliable method to study systems that have no access to laboratory or full-scale testing facilities.

Compared to other references like Wang [11] and Omar [12], who contrasted the results of the CFD simulation with real experimental results; this contribution assumes that CFD simulations are right to represent the fluid behavior. CFD is used as a design tool as Kang [13] used the methodology to improve natural ventilation in a large factory building. A numerical verification is made to check that the model is correct as well. CFD allows designers to obtain comparative results to take better design decisions of different façade configurations.

CFD enables designers to optimize their constructive solutions by simulation techniques and not by expensive trial-and-error methodologies, which is one of the most important advantages of computational models. In this methodology, CFD allows designers to try particular solutions in real scale models. CFD as design technique represents lower costs in terms of time and resources. It allows designers to have a general idea about the new system performance to predict whether it will work as expected or not. If the system works as expected, further studies should be done including additional simulations and experimental validation cases.

3. Mathematical model of the façade

Computational fluid dynamics (CFD) research uses computational and mathematical models of flowing fluids to describe and predict fluid response in problems of interest, such as the flow of air around a building. CFD is presented as an efficient, costless-effective tool for predicting systems response under a broad range of operating conditions. The advantage of using these models lies in the fact that they can reproduce real problems of Fluid Mechanics to any degree of complexity. Furthermore, they can visualize hydrodynamic aspects impossible to measure or represent in a real case (i.e. velocity stream lines) that have great importance in the comprehension of the studied phenomena.

The mathematical model is composed by a geometry where mass and momentum conservation equations are solved by the code. The geometry model is designed to work on three-dimensional meshes. The volume mesh in a simulation is the mathematical description of the space (or geometry) of the problem being solved.

The computational model solves numerically the governing laws of Fluid Dynamics. These equations, taking into account turbulent phenomena, are solved in a geometrical domain, given a number of suitable boundary conditions. In CFD the relevant velocity, pressure and temperature fields are calculated in a discrete manner at the nodes of a certain mesh or grid and they are represented along the mesh. The continuity or mass conservation equation solved by the software used is expression (1).

$$\frac{\partial \rho}{\partial t} + \nabla \cdot \rho \vec{v} = S_m \quad (1)$$

where ρ is the fluid density, \vec{v} is velocity and S_m represents the mass source contained in the control volume. Also, the momentum equation is considered by equation (2).

$$\frac{\partial(\rho \vec{v})}{\partial t} + \nabla \cdot \rho(\vec{v} \vec{v}) = -\nabla p + \nabla \cdot \vec{\tau} + \rho \vec{g} + \vec{F} \quad (2)$$

where p is the static pressure, τ the stress tensor defined in expression (3) and the gravitational (g) and outer forces (F) defined on the control volume, respectively. In (3) μ is the eddy viscosity and I is the unit tensor. The third term accounts for the effect of the expansion of volume.

$$\bar{\tau} = \mu \left[(\nabla \bar{v} + \nabla \bar{v}^T) - \frac{2}{3} \nabla \bar{v} I \right] \quad (3)$$

All conditions and properties are defined via STAR-CCM+ and solved using the coupled solver. The results are displayed via available post-processing tools.

3.1 Geometry

In this particular case, a façade is modeled in order to obtain the velocities profiles in the air gap and the temperature distribution across the air and the external building faces. The geometry modeled is a simplification of a ventilated façade in a building exposed to wind. The width of the control volume simulated consists of two half pieces which made the external ventilated façade layer and the narrow cavity between them (1.002 m. width). The height of the control volume is the wind tunnel height (9 m.). The depth of the control volume is made by the whole building shape inside the wind tunnel (11.5 m.). The building is 7.026 m. high and 6 m. deep. The air gap is 40 mm thick. Some details of the air gap and the dimensions of the building model are shown in Figure 1.

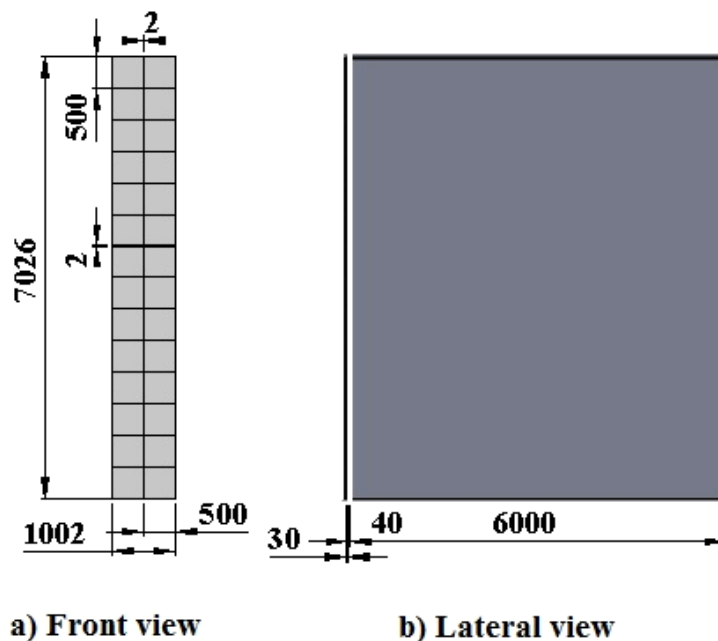

Figure 1. Building and panel dimensions (mm.)

3.2 Boundary conditions and physics

The CFD analysis performed includes steady state. Segregated flow for model is used. The gravity model is used as it permits the inclusion of the buoyancy source terms in the momentum equations when using the segregated flow model. K-Epsilon turbulence model is used for representing turbulence.

The entire domain is defined as a single fluid region (air). A region is a volume domain in space defined by boundaries. A boundary is each surface that surrounds and defines a region in the model. Each boundary has its own properties, defined in Table 1. Figure 2 shows the region modeled and the boundary conditions defined in the model. Three symmetry planes are defined as a boundary conditions (both laterals and the top of the wind tunnel), velocity inlet in front of the principal ventilated façade, mass flow outlet at the end of the wind tunnel and simple walls (ceramic panels and building faces). The ceramic panels and the building faces are defined with a roughness height. The roughness height is set $2.5 \cdot 10^{-7}$ m.

Table 1. Boundary conditions specifications

Type	Surface (Wind tunnel)	Properties
Velocity Inlet	The front face	Velocity module and direction (0.5 m/s)
Mass flow outlet	The back face	By default
Symmetry Plane	The upper and lateral faces	By default
Wall	Bottom face	By default
Wall	All building and façade faces	Roughness height = $2.5 \cdot 10^{-7}$ m.

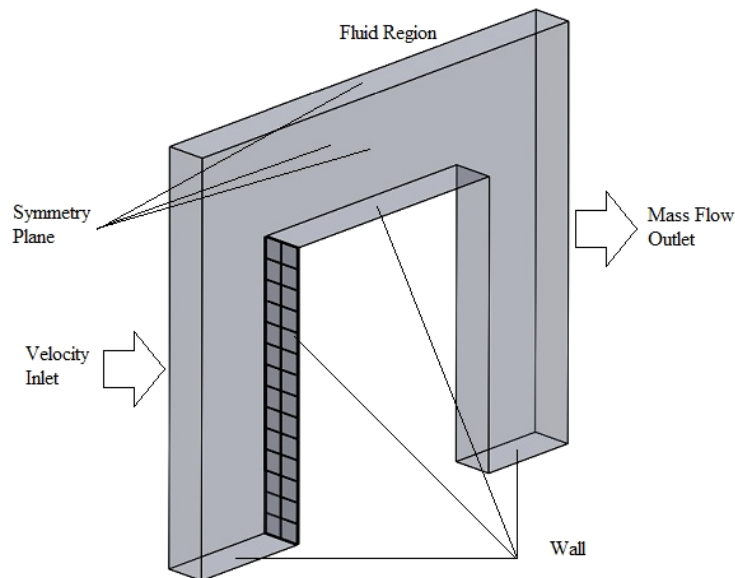

Figure 2. Boundary conditions for CFD model

3.3 CFD mesh and convergence

The numerical method is solved by the finite volume technique. The solution to a flow problem is solved by calculating the flow-equations on the nodes within the cells. The accuracy of the result depends on the definition of the nodes. The definition of a good mesh is crucial to find the optimum between the smallest number of nodes and the accuracy of the results. Finally, the mesh for the volume control used has the following characteristics: 443,568 items; 1,289,740 internal faces and 535,984 vertices (Figure 3). The roof of the building is meshed with a boundary layer mesh.

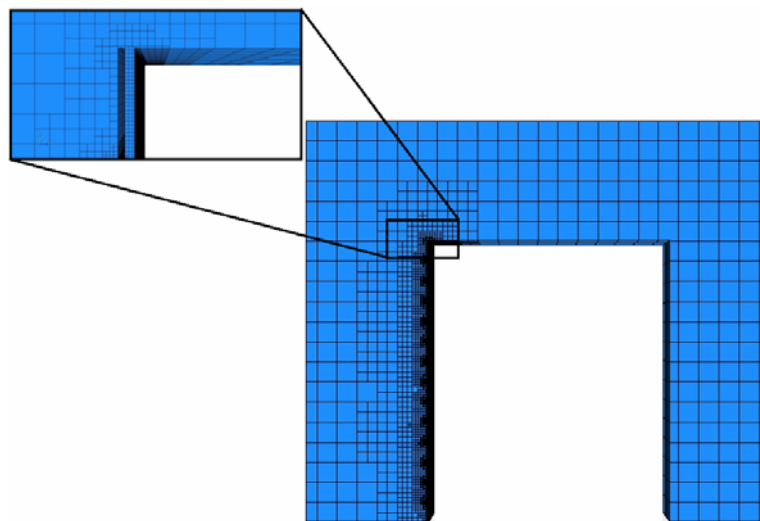

Figure 3. Detail of the volume control mesh for CFD model

Once the volume is discretized in the mesh, the numerical models for the representation are chosen. 3D steady state model is implemented, with constant density fluid flow and second order segregated flow. Wall treatment is necessary for modeling up proper boundary conditions for turbulence. In this case the wall treatment used is the high- y^+ . The high- y^+ wall treatment implies the wall-function-type approach in which it is assumed that the near-wall cell lies within the logarithmic region of the boundary layer. It is suitable for use with models that do not explicitly damp the turbulence in the near-wall region. While a good rule of thumb is that the wall-cell centroid should be situated in the logarithmic region of the boundary layer ($y^+ > 30$) [14], as in the present cases. Correct values of y^+ allows a proper assessment of the mesh. In this case, this requirement was accomplished for all walls. When the mesh has been completed, a grid-independence study, including the number of nodes and the size of the enlarged domain was performed in order to ensure the validity of the numerical computational procedure.

3.4 Simplifications assumed

Several simplifications are assumed to reduce the computational time. The simplifications are indicated below.

- a) The study is focused on the air gap between the inner and outer panels, for that reason it has been considered the same temperature in the outside environment and in the façade surface in contact with the same.
- b) The capacity of the ceramic panel of the façade to accumulate heat energy is not taken into account when calculating the heat transfer through the inner sheet.
- c) The modeling is considered steady. The temperature boundary conditions are specially chosen to benefit the additional cooling effect of the ventilated façade. Real conditions in summer Mediterranean climates are assumed, measured in laboratory conditions for real ventilated façade panels.
- d) Steady sunlight action is considered for the outer ceramic panel.

4. Results and post-processing

As mentioned, two different cases are compared to quantify the energy improvement of the systems designed. The models nomenclature is:

- Case (a) Building with ventilated façade: wind forced velocity for the air in the gap.
- Case (b) Building with ventilated façade and additional vertical forced velocity in the air gap by fans.

The control volume studied is defined by the internal ventilated façade panel, the narrow ventilated cavity and the buildings external wall. Figure 4 shows the control volume definition. This control volume is especially chosen to determine the temperature effect of the air flow through the cavity in the building external wall. However, the model is composed of more elements to properly simulate the air entrance in the ventilated cavity.

Figure 4 shows nomenclature of temperatures. External conditions make the temperature of the interior ventilated façade panel (T_1) to be 35 °C (308°K). The temperature of external air T_{air} has been set 30°C (303°K). With these considerations, the temperature of the buildings external wall (T_2) is then calculated, considering all the thermal and fluid dynamics effects in the cavity.

The CFD model simulates the air velocity in the gap depending on the exterior wind around the building and taking into account all the hydrodynamic effects: the narrow apertures of the ventilated façade, the friction forces, the wind driven flows, the buoyancy natural ventilation, gravity, etc. Velocity and temperature T_2 are solved among other magnitudes.

4.1 Case (a) Building with ventilated façade. Natural ventilation

The first CFD simulation is set with the boundary conditions defined in Section 3.2. To represent velocity vectors it is necessary to define planes in the fluid region. Figure 5a shows velocity vectors in a parallel plane defined in the centre of the ventilated gap in the façade. Figure 5b shows velocity vectors in a perpendicular plane. It is observed that the velocity in the air gap is progressively being accelerated as wind flow inside on it. Figure 5a shows that the velocity in the bottom of the façade is very low (less than 0.3 m/s).

Temperature of the internal side of the façade panel is considered as constant value: $T_1=308^\circ\text{K}$. Due to the wind incidence on the façade, the building external wall decreases its temperature. Figure 6 shows both, the internal wall of the ventilated panel and the external wall of the building. The color bar allows

to observe that the temperature has been decreased in the external building façade ($T_2 \approx 305.5^\circ\text{K}$, green color) respect the internal panel face ($T_1 = 308^\circ\text{K}$, red color).

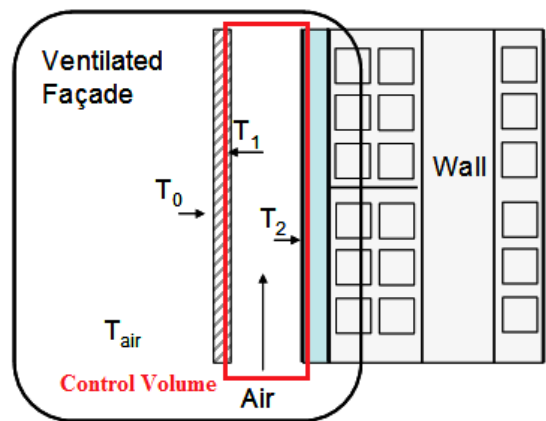
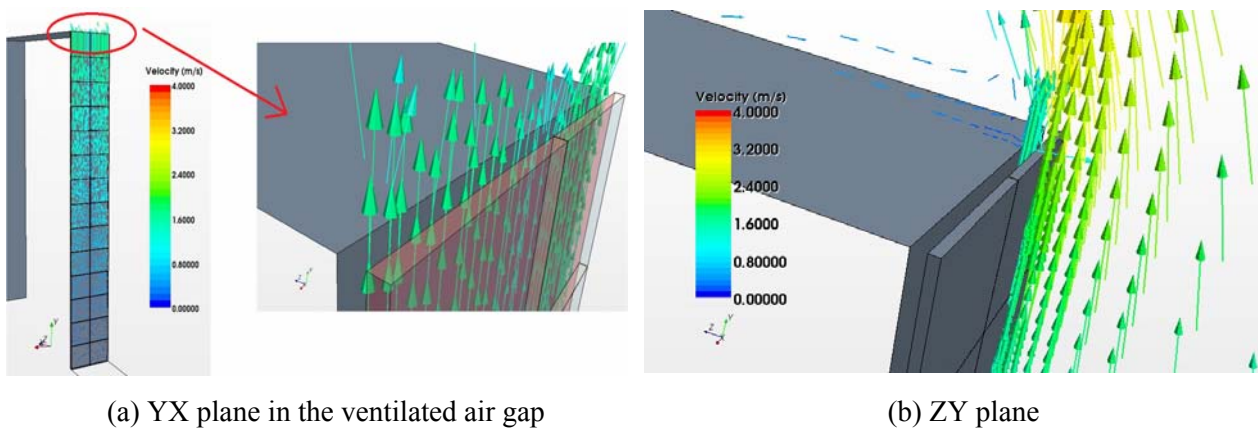

Figure 4. Control volume and temperatures definition



(a) YX plane in the ventilated air gap

(b) ZY plane

Figure 5. Air velocity vector detail

4.2 Case (b) Ventilated façade with forced vertical velocity

The second CFD simulation is performed by adding a new boundary condition to the previous model. This boundary condition is set in the bottom face of the ventilated cavity. The boundary simulates a forced vertical velocity. The forced vertical velocity is set $v_z = 0.3$ m/s. The temperature of this forced air has been set 30°C equal to external temperature, T_{air} (303°K). Figure 7 shows bottom area in which the new velocity boundary condition is set.

4.3 Case (a) and (b) comparison

The objective is the comparison of the temperature in the external face of the building in both cases, a and b. The mentioned difference is that in case (b) an additional forced velocity is set in the bottom of the ventilated gap. Therefore a new boundary condition is set to simulate the additional forced velocity in the ventilated cavity.

Velocity inside the gap is shown for both cases velocity control line visualized in Figure 8. Velocity is presented in a line since the centre of the ventilated panel. Figure 8 shows that the air velocity in the ventilated gap has been increased for the whole height. Case (b) as has an induced flow, presents more velocity along the whole simulated height.

Figure 9 indicates the external building face temperature. It can be clearly observed the temperature difference in the lower building floors (T_2). As the air flow in the cavity rises, this temperature reduction in the building external façade is progressively being lost (Figure 8b).

Therefore, it indicates that there is a limit on the height where the initial forced air has thermal effect for those boundary conditions. To propose a quantification of this effect, the Influenced Height (H_1) is

defined, this is the height in which the temperature difference respect of the largest temperature difference achieved between cases is less than 10%. This is the maximum height in the building in which the thermal effect of the forced velocity will be significant (10% variation).

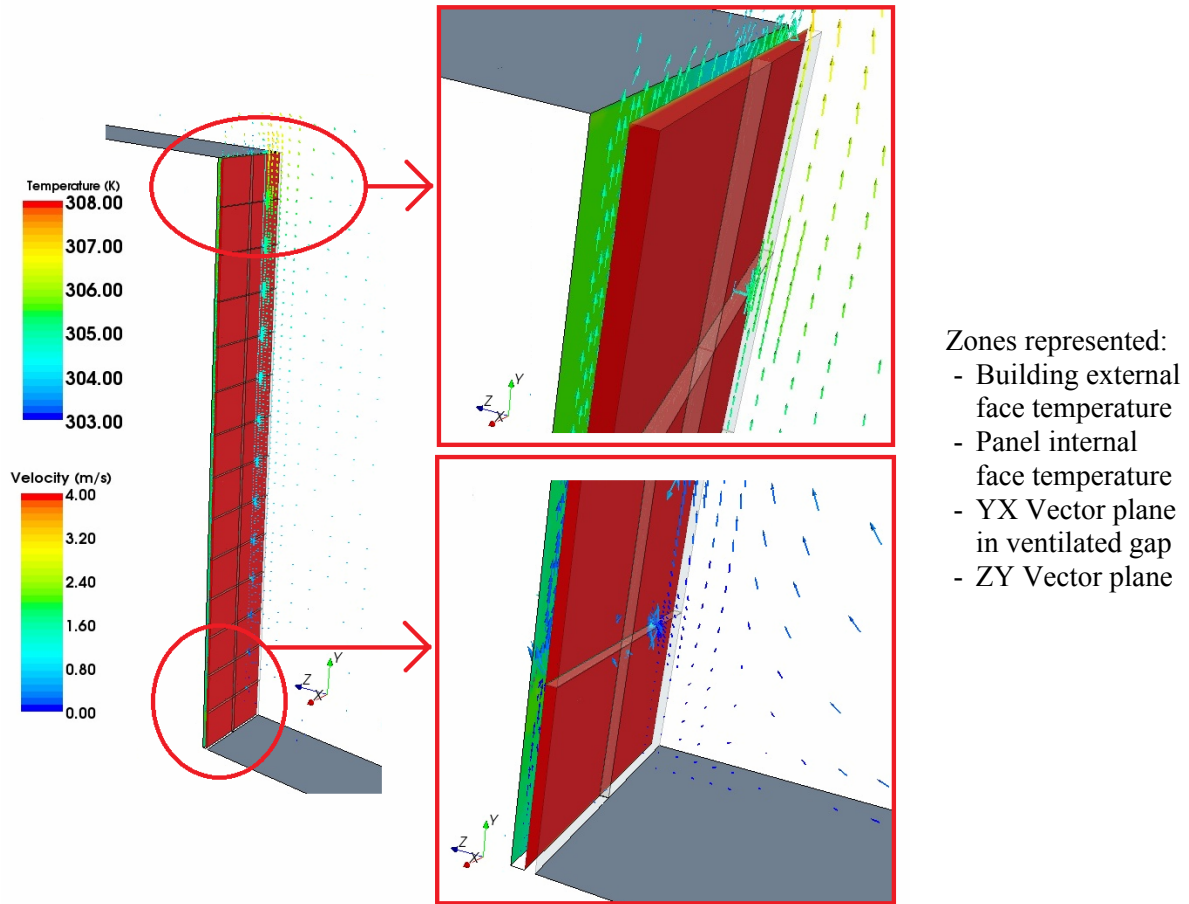

Figure 6. Temperature and velocity vectors detail case (a)

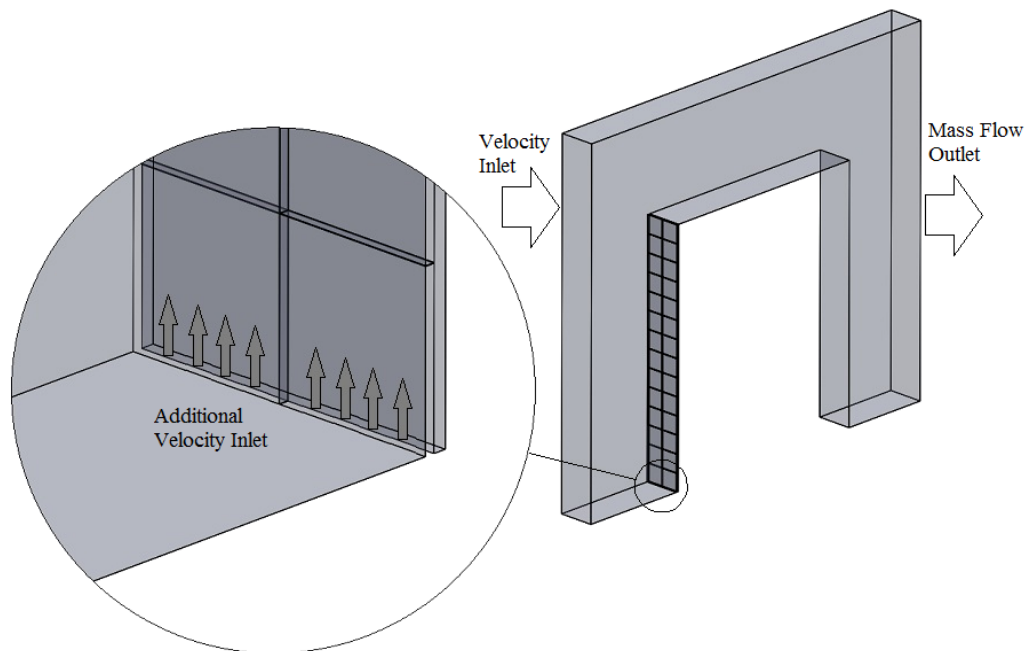

Figure 7. New velocity inlet boundary condition

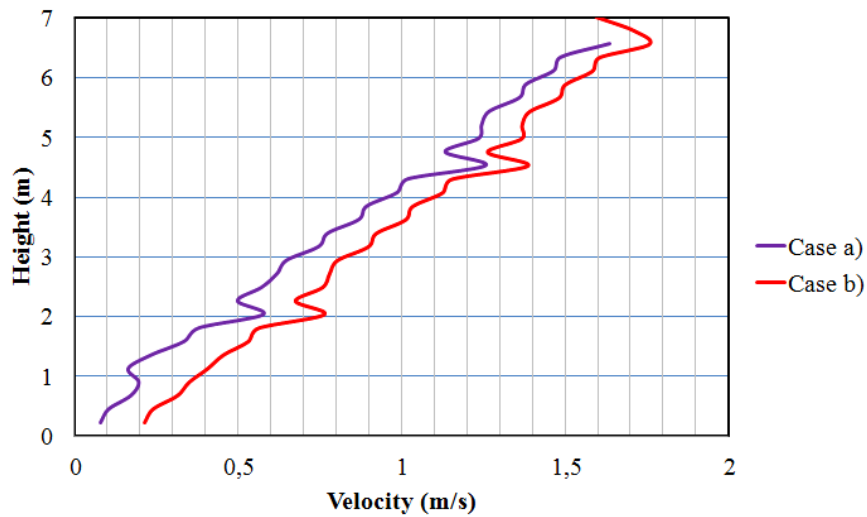

Figure 8. Velocity calculated in the centre of the ventilated cavity

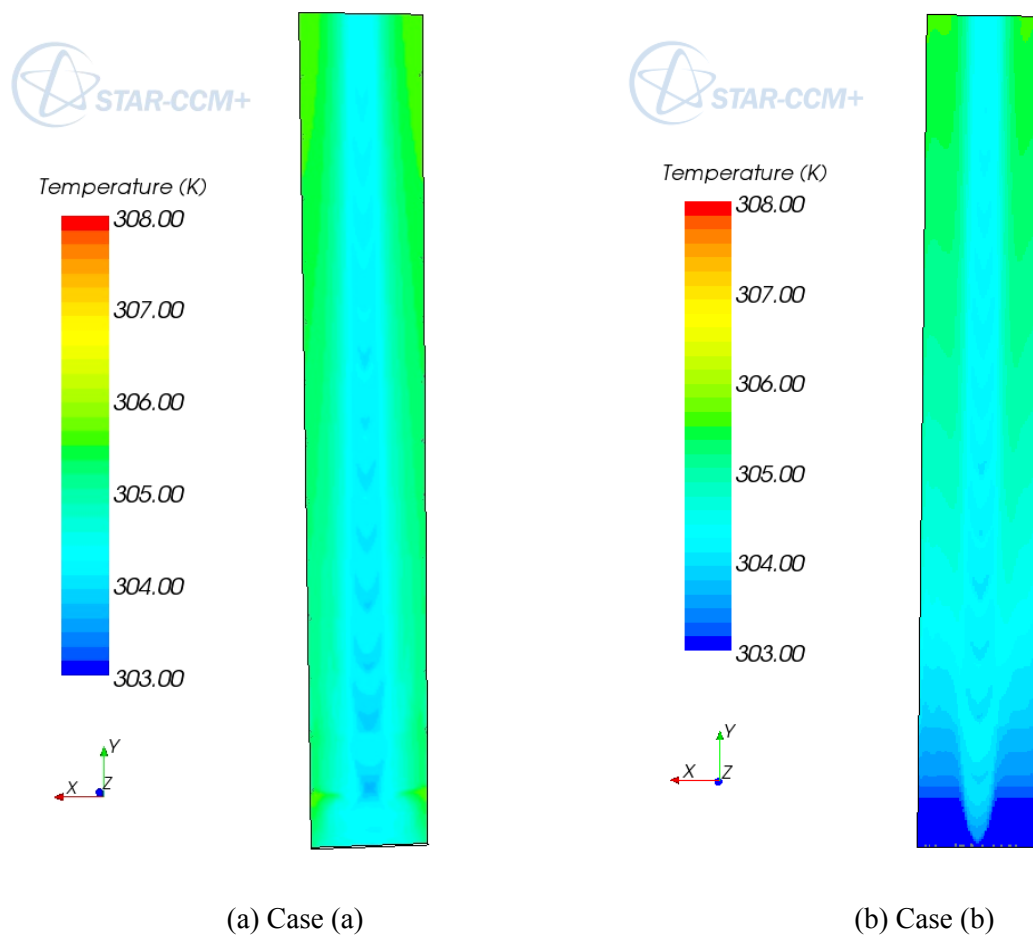

Figure 9. External building face temperature comparison

The temperature control line shown in Figure 10 is a projected line since the centre of the ventilated panel on the external buildings face. Figure 10 depicts that the temperature effect is really reduced with height. This reduction depends on the initial air temperature and velocity set. Consequently, the height limit where the initial forced air has no thermal effect depends on the initial forced air temperature and velocity.

To determine the height limit it is necessary to set a temperature difference reference ($T_{A0}-T_{B0}$) maximum in the base of the building. This reference must be the largest temperature difference achieved between both cases which should correspond with the temperature difference determined at a lower height. Then, expression (4) is used to determine the temperature difference variability with height. Finally, an exponential equation is used to set the equation linking temperature difference percentage and height shown in Figure 11.

$$10=x \cdot \frac{T_A - T_B}{T_{A0} - T_{B0}} \cdot 100 \tag{4}$$

Expression (5) determines the limit height where the temperature difference is less than 10%. For this particular case, the limit height is 4.7 m.

$$h = 35.2 \cdot x^{-0.901} = 35.2 \cdot 10^{-0.901} = 4.7 \text{ m} \tag{5}$$

According to this over this height the additional forced ventilation has no meaning thermal variation effect on the façade.

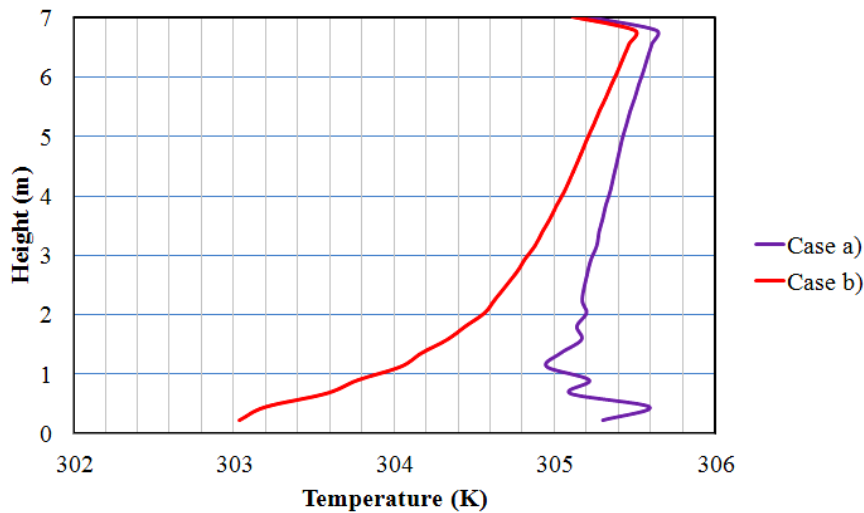

Figure 10. Temperature T_2 calculated in the external face of the building

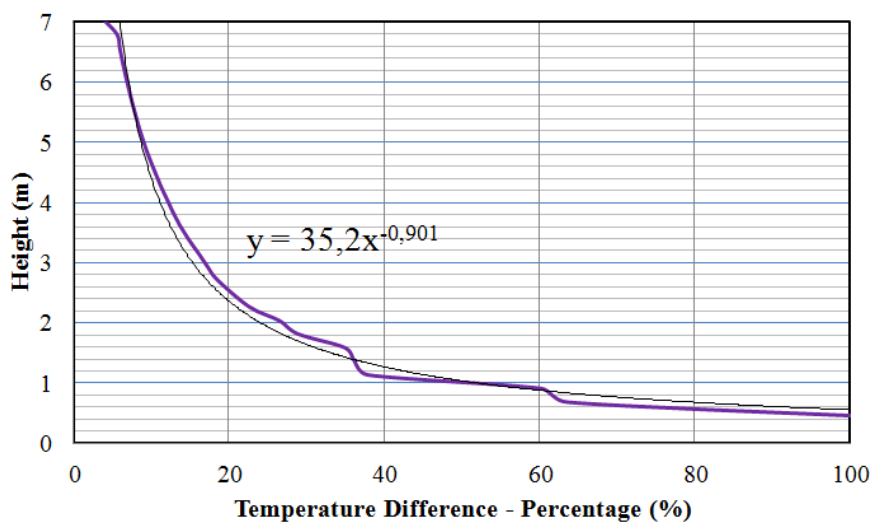

Figure 11. Temperature difference (%) vs height (m)

5. Conclusion

Quantification of the ventilated façade effect in a building is a complex phenomenon. In the present contribution a strategy to quantify this effect is proposed under certain conditions making use of the computational fluid dynamics modeling. Two simplified CFD models for the ventilated façade have been presented. These simple simulations are useful to investigate the ventilated façade behavior and the ways to improve it. A system which aims to accelerate the natural air flow in the ventilated gap in a forced way has been analyzed to improve the cooling capacity of ventilated façade in summer conditions. Results of both cases are compared to determine the effect on wall temperatures of installing the additional system in the initial model. Some conclusions can be achieved:

- The velocity of the air in the façade's air gap is crucial for the heat interchange.
- This velocity is strongly related to the temperature conditions, as it is wind and advective forced.
- When this velocity is additionally forced, the efficiency of the ventilated façade increases depending on the ventilation action.

Is therefore clear that the model requires a more complex mathematical modeling to integrate the heat transfer phenomena on the solid wall and the panels. In this paper the strong influence of velocity on thermal effect is demonstrated and quantified by means of the defined Influenced Head. There are many parameters affecting the efficiency of the whole installation: the separation between the panels, temperature and air velocity of incoming solar radiation and temperatures of solid elements, the heat transfer coefficients of the solid elements, etc. However, this computer modeling can be used to perform a simple sensitivity analysis by varying these parameters. Nowadays, with current computing capabilities, the optimum operating solutions can be estimated, especially when in future the phenomenon of radiation in the solid parts of wall and can be incorporated and tested to integrate non-permanent thermal inertia.

References

- [1] Balocco, C. A simple model to study ventilated façades energy performance. *Energy and Buildings*, Vol 34, N 4. Pp 469-475. 2002.
- [2] Chen Q. Ventilation performance prediction for buildings: a method overview and recent applications. *Building Environ* 2009;44(4):848e58.
- [3] Li Y, Nielsen PV. CFD and ventilation research. *Indoor Air* 2011;21(6):442e53.
- [4] Linden, P.F. The Fluid Mechanics of Natural Ventilation. *Annual Review of Fluid Mechanics* 2009. 201-208.
- [5] Kokogiannakis, G.; Strachan, P. Modelling of double ventilated façades according to the CEN Standard 13790 method and detailed simulation. 547 2nd PALENC Conference and 28th AIVC Conference on Building Low Energy Cooling and Advanced Ventilation Technologies in the 21st Century. Crete island, Greece. 2007.
- [6] Gang, G. A parametric study of Tromble walls for passive cooling of buildings, *Energy and Buildings*, Vol 27, N 1. Pp 37-43. 1998.
- [7] Manz, H. Numerical simulation of heat transfer by natural convection in cavities on façade elements. *Energy and Buildings* 2003, Vol 35, N 3. Pp 305-311.
- [8] Yilmaz, Z. Evaluation of energy efficient design strategies for different climatic zones: Comparison of thermal performance of buildings in temperate-humid and hot-dry climate. *Energy and Buildings* 2007, Vol 39, N 3. Pp 306-316.
- [9] Ciampi, M.; Leccese, F.; Tuoni, G. Ventilated façades energy performance in summer cooling of buildings. *Solar Energy* N. 75 - 2003. Pp 491–502.
- [10] López P.A.; Mora-Pérez M.; López G.; Bengochea M.A. Model of ventilated façade in buildings by using CFD techniques. *Boletín de la Sociedad Española de Cerámica y Vidrio*, Vol 50 – 2011. 99-108.
- [11] Wang L., Wong N. H. The impacts of ventilation strategies and facade on indoor thermal environment for naturally ventilated residential buildings in Singapore. *Building and Environment* 42 (2007) 4006–4015.
- [12] Omar S. A., Mohamed B. G. A comparison between CFD and Network models for predicting wind-driven ventilation in buildings. *Building and Environment* 42-2007. 4079–4085.
- [13] Jong-Hoon Kang, Sang-Joon Lee. Improvement of natural ventilation in a large factory building using a louver ventilator. *Building and Environment* 43-2008. 2132–2141.

[14] CD-Adapco Star CCM+ User's Manual.



Miguel Mora Pérez M.Sc.in Industrial Engineering, Master in Energy Technology for Sustainable Development and Research Engineer in the Department of Hydraulic Engineering (Universitat Politècnica de Valencia). He is currently researcher at Universitat Politècnica de València in the E3 project in subjects related to sustainability in buildings. This project is cofounded by the National Government of Spain.



Gonzalo López Patiño is Industrial Engineer, Assistant Professor in the Hydraulic and Environmental Engineering Department at the Universidad Politècnica de Valencia. He is currently Director of the Master Programme in Construction and Industrial Facilities at Universitat Politècnica de València. He has more than a decade of experience in modelling building and urban facilities, especially in fluids applications (air, water and other industrial flows) and actually he has focused his researches in sustainable applications on building constructions.



P. Amparo López Jiménez M.Sc. and PhD in Industrial Engineering, Associate Professor in the Hydraulic and Environmental Engineering Department at the Universidad Politècnica de Valencia. She is currently the Associate Director of the Hydraulic and Environmental Engineering Department of Universitat Politècnica de València. She has more than a decade of experience in research and teaching in Engineering fields, always related to hydraulic topics. She is author and editor of several publications about Hydraulic an Environmental Engineering and Flow Dynamics. She has participated in national and international R&D projects and co-organized International Seminars and Networks. She is an experienced University Teacher, an active researcher and a former practicing engineer.