

**COMPARATIVE STUDY BETWEEN SZCZECIN AND
VALENCIA OF THE CONSTRUCTION OF THE TRAMWAY
INFRASTRUCTURE**



AUTHORS:

TANIA PÉREZ TOMÀS

IRENE TAMARIT LATRE

INDEX

CHAPTER 1: INTRODUCTION	3
1.1 Objectives and justification of the study.....	4
1.2 Relationship between architecture and engineering.....	5
1.3 Advantages of the trams	8
CHAPTER 2: HISTORICAL CONTEXT	10
2.1 Introduction of Tramway History	11
2.2 History and Evolution of Szczecin tram.....	13
2.3 History and Evolution of Valencia tram.....	17
CHAPTER 3: URBAN CONTEXT	18
3.1 Coverage of tram according to its urban evolution	19
3.2 Red Tram: comparison of Szczecin and Valencia	31
3.3 Economic-social context.....	35
3.4 Areas chosen for the study.....	39
CHAPTER 4: STUDY AND ARCHITECTURAL ANALYSIS	44
4.1 Role of tram tracks	45
4.2 Types of tram tracks	46
4.3 Architecture in tram net.....	48
CHAPTER 5: STUDY AND CONSTRUCTIVE AND EQUIPMENT ANALYSIS	56
5.1 Construction details	57
5.2 Type of materials and suitability	66
5.3 Material-temperature-resistance relationship	72
5.4 Equipment used	80
5.5 Execution process.....	90

CHAPTER 6: STATE OF CONSERVATION	114
CHAPTER 7: SAFETY AND HEALTH	129
7.1 Input data for the development of the study	130
7.2 Safety instructions for access and movement of people	133
7.3 Hygienic services, first aid, dining room and other venues of service and use...	136
7.4 Measures in case of emergency and safety instructions.....	138
7.5 Preventive measures, individual and collective protection.....	141
7.6 Comparison study with real works.....	149
CHAPTER 8: CONCLUSIONS	159
8.1 Critical Evaluation.....	160
8.2 Personal Evaluation.....	161
CHAPTER 9: BIBLIOGRAPHY.....	162
CHAPTER 10: GRATEFULNESSES	166

CHAPTER 1: INTRODUCTION

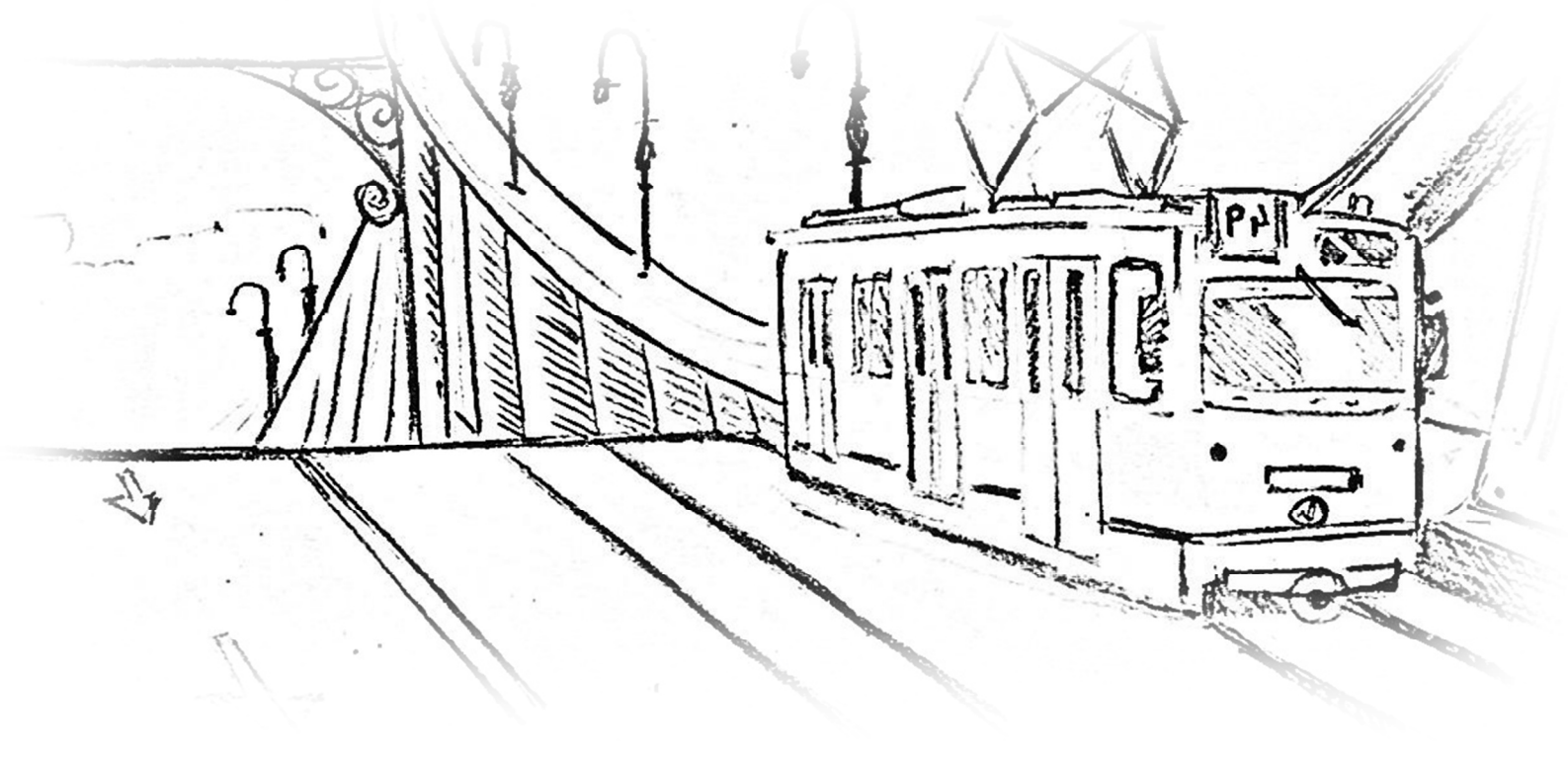

1.1 OBJECTIVES AND JUSTIFICATION OF THE STUDY

Objective of the project

The main object of the final degree project is the elaboration of a comparative study of the infrastructure of trams in the cities of Szczecin and Valencia.

To do it, an analysis of the historical and urban context of both cities, indicating the evolution of this transport from its beginning to its current status is performed.

Then the conservation status will be checked, evaluating the existing pathologies and their possible causes and solutions.

Finally, a study of the safety and health of workers in Szczecin works will be performed, and we provide a comparison of the study and actions in reality works in safety and health, through the work visits that we have made.

Justification of the project

Our study is of interest because the city of Szczecin are carrying out works to improve the way so we have visual information forms of labour, materials, manner of use of equipment, as well as measures safety and security.

Also, the use of the tram in Szczecin is very important since it has been a widely used throughout the history and its infrastructure connects many parts of the city.

1.2 THE RELATION BETWEEN ARCHITECTURE AND ENGINEERING

Architecture is known as the creative part of the construction and design, the correct distribution of spaces and their execution. The Engineering uses that creativity and helps to learn the real possibilities of construction on a quantitatively and qualitatively way: structures, materials, shapes. etcThanks to the engineering, calculations and related procedures are done to ensure its stability and structural viability.

Definitely Architecture and Engineering are two arts with remarkable differences but necessarily complement to obtain a safe and correct result.

For underground and tramway infrastructure, we can find this relation between Architecture and Engineering at stops and stations.

Both, in Szczecin and Valencia we can see a variety of typologies. Especially in Valencia where they have recently built subway stations with a significant architecture value as for example the Alameda Station designed by the architect Santiago Calatrava. This station, opened in 1995, is located in the old bed of Turia river close to The City of Arts and Sciences also designed by Santiago Calatrava.



Alameda Station. Source: www.valenciaguia.com

The latest great project in Valencia has been the Joaquin Sorolla station which connects the underground (lines 1 and 5) with the AVE (Spanish High Speed Train). This is a provisional structure that will be dismantled when the Valencia Central Railway Station opens. The project has been designed by architect Cesar Portela and it will integrate the emblematic Valencia North Railway Station, and an underground railway station with 12 roads and walkways on two levels 6 ways each. A large underground parking and a building for tertiary uses complete the project.



Estación del Norte. Source: www.urbanity.es



Joaquin Sorolla station.

Source: arquitecturaresopal.wordpress.com



Central station. Source: oconowoccc.com

Another remarkable station in Valencia is the new Estación Empalme (built in 1998 and opened in 2001). Being its author M. Sánchez-Robles Beltran; with metal frame and large window this station as well as the Joaquin Sorolla, has a quite functional architecture.



Empalme station. Source: www.panoramio.com

The Estación Empalme connects the line 1 of the underground with the line 4 of the tram.

Underground stations of populations that are outside of Valencia city, they all have the same architectural trends. Functionality, economy and standardization have conditioned these constructions of classic style.



Paterna station. Source: www.panoramio.com

However tram stations are usually more simple in both cities. They have a simple metal marquee and a bank enough to shelter from the rain or the sun during the wait; in Szczecin sometimes even in some secondary stops this structure is omitted and only installed an informative post.



Pont de Fusta stop. Source: www.urbanrail.net

We have found that the relation between Architecture and Engineering in Szczecin is a bit sparse; this city has only a net of trams and as we have seen that tram stations are always more simple than the underground. However it is trying to perform a fast-tram project in which we can see very clearly this fusion of Architecture and Engineering.

Fast-tram will offer a great transport for crossing the city from East to the West and it will provide to Szczecin of a futuristic look thanks to modern forms fusing cement with large glazed areas.

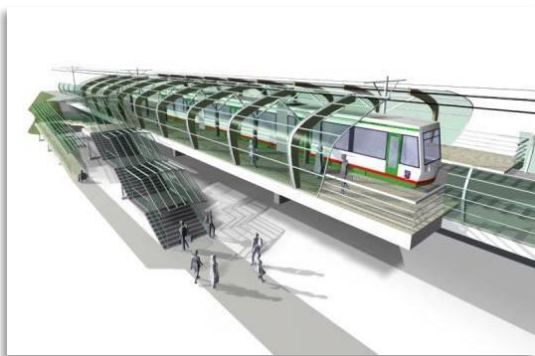

Fast-tram Project. Source: Euroinfrastructure.eu



Fast-tram Project. Source: Euroinfrastructure.eu

1.3 ADVANTAGES OF THE TRAMS

Today, the trams have become a very important transport system in all cities for the facilities to move and the number of advantages.

1. Respectful of the environment

One of the main advantages of the tram-train is the lowest amount of pollution with respect to other means of transport. Being a mean of transport that uses electricity there is no emission of noxious gases in its utilization.

Trams can run on renewable electricity without the need of very expensive and short life batteries. Noise produced by modern trams are less annoying. On the other hand the use of solid axles wheels produce a characteristic noise like a squeal, mainly on curves.

2. Comfort

Another advantage of the tram is that it can accommodate the number of passengers at any time by adding or removing cars according to need at peak hours. More smooth and comfortable journey for passengers compared to buses due to the control of braking and acceleration especially on curves. The lane used by the tram allows for a smoother driving than roads used by buses.

3. Accessibility

Accessibility is simpler because there are no stairs or other barriers to access to the platforms, and there are trams "low floor" with the platform at ground level which saves time at stops, By allowing almost complete accessibility , is very attractive to people with reduced mobility, pregnant women and older people improving their independence.

These advantages can not be found in the subway, with too many stairs, mechanical stairs and sometimes located outside the city center.

4. Little space

Occupies a narrower line than its need for a bus because there is no lateral displacements, which rationalizes the use of scarce urban public space especially in cities with dense population and narrow streets.

5. Fast, safe and effective

The multiple entrances to tram allow passengers quicker access than city buses which tend to have only one access. All this combined with the speed of acceleration and braking allows the tram to maintain a more rapid speed than the bus.

As all the tram routes are designed as a result we get a faster and attractive service.

The tram can pick up the passengers in residential areas with the same facility that a bus and also to operate in pedestrian areas in a safely way because it never deviates from the marked out route.

Reduction in number of accidents by eliminating private vehicles off the road with a greater sense of security in urban centers.

As the tram rails are visible it is easy for drivers to know where the tram is circulating and thereby prevent mistakes and accidents.

6. Cheaper

Although the entire of the trams infrastructure was very expensive in their construction, the cost of the cars and rails has become cheaper due to the application of new technologies.

Once lifted the infrastructure, the tram system is the cheapest public transport with an expectation of use of at least 50 years

We can say in conclusion that the tram is the best public transport because it helps to reduce traffic congestion providing passengers with a quick, timely and sustainable means of transport.

CHAPTER 2:
HISTORICAL CONTEXT

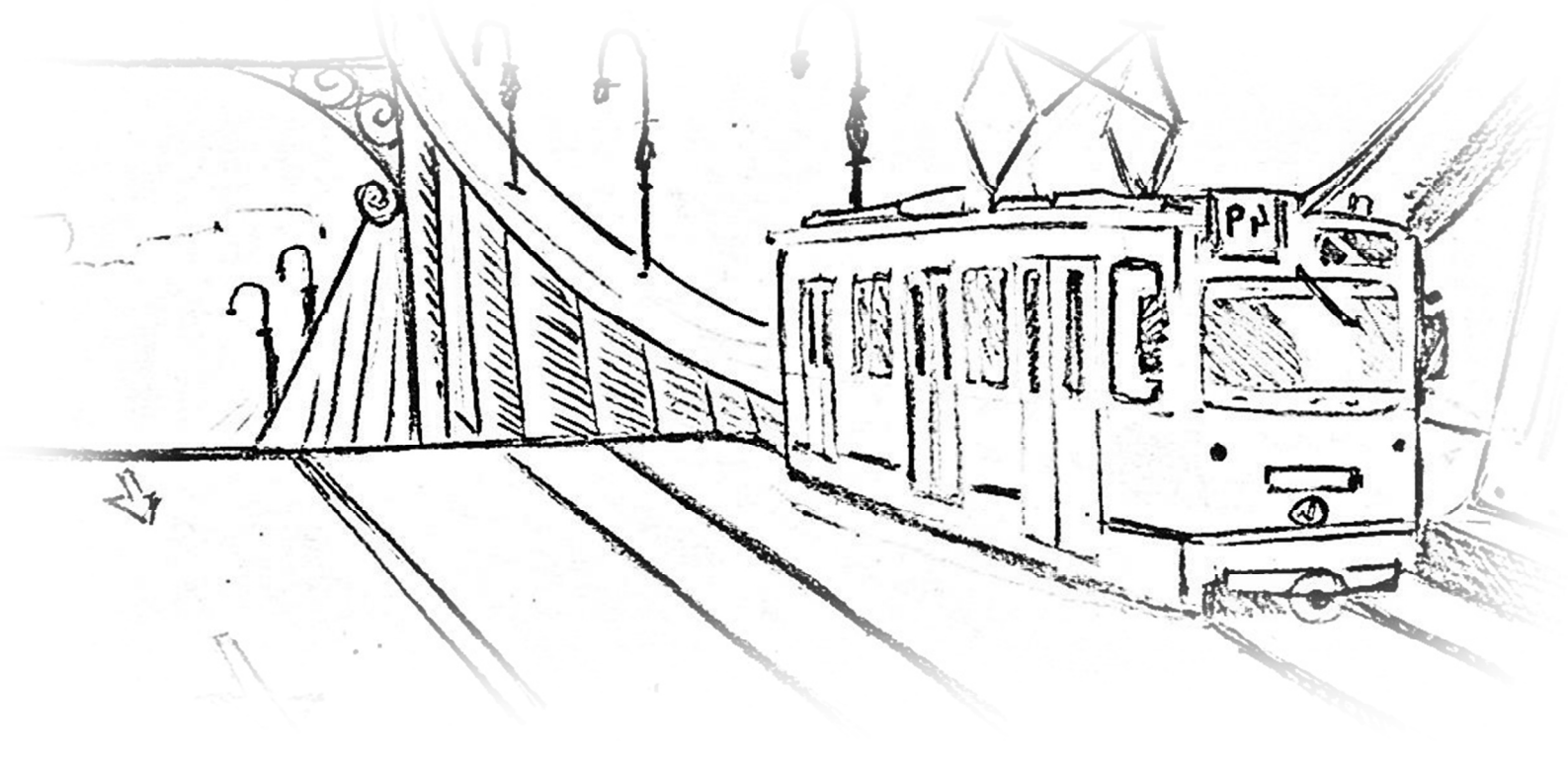

2.1 INTRODUCTION OF TRAMWAY HISTORY

The first rail passenger services in the world began in 1807 between the populations of Swansea and Oystermouth carrying materials between the quarry and the port; soon emerged a strong interest in the people transportation. The original trams were pulled by horses.



First tram Swansea-Oystermouth (UK).
Source: www.chasewaterstuff.wordpress.com

In 1932 began to operate the first tram dedicated exclusively to transport people; this line it belonged to the neighborhood of Harlem in New York. Three years later began to run the New Orleans Tramway still operating today afterwards 150 years of activity.

In Europe the first line opened in Paris (1853). In the 1870s we can highlight the arrival of tramway in Madrid, Spain (1871) and in Dusseldorf, Germany (1876) where it is still operational today. The limitation of horse-drawn obligated to search for alternative methods of traction.

In Europe, it began to circulate in Paris around 1854, arriving in Spain in 1871 and Düsseldorf, Germany, in 1876. The limitations of animal traction forced to search for other methods of traction.

Steam traction attempts were made such as railways, by a small steam engine; but the discomfort caused by the smoke and excessive noise not made popular this system and it was considered unsafe. In 1881 appeared the electric motor; this system had more advantages than the steam engine.



First electric tramway Lichterfelde(Berlin)
Source: www.bbc.oc.uk.

In the late 19th and earliest 20th there were not a predominant system of traction and other alternatives starting to appear. Cable tram was the only alternative but it was very expensive and had no success.

In early 19th century the electric motors were invented. This fact enabled the implantation of trams with electric motors obtaining a great success and becoming the best option even at the present.

In 1881 the first line of electric tram was opened. It was in Lichterfelde, near Berlin. With these new lines, the first serious problems with pedestrian safety began to show because the electrical current streamed through rails. For this reason other alternative energy systems were considered and changed by simple suspended cables on where a machine called pantograph was connected. In 1883 starts up the first tram line using the catenary system - overhead power line that transmits electricity to locomotives- in Interbrühl Mödling, near Berlin.

During the last two decades of the 19th Century and the first three decades of the 20th Century the Electric tram experimented a notable expansion because it offered an inexpensive and safe transport for the population and at the same time improved the socioeconomic relations in urban areas by facilitating expansion from the city to the suburbs.

In the following decades there was a progressive disappearance of the tram; they were several causes but in 1920 the manpower and materials needed to keep the lines of tram suffered a considerable increase.

The public authorities have invested, especially the networking bus and infrastructure for the cars, perceived as the symbol of progress. Car production was cheaper with the introduction of new production lines.

The road infrastructure was improved. The population fascinated by progress and autonomy that offered private car asked more space for cars in cities. Private cars and buses emerged as tram replacers.

Another cause that were able to promote the disappearance of the tram was the financial crisis of USA that sunk the European economy and the devastation suffered by the Second World War

In order to take advantage of electrical lines used by trams in several cities trams were replaced by trolleybuses - buses powered by electric energy - but this type of transport was a complete failure.



Trolleybus. Source: www.tramz.com

2.2 HISTORY AND EVOLUTION OF SZCZECIN TRAM

The first tram to have ever moved along the streets of Szczecin appeared in the city on August 23, 1879. Its route led from the Hold Pruski Square to Brama Portowa via the Orla Bialego Square (Rossmarkt). Further on it forked in the direction of Lekno and Golecino. Back then the cars were drawn by horses of course.



Museum of technology Szczecin.

Source: author

It had not been until July 4, 1897 that an electrical tram started to carry citizens of Szczecin. Only the main route was a double-track one at that time; trams running along side routes had to stop and wait for their turn sidings.

In 1926 a huge shipment of 40 cars was delivered to Szczecin from factories in Bremen and Dessau. Despite the fact they were manufactured both in Dessau and at the Nordwaggon Bremen factory, they were all called “Bremens” in Szczecin. Those were the oldest tram-cars that were lucky enough to survive WWII in depots. The Bremen was a modern tram-car in its time, just to mention its roofed platforms. There was a special casket placed on the top of the car into which a plate would be inserted to inform passengers about the route’s number and direction. At night the casket was illuminated.

Bremen train-cars were seen for the first time in Szczecin in the mid 1920’s. All cars were painted the same colour at that time, i.e., ivory. Car numbers were yellow.

Different paint coats were applied in 1912, the time when the city of Szczecin took tram-cars over from a private company. Trams running along the same routers were painted the same.



Museum of technology Szczecin.

Source: author

Until 1954 there had been no new tram-cars introduced to the streets of Szczecin. The design of Nk tram-cars was based on that of German KSW cars that had been manufactured during the war-time. KSWs had been assembled in such a way as to allow for a quick evacuation in the event of an air-ride, so they

had been fitted with disproportionately big platforms and wide doors. Nk cars inherited those wide panel doors that in the first models were operated manually. Nk cars could carry 70 passengers in total, including 12 seats. They could move both forwards and backwards. Similarly to old Bremens, they were operated via crank handles.

The first ten 102Na tram-cars arrived in Szczecin in 1971. Those were the first quick-running trams in Poland. In comparison to tram-cars and Enkas of pre-war period, they appeared as extremely luxurious and modern vehicles.

Crank handles and wooden seats – these are the things that come to their minds when Szczecin residents who grew up in the 1970's try to recall the tram of their childhood days. Those tram-cars, known as Nk cars, were manufactured in Chorzow in the 1950's. and there was only one driver's cabin located at one end of the vehicle.



Museum of technology Szczecin.
Source: author

In 1970's tram conductors in Szczecin were gradually replaced by validating machines. In 1971 all remaining pre-war tram-cars were withdraw machines from the public transport network.

Drivers seats at both ends of the car had been a necessity until eventually all last stops at all tram routes in Szczecin were transformed into loop lines. The last loop line was built in 1973 in the Goclaw district.

When 102Na hinged tram-cars began to fall apart, we wasted no time and started to look for some replacements. And this is how GT6 trams arrived in Szczecin.

The first shipment containing 12 second-hand cars was delivered to Szczecin from Düsseldorf in 1996. Those trams were applied a general overhaul and had been modernized before. They



Museum of technology Szczecin.
Source: author

were fitted with a door opening system that allowed passengers to open individual doors by pressing a button next to it. They were also equipped with an interlock that prevent passengers from getting trapped in the door while getting off the tram. And most of GT6 windows could be opened slightly. The driver's cabin was separated from the passengers' area in Szczecin.

Helmut, as GT6 tram-cars were called in Szczecin, made terrible start in the new environment. The first run to be made by a Helmut was leading along route 3. So, a GT6 left the Pogodno depot and began to move towards the Arkonski Forest . Well, it didn't make it to the Rodla Square, as the redundancy switch was blown due to high voltage of the electric traction. At dawn, the time when few trams were still running, a substation provided current with the approx. voltage of 730 V instead of 600 V. A car that had been so carefully adjusted by Germans simply had to yield. Helmut was housed at the Niemierzyn and Golecino depots..

Helmut was removed from the public transport network mainly because there were no matching spare parts available. In 2007 there were still 11 out of 31 tram-cars running. A decision was made at that point to purchase T6A2D trams in Berlin.

Nowadays, there is a museum, Museum of Technology and Transport, where we can find some types of trams. Some examples are as follows:

1. Tram-car Bremen nº 144

Bremen was carrying passengers in Szczecin for 41 years. It always moved under the number of 144, the one it was labelled with in 1926. In 1967 it was turned into a technical support vehicle at the Regional Public Transport Enterprise and accommodated at the Pogodno depot subsequently. This Bremen was carrying tech support crews until 1995. That year it was recognized as a historical vehicle; nonetheless, it had not been renovated until 2001.



Museum of technology Szczecin.
Source: author

Technical data:

- Drive: two 45 kW electrical engines
- Seats: 24
- Standing places: 23
- Manufacture date 1926

2. Tram-car Bremen



Museum of technology Szczecin.
Source: author

After carrying passengers for 40 years, the presented tram-car was converted into a salt spreader. It consists of two platforms and technical compartment with a salt mill. The salt spreader was used together with a snow cutter. A tram-car with a snow cutter, a former Bremen car as well, is exhibited next.

Technical data:

- Drive: two 45kW electrical engines
- Manufacture date: 1926

3. Tram-car Nk nº 114

Those tram-cars, known as Nk cars, were manufactured in Chorzow in the 1950's. This used to carry Szczecin residents from May 1967 to August 1996 as the number 114 tram. Before that it had been running in Warsaw. In 2004 and 2005 it could be seen in the streets of Szczecin as a sand car. Eventually, it was removed from the tracks altogether after its electrical system had



Museum of technology Szczecin.
Source: author

burnt. The car was left at the Pogodno depot and served as a source of spare parts. It lost most of its seats, some parts of its interlocking frame and the pantograph.

Technical data:

- Drive: two 60 kW engines
- Carrying capacity: 16 seats and 62 standing places.
- Manufacture date: 1951

2.3 HISTORY AND EVOLUTION OF VALENCIA TRAM

The city of Valencia has had an extensive network of trams only surpassed by cities like Madrid and Barcelona. Its mixed system of urban and suburban services made possible to connect Valencia with other villages nearby.

The story of Valencia tramway begins in 1874 when the first tram of animal traction began to be built by Romulo Zaragoza Muela.



Old Valencia tramway.

Source: juanansoler.blogspot.com

In 1876 the first Valencia tram line was inaugurated becoming one of the first Spanish cities to introduce this system after Madrid (1871) and Barcelona (1872) This Valencia tram line disappeared in 1970.

On January 17, 1892 was inaugurates the first steam tram line. This new type of vehicle caused a large number of fatal accidents. Collisions, derailments were common and people started to call the tram "Ravachol" which was a famous French anarchist known for his macabre acts of murder.



Tramway accident in Valencia.

Source: juanansoler.blogspot.com

The first electric tram began to circulate 1900 and 1913 were already circulating around 37 units of this type.

In the postwar period the appeared another tram model with automatic doors that would not allow to access the people to it when it was in motion.

In 1970 the Valencian Association Of Trams decided that the tram was not modern and functional anymore, so they were removed. To replace them they introduced the trolleybuses, an electric bus.

The Valencia tram ceased to exist for a short period of time; only until 1994 when modern line 4 was inaugurated



New line 4.

Source: juanansoler.blogspot.com

CHAPTER 3:
URBAN CONTEXT

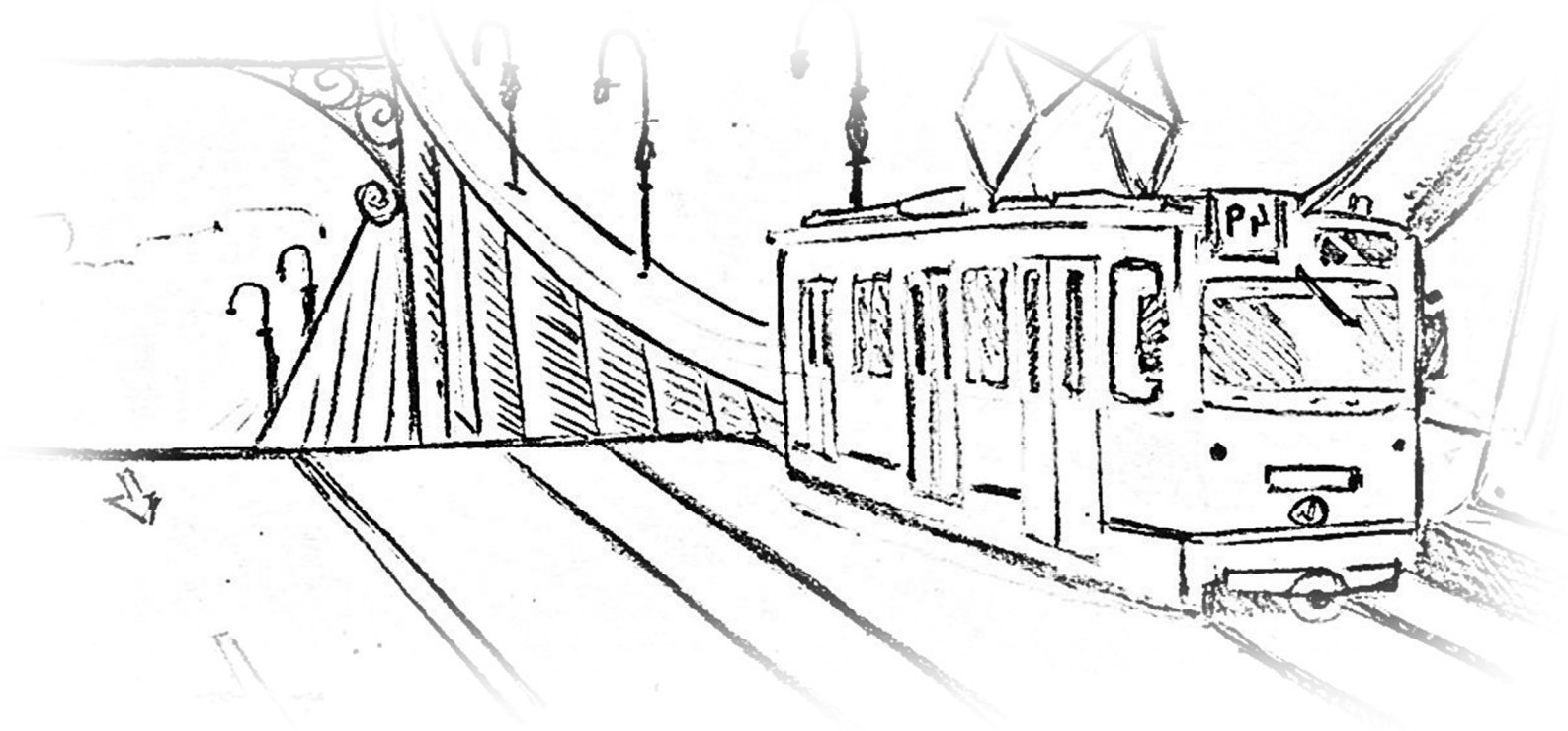

3.1 COVERAGE OF THE TRAM ACCORDING TO ITS URBAN EVOLUTION

Like any city, Valencia and Szczecin have been subjected to urban changes due to events that have passed through the centuries. Each one of them has evolved differently, depended on the needs that have been causing.

This growth inevitably originates many displacements of people within cities for work, leisure, etc. So the need for the implementation of public transport, such as trams, is increasingly important since they are a link between all points in the city where it will implant. Therefore, the development of public transport in one city is given, in part, urban's growth to the city.

As for Valencia, urban development differs in three parts: the old town, widening and periphery.

The old town

It is the part of the city urbanized since its origin until the mid-19th century urban growth. The area was surrounded by a wall whose functions were defensive, fiscal and health. At present, some of its doors as well as pieces from the wall are preserved.

Due to this wall, the old town has a compact frame, since people grew within the wall enclosure.

At first the buildings were low rise and then begins a gradual integration of buildings vertically.

Monuments such as the cathedral, palaces and churches from different periods are persevered.



Source. Font: www.guiaxvalencia.com

Widening

In the mid-19th century, urban area was expanded by the growth of the city and causes, among others, were agricultural prosperity, a process of industrialisation and an important revolution of transport.

To carry out this extension, existing walls were demolished and instead created an outside round becoming main street.

The expansion was carried out in two phases, the bourgeois expansion and the second expansion.

Buildings that were built were small houses of poor quality materials, so they deteriorated soon.

In addition, urban development led to annexing neighbourhoods and nearby towns that were differentiated from the city at that time. Now this neighbourhoods and villages are integrated in the urban area.

Periphery

The growth of industry, services and urbanization, caused a vast periphery in the second half of the 20th century. The main axes of urban growth were, on the one hand, south of the city, because of a new artificial course of the River Turia, which skirted the city to the West and South.

On the other hand the North of the city, as the old bed of the river became a large green area. On the left bank of the old river new facilities were created, as the campus.

Finally, the harbour has been fully integrated in the city.



Port of Valencia. Source:
www.oconowoc.com

As Valencia evolving urban, also evolves in terms of public transport, in order to obtain a connection between each of the points of the city. Valencia in particular has good bus connections, however, the existing tram and underground nets are scarce.

In attachments maps shows the coverage of the nets, both tram and underground. The plan divides the city by areas (Z1, Z2, Z3 and outdoor areas).

The area "Z1" covers the old town of Valencia. As you can see, the oldest area, located near the River, has no connections with these nets. This is because this part of the city is very irregular, the presence of old buildings, existence of very high water table due to the existence of ditches, etc.

As for "Z2" area, is where most connections covers, both tram and underground, especially in the north.

The area "Z3" covers area outside Valencia as well as nearby towns to the city. This area is very low in trams or underground in some areas, such as South or East.

Finally, the outer areas which connect through the underground, Valencia with towns further away from the city, even to Villanueva de Castellón, located 55.3 km from the city. In these areas there isn't tram net.

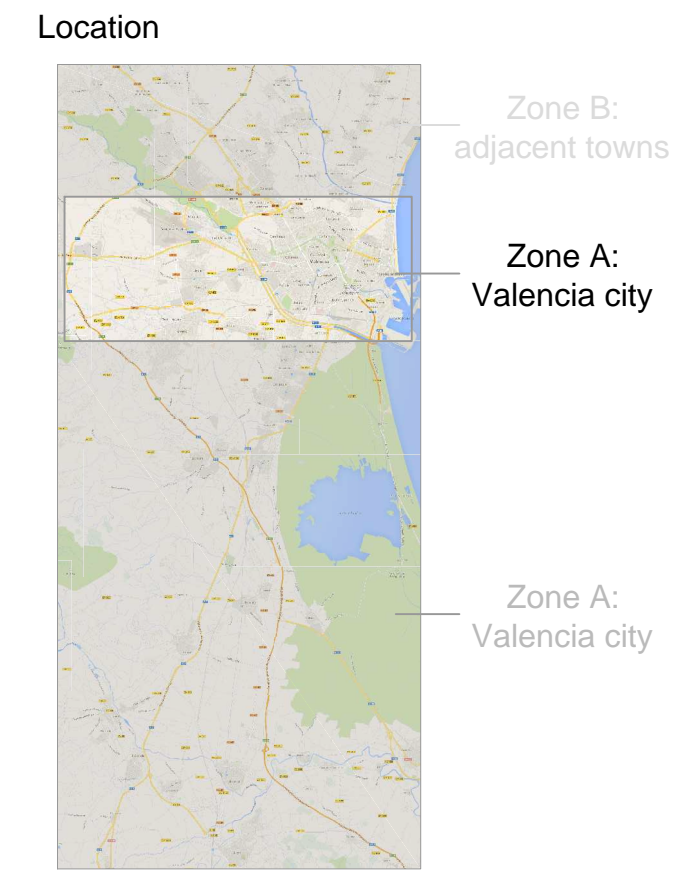
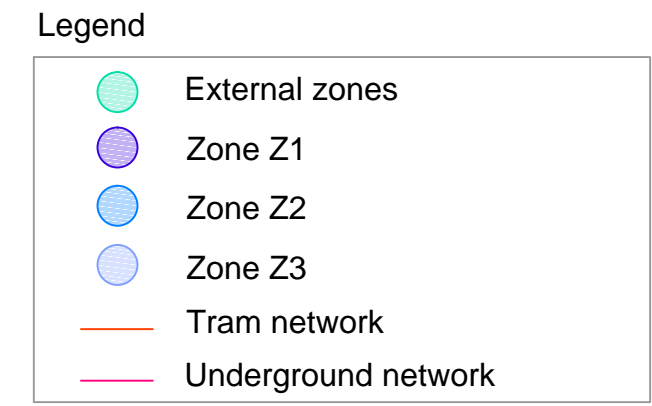
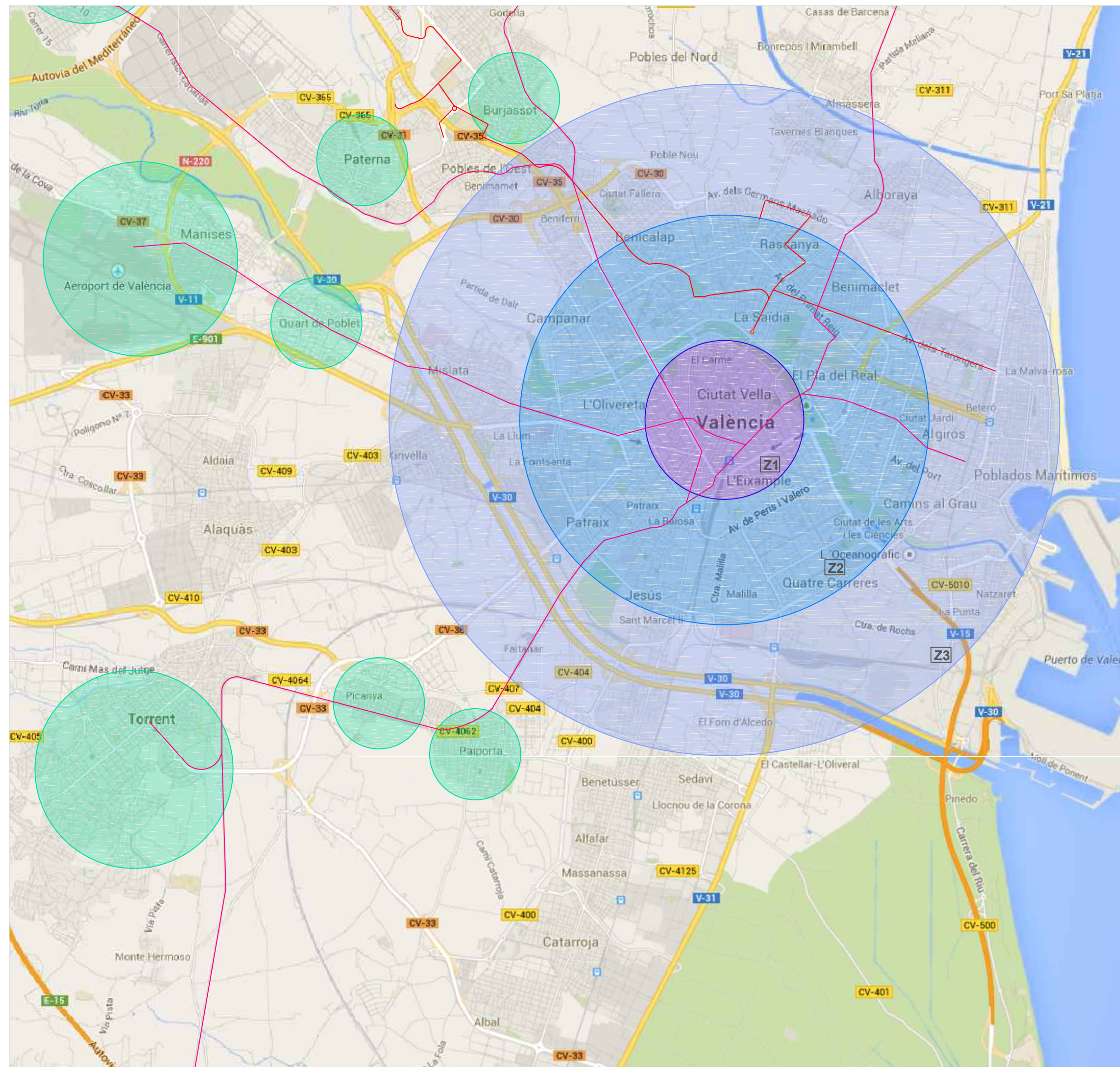

Final Project: comparative study between Szczecin and Valencia for the construction of the tramway infrastructure		
Title of plane: Coverage of the tram according to its urban evolution		
Authors: PÉREZ TOMÀS, Tania TAMARIT LATRE, Irene	Course: 2013 - 2014	
Scale: $\frac{1}{55.000}$	Situation: Valencia	Nº of plane: 1

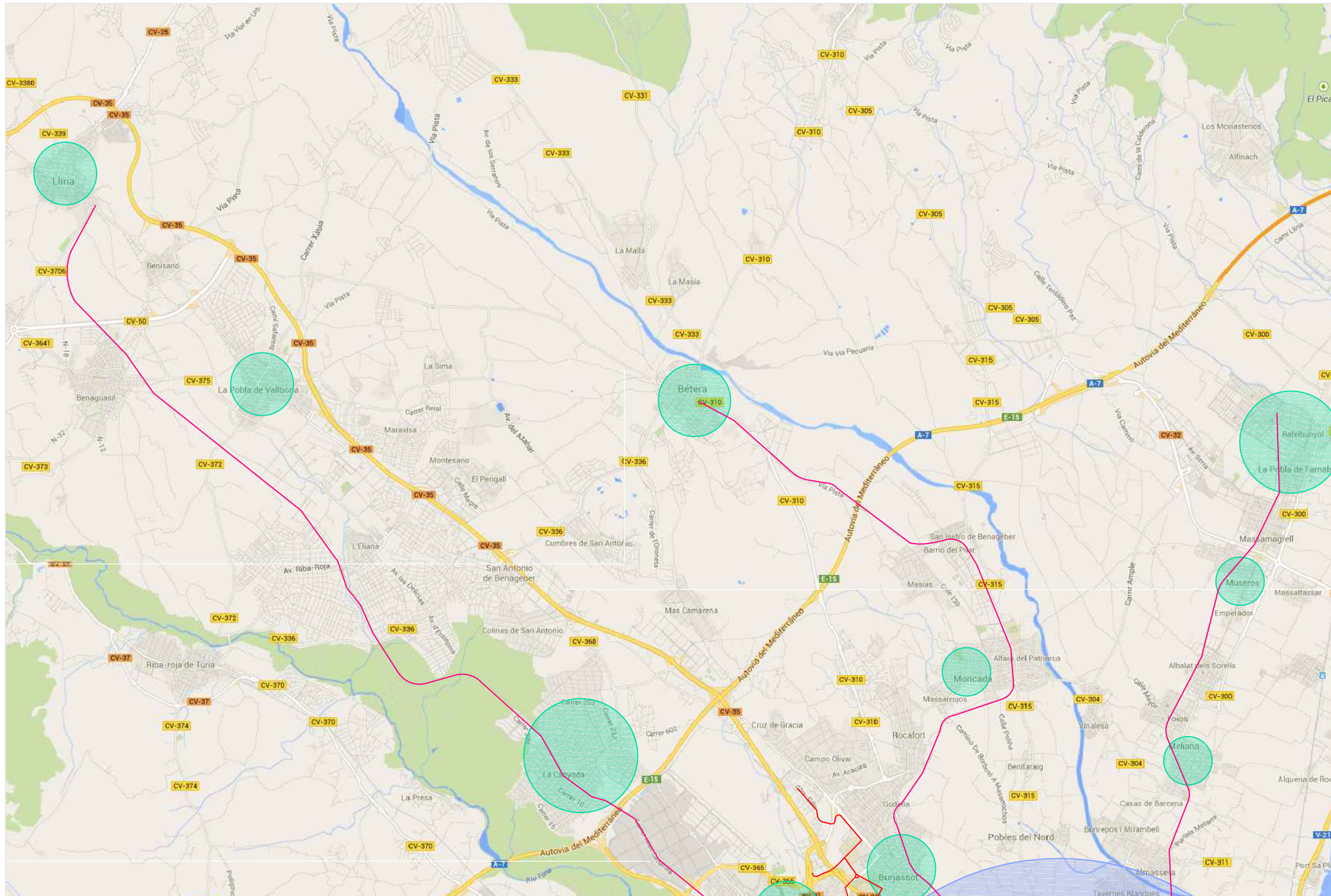

Legend

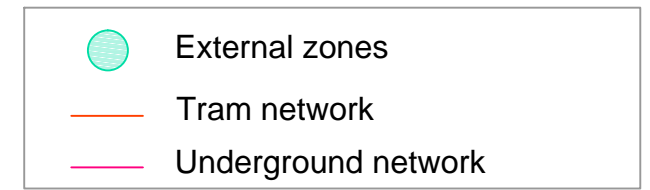

Location

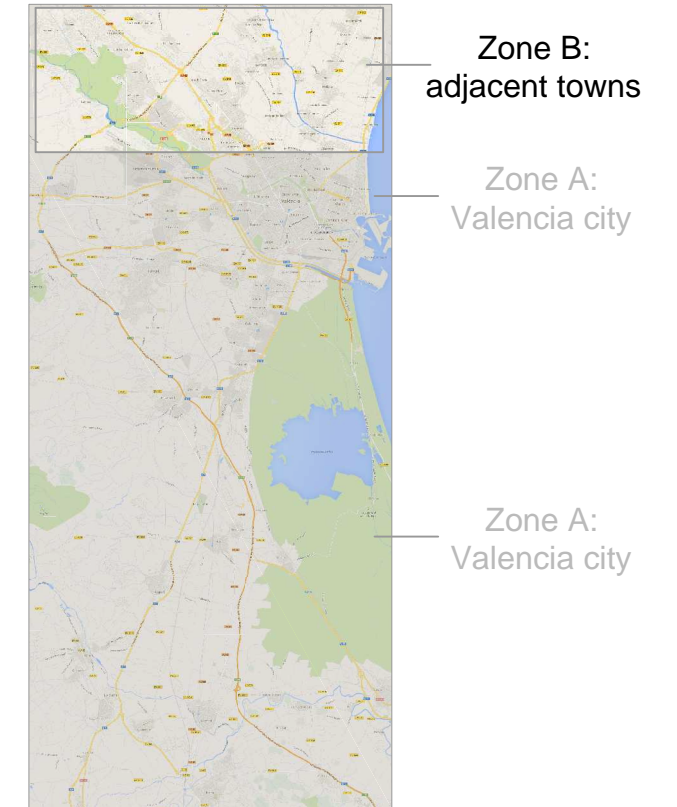

Final Project: comparative study between Szczecin and Valencia for the construction of the tramway infrastructure

Title of plane:
Coverage of the tram according to its urban evolution

Authors: PÉREZ TOMÀS, Tania
TAMARIT LATRE, Irene

Course:
2013 - 2014

Scale: 1

Situation:
Valencia

Nº of plane:
2

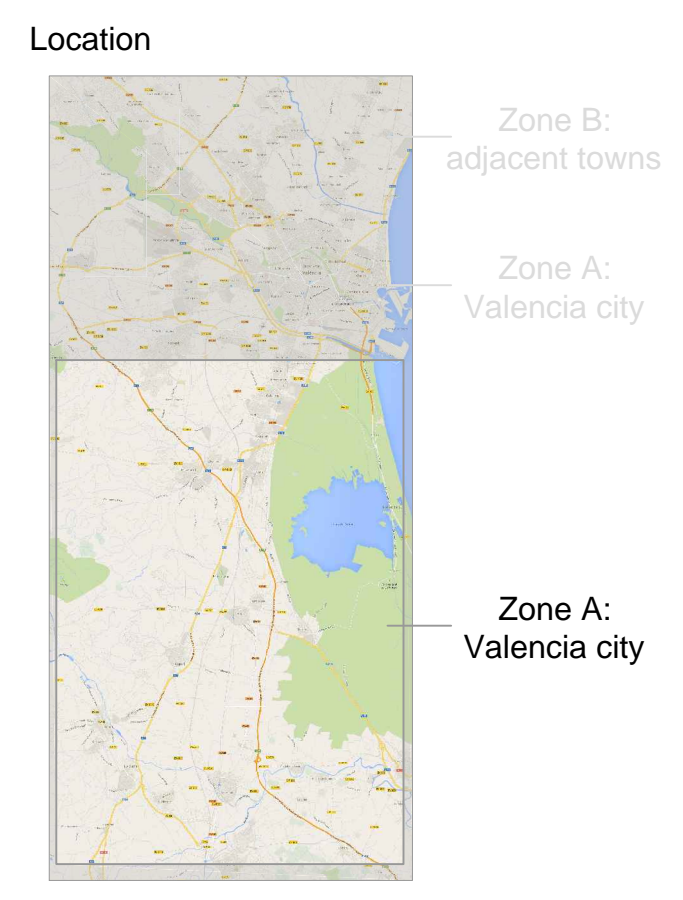
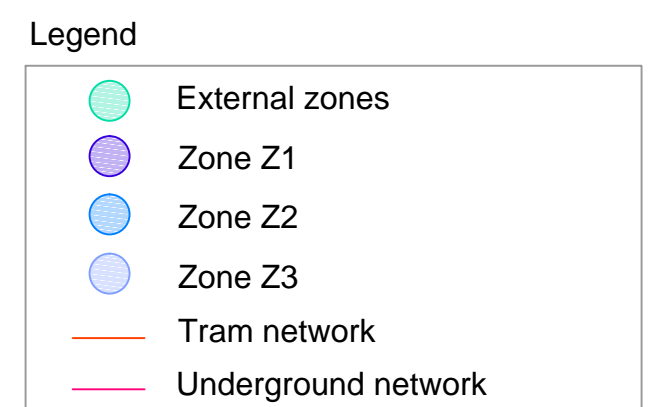
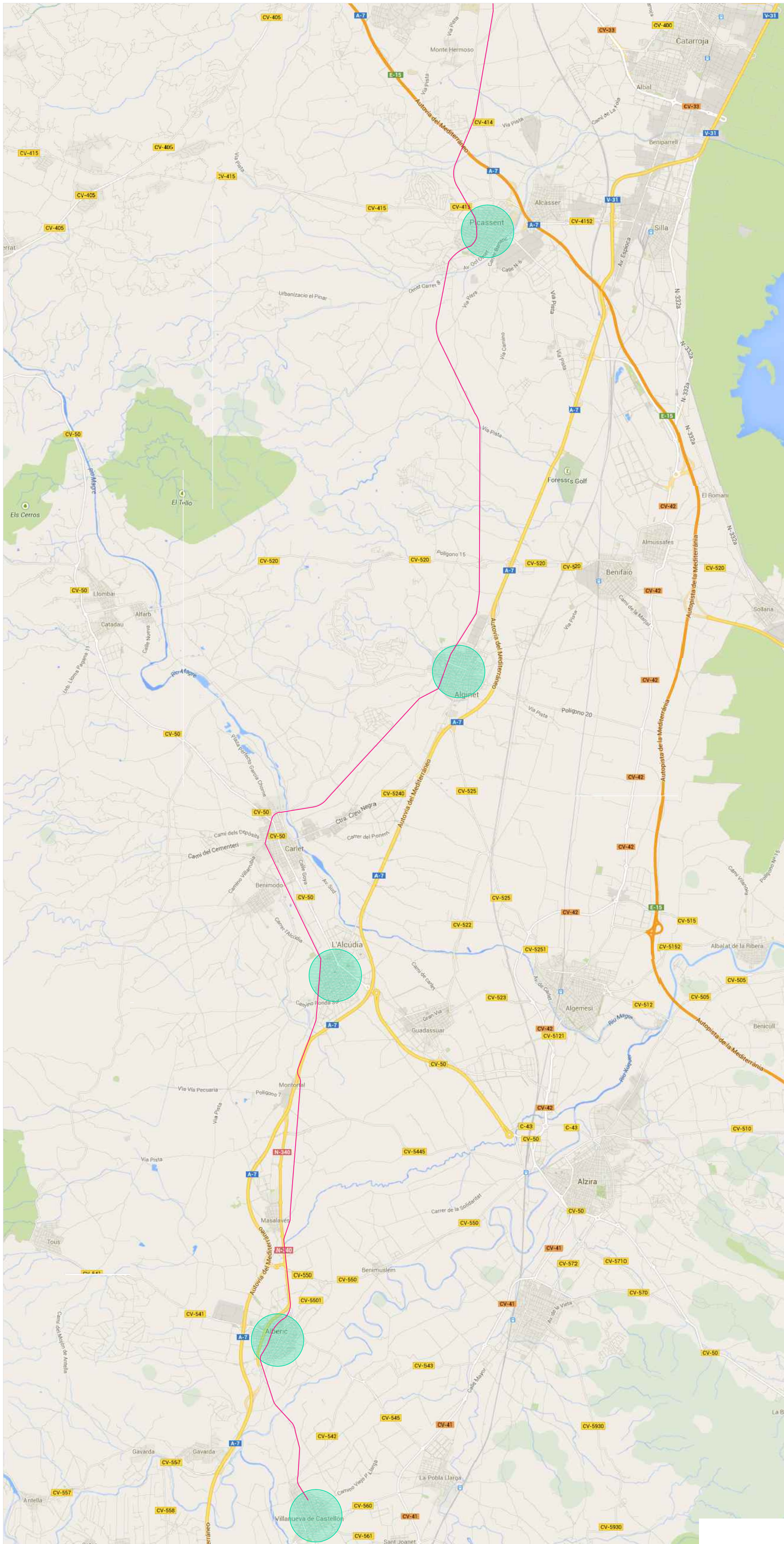

Final Project: comparative study between Szczecin and Valencia for the construction of the tramway infrastructure		
Title of plane: Coverage of the tram according to its urban evolution		
Authors: PÉREZ TOMÁS, Tania TAMARIT LATRE, Irene	Course: 2013 - 2014	
Scale: $\frac{1}{55.000}$	Situation: Valencia	Nº of plane: 3

As you can see on the maps, there are areas of Valencia, both in the city and around the presence of a tram or underground net is zero.

As mentioned previously, the construction of a net of underground and tram in the historical centre of the city is an impossible task for which the connections in that area of the city are better by bus.

However there are parts of the city where it is possible to build a tram net. Those spaces are reflected in the next map where possible tram nets that can be built, both in the city and in the near towns, in order to have a broader connection between all parts of the city, both inside and outside.



In the area "Z4", as shown in the plan, there is a net in construction, called line 2 which are available from the center of the city with the port of Valencia, although he has been paralyzed for a time due to economic problems.

As noted in previous plans, the villages around Valencia are well connected to the city, either by underground, by tram or even trains, however there is an area "Z5", in which nearby villages do not have any connection with the city, so the construction of a underground or tram line in that area would be very functional, as it would facilitate the arrival of people from that area to Valencia.

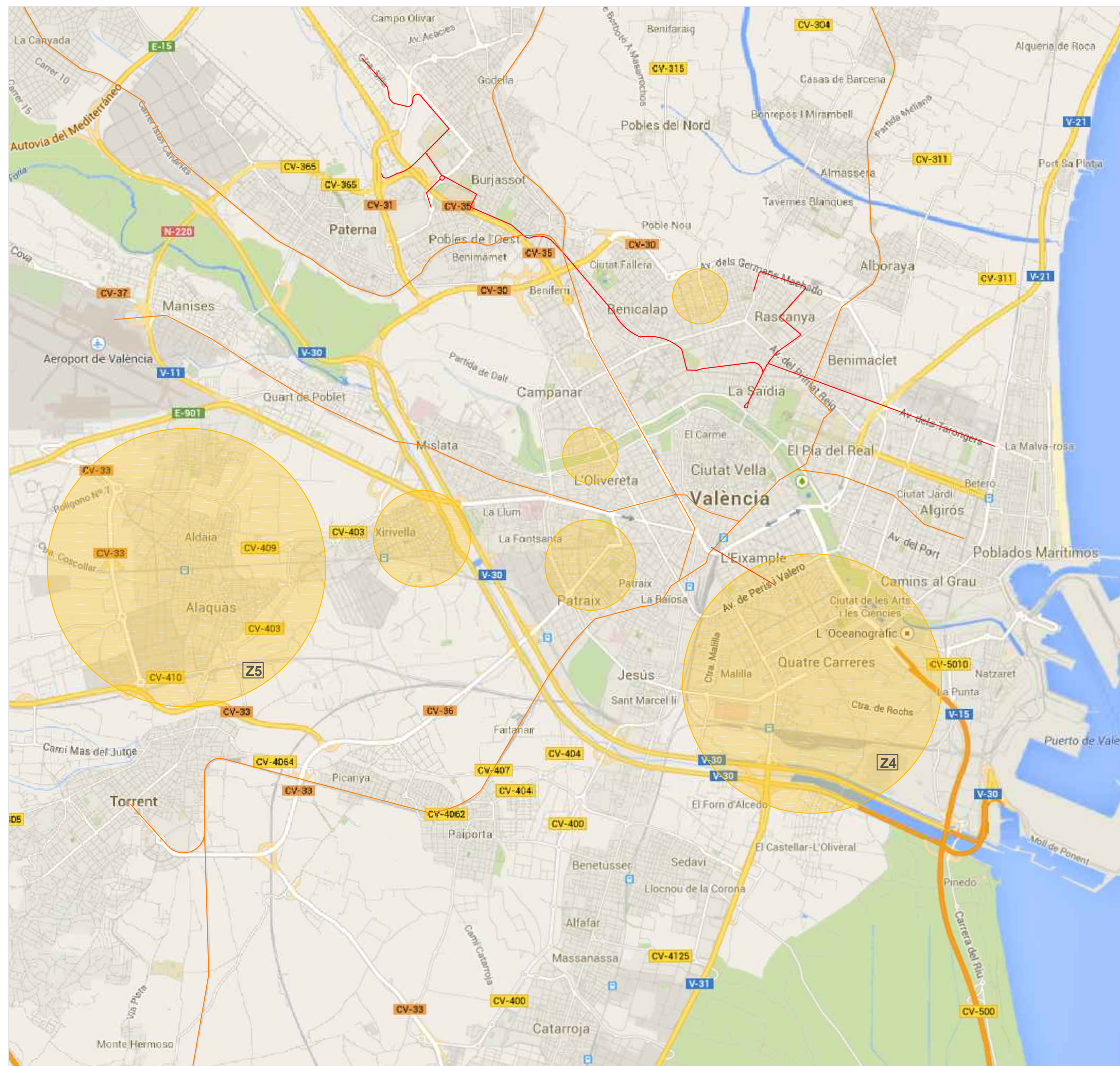
Last but not least, there are also areas in Valencia where they could extend the lines as their presence therein is void and can only be accessible by bus or public transport.



Legend

-  External zones
-  Tram network
-  Underground network

Location

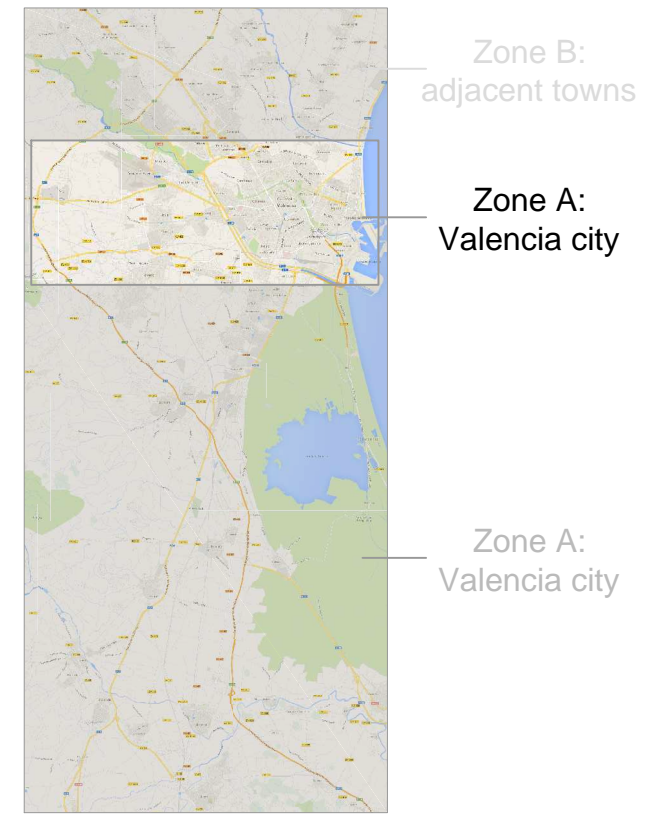

Final Project: comparative study between Szczecin and Valencia for the construction of the tramway infrastructure		
Title of plane: Coverage of the tram according to its urban evolution		
Authors: PÉREZ TOMÀS, Tania TAMARIT LATRE, Irene	Course: 2013 - 2014	
Scale: <u> 1 </u>	Situation: Valencia	Nº of plane: 4

On the other hand, Szczecin urban development can be divided into three parts: the old town, expansion and industrial area.

Old town

Like Valencia, Szczecin has its historic old-town next to the bed of the river. It is part of the urbanized city that which surrounded by a wall, called Old Town. In Szczecin also preserved some of the doors of that wall.



Szczecin. Source: Book. 50 Jahre Stettiner
strassenbahn 1879-1929

In 1945, the city was bombed and destroyed 90% of the old city, although some historic buildings survived.

The architectural style of the historic center is due to trends popular in the latter half of the 19th century and early 20th century, Academic art and Art Nouveau.

The Old Town was rebuilt in the late 1990s, consisting of new buildings, some of which were reconstructions of buildings destroyed in World War II. In this area of the city we can find the most important monuments of the city such as the Cathedral, the castle of the Dukes of Pomerania or Old Town Hall.

The Old Town was rebuilt in the late 1990s, consisting of new buildings, some of which were reconstructions of buildings destroyed in World War II. In this area of the city we can find the most important monuments of the city such as the Cathedral, the castle of the Dukes of Pomerania or Old Town Hall.

Expansion

In the expansion of the city there are many green areas, parks or trees planted on the islands of the streets that separate opposing traffic, also there are many roundabouts. This is because Szczecin was redesigned in 1880 by Georges-Eugène Haussmann, who had redesigned Paris also. At present, the design of city streets continues to be used.



Szczecin. Source: ds-lands.com

During the reconstruction of the city in the aftermath of the Second World War II, the communist authorities of Poland wanted that the city architecture reflect an old Polish Piast era. Since there were no buildings of the time, it was decided to maintain the Renaissance and Gothic buildings.

Industrial zone

It is the area on the right side of the river. In this area most of the industries belonging to Szczecin are located.

Szczecin has evolved in an urban way, but also has been expanding and improving the net of trams, unlike Valencia, the network is much more complete. In addition, it should be noted that not only has good tram net, but also has a large net of bus lines, which are complemented with trams to connect the city completely.

In the next map you can see the existing nets of trams in the city, as well a division for areas of the city (Z1, Z2, Z3 and outdoor areas).

The area "Z1" covers the old town of Szczecin. As can be see, the oldest area, next to the River, has very good connections with the tram net, so get to the city centre is easy.

On the other hand, the "Z2" area is an extension of the urban area to the left side of the river. This area is also well connected to the net.

The outdoor areas, also part of Szczecin, but are like concentrated neighbourhoods. As the plane reflected tram net connects the Centre of the city with the majority of those districts, although there are some of them which can only be reached by bus.

Also keep in mind the area to the other side of the river (Z3), which is the industrial area of Szczecin. It is also connected to the city by tram. The last stop on the line there are connections with many buses to reach more remote areas of Szczecin, although it takes too much time to reach them. So there is an ongoing "Fast Tram" project, which you will arrive as soon as possible from one side of town to the other.

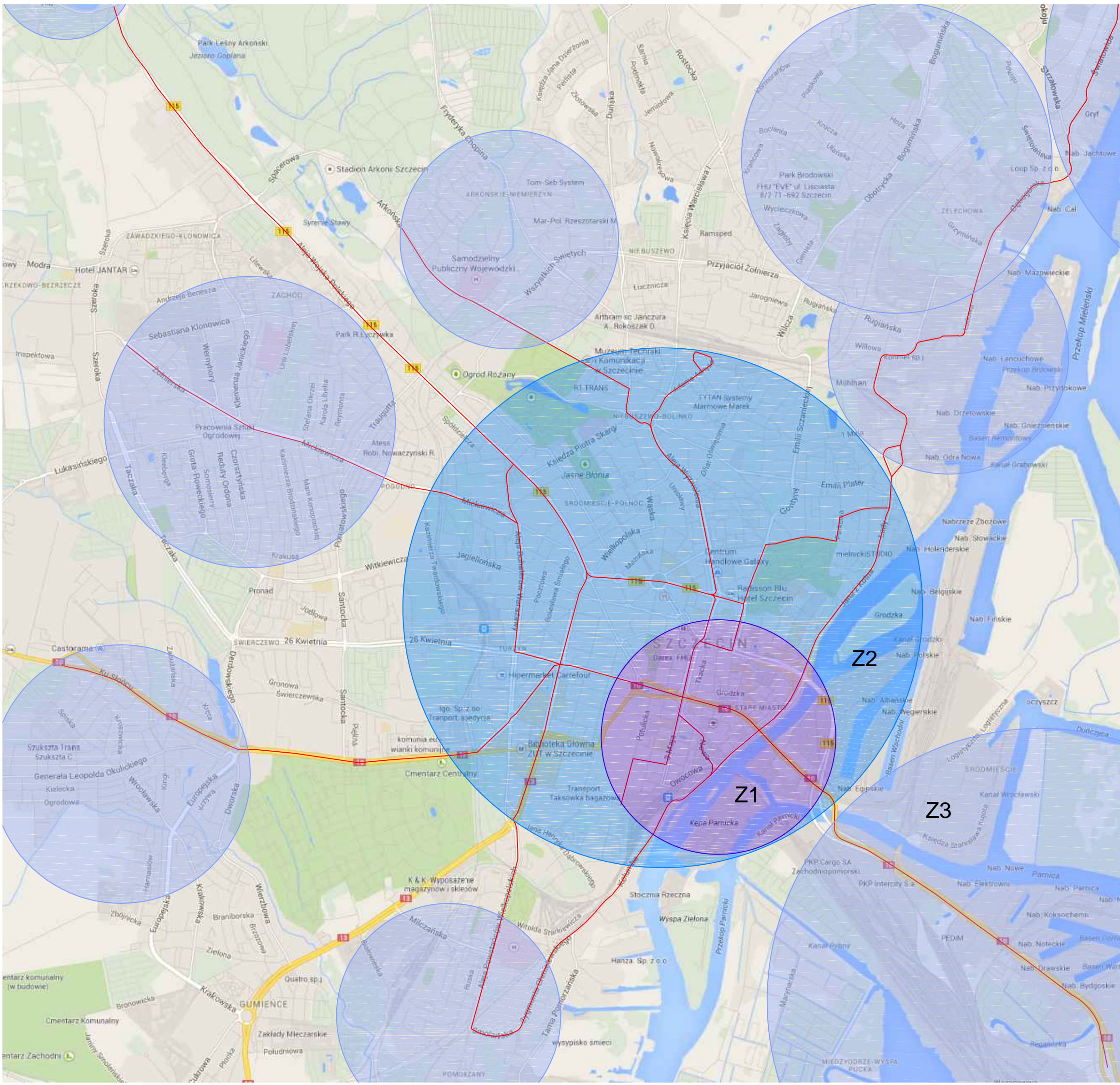

Legend

- External zones
- Zone Z1
- Zone Z2
- Zone Z3
- Tram network

Final Project: comparative study between Szczecin and Valencia for the construction of the tramway infrastructure		
Title of plane: Coverage of the tram according to its urban evolution		
Authors: PÉREZ TOMÀS, Tania TAMARIT LATRE, Irene	Course: 2013 - 2014	
Scale: <u> 1 </u>	Situation: Szczecin	Nº of plane: 5

On the next map we can be clearly seen the zones where the tram network does not cover. There are three neighbourhoods on the outskirts of Szczecin, two to northern and one to southern where it would be useful to construct or expand the existing tram line for connect these districts with city center.

Buses network in Szczecin is more extensive than the tram lines and it covers the city center and remote areas of the city where the tramway doesn't go.

Nonetheless there are still problems with public transport in Szczecin; the continuing city development, new dwelling districts on the right and left of the Odra River and dynamic development of motoring industry generate an immediate necessity of transport.

Therefore it has been decided to construct the Szczecin Fast Tram will finally start after many preparations. The city has signed a subsidy contract for this investment.

In 2015 Szczecin's residents will be able to use the new connection between the right and the left side of the city. It's a milestone in the development of Szczecin public transport. The investment has been prepared for years.

It includes the construction of Szczecin Fast Tram which will be 4 Km long. Railways, modern loops and stops will be built as well.

The 4 Km extension will start at Basen Górniczy on the east side of the River Odra and run to Truskawkowa with three intermediate stops. The fully segregated line will use a bridge over the River Regalica that was built in 1999-2003 with provision for a double track alignment.

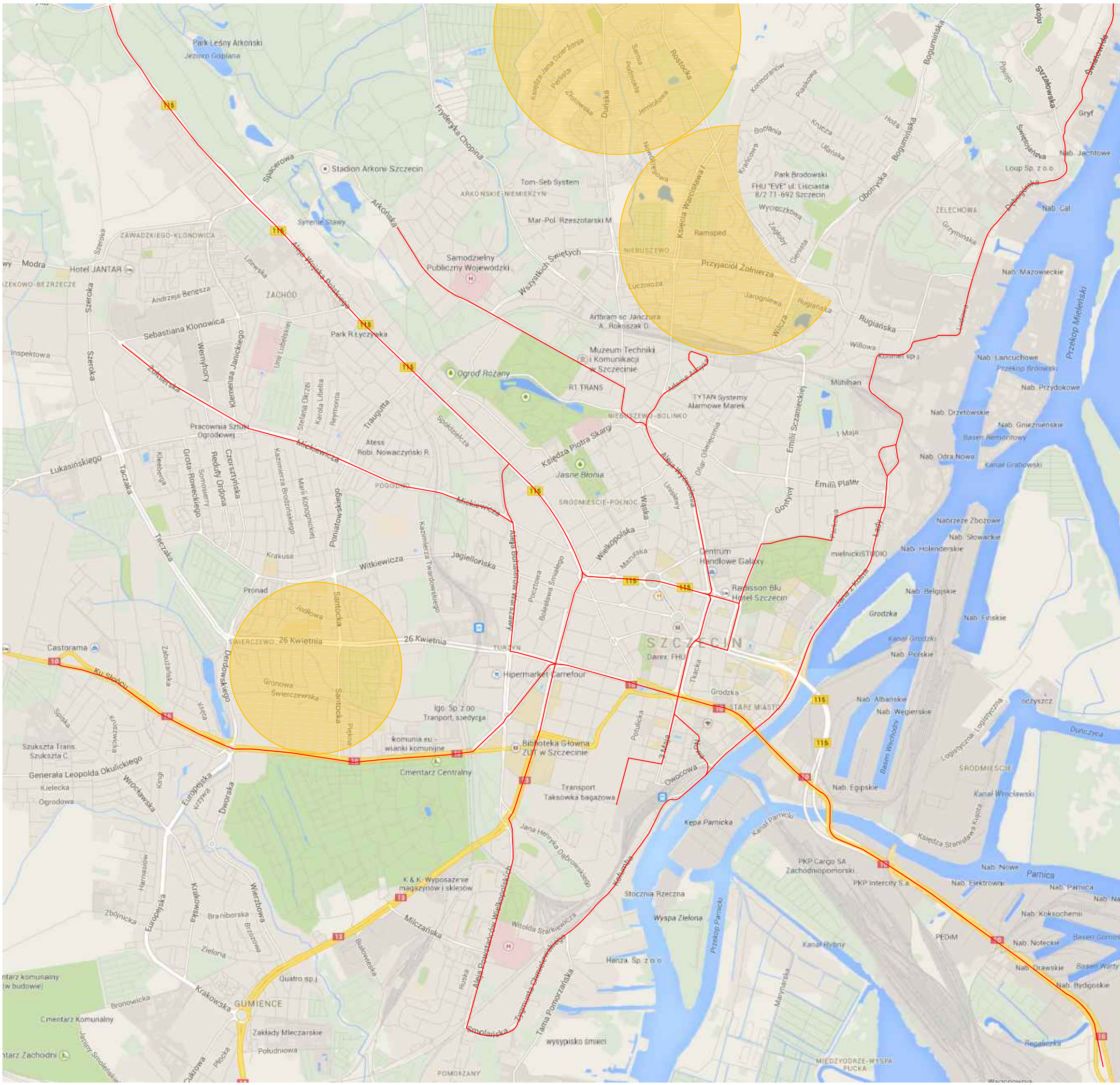

Legend

- External zones
- Zone Z1
- Zone Z2
- Zone Z3
- Zone Z3
- Tram network

Final Project: comparative study between Szczecin and Valencia for the construction of the tramway infrastructure		
Title of plane: Coverage of the tram according to its urban evolution		
Authors: PÉREZ TOMÀS, Tania TAMARIT LATRE, Irene	Course: 2013 - 2014	
Scale: <u> 1 </u>	Situation: Szczecin	Nº of plane: 6

3.2 RED TRAM: COMPARISON OF SZCZECIN AND VALENCIA

Following there are two planes one the network of tram of Szczecin and the other to the underground network and Valencia tram. In them is reflected all destinations, as well as points of interest of both cities.

The Valencia's network has 5 existing lines, only two of them are tram network and as mentioned above there is an underground line in construction.

Lines concerning the underground are line 1, 3 and 5. As its name indicates, these lines go by the subsoil of the city, although some points, which are already situated outside the city, lines up outside. These lines connect many points of the city and with the most nearby towns, even reaching towns with a distance of approx. 55 km from Valencia, as the case of line is 1, which connects the city center with Villanueva de Castellón.



Underground of Valencia.
Source: noticias.lainformacion.com

These lines also connect with very important points of the city such as the city airport (lines 3 and 5), both the train station and the AVE (line 5), as well as the University CEU (line 1) or some faculties of the University of Valencia and the hospital Clínico (line 3).

Underground lines are also connected to each other; on the map you can see all existing connection points. But not only these points are used to connect several underground lines, but in some points, as the case of Empalme or Benimaclet stop, where the underground network connects with the tram.



Tram of Valencia. Source: www.lovevalencia.com

As for the tram networks in Valencia there are only two lines (lines 4 and 6) both are connected in Primate Reig stop. These connect a small part of the city, although the line 4 also comes very close to several towns in Valencia, such as Burjassot.

Through them we can reach the major city points, such as the campus Tarongers and Universidad Politecnica de Valencia (both lines) and campus Burjassot (line 4). Also by line 4

can reach the *Fira de Valencia*, in which are many exhibitions and exhibitions of tourism, construction, etc..

On the other hand, Szczecin has 12 tram lines. Tram network of this city is very complete, and you can reach any point in the city by tram. It is interesting to know that today is building a line called Fast Tram, which connects the city side to side faster than existing tram lines.

The network connects points of interest such as the cemetery which is one of the largest in Europe (line 8 and 10) and two hospitals (by line 3 can reach both).

Also from the educational point of view, by tram you can reach several universities in the city such as the xxx by lines 11 and 12.

Like Valencia, Szczecin also has many transfer stations, such as Brama Portowa station, so it makes the flow of people through the city much easier.

In conclusion, despite Szczecin is smaller in area and population, this will have a more developed and comprehensive tram network.

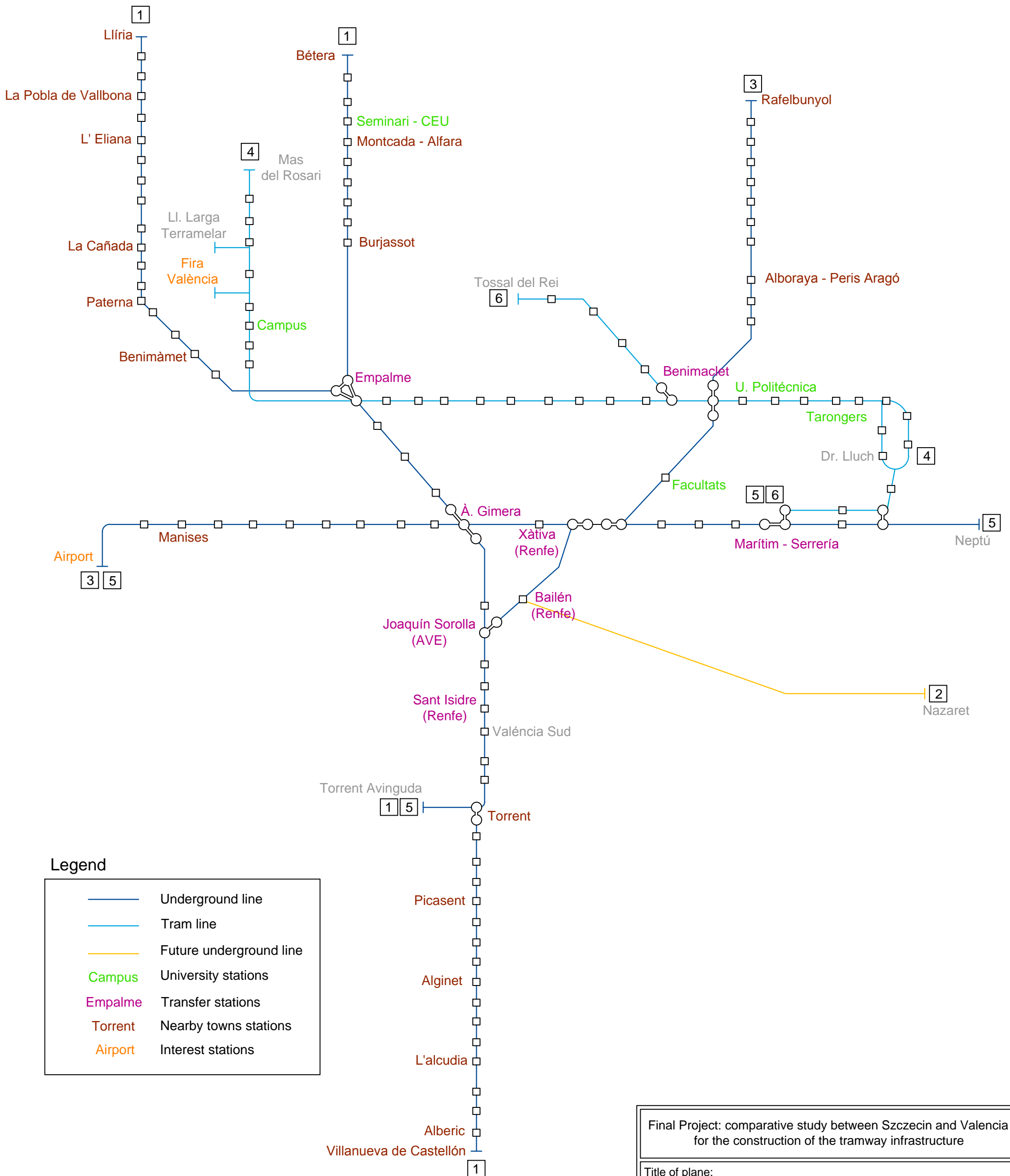



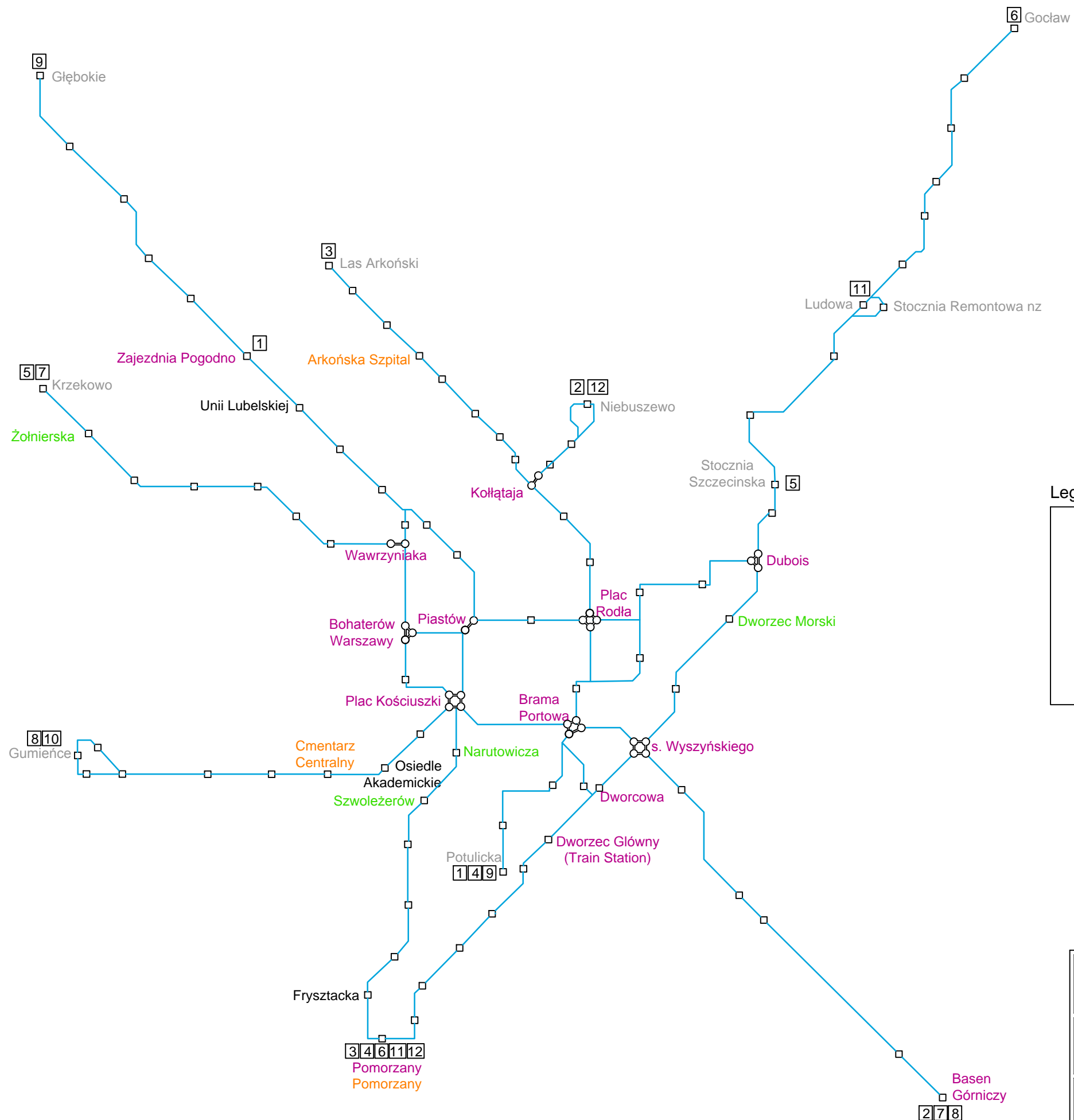

Legend

	Underground line
	Tram line
	Future underground line
	University stations
	Transfer stations
	Nearby towns stations
	Interest stations

Final Project: comparative study between Szczecin and Valencia for the construction of the tramway infrastructure		
Title of plane: Tram net of Valencia		
Authors: PÉREZ TOMÀS, Tania TAMARIT LATRE, Irene	Course: 2013 - 2014	
Scale: —	Situation: Valencia	Nº of plane: 7



Legend

	Tram line
	University stations
	Transfer stations
	Interest stations

Final Project: comparative study between Szczecin and Valencia for the construction of the tramway infrastructure

Title of plane:
Tram net of Szczecin

Authors: PÉREZ TOMÀS, Tania
TAMARIT LATRE, Irene

Course:
2013 - 2014

Scale:
—

Situation:
Szczecin

Nº of plane:
8

3.3 ECONOMIC – SOCIAL CONTEXT

VALENCIA

- POPULATION: 794228 people
- AREA: 528.81 Km²

	COMPANY	PRICES	€	zł	FREQUENCY	Nº LINES	HORARY
SUBWAY- TRAM	Metrovalencia	Single ticket	1.5	6.3	☀️ 10-20 min	5 lines	5:00-23:00
		Ticket 10trips	7	29.4			
		Monthly ticket	41	172			
BUS	EMTvalencia	Single ticket	1.5	6.3	☀️ 7-15 min 🌙 45 min	43 lines 13 lines	6:30-22:30 23:00-2:00
		Ticket 10trips	8	33.5			
		Monthly ticket	30	126			
BICYCLE	Valenbisi	Yearly ticket	27	111.9	-	-	24h
TAXI	Radio-taxi	☀️ 5Km	4.4	18.2	-	-	24h
		🌙 5Km	6	24.7			

NOTE 1: Prices of metro and tram correspond to zone A, with this type of ticket you can only travel around the city of Valencia.

NOTE 2: The frequencies and the horary are approximate as they depend on the number of the line.

SZCZECIN

- POPULATION: 405.944 people
- AREA: 300.06 Km²

	COMPANY	PRICES	€	zł	FREQUENCY	Nº LINES	HORARY
SUBWAY- TRAM	ZDiTM	15 min	0.5	2	⌚ 12-20min ★ 20-24min	12 lines	5:00-23:00
		30 min	0.7	3			
		1 hour	0.9	4			
BUS	ZDiTM	2 hours	1.2	5	☀️ 11-20min 🌙 1h	44 lines 14 lines	6:30-22:30 23:00-5:00
		1 day	2.9	12			
		5 days	8.5	35			
TAXI	Taxi4you	☀️ 5Km	2.4	10	-	-	24h
		🌙 5Km	3.6	15			

NOTE 1: Prices tram and bus correspond to a normal ticket, students have discounts. The prices are reduced by half.

NOTE 2: The frequencies and the horary are approximate as they depend on the number of the line.

⌚ Working day	☀️ Day-time
★ Weekend	🌙 Night-time

It's difficult to make an exhaustive comparison of all parameters listed in the tables because many of them are not measured in the same way.

This is the case of prices, in Szczecin tram and bus tickets are bought for time spent on the travel that means, you can buy tickets for thirty minutes, one hour, etc... And you can travel with this ticket doing the transhipments that you need during this time. However in Valencia, tickets spends by number of trips that you make, although, once validated the ticket you can make transhipments until after the half hour.

But considering that the prices of metro and tram on which we are comparing in Valencia correspond only to the zone A and this area covers only the center of the city, we can say that the average of journeys will be around 30 minutes. So if we compare the price of a single trip in Valencia with the price of the ticket at 30 minute in Szczecin we can observe that tram in Valencia is twice as expensive.

However, in Valencia there is a possibility to buy a 'bonometro', it's a card that accumulates trips, and usually people recharge bonometros with 10 trips. In this way the price of a single trip of metro and tram is similar to the price of Szczecin.

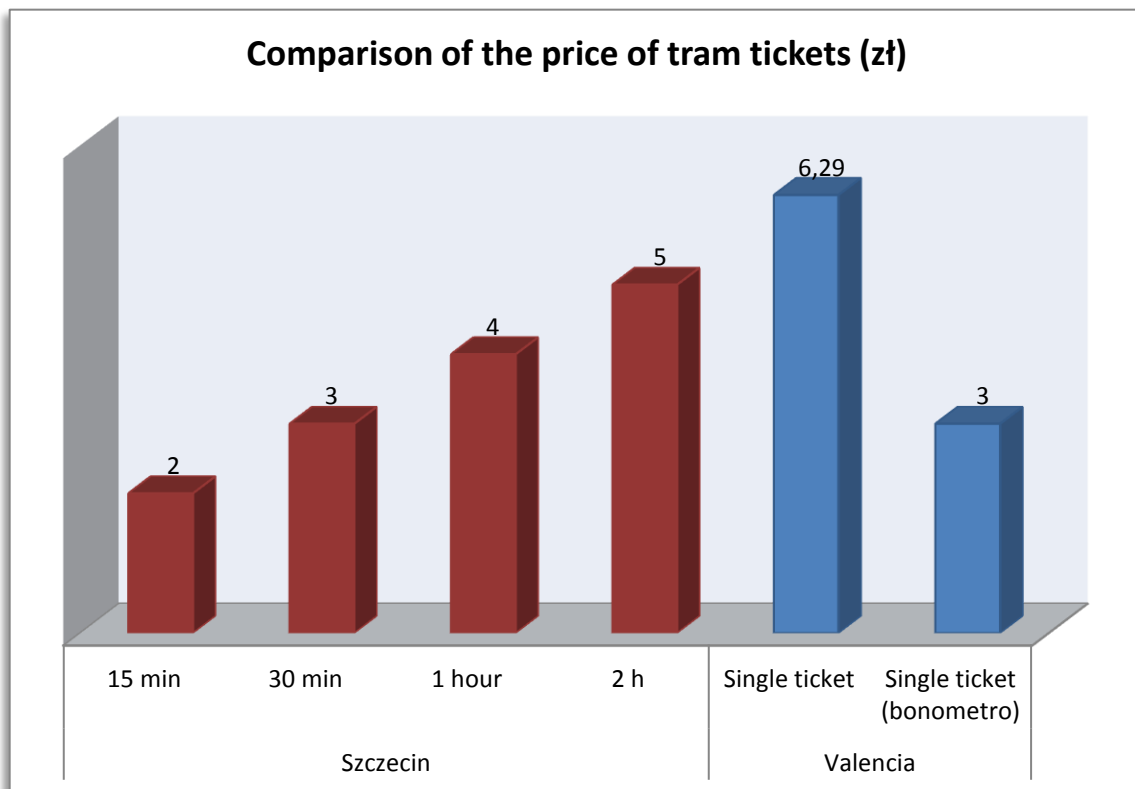

Graphic 1: Comparison between the prices of the trams tickets in Szczecin and Valencia. Source: Author

Regarding the frequency of trams with the data presented in the table can not make a reliable comparative because in both Valencia and in Szczecin, this parameter dependent on the number line bus, tram or subway that is being studied.ukhil

Although, if we make an average, the table show a slight higher tram service frequency of the Valencia public transport in buses and trams.

In neither of the two cities there are night tram lines, however, there are night buses. We can say that although the buses frequency of such lines is greater in Valencia, the horary is much more extended in Szczecin (until 5:00 am).

Daytime public transport lines have approximately the same time range (although this also depends on the line being studied).

With respect to the existing bus network, the number of operational lines in both cities is very similar. If there is a clear difference in the number of tram lines / m.

The number of tram lines in Szczecin is more than double of the existing lines in Valencia. If we also consider that population and area of Valencia is almost double that of Szczecin we can say that the Polish city offers a much better public transport.

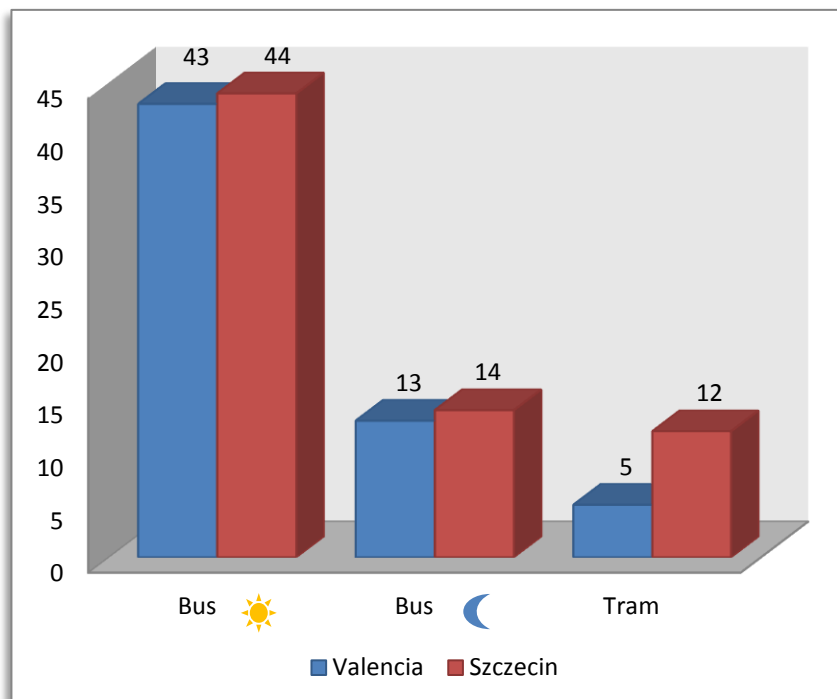

Graphic 2: Comparison between number of lines in Szczecin and Valencia

Other services that we haven't yet mentioned are the bicycle and taxi.

The bicycle is a means of transportation appropriate for the two cities because Valencia and Szczecin are quite flat and none of them is too big. Szczecin has over 40 kilometres of bike lanes, Valencia exceeds 150 Km and also has a public bike rental service called "*valenbisi*". This is a service that has 2,750 bikes distributed over 275 stations, they are located in different parts of the city. For an annual subscription you only need to register on the website and pay € 27.12, with that payment you can make an unlimited number of trips for a year.



Valenbisi service. Source:
www.lovevalencia.com

Finally we study the taxi service. Broadly we can say that in Szczecin taxis are much cheaper than in Valencia. To cover the same distance in Valencia taxi costs you twice as expensive as in Szczecin.

3.4 AREAS CHOSEN FOR THE STUDY

The zones that we were chosen for the constructive and material analysis and for observation of the conservation state in Szczecin correspond to the tram lines that runs along Piastow street and the tram lines that circulate along the Potulicka and Narutowicz street. For the Valencia analysis we were selected Tarongers avenue witch go the 4 and 6 tramline.

The areas selection in Szczecin has been conditioned by actuals reconstructions works and improvements in tramways infrastructures. Thanks to this fact we can collect data, take pictures and acquire information at first hand.



LEGEND

- Piastow Str.
- Potulicka Str.
- Narutowicz Str.

In Valencia we have decided to choose Tarongers Avenue because the service offered by the tram in that area is very important.

On this avenue there are many Universities, and tram transportation is the most used by students to go to class. In addition it is crossed by the two existing tram lines in the city that offer service to the beach, so many people uses it in summer.



LEGEND

 Tarongers Avenue

The street Aleja Piastów is one of the streets most travelled of the city. This avenue is in the expansion of the city. In this area, most of the buildings are residential buildings with ground floor commercial premises. The predominant use in this street is residential and educational.

In addition to these residential areas, there are also several areas university residences as isolated blocks with greenery around. There are also, along the street, numerous university schools. Here we can find five faculties of Zachodniopomorski Uniwersytet Technologiczny.

Actually for this street, tram number 4, 11 and 12 circulates.

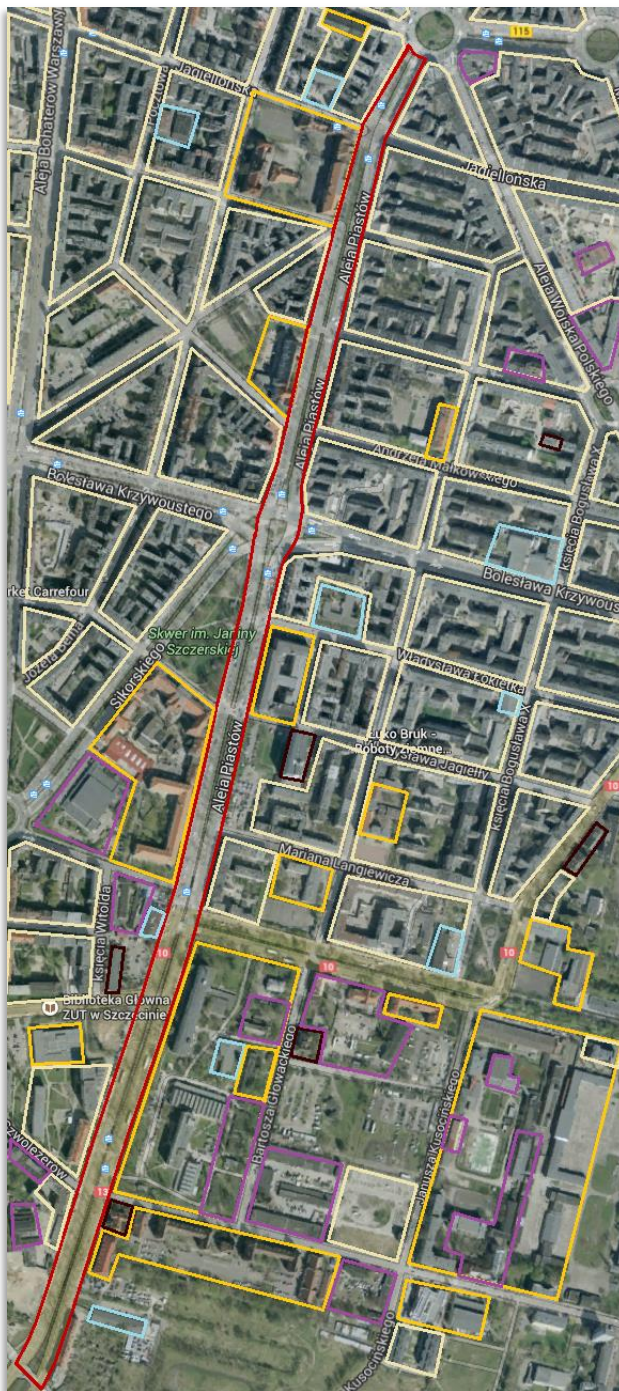

LEGEND

- Piastow Str.
- Residential
- Comercial Buildings
- Public Buildings
- Office Buildings
- No residential buildings

The Potulicka and Narutowicz street are included in the old part of Szczecin, near to the river. This zone is mainly residential use but you can also find some office buildings.

The antiquity of the area and its proximity to the river are two drawbacks to perform construction work; the possible appearance of historical remains and the presence of high water-table.

In this area go tram lines 1, 4 and 9.

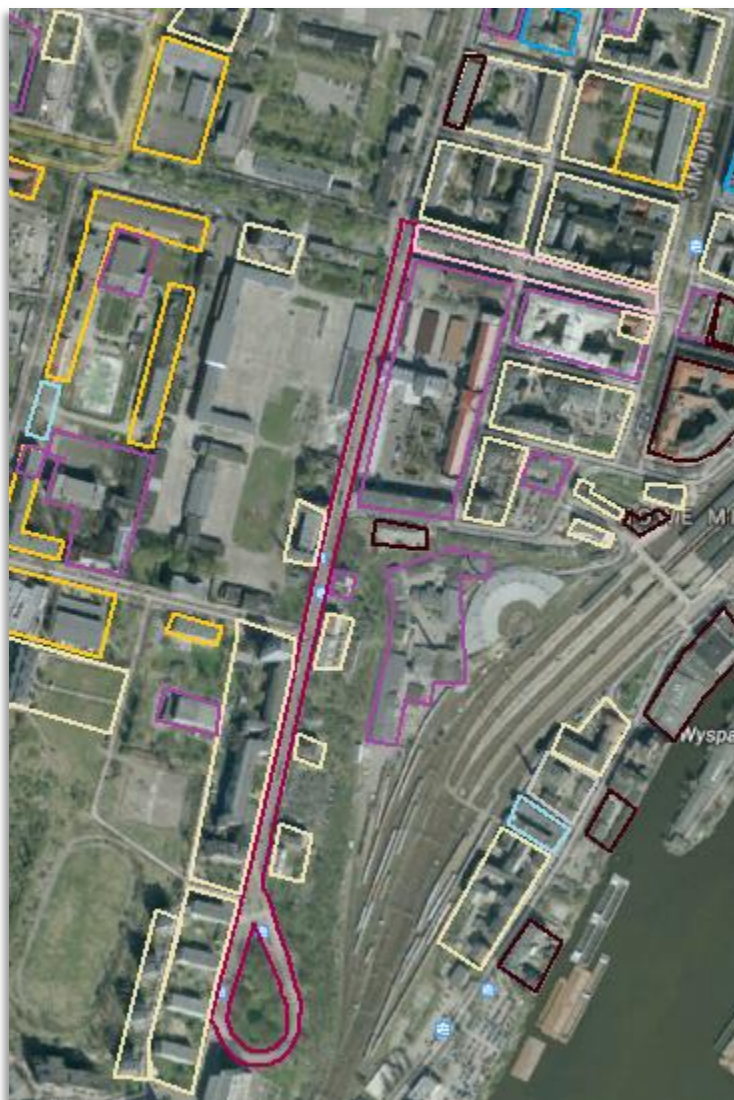

LEGEND

-  Narutowicz Str.
-  Potulicka Str.
-  Residential
-  Comercial Buildings
-  Public Buildings
-  Office Buildings
-  No residential Buildings
-  Healthcare center

Tarongers Avenue is an extension of the city designed to connect the central core of the city with the Maritime Villages.





On both sides of this avenue there are two university campuses: in the north is all faculties of Universitat Politecnica de Valencia and in the south is located, some faculties of Universitat de Valencia: teaching, social sciences, law and economics.

The last section of this road is residential, crossing the emblematic neighborhood of Cabanyal.

On Avenue Tarongers circulate two tram lines, line 4 and 6 towards the beach.



LEGEND

-  Tarongers Av.
-  Residential
-  Comercial Buildings
-  University Buildings
-  Urban services

CHAPTER 4:
STUDY AND
ARCHITECTURAL
ANALYSIS

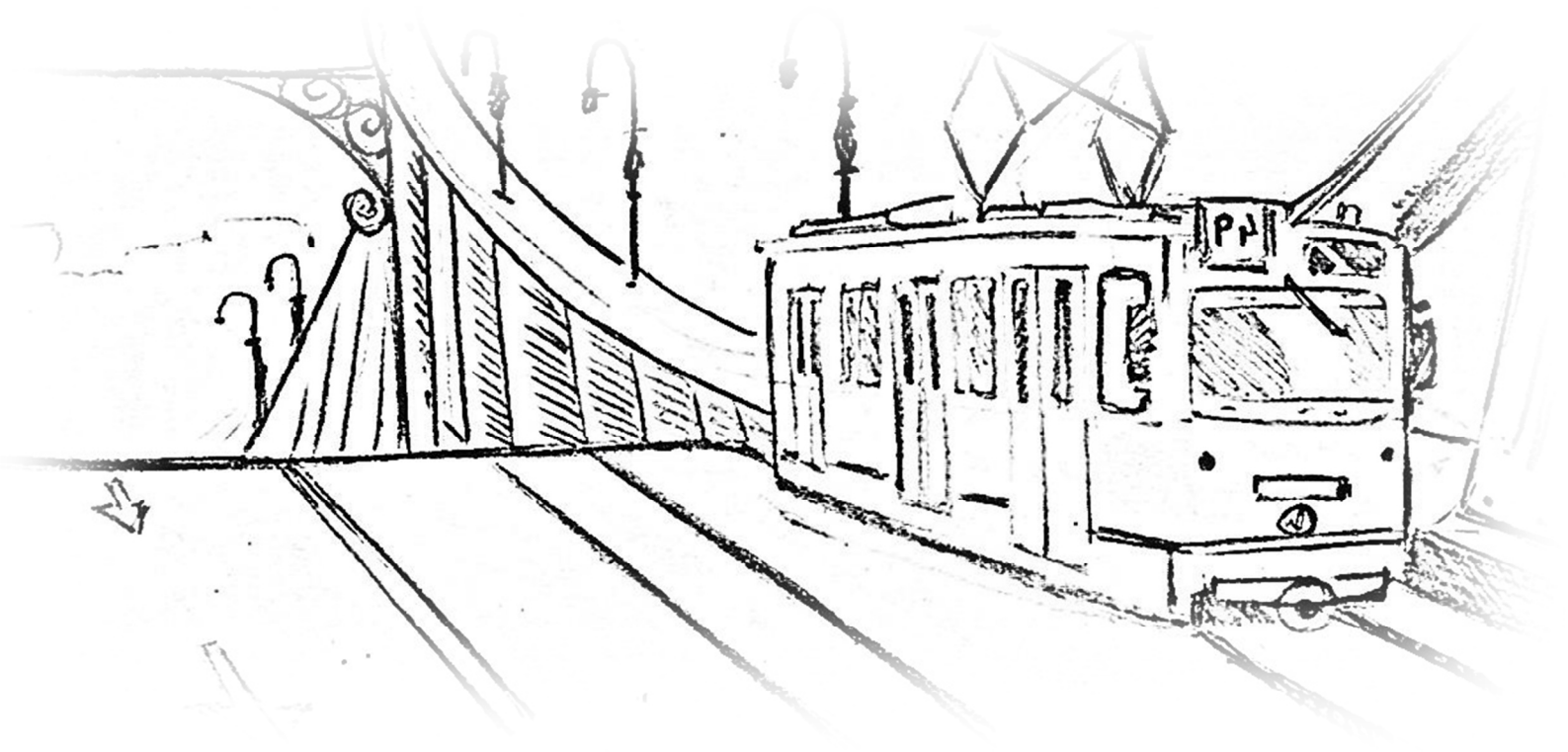

4.1 ROLE OF TRAM TRACKS

Tram lines were formed by two rails. The rails are arranged as the one of the key parts of the railway and act as support, guiding device element and conductor of electric current. The most important technical feature of the railway is the contact between the rail and wheel flange, being its main attributes its material, form and weight.

Definition of Rail:

The carbon rolled steel sections which are laid end to two parallel lines to provide a continuous and level surface for the trams to move and for carrying axle loads of it rolling stock, are called rails.

Functions of the Rails

The main functions of rails in a railway track are:

- Rails serve as path guide, forcing the tram to follow a specific route.
- Rails provide a continuous and levelled surface for the movement of the trains, getting the minimum friction between steel wheels and the rolling stock.
- Rails provide strength, durability and lateral guidance to the track.
- Rails bear the stresses developed due to heavy vertical loads, breaking forces and temperature changes.

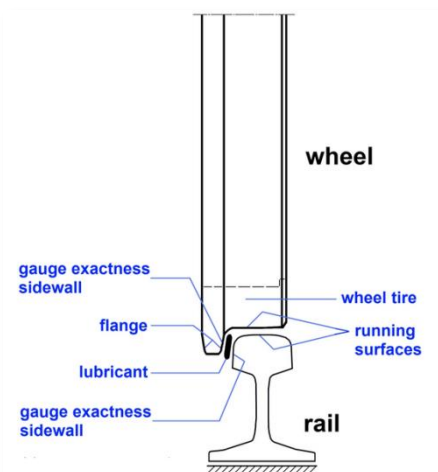

Source: www.arcelormittal.com

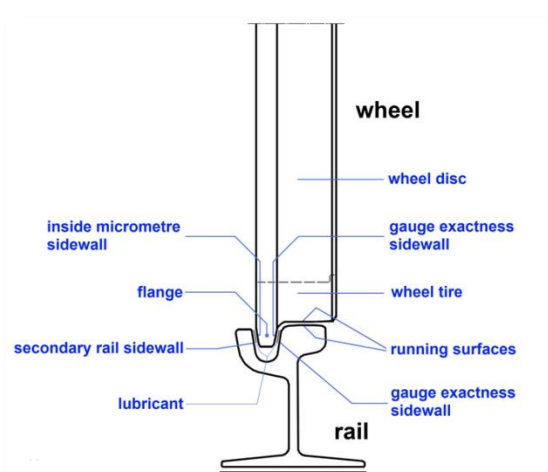

Source: www.arcelormittal.com

4.2 TYPE OF TRAM TRACKS

Almost from the beginning, one of distinguishing mark of the tramway transport is the ability to share the road surface (usually the public road) with other types of urban transport, such as road traffic (cars, buses, bicycles, etc.). This is possible because the guide rails are embedded in the road platform.

Vignole rail

The first type of rail used for trams was simple in form and it is known as the “Vignole” rail, after the English engineer who introduced in Europe the rail with a base invented by the American Stevens.

The symmetrical and balanced profile of this rail makes it very easy to roll. Has a wide base that allows it to be firmly fixed to the sleepers.

The principal characteristics of rails with regard to load transfer are their vertical inertia. This depends on the mass and height of the rail. In France, the different types of Vignole rail are characterized by their linear mass.

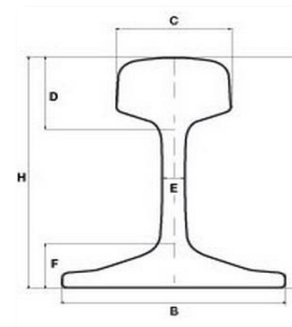

Vignole rail. Source:
www.arcelormittal.com

Grooved rail

Also called “Phoenix” rail, it is the rail type most popular around the world from tramways net.

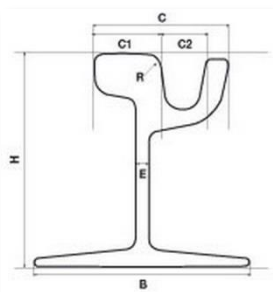

Grooved rail. Source:
www.arcelormittal.com

Grooved Rail was invented in 1852 by Alphonse Loubat as a special rail designed for tramways. This inventor also developed other improvements in trams and in rail equipment and he helped to develop the New York and Paris tramlines

The idea behind was to allow integration with other road users. This profile allows paving to both sides of the rails and to upper level, enabling the traffic to other road users.

Block rail

Block rail is a lower profile form of girder guard rail. The web of a girder guard rail is eliminated. In this profile it is like a solid form of bridge rail with a flange way and its guard added. Simply removing the web and combining the head section directly with the foot section would result in a weak rail, and so additional thickness is required in the combined section.

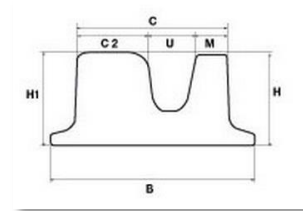

Block rail. Source:
www.arcelormittal.com

LR55 rail

Other type is the profile LR55. LR55 is a concept in tramway track and track laying which has been developed by Professor Lewis Lesley in Liverpool.

It comprises a string of concrete, lintel-like, blocks, laid along the line of each rail in a shallow trench cut in the road surface. The upper surface of the block is flush with the road surface and is cast with a groove. The rail, which is based on a rectangular grooved section, is retained flush with the surface of the block by a polyurethane mastic grout.

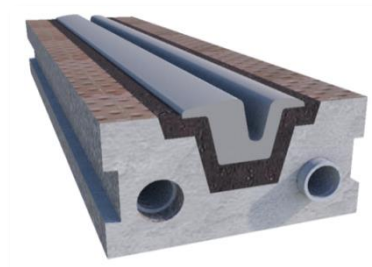

LR55 rail. Source:
www.railsystem.net

The mastic gives resilience to the rail, preventing rumbling noises being transmitted through the ground, and insulates it electrically, reducing leakage currents.

The broad base of the concrete spreads the load of the vehicle over a larger ground area than did the older rail sections. This reduces the amount of heavy foundation work needed beneath the track; and in many cases, the existing road foundation may be useable without alteration.

The ability of the pre-stressed lintel to span gaps makes it possible to keep the weight of tramway vehicles off a structure beneath. This means the expense of diversion of services is avoided and any weakness in the under-road cellars of Bath can be bridged.

4.3 ARCHITECTURE IN TRAM NET

As discussed in previous sections, the architecture is also present in a field of engineering, such as the tram net.

In Szczecin, this architecture is presented in the form of tram shelters, which has the function to mark the stops, as well as to protect passengers of weather actions. It is a metal structure. Such tram shelters are formed by a base, supports and a cover layer. Below, the characteristics, both material and constructive of these structures are shown.

1. Constructive characteristics:

First, the base or foundation of the structure is a layer of concrete which is chemically anchored to metal plates. Both plates are connected to lateral and back supports. The size of that plates varies depending on the section of the support received.

The anchors will be hidden under a layer, which will be seen, as it is shown in the picture.

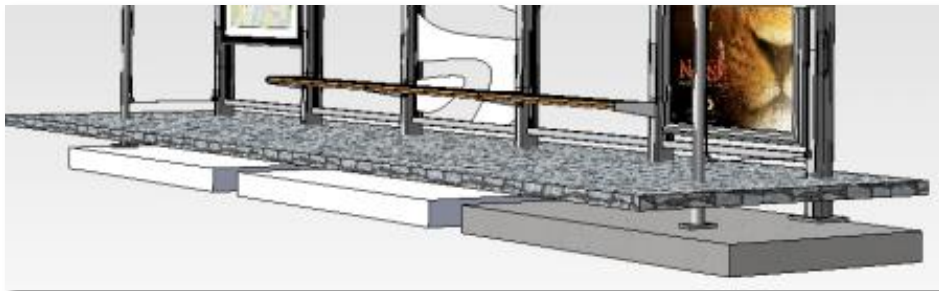

Source: Construction project of tram net in Szczecin

Concerning to the supports, there are two types, primary and secondary supports.

The main supports are L inverted-shaped. These pieces will ensure the stability of the structure, from its base to the cover. They are located at the back of the tram shelter. These are constituted of an aluminium system of dimensions 90 x 150 mm. This listing has a structure of two vaults, one of higher dimension, which serves to connect the base with the supports and another one with smaller dimension, whose function is to drain rainwater from the roof of the structure.

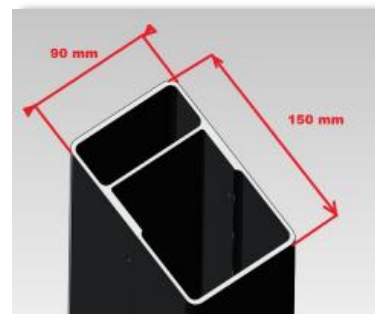

Source: Construction project of tram net in Szczecin

The structure is modular, so can be adapted to any length. The maximum length on-center of supports shall not exceed 1490 mm.

The secondary supports are located in the front of the structure, at the two ends. Their function is to provide stability to the structure and prevent the cover from losing its shape if the presence of rain or snow is high.

As the elements which are placed between supports, they are glass panels, both are placed in the cover, side or back surface.

The cover has an inclination toward the back of the structure. The water drainage shall be through the roof, and also the existing vault on the metal helps to.

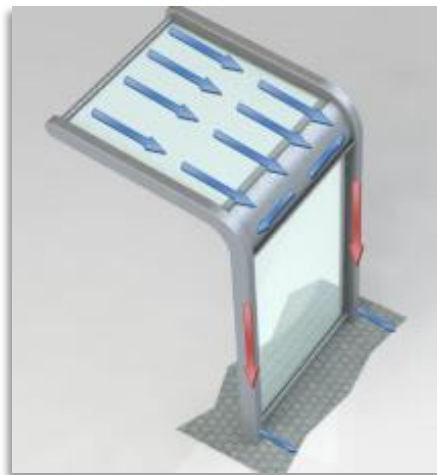

Source: Construction project of tram net in
Szczecin

The finish of the panels will be:

- a) The cover will be finished with paint, using RAL colours:
 - The first panel, from the right: green (RAL 6018)
 - The second panel from the right: light blue (RAL 5015)
 - The third panel: dark blue (RAL 5022)
 - The fourth and successive panel: white / matt

- b) In the lateral panels only a white line shall be placed at the height of 900 mm with a width of 80 mm. This option is intended to improve the visualization to passengers.
- c) Back panels, have several functions, so the type of finishing will depend on them:
- Information panel: it will inform about schedules, connecting lines, stops, etc., of the tram network. The panel will have the following dimensions:

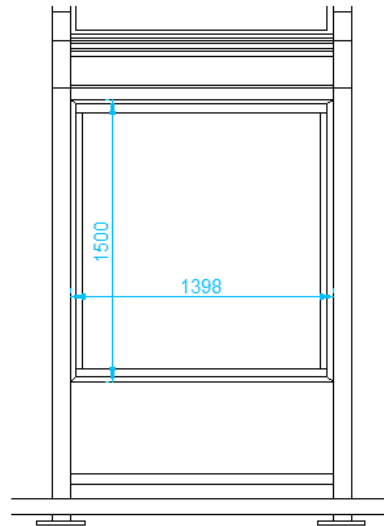

Information panel. Source: author

- Advertising panel: it will be show commercials.
- Decorative panels: the design that will occupy this space will be related to the promotion of the city in 2050 "Floating Garden". Furthermore, if there are more back panels, the white band would be placed, as in the side panels.

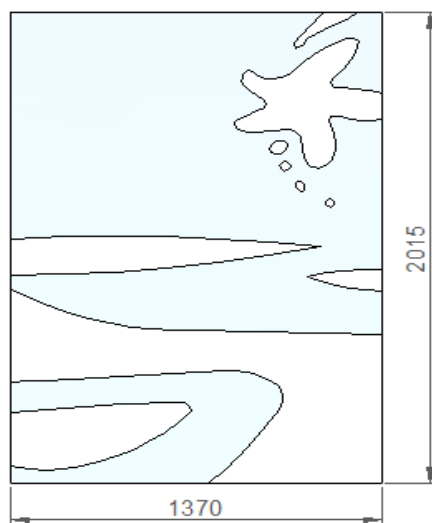

Decorative panel. Source: author

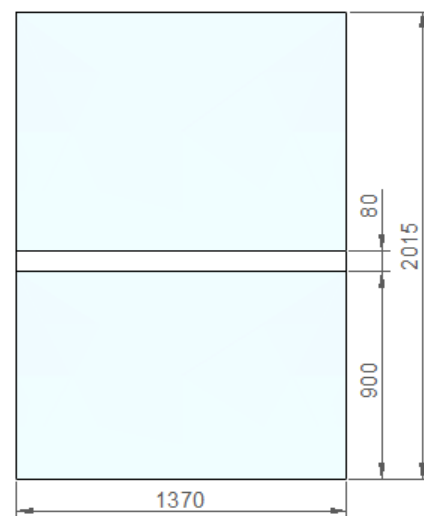

Decorative panel. Source: author

The structure will also include lighting, both in news and advertising panels. The illumination of these panels will be made with LEDs

2. Built materials

The structure is fully metal. The supports are aluminium, except the base plate and banks supports, which are made of steel.

The wall panels are tempered glass, with a security voilt of 8mm thick. For the cover, two layers of tempered glass 6 mm thick minimum each are used.

All screw connections (bolts, washers and nuts), is stainless steel A2 or A4.



Szwolzerow Station. Source: Author

Furthermore, in Valencia, as discussed above, the architecture in the area of the tram lines is not only in the form of shelters, but also in the form of small buildings.

Although there are tram shelters and stops to protect passengers from the weather actions, these sure are the majority. Therefore, the study will be also done of these metal structures in Valencia. As Szczecin, these tram shelters are formed by a base, supports and a cover layer.

1. Constructive characteristics:

As for the base, there is not a work of reconstruction or expansion in Valencia so we can't know for sure what kind of base is used for tram shelters in Valencia. Therefore, the same solution is proposed that in Szczecin.

As for the supports, they have a circular section and are only arranged on the back part of the structure. There are also two side supports, but these are not directly connected to the structure, since they belong to a secondary structure located to the side for supporting the advertising panels.



Carrasca tram stop. Source: author

The main supports, which ensure the stability structure from its base to the cover, have a circular cross section. Located at the back of the tram shelter, they consist of metal sections which have a frusta-conical shape. In the highest part of the support is welded a metal plate, which provide an interface between the post and the supporting structure of the roof elements.

The structure is modular, so it can also be adapted to any length. Although the maximum length between the axes of the supports is greater than in Szczecin since the system is different. This distance is not greater than 3 m.



Carrasca tram stop.
Source: author

The side supports are placed on both sides of the tram shelter. Its function is to support the advertising panels. The section of these supports is rectangular. These are not attached directly to the basic structure; they are only a support for the panels.

To endure the elements which are between supports there is a horizontal metal structure. They are rectangular and are attached to the supports by bolts and metal plates



Carrasca tram stop. Source: author

As for the cover, it is formed by a transverse structure, which has main elements and secondary elements. The first are anchored to the supports and they have the function of supporting the loads transmitted by the cover. Secondary elements are arranged between the main elements, whose function is to support the cover elements.

There are also cross-members, which help the cover stability and provide greater resistance to the cover elements.

The cover is arch-shaped, with an inclination toward the back of the structure in order to evacuate the water.



Carrasca tram stop.
Source: author

As for the cover members there are back panels, finishing elements of the cover and the side information panels:

- a) The back panels are made of glass. They are located between the supports in three modules, each of them is 1 m wide and is located 0.4 m from the floor. These panels are informative elements, such as the name of the stop, the tram direction, etc. Then its dimensions are shown:

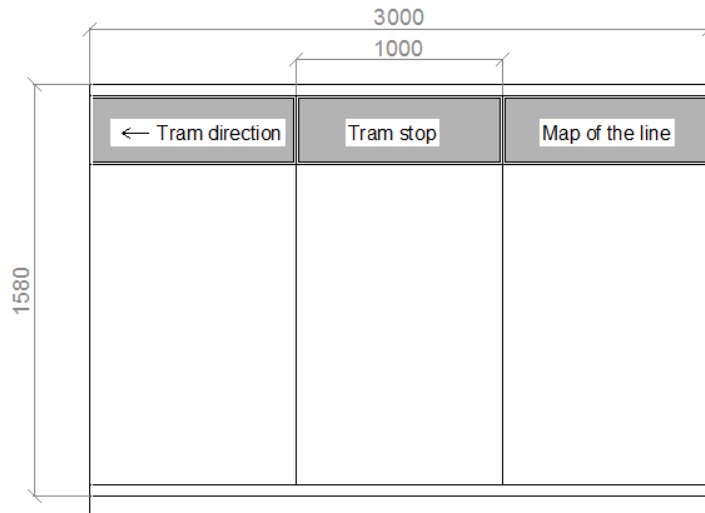

Back panels. Source: author

- b) The elements of the cover are made of a durable plastic. Their function is to protect passengers from the weather actions.
- c) Advertising panels: they are the side cover elements. These elements as mentioned above are supported on a secondary support. Are intended to advertising and its dimensions are as follows:

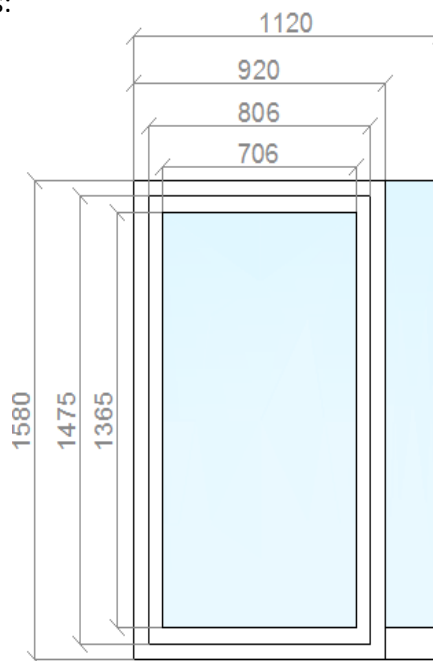

Advertising panels. Source: Author

Instead in Szczecin, in Valencia tram tickets can be bought at the same stop, for it, there are in the center (or in the side) of the tram shelter a machine whose function is dispense and validate tickets. Here we can also find some information panels that inform us about all lines, both tram and metro.



Carrasca tram stop. Source: author

Finally, the stops have wooden seats, which are subject to horizontal structure by metallic profiles.



Carrasca tram stop. Source: author

CHAPTER 5:
STUDY AND
CONSTRUCTIVE AND
EQUIPMENT ANALYSIS

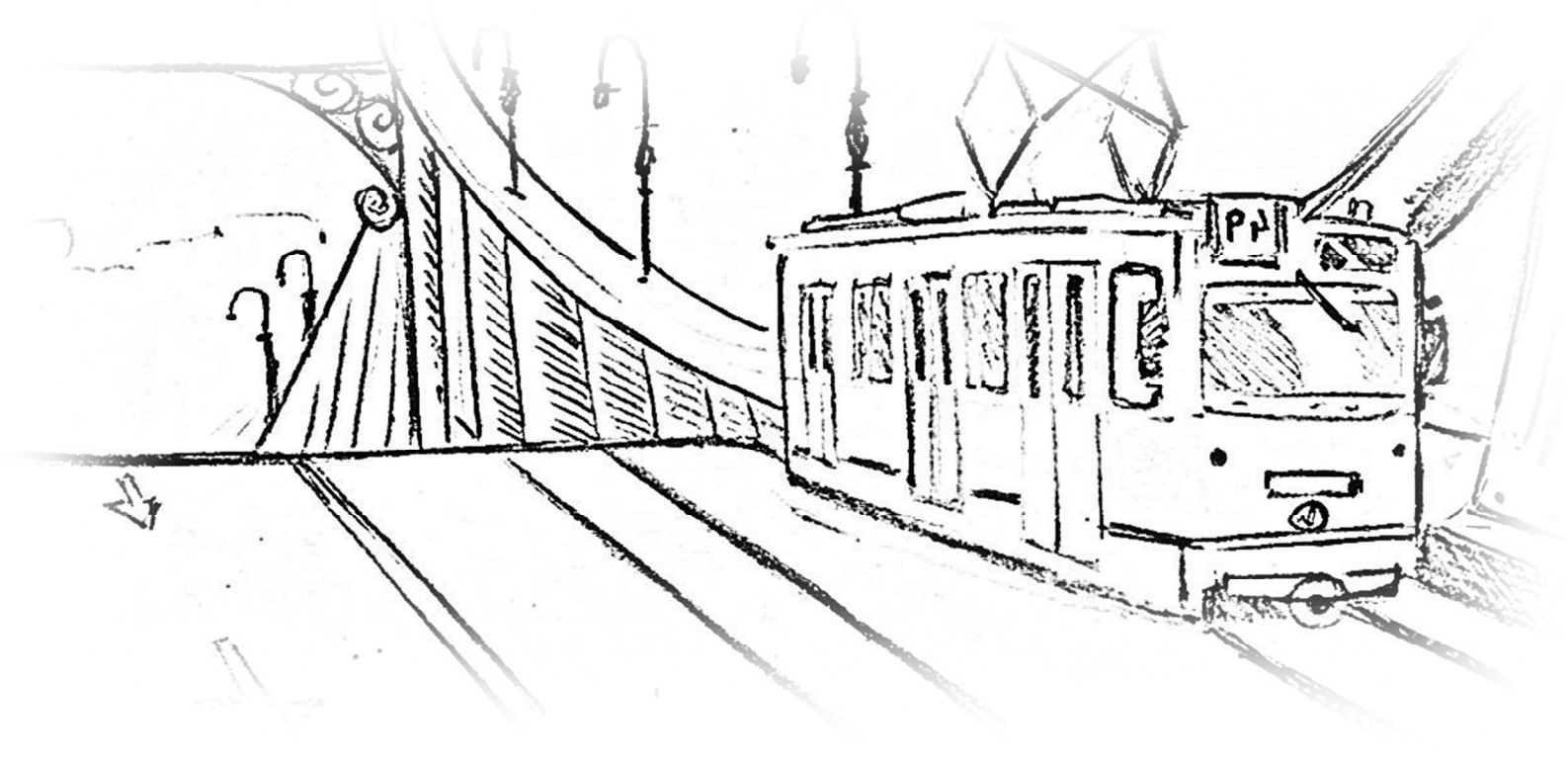

5.1 CONSTRUCTION DETAILS

Here are the construction details pertaining to the tram construction works in Szczecin, both on Piastow Avenue and Potulicka Street.

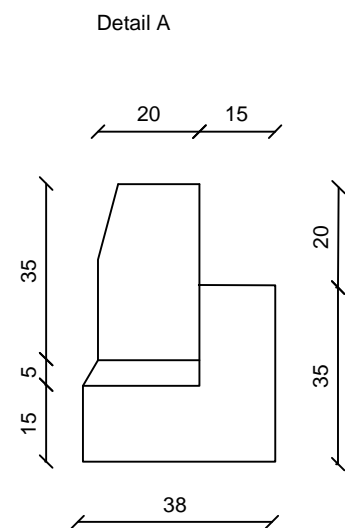
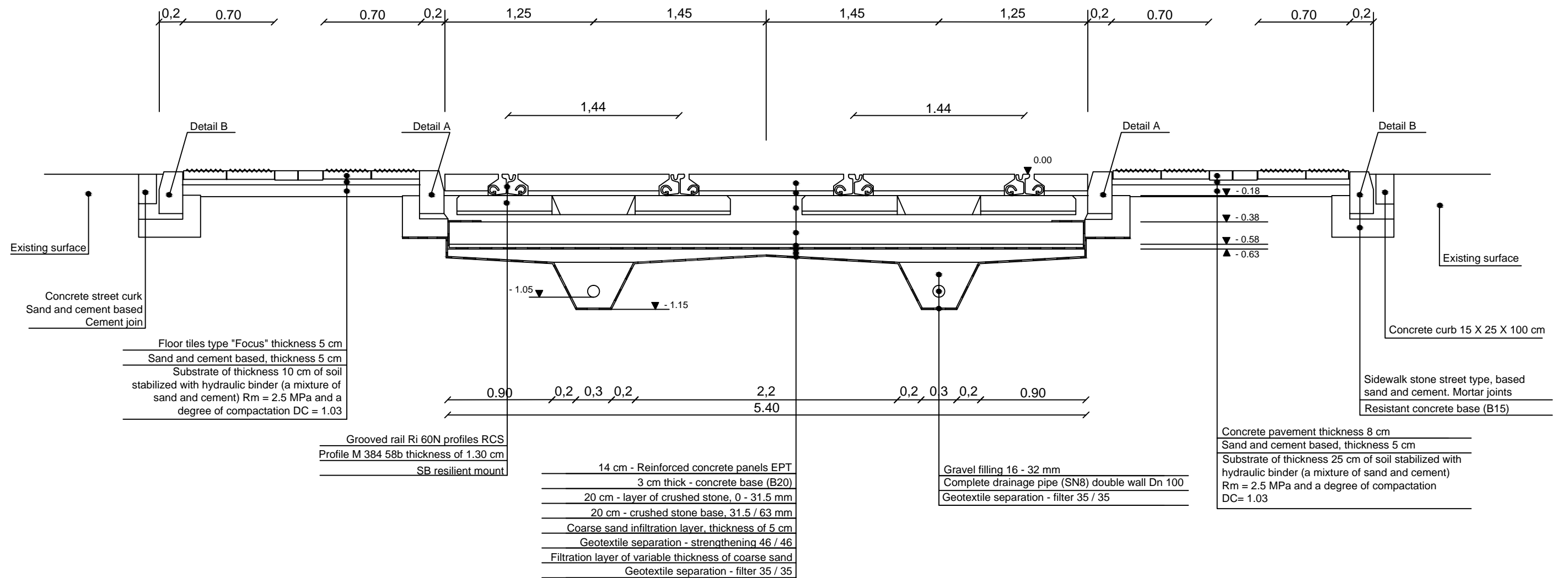

Scale: $\frac{1}{15}$

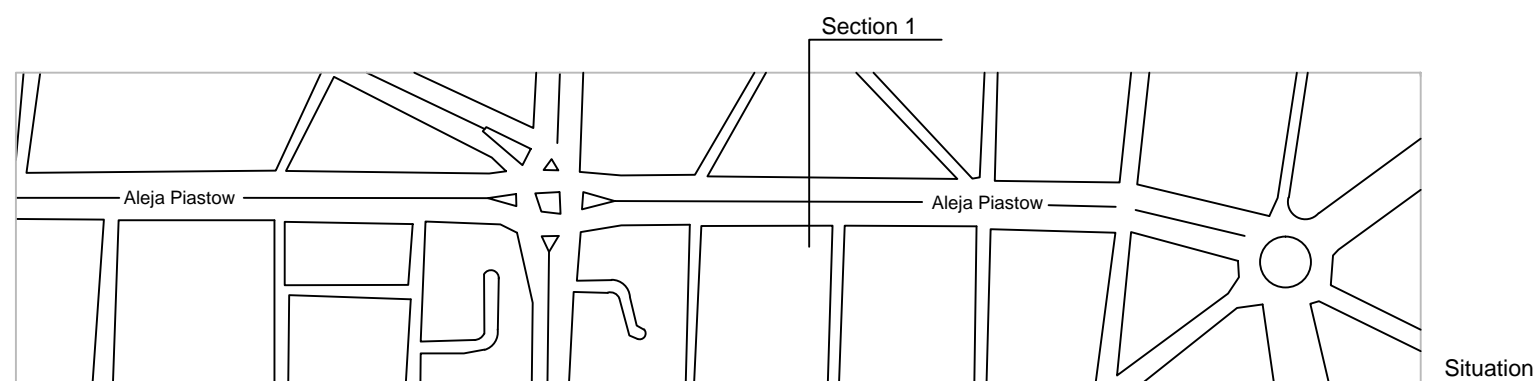
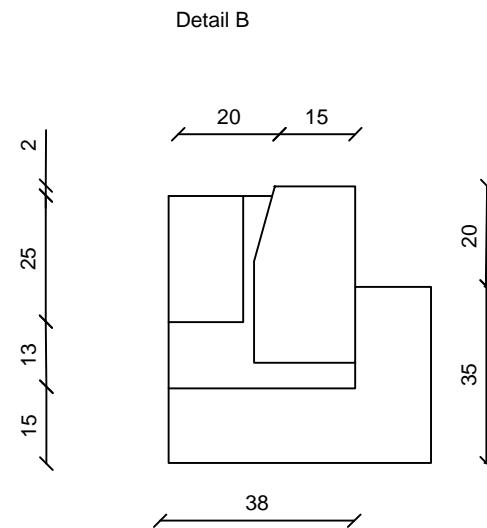

Final Project: comparative study between Szczecin and Valencia of the construction of the tramway infrastructure		
Title of plane: Detail of Piastow street; Section 1		
Authors: PÉREZ TOMÁS, Tania TAMARIT LATRE, Irene	Course: 2013 - 2014	
Scale: $\frac{1}{35}$	Situation: Szczecin	Nº of plane: 9

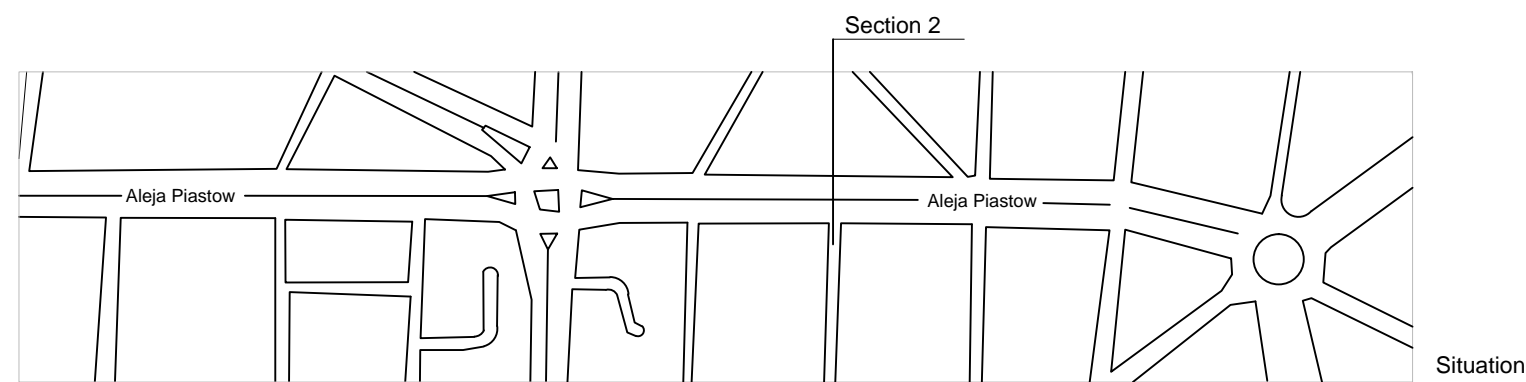
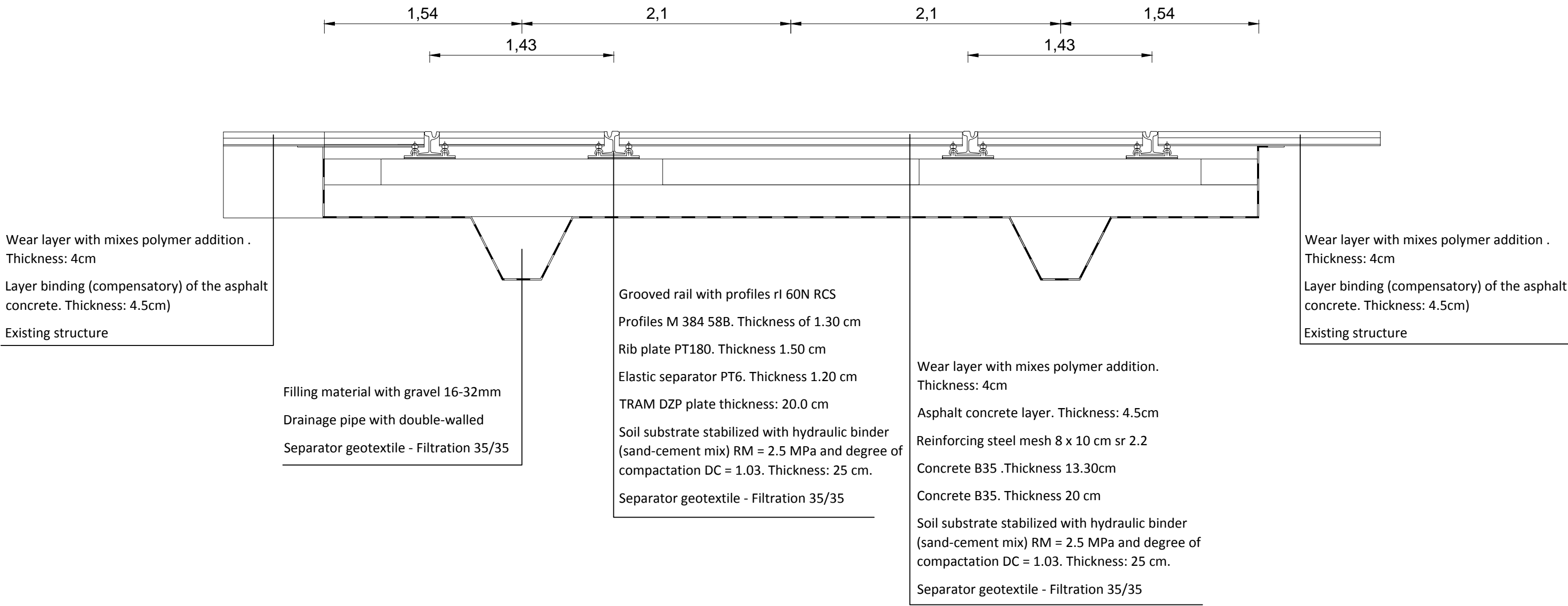

Final Project: comparative study between Szczecin and Valencia of the construction of the tramway infrastructure		
Title of plane: Detail of Piastow street; Section 2		
Authors: PÉREZ TOMÀS, Tania TAMARIT LATRE, Irene	Course: 2013 - 2014	
Scale: $\frac{1}{30}$	Situation: Szczecin	Nº of plane: 10

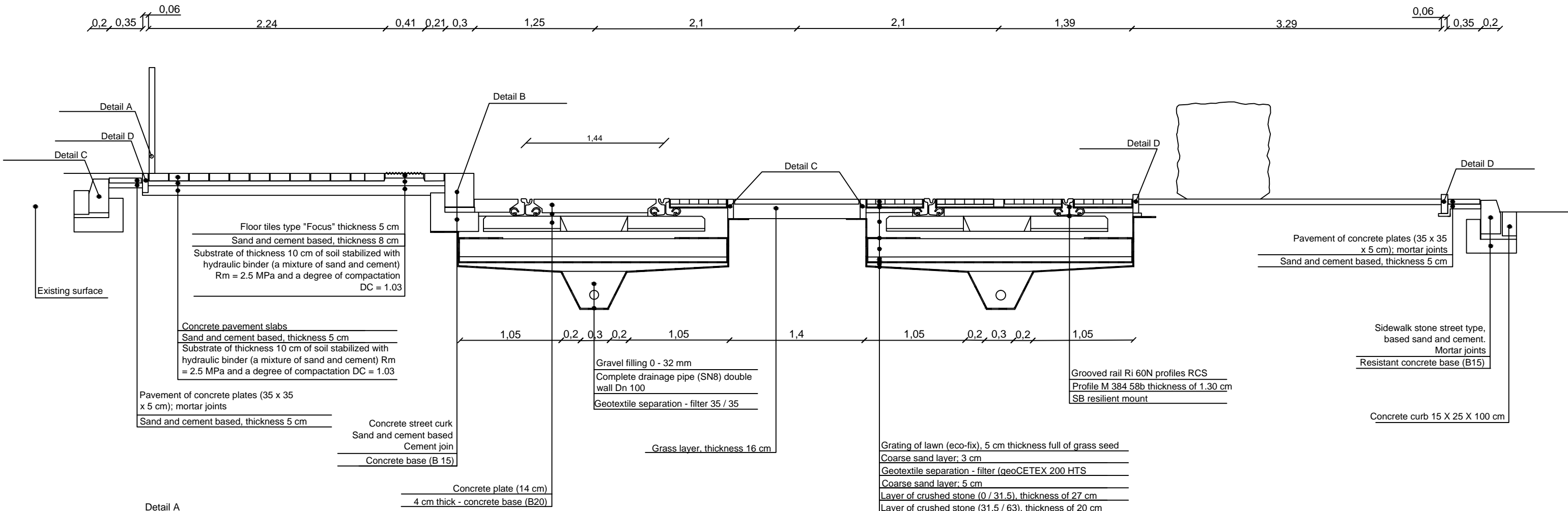

Detail A

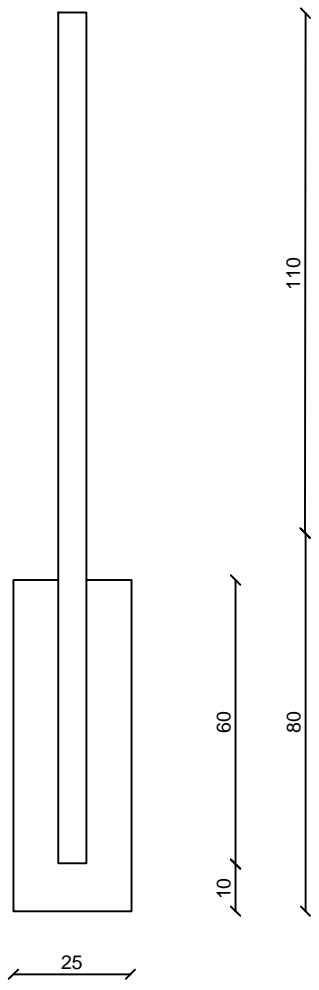

Detail B

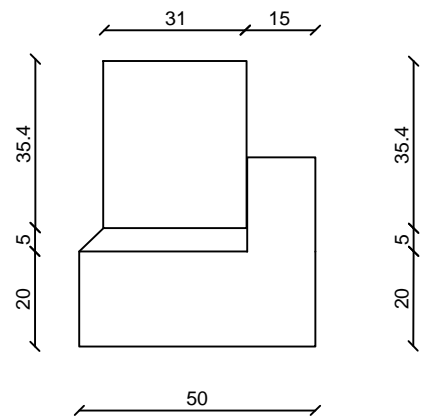

Detail C

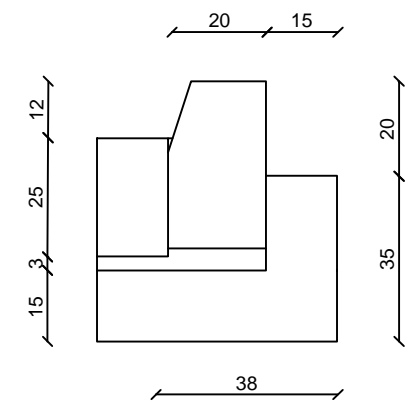

Detail D

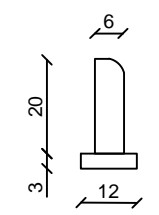

Scale: $\frac{1}{16}$

Section 3

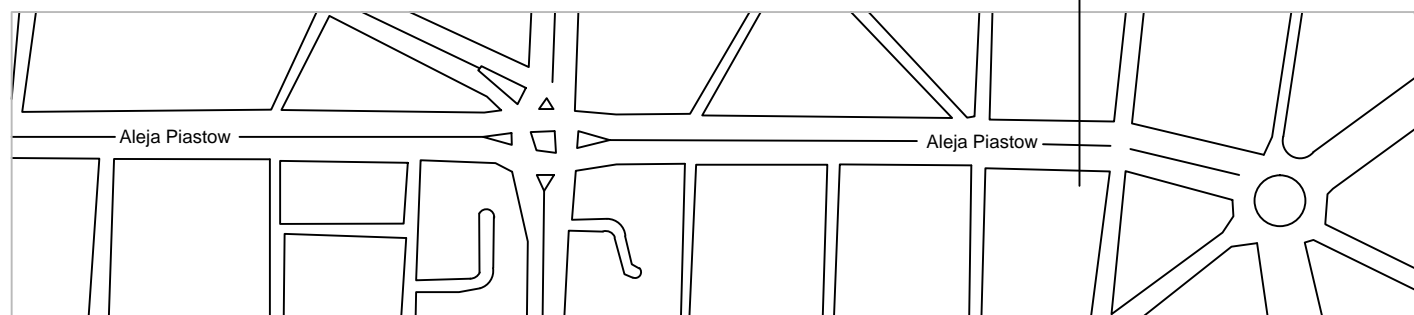

Final Project: comparative study between Szczecin and Valencia of the construction of the tramway infrastructure		
Title of plane: Detail of Piastow street; Section 3		
Authors: PÉREZ TOMÀS, Tania TAMARIT LATRE, Irene	Course: 2013 - 2014	
Scale: $\frac{1}{30}$	Situation: Szczecin	Nº of plane: 11

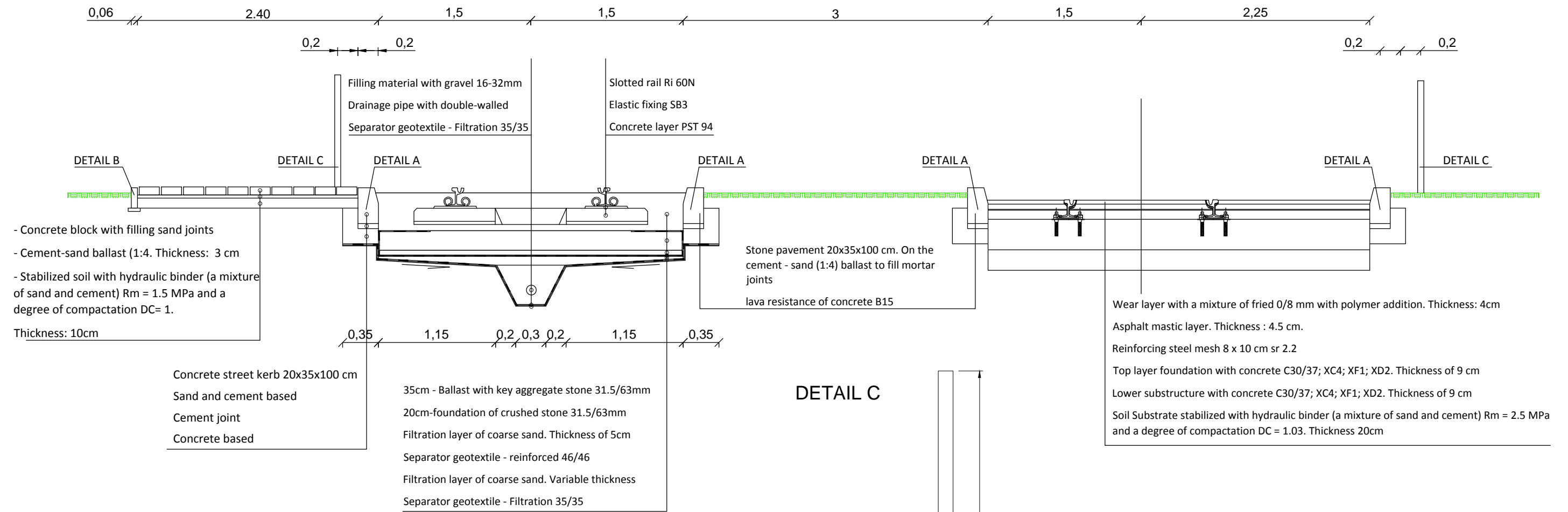

DETAIL C

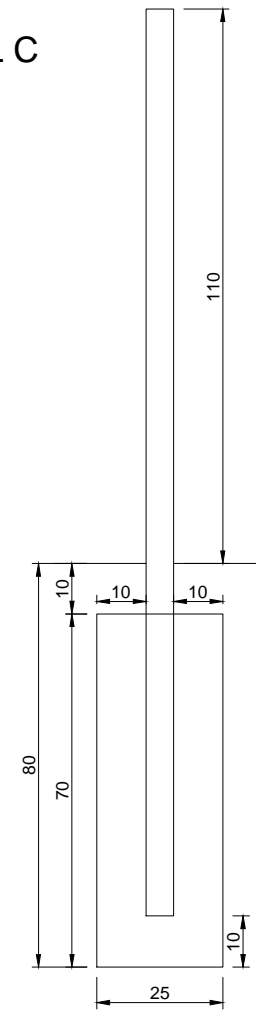

Scale: 1/15

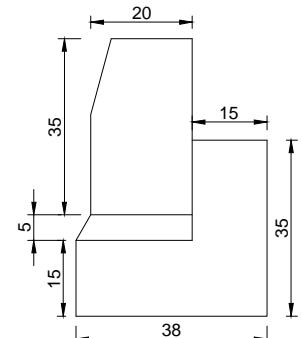

DETAIL A

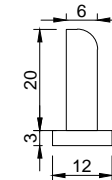

DETAIL B

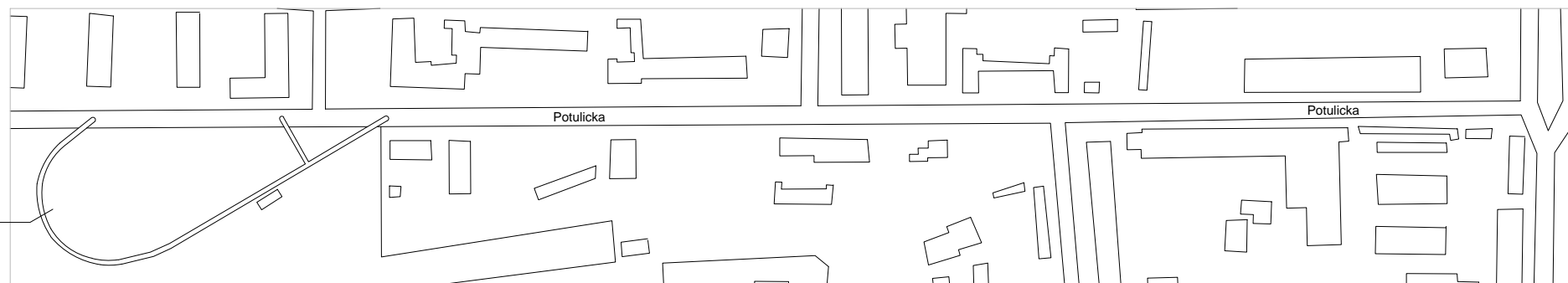

SITUATION

Final Project: comparative study between Szczecin and Valencia of the construction of the tramway infrastructure		
Title of plane: Detail of Potulicka street; Section 1		
Authors: PÉREZ TOMÀS, Tania TAMARIT LATRE, Irene	Course: 2013 - 2014	
Scale: $\frac{1}{40}$	Situation: Szczecin	Nº of plane: 12

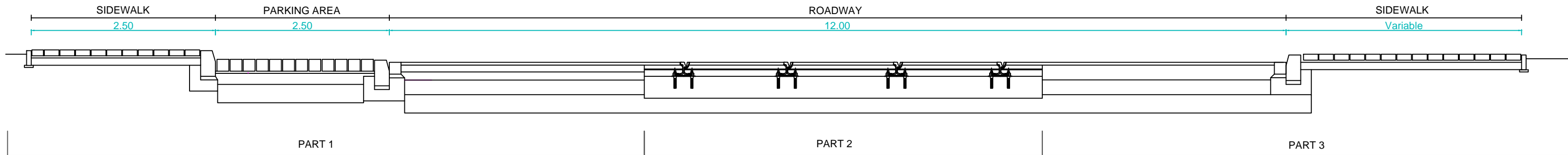

Situation

Final Project: comparative study between Szczecin and Valencia for the construction of the tramway infrastructure		
Title of plane: Section 2 of Potulicka street		
Authors: PÉREZ TOMÀS, Tania TAMARIT LATRE, Irene		Course: 2013 - 2014
Scale: $\frac{1}{50}$	Situation: Szczecin	Nº of plane: 13

PART 1

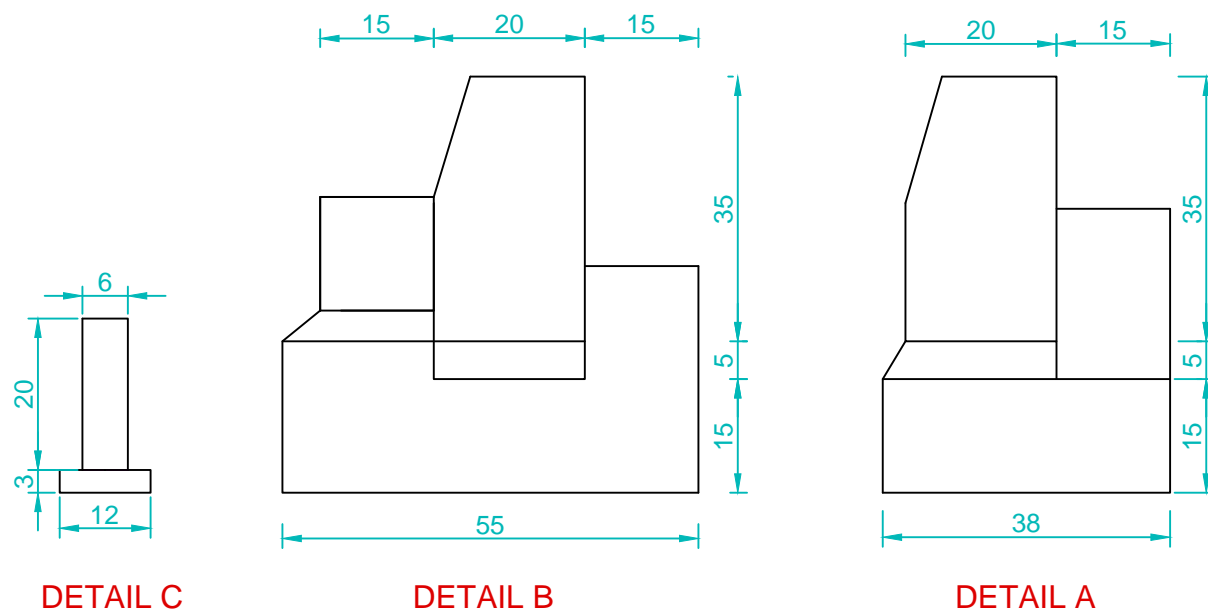
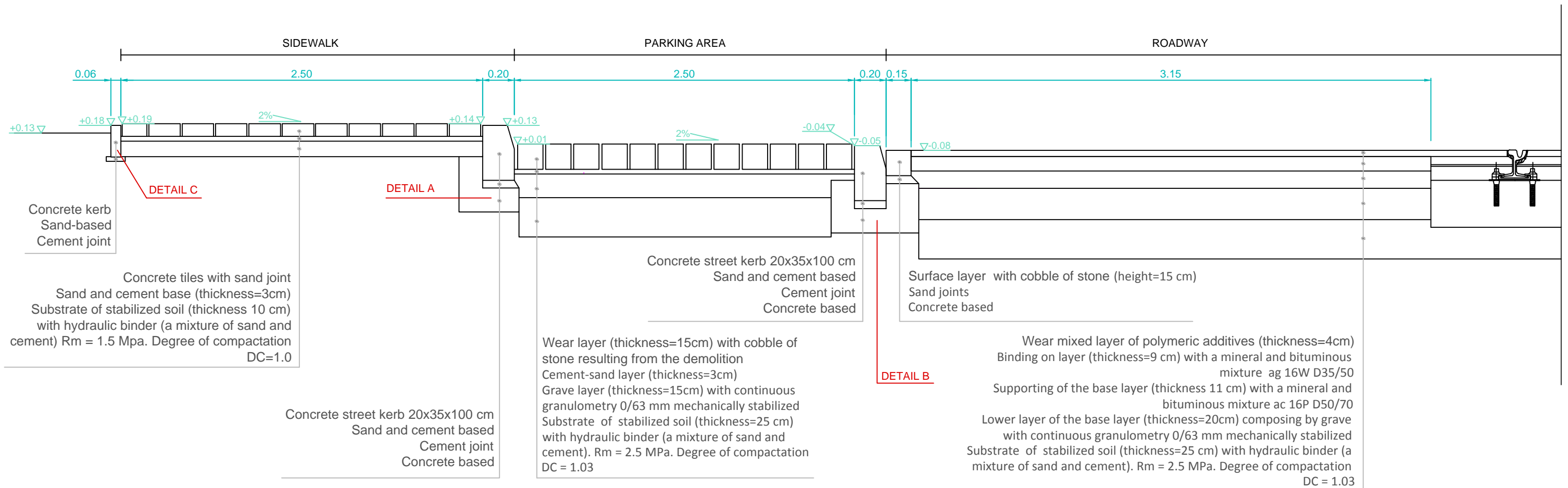

Scale: 1/10

Final Project: comparative study between Szczecin and Valencia for the construction of the tramway infrastructure		
Title of plane: Detail of Potulicka street section 2; Part 1		
Authors: PÉREZ TOMÀS, Tania TAMARIT LATRE, Irene	Course: 2013 - 2014	
Scale: $\frac{1}{25}$	Situation: Szczecin	Nº of plane: 14

PART 2

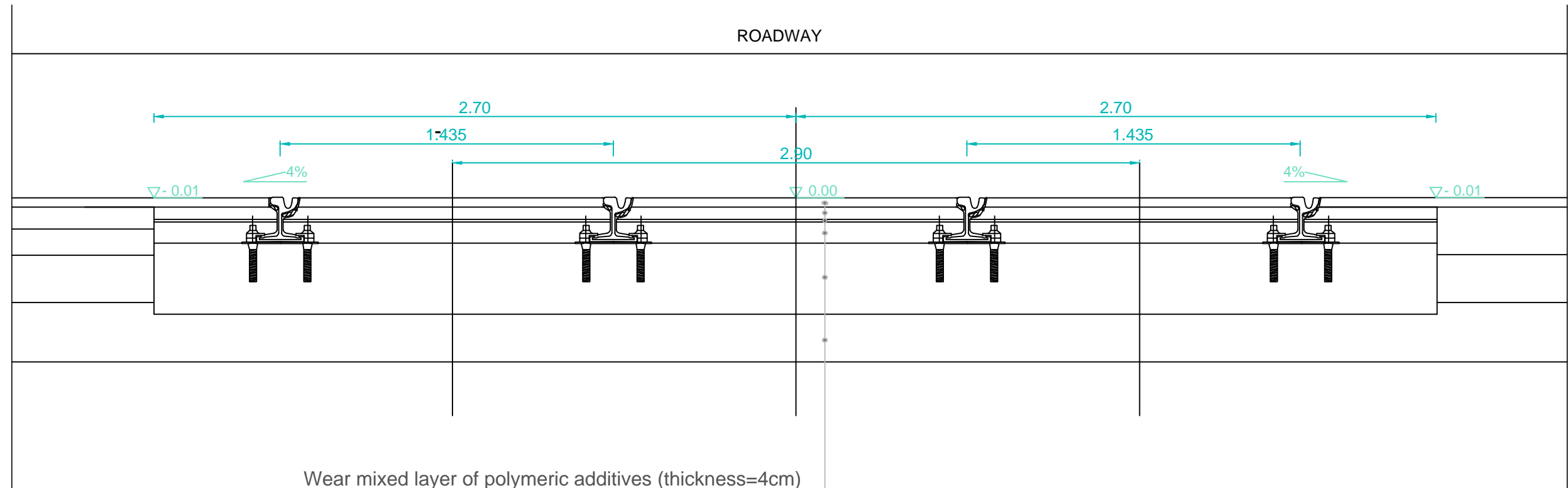

Wear mixed layer of polymeric additives (thickness=4cm)
 Layer of mastic asphalt (thickness=4.5cm)
 Wire reinforcement mesh 8 x 10 cm
 Top layer of the substructure composing by concrete C30/37;; XC4;
 XF1;XD2 (thickness=9cm)
 Lower layer of the substructure composing by concrete
 C25/30;XC2 (thickness=30cm)
 Substrate of stabilized soil (thickness=25 cm) with hydraulic binder (a
 mixture of sand and cement). $R_m = 2.5$ MPa. Degree of compactation
 DC= 1.03

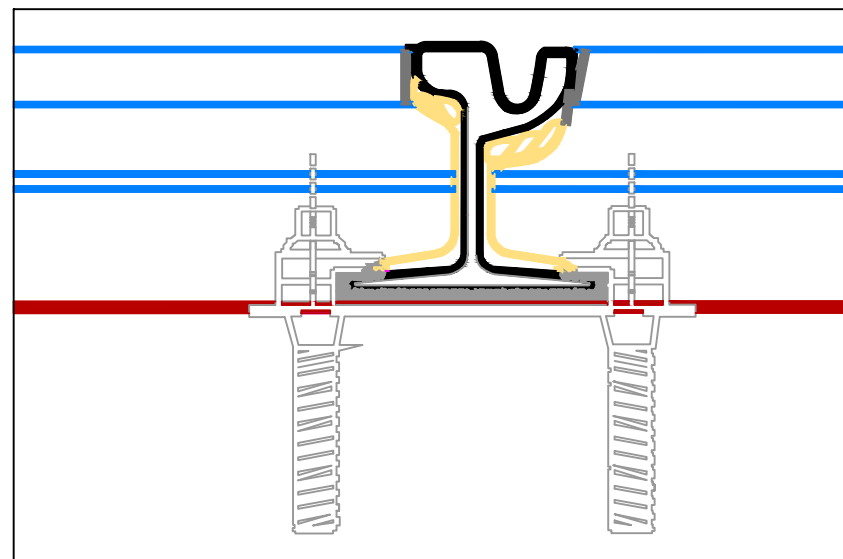

Scale: 1/20

Final Project: comparative study between Szczecin and Valencia for the construction of the tramway infrastructure		
Title of plane: Detail of Potulicka street section 2; Part 2		
Authors: PÉREZ TOMÀS, Tania TAMARIT LATRE, Irene	Course: 2013 - 2014	
Scale: $\frac{1}{20}$	Situation: Szczecin	Nº of plane: 15

PART 3

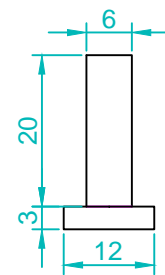
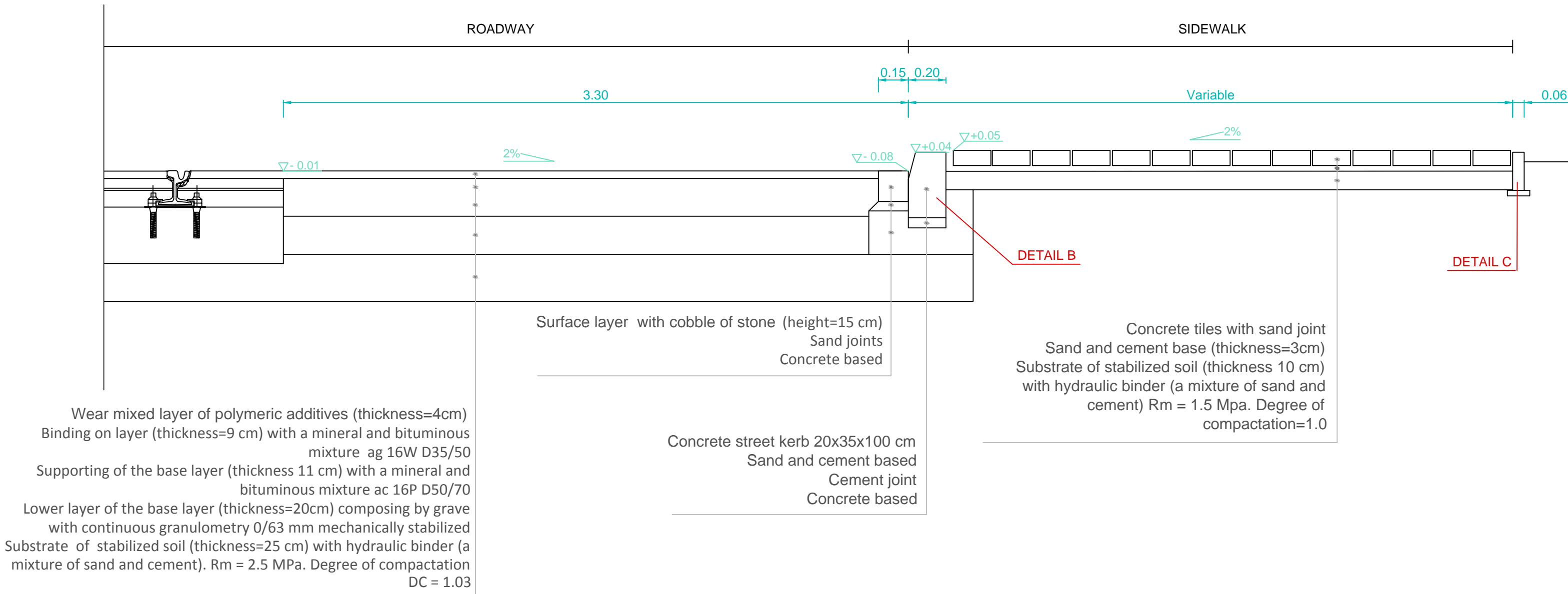

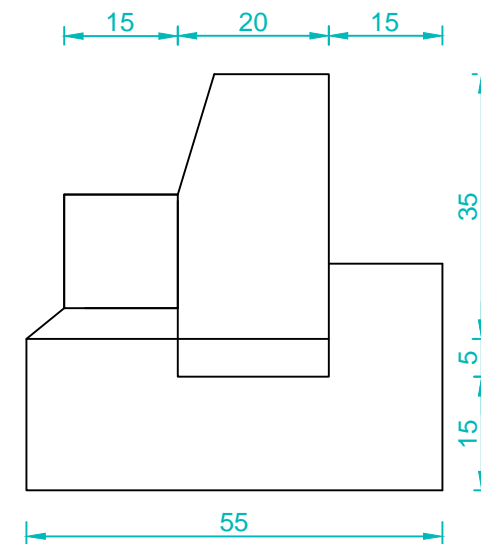

Scale: 1/10 **DETAIL C**



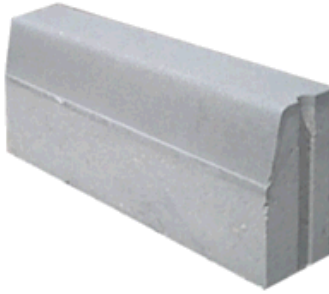

DETAIL B

Final Project: comparative study between Szczecin and Valencia for the construction of the tramway infrastructure		
Title of plane: Detail of Potulicka street section 2; Part 3		
Authors: PÉREZ TOMÀS, Tania TAMARIT LATRE, Irene	Course: 2013 - 2014	
Scale: $\frac{1}{20}$	Situation: Szczecin	Nº of plane: 16

5.2 TYPE OF MATERIALS AND SUITABILITY

TECHNICAL DATA MATERIAL	
Name:	Concrete Curb
Definition:	<p>It is a precast concrete element designed to separate surfaces of the same or different level to providing:</p> <p>Separation of surfaces subjected to different traffic types</p> <p>Drainage networks individually or in combination with other curbs</p> <p>Physical or visual delineation</p>
	
Composition:	<p>the concrete curbs are composed of cement, aggregates, water, additives and pigments (only in the finish coat).</p>
Dimension:	6 x 20 x 75 cm
Technical specification:	<p>Water absorption: the average value of water absorption coefficient $C_a=9\%$ of the mass.</p> <p>Flexural resistance</p> <p>Resistance to brasion: in order to ensure the durability of the element for routine use for which it is marketed.</p> <p>Slip resistance: in normal conditions of use, concrete curbs should have slip resistance throughout its lifetime.</p>
Use and maintenance:	<p>Precast concrete curbs require low maintenance because to fulfill the conditions of testing abrasion wear, flexural strength and water absorption, guarantee a long service life.</p> <p>Cleaning is recommended every 5 years.</p>
Sustainability level:	<p>Thanks to its durability and long period of use, prefabricated concrete elements are particularly sustainable products.</p> <p>The concrete curbs can be reused if they are in a good condition.</p>
Marking:	



TECHNICAL DATA MATERIAL		
Name:	Concrete Curb	
Definition:	<p>It is a precast concrete element designed to separate surfaces of the same or different level to providing:</p> <ul style="list-style-type: none"> Separation of surfaces subjected to different traffic types Drainage networks individually or in combination with other curbs Physical or visual delineation 	
Composition:	<p>the concrete curbs are composed of cement, aggregates, water, additives and pigments (only in the finish coat).</p>	Dimension: 20 x 35 x 100 cm
Technical specification:	<p>Water absorption: the average value of water absorption coefficient $C_a=9\%$ of the mass.</p> <p>Flexural resistance</p> <p>Resistance to brasion: in order to ensure the durability of the element for routine use for which it is marketed.</p> <p>Slip resistance: in normal conditions of use, concrete curbs should have slip resistance throughout its lifetime.</p>	
Use and maintenance:	<p>Precast concrete curbs require low maintenance because to fulfill the conditions of testing abrasion wear, flexural strength and water absorption, guarantee a long service life.</p> <p>Cleaning is recommended every 5 years.</p>	
Sustainability level:	<p>Thanks to its durability and long period of use, prefabricated concrete elements are particularly sustainable products.</p> <p>The concrete curbs can be reused if they are in a good condition.</p>	Marking: 



TECHNICAL DATA MATERIAL	
Name: Geotextile separation	
<p>Definition: Plane, permeable, polymeric textile material, which is used in contact with soil and other materials. In this case their main function is to separate two layers.</p>	
<p>Composition: Usually of synthetic origin due to their durability. The main are polyamides, polyesters and polyolefins (polyethylene and polypropylene)</p>	<p>Dimension: Dimensions vary from one company to another. These are usually given in rolls</p>
<p>Technical specification: Traction resistance Resistance to perforation Dynamic perforation for free-fall cone Effective pore opening Appropriate geotextile thickness</p>	<p>Functions:</p> <div style="display: flex; flex-wrap: wrap; justify-content: space-around;"> <div style="text-align: center;"> <p>Separation</p> </div> <div style="text-align: center;"> <p>Protection</p> </div> <div style="text-align: center;"> <p>Filtration</p> </div> <div style="text-align: center;"> <p>Reinforce</p> </div> </div>
<p>Sustainability level: Sustainability of geotextiles depends on the material base that they are formed, ie:</p> <ol style="list-style-type: none"> 1. Polyamides or polyesters: since it is materials derived from petrolio, the sustainability of such material will not be very high. Even if it is recycled, the environmental impact is less sinse 70% less oil is used. 2. Polyolefins:they are plastic so their biodegradation is very slow. Although the production process are more sustainable than the above materials. 	
<p>Use and maintenance: This material has very complicated maintenance since it is located in a lower layer.</p>	<p>Marking:</p>



TECHNICAL DATA MATERIAL	
Name:	Aluminum railing protection
Definition:	Parapet composed of a series of aluminum balusters harnessed to protect or support.
Composition:	Aluminum
Dimension:	height = 110 cm
Technical specification:	<p>The following tests should be performed:</p> <ol style="list-style-type: none"> 1. Ultimate limit state: verifies that the railing and the post should be designed to withstand 0,30 kN applied perpendicular to the plane on the unfavorable points of the system. 2. Serviceability limit state: the arrow mustn't be more than 55 mm when a horizontal load of 0,3 kN is applied, at the most unfavorable point. 3. Accidental load: handrails shall withstand a gravitational point of 1,25 kN.
Use and maintenance:	<p>Each year a visual inspection shall be performed to verify that the anchors as well as all elements are in a good conditions. If they are, the problem will be solved.</p> <p>Every three years, replacement of the surface paint (if it is applicable).</p>
Sustainability level:	<p>Aluminum can be considered sustainable because:</p> <ol style="list-style-type: none"> 1. It has a long shelf life. 2. Easy maintenance. 3. High level of reuse or recycling.
Marking:	



TECHNICAL DATA MATERIAL	
Name:	Concrete pavement
Definition:	<p>Surface layer of precast concrete for covering the soil to make it resistant, smooth and flat.</p> <p>Being an outdoor surface must be able to support climate changes.</p>
Composition:	<p>the concrete curbs are composed of cement, aggregates, water, additives and pigments (only in the finish coat).</p>
Dimension:	20 x 20 cm
Technical specification:	<p>Water absorption: the average value of water absorption coefficient $C_a=9\%$ of the mass.</p> <p>Flexural resistance</p> <p>Resistance to abrasion: in order to ensure the durability of the element for routine use for which it is marketed.</p> <p>Slip resistance: in normal conditions of use, concrete curbs should have slip resistance throughout its lifetime.</p> <p>Impact resistant</p>
Use and maintenance:	<p>Maintenance of concrete pavement is poor because of its durability. Although it would be convenient to make the following revisions:</p> <ul style="list-style-type: none"> · Every two years make a cursory review (presence of moisture, cracks, fissures, etc) · Every five years, review and repair joints and change the broken or defective parts.
Sustainability level:	<p>Given its long life, the environmental impact of concrete pavements is favorable. Plus, it doesn't need much maintenance and repair. Other hand, saving raw materials, transportation and energy is evident</p>
Marking:	CE



TECHNICAL DATA MATERIAL	
Name: Rail Ri60N	
Definition: Guide or rail through which the tram runs or slides.	
Composition: the rails are formed by high - strength steel.	Dimension: 18 x 18 x 180 cm
<p>Technical specification: The rail head must have a sufficient width and height to the loads. The rolling contact should not be punctual, handing the efforts to prevent wear. The thickness of the center of the track have to transmit the solicitations from the head to the base, taking into account corrosion and lateral forces.</p> <p>The relation of thickness / width of the center must be less than 0,075, and the outer thickness greater then 11 mm in order to avoid irregular cooling in case of welding.</p>	
<p>Use and maintenance: Leveling and alignment of the road. Geometric replacement work of the rail parameters. Chemical treatments through the application of plant protection products. Grinding and stabilized. Recess operations and defect correction of the rails mechanically. Greased rails devices (turnouts, crossing,...)</p>	
Sustainability level: Rails have a very long life. Therefore, transportation, production of rails is not high. But keep en mind that steel production much CO2 is emitted to the atmosphere.	Marking:

5.3 MATERIAL – TEMPERATURE – RESISTANCE RELATIONSHIP

Temperature is an external factor of great importance because it affects the majority characteristics of the materials. The mechanical, electrical or magnetic properties experience significant changes when the temperature varies.

When building it must be taken into account these effects that temperature can have on the materials, especially when they are exposed to the weathering 24 hours a day as is the case of the tram tracks.

For this reason it is interesting to analyse the minimum, medium and maximum temperatures of Valencia and Szczecin.

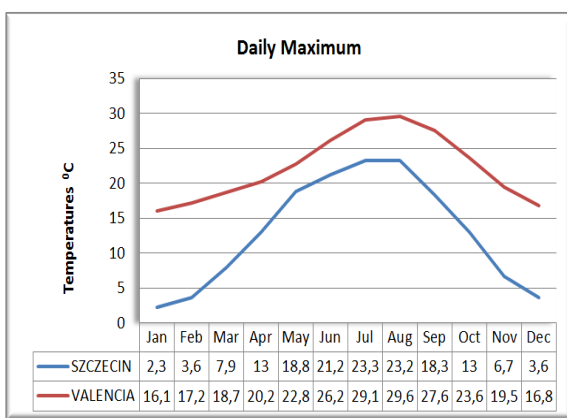

Graphic 1: Comparative of maximum temperatures.
Source: Author

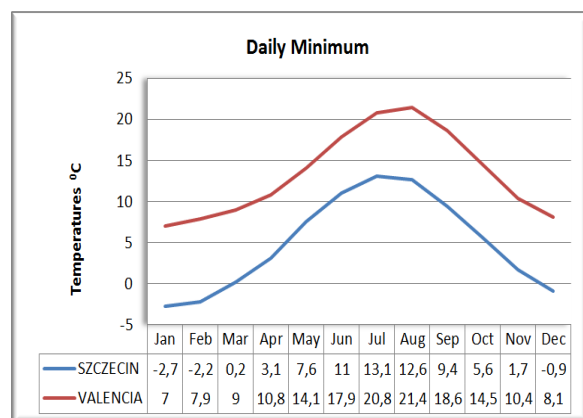

Graphic 2: Comparative of minimum temperatures.
Source: Author

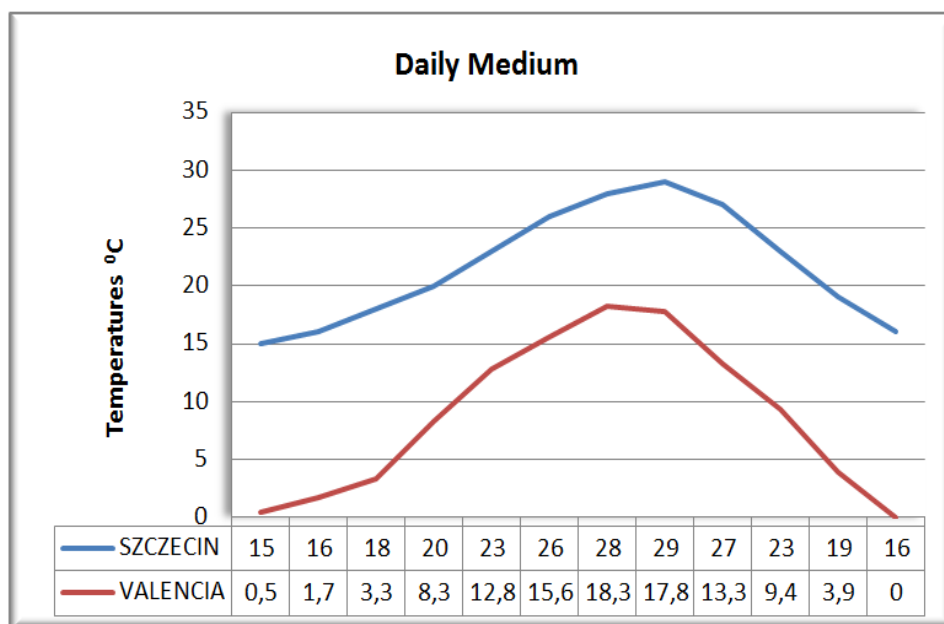

Graphic 3: Comparative of medium temperatures.
Source: Author

As we can observe in the graphics the climate of Szczecin is very different, depending on the season in which you are. Temperatures range from a low of $-3\text{ }^{\circ}\text{C}$ in February to a high of $23\text{ }^{\circ}\text{C}$ in July and August. The same thing happens in Valencia although the temperatures are always higher, ranging from $7\text{ }^{\circ}\text{C}$ to nearly $30\text{ }^{\circ}\text{C}$ in summer.

These thermal cycles produce that materials undergo an increase in volume due to capillary absorption. When the water evaporates, materials are dried and shrinkage occurs exceeding the expansion by increasing moisture. This causes stresses on the material causing erosion and fissures in it.

Temperatures below $0\text{ }^{\circ}\text{C}$ in Szczecin during the hard winter months, cause the water absorbed by the material is frozen, and that causes a dilation of about 9% of the volume of the material, which causes appearance of cracks.

These low temperatures can also cause the expansion, by freezing, causing movement of parts, and consequently the appearance of fissures and even breaks in them.

On the other hand, in Valencia problems of materials are caused usually by high temperatures.

When there is a heat transfer to one material, this will undergo some changes as the internal energy increases. These modifications may include physical changes (of which the most important is the thermal expansion) or chemical changes. Furthermore the temperature will influence not only on the material but also on other elements associated with it.

When a material is exposed for a long time to very high temperatures it undergoes a volume increase known as thermal expansion.

We must take this into account because it is the source of many diseases in construction. To avoid possible damage is very important to know the coefficient of thermal expansion of the materials being used and build the necessary expansion joints to allow movement will inevitably suffer the construction.

CONCRETE

The manufacture of concrete with Portland cement, in extreme weather, whether high or low temperatures, directly influences the characteristics of the concrete for any process stage: kneading, installation of concrete or curing, as well as the physical and mechanical properties.

The following graphic shows how affects the ambient temperature in the concrete compressive strength, considering temperatures ranging from 5° C to 35° C, values for the limits to be considered as concreting in cold weather and concreting in hot weather.

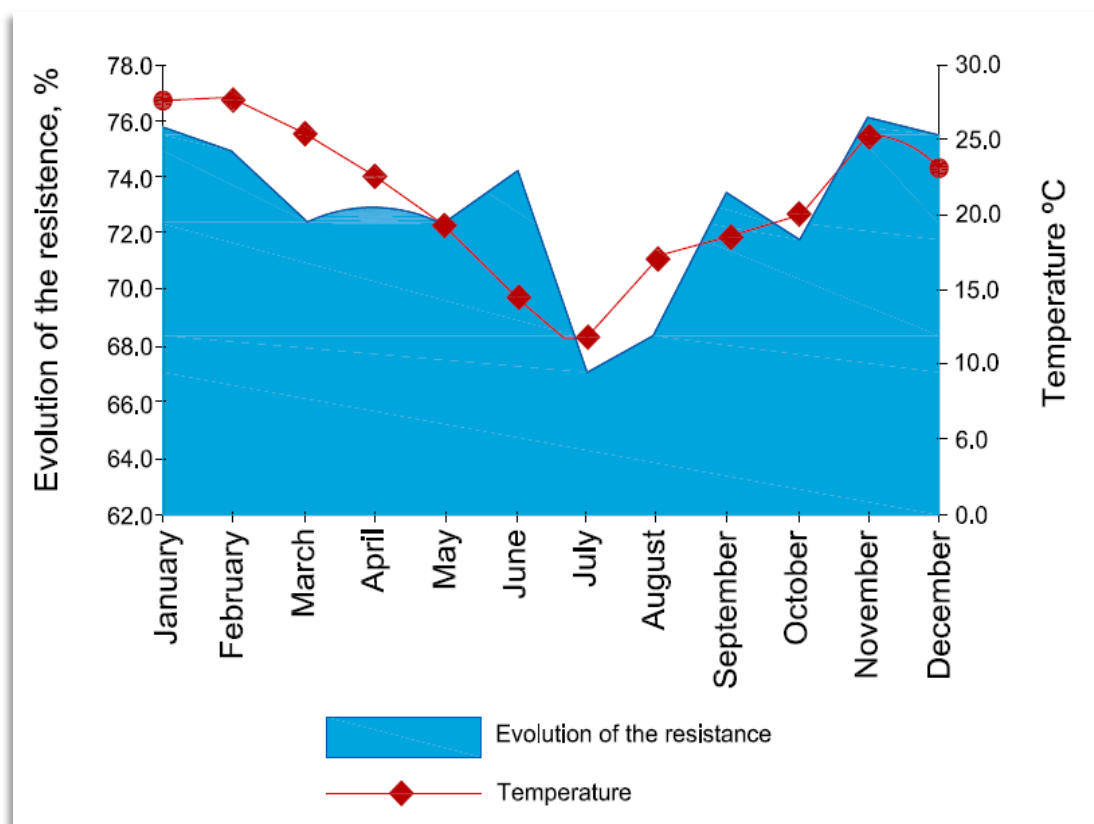

Graphic 4: Evolution of the concrete resistance. Source: www.registrocdt.cl

High weather

The effect high ambient temperatures on ready mix concrete (35 to 40 °C) is essentially due to factors, one technological and the other physical-chemical.

The technological factor is related to the water/cement ratio: when the temperature is high, much more water is obviously needed to attain and conserve concrete consistency. As a result, water is often added during casting (an operation known as retempering). Some studies have shown that the reduction in concrete strength due to the addition of water is proportional to the associated slump.

The other factor is microstructural and explains the lack of development of mechanical strength in 7- to 28-day old concrete when the temperature in the system exceeds the standard values is related to hydration reaction kinetics. The reaction rate is much greater, accelerating C-S-H gel (majority hydration product) formation. This, in turn, attenuates cement reactivity with respect to the formation of calcium silicate hydrates. The initial strength values rise substantially with increasing curing temperature, but end strength development is adversely affected.

- Increasing the cement dosage
- Raising the amount of mixing water
- Using retarding and water reducing admixtures
- Using fly ash
- Using blended and/or modified cements
- Cooling the aggregate
- Taking measures relating to production and logistics
- Optimizing the proportion of cement in the concrete depending on environmental conditions

Cold weather

Concrete transforms from a liquid to a solid material through a chemical reaction. The speed of the reaction depends upon the temperature of the concrete. When the weather is warm, the reaction proceeds quickly. When it's cold and the ground hasn't been thawed, the reaction slows down. That's the problem: the concrete needs to harden as rapidly as possible to resist pressures caused by water freezing within the concrete.

If the temperature is too cold, the concrete may not have reached a minimum strength of 500 psi soon enough to resist the effects of freezing temperatures. If your concrete isn't protected

with concrete curing blankets after it's poured, it may cool too rapidly, slowing the chemical reaction.

Poor finishing techniques can also doom your slabs. Freshly poured concrete often bleeds. The water in the mix floats to the top, since it's the lightest ingredient. Floating or troweling this water into the concrete weakens the top layer. Troweling the concrete too early can seal this bleed water just below the surface as well. If your slab is then exposed to freezing temperatures several days later, this water can freeze and fracture the top layer. Using a concrete curing blanket can eliminate the potential of freezing.

Concrete can be successfully poured in cold weather.

Several precautions need to be taken:

- Never pour concrete on frozen ground, snow, or ice. Use Powerblanket® concrete curing blankets for ground thawing ahead of time.
- Be sure to order air-entrained concrete. Request a heated mix or order 100 lbs of extra cement for each cubic yard of concrete. This extra cement helps develop early strength.
- Be sure the concrete is ordered with a low slump (drier mix). This minimizes bleed water.
- After the final finish is completed, cover the concrete with a Powerblanket® concrete curing blanket. The Powerblanket® concrete curing blankets will prevent freezing and keep the concrete at optimal curing temperature.
- After about 3 days, remove Powerblanket® curing blankets to allow the concrete to air dry.

STEEL

Ductility and toughness are two properties of the steel that are affected by the temperature.

We can assert that steel behaves more ductile during the summer season but loses much of its toughness or ability to absorb energy by deforming during the winter. This always depends on how much to increase or decrease the temperature

But the significant loss of strength for the construction steel will not begin until 400 ° C. So that its resistance is reduced to 50% is necessary for the temperature to rise to 600 ° C. At this temperature, their rigidity may be reduced about 70%.

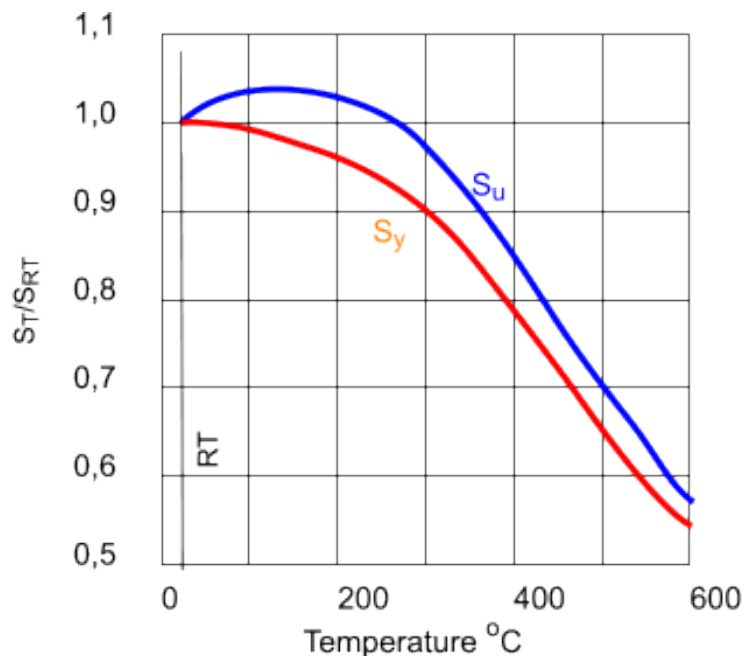

Variation of ultimate strength (S_u) and yield strength (S_y) with ratio of operating temp /room temp (S_T/S_{RT})

Graphic 5: evolution of the Steel resistance. Source: www.roymech.co.uk

As shown in the graphic, the decrease of strength because of the temperature in the steel is not alarming; it need too high temperatures to be produced the problem

However one of the problems which affects construction steel is corrosion.

The corrosion of structural steel is an electrochemical process that requires the simultaneous presence of moisture and oxygen. Essentially, the iron in the steel is oxidised to produce rust,

which occupies approximately six times the volume of the original material. The rate at which the corrosion process progresses depends on a number of factors, but principally the 'micro-climate' immediately surrounding the structure.

As previously mentioned humidity is one of the main causes that produce the corrosion. We can see the following graphic the difference of the relative humidity in Valencia and Szczecin. The relative humidity values are similar in the both cities but in Szczecin this values are a bit bigger than in Valencia.

In both cases relative humidity is high, so is necessary to take necessary actions to prevent this problem.

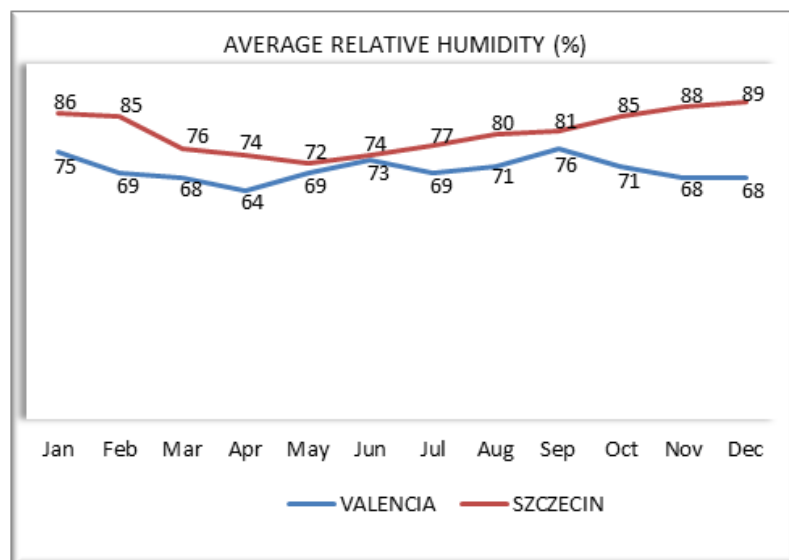

Graphic 6: Comparison of humidity. Source: Author

In a steel element when its temperature increases also increases the length and the volume, this phenomenon is called thermal expansion. If there is freedom of dilation there are no problems, but if this expansion is hindered by the other components of the structure shown supplementary efforts to be taken into account.

The steel and concrete expand and contract according a similar coefficient of expansion as is useful for simultaneous use in construction.



PREFABRICATED CONCRETE KERB

The behaviour of the street kerbs depends on the materials that they are composed, and being it made with very compacted concrete with high strength, we can deduce that it have the characteristics required to be considered a durability element.

Kerbs can support perfectly natural exposure as ice, rain and heat and can withstand extreme temperatures ranging from -30°C to 70°C . They are resistant to chemical spills and solvents in general (oils, greases, lubricants, fuels) substances time.

So we can say that the use of this type of material will ensure a great durabiliadad in any environment in which it is exposed.

5.4 EQUIPMENT USED

TECHNICAL DATA EQUIPMENT	
Name:	Wheel Loader
Description:	<p>Is a type of tractor that has a front-mounted square wide bucket connected to the end of two booms to scoop up loose material from the ground, such as dirt, sand or gravel, and move it from one place to another.</p> 
Technical datas:	<p>Operation weight: 10500Kg Engine power: 96kW/130hp Digging force: 89,9 kN Dumping height: 2700mm</p>
Rules for safe operation:	<p>The bucket shall not be used as scaffold or work platform. It will prevent that the bucket go above the people The bucket shall not be used to transport other materials than those set out by the manufacturer The bucket will not be charged beyond its working load The load will not be left in suspension In the absence of the driver It will prevent that the bucket go above the driver cab that is carrying The material shall be uniformly distributed in the truck, the load will not be excessive and it will be left on the truck with caution. The bucket left in the ground once the jobs are completed</p>
Maintenance rules:	<p>Hydraulic jacks should be placed on a firm basis and it shall have mechanisms to prevent a sudden drop The tire pressure should be checked prior to each use. The absence of cuts in tires shall be checked prior to each use.</p>
Personal Protective and Safety Equipments (PPE):	<p>Protection helmet Protective gloves against mechanical risks</p>
Marking:	

TECHNICAL DATA EQUIPMENT

Name: Dump truck

Description:

Is a truck used for transporting loose material for construction. It is equipped with an open-box bed, which is hinged at the rear and equipped with hydraulic pistons to lift the front, allowing the material in the bed to be deposited on the ground behind the truck.



Technical datas:

Maximum speed: 78 km/h
Payload capacity: 25000 Kg
Tank size: 260 liters
Curb weight 12050 kg
Dimension: 8472x2495x3400

Rules for save operation:

The box will be lowered immediately after the download has been effected
The entries and exits to the work will be done with caution, helped by a
If for any reason, the track need to stop on a ramp, the vehicle will brake.
It is expressly prohibited to carry the track beyond its working load than those set out by the manufacturer to prevent risk of overloading.
The driver will remain outside the cab during loading
Ensure that the load hauled on a truck or a truck-trailer is properly balanced and secured. If required, ensure that it is covered.
Obey established State and local speed limits. Adjust your speed according to driving conditions.

Maintenance rules:

Check the safety relief valve
Test the parking brake and service the brakes
The pressure and the absence of cuts on the tires should be checked prior to each use.
Check the manufacturer's and commercial driver's license brake test requirements and specifications.
Ensure that the vehicle is equipped with: Lights, reflectors, markers, flares or other authorized warning devices and chock blocks

Personal Protective and Safety Equipments
Protection helmet
Protective clothing
Safety shoes

Marking:





TECHNICAL DATA EQUIPMENT	
Name:	Breaker hammer
Description:	<p>Is a pneumatic or electro-mechanical tool that combines a hammer with a chisel. Large jackhammers, such as rig mounted hammers used on construction machinery, are hydraulically powered. They are usually used to break up rock, pavement, and concrete.</p>
Technical datas:	<p>Blows per minute 34 ft.-lbs Powerful : 1,450bpm Voltage: 120v Weight 35Kgs Overall length: 647mm</p>
Rules for save operation:	<p>Do not use machines or power tools in wet locations. Don't expose to Keep work area well lighted. Do not use electrically powered tools in the presence of flammable Do not force tool. It will do the job better and more safely at the rate for which it was intended. Do not use inappropriate attachments in an attempt to exceed the tool Use the right tool for the job. Do not use this tool for a purpose for which it was not intended.</p>
Maintenance rules:	<p>Maintain tools with care. Wipe the tool with a lint free cloth after each lubricate the Switch Follow instructions for lubricating and changing accessories. Inspect tool cords periodically and, if damaged, have them repaired by an authorized technician.. The handles must be kept clean, dry, and free from oil. Store in temperatures no lower than 50-60° F Check for damaged parts. Before using any tool, any part that appears damaged should be carefully checked.</p>
Personal Protective and Safety Equipments (PPE):	<p>Protection helmet Safety goggles/ Face shield Ear protection Protective clothing Safety shoes</p>
Marking:	



TECHNICAL DATA EQUIPMENT

Name: Truck mixer

Description:

Is a device that homogeneously combines cement, aggregate such as sand or gravel, and water to form concrete. It uses a revolving drum to mix the components.



Technical datas:

Volume: 7100 l
Water Tank: 300 l
Gross Vehicle Weight 25 T
Size of Mixer 5575x2300x2626
Power: 51 Kw

Rules for safe operation:

Never get between a pump/crane/bucket and a mixer truck.
Obey established state and local speed limits. Adjust your speed according to driving conditions.
When backing towards the pump hopper, the spotter must use clear hand
Never make contact with the truck and ground at the same time.
Stay away when the pipeline is being opened. If pressure remains when the pipeline is opened, concrete will be ejected with dangerous velocity.
If delivering at night, make sure to have proper lighting.
Set the parking brake before leaving the cab

Maintenance rules:

Verify the existence of a fire extinguisher in the truck.
Check that the maximum height of the truck is appropriate.
Keep clean acces, handholds and steps.
Daily cleaning of the truck and especially the inner and outer parts of drum.
Start cleaning at the top of the drum.
Ventilate the drum before entering.
Not do washing operations if there are power lines near.
Disconnect drum and cabin controls. Ensure that the drum does not rotate.
Verify that the truck can not boot

Personal Protective and Safety Equipments (PPE):

Protection helmet
Safety glasses
Ear protection
Gloves
Safety shoes

Marking:



TECHNICAL DATA EQUIPMENT

Name: Backhoe

Description:

A backhoe, also called a rear actor or back actor, is a piece of excavating equipment or digger consisting of a digging bucket on the end of a two-part articulated arm. They are typically mounted on the back of a tractor or front loader.



Technical datas:

Power: 71 Kw
 Max weight: 7958 Kg
 Load height: 3400 mm
 Dig depth: 4390 mm
 Reach at load height 2670 mm

Rules of use:

It will prevent that the bucket go above the people.
 The bucket shall not be used as scaffold or work platform.
 The bucket shall not be used to transport other materials than those set out by the manufacturer.
 The bucket will not be charged beyond its working load.
 The load will not be left in suspension In the absence of the driver.
 It will prevent that the bucket go above the driver cab that is carrying.
 The bucket left in the ground once the jobs are completed
 The material shall be uniformly distributed in the truck, the load will not be excessive and it will be left on the truck with caution.
 It will be maintained a minimum distance with power lines (5m)
 During the excavation, the extended stabilizers are placed and supported on firm ground.

Maintenance rules:

Hydraulic jacks should be placed on a firm basis and it shall have mechanisms to prevent a sudden drop
 The tire pressure should be checked prior to each use.
 The absence of cuts in tires shall be checked prior to each use.

Personal Protective and Safety Equipments (PPE):

Protection helmet
 Protective gloves against mechanical risks

Marking:



TECHNICAL DATA EQUIPMENT

Name: Welding machine

Description: Electrical device which transforms electric current by lowering the voltage of the supply network at a voltage and current suitable for welding.



Technical datas:
 Rated Input Voltage $415 \pm 15\%$ V
 Input Frequency: 50 Hz
 Duty Cycle: 60%
 Weight: 17.5 Kg
 Dimensions: 505 x 203 x 375

Rules for safe operation:
 Inspect cable, connections, and the amperage setting before starting the
 Do not harm the welding cables, electrode holder, ground clamp, or welding
 Stand on a dry surface when welding.
 Do not watch the electric arc without proper eye protection
 Weld in well ventilated areas to avoid toxic fumes.
 Before welding, make sure that the welding area is free of flammable
 Handle hot metal with pliers or tongs
 Prevent burns by cooling hot metal promptly, storing metal when not in use,
 and never touching the electrode or electrode holder to bare skin
 Use both hands to avoid fatigue.
 Dispose of electrode stubs properly to avoid falls and burns to feet.
 Do not allow the electrode to stick to the metal. If this occurs turn off the
 welder, allow electrode to cool, then break off with gloved hand.

Maintenance rules:
 Wipe up oil and fuel spills immediately
 Check valve clearance
 Check fluid levels (oil & fuel)
 Service the air filter (refer to engine manual for specifics)

Personal Protective and Safety Equipments
(PPE):

Protection helmet
 Heat resistant gloves
 Face shield
 Protective clothing
 Safety shoes

Marking:



TECHNICAL DATA EQUIPMENT

Name: Truck Mounted Crane

Description:(also called a loader crane or articulating crane) is a hydraulically-powered articulated arm fitted to a truck or trailer, and is used for loading-unloading the vehicle. The numerous jointed sections can be folded into a small space when the crane is not in use.



Technical datas:

Machine Weight: 800Kg
 Max Height with weight: 6,4m
 Max Radius with weight: 6m
 Stick: 3 section
 Moment: 42kN.m

Rules for save operation:

- Operate the crane safely handle without sudden movements.
- Knowing weight, maximum load and the load center of gravity to be lifted .
- Ensure good condition and enough space where the crane will be positioned.
- Ensure that a competent person tells signals.
- When you move the crane observe the existing traffic rules.
- Before lifting the load, ensure that they have been moored correctly.
- The load can't go above the people
- Ensure that there is no possibility of contact between any part of the crane or any obstacles. Nearby power lines require particular attention.
- Turn off and lock the machine when not in use
- Do not leave the hook extended and raised

Maintenance rules:

- Check that the tires are not worn and they are properly inflated
- Check that there is enough coolant
- Lubricate the parts according to the instruction manual
- Verify that the hook and accessories are properly installed and they haven't damages and leaks
- Verify that the lights and horn are in good condition.

Personal Protective and Safety Equipments (PPE):

- Protection helmet
- Protective clothing
- Safety shoes
- Safety gloves

Marking:



TECHNICAL DATA EQUIPMENT

Name: Total station

Description: Is an electronic/optical instrument used in modern surveying and building construction. It is an electronic theodolite integrated with an electronic distance meter to read slope distances from the instrument to a particular point. Robotic total stations allow the operator to control the instrument from a distance via remote control.



Technical datas:

Rotation speed:	45°/s
Scope:	Circular prism 3000m
	Prsim 360° 1500m
	Miniprism 1200m
Minimum distance:	1,5m

Rules for save operation:

- Do not look directly at the laser beam, as it can damage your eyes.
- Never use the telescope to observe an intense light like sunbeams reflected by a prism, as it may cause vision loss
- Do not disassemble, alter or repair this product
- Do not point the laser beam at persons, this can lead to severe eye damage
- Do not use a damaged power cable during charging.
- Do not use the battery or charger if they are wet because an unsafe installation could cause it to fall down and injury may result.
- Never carry the instrument on the tripod



Maintenance rules:

- Check regularly that there are not any humidity or dust particles inside the
- Always clean the instrument before storing. First brush the lens to remove dust then causes a small condensation by breathing on the lens, rub it in lightly with a damp cloth
- Do not use organic solvents to clean the instrument
- The case must always be closed to prevent humidity
- If the instrument was inactive for too long, maintenance checks at least every three months

Personal Protective and Safety Equipments (PPE):
Protection helmet

Marking:



TECHNICAL DATA EQUIPMENT	
Name:	Welding machine
Description:	<p>A ballast tamper or tamping machine is a machine used to pack (or tamp) the track ballast under railway tracks to make the tracks more durable. Also correct the alignment of the rails to make them parallel and level, in order to achieve a more comfortable ride for passengers and freight and to reduce the mechanical strain applied to the rails by passing trains.</p>
Technical datas:	<p>Vibration frequency 30–35 Hz Working speed: 1–2 km/h Vertical pressure applied: 100 kg/cm²</p>
	
Rules for save operation:	
<p>Working with with the cabin closed. Make total breaking only in a emergency Never drive on slopes without wearing a adequate speed Never disconnect the engine until the machine is completely stopped You have to drive quite carefully It is strictly forbidden to board or alight while the machine is in motion</p>	
Maintenance rules:	
<p>Check combustibe deposits, oil and other liquids Lubricate all devices and levers Check the brakes and lighting installation Check the pressure of the nitrogen accumulator Periodically review the functioning of the extinguisher Replace the hoses according to the manufacturer's instructions Clean up oil or fuel spills, do not allow the accumulation of flammable materials in the machine</p>	
Personal Protective and Safety Equipments (PPE):	Marking:
<p>Protection helmet Protection gloves Abdominal belt vibration Protective clothing Safety shoes Ear protection</p>	



TECHNICAL DATA EQUIPMENT									
Name:	Asphalt milling machine								
Description:	<p>Is a type of grinder specifically made to grind and chew up asphalt of many sizes. The purpose of an asphalt milling machine is that, by reducing large pieces of asphalt to a coarse powder, asphalt can easily be recycled.</p>								
Technical datas:	<table style="width: 100%; border: none;"> <tr> <td style="padding-right: 20px;">Milling Width:</td> <td>2.00 m.</td> </tr> <tr> <td>Milling Depth:</td> <td>0 – 320mm</td> </tr> <tr> <td>Engine power</td> <td>433 kW / 589 HP</td> </tr> <tr> <td>Operating Weight:</td> <td>30,000 kg</td> </tr> </table>	Milling Width:	2.00 m.	Milling Depth:	0 – 320mm	Engine power	433 kW / 589 HP	Operating Weight:	30,000 kg
Milling Width:	2.00 m.								
Milling Depth:	0 – 320mm								
Engine power	433 kW / 589 HP								
Operating Weight:	30,000 kg								
Rules for save operation:	<p>Controlling the machine only from the driver's seat. It can not be used to transport people Not to mount or dismount when themachine is moving When working on slopes, you have to work longitudinally, never across. Use the lowest gear on slopes of more than 7%. In transport operations, check if the length and blocking system are Parking the machine in flat areas with solid ground, safe from crashes or floods. You have to put on the brakes, remove the keys, close the battery switch, close the cab and engine compartment. Adjust the seat and controllers to the appropriate position. Always ensure communication between the driver and the foreman.</p>								
Maintenance rules:	<p>Verify the existence of a fire extinguisher in the router. Check that all labels of risk information are in good state. In maintenance operations, the machine must be parked on level ground, the brake engaged, the transmission lever in neutral point, the engine stopped and the battery switch in the off position. The waste generated as a consequence of a breakdown must be segregated in containers. If the instrument was inactive for too long, maintenance checks at least every three months</p>								
Personal Protective and Safety Equipments (PPE):	<p>Protection helmet Protective clothing Safety shoes Safety gloves</p>								
Marking:	CE								



5.5 EXECUTION PROCESS

1. PREPARATORY WORK
 - 1.1. REMOVAL OF TREES AND SHRUBS.
 - 1.2. LEARING THE LAND
 - 1.3. DEMOLITION OF ROAD
 - 1.4. REMOVE THE TRAM TRACKS
2. EXECUTION OF THE UNDERGROUND INSTALLATIONS
3. EXCAVATION
4. DRAINAGE ELEMENTS
 - 4.1 SEWER AND CATH-BASIN
 - 4.2 FILTERS
5. FILTRATION LAYER
6. GEOTEXTILE
7. CLEANING
8. GRAVEL AND SAND BASE
9. CRUSHED GRAVEL BASE
10. PLACEMENT OF TRAM TRACKS AND SLEEPERS
11. TOP LAYER WITH BALLAST

PREPARATORY WORK

1. Equipment

To perform the removing trees and shrubs should be used:

- Saws
- Special machines designed for removing tree trunks and its removal
- Bulldozers
- Excavators, tractors with special arrangements for work associated with deforestation

2. Transport

The stems and branches will be transported by road.

The trunks with value for reuse (for example for construction, furniture, etc.) must be transported carefully for not cause its damage

3. Execution

The works associated with the demolition of trees and shrubs include cutting and removing trees and shrubs, the transport outside the work, filling the holes and possible elimination of other waste with fire.

All trees and shrubs located within the excavation areas will be removed.

Before the removal of trees and shrubs should have signed an authorization permitting it.

If the vegetation preserved, is damaged or destroyed shall be restored by the Contractor.

4. Quality control

Checking the quality of work is based on a visual assessment of the total removal of vegetation, roots and filling the holes.

The land has been poured for the filling of the holes should be compacted in compliance with the requirements.

LEARNING THE LAND

1. Equipment

For the execution of works related to the removal of humus that cannot be reused should be used:

- Bulldozers
- Shovels and other manual equipment for moving the land (in areas where the correct execution with mechanical equipment is not possible)
- Excavators and dump trucks (for transport to a distance that requires use of such equipment.)

For the execution of works relating to the removal of humus that can be reused should be used:

- Lawn mowers
- Shovels.

2. Transport

The humus must be moved using a motor grader or bulldozer or transported by car.

The choice of the means of transport depends on the distance. It must be transported by road.

3. Execution

This work includes the removal of the surface layer

The thickness of the humus layer that it will be removable must be adjusted as indicated in the project.

Once removed the humus should be stored in regular piles. The storage space of humus should be selected to protect it from contamination.

You can't make the humus removal operations during heavy rains or at later times because this could be contaminated.

4. Quality control

Checking the quality of work is based on a visual assessment of the integrity of the removal of topsoil and grass.

DEMOLITION OF ROAD

1. Equipment

For the execution of works relating to demolition of roads can be used:

- Bulldozers
- Charger
- Cranes
- Trucks
- Hammers
- Saws
- Milling
- Excavators.

2. Transport

The demolition material can be transported by any means of transport.

3. Execution

All materials that can be recycled should be treated without causing any damage.

In areas where there are holes and there aren't expect excavation work, it shall be filled to the correct height, compacting each layer in compliance with the requirements.

4. Quality control

The quality control work involves visual assessment of the integrity of demolition and check the extent of damage from elements intended for reuse.

Soil compaction must comply with the requirements.

REMOVE THE TRAM TRACKS

1. Equipment

For the execution demolition works of the tram tracks can be used the equipment listed below:

- Bulldozers
- Charger
- Cranes
- Trucks
- Pneumatic hammers
- Chainsaws
- Milling
- Excavators

2. Transport

The demolition material can be transported by any means of transport.

3. Execution

The demolition of the tracks includes the demolition of:

- Pavement Layers
- Curbs
- Rails
- Sleepers
- Draining

All materials that can be recycled should be treated without causing any damage.

In areas where there are holes and there aren't expect excavation work, it shall be filled to the correct height, compacting each layer in compliance with the requirements.

4. Quality control

The quality control work involves visual assessment of the integrity of demolition and check the extent of damage from elements intended for reuse.

Soil compaction must comply with the requirements.

EXECUTION OF THE UNDERGROUND INSTALLATIONS

In addition to the reconstruction of the tram tracks, on the Potulicka street, also is projected the renovation of all types of underground installations as: electrical and telecommunications line, water and gas line and sewerage network.

Once you have removed all the material of the driveway, these installations will be executed. As these activities are not the subject of our study, we won't develop it.

EXCAVATION

1. Equipment

The equipment used for this phase will depend on the type of activity:

- To break the land: machine-tools, hammers, traction machine, excavators, loaders, power drill, etc...
- For extraction and earthmoving: bulldozers, scrapers, graders, etc...
- To transport the land: trucks, conveyors, etc...
- For soil compaction: rollers, road rollers, vibratory plates, etc...

2. Transport

The choice of means of transport must be adapted to the type of the land, its volume, charging technology and transport distance.

3. Execution

3.1 - Drainage during earthmoving: independently of the construction equipment that it is using is necessary to incorporate drainage equipment because the elevation of the water table is very high.

3.2 - Drainage ditches: The trench should be able to provide adequate drainage during the works. Its transverse gradient should not be less than 4%. Landslides must be taken into account

3.3 - Trench: trench must be made in accordance with the design documentation. El ancho y la profundidad de la zanja no debe superar en más de 5cm a los valores indicados en el proyecto

4. Quality control

Checking the gas drainage, rainwater and wastewater

The width of the bottom part of the trench may not differ from the project by more than 5 cm.

Elevations may not differ from the project by more than -3 cm or 1cm .

The inclination of the tracks cannot differ by more than 10% of the slope indicated in the project.

Soil compaction must comply with the requirements.

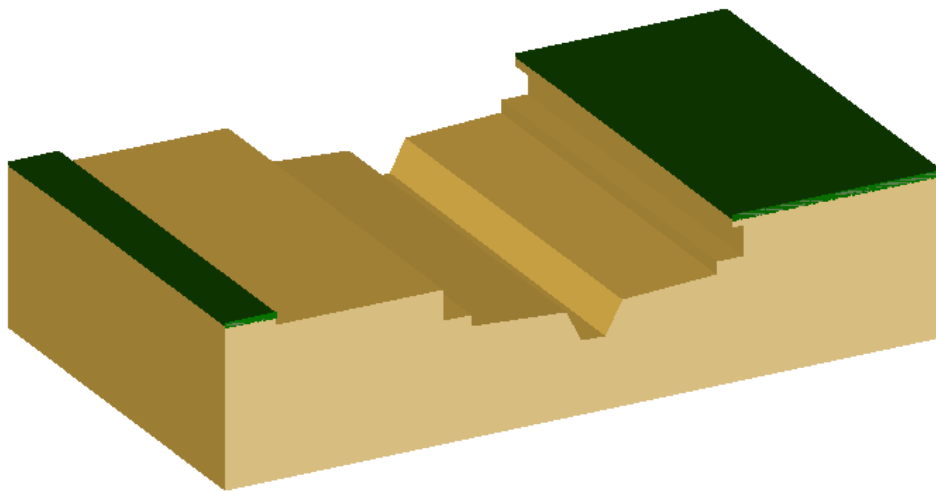

DRAINAGE

1. Materials

The materials used for construct the sewer are:

- Concrete
- Insulation Materials
- Formwork and reinforced concrete structures
- Prefabricated concrete elements

1.1 Concrete and its components: It will use concrete B 30 for prefabricated elements, front walls and sewers, and the concrete B25 for the protective layers. Concrete must comply the following requirements:

- Absorption of not more than 4%,
- Water permeability - level of water resistance more than 8
- Frost resistance more than 150 f

Use only Portland cement (no additives). Concrete class B 25, B 30 and B 40

Water: without laboratory tests you can be used drinking tap water. The water from questionable sources can not be used.

1.2 Insulation Materials: to isolate road sewers and external concrete walls can be used the following materials:

- Asphalt primer
- Glue on hot asphalt without fillers
- Role of asphalt
- Any other insulation material that has been approved as technical testing verified.

1.3 Elements of formwork and reinforced concrete structures

1.4 Prefabricated concrete elements: the surfaces of the elements must be smooth and without fractures, air bubbles and water cannot have more than 5 mm deep.

2. Equipment

You can use the following equipment:

- excavator
- Equipment for manual preparation of shallow trenches
- Truck Cranes
- Mixers
- Other transport equipmentTransport

3. Transport

Transportation of cement should be adequate to provide the necessary protection from contamination, mixed with other materials and humidity

The time of the concrete transport should comply the requirement of changing the consistency of the mixture obtained acceptable preparation.

The wooden elements and formwork must be transported in conditions that protect them from displacement, corrosion and mechanical damage.

FILTERS

Filters are used to facilitate the flow of water to a drain.

1. Materials

Types of materials used:

- Drain plastic tube: they must be protected against mechanical forces at temperatures below 0 ° C. The accessories for connection of drain pipe must be made of high pressure polyethylene.
- Natural gravel with size larger than the drain holes to prevent clogging grain.
- Coarse sand, diameter of grains of 2 mm

2. Equipment

A filter can be installed manually or mechanically, but usually due to the small size of underground drainage, the installation will be manually.

3. Transport

The drain pipe can be transported by any means of transport, they are usually supplied on pallets.

The loading and unloading of the tubes should be conducted using devices with mechanical grippers.

Plastic pipes should be protected from slipping.

4. Execution

Before installing drainage pipes It Should clean the bottom of the trenches.

Is recommended to place the drainage tube immediately after excavation of the trench to reduce the risk of landslides.

Cover the tube (with a stone or a plastic) to prevent the entry of sand particles inside the tube.

Once the tube is placed, the pipe will be filled. Filling should be done in a way that does not cause damage to the pipe. After placement of the pipe make the filling of the gravel. This gravel should exceed the tube by more than 10 cm. After compacting the gravel on both sides and place layers of filtration material with thickness less than 20-25cm.

Tolerances of the filter length are:

- Variations in the dimensions of width and depth of the trench: not more than 10 cm
- Slope of the excavation slopes should not differ by more than 5%
- Deviations away from the axis of the pipe should not exceed 5 cm
- Thickness of the filter layer: 5 cm

5. Quality control

Each pipe should be examined. Check the smoothness of its surface without blisters.

Examination of gravel and sand includes checking each batch of supplies from a composition and size of up to 1500 t:

Checking the filter in the longitudinal direction:

- Correct implementation of ballast
- Drain tube placed correctly
- Adequate execution of the filter filling
- Adequate execution of the outbound drain

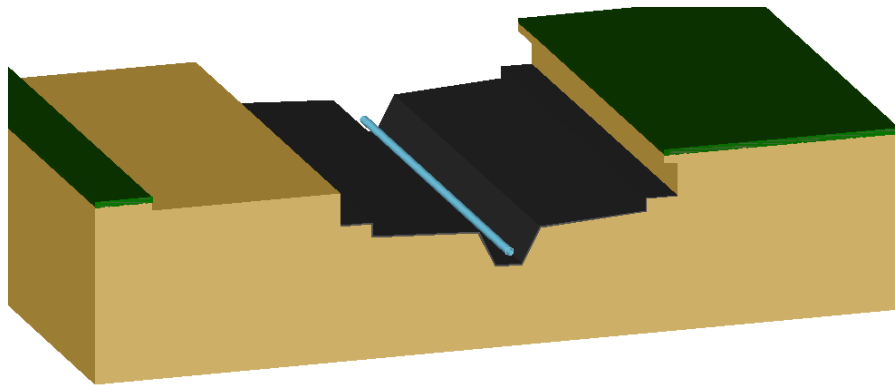

EXECUTION OF THE LAYERS

FILTRATION LAYER

1. Materials

The materials used in the performance of taps and layers are:

- Sand
- Gravel
- Geotextile

2. Equipment

The equipment for execution of works are:

- Static roller
- Vibration plate or mechanical tampers

3. Transport

Transportation of sand and gravel should be adequate to provide the necessary protection from contamination, mixed with other materials, humidity and dryness.

Geotextiles can be transported by any means of transport but they must go wrapped to prevent contact with chemicals and protected from humidity and excessive heat.

4. Execution

4.1 - Preparation of the substrate

4.2 - Addition and compacting of the aggregate

The aggregate shall be spread in a layer of uniform thickness

Immediately after placement the filtration layer it must proceed to its compaction.

If there are bulges or depressions during compaction should be eliminated by the addition or removal of material to obtain a flat surface.

In inaccessible areas to rollers, the filtration layer areas should be compacted by mechanical or vibratory plate compactors.

Humidity during compaction of the aggregate should be equal to the optimal humidity, with a tolerance of -20% to 10% of its value. When the humidity is higher than the optimal humidity,

the aggregate should be dried by agitation and aeration. If the humidity is lower than the optimal humidity, must be wet with water and mix uniformly

4.3 - Checks

The Contractor shall perform a test in order to:

- Determine if the construction equipment for spreading and compacting is correct,
- Determine the thickness of the layer of material in uncompressed state. It is necessary to achieve the required thickness after compaction,
- Determine the number of passes of the compaction equipment is necessary to achieve the required rate of compaction.

4.4 - Placing the geotextile

Before placing of the geotextile shall be verified that there is no sharp object.

Extending the geotextile in the direction of the construction progress completely flat without wrinkles. In case of need to add new adjacent geotextile, these should superimpose (overlap).

When geotextiles have been placed on the ground, this should be covered as soon as possible to prevent degradation caused by UV rays or other external agents, trying to avoid outdoor exposure over 3 days.

5. Quality control

Geotextiles designed for the filtration layer must have the technical approval

The thickness of the layer of aggregates can not be different from the width of the draft of more than 10 cm, -5 cm.

The differences between the ordinates and elevations in heights should not exceed 1 cm and -2cm²

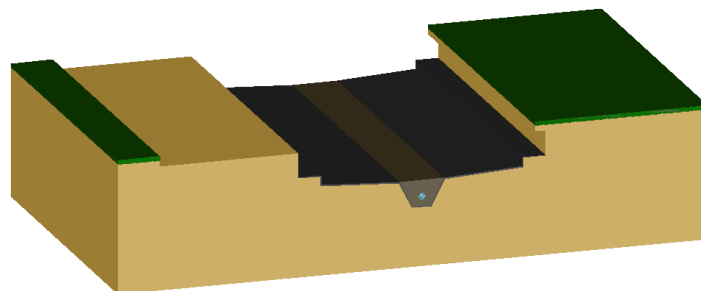

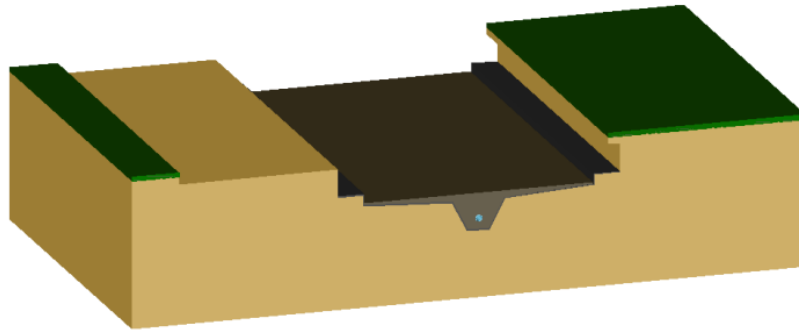

GEOTEXTILE

During the execution process we are used two types of geotextiles

- Separation geotextile filter 35/35
- Reinforcement geotextile 46/46

1. Materiales

Geotextile

For filtration-separation layers and reinforcement layer should be used geotextiles 35/35 and 46/46, which must have the requirements.

Filter layer will protect the drainage layer and will separate filter layer from crushed stone foundation.

The geotextile should be made of 100% of polypropylene. The geotextile should be resistant to chemical elements that are naturally in soil and water, weather conditions and UV rays.

Rolls of geotextile should be wrapped in black plastic to protect them and each roll must be labeled with the following information: name of the product, address of the manufacturer, date of manufacture and size.

Geotextile rolls shall be stored horizontally on a flat and dry surface. The rolls should be protected against humidity, high temperatures, solar radiation, chemicals products, grease, fuels, lubricants and the possibility of mechanical damage.

Steel buckles

Assembly: U-shaped, is a smooth steel with a diameter of 8 mm and a length of 25-35 cm. It be placed every 10-15 cm. These clamps are used to anchor the geotextile.

2. Equipment

The placement of the geotextile is usually done manually to prevent damage. For placement only need the following equipment:

- Lightweight Excavators
- Chargers
- Hammer

3. Transport

The Geotextiles can be transported by any means of transport in the original packaging.

The geotextile are usually supply in rolls. To transport the rolls, they should be placed on smooth surfaces and should not be piled more than 5 rolls.

During transport and storage the geotextile roll shall be protected against the possibility of mechanical damage, sunlight, high temperatures, water splashes, contact with chemicals products, fuel, grease and fats.

4. Execution

Before placing of the geotextile shall be verified that there is no sharp object.

Extending the geotextile in the direction of the construction progress completely flat without wrinkles. In case of need to add new adjacent geotextile, these should superimpose (overlap).

When geotextiles have been placed on the ground, this should be covered as soon as possible to prevent degradation caused by UV rays or other external agents, trying to avoid outdoor exposure over 3 days.

After placement of the geotextile traffic is not allowed on this as it could be damaged.

5. Quality control

Before placement must verify that the material is undamaged and complies with all requirements.

After placement it must check to verify proper placement, position, and smooth surface, without cracks.

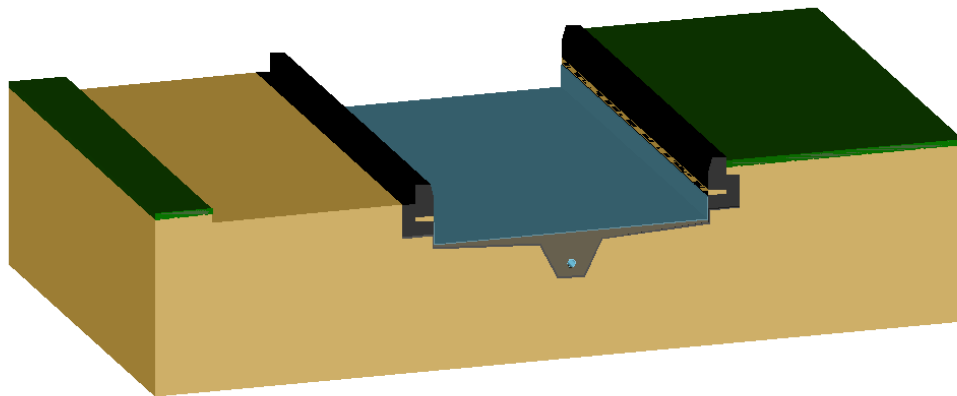

CLEANING

Activities relating to the cleaning before placement of the next layer include; cleaning of the bitumen based and cleaning of the lower layer of mechanically stabilized aggregate base.

1. Materials

Asphalt emulsion with properties ZM C60 B5. To ensure that the product meets the requirements, it should be carried out the control of factory production, which must be certified by a notified body (CE marking) or by an accredited body.

2. Equipment

To clean the surface layers is used the following equipment:

- Compressor
- Water tanks
- Brush (for manual brush)

To cleaning top layers, It use water spray equipped with devices to measure the temperature, pressure, speed of movement of the spray, the amount of adhesive dispensed:

The cleaning involves removal of loose material, dirt, mud and dust. It can use mechanical brushes, and if required, pressurized water. In areas with difficult access, use manual brushes.

3. Execution

Before the start of the activity, the contractor should be ensured that rains are not expected because the surface must be dry and free of humidity

The spraying will distribute in a uniform way.

Then spray a bituminous asphalt emulsion. The temperature of the asphalt emulsion should be between 20 and 40 ° C.

4. Transport

The emulsion can be transported in tankers, barrels and other containers that protect the material from corrosion and contamination.

The tanks must be divided into compartments of not more than 1 m³, and should have holes to allow the flow of the emulsion. Cisterns and tanks must be clean.

The water transport should be done in a tank truck.

5. Quality control

Check that the material meets all the requirements. Verification of the homogeneity.

GRAVEL AND SAND BASE

1. Materials

Filtration layer includes:

- Gravel
- Sand

To improve the properties of the aggregates it is used:

- Cement portland
- Fly ash
- Granulated Slag

The use of other adhesives approved by technical services are allowed

Water should be used according to the regulations.

2. Equipment

For the preparation of homogeneous mixtures with optimum moisture content, the following equipment is used: Rollers on tires and vibrator. In places inaccessible plate compactors, rammers or mechanical vibration should be used.

3. Transport

Transportation of sand and gravel should be adequate to provide the necessary protection from contamination, mixed with other materials, humidity and dryness.

4. Execution

4.1 - Production of aggregates

The aggregate mixture is performed in a mixer to assure adequate size of the particles and control the humidity of the mix, ensuring a perfectly homogeneous mixture.

4.2 - Addition and compaction of the mixture

The aggregate mixture should be distributed in a layer with uniform thickness. The thickness of the layer should not exceed 20 cm after compaction.

The humidity of the aggregates mix during the compaction should correspond to the optimum humidity.

4.3 - Maintenance of the layer

The substructure after and before placing the next layer should be kept in good condition

5. Quality control

Before the works, the Contractor shall check the compaction of underlays

Testing during construction

- The maximum grain size of the mixture must meet the requirements.
- The humidity of the mixture should correspond to the optimum humidity content.
- The width of the substructure cannot differ from the project more than 10 cm, -5 cm.
- The differences between the heights of the substructure and projected elevations should not exceed +1 cm, -2 cm.
- The axis of the base cannot move by more than 5 cm.
- The thickness of the substructure cannot differ from the designed thickness of more than 10%
- Check the load capacity of the layer

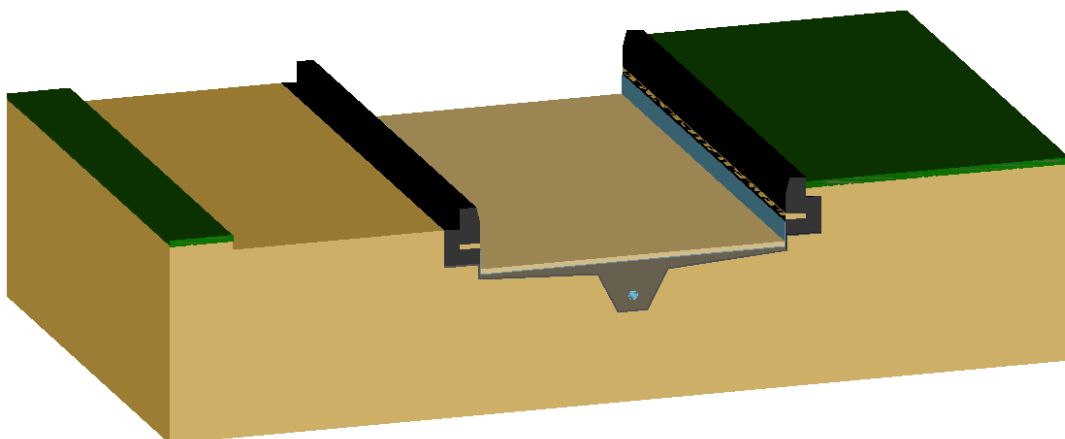

CRUSHED GRAVEL BASE

1. Materials

The material for the application of the crushed aggregate must be mechanically stabilized. It is formed by broken boulders, pebbles and grains of gravel, with diameters $\geq 63\text{mm}$

The aggregate mix shall be uniform and free of impurities.

Aggregate shall meet the specified requirements.

2. Equipment

For the preparation of homogeneous mixtures with optimum humidity, the following equipment is used: Rollers on tires and vibratory.

In inaccessible places, plate compactors, rammers or mechanical vibration should be used.

3. Transport

The aggregates can be transported by any means of transport under conditions that protect them from contamination, mixed with other materials, excessive dryness and humidity.

The transport of other materials shall be in accordance with applicable regulations.

4. Execution

Incorporation and compaction of crushed gravel.

The thickness of the crushed gravel layer must be adequate to ensure that when compacting, this layer complies with the measures designed into the project. The gravel must meet the following requirements:

- The fill layer should be uniformly placed
- The material used must meet the requirements of product standards
- The layer thickness tolerance is $\pm 0.02\text{ m}$

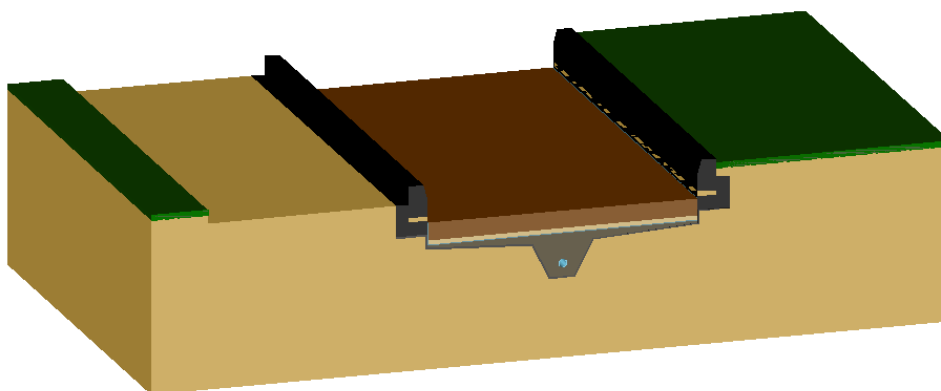

TRAM RACKS AND SLEEPERS

The works include all activities to complete finishing of roads as switches and other elements of the surface of the tram line.

Following placement of grooved rails supported on an elastic band on the prestressed concrete sleepers are described.

1. Materials

The used materials are

- Welding materials
- Profiles of rubber (vibration insulators)
- Accessories for mounting rails
- Pads HDPE
- Rail lubricators
- Electrical connectors
- Drains PE double wall
- Geotextile separator filter
- Reinforced geotextile separator

Rails

Throat rails will be used: 60N Ri profile. The length of the individual sections of the embedded rail track shall not be less than 12.00 m.

The crossbars will have a diameter of 25 mm, each one separated 3.0 m in each straight section and 1.5 m on curves.

Welding

The joints between rails are made using thermal aluminium welding. This type of welding confers high hardness to the junction area, similar to the rest of the rail.

Otros materiales como: Interruptores, sujetadores ferroviarios eléctricos, accesorios para los rieles de montaje, arandelas HDE, lechada de cemento, lubricante para engrasar la pista, cajas de drenaje y materiales para la deshidratación de la pista.

2. Equipment

The operations of positioning the tram tracks will be used the following equipment:

- Machines for the thermal welding
- Welding equipment for welding gas
- Loader cranes up to 20 tonnes
- Transportable boiler to heat the bitumen
- Electric drill
- Three-phase generator.

3. Transport

During transport, tram tracks should be protected against curvature, torsion etc.

The surface of rail elements will be downloaded by lifting to avoid deformation. Switches and their parts must be stored properly, that is, they must be on a flat and hard surface.

4. Execution

4.1 - Substrate Preparation

The contractor shall ensure that during execution the drainage works properly and there is no high humidity to decrease the required capacity of the substrate.

4.2 - Installation of tracks

First the sleepers will be placed. Over they will be fixed the rails by SB 4 connectors. The sleepers will be placed every 67 cm.

The elastic material will be placed in the base of the rails. For fixing this material will be performed according to the manufacturer's recommendations.

5. Quality control

Checking is made by visual inspection of all components of the tram and comparing the results with the design documentation.

The tests to be performed are:

- The runway should not have a shaft deflection bigger than 1 cm every 1000 m.
- The deviation of the track width of ± 2 mm
- The deviation curves cannot exceed 4 mm in the centre of the arc
- The rails must be fixed properly not allowing its movement

- The surfaces of the head rail, in solder area should be sanded to shape, clean and mold. The lack of metal in welding may fracture the union. Assess if there are pinholes and bubbles in the weld zones.
- Check the camber curves on the track at intervals of 10 m

Other Checks: width and depth of the groove, the length and slope of the ramps, the length of the support plate, distance between the rails and tracks...

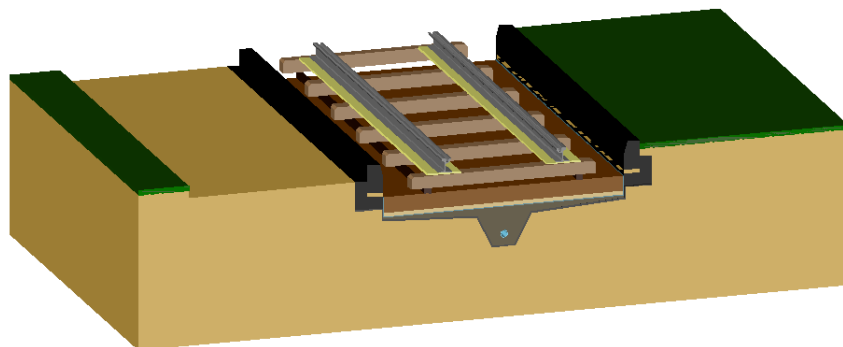
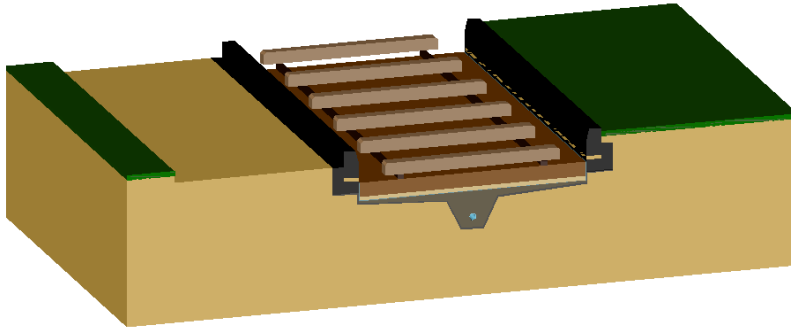

TOP LAYER WITH BALLAST

The surface layer of the structure is forming by the ballast. It may be formed of recycled material.

1. Materials

The material for the application of the crushed aggregate must be mechanically stabilized. It is formed by broken boulders, pebbles and grains of gravel, with diametres +63mm

The aggregate mix shall be uniform and free of impurities.

Aggregate shall meet the specified requirements.

2. Equipment

The equipment used for this work is:

- Vibratory plate compactor. The pressure per unit must be at least 16 kn/m²
- Tank to transport water
- Tankers for filling with water.

3. Transport

The aggregates can be transported by any means of transport under conditions that protect them from contamination, mixed with other materials, excessive dryness and humidity.

The transport of other materials shall be in accordance with applicable regulations.

4. Execution

The thickness of the crushed gravel layer must be adequate to ensure that when compacting, this layer complies with the measures designed into the project. The gravel must meet the following requirements:

- The fill layer should be uniformly placed
- The material used must meet the requirements of product standards
- The layer thickness tolerance is ± 0.02 m

. The top layer covering the tracks and profiles of the rails must be aggregated with granulation size between 25 mm and 40 mm.

5. Quality control

Before the placement of the ballast must ensure that the compaction of the base layer is adequate and it is in good condition.

It should make at least one test every day (with maximum area of 600 m²) of: abrasion, water absorption of aggregates and frost resistance.

Tests and measurements of geometric features

- The permissible deviation of layer thickness should not exceed 10%
- Other geometric characteristics of the layer should be measured and evaluated.

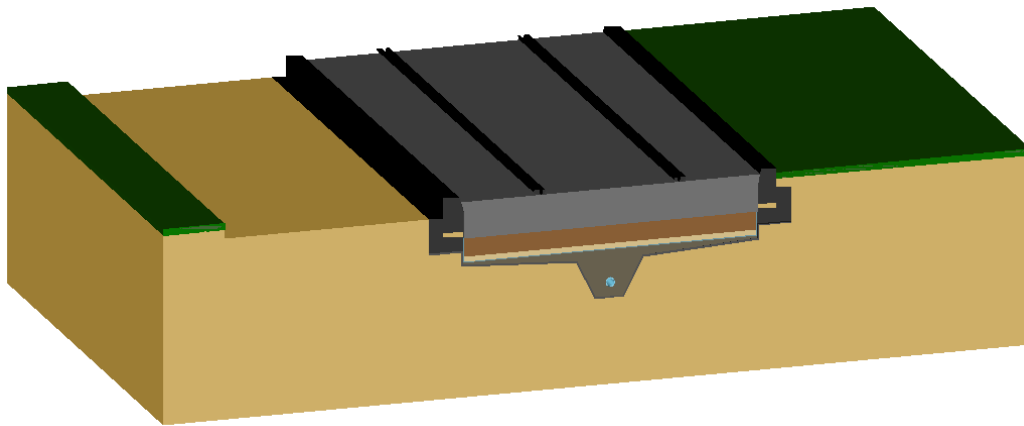

CHAPTER 6:
STATE OF
CONSERVATION

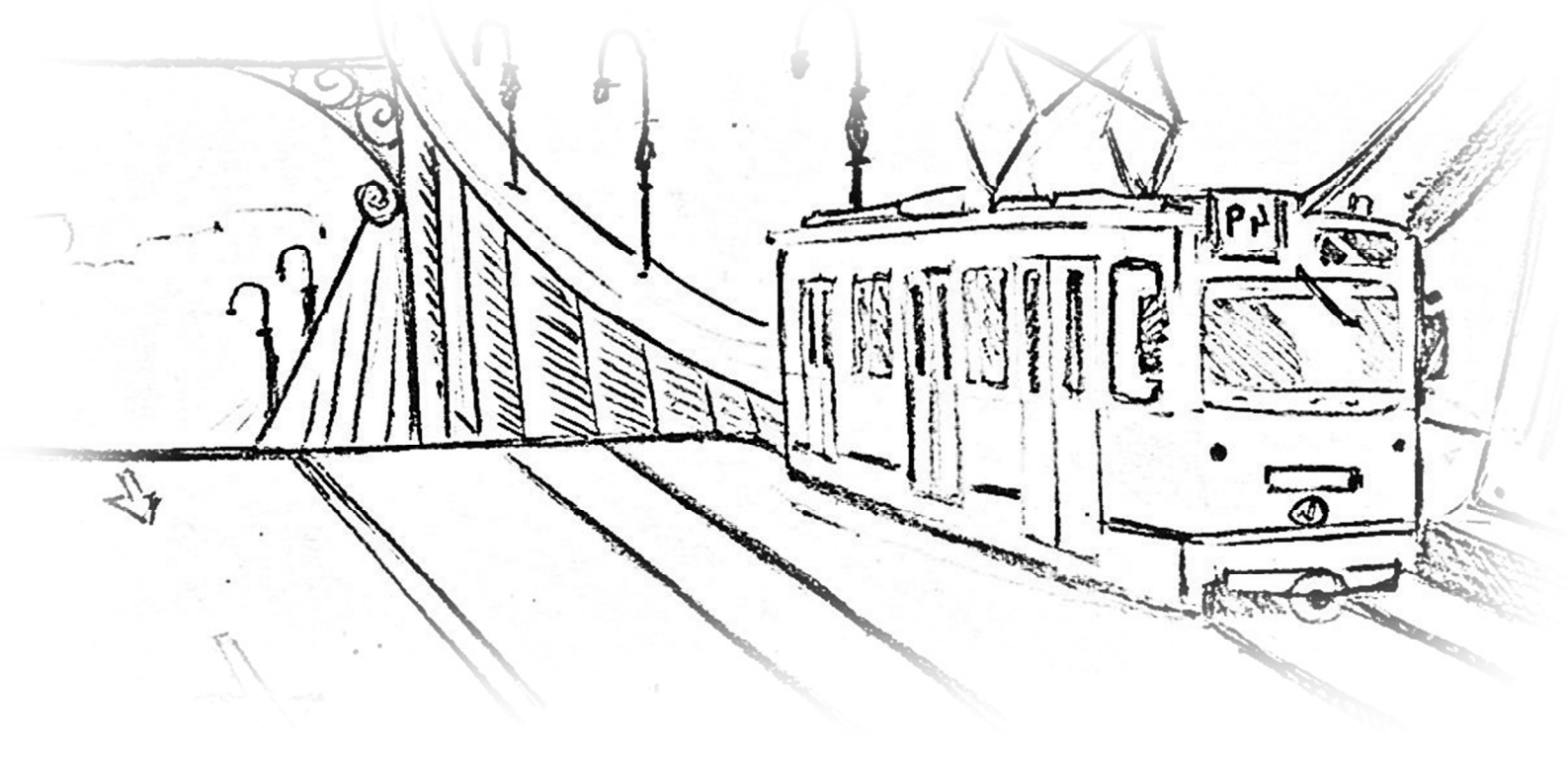

DAMAGES

CORRECTIVE/CORRECTING MAINTENANCE

INSPECTION SHEET. DATA COLLECTION

KIND OF LESION:

Defects in the pavement located beside the tram tracks

LOCATION:

St. Potucka, Szczecin

DATE:

28/03/2014

Nº PICTURES:

2

PICTURES:



DESCRIPTION OF LESION:

As can be seen on the pictures, there are serious damages on the cobblestones located near the tram tracks

- 1.- Lifting and sinking of the cobblestone placed around the tram tracks
- 2.- Disintegration, erosion and abrasion wear of the road surface, causing loss of its original volume and exterior finish and eroded tile edges.
- 3.- Disappearance of the elastic material that there should be between the tracks and pavement
- 4.- Presence of organic elements such as plants or mold in the joints of the pavement.

DANGER OF LESION:

Nothing
 Less
 Medium
 Dangerous
 Very dangerous

POSSIBLE CAUSES:

The expansion and contraction of the metal profile of the track caused by the temperature changes produce an increase and decrease in its volume, this causes tensions in the pavement in contact with the tram tracks. The thrust produced by the tram track to the pavement causes movement of the cobblestones

The absence or deterioration of the elastic joint between the pavers and tram tracks. The presence of elastic material that absorbs the expansions and contractions of the tracks is necessary.

The sinking of the tiles can be also for the compression of the sand bed. This occurs when it is mechanically weak because lack of compaction in the execution process or by a patchy distribution of the sand bed. Another possible cause overloading of use is because in these street circulates all kind of heavy vehicles in addition of trams.

The appearance of organisms in the joints of the pavement is due to water or dampness accumulation in these areas. These microorganisms and plant parasites deteriorate the surface layers of the pavement.

Water from rain, hail or snow hits the pavement, wears the material and causes pilling and particledrag.

DIAGRAM:

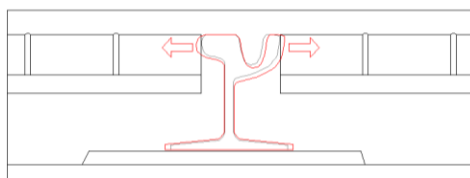

Dilatation. Increase in volume.

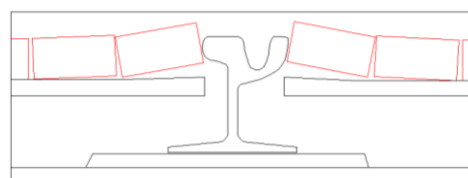

Lifting of the cobblestone

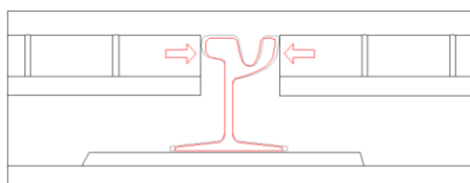

Contraction. Decreased involumen

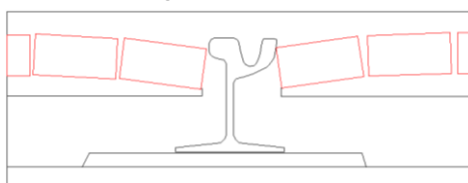

Sinking of the cobblestone

OBSERVATIONS:

When heated, the rails are lengthening in just over one hundred thousandth of its length for each degree centigrade. During hot summer days, the rails can become heated to 30, 40 or more degrees. The winter frost cooled these rails to temperatures of -25°C and lower.

DESCRIPTION OF THE POSSIBLE INTERVENTIONS:

The main cause of this pathology is the absence of the separation joint between the pavers and tram tracks, necessary for the absorption of the movements caused by the rails. For its placement is necessary:

- 1 - Removing all the layer formed by the cobblestones and sand. Placing a wooden formwork to make space for the elastic material
- 2 - Putting a new layer of sand with sufficient thickness and uniformly distributed providing to cobblestones a support layer totally flat.
- 3 - Placement of new cobblestones, with surface treated anti-abrasion for added durability. Put sand joint sufficiently thick between cobblestones
- 4 - Once the pavers are fixed, remove the wooden formwork. And finally place the elastic material.

In the case of mold, lichens and mosses, its appearance is due to the damp, so you should act on it and proceed to a thorough cleaning to subsequently apply a treatment or product that prevents new onset of these. In the case of appearance of plants, you must make a cleaned up and repair, using an anti-root treatment.

DIAGRAM OF THE INTERVENTION:

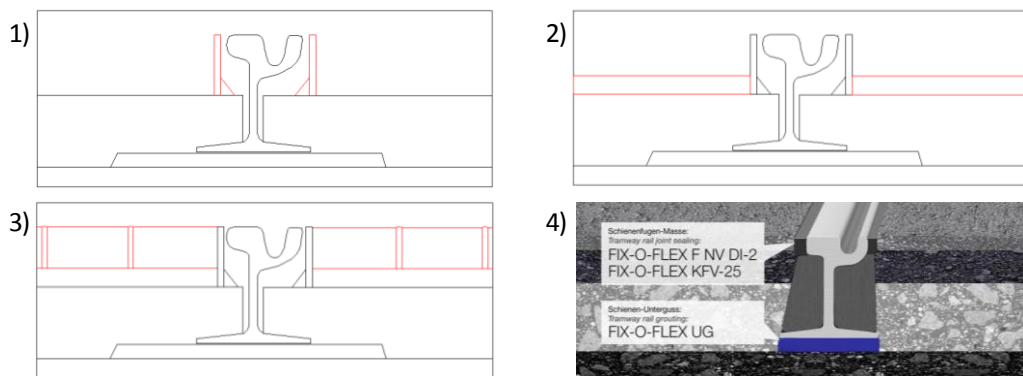

BIBLIOGRAPHY:

- www.librosmaravillosos.com
www.tph-bausysteme.com

DAMAGES

CORRECTIVE/CORRECTING MAINTENANCE

INSPECTION SHEET. DATA COLLECTION

KIND OF LESION:

Defects in the tram tracks and in the top layer of lawn

LOCATION:

Av. Piastow, Szczecin

DATE:

21/02/2013

Nº PICTURES:

2

PICTURES:



DESCRIPTION OF LESION:

As can be seen on the pictures, there are serious damages on the tram tracks

- 1.- Deformations on the rails of the tram tracks. Horizontal displacements of the tracks on both sides
- 2.- Subsidence and elevation of the tram rails due to ground settlement
- 3- Accumulation of dirt and organic residues on the rails of the tram tracks.
- 4.- Deterioration of the grass which forms the top layer of the infrastructure

DANGER OF LESION:

Nothing
 Less
 Medium
 Dangerous
 Very dangerous

POSSIBLE CAUSES:

Overload of all layers that form the infrastructure. The overweight caused by the passage of trams continually can causes movements of topsoil if it isn't maintained.

Lack of maintenance. The waste that are inside of the rails can be avoided with adequate maintenance

Poor solution of the drainage system. It causes accumulation of water and sediment in the lower layers. Following it produces deformations in the ground

Settlement of topsoil due to poor soil compaction

In winter low temperatures cause frost, freeze accumulated water cumulative increases in size causing stresses and ground deformation.

Movement of tram tracks by expansion and contraction of the steel. This cause movement of the topsoil that is in contact with her.

Obstructions in the layer of water filtration. The accumulation of wastes, organic substances or particles may obstruct the evacuation of rain water through the filter layer. It causes water pockets and deformations of the ground

Excess of the humidity, torrential rains, hail or snow can also damage the surface layer.

DIAGRAM:

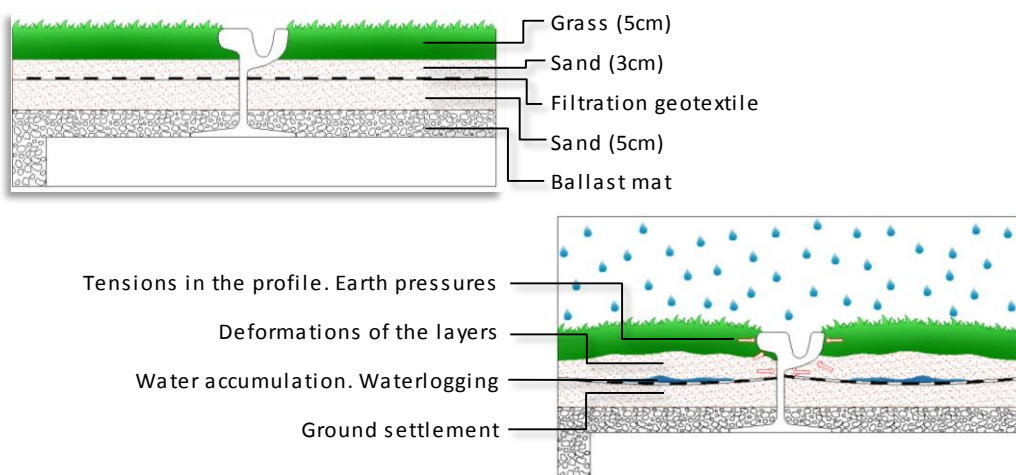

OBSERVATIONS:

DESCRIPTION OF THE POSSIBLE INTERVENTIONS:

Because in most areas are badly damaged rails, is proposed a intervention of all materials. The depth of the layers that are needed to change depend on the condition of these. Following described the process in the case where there has been ground settlement.

1 - Removing the layer of top soil, both sand layers, ballast mat and the filtration geotextile. Removing also the tram rails.

2 - Placement of new profiles that will form the tram tracks and attach them to the sleepers.

3 - Placement of balast mat. If it is possible you can use the old balast mat. Compact this layer with the tamping

4 - Spread the sand layer and after compact this layer. Placement the new filtration geotextile, spread the other sand layer and compact

5 - Finally placement of the new top soil layer

To prevent the possible accumulation of water it can make a small slope in the lower layers.

To prolong the durability is needed a continuous maintenance.

It is very important to make a joint for the separation between steel profile and topsoil. The procedure is described in the pathology tab 1.

DIAGRAM OF THE INTERVENTION:

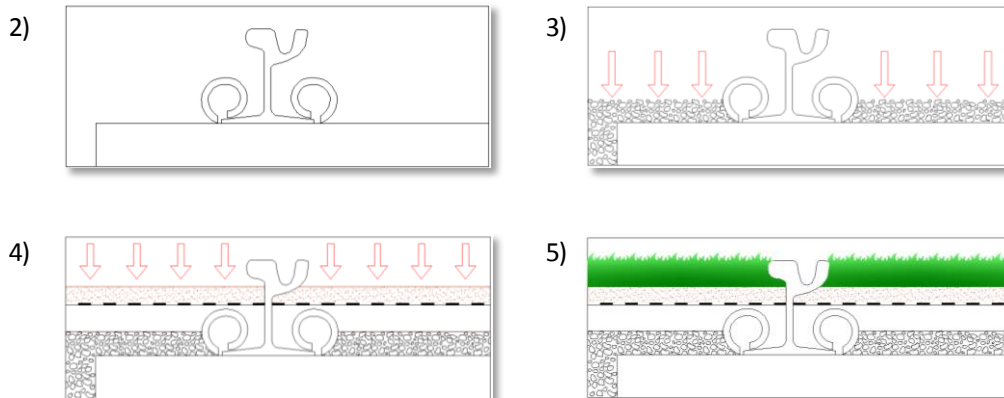

BIBLIOGRAPHY:

<http://szczecin.gazeta.pl/>

DAMAGES

CORRECTIVE/CORRECTING MAINTENANCE

INSPECTION SHEET. DATA COLLECTION

KIND OF LESION:

Defects in the tram tracks

LOCATION:

Av Piastow, Szczecin

DATE:

23/12/2013

Nº PICTURES:

1

PICTURES:



DESCRIPTION OF LESION:

As can be seen on the picture, there are presence of roughness on the tram rails. Small fractures are also seen in the head of the profile which form the rail.

DANGER OF LESION:

Nothing

Less

Medium

Dangerous

Very dangerous

POSSIBLE CAUSES:

Oxidation of steel profiles that forms the tracks of tramlines. It be caused by continued constant exposure to weather conditions.

Lack of maintenance. The waste that are inside of the rails can be avoided with adequate maintenance

The cracks and crevices in the rails may be caused by frozen water. In winter, cold temperatures can freeze water that may have accumulated inside the groove profile. When the water is freeze, it increases in volume and this produces surface tensions that can get to crack profile. The freeze-thaw cycles are the cause of many diseases in materials exposed to the weather in cold areas.

DIAGRAM:



The rainwater accumulates in the hollow of the steel profile.

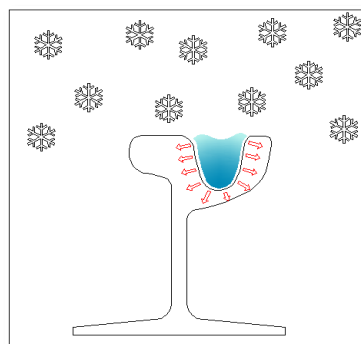

decreases, the water freezes and the volume increase

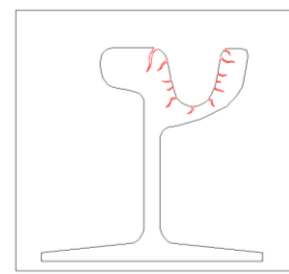

Cracks appear in the metal profile due to the pressure exerted by ice

OBSERVATIONS:

Water increases its volume by 9% when frozen. In areas with frequent frosts is very important to ensure the evacuation of rainwater. If there is stagnant water and las there are sub-zero temperatures the ice can cause dangerous damages.

DESCRIPTION OF THE POSSIBLE INTERVENTIONS:

As previously described, the main problem in this pathology is the accumulation of water inside the gorge profile when the water is frozen and its volume increase can cause cracks in the profile. To prevent the accumulation of water in the profile does need some slight inclinations along the profile or small holes in it. With these two actions will ensure the evacuation of the water.

To prevent the accumulation of water is also very important to execute correctly all elastic joints ensuring its sealing.

It's necessary the construction of drains along the tram tracks for the evacuation of the water.

The problem of oxidation can be treated with chemical products. Applying an anticorrosive on the surface of the steel profile will be protected from oxidation and it can extend the durability.

To prolong the durability of the materials is needed a continuous maintenance.

DIAGRAM OF THE INTERVENTION:

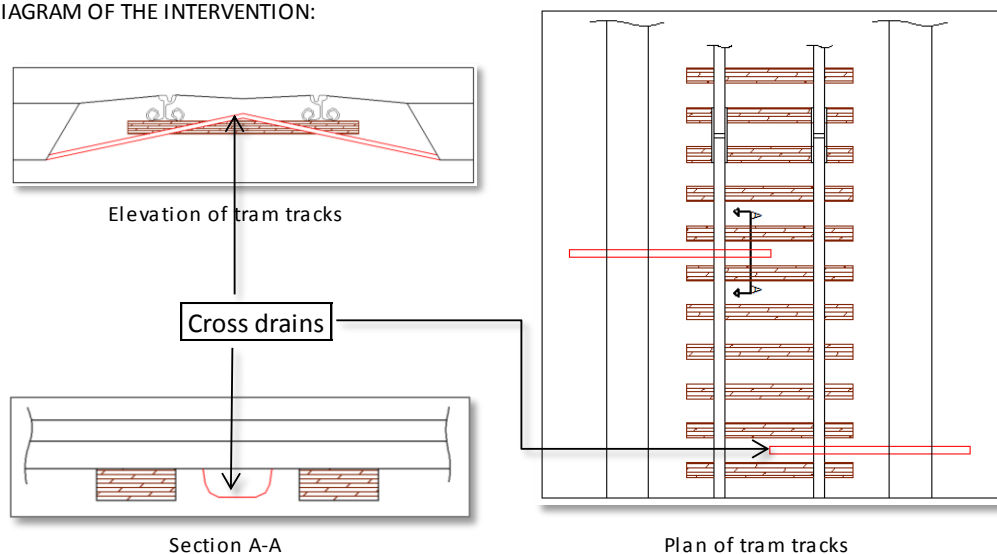

BIBLIOGRAPHY:

www.radioszczecin.pl
www.patologiasconstruccion.net
www.cnrt.gob.ar

DAMAGES

CORRECTIVE/CORRECTING MAINTENANCE

INSPECTION SHEET. DATA COLLECTION

KIND OF LESION:

Defects in the catenary mast

LOCATION:

Szczecin

DATE:

18/06/2014

Nº PICTURES:

2

PICTURES:



DESCRIPTION OF LESION:

As can be seen on the pictures, there are some damages on the catenary mast of the tramways. Is observed a great deterioration in the protective paint that covers the power-pole. There are cracks and crevices on the paint and in some areas, the protect paint also has released. In these areas where the mast is unprotected, it can see the

There is also oxidation around the anchors embedded in the post.

DANGER OF LESION:

Nothing

Less

Medium

Dangerous

Very dangerous

POSIBLE CAUSES:

Dilation of the steel pole by the action of corrosion:

- 1.- Progressive loss of the protective layer of the steel
- 2.- Entry of water and humidity by unprotected areas
- 3 - Corrosion of steel, it make increase its volume
- 4.- Appearance of cracks and crevices in the catenary mast

Thermal expansion of steel

The catenary masts are exposed to the weather 24 hours a day, for this reason, the main cause of its damages are the action of rain water, humidity and snow.

DIAGRAM:

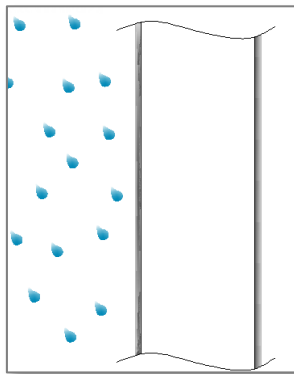

Estado inicial del poste

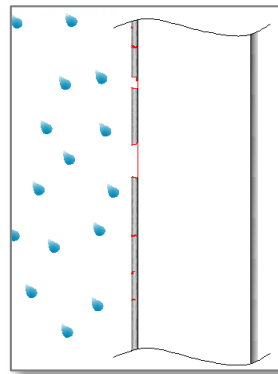

La lluvia provoca el desprendimiento de la pintura dejando al descubierto algunas zonas

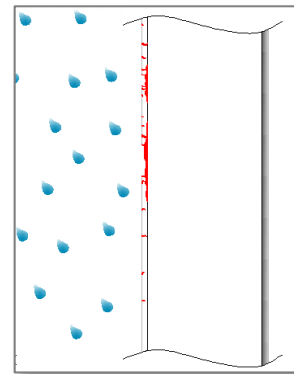

Se produce la oxidación, el metal aumenta de tamaño y provoca más grietas en la pintura

OBSERVATIONS:

DESCRIPTION OF THE POSSIBLE INTERVENTIONS:

Catenary masts are exposed to weather, because of that, they can start developing oxidation over time. When a post has oxidated, you have to repair it by removing the oxide. Repair should be done when a mast begins to show signs of oxide.

Repair process:

- 1.- Scrape out rust that is on the catenary mast with the wire brush. Scraping also remove the paint, dust and dirt of the mast.
 - 2.- Clean the post with a damp cloth to see how much rust remains in the post.
 - 3.- Scrap difficult areas of the oxidation
- Then clean these areas again with a damp cloth. Dampen the cloth with mineral alcohol to remove dust and dirt.
- 5.- Leave the mineral alcohol to dry and then apply a primer layer of anti-oxidant priming on the catenary mast. You can use a spray primer or apply with a brush.-
 - 6.- Apply a new layer of paint to the post. Use brush or spray paint to apply the paint to the post.

DIAGRAM OF THE INTERVENTION:

BIBLIOGRAPHY:

www.ehowenespanol.com
www.patologiasconstruccion.net
www.cnrt.gob.ar

DAMAGES

CORRECTIVE/CORRECTING MAINTENANCE

INSPECTION SHEET. DATA COLLECTION

KIND OF LESION:

Defects in the catenary mast

LOCATION:

, Szczecin

DATE:

18/06/2014

Nº PICTURES:

3

PICTURES:



DESCRIPTION OF LESION:

The protective handrails have serious damage:

- Oxidation in the anchoring elements
- Crack in the base of the handrail post
- Oxidation on the posts
- Paint detachment along the bar
- Roughness and surface deformations
- Presence of plant elements around the base of the handrail post
- Handrail underrun in bad condition on the possibility that may fall

DANGER OF LESION:

Nothing

Less

Medium

Dangerous

Very dangerous

POSSIBLE CAUSES:

Dilation of the steel pole by the action of corrosion:

- 1.- Progressive loss of the protective layer of the steel
- 2.- Entry of water and humidity by unprotected areas
- 3 - Corrosion of steel, it make increase its volume
- 4.- Appearance of cracks and crevices in the bars and anchorages.

Thermal expansion of steel

This handrails are exposed to the weather 24 hours a day, for this reason, the main cause of its damages are the action of rain water, humidity and snow.

Unless the oxidation process is stopped, it will continue until the cracks or breaks expand.

The appearance of organisms in the joints of the pavement is due to water or dampness accumulation in these areas. These microorganisms and plant parasites deteriorate the handrail underrun.

DESCRIPTION OF THE POSSIBLE INTERVENTIONS:

Depending on the oxidation state of each pole, it can be possible to repair or replace each one.

If the damage is only in the paint or is slightly rusted, the process to follow is the same as the indicated on the pathology sheet number 2.

If, on the other hand, the pole is broken or the rust is excessive, the pole must be replaced.

If the problem is in the pole attachment, the pole must be retired, the floor must be drilled or braked with a mechanical driller or hammer, relocate the pole and pour concrete.

In the case of mold, lichens and mosses, its appearance is due to the damp, so you should act on it and proceed to a thorough cleaning to subsequently apply a treatment or product that prevents new onset of these. In the case of appearance of plants, you must make a cleaned up and repair, using an anti-root treatment.

BIBLIOGRAPHY:

CHAPTER 7:
SAFETY AND HEALTH

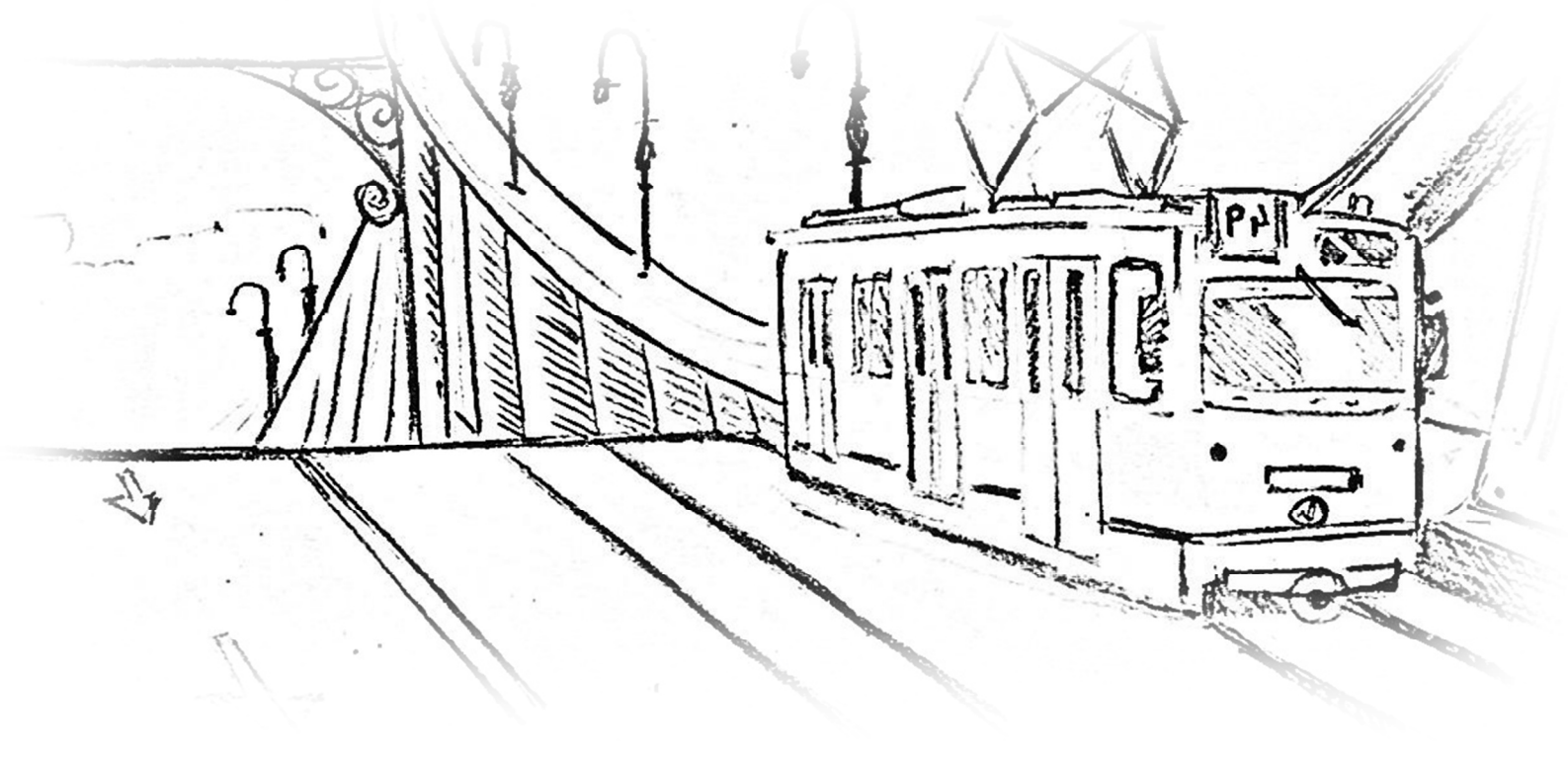

This study of health and safety includes all actions to prevent risks of occupational accidents and illnesses, as well as derivatives of the repair, upkeep and maintenance, hygiene facilities and welfare of workers.

For this study, only the works of Szczecin will be considered, since at present there isn't renovation, expansion or new developments respect to tram net in Valencia.

7.1 INPUT DATA FOR THE DEVELOPMENT OF THE STUDY

7.1.1 Siting

The works to which assigned the following study are the works located on Piastów avenue and Potulicka street both of the city of Szczecin.

7.1.2 Description of streets

- *Piastów Avenue*: is one of the streets most travelled of the city. In this area, most of the buildings are residential buildings with ground floor commercial premises. The predominant use in this street is residential and educational.
- *Potulicka Street*: are included in the old part of Szczecin, near to the river. This zone is mainly residential use but you can also find some office buildings.

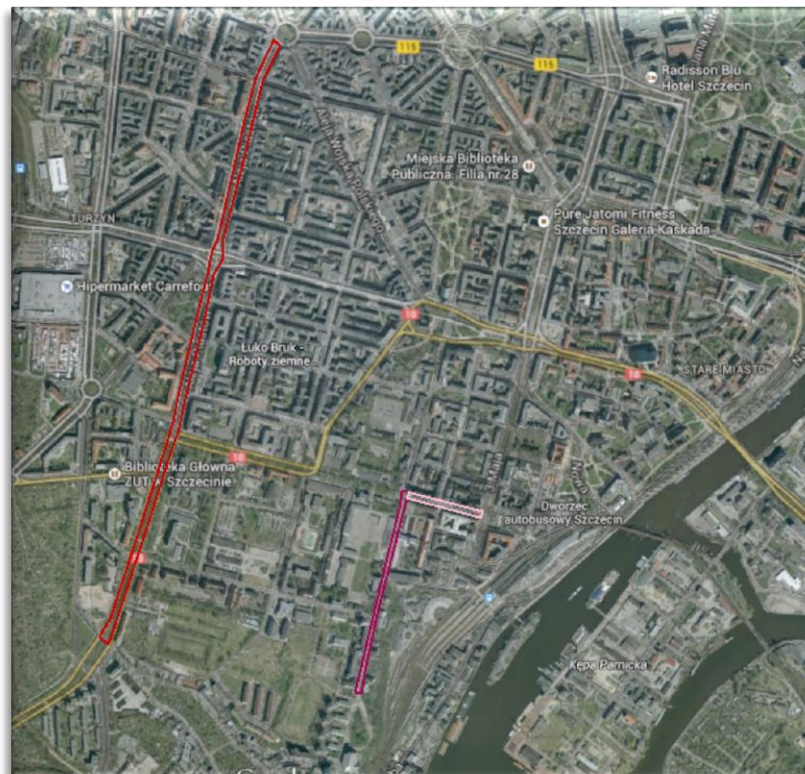

7.1.3 Denomination

Both works are about reconstruction of the infrastructure of the tram net.

7.1.4 The nearest medical center

In the case of accident, both workers at the Piastów Avenue and Potulicka Street, will move to the same hospital (Samodzielny Publiczny Szpital Kliniczny nr 2 w Pomorskiego Uniwersytetu Medycznego Szczecinie). The route shown on the map below:

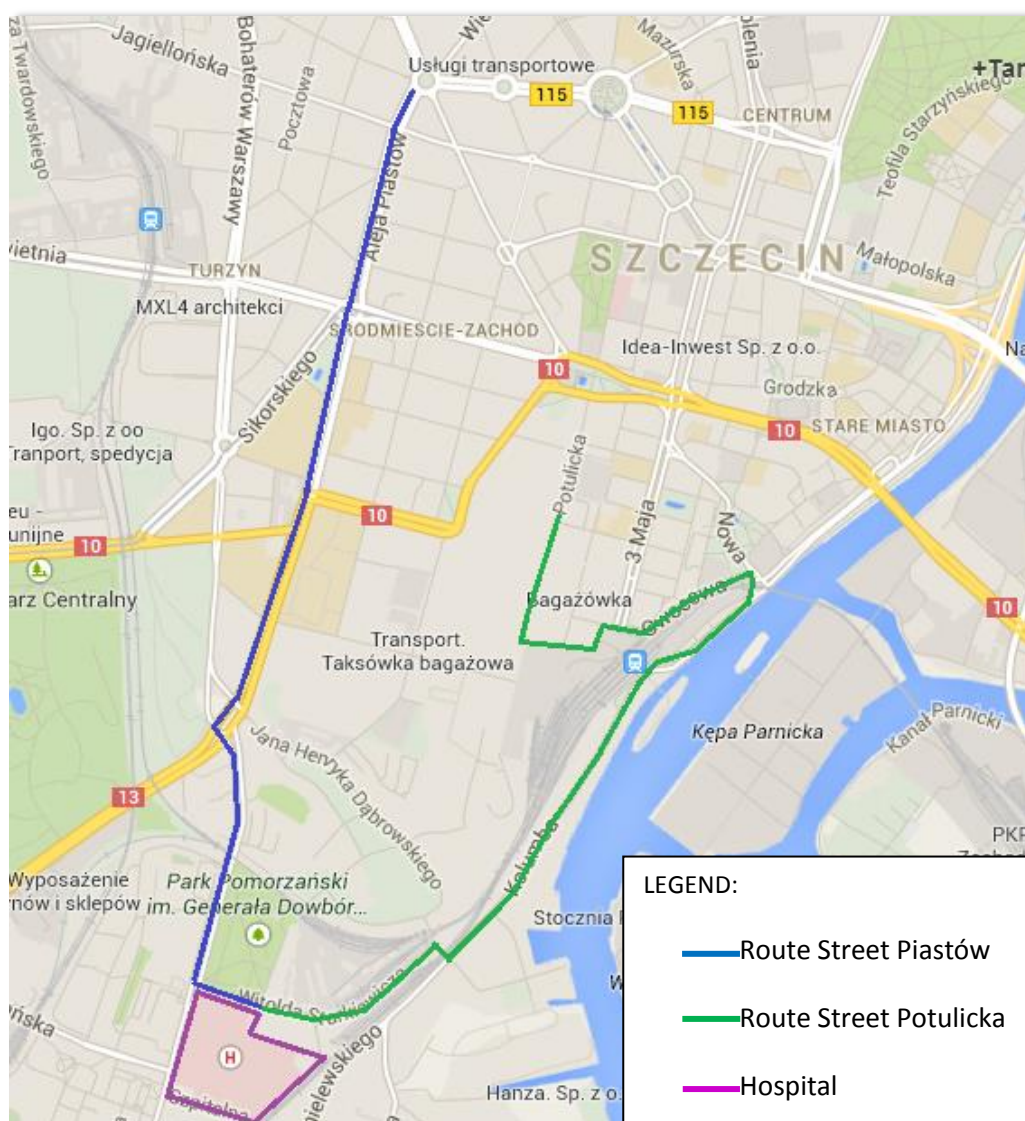

7.1.5 Existing installations

The works are in urban areas, so they have access to all supplies on site: road access, electricity supply, water supply, etc..

7.1.6 Movement of people unrelated to the works

The works are located in areas with pedestrian traffic and road as well as access roads to it, so you should take the following measures:

Outsider's access to it is strictly prohibited.

As prevention of potential risks that it may cause on these subjects, it will comply with the general rules described in a later section.

7.1.7 Layers characteristics

Although these are two tram reconstruction, the materials used and the number of layers varies. All details and layers for each of the works are specified in the "chapter 5: study and constructive and equipment analysis" in this study.

7.1.8 Provisional facilities

The Provisional water supply facilities, electricity and drainage will be connected to the public networks of the city. Placement of the houses of offices, canteen and dressing is expected and a perimeter fence in areas where it is necessary.

7.1.9 Work equipment provided

- Machinery: Wheel Loader, dump truck, breaker hammer, truck mixer, backhoe, welding machine, truck mounted crane, welding machine.
- Auxiliary products: total station.
- Hand tools in general.

7.2 SAFETY INSTRUCTIONS FOR ACCESS AND MOVEMENT OF PEOPLE

Independent access shall be provided to personal and construction machinery. Next to each entry will be placed indicative signs of Compulsory use of helmets and Trespassing anyone attached to the work.

The houses should be placed near the entrances and if it is not possible close of them. Some possible solutions are shown on the next map.

- a) FENCES: should be a fenced in areas of the works that require or permit, before the start of the work. The fencing must be 2.00 meters in height, must be resistant to climate action, shock, etc.

- b) SIGNALING must have:
 - GRAPHIC SIGNS OF PROHIBITION:
 - Prohibited to park in areas close to the works
 - No entry for pedestrian in areas where vehicles circulate
 - Trespassing to any person outside the work

 - GRAPHIC SIGNS OF OBLIGATION:
 - Obligation of helmet use in the enclosure
 - Eye protection required (if applicable)
 - Obligatory use of safety boots
 - Obligatory Protection gloves
 - Obligatory Detour for pedestrians

 - GRAPHIC WARNING SIGNS
 - Danger in general
 - Loads suspended
 - Electric risk

 - LUMINC SIGNS

The entire route of the work, as well as interim steps for pedestrians will be marked with light when it is dark for correct display of the works.

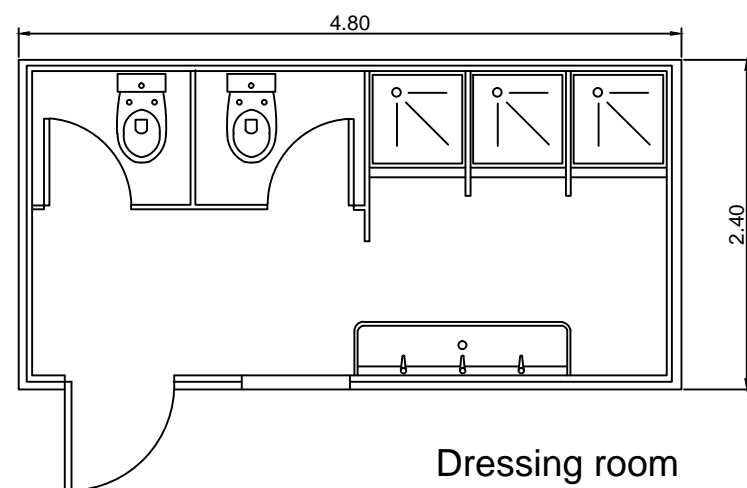
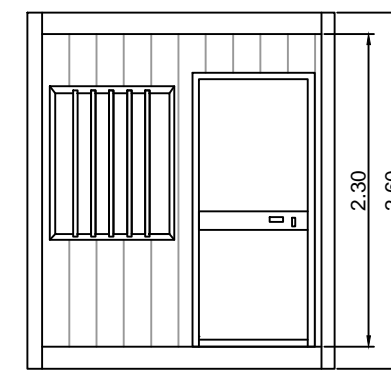
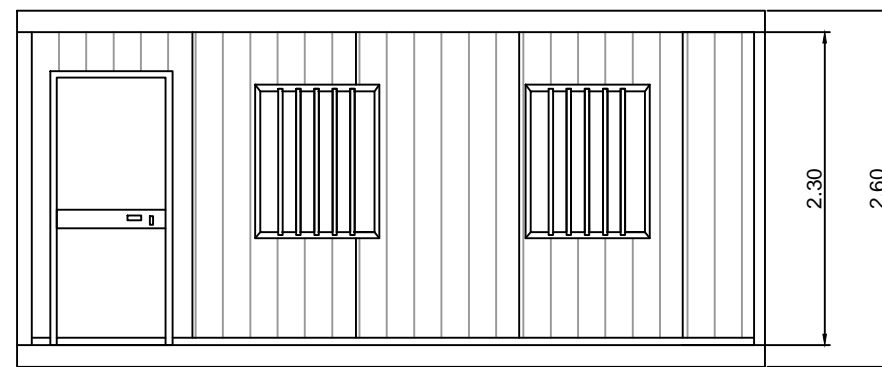
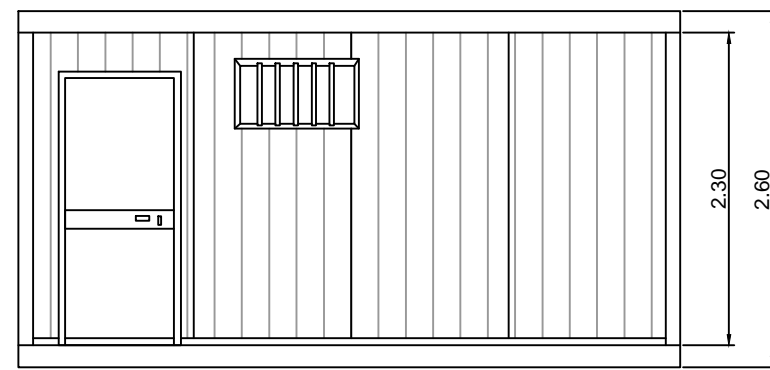
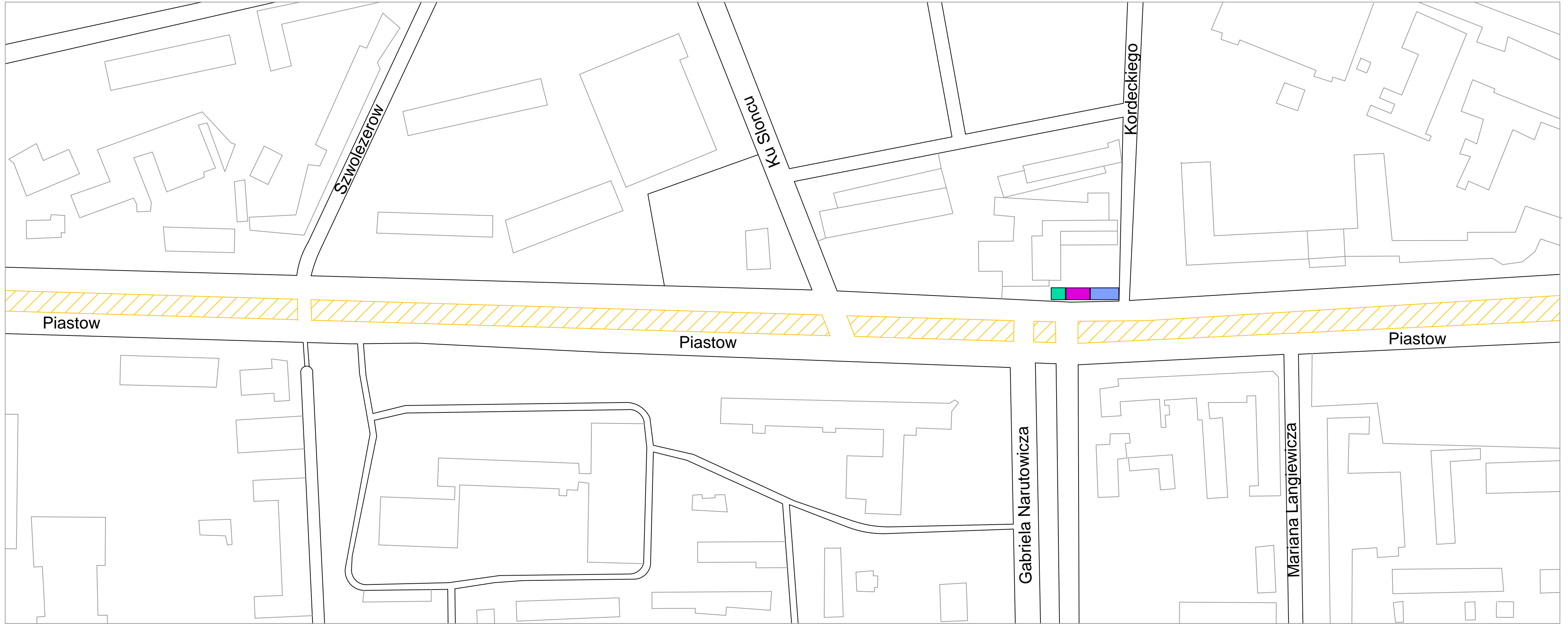

Dressing room

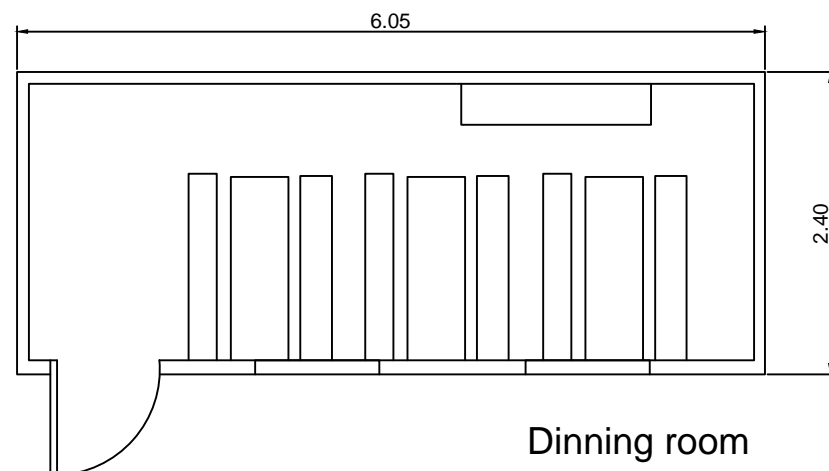

Dinning room

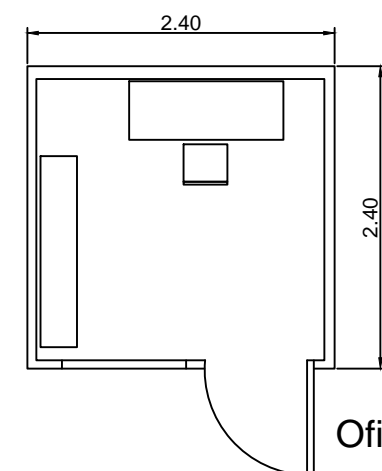

Office room

LEGEND

- Work zone
- Dinning room
- Dressing room
- Ofice room

Final Project: comparative study between Szczecin and Valencia of the construction of the tramway infrastructure		
Title of plane: Situation of site huts in Piastów Avenue		
Authors: PÉREZ TOMÁS, Tania TAMARIT LATRE, Irene	Course: 2013 - 2014	
Scale:	Situation: Szczecin	Nº of plane: 17

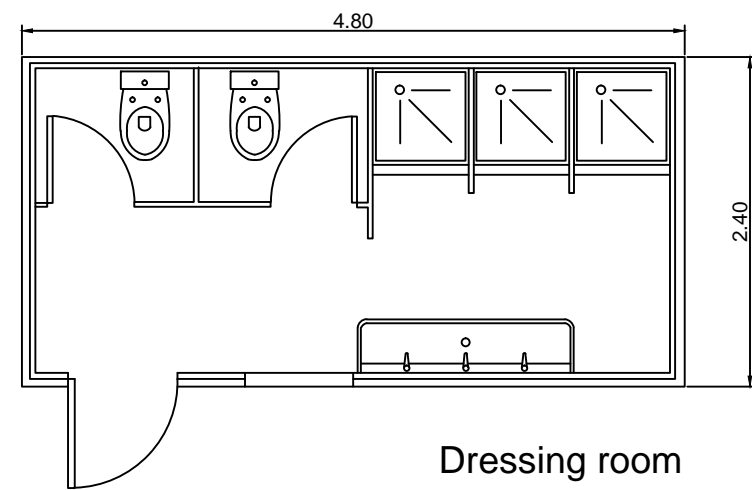
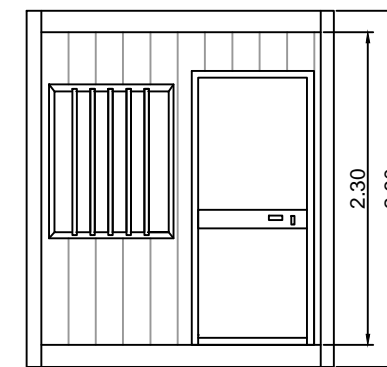
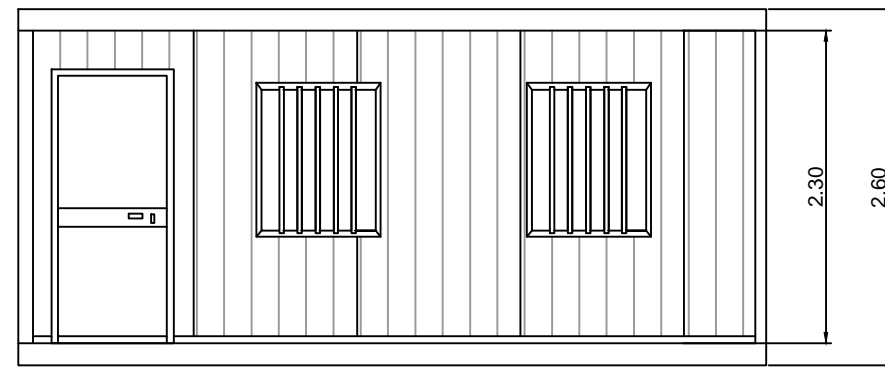
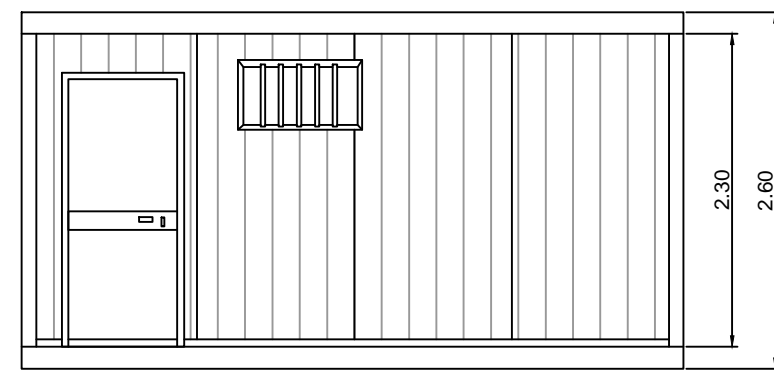
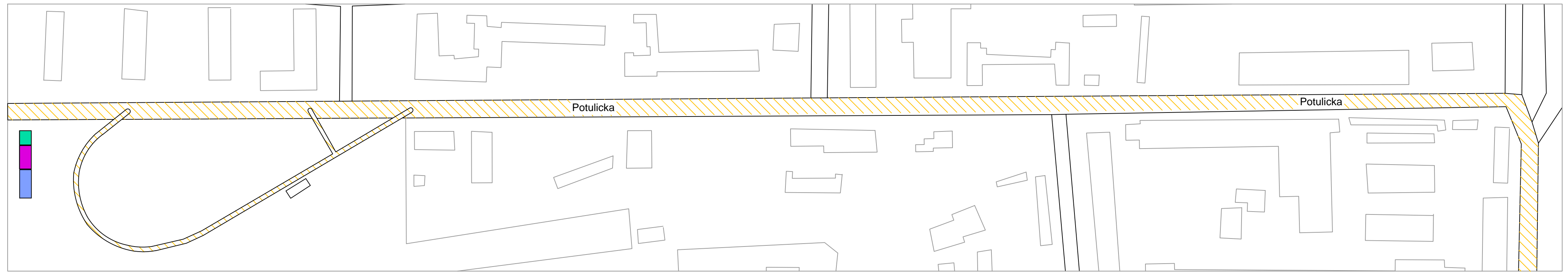

Dressing room

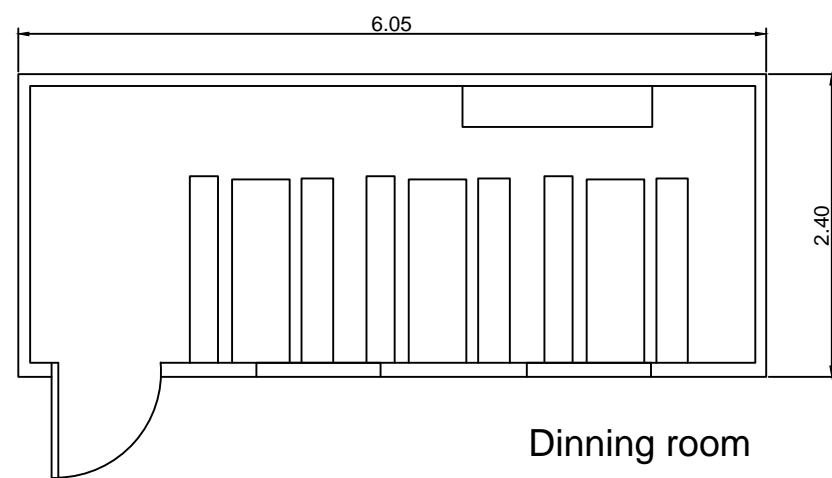



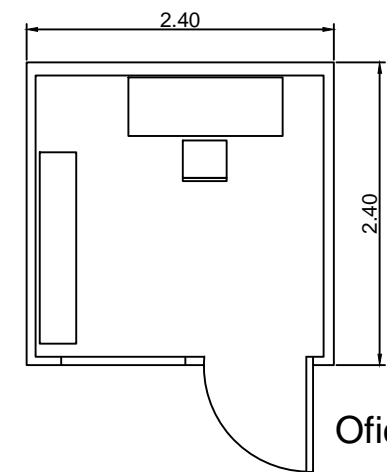

Dinning room



Ofice room

LEGEND

-  Work zone
-  Dinning room
-  Dressing room
-  Ofice room

Final Project: comparative study between Szczecin and Valencia of the construction of the tramway infrastructure		
Title of plane: Situation of site huts in Potulicka Street		
Authors: PÉREZ TOMÁS, Tania TAMARIT LATRE, Irene	Course: 2013 - 2014	
Scale:	Situation: Szczecin	Nº of plane: 18

7.3 HYGIENIC SERVICES, FIRST AID, DINING ROOM AND OTHER VENUES OF SERVICE AND USE

In the office first aid kit will be installed. The kit will have the basic material for primary health care and it must contain: oxygenated water, 96 ° alcohol, iodine, ammonia, cotton wool, sterile gauze, bandages, tape, antispasmodics, rubber bags for water and ice, sterile gloves, syringes, kettle and clinical thermometer.

Monthly content will be reviewed and the material used or expired immediately will be restored.

There will be a multipurpose dry powder extinguisher of 13A efficacy in office work.

There will be changing rooms, toilets, supplemented by necessary auxiliary elements: towel racks, etc.

The changing rooms will be equipped with seats and individual lockers for clothes and footwear. It must be available hot and cold water in showers and sinks.

Dining rooms will be equipped with tables and chairs in sufficient numbers. It also has a microwave, sink with running water and adequate facilities for the number of existing operators at work. There will also be a container for garbage collection.

To account for the space needed by the number of workers on site, will be done according to these relationships:

- CHANCHING ROOM
 - 2 m² /worker
 - minimum height of 2.30 metres

- TOILETS
 - 1 for 10 workers
 - 1 Sink
 - 1 Shower
 - 1 Mirror
 - 1 Toilet

- TECHNICAL OFFICE

Note:

All temporary facilities shall have natural and artificial lighting and a ventilation system. The walls and floor are smooth and impervious. The situation of these depends on: the conditions of the works or the nearest point where network can be performed.

They must also have a sign with all phones of emergency services in a visible and locatable area.

In the case that any special clothing of a worker may be contaminated with flammable or corrosive products, or it may involve some risk, a separate shower and containers will be available where put the dirty clothes to treat it later.



House work. Source: www.cladoo.es

7.4 MEASURES IN CASE OF EMERGENCY AND SAFETY INSTRUCTIONS

- Training and information on safety and health:

The builder is responsible for training (theoretical and practical) and information the workers in safety and health. He should give them the risk assessment for each job.

The constructor should also be responsible for providing personal protective equipment and to teach them proper use and maintenance, informing them of the preventive measures taken for the risks that they are exposed.

It is necessary that at least one of the workers have basic notions of first aid.

- Emergency measures

In general a protocol and services are to be considered in an emergency, including:

1. Provision of a first aid kit appropriately equipped, located in the area of attention of the injured.
2. Location of emergency phone numbers in a conspicuous place of the work (the nearest hospital, firefighters, police, etc.)
3. Zones access to the works should be kept clean and tidy to ensure a quick step and safe in case of emergency.
4. Must be placed appropriate signs (standardized)

- Treatment of dangerous materials

Flammable, corrosive, toxic and irritant materials will be treated by specialist workers in ventilated areas to avoid possible contamination of other workers

Designated workers for manipulation shall be dressed in the corresponding epi's.

The excess material will be caught in its container and it will remain closed under suitable conditions; Empty containers should also be collected and processed by a company specializing in waste management.

The excess waste and empty containers are stored in a separate place from the rest.

- Clean and tidy

The works must run in a perfect state of order and cleanliness to facilitate good organization and effectiveness of the activities to realize.

Employers must collect the surplus materials or they must accumulate the residues directly in the containers provided for this purpose.

Deben de realizarse limpiezas periódicas, preferiblemente al terminar fase de las obras.

Periodic cleaning should be performed, preferably after each phase of work.

When using hand tools or similar connected to the electricity grid is recommended these tools would be disconnect immediately to the network after completing the tasks or not being used, to avoid problems with the wiring or self-powered tool.

Cleaning of areas for dining rooms, changing rooms, toilets, etc., should be performed every day, preferably outside of working hours. Once a week disinfection will be also performed.

- Material Handling

Material handling is always made by the corresponding protections, both collective and individual.

It must always be superior mechanical to manual handling. If materials are handled manually it would take more than one worker.

Workers must apply everything learned in preventive training on manual handling of loads and specific training for the machines or tools to use.

- Location of jobs and work areas

The jobs must be conditioning in as much as possible, so that workers:

1. They are protected against falling objects or entrapment.
2. They can leave quickly their jobs in case of danger or they can receive help immediately.
3. They can't slip or fall.

Performance of work by operators who don't have sufficient preparation and training, they will not be allowed when they can cause risks to their health or safety or to the other workers.

All work will be provided with the means of protection, whether collective or individual.

7.5 PREVENTIVE MEASURES, INDIVIDUAL AND COLLECTIVE PROTECTION

Risk: Direct electrical contacts of the machinery and operators with tension elements	
Causes	The realization of the lifting of materials by operators in the area of electrical danger.
Preventive measures	Operators who perform activities of lifting must be trained and informed about the activity
Collective protection	
Individual protection	Safety helmet, safety shoes, insulating gloves

Risk: Falls on the same level	
Causes	Performing work at night with poor lighting
Preventive measures	The night work will be performed with sufficient lighting
Collective protection	Illumination of works
Individual protection	Safety helmet, safety shoes

Causes	Transit workers on the tracks
Preventive measures	Do not walk on the rails
Collective protection	
Individual protection	Safety helmet, safety shoes

Causes	Collision with a rail
Preventive measures	The obstacles or areas with certain risks must be marked
Collective protection	
Individual protection	Safety helmet, safety shoes

Causes	Slips from the existence of wetlands to walk on the surface of the rail
Preventive measures	Operators should be informed and educated about the risks associated with circulation through surfaces of railways and adjacent areas
Collective protection	
Individual protection	Safety helmet, safety shoes

Risk: Projections of particles	
Causes	Using tools for cutting rail without proper personal protection
Preventive measures	Operators must use the appropriate protections.
Collective protection	
Individual protection	Safety helmet, safety shoes, safety goggles against particles and projections



Risk: Falls to different level	
Causes	Operations of climb or descent to posts, review work of signs, traffic lights, etc.
Preventive measures	Work at height will be performed using specific work equipment or from work platforms equipped with protection systems
Collective protection	Railings normalized on work platforms
Individual protection	Safety helmet, safety shoes, fall arrest harness

Causes	Work being located on platform of material transporting trucks or on the ascent and down of them
Preventive measures	Collective protection shall be placed For ascent and descent of machines should be performed in front of them using the steps, avoiding jumping from the cab
Collective protection	Protection railings when operators are working on trucks
Individual protection	Safety helmet, safety shoes



Risk: Overturning of machinery	
Causes	Overload of machinery, improper load distribution, etc.
Preventive measures	You must select the load lifting equipment for each situation depending on the type and weight of the load to lift, support and stabilization elements
Collective protection	
Individual protection	Safety helmet, safety shoes

Causes	Location inadequate or insufficient strength of the support machinery.
Preventive measures	You must select the load lifting equipment for each situation depending on the type and weight of the load to lift, support and stabilization elements
Collective protection	
Individual protection	Safety helmet, safety shoes

Risk: Exposure to vibrations hand, arm or complete body	
Causes	Using vibrating hand tools
Preventive measures	Perform rotations of operators in the implementation of activities in which cause vibrations.
Collective protection	
Individual protection	Safety shoes and safety gloves

Risk: Entrapments, crushing, knocks or cuts caused by materials or equipment

Causes	Uncontrolled spins of suspended loads
Preventive measures	Work on the use of work equipment for lifting loads is required, must be achieved with operators strictly necessary.
Collective protection	
Individual protection	Safety helmet, safety shoes

Causes	Incorrect manipulation of hand tools
Preventive measures	Hand tools should be used according to the manufacturer's instructions
Collective protection	
Individual protection	Safety helmet, safety shoes and safety gloves

Causes	Overturning of materials by improper storing
Preventive measures	Avoid storing of material on the tram rails and it should preferably use the lateral edge zones
Collective protection	
Individual protection	Safety helmet, safety shoes

Risk: Overexertion	
Causes	Incorrect manual handling of loads or requiring high physical exertion continuously.
Preventive measures	<p>When handling heavy objects, you must use auxiliary load handling equipment or the weight is distributed among various operators.</p> <p>We recommend conducting exercises of muscle warming prior to start of work</p> <p>Perform rotations of operators in the realization of activities that require more effort.</p>
Collective protection	
Individual protection	Safety helmet, safety shoes and safety gloves

Risk: Fire or explosion	
Causes	Incorrect manipulation of combustible or flammable products
Preventive measures	Dangerous fuels and products must be clearly identified, labelled and in proper containers for use
Collective protection	Extinguishers
Individual protection	Safety helmet, safety shoes and safety gloves

Causes	Welding of rails
Preventive measures	It must have adequate fire extinguishers in the work area
Collective protection	Extinguishers
Individual protection	Safety helmet, safety shoes and safety gloves

Risk: Exposure to aerosols and gases by inhalation	
Causes	Presence of suspended dust particles of ballast handling.
Preventive measures	Water should be applied prior to the ballast debugging operations or manipulation
Collective protection	
Individual protection	Safety shoes, respiratory protection equipment suitable for the chemical agent

Causes	Existence of combustion gases from of machinery in poorly ventilated areas (such as tunnels)
Preventive measures	Provide air vents to improve air quality in the work area
Collective protection	
Individual protection	Safety shoes, respiratory protection equipment suitable for the chemical agent



Risk: Exposure to noise	
Causes	General noise from machinery and railway vehicles
Preventive measures	Continuous operator exposure to the noise should be avoided as much as possible
Collective protection	
Individual protection	Safety helmet, safety shoes, suitable hearing protection from noise

Risk: Running over by circulations and railway equipment	
Causes	Existence of railway traffic in their own work or adjoining roads.
Preventive measures	There will always be an operator watching the tracks, if there is a presence of a tram, it is notified to other operators, who will be removed to the outside of the line
Collective protection	Whistle for reporting to other operators to withdraw the tracks
Individual protection	Safety helmet, safety shoes

7.6 COMPARISON STUDY WITH REAL WORKS

Then a comparison between the earlier study and reconstruction of tram net in Szczecin, in the street Potulicka and Avenue Piastów is performed.

It shows the correct and wrong actions and how to solve it the latter:

- Site huts





As for the site huts that are described previously, we didn't observe the existence of them in works. So their installation is very important, as they are places of rest or for the health of workers as well as for saving documents of works, such as the project execution plans, etc. So if there is any doubt during the execution of the work it can be quickly remedied by reviewing the documents.

Only we have seen the presence of portable toilets, but they are not sufficient, so the installing of prefabricated sheds is obligatory. The positioning may be performed according to the foregoing plane.



Portable toilets. Source: Author

- Fenced before the start of work

Piastow Avenue	
<p>It is not necessary that the fence have 2 meters high if we want to achieve separate two tracks linked by a cross. To separate it just we have to put plastic drums filled of water, as the image shown. This is done to isolate the work of the traffic.</p> <p style="text-align: right;">  <i>Correct</i> </p>	
<p>However if you want separate areas where there is a crosswalk, so if you need to put a fence 2 meter high as a means of separation. This should be well anchored to the ground or have a good base to prevent overturning.</p> <p style="text-align: right;">  <i>Correct</i> </p>	

Potulicka Street

For Potulicka street there are areas where you can see a good hedge for the delimitation of the work, provided all parameters (2 meters, good base to prevent overturning, etc.), an example of that good placement of the fencing is shown in the image.

✓ *Correct*



However there are areas that the placement or selection of that fencing is wrong. Since as shown in the image, where the fencing does not perform its function as more elements are missing. In addition to separate pedestrian zone we should use a more appropriate type of protection (as shown the image of the following section).

✗ *Incorrect*





In the second image, we see that the works have already started but there is no fence separating the pedestrian area of the works. So they should have installed a fence before the start of works.



✗ *Incorrect*



- Diversion of pedestrians

Piastow Avenue	
<p>On the avenue any incorrect fenced pedestrian crossing is observed, as they have as a minimum 1.10 meter high and they are composed of a lowest batten, an intermediate and an upper, as shown in the picture.</p> <p style="text-align: center;"> ✓ <i>Correct</i> </p>	
Potulicka Street	
<p>In the work of Potulicka there are areas where the fencing for pedestrian crossing is of very good quality, it does not allow the passing through it.</p> <p>In the picture we can see that has good stability and good resistance. It is also well placed.</p> <p style="text-align: center;"> ✓ <i>Correct</i> </p>	
<p>However there are areas that the fencing for the separation of pedestrian crossing with the work is very bad, because it is not made of one lowest batten, one intermediate and one superior.</p> <p>As shown in the image it have little resistance, and its main function (prevent entry of outsiders to work) does not do it because you can easily pass under.</p> <p style="text-align: center;"> ✗ <i>Incorrect</i> </p>	

- Signage

Piastow Avenue	
<p>The works of the Piastów avenue to be among the circulation of cars is necessary to put light or similar markings.</p> <p>As shown in the image there are signals with the lighting of cars are clearly visible. Serve to mark the work and don't cause accidents at night or day.</p> <p style="text-align: right;">✓ <i>Correct</i></p>	
<p>As the picture shows there are also warning signs, such as rail deviation or signs warning of the works.</p> <p>They are arranged along the avenue to avoid accidents.</p> <p style="text-align: right;">✓ <i>Correct</i></p>	
<p>When there is any deviation crosswalk, there should be a warning signal for that deviation.</p> <p>Nowhere there is this signal so it can be confusing to pedestrians.</p> <p style="text-align: right;">✗ <i>Incorrect</i></p>	



Potulicka Street

Works on Potulicka invade the movement of vehicles so the streets are closed.

There are no entry signs, no parking at the entrance to the machinery in the work, etc.

✓ *Correct*



Should not only take into account the placement of the signs, but they also should check it time to time and check the compliance of their function.

As shown in the image, there are signs on the soil or neglected signs, therefore they don't comply with function of informing.

✗ *Incorrect*



In Piastów Avenue and Potulicka Street there aren't existences of signs indicating that any person who enters in the work must wear a protective helmet and safety boots. An example of such signals is shown in the image. In both works the signs must be mounted on all existing entries in the works.



- Clean and tidy

Piastow Avenue

The works of the Piastów Avenue are characterized by order and cleanliness of them.

Whenever we went to visit the works, they have been in perfect condition, which is an advantage for workers in terms of safety.

An example of this is the following photos taken of works.

✓ *Correct*

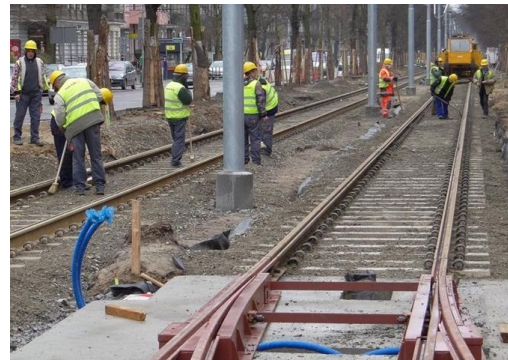

Potulicka Street

Potulicka works also exist areas where order and cleanliness are very good.

This is done to prevent workers falling by tripping over with the materials and ensure they do not hurt themselves.

✓ *Correct*



Although these works are not always clean and tidy, there are areas where the disorder can cause damage to the workers.

Therefore, the work must be kept clean and tidy to predict risks on workers (such as the works of the Piastów Avenue).

✘ *Incorrect*



- Stockpiling

Piastow Avenue

Stockpiles must be correct to prevent tipping and falling materials on any operator causing serious damage.

These stockpiling should performed depending on the type, weight and shape of material. A good example of a collection is shown in the image.

✔ *Correct*



Potulicka Street

In Potulicka Street a good stockpiling are also performed.

Another good example of a good collection is shown in the image of the works.

✓ *Correct*



- Collective protections

Piastow Avenue

The use of collective protection is very important, especially in overhead work.

As shown in the picture, the machinery or auxiliary facility to work at height must be equipped by railings.

✓ *Correct*



The difference in height or hollows must be marked or protected by collective protection.

In the picture must be seen an unevenness, however it is small and has little depth, it must be marked.

✗ *Incorrect*



Potulicka Street

As commented in the previous image, if there is a hole it must be marked or protected.

As shown in the picture, the hole is protected by rails in one side, although these are few and poorly placed, but on the other side there is no existence of such protection.

✗ *Incorrect*



- Individual protection

Piastow Avenue

All operators in the area of the works must wear a protective helmet and safety boots, both homologated.

As shown in the image, all operators of Piastów works are equipped with corresponding protection.

✓ *Correct*

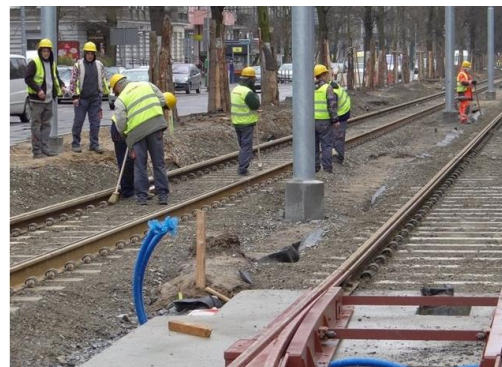

Operators must not only wear helmets and safety boots, but rather if they are doing an activity that causes a risk to another part of the body, they must be placed the corresponding protection.

As shown in the image, the operator responsible for carrying out the welds is equipped with special gloves.

✓ *Correct*



Potulicka Street

As shown in the images some operators do not wear a helmet.

There are also operators that instead of wearing a helmet wear caps. This must be taken into account that the helmet serves to protect operators from blows to the head.

A cap does not protect the blows.

Once they enter into the work zone ALL operators must wear helmets.

X *Incorrect*



The work visits carried out shows that in the works of Piastów are more adapted in terms of safety and health. The works are more clean and tidy, and operators are more aware on Safety and Health than works in Potulicka Street.

CHAPTER 8: CONCLUSIONS

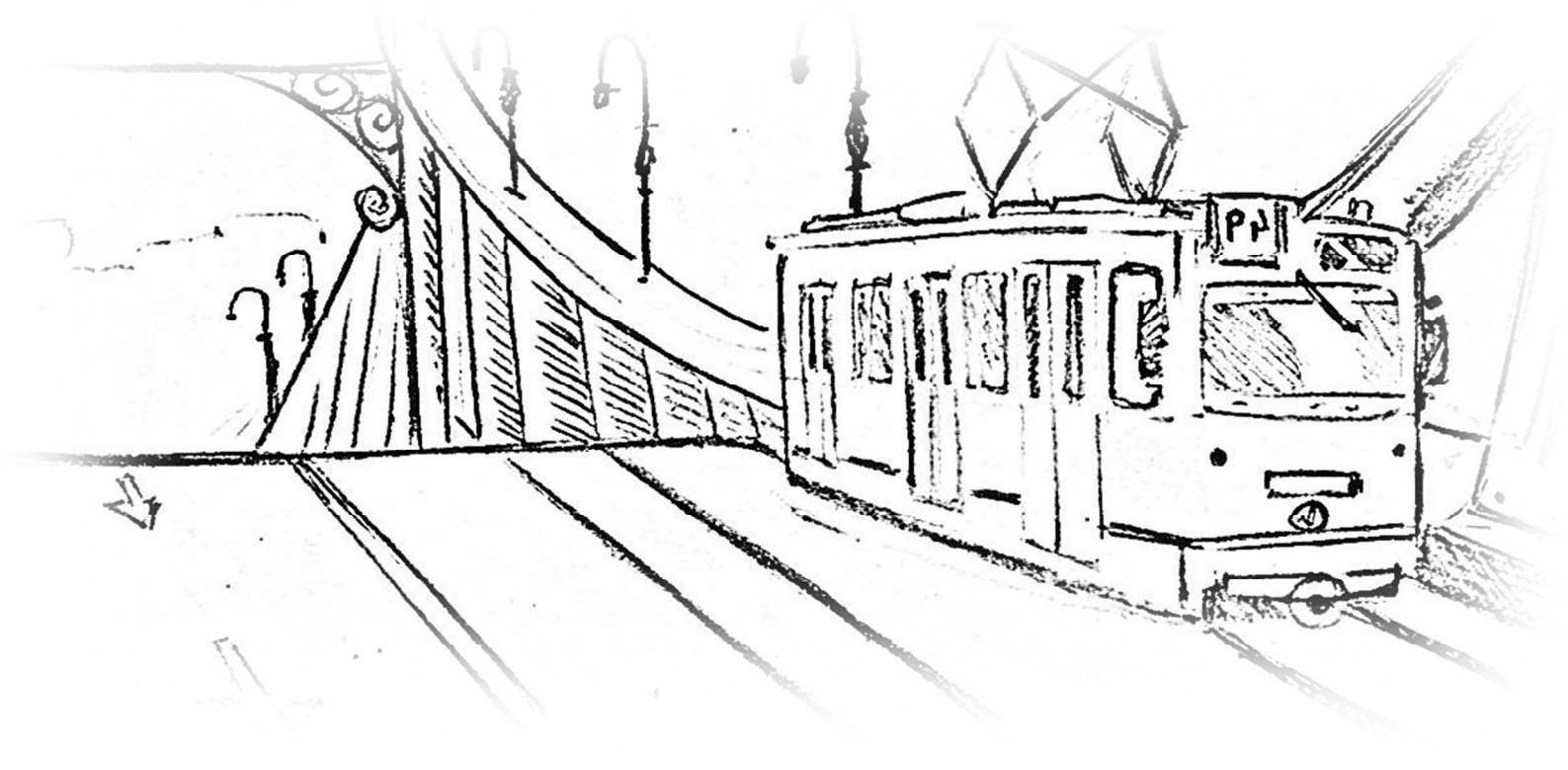

8.1 CRITICAL EVALUATION

Over the last few years, tram ways have experienced a veritable resurgence in European cities this is because the tram ways represents a new surface transport which are reliable, fast, accessible, comfortable, safe and environmental friendly.

In the comparative study between two European cities, Valencia (Spain) and Szczecin (Poland), it can be seen that the increase in the use of trams is true, because the infrastructure is improved and new lines of connection are created inside cities.

It must be taken into account that it isn't only a vision from the point of view of engineering because it is also directly or indirectly connected with architecture, this is reflected in the tram stops, which in some cases are a real masterpieces of art.

From the urban point of view we have been shown that although Valencia is a city with a larger population than Szczecin, it has less tram lines operating in the city. In this way the city of Szczecin has greater coverage and connects almost every places of the city with the tram net and the areas that are not connect it will also be thanks to the construction of the "Fast Tram" in a future.

Although tram lines (or meter) in Valencia are scarce in the city center, these lines connect the center with nearby towns, so a single line can runs through many more kilometres than in the polish city.

In many aspects as the form of labour, equipment and used materials, both cities have many things in common, because we have been verified to work visits, both the machinery and the materials are the same or similar in both cities.

8.2 PERSONAL EVALUATION

After the study, we concluded that the tram in Szczecin city plays a more important role than in Valencia city.

This is based not only on the existence of the largest number of tram tracks but also in the facilities offered by the government to citizens for using this means of public transport; prices are much lower and there are more significant discounts.

In addition, efforts had been made by Szczecin to build new tram networks is higher than in Valencia. In both cities there are plans to extend the tram network but in the Spanish city these projects are stalled for a long time, while in Szczecin there is more interest in developing this transport, one proof of this is the rehabilitation works that we have studied.

During visits to these works, various aspects have attracted our attention. The most significant are the daily working hours in Szczecin; the number of hours of a working day is higher than in Valencia, probably this is due to the importance of the work and the inconvenience by both the traffic and the pedestrian.

Another important aspect that we have observed is the absence of work cabins; this element is required at Valencia works. These works had only mobile toilets.

We noticed a big difference in the level of order and cleanliness of the works. We can say that the works of the Piastów Avenue are a role model, while in the Potulicka street the disorder, dirt, low maintenance of fences, lack of signs, etc, are very present.

We think Valencia should follow the steps being Szczecin regarding improvements tram networks, as we believe it is a medium that offers many advantages. Instead Szczecin have to improve the working conditions of workers in the works.

With this study we have learned that architecture is present in almost all areas of engineering and despite the distance and cultural differences in the way to build there are not many differences in both cities.

CHAPTER 9: BIBLIOGRAPHY

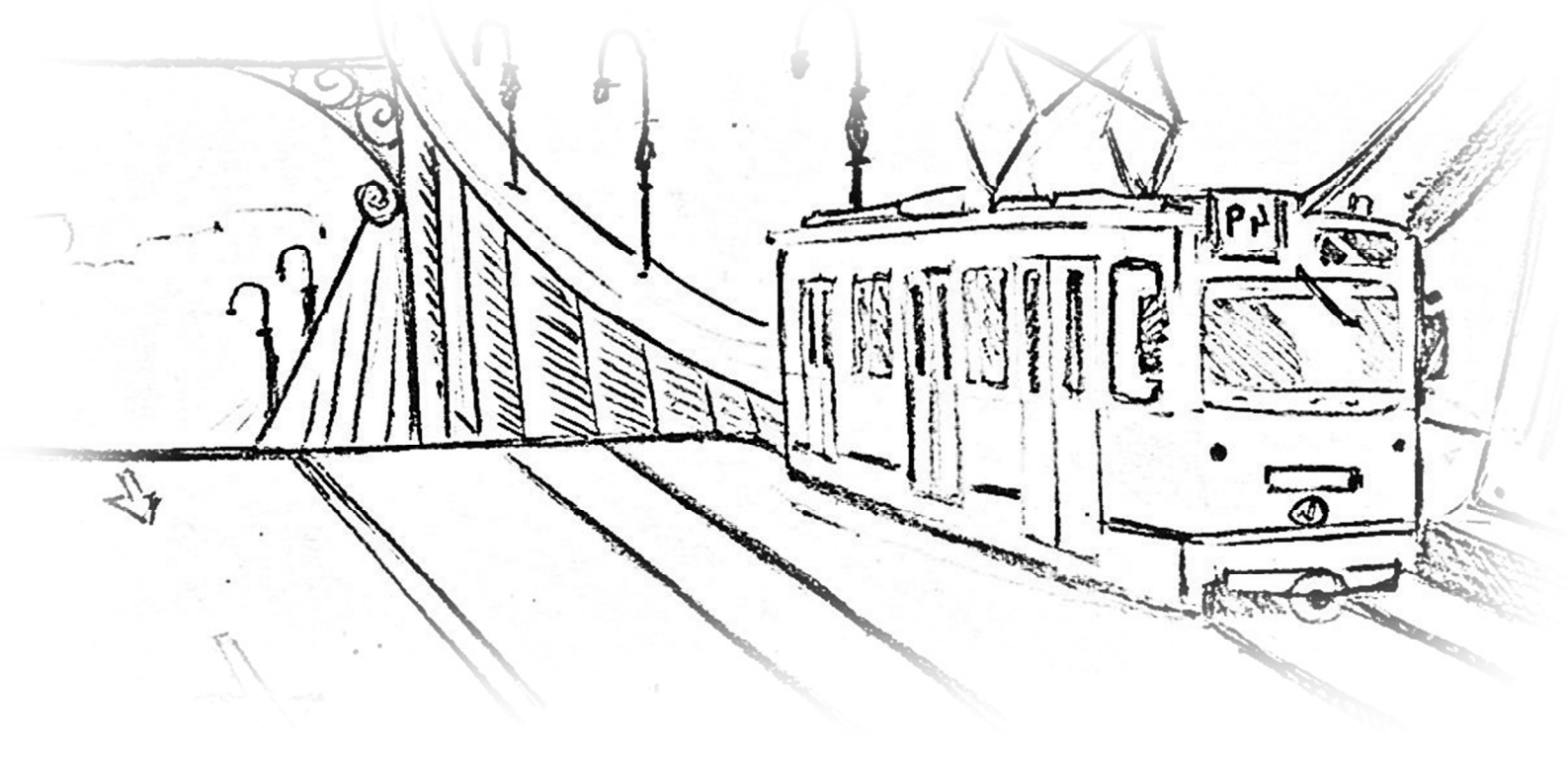

CHAPTER 1:

www.vialibre-ffe.com/noticias.asp?not=1233&cs=hist

CHAPTER 2:

<http://railsiferraduras.blogspot.com/2012/02/el-tram-de-la-bahia-de-swanea-pionero.html>

<http://habitat.aq.upm.es/boletin/n28/ajlord.html>

www.chasewaterstuff.wordpress.com

Museum of Technology Szczecin

50 JAHRE STETTINER STRASSENBAHN 1879-1929

CHAPTER 3:

<http://es.scribd.com/doc/29908522/COMENTARIO-PLANO-URBANO-VALENCIA>

<http://www.slideshare.net/juanmartin1/plano-de-valencia-comentario>

<http://sedina.pl/wordpress/index.php/2012/07/07/szczecinskie-przemiany-linsingenstrasepotulicka/>

<http://sedina.pl/wordpress/index.php/2004/11/13/nowa-tosamo-szczecin-1945-1970-odc-6-architekci-i-konserwatorzy/>

CHAPTER 4:

http://www.most.gov.mm/techuni/media/CE4017_09.pdf

<http://www.arcelormittal.com/rails+specialsections/es/carril-tranvia.html>

<http://www.apie.com.ar/Boletines/boletin-19/tranvias.html>

http://www.vialibre-ffe.com/PDF/ERS_23_09_2008def.pdf

<http://www.bathtram.org/tfb/tLR55.htm>

CHAPTER 5:

5.2 Type of materials and suitability

<http://www.giteco.unican.es/giteco/Publicaciones/AYC30-X-2000.pdf>

www.aenor.es

<http://webdelprofesor.ula.ve/ingenieria/nbelandria/materias/geotecnia/Geotextiles.pdf>

<http://www.alfredofenollar.com/pdf/Contour.pdf>

<http://www.andece.org/index.php/tipospavimentos/bordillos/9-andece>

<http://www.technoform.es/aluminium-and-tb/product-solutions/bio-based-polyamide>

<http://modasostenible.wordpress.com/tejidos-sostenibles/poliester-reciclado-mecanicamente/>

<http://prezi.com/cgkklgmielq/recoleccion-y-procesamiento-del-polietileno-y-polipropileno/>

http://manualdeusoymantenimiento.generadordeprecios.info/Urbanizacion_interior_de_la_parcela/Pavimentos_exteriores/Baldosas_y_losetas_de_hormigon.html

[http://www.aecarretera.com/cdc/OFICEMEN.%20ES-](http://www.aecarretera.com/cdc/OFICEMEN.%20ES-Pavimentos%20de%20hormign.%20Alternativa%20sostenible%20EUPAVE.pdf)

[Pavimentos%20de%20hormign.%20Alternativa%20sostenible%20EUPAVE.pdf](http://www.aecarretera.com/cdc/OFICEMEN.%20ES-Pavimentos%20de%20hormign.%20Alternativa%20sostenible%20EUPAVE.pdf)

<http://www.arcelormittal.com/rails+specialsections/es/noticias/2012/carril-para-tranvia-carril-embebido-de-garganta-y-compacto.html>

<http://www.insht.es/InshtWeb/Contenidos/Documentacion/NTP/NTP/Ficheros/926a937/958w.pdf>

<http://www.construccionenacero.com/Articulos%20y%20Publicaciones/Revistas/LA%20Sustentabilidad%20del%20Acero%20y%20Las%20Estructuras%20Met%C3%A1licas.pdf>

<http://www.parro.com.ar/definicion-de-barandilla>

http://oa.upm.es/12772/1/INVE_MEM_2011_107305.pdf

<http://www.alueurope.eu/wp-content/uploads/2011/08/La-sostenibilidad-del-aluminio-en-la-edification.pdf>

http://www.vidasostenible.org/observatorio/f2_final.asp?idinforme=592

5.3 Material-temperature-resistance relationship

<http://www.climatedata.eu/climate.php?loc=plxx0025&lang=es>

<http://www.registrocdt.cl/registrocdt/www/admin/uploads/docTec/0426112591037434454A24.pdf>

<http://www.zonaclima.com/climate/poland/fahrenheit/szczecin.htm>

<http://riunet.upv.es/bitstream/handle/10251/12793/Evoluci%C3%B3n%20resistencia%20hormig%C3%B3n.pdf?sequence=3>

5.4 Equipment used

www.abilin.ru

www.htsalescompany.com

www.cccme.org.cn

www.images.harborfreight.com

<http://www.ecured.cu/>

<http://profex.educarex.es/>

<http://www.ritchiespecs.com/>

<http://www.wme.cn/TruckMountedCrane/>

<http://www.lineapreencion.com/ProjectMiniSites/IS41/html/cap-1/cap2.htm>

<http://www.maquinariaspesadas.org/>

<http://www.seguridadsalud.ibermutuamur.es/>

<http://metrotrujillo.blogspot.com/2010/01/algunos-datos-tecnicos-del-tranvia-de.html>

<http://www.tramvia.org/trambesos/trambesos-via.htm>

5.5 Execution process

<http://metrotrujillo.blogspot.com/2010/01/algunos-datos-tecnicos-del-tranvia-de.html>

<http://www.tramvia.org/trambesos/trambesos-via.htm>

CHAPTER 6:

www.tph-bausysteme.com

www.librosmaravillosos.com

<http://szczecin.gazeta.pl/>

www.radioszczecin.pl

www.patologiasconstruccion.net

www.cnrt.gob.ar

www.ehowenespanol.com

www.cnrt.gob.ar

www.patologiasconstruccion.net

CHAPTER 7:

www.insht.es

CHAPTER 10:
GRATEFULNESSES

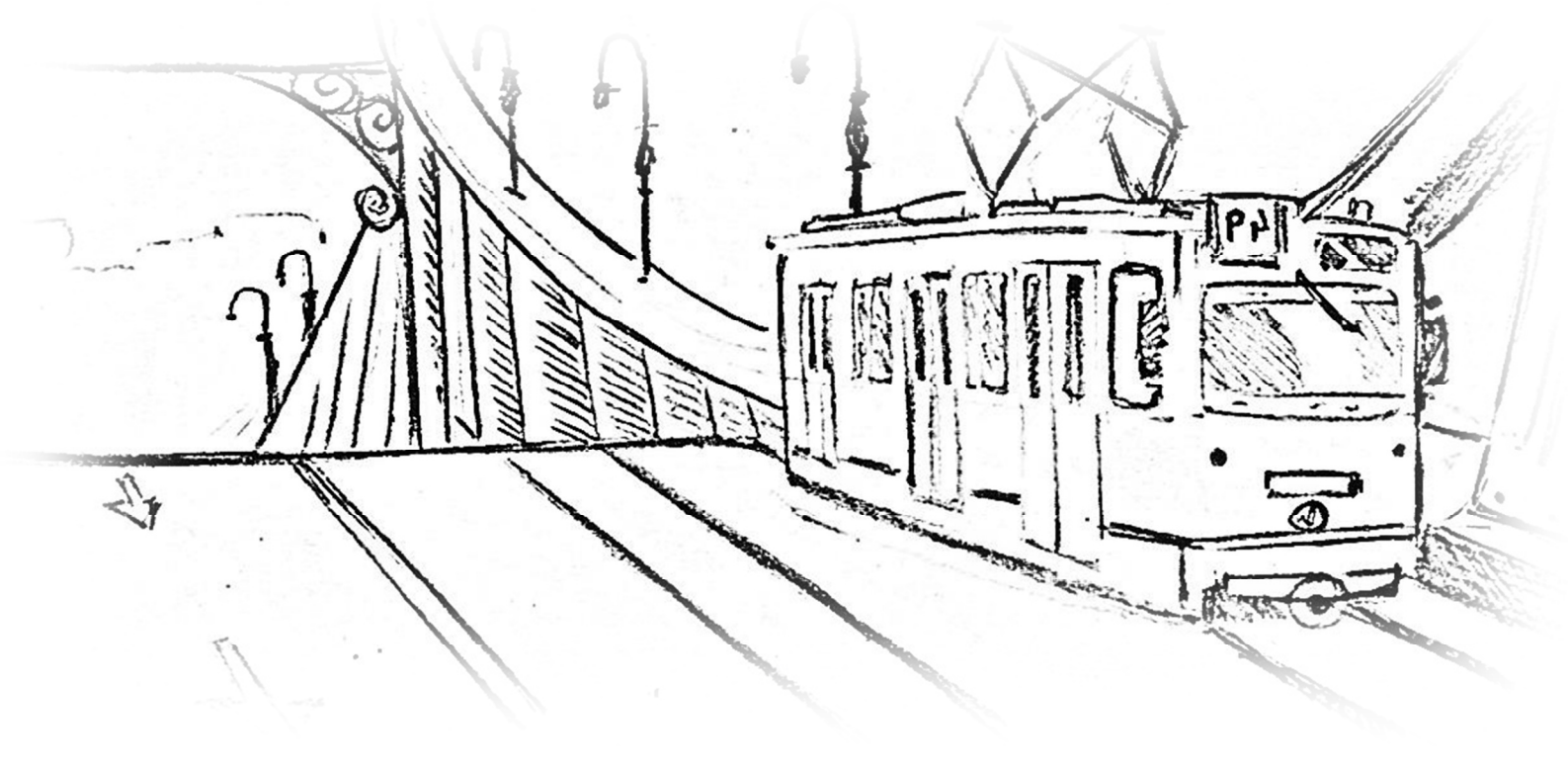

We would like that these words serve to express our profound and sincere gratitude to all people who have collaborated with their help directly or indirectly in the realization of this project, reading, reviewing, editing, having us patience, giving encouragement and accompanying us in times of crisis and in times of happiness.

Firstly thank Dr. Andrzej Pozlewicz tutor of our final project grade in Szczecin. Thanks for all the information provided, without which the project would not have been able to develop such an efficient manner. From him we learned numerous stories about Szczecin as well as new projects in the city.

We also thank our tutor project of the Universitat Politècnica of Valencia, Esther Valiente, for guiding us, without she we wouldn't have known where to start, for supporting us all these months and for all the interest shown towards us not only in the academic field, but also in personal life.

This project couldn't have been completed without the help of Fatima, Laura and Cris, who have provided us all information regarding Valencia (photographs, measurements, etc). Thanks also to Nacho and Victor for their artistic talents without them the design of this project wouldn't have been the same. And of course, Mayte, thanks for helping us to improve our English.

Thanks to the Erasmus organization, for giving us the opportunity to do this project in the West Pomeranian University of Technology, and meeting new cultures, cities and especially great people.

To our colleagues from Erasmus; Luis, Miguel and Maria Dolores, for their support during the most difficult times, encouraging and supporting us even when they weren't here with us.

Special thanks to Kuba for his advice and assistance with the language, but mostly for being there whenever we needed him both as regards the project as in our day to day.

Finally, thanks to our families and friends without them this experience would not have been possible.

Nos gustaría que estas palabras sirvieran para expresar nuestro más profundo y sincero agradecimiento a todas aquellas personas que con su ayuda han colaborado directa o indirectamente en la realización del presente trabajo leyendo, opinando, corrigiendo, teniéndonos paciencia, dando ánimo y acompañándonos tanto en los momentos de crisis como en los momentos de felicidad.

En primer lugar agradecer al Dr. Andrzej Pozlewicz, tutor de nuestro proyecto final de grado en Szczecin. Gracias por toda la información facilitada, sin la cual el proyecto no se habría podido desarrollar de una forma tan eficiente. De él hemos aprendido numerosas historias de Szczecin así como nuevos proyectos de la ciudad.

También queremos dar las gracias a nuestra tutora de proyecto de la Universitat Politècnica de Valencia, Esther Valiente, por guiarnos, sin ella no habríamos sabido por dónde empezar, por apoyarnos durante todos estos meses y por todo el interés que ha mostrado hacia nosotras no sólo en el ámbito académico, sino también en aspecto personales.

Este proyecto no se habría podido completar sin la ayuda de Fátima, Laura y Cris, las cuales nos han aportado información relativa a Valencia (fotografías, mediciones, etc...) Gracias también a Nacho y a Víctor por sus dotes artísticas, sin ellos el diseño de este proyecto no habría sido el mismo. Y por supuesto, a Mayte, gracias por ayudarnos a mejorar nuestro inglés.

Gracias a la organización Erasmus, por darnos la oportunidad de realizar este proyecto en la West Pomeranian University of Technology, conociendo así nuevas culturas, ciudades y sobretodo grandes personas.

A nuestros compañeros de Erasmus; Luis, Miguel y M^a Dolores, por su apoyo durante los momentos más duros, animándonos y apoyándonos incluso cuando ya no estaban aquí con nosotras.

Especial reconocimiento a Kuba por sus consejos y ayudas con el idioma, pero sobre todo por estar ahí siempre que lo hemos necesitado tanto en lo referente al proyecto como en nuestro día a día.

Por último a nuestras familias y amigos sin ellos esta experiencia no habría sido posible.