

Computational tool for experimental refrigeration system analysis using spreadsheets

HERRAMIENTA COMPUTACIONAL PARA ANALIZAR UN SISTEMA EXPERIMENTAL DE REFRIGERACIÓN USANDO HOJAS DE CÁLCULO



DOI: <http://dx.doi.org/10.6036/7255> | Recibido: 28/07/2014 • Aceptado: 18/09/2014

JM Mendoza-Miranda¹, JM Belman-Flores¹,
A Gallegos-Muñoz¹, A Mota-Babiloni² y J Navarro-Esbrí²

¹ UNIVERSIDAD DE GUANAJUATO. División de Ingenierías. Campus Irapuato-Salamanca. Carretera Salamanca-Valle de Santiago km 3.5+1.8 - 36885 Comunidad de Palo Blanco. Salamanca (México). Tel.: +52 464 6479940. jfbelman@ugto.mx

² UNIVERSIDAD JAUME I. Dpto. de Ingeniería Mecánica y Construcción. Campus Riu Sec, s/n - 12071 Castellón

RESUMEN

- Este trabajo presenta una aplicación de hojas de cálculo para el filtrado de datos y análisis energético, el cual tiene su aplicación en la investigación y evaluación experimental del desempeño energético de refrigerantes alternos. El sistema experimental de compresión de vapor (sistema de refrigeración) genera una gran cantidad de datos, los cuales son almacenados en archivos de texto de tamaño variable. Los archivos de texto contienen diferentes parámetros como: temperatura, presión, flujo másico y consumo energético, estas medidas se toman a la entrada y salida de cada componente del banco experimental. La herramienta computacional desarrollada procesa la información usando las funciones de las hojas de cálculo y programación en Visual Basic para aplicaciones (VBA), así como la conexión con las librerías dinámicas del REFPROP para las propiedades termo-físicas de los refrigerantes. Resulta una aplicación amigable para el usuario (estudiantes de ingeniería, investigadores, etc.), incluso sin que el usuario tenga la necesidad de programar en VBA y sin conocimiento e iteración con librerías dinámicas del REFPROP.
- **Palabras clave:** estado estable, análisis de datos, visualización gráfica, sistema de compresión de vapor.

ABSTRACT

This paper presents a spreadsheet application for data filtering and energy analysis, which has applications in research and experimental evaluation of the energetic performance of alternative refrigerants. Experimental vapor compression system (refrigeration system) generate a large amount of data, which is stored in text files of variable size. Text files contain different parameters such as: temperature, pressure, mass flow rate and power consumption, measured at the inlet and outlet of each component of the test bench. This computational tool processes information using spreadsheet functions and programming in Visual Basic for Applications (VBA) capabilities as well as the connection with the REFPROP dynamic libraries for thermophysical properties of refrigerants. The resulting application is user friendly (for engineering students, researchers, etc.), even without VBA programming and interaction of dynamic libraries of REFPROP knowledge by the user.

Keywords: steady state, data analysis, graphical visualization, spreadsheets, vapor compression system.

1. INTRODUCTION

Research and experimental energetic evaluation of alternative refrigerants with low *Global Warming Potential* (GWP) in the field of refrigeration, has an important role due to environmental issues addressed in recent years. Experimental research in this field is carried out in many universities and research centers that have vapor compression systems. The experimental test bench that is used for this purpose generates large amounts of data due to the wide range of operating conditions that can be studied. Therefore filtering and analysis of experimental data gathered is a challenge because it is time consuming and requires the use of specialized software, since a single data file can contain many transient and steady state data from different combinations of operating conditions. A solution to this problem is the development of computational software that will result in a viable tool to successfully complete the task. Among all programs available, Microsoft Excel® is a valid option based on spreadsheets that can be used for this purpose. In recent years, Excel has become a respected development platform alongside those based on C++, Java and .NET [1]. Although the use of spreadsheets was intended for its use in business accounting [2], the ubiquity and simplicity of Excel, in addition to its rich library of built-in func-

tions, such as plotting capabilities and other built-in utilities, has made it an attractive tool for engineering as well as for other disciplines. In the open source literature, many papers deal with the use of spreadsheets. For example, Lowry and Thomas [3] used spreadsheets to calculate daytime luminance of rooms using first-principle calculations for customizable sky luminance and glazing material properties. The resulting model can be used to analyze the effect of altering properties and sky conditions without specialized software. Ayala et al. [4] developed spreadsheet applications for processing large EEG files. This resulted in an application with tabular visualization, tools for table processing and the possibility to subdivide tables when the memory requirements exceed capacity. Cheetancheri and Cheng [5] presented an application for mechanism analysis and animation. This application allows users to develop and solve complicated planar mechanism problems. Aliane [6] explored the possibility of interfacing Excel with external hardware, and demonstrated the use of VBA programming language to perform data acquisition and real-time control. Iglesias et al. [7] presented an elemental simulator of chemical processes (SimPro) developed on Excel associated with VBA programming language. The application allows carrying out mass and energy balances, equipment dimensions and cost evaluations. Morishita et al. [8] demonstrated that the fluid dynamics equations could be solved efficiently using spreadsheets. They present three typical problems using *Spreadsheets Fluid Dynamics* (SFD) using conventional spreadsheets calculations, matrix inverse, vector product functions, and iteration. Jordan [9] used spreadsheets to solve thermal radiation problems specially related with multi-surface enclosures. He concluded that spreadsheets provide a convenient and flexible tool to solve these problems.

As shown in the literature review, there is no record on the use of Excel for experimental data analysis and filtering applied to experimental vapor compression systems. So, the aim of the present work is oriented towards developing a simple, user-friendly spreadsheet application for energy analysis and for filtering experimental data obtained from a vapor compression plant in the research of new refrigerant alternatives. This application takes advantage of several spreadsheet features such as macro programming, in-cell formulas as well as its connectivity with dynamic libraries for fluid thermophysical properties. As a result, the application is a useful tool in evaluating energy performance and data filtering for a wide variety of operating conditions and refrigerants.

The rest of paper is organized as follows: section 2 describes the experimental test bench used as well as a description of the measuring system. Section 3 presents the strategy and requirements for the application as well as the formulation of the key parameters used to analyze the performance of the system. Section 4 presents the application capabilities through an example showing its implementation. Finally, the main conclusions are summarized.

2. EXPERIMENTAL TEST BENCH

The refrigeration test facility (based on vapor compression technology) that was used to obtain experimental data is shown in Fig. 1. The experimental plant is located at the

Department of Mechanical Engineering and Construction of the *University Jaume I*, Spain.

The computational tool that was developed in this work pretends to reinforce the understanding of refrigeration systems and better explain ways in which experimental information can be handled and analyzed inside teaching refrigeration groups and applied research with the international collaboration between universities research groups.

The experimental test bench consists of three loops: a vapor compression circuit and two secondary loops to simulate different refrigeration loads and condensing conditions. The vapor compression circuit can work in two different configurations: as a single-stage vapor compression system and as a vapor compression system with an internal heat exchanger (IHX). The configuration of the refrigeration system is controlled by a system that automatically opens or closes valves.

In Fig. 2, a schematic diagram shows the location of the valves to control the system's configuration as well as the location of the instrumentation to collect experimental data. The main components of the vapor compression plant are: compressor, condenser, expansion valve, internal heat exchanger and evaporator. The compressor that was used is an open-type variable speed compressor; a shell-and-tube evaporator type is mounted, where the refrigerant flows inside the tubes and a brine water-propylene glycol (35/65% by volume) is used as a secondary fluid; it includes a shell-and-tube condenser, with refrigerant flowing along the shell and the water inside the tubes, a concentric corrugated tube as internal heat exchanger where the liquid refrigerant flows by the annulus and the vapor refrigerant flows inside the internal tube and a set of expansion valves. The experimental setup is complemented with two secondary circuits used to control secondary fluid conditions in the inlet of the evaporator and in the condenser in order to simulate and control different working conditions for the refrigeration system.



Fig. 1: Experimental test bench

Notice that in the bench, changes can be made in its main elements, for example, changes in the heat exchange equipment as well as any other volumetric compressor. However, for purpose of the tool developed and presented in this work,

only changes in the configuration of the installation are taken into account.

2.1. MEASUREMENT SYSTEM

The main thermodynamic states shown in Fig. 2, are obtained by measuring temperature and pressure in the inlet and outlet of each basic element of the installation using thermocouples and piezoelectric pressure transducers, respectively. The thermocouples are calibrated in our own laboratory using certified references, with an uncertainty of ± 0.3 K, while the pressure transducers within a range of 0-3 MPa have an uncertainty of $\pm 0.1\%$. The measurement of the refrigerant mass flow, \dot{m}_r , is obtained by a Coriolis effect mass flow meter located on liquid line, with a certified accuracy of $\pm 0.22\%$ on reading. The volumetric flow for secondary fluids in the evaporator and the condenser, \dot{V}_w and \dot{V}_g , are measured using electromagnetic flow meters with a certified accuracy of $\pm 0.25\%$. All of these measured parameters are essential to obtain the rest of the thermo physical properties using the REFPROP [10] database. Table I summarizes the measured variables and the type of measuring instrument used in different loops of the experimental plant.

The signals generated by all sensors, as well those provided by the measuring devices, were gathered using a PC-based data acquisition system SCXI 1000 from National Instruments. All data are obtained with a sampling period of 0.5 seconds.

3. APPLICATION DEVELOPMENT

The approach that was used to develop the application is shown in Fig. 3, where we observe that the proposed solution is carried out in three steps: acquisition of data in real time, data filtering processing and displaying the results. In the first step, the information is loaded by the user who uploads the pertinent information about the configuration of the test bench. This facility is flexible to work with two configurations, with or without IHX (see Fig. 2). The expansion process also has two types of device: electronic and thermostatic expansion valves. Furthermore, refrigerant type (such as HFO-1234yf and HFO-1234ze, R407C, among others) and propylene glycol brine concentration, allow to the user define the configuration of the test bench used and loading the file generated by DAQ system with the data from the experimental test bench. With the information recorded in the first step, the application calls dynamic libraries of REFPROP to determine thermodynamic properties in each thermodynamic state that was measured, this is done by using the features available in Excel and calling procedures developed in VBA (*Visual Basic for Applications*) to optimize the calculation time in the energy analysis. The information is then filtered. Finally, an energy analysis for the complete experimental vapor compression system is carried out and each component for steady state conditions are obtained.

The main problems found while working with data generated by experimental vapor compression systems are due to several factors; the configuration of the vapor compression system (with or without IHX), refrigerant type, propylene glycol brine concentration, and the size of the data file generated by the DAQ system. The guidelines to develop the application are listed below:

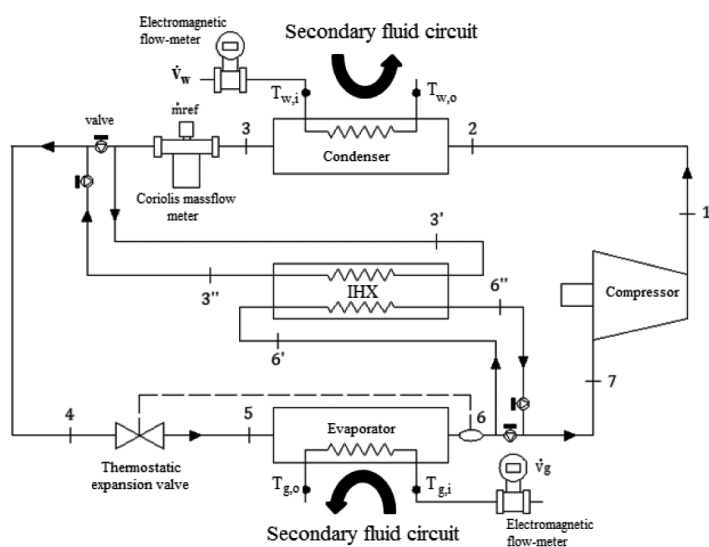

Fig. 2: Vapor compression plant scheme

| Loop | Variable measured | Sensor type | Number of sensors | Uncertainty |
|---------------------------|------------------------|---------------------------------|-------------------|--------------|
| Vapor compression circuit | T | K-type thermocouple | 12 | ± 0.3 K |
| | P | Pressure transducers | 8 | ± 0.1 % |
| | \dot{m}_{ref} | Coriolis-effect mass flow meter | 1 | ± 0.22 % |
| | Pot_c | Digital wattmeter | 1 | ± 0.5 % |
| | N | Inductive sensor | 1 | ± 1 % |
| Secondary circuits | T | Immersion-type thermocouples | 4 | ± 0.3 K |
| | \dot{V}_w, \dot{V}_g | Electromagnetic flow meter | 2 | ± 0.25 % |

Table I: Measured parameters

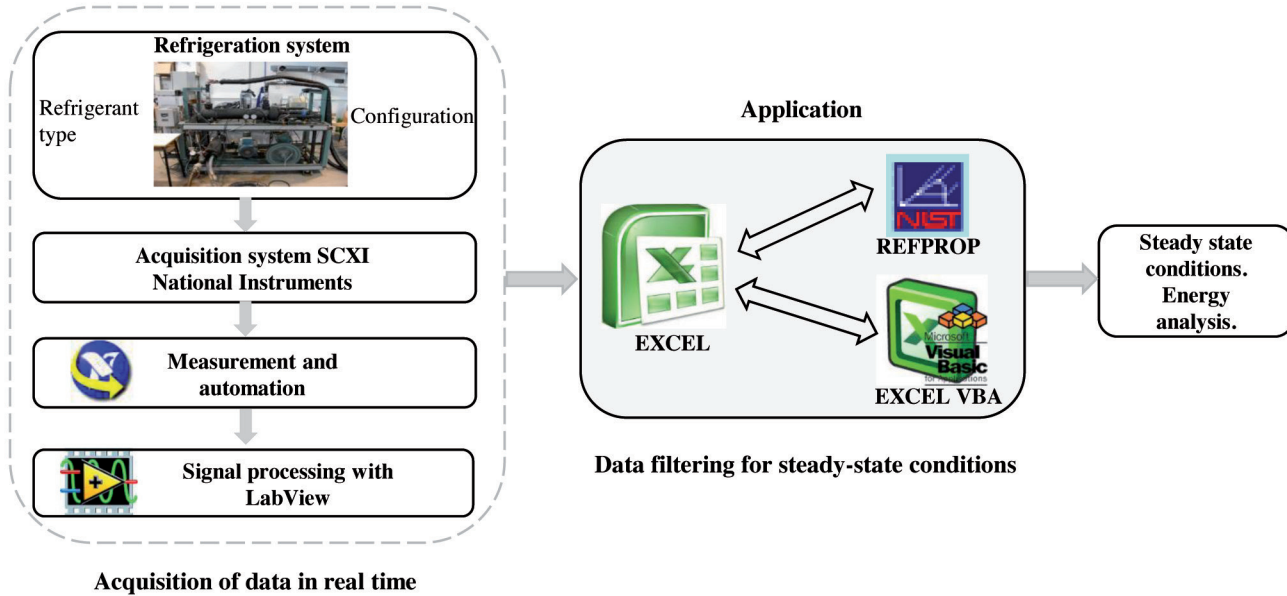

Fig. 3: General approach to develop the application

Selection capability of the configuration used in the test bench for analysis. This option should include refrigerant type, percentage of propylene glycol brine used in the evaporator, single stage or with internal heat exchanger (IHX) as well as the type of expansion device used.

Resizing according to the size of data file. This is an important feature because the information collected varies according to the time expended while evaluating experimental test bench operating conditions. It means that the number of contiguous rows in the spreadsheet varies with the information, so, the energy calculation must be adaptable to the experimental information collected.

Data filtering. The application must have an option for data filtering and a feature that allows resizing and refreshing all information and graphics. This feature permits separate between transient data and steady state data obtained, establishing a range of variation and using the previous feature, show only interest data (steady state energy analysis).

Energetic performance results. The application must show the average energetic performance as well as the standard deviation for experimental data for the complete test bench. Additionally, individual energetic analysis for each main component should be presented.

Graphical results visualization. Graphical results must automatically fit the amount of data. This feature includes the visualization of the behavior of key measured variables such as outlet temperatures, T , and pressures, P , at condenser and evaporator, sub-cooling degree, SCD , superheating degree, SHD , volumetric flow rate of secondary fluids, V_w, V_g , refrigerant mass flow rate, \dot{m}_{ref} , and from thermal analysis, the information that must be displayed includes the cooling capacity for the evaporator, \dot{Q}_o , heat removed at the condenser, \dot{Q}_k , as well as volumetric, η_v , isentropic, η_s , and combined, η_{comb} , compressor efficiencies and for the performance refrigeration system COP .

The developed application is able to adapt to different assemblies based on the data acquisition system, provided that the facility is based on vapor compression. The contribution

of the tool is aimed to the energy evaluation of the system at steady state, the transient performance in this application is of no interest.

3.1. PHYSICAL THEORY FOR ENERGY ANALYSIS

The aim of experimental energy evaluation of new refrigerants is to evaluate its behavior in actual compression systems using refrigerants that need to be replaced. For this purpose, each component of the refrigeration system and the complete system are studied using thermodynamic theory, besides geometric characteristics and measured parameters such as power consumption or refrigerant mass flow rate. Physical constants for each component of the experimental test bench are shown in Table II, which includes the physical theory for the compressor, condenser, evaporator, IHX, expansion valve and the energetic performance of the refrigeration system. The main parameters for the compressor are volumetric, isentropic and combined efficiencies. These parameters determine the performance of the compressor under defined operating conditions. The parameters that define energy behavior for the heat exchangers are heat transfer rate and overall heat transfer coefficient. The thermal analysis of the heat exchangers is based on the logarithmic mean temperature difference method. This method is a logarithmic average of the temperature difference between the hot and cold streams at each end of the exchanger. The larger, ΔT_{lm} , the more heat is transferred. Finally, the expansion device is modeled as an isenthalpic process.

4. RESULTS

Based on the physical theory for energetic analysis of test bench components and their performance, the application was developed using spreadsheets features. In this section, the windows and spreadsheets used in the application that was developed are described.

When the application starts, a main screen appears, is shown in Fig. 4. This screen is a spreadsheet containing the



| | |
|---|---|
|  | $\eta_v = \frac{60\dot{m}_{ref}}{\rho_7 V_G N} \quad (1)$ |
| Compressor | $\eta_s = \frac{h_{1,s} - h_7}{h_1 - h_7} \quad (2)$ |
| | $\eta_{comb} = \frac{\dot{m}_{ref} (h_{1,s} - h_7)}{Pot_c} \quad (3)$ |
|  | $\dot{Q}_k = \dot{m}_{ref} (h_2 - h_3) = \rho_w \left(\frac{\dot{V}_w}{3600} \right) c_{p,w} (T_{w,o} - T_{w,i}) \quad (4)$ |
| Condenser | $U_k = \frac{\dot{Q}_k}{A_k (\Delta T_{ml})_k} \quad (5)$ |
| | $(\Delta T_{ml})_k = \frac{(T_2 - T_{w,o}) - (T_3 - T_{w,i})}{\ln \left(\frac{T_3 - T_{w,i}}{T_2 - T_{w,o}} \right)} \quad (6)$ |
| | $SCD = T_{cond} - T_3 \quad (\text{single stage}) \quad (7)$ |
|  | $\dot{Q}_o = \dot{m}_{ref} (h_6 - h_5) = \rho_g \left(\frac{\dot{V}_g}{3600} \right) C_{p,g} (T_{g,i} - T_{g,o}) \quad (8)$ |
| Evaporator | $U_o = \frac{\dot{Q}_o}{A_o (\Delta T_{ml})_o} \quad (9)$ |
| | $(\Delta T_{ml})_o = \frac{(T_{g,i} - T_6) - (T_{g,o} - T_{evap})}{\ln \left(\frac{T_{g,o} - T_{evap}}{T_{g,i} - T_6} \right)} \quad (10)$ |
| | $SHD = T_6 - T_{evap} \quad (11)$ |
|  | $\dot{Q}_{IHX} = \dot{m}_{ref} (h_3 - h_{3'}) = \dot{m}_{ref} (h_{6''} - h_{6'}) \quad (12)$ |
| IHX | $U_{IHX} = \frac{\dot{Q}_{IHX}}{A_{IHX} (\Delta T_{ml})_{IHX}} \quad (13)$ |
| | $(\Delta T_{ml})_{IHX} = \frac{(T_{3''} - T_{6'}) - (T_{3'} - T_{6''})}{\ln \left(\frac{T_{3''} - T_{6''}}{T_{3'} - T_{6'}} \right)} \quad (14)$ |
| | $SCD = T_{cond} - T_{3''} \quad (\text{with IHX}) \quad (15)$ |
|  | $h_4 = h_5 \quad (16)$ |
| Expansion device | |
| Coefficient of performance | $COP = \frac{\dot{Q}_o}{Pot_c} \quad (17)$ |

Table II: Physical fundamentals for each component of the experimental test bench

navigation bar on the top of the screen. This allows accessing the different spreadsheets that the application contains. Additionally, this screen contains a button labeled “Experimental Data Analysis”. When this button is pressed, the process of experimental data analysis begins, which collects information on; the date of the analysis, the percentage of propylene glycol as secondary fluid used in evaporator, refrigerant type, covering pure fluids and mixtures, the expansion valve (electronic and thermostatic) used, and the configuration of the vapor compression system, with or without IHX. When the thermostatic expansion valve is selected, the user needs to select the orifice type available in the test bench. Thus, when a data file is found, the user visualizes all the processed data and start

the filtering and reviewing the information generated by the energy analysis calculations.

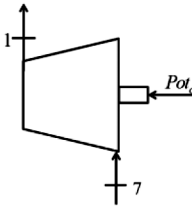
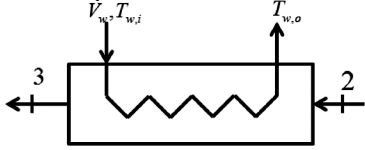
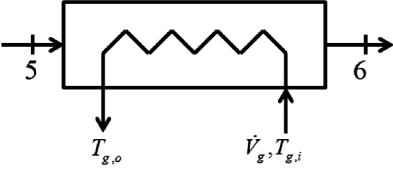
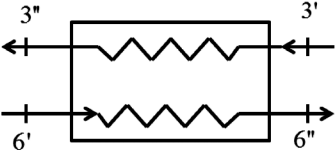
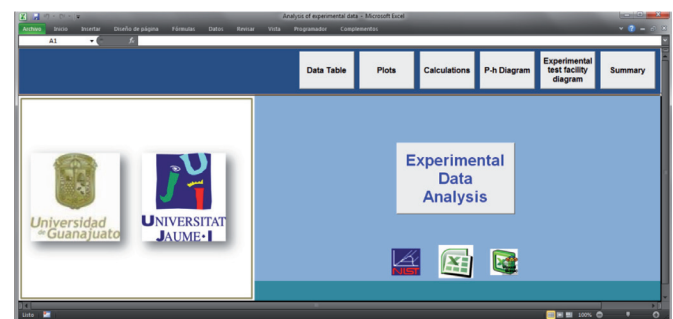

Fig. 4: Main screen when the application starts

Fig. 5: Loaded data and calculations

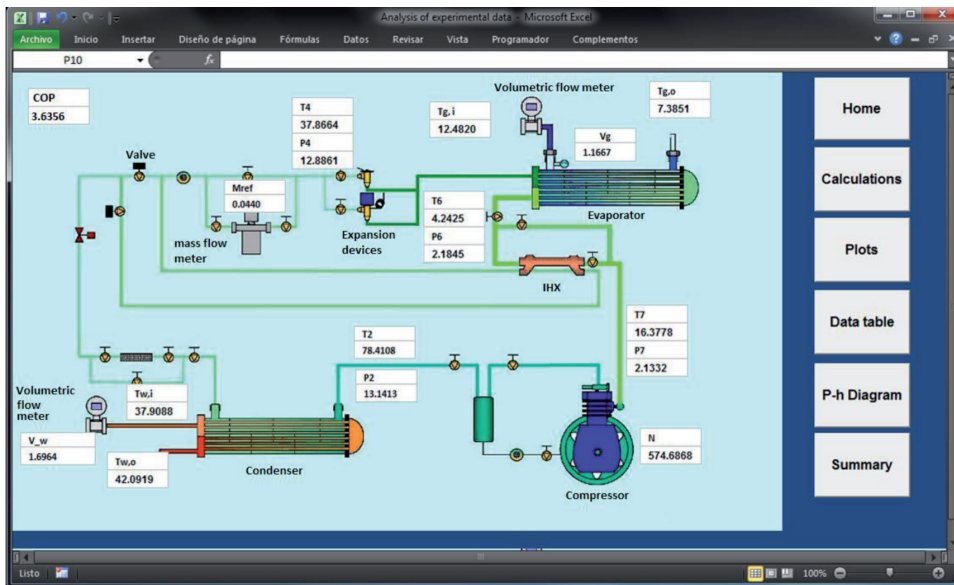

Fig. 6: Graphical visualization of the main variables and energetic parameters

From the main screen, and by using the navigation buttons, the user can access a spreadsheet labeled “Data Table” (Fig. 5). In this spreadsheet the experimental data are stored and the calculation of thermo physical properties are carried out for each thermodynamic state (see Fig. 2). By clicking the “Plots” button located in the navigation bar, the user can view the main variables that were measured and the parameters involved in the system’s energy analysis. From this spreadsheet (Fig. 6), the user can identify the temporality in measured parameters such as pressure, temperature and mass flow rate. Other parameters that the user can visualize include the energetic behavior of the test bench and its components. All plots contained in this spreadsheet show the average of the values along with the standard deviation of data. The deviation range of data is considered as one standard deviation, and it is shown as the dashed lines in Fig. 6. From the data table spreadsheet, the user can use the dynamic table’s tools to filter information. Data filtering is defined by the number of interest of the measured variables considering a reference value or interval (see Fig. 7).

Once the user has concluded filtering the data, the next spreadsheet, which appears under the button labeled as “Calculations”, is shown in Fig. 8. This spreadsheet shows the most important parameters for whole and individual components of the vapor compression system. This table highlights compressor efficiencies, overall heat transfer coefficient for each heat exchanger; and the main parameters that determine the working conditions of the test bench. This spreadsheet offers the energy analysis information of average experimental data for each component of the test bench in steady state conditions. The spreadsheet shown in Fig. 9, displays main thermodynamic properties for each component of the test bench with its graphical representation in a $p-h$ diagram corresponding to the refrigerant studied. The $p-h$ diagram is very useful to quickly identify the influence of IHX in the superheating and sub-cooling degree (SHD , SCD) parameters. The scheme of vapor compression system shown in Fig. 10 helps to identify each thermodynamic state represented at $p-h$ diagram in the test bench as shown in Fig. 9. Additionally, the user can view average values about refrigerant mass flow rate, secondary volumetric flow rates, and compressor speed.

Thus, the application presented in this paper is a very interesting tool in the energy evaluation of various systems of cold generation, either for refrigeration or air conditioning that is instrumented, and also either from the educational point of view of research or industrial level. In the latter, most facilities lack sophisticated systems of monitoring and evaluation for the performance of refrigeration systems, or in some others, it is impossible to analyze large performances of the system, and for this reason, this type of application turns to be an interesting tool from the practical, economical and functional point of view. Among its advantages, it includes the flexibility to adapt to other facilities (based on vapor compression cycle), keeping in mind that what is necessary for starting the analysis is the recording of data to be acquired in real time during the operation of the facility. Thus, the tool on an industrial level can be an add on maintenance issues in the compressor itself, as there are specific parameters in the spreadsheets that offer the performance of the pieces of equipment.

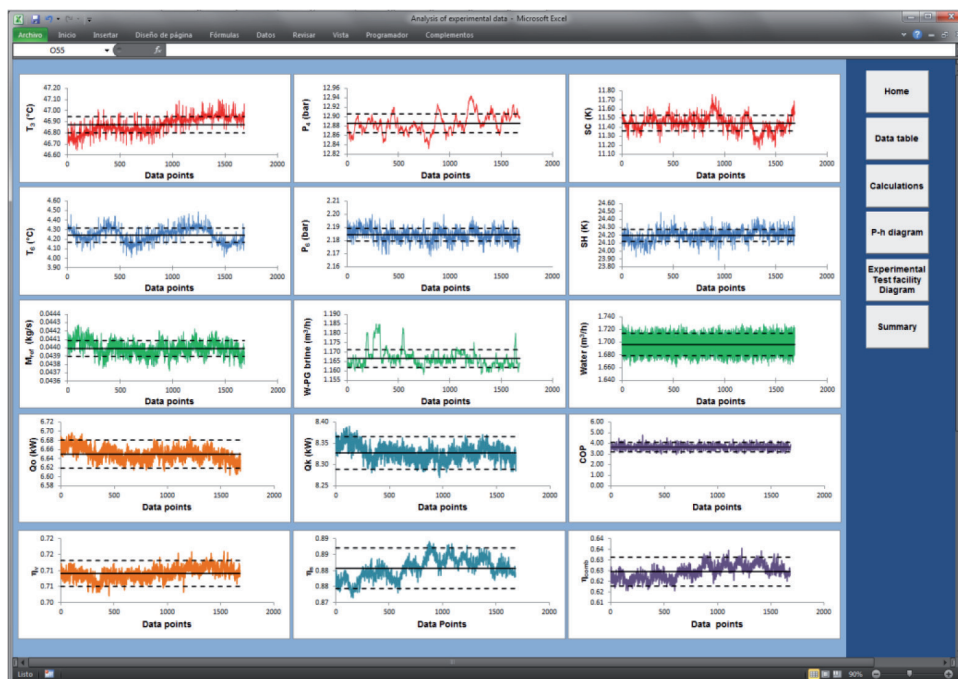

Fig. 7: Data filtering as a feature of dynamic table

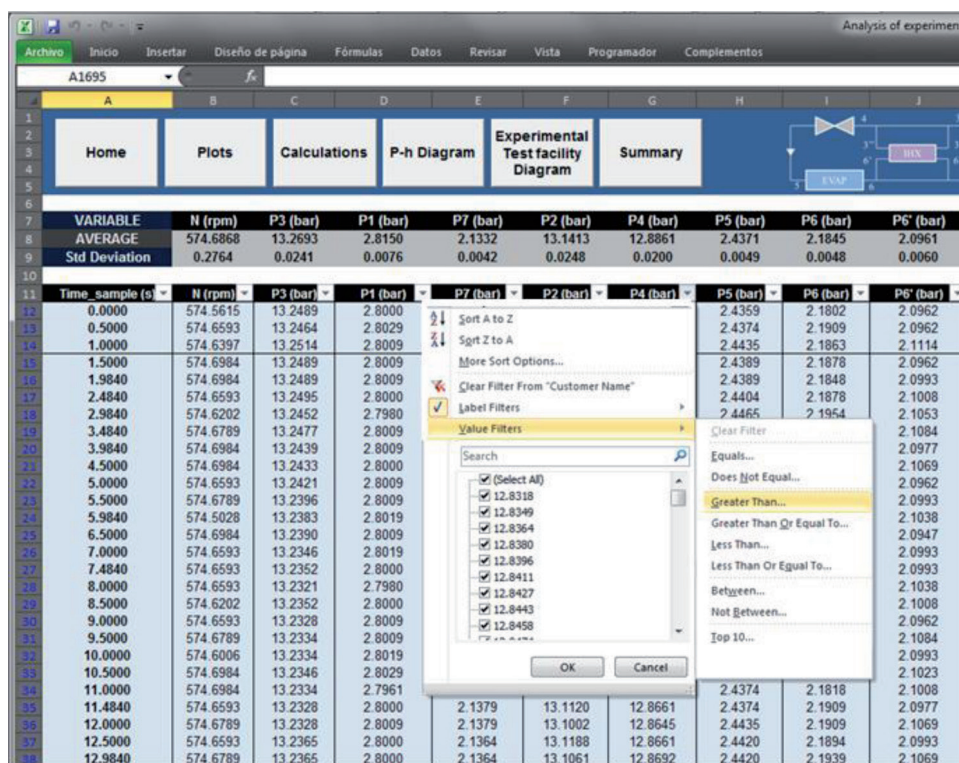

Fig. 8: Energetic calculations with average data for whole vapor compression and its components

4.1. EDUCATIVE EXPERIENCE

As mentioned above, the application of the spreadsheet data filtering and the energy analysis of the refrigeration system may be an user friendly application to engineering students. In this context, engineering educational programs seek to use software in different areas to help reinforce the student's education. Currently computer technology allows to create tools that optimize the degree of interactivity and the level of information retention in the teaching-learning process. Subjects as thermodynamics

and heat transfer are an area of immense importance in the academic development of mechanical engineering students with specialization in thermal fluids.

To evaluate the use of the computational tools as means of virtual laboratory, 17 intermediate students (third year) were included in the subject of Refrigeration and Air Conditioning, which is given for a period of 12 weeks, with 3 hours of class per week. The purpose of using the tool consisted primarily of: i) define the simple configuration of the experimental setup, ii) assign a conventional refrigerant as the working fluid (R134a), iii) search and load of the file under certain operating conditions, iv) once the steady state of the system was evaluated, the student must reproduce the information obtained in respect to the energy performance of the facility, COP. Finally, the student must repeat the above steps, but now, by assigning an alternate refrigerant as HFO-1234yf, in order to compare the energy performances between both refrigerants while corroborating what was found in the literature regarding the tendency of alternative refrigerants.

Thus, 76% of students who used the tool achieved the same results by using spreadsheets and expressing thermodynamic equations for each element of the installation. The student group concluded that the tool is easy, but under a prior knowledge of the theory of vapor compression systems, in addition, the tool displays particular parameters of heat exchange equipment and comprehensive information about the performance of the compressor, all this aspects strengthen the student's formation.

5. CONCLUSIONS

In this paper a spreadsheet application for filtering data and energetic analysis for experimental vapor compression system was presented. This application simplifies the work done in post-acquisition in experimental refrigeration. The main conclusions about this work can be summarized as follows: We showed that the use of Excel can be applied to the experimental data analysis in the field of refrigeration in the research of new refrigerant fluids. The application is very robust because

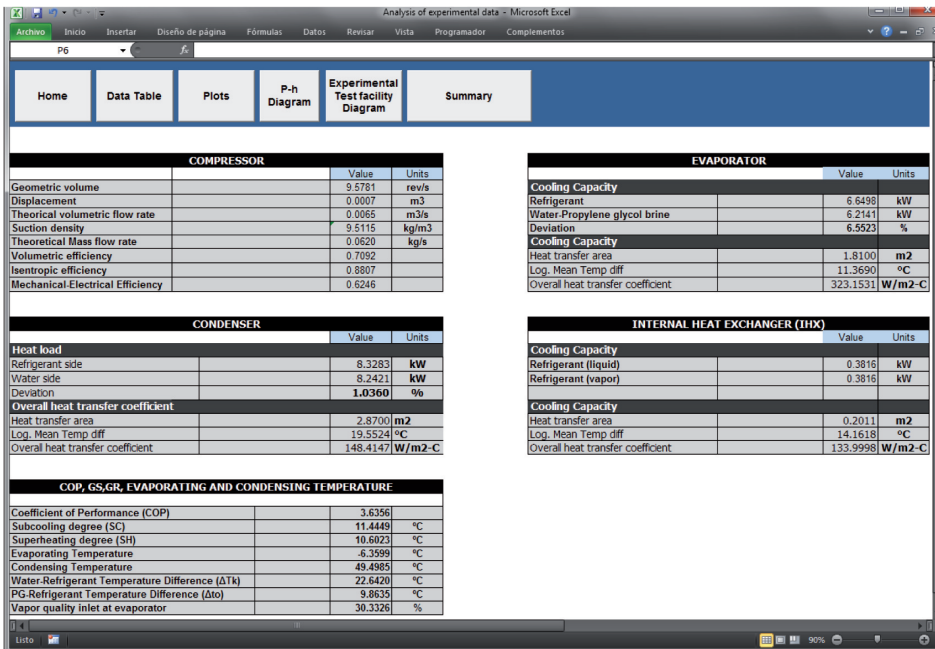

Fig. 9: Main thermodynamic states for experimental vapor compression and its representation in a p-h diagram

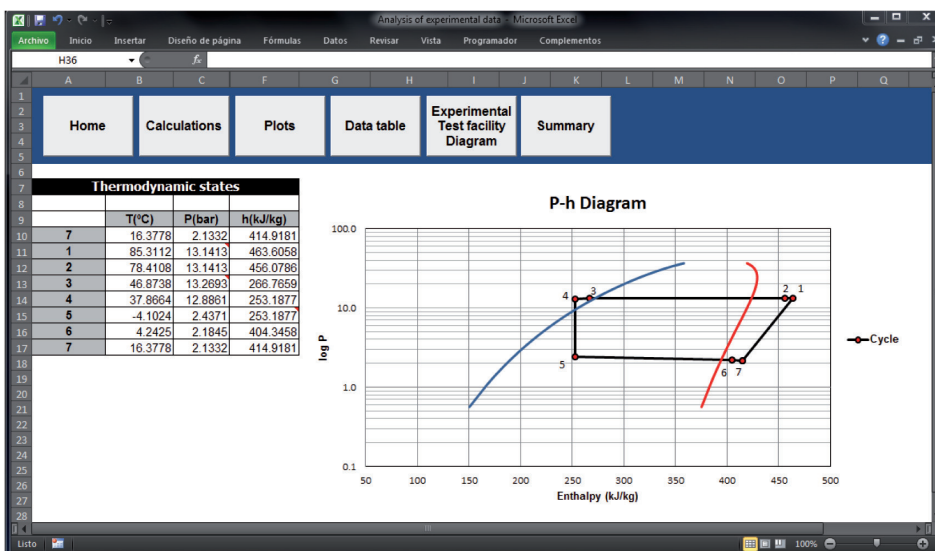

Fig. 10: Scheme of vapor compression plant with average values of measured variables

it can be use a wide range of fluids. The application can be used in both research and educational purposes. The resulting application is simple and user friendly for a wide range of people (namely engineering students, researchers, etc.) without prior knowledge of VBA programming or the interactions of dynamic REFPROP libraries. This application can be used on any computer, reducing both costs and time when compared with specialized data analysis software that needs to be bought for several computers. The user only needs to focus on energy analysis for each component of the vapor compression system and the performance of the system. The excellent features that Excel provides are used in the application, which allows working with variable size data text files as well as a wide range of refrigerant substances (pure and mixed).

This application results in a useful tool in the area of refrigeration research because it responds to the need for quick data analysis and evaluation of the performance of the system. This tool can be used in engineering education in order to strengthen the knowledge about the study of refrigeration in vapor compression system, a project in which the University of Guanajuato, and the University Jaume I have participated.

AKNOWLEDGEMENTS

We acknowledge DAIP, UG for the sponsorship for this work.

BIBLIOGRAPHY

- [1] Bovey R, Wallentin D, Bullen S, and Green J. *Professional Excel Development*. Second edition. Addison-Wesley, United States (2009). ISBN-13: 978-0321508799
- [2] Chehab A, El-Hajj A, Al-Husseini M, et al. "Spreadsheet Applications in Electrical Engineering: A Review". *Int. J. Engng Ed.* Vol.20 (2004) p.902-908.
- [3] Lowry G, and Thomas S. "Spreadsheet-based calculation tool for direct daylight illuminance adaptable for different glazing properties and sky models". *Build Environ.* Vol.45 (2010) p.1081-1086. DOI: <http://dx.doi.org/10.1016/j.buildenv.2009.09.017>
- [4] Ayala M, Cabrero M, Tito M, et al. "A spreadsheet application for processing long-term EEG recordings". *Comput Biol Med.* Vol.39 (2009) p.844-851. DOI: <http://dx.doi.org/10.1016/j.combiomed.2009.07.003>
- [5] Cheetancheri KG, and Cheng HH. "Spreadsheet-based interactive design and analysis of mechanisms using excel and Ch". *Adv Eng Softw.* Vol.40 (2009) p.274-280. DOI: <http://dx.doi.org/10.1016/j.advengsoft.2007.08.003>
- [6] Aliane N. "Data acquisition and real-time control using spreadsheets: interfacing Excel with external hardware". *ISA T.* Vol.49 (2010) p.264-269. DOI: <http://dx.doi.org/10.1016/j.isatra.2010.03.009>
- [7] Iglesias OA, Pastor J, Henseler A, et al. "Spreadsheets use in conceptual design of chemical processes". *Int. J. Engng. Ed.* Vol.20 (2004) p.999-1004.
- [8] Morishita E, Iwata Y, Yuki K, et al. "Spreadsheet fluid dynamics for aeronautical course problems". *Int. J. Engng. Ed.* 17 (2000) p. 294-311.
- [9] Jordan PJ. "A spreadsheet-based method for thermal radiation calculations". *Int. J. Engng. Ed.* Vol.20 (2004) p.991-998.
- [10] Lemmon EW, and McLinden ML. *Reference fluid thermodynamic and transport properties*. REFPROP version 8.0. NIST Standard Reference Database 23, Gaithersburg, MD. (2002).