

Alison and Peter Smithson:

The Transient and the Permanent



UNIVERSITAT
POLITÈCNICA
DE VALÈNCIA

ANA ÁBALOS RAMOS, SEPTEMBER 2015

SUPERVISORS: DIRK VAN DEN HEUVEL - DÉBORA DOMINGO CALABUIG

Alison and Peter Smithson: The Transient and the Permanent



UNIVERSITAT
POLITÈCNICA
DE VALÈNCIA

ANA ÁBALOS RAMOS, SEPTEMBER 2015
SUPERVISORS: DIRK VAN DEN HEUVEL - DÉBORA DOMINGO CALABUIG

Alison and Peter Smithson: The Transient and the Permanent

Exhibitions are a cornerstone of Alison and Peter Smithsons' multifaceted approach to their work. A powerful medium for conveying and materialising their ideas which provided them, throughout their career, with the opportunity to freely create experimental constructions to relay their thoughts.

The exhibitions they staged in the 1950s and 60s, such as 'Parallel of Life and Art', 'House of the Future', and 'Patio & Pavilion' were, and still are, at least as important to architectural critics as their few built works or many writings. However, from the 1970s onwards little is known about their prolific work in the realm of exhibitions.

In his lecture 'The Masque and the Exhibition: Stages Towards the Real' in 1980, Peter Smithson mentioned the importance of exhibitions in shaping the Smithsons' architecture as places of opportunity in which to experiment with reality. This comment makes it logical to think that if the exhibitions held before then had always been a powerful tool – a tool used, furthermore, by the Smithsons to create some of their most intense productions – then those staged after said lecture, which acknowledged and highlighted this aspect of their work might, despite being little known, be at least as intense as the previous exhibitions with greater media visibility. This idea, together with the expectations raised by the 'Christmas-Hogmanay' exhibition – not only because it was staged whilst said lecture was being drafted but also because of the ideas that sprang from the analysis of a related collage mentioned in the prelude to this doctoral thesis – channelled the research towards this final period of the Smithsons' exhibition architecture. The research herein focuses specifically on two groups of exhibitions that stand out amongst the Smithsons' wide range of documented exhibitions on account of their inherent intellectual cohesion enabling the concepts staged by Alison and Peter Smithson to be seen more clearly.

Firstly, Christmas, and specifically the popular traditions going hand in hand with this festivity, was the theme running through a series of four exhibitions staged by Alison Smithson between 1976 and 1981, including the enigmatic 'Christmas-Hogmanay' exhibition. The Christmas theme was, in fact, merely a vehicle for conveying the Smithsons' concern about the pressing need to renew the sense of collective responsibility for the look and use of places, at a time when, after vanishing from the London scene, the Smithsons were also carrying out a revision of their work that enabled them to refine their thinking until a new architectural discourse emerged which they presented, after reinterpreting it, in 1982 in *The Shift*. These

four exhibitions were, therefore, different phases in the Smithsons' on-going research which provided, at that crucial moment of intellectual renewal, a magnificent opportunity for experimentation during their quest for a receptive architecture able to underpin a renewed 'art of inhabitation'.

The second group consisted of a large number of exhibitions staged after the Christmas series, mainly in the 1980s and 90s, in connection with Axel Bruchhäuser and the German furniture factory, TECTA. Firstly Alison, until her death in 1993, and then Peter, until 2003, advised Bruchhäuser and helped with his annual presentations at furniture fairs (mainly the international furniture fairs of Cologne and Milan) by creating displays that were never merely commercial and always featured some significant intellectual concepts. This close partnership also provided opportunities to stage far more thought-provoking displays such as the 'TischleinDeckDich a.s.o.' exhibition, whilst not forgetting that the client was a furniture manufacturer – albeit a rather unusual one. The furniture was always the epicentre of the thinking behind the exhibitions in this group. Furniture that talks about architecture. The TECTA exhibitions represent a long period characterized, more than any other, by the unfettered and unconditional experimentation and implementation of the Smithsons' thinking. A final period of intellectual maturity that undoubtedly constitutes a marvellous architectural legacy.

This doctoral thesis consists of four chapters. It begins with an introductory chapter which firstly analyses and contextualises architecture in the shape of exhibitions; then outlines the importance of exhibitions in Alison and Peter Smithson's work; and finally puts the specific period under study into context in terms of both their career and the discourse of architecture in general.

The two main chapters in this thesis are entitled 'Christmas Exhibitions' and 'TECTA Exhibitions', each organised in a similar fashion: a short introduction to the group of exhibitions followed by an in-depth analysis of each exhibition in the group based mainly on the unpublished documentation to which the author had access in the three main archives devoted to Alison and Peter Smithson: The Alison and Peter Smithson Archive in the Special Collections Department of the Frances Loeb Library at Harvard Design School (USA); the Alison and Peter Smithson Archive / TECTA Archive at Lauenförde (Germany); and the Smithson Family Archive in Stamford (United Kingdom). Finally, each chapter ends with an essay which analyses and links up the different concepts conveyed by each individual exhibition and the exhibitions in the group as a whole.

The last chapter is a short epilogue that gathers up all the concepts set out previously in relation to the Christmas and TECTA exhibitions, and shows how they all tie in together in the Smithsons' most experimental work: the Hexenhaus at Bad Karlshafen.

Alison and Peter Smithson: Lo transitorio y lo permanente

Dentro del enfoque polifacético del trabajo de Alison and Peter Smithson, las exposiciones son pieza fundamental. Un medio poderoso para comunicar y materializar sus ideas que les brindó a lo largo de toda su trayectoria la oportunidad de abordar con libertad la construcción experimental de su pensamiento.

Sus propuestas expositivas de la década de los cincuenta y sesenta, como *Parallel of Life and Art*, *House of the Future*, o *Patio & Pavilion*, han sido y son tanto o más relevantes para la crítica arquitectónica como sus escasas obras construidas o sus abundantes escritos. Sin embargo, a partir de la década de los setenta, poco se conoce de su prolífica producción expositiva.

Peter Smithson en la conferencia “The Masque and the Exhibition: Stages Towards the Real” en 1980 expresaba el importante significado que tenían las exposiciones para la conformación de su arquitectura como lugares de oportunidad para experimentar con la realidad. A partir de esta reflexión, parece lógico pensar que si hasta ese momento dichas instalaciones siempre fueron una herramienta con la que los Smithson han ofrecido algunos de sus momentos más intensos, las realizadas a partir de ese momento de reconocimiento consciente y puesta en valor de esta faceta de su trabajo, pese a su poca difusión, podrían entrañar una intensidad al menos similar a las que ya han destacado hasta el momento en los medios. Esta consideración, unida a las expectativas generadas en torno a la exposición *Christmas-Hogmanay*, tanto por ser simultánea a la elaboración de dicha conferencia, como por las ideas que se desprenden del análisis de un collage vinculado a la misma que aparece como preludio de esta tesis doctoral, ha dirigido la investigación hacia este último periodo de su arquitectura expositiva. En concreto, el estudio se centra en dos grupos que, dentro del amplio abanico de montajes expositivos realizados, destacan por poseer una cohesión intelectual propia que permitirá descubrir con mayor claridad las reflexiones que Alison y Peter Smithson ponen en escena.

En primer lugar, la Navidad, y en concreto las tradiciones populares que la celebración lleva en sí aparejadas, sirve de hilo argumental para una serie de exposiciones desarrolladas entre 1976 y 1981 por Alison Smithson, entre las que se encuentra la enigmática *Christmas-Hogmanay*. En realidad, la Navidad era un mero instrumento para transmitir su preocupación por la acuciante necesidad de reavivar la responsabilidad colectiva por la apariencia y el uso de los lugares cuando, una vez que habían sido apartados de la escena londinense, la revisión en paralelo de su trabajo les permitía depurar su pensamiento hasta llegar a la renovación de su discurso arquitectónico, el cual presentaron, una vez reinterpretado, en la monografía *The*

Shift en 1982. Así, las cuatro exposiciones analizadas aquí se revelan como diferentes estadios de una investigación acumulativa que supusieron, en ese momento crucial de renovación intelectual, una magnífica oportunidad para ensayar y encontrar una arquitectura receptiva que pudiera dar soporte a un renovado “arte de habitar”.

El segundo grupo analizado lo compone un numeroso grupo de exposiciones realizadas a continuación de las anteriores, principalmente en la década de los ochenta y noventa, vinculadas con Axel Bruchhäuser y la fábrica alemana de muebles ТЕСТА. Primero Alison, hasta su muerte en 1993, y después Peter, hasta 2003, contribuyeron y asesoraron a Bruchhäuser en sus presentaciones anuales en las ferias de mobiliario (principalmente la Feria Internacional de Colonia y la Feria del Mueble de Milán) presentando montajes que nunca fueron meramente comerciales y donde los Smithson siempre incorporaban reflexiones de gran calado intelectual. Dentro de esta estrecha colaboración, también hubo ocasión para realizar montajes mucho más reflexivos, como el presentado en la exposición *Tischleindeckdich a.s.o.*, pero sin por ello llegar a olvidar que su cliente era, aunque inusual, un fabricante de muebles. El mobiliario será siempre el epicentro de la reflexión en las exposiciones que conforman este grupo. Mobiliario que habla de arquitectura. Las exposiciones vinculadas a ТЕСТА retratan así un largo periodo que se caracteriza, más que ningún otro, por la experimentación y puesta en práctica, libre y sin condiciones, de su pensamiento. Un último periodo de madurez intelectual que constituye sin lugar a dudas su legado arquitectónico.

La tesis doctoral se estructura en cuatro grandes apartados. Arranca con un capítulo de introducción dedicado a enmarcar el tema de estudio en el que primero se analiza y contextualiza la arquitectura hecha exposición; después, se presenta la relevancia que tiene la obra expositiva en el trabajo de Alison y Peter Smithson; y finalmente se contextualiza el periodo concreto en el que se centra el estudio atendiendo tanto a su propia trayectoria como al discurso arquitectónico general.

Los dos grandes apartados de la disertación son las exposiciones de Navidad y las realizadas junto a ТЕСТА, estructurándose ambos de manera similar. Tras una breve introducción al grupo de exposiciones que se va a analizar, aparecen ampliamente documentadas cada una de las exposiciones que conforma el grupo a partir, principalmente, de la documentación inédita a la que se ha tenido acceso en los tres principales archivos dedicados a Alison and Peter Smithson: *The Alison and Peter Smithson Archive* en el Special Collections Department de la Frances Loeb Library de la Harvard Design School (Estados Unidos); *The Alison and Peter Smithson Archiv / ТЕСТА Archiv* en Lauenförde (Alemania); y *The Smithson Family Archive* en Stamford (Inglaterra). Finalmente, cada capítulo se cierra con un ensayo en el que se analizan y relacionan las diferentes reflexiones que las exposiciones ofrecen, de manera individual y en su conjunto.

El último capítulo es un breve epílogo que reúne y entrelaza todo lo anteriormente expuesto, a través de las exposiciones de Navidad y ТЕСТА, en su obra más experimental, la Hexenhaus en Bad Karlshafen.

Alison i Peter Smithson: Allò transitori i allò permanent

Dins de l'enfocament polifacètic del treball d'Alison i Peter Smithson, les exposicions en són una peça fonamental. Un mitjà poderós per a comunicar i materialitzar les idees que, al llarg de tota la seua trajectòria, els van brindar l'oportunitat d'abordar amb llibertat la construcció experimental del seu pensament.

Les seues propostes expositives de la dècada dels cinquanta i seixanta, com ara *Parallel of Life and Art*, *House of the Future*, o *Patio & Pavilion*, han sigut i són tant o més rellevants per a la crítica arquitectònica com les seues escasses obres construïdes o els seus abundants escrits. No obstant això, a partir de la dècada dels setanta, poc es coneix de la seua prolífica producció expositiva.

Peter Smithson, en la conferència "The Masque and the Exhibition: Stages Towards the Real" al 1980, expressava l'important significat que tenien les exposicions per a la conformació de la seua arquitectura com a llocs d'oportunitat per a experimentar amb la realitat. A partir d'aquesta reflexió, sembla lògic pensar que, si fins a eixe moment les dites instal·lacions sempre van ser una eina amb la qual els Smithson han ofert alguns dels seus moments més intensos, les que van realitzar a partir d'aquest moment de reconeixement conscient i posada en valor d'aquesta faceta del seu treball, tot i la poca difusió, podrien contenir una intensitat com a mínim similar a la d'aquelles que ja han destacat fins al moment en els mitjans. Aquesta consideració, unida a les expectatives generades entorn a l'exposició *Christmas-Hogmanay*, tant per ser simultània a l'elaboració de la dita conferència, com per les idees que es desprenen de l'anàlisi d'un collage vinculat a la mateixa que apareix com a preludi d'aquesta tesi doctoral, ha dirigit la investigació cap a aquest últim període de la seua arquitectura expositiva. En concret, l'estudi se centra en dos grups que, dins de l'ampli ventall de muntatges expositius realitzats, destaquen per posseir una cohesió intel·lectual pròpia que permetrà descobrir amb una major claredat les reflexions que Alison i Peter Smithson posen en escena.

En primer lloc, el Nadal, i en concret, les tradicions populars que la celebració porta aparellades, serveix de fil argumental per a una sèrie d'exposicions desenvolupades entre 1976 i 1981 per Alison Smithson, entre les quals es troba l'enigmàtica *Christmas-Hogmanay*. En realitat, el Nadal era un simple instrument per a transmetre la seua preocupació per l'apressant necessitat de revifar la responsabilitat col·lectiva per l'aparença i l'ús dels llocs quan, una vegada que havien sigut apartats de l'escena londinenca, la revisió en paral·lel del seu treball els permetia depurar el seu pensament fins arribar a la renovació del seu discurs arquitectònic, el qual van presentar, una vegada reinterpretat, en la monografia *The Shift* en 1982. Així, les quatre exposicions

analitzades aquí es revelen com a diferents estadis d'una investigació acumulativa que van suposar, en eixe moment crucial de renovació intel·lectual, una magnífica oportunitat per a assajar i trobar una arquitectura receptiva que poguera donar suport a un renovat "art d'habitar".

El segon grup analitzat el compon un nombrós grup d'exposicions realitzades a continuació de les anteriors, principalment en la dècada dels vuitanta i noranta, vinculades amb Axel Bruchhäuser i la fàbrica alemanya de mobles ТЕСТА. Primer Alison, fins a la seua mort en 1993, i després Peter, fins a 2003, van contribuir i assessorar Bruchhäuser en les seues presentacions anuals en les fires de mobiliari (principalment la Fira Internacional de Colònia i la Fira del Moble de Milà) presentant muntatges que mai no van ser merament comercials i en els quals els Smithson sempre incorporaven reflexions de gran calat intel·lectual. Dins d'aquesta estreta col·laboració, també hi va haver ocasió per a realitzar muntatges molt més reflexius, com el presentat en l'exposició *Tischleindeckdich a.s.o.*, però sense per això arribar a oblidar que el seu client era un fabricant de mobles, tot i que inusual. El mobiliari serà sempre l'epicentre de la reflexió en les exposicions que conformen aquest grup. Mobiliari que parla d'arquitectura. Les exposicions vinculades a ТЕСТА retracten així un llarg període que es caracteritza, més que cap altre, per l'experimentació i posada en pràctica, lliure i sense condicions, del seu pensament. Un últim període de maduresa intel·lectual que constitueix sense cap dubte el seu llegat arquitectònic.

La tesi doctoral s'estructura en quatre grans capítols. Arrenca amb un apartat d'introducció dedicat a emmarcar el tema d'estudi, en què primer s'analitza i contextualitza l'arquitectura feta exposició; després, es presenta la rellevància que té l'obra expositiva en el treball d'Alison i Peter Smithson; i finalment es contextualitza el període concret en què se centra l'estudi, atenent tant a la seua pròpia trajectòria com al discurs arquitectònic general.

Els dos grans capítols de la dissertació són les exposicions de Nadal i les realitzades junt amb ТЕСТА, i s'estructuren tots dos de manera similar. Després d'una breu introducció al grup d'exposicions que s'analitzarà, apareixen amplament documentades cadascuna de les exposicions que conforma el grup, a partir principalment de la documentació inèdita a la qual s'ha tingut accés en els tres principals arxius dedicats a Alison i Peter Smithson: *The Alison and Peter Smithson Archive* a l'Special Collections Department de la Frances Loeb Library de la Harvard Design School (Estats Units d'Amèrica); *The Alison and Peter Smithson Archiv / ТЕСТА Archiv* a Lauenförde (Alemanya); i *The Smithson Family Archive* a Stamford (Anglaterra). Finalment, cada capítol es tanca amb un assaig en què s'analitzen i relacionen les diferents reflexions que les exposicions ofereixen, de manera individual i en conjunt.

L'últim capítol és un breu epíleg que reuneix i entrellaça tot allò exposat anteriorment, a través de les exposicions de Nadal i ТЕСТА, en la seua obra més experimental, la Hexenhausen Bad Karlshafen.

Alison and Peter Smithson: The Transient and the Permanent

Table of contents

13 Prelude

29 Introduction

31 Architecture on Stage

53 Alison and Peter Smithson. Staging the Possible

83 Christmas Exhibitions

87 The Entrance Made Festive (1976)

95 Twenty-Four Doors to Christmas (1979)

115 Christmas & Hogmanay (1980-81)

133 Come Deck the Hall (1981)

143 Essay

157 TECTA Exhibitions

163 Cologne International Furniture Fair (1984)

169 10 Years of Stefan Wewerka in TECTA, 1975-1985 (1985)

177 The Future of Furniture - Furniture of the 4th Generation (1986)

183 Saint Jerome: The Desert – The Study (1991)

191 Modern Architecture Has Been with Us for Four Generations (1992)

197 TischleinDeckDich a.s.o. (1993)

221 Cologne International Furniture Fair (1995)

225 On the Floor Off the Floor (1998)

235 Lattice Furniture Stand (1999)

245 Popova's Chair Exhibition (2000)

249 Flying Furniture (2000)

255 Essay

281 Epilogue

299 Sources and References

307 Acknowledgements

Prelude

HISTORY • LATTICE • SPACE

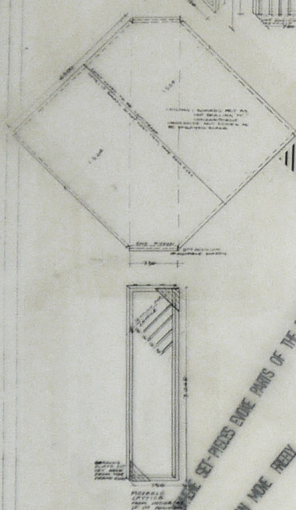
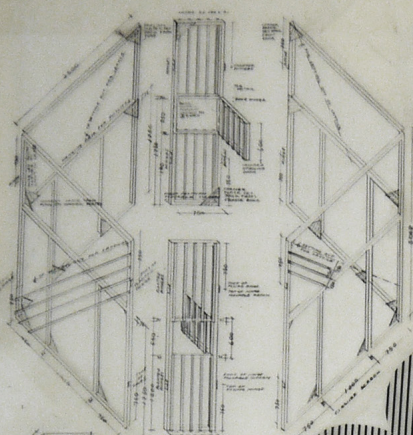
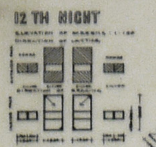
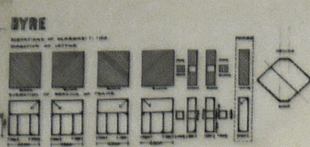
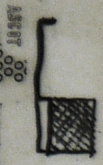
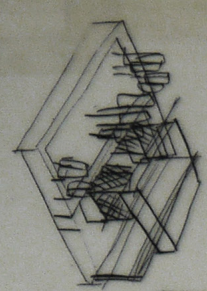
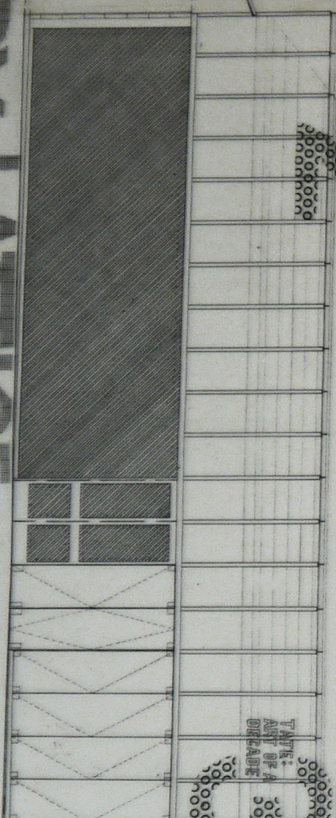
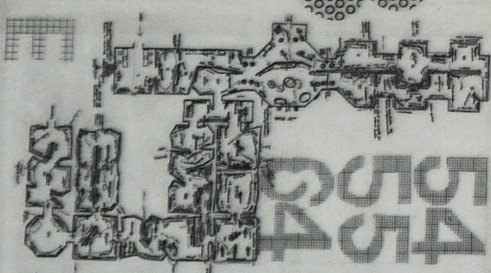

WHAT WE ARE
 HERE SPACES DOWNED BY LATTICES THAT SET FIELDS ENJOY THE PARTS OF THE FESTIVAL
 SPACES BETWEEN LATTICES WHERE PEOPLE CAN MOVE FREELY
 GENERAL TONE OF NEW FESTIVAL
 MAKE CONSISTENT & FORMAL
 LATTICE AS MEDIUM FOR WEAVING
 PER
 LAYERS OF LATTICE BECOME A SENSE OF CONSISTENCY

DEFINITION OF LATTICE: CONSISTENCY AS A QUALITY OF PLACE
 HOW TO CREATE A SENSIBILITY TOWARDS PLACES
 HOW THAT PEOPLE REALISE THEIR QUALITY OF USE MAKES THE QUALITY OF PLACE

Large stylized graphic text, possibly 'Lattice' or 'Space', rendered in a bold, striped font.



9115c
MOBILMACHUNG
-KÖLN-

REDAKTION: STEFAN WEWERKA, KÖLN, BENGT ADLERS, COPENHAGEN, KAROL BEHTKE, NEW YORK

TOWARD A NEW SENSIBILITY

WHERE CITIES ARE SEEN AS CELEBRATORY GROUNDS

STYLISHLY USED & WELL MANAGED

CHRISTMAS

1987

1987

1987

1987

1987

1987

1987

1987

1987

1987

1987

1987

1987

1987

1987

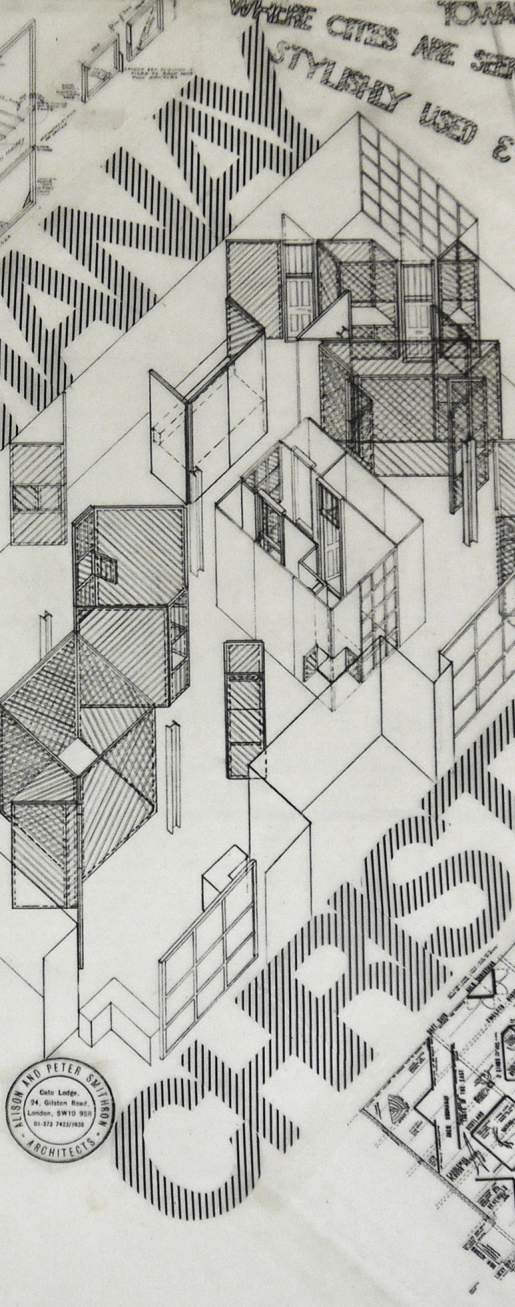

ALISON AND PETER SAVINOV
Cello Leder
24, Gilsdon Road
London, SW10 9JL
01 873 7600
ARCHITECTS

I. Collage.

After a great deal of time spent examining myriads of documents during the research for this PhD dissertation, the author was delving into yet another file at the Alison and Peter Smithson Archive at the Frances Loeb Library of the Graduate School of Design in Harvard. This folder contained several preliminary sketches for the 'Christmas-Hogmanay' exhibition and also the proofs of what seemed at first sight to be a poster for this exhibition: a large collage made of pieces of tracing paper whose most eye-catching detail was the title 'Christmas-Hogmanay'. Upon closer examination, however, it became evident that not only did this collage not belong amongst the documents related to said exhibition but was necessarily dated later. On the right of the collage are three photos of Alison Smithson taken whilst the exhibition at the Fruitmarket Gallery in Edinburgh was being either set up in December 1980 or dismantled in January 1981, judging by the fact that none of the exhibits on show whilst the exhibition was open to the public can be seen in any of the photos. In fact, Alison only appears with one exhibit: a stuffed deer with large antlers.

Since the collage dates from after the exhibition and because Alison Smithson often used graphic devices to convey ideas and concepts, it was apparently a coded message. The collage features some ideograms from the Hot Springs project she proposed for the Ascot Water Heater Exhibition stand (1955), an elevation of the crematorium at Kirkcaldy (1954), a plan of the rooms at the Tate Gallery used for the 'Painting and Sculpture of a Decade 1954-1964' exhibition held in 1964, plus several drawings and photos on different scales of the 'Christmas-Hogmanay' installation (1980-1981) – obviously the focal point of the collage. Alongside these projects by the Smithsons is what appears to be the title of a publication, *Mobilmachung* (German: mobilisation or bringing into action), whose *Redaktion* (German: editorial staff) consists of Stefan Wewerka in Cologne, Bengt Adlers in Copenhagen and Karol Behtke in New York. What might the common denominator of all this be? What message was Alison trying to convey?

When looking at the words that overlap the images in the collage, the first thing that springs to attention on the left, on account of their size and orientation, are the words 'history', 'lattice' and 'space'. Not only are these words lined up in the same direction as the drawings of the three preliminary projects but there also seems to be a certain visual association between them: 'history' with the Ascot Exhibition stand; 'lattice' with the crematorium at Kirkcaldy; and 'space' with the installation for the 'Painting and Sculpture' exhibition.

At the bottom, next to the Chi-Rho Christogram appearing in the title of the

‘Christmas-Hogmanay’ exhibition, is a text fanned out as if it were another bunch of vanishing lines from the lattice escaping from the photographs of the exhibition, a text which sums up the underlying ideas of that exhibition:

What we have:

Inside spaces contained by lattices: where set-pieces evoke parts of the festival

Spaces between lattices: where people can move freely

Celebration: Turn of the Year Festival

Ritual: Christmas & Hogmanay

Lattice as metaphor: for weather

for nature

Layers of lattice generate a sense of expectancy

Repetition of lattice: consistency as a quality of place

Aim: to create a new sensibility towards places

Hope: that people realise their quality of use makes the quality of place.

Finally, just underneath the title ‘Mobilmachung’, are three lines of text whose size and position suggest that they are the title of the entire collage:

Towards a new sensibility

Where cities are seen as celebratory grounds

Stylishly used and well maintained

History, lattice, space, layers, sensibility towards places, quality of place, cities as celebratory grounds, style of use, etc., are all basic concepts in the Smithsons’ thought but to find out what the collage really means, it is necessary to determine its date and the only element that might help in this respect is the rather unlikely word *Mobilmachung*.

Mobilmachung is a German word that appears on the collage under the word *Köln* (the German name for the city of Cologne), so the search for an answer must focus on Germany. The editorial team, consisting entirely of artists, included the German artist-architect, Stefan Wewerka. Alison and Peter Smithson had made his acquaintance during the Team 10 meetings in the 1960s and regarded him as part of the Team 10 ‘family’. In other words, Wewerka was part of the Smithsons’ life – and even more so when, after Team 10 disbanded, Wewerka contacted the Smithsons again in late 1980 and introduced them to the proprietor of the ТЕСТА furniture factory, Axel Bruchhäuser, to whom Wewerka had been the main advisor for almost a decade.

The article ‘Design - locker vom Hocker’ (‘Design - loose socks off’) published in the German magazine *Plus* in 1981 mentioned that one of Wewerka’s many ideas was to publish a book or journal offering a combination of theory, practice and life, under the significant title of *Mobilmachung* (mobilisation). The Smithsons undoubtedly agreed with this idea because their own work always featured interwoven theory and experimentation, and was also the product of the very close relationship they had shared in personal and professional realms for more than forty years. In an email to

the author of this thesis, Axel Bruchhäuser also said that ‘the idea of *Mobilmachung* means for us to realise, to make mobile, all these crazy ideas....!’¹ ‘*Mobilmachung*’ was never published as either a book or journal, however, and remained merely a possible editorial project by Wewerka.²

Because of its great importance for everyone involved, it is logical to assume that Alison made the collage in 1981, a very stimulating year for the Smithsons in all aspects: intellectually, career-wise and personally (theory, practice and life, once again). That was the year they got in touch with Axel Bruchhäuser and Stefan Wewerka, when the journal *Plus* was published, and also when they started working together.³ Axel Bruchhäuser confirmed this idea in an email to the author in which he recalls that moment: ‘At that time the Smithsons sent me (Prof. Axel Bruchhäuser, Hexenhaus) a lot of material of their work besides the silver Hogmanay poster. Possibly they sent the exhibition collage too because I remember it in my mind very vaguely.’⁴

At that time the Smithsons were in the midst of a period of reflection that coincided with preparing the first review of their work, an essay entitled *The Shift* which was finally published in 1982. The collage would therefore seem to be a pictorial summary of their ideas until that moment, which they then used as a letter of introduction and encouragement in response to the new possibility of working for the ТЕСТА furniture factory in Germany. A puzzle based mainly on their architectural legacy but which looked forward hopefully as shown by the addition of the small fragment of the ‘*Mobilmachung*’ project.

Nevertheless, it is surprising that this collage intended a visiting card for their new patron does not feature any of the Smithsons’ acclaimed buildings such as The Economist Building, Robin Hood Gardens or the Garden Building at Saint Hilda’s College and focuses on their exhibition projects including in particular a Christmas exhibition entitled ‘Christmas-Hogmanay’. Of the four projects appearing in the collage, three were exhibitions and one, the crematorium at Kirkcaldy, was never built (it was a project entered by the Smithsons for a competition they did not win). This is precisely the starting point of this PhD thesis: why were exhibitions so important to the Smithsons as vehicles for their ideas? And, in particular, what was so special about the ‘Christmas-Hogmanay’ exhibition that it was chosen the focal point of this collage?

The layout of the collage suggests that the ‘Christmas-Hogmanay’ exhibition crystallizes ideas that the Smithsons had been working on since the 1950s based on

1 Bruchhäuser, Axel (2015, April 20). [email to the author].

2 Bengt Adlers said that *Mobilmachung* might also refer to another unaccomplished project by Wewerka in which Adlers was involved, i.e. setting up an art academy in Cologne. Adlers, Bengt (2015, August 17). [email to the author].

3 They began working together with the Smithsons in December 1980, and their first meeting was planned for January 1981 according to a letter from Peter Smithson to Stefan Wewerka published in Stefan Wewerka, ed., *1972–1982. Bericht Einer Deutschen Unternehmung* (Berlin: Alexander Verlag, 1983). p.88.

4 Bruchhäuser, Axel (2015, April 20). [email to the author].

three cornerstones – history, lattice and space – illustrated by three projects by Alison Smithson, i.e. the Ascot exhibition stand, the crematorium at Kirkcaldy and the ‘Painting and Sculpture’ exhibition which are briefly examined below with a view to revealing their meaning in the collage.

The Smithsons considered their ‘Hot Springs’ proposal for the Ascot Water Heater Exhibition stand (1955) to be the first ‘pavilion’ in their architecture, ‘as distinct from the small version of the “mother” building – the “microcosm of the macrocosm” – that continued from Hustanton to Brasilia’.⁵ Pavilions are related to history. The history of modernism, the family tree from which the Smithson felt they were responsible descendants, was also the history of their pavilions, their search for an appropriate embodiment of the idyll of inhabitation, a place in harmony with nature. To achieve this, they believed, a pavilion needed a surrounding void, a fragment of an enclave. These ideas take us even further back in time to the allegory of St Jerome and his study in nature, but also to its materialisation in later projects developed by the Smithsons jointly with ТЕСТА, such as the stand they presented together at the Milan International Furniture Fair of 1991.

Alison Smithson’s proposal for the Ascot stand was a pavilion in a patio. An understanding between filled spaces and voids that was a prelude to the ‘Christmas-Hogmanay’ exhibition. By building one side of the Ascot stand against the fence, it also seemed to be a preliminary study for the design strategies employed several years later in their place of retreat in nature, their own ‘solar’ pavilion related to the modernist family tree: Upper Lawn Pavilion on the Fonthill Estate.

Alison Smithson’s proposal for the crematorium at Kirkcaldy (1954) involved the privacy needed in this type of facilities. The solution was the lattice, used here for the first time as described in the compilation of their own work *The Charged Void*: ‘screens as “veils” are first found at Kirkcaldy in a trellis that speaks of a sense of garden seclusion’. They explored lattices as a device able to tone down a person’s relationship with place, able to draw a veil over reality but also to protect the bereaved person, who would be sensitive to strong light, from any glare.

The crematorium at Kirkcaldy and the Ascot Exhibition stand are also the starting point for Alison Smithson’s article ‘Layers and Layering’ published in *Spazio e Società* in 1981. Lattices used as layers of illusion able ‘to suggest to the mind escape from the present concern, to transport the visitor’s sensibilities’ in the first instance, and lattices used as link layers in the second. In the context of the Olympia Exhibition Hall, Alison Smithson suggested the use of lattices as ‘built’ water, a metaphor for both the type of company represented by the pavilion (Ascot was a water-heater manufacturer) and the properties of the pavilion itself – which necessarily had to be linked to nature. The pavilion design once again employed a “veiling” lattice to make mysterious the place and to connect the sound and effects of water to man’s remembrance of the idyllic and the natural’.⁶ An architecture designed to offer visitors far more than just a visual experience, but neither of the two projects

5 Alison Smithson and Peter Smithson, *The Charged Void: Architecture* (New York: Monacelli Press, 2001). p.157.

6 Ibid, p.157.

were finally built.

Neither Kirkcaldy nor Ascot were built and it was to build an evocation of the possibilities inherent in our architecture language that we continued to use exhibitions to present these fleeting glimpses of another layered world.⁷

Almost thirty years after the Smithsons first toyed with lattices, yet another stage in this layering experimentation using exhibitions as a vehicle emerged: the 'Christmas-Hogmanay' exhibition featuring a series of cages confined by 'veiling' lattices that created a series of layers amongst which people could find their own place, one-direction lattices which were metaphors for the weather and nature among which the exhibits could be found.

In 1978, Peter Smithson began his article 'Some Further Layers' with the words 'If a building is to give access to its occupants [...] one way is through layering... for between the layers there is room for illusion, and for activity,' and in 1981, Alison Smithson explained that 'layering is at its most obviously poetic when the device used is a lattice.'⁸ The lattice was, therefore, a concept deeply rooted in their thinking that embraced far more than merely the physical aspect of the term and was essential in order to understand their approach to architecture, particularly from the 1970s onwards. The 'Christmas-Hogmanay' exhibition held in 1981 was the last link in the lattice research they had begun in the 1950s.

The architecture of lattices makes a place with a 'lighter touch', even one with a romantic flavour such as we find in gardens of make-believe, the outdoors that makes indoors more inviting.

In the layering of spaces – for the eye penetrates the lattices – we build another sort of place – a receptive place which the visitors are invited to decorate by being there: responsibility is returned to them for quality of use, for style of occupancy.⁹

The last project in the collage to be examined is Alison Smithson's proposal for the 'Painting and Sculpture' exhibition. An architecture within an architecture or, in other words, a new space within the old and conventional spaces of the Tate Gallery which 'explored a cranking counter-aesthetic'.¹⁰ The intention was to build a new and completely different space in which a continuum of 'angled planes of standard exhibition flats changed the space and provided carrels tailored to the families of exhibits':¹¹ spaces and lighting that catered for the requirements of each painting and sculpture whilst forming a sort of ensemble that provided a single experience for the visitor.

The brief consisted of constellations of artists to which Alison responded with a 'milky way' of works of art. The starting point was interstitial space, i.e. the void, and arose from the need to convey to visitors the links between the paintings and sculptures on show by presenting the exhibition itself as a net statement of the

7 Alison Smithson, 'Strati E Stratificazioni / Layers and Layering', *Spazio e Società*, n. 13 (1981), 96–100.

8 Ibid.

9 Alison Smithson and Smithson, *The Charged Void: Architecture*. p.471.

10 Alison Smithson and Peter Smithson, *Italian Thoughts* (Stockholm, 1993). p.20.

11 Alison Smithson and Peter Smithson, *Alison + Peter Smithson: The Shift*, ed. by David Dunster, Architectural Monographs no.7 (London: Academy Editions, 1982). p.14.

relationships governing the selected works of art. A proposal that succeeded in anonymously inhabiting the rooms in the Tate with a lightness of touch whilst creating a spatial model based on its own internal pathways in which the exhibition was enhanced by its own staging.

The 'Painting and Sculpture' exhibition is the only project in this enigmatic collage that was actually built, apart from the main feature, Christmas-Hogmanay. The impact of the 'Painting and Sculpture' exhibition was in fact far reaching on account of both the quality of the exhibits themselves and the way they were displayed, and although this exhibition was criticised by some, particularly as regards its illumination (tungsten lamps that cast shadows were chosen), there can be no doubt that its architecture offered visitors a new way of looking at art.

The winding space occupied by the 'Christmas-Hogmanay' exhibition was also a result of the links between the different exhibits which created an all-enveloping atmosphere offering visitors a refreshingly new dialogue. It seemed, at first sight, that the whole latticed setting overlapped, but the internal bays and passages created a path through the exhibition that endowed it with coherence and pace. The space defined by the architectural framework of the lattices was the visitors' guide to usage and appropriation, and the source of countless, personal interpretations. Like in the Tate Gallery in London, the architecture triggered a multi-sensorial experience in which the only leading actor was the inhabitant.

In one of the pamphlets comprising the 'Christmas-Hogmanay' exhibition catalogue entitled 'Renewal', Alison Smithson wrote: 'The intention will be fulfilled if the many separate family celebrations together renew communal confidence in the stylish use of places outside the home; by which means cities and the environment come to be creatively renewed.' This statement leads to the text that was apparently the heading of the collage: 'Towards a new sensibility where cities are seen as celebratory grounds stylishly used and well maintained.' Since the 1950s she had concentrated all her efforts on using history, lattices and space to endow inhabitants with this 'new sensibility' towards the city as 'celebratory ground'. Architecture as a multi-layered link between people and place.

Hence the collage is a summary of her ideas up until that time – but also a foretaste of her future strategies. Alison Smithson's overview of her professional career, based on four projects she directed herself, was virtually a premonition of her importance in the renewal of the Smithsons' approach to architecture that was to take place in the phase that began shortly afterwards in conjunction with Axel Bruchhäuser and ТЕСТА. Like the collage, the 'Christmas-Hogmanay' exhibition played a pivotal role in this shift in their thinking because it was the link between the architecture of the third and fourth generations of modernism.

Hence the 'Mobilmachung' period began with the layering of the stuffed deer with large antlers and the lines of the latticed screens comprising the cages, with their inhabitant, Alison Smithson, always standing out amongst them. The latticed cage depicted in the collage is the one representing the byre where the deer was exhibited.

The abstract geometry of the one-way lattice conjuring up the seasonal layers of snow and night is closely interwoven with the naturally branched structure of the deer's antlers. The lattice was beginning to change into a new frame concept: the branching lattice.

A photograph of a deer with branched antlers was exhibited in 1993 together with a collection of photos of the Hexenhaus at the Mautsch gallery in Cologne during the 'Tischleindeckdich a.s.o.' exhibition. The catalogue of that exhibition also featured the branching Christmas card designed by Alison in 1986 (a metaphor of the branches in the trees and projects at the Hexenhaus): yet another layer in the exhibition.¹² Theory, practice and life once again.

The 'branching' postcard of the reindeer entered the limelight once again in 1997. Peter Smithson sent the original postcard to Axel Bruchhäuser whilst they were busy preparing the 'On the Floor Off the Floor' exhibition at the Mautsch gallery in Cologne¹³ – an exhibition that continued the Smithsons' research into the lattice but with the addition of new variables after observing the 'branches that move and the branches that don't' in the Hexenhaus porch. The branching lattice blended in with the branches of the trees to form the interface between the user and the place, the boundary between them, whilst simultaneously fusing them together to generate a magical fairy atmosphere – the product of layering their history, their lattice and their space.

Everything is interconnected.

For me it [the collage] is like an open book of Alison and Peter Smithson and their fantastic everyday work with ALL the mentioned metaphors. [...] it shows the whole life and the whole form and artistic 'abc' or manifesto of Alison and Peter Smithson.¹⁴

12 Accordion Christmas card from the same period as the construction of Axel's Porch.

13 First exhibition layout designed by Peter Smithson for ТЕСТА after Alison's death in 1993.

14 Bruchhäuser, Axel (2015, April 16). [email to the author].



II. The stuffed deer seen through the byre cage at the 'Christmas-Hogmanay' exhibition (1980-81).

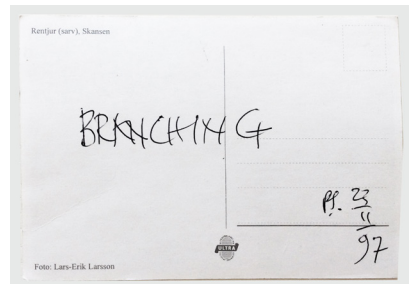

III. Photos of the Hexenhaus on show in the Mautsch gallery during the first 'Tischleindeckdich a.s.o.' exhibition in 1993. They are currently on show at the Hexenhaus.

IV. Back and front of the original postcard showing the antler concept related to the branching lattice. First exhibited at the Mautsch gallery in 1993 and sent by Peter Smithson to Axel Bruchhäuser in 1997.

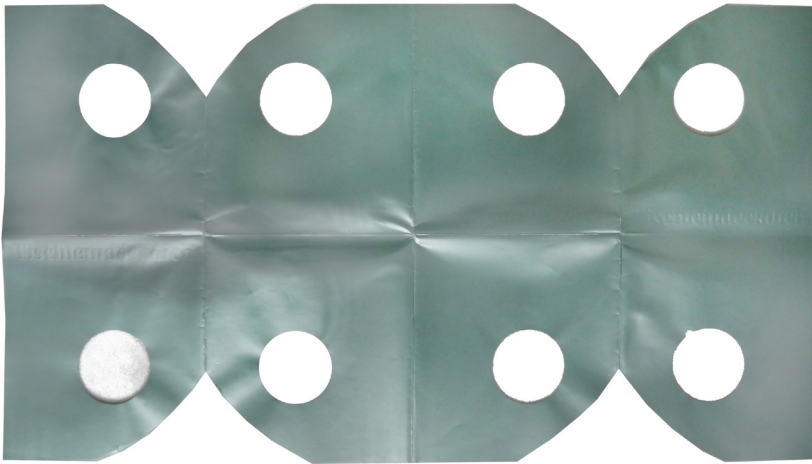

V. 'Tischleindeckdich a.s.o.' exhibition catalogue.

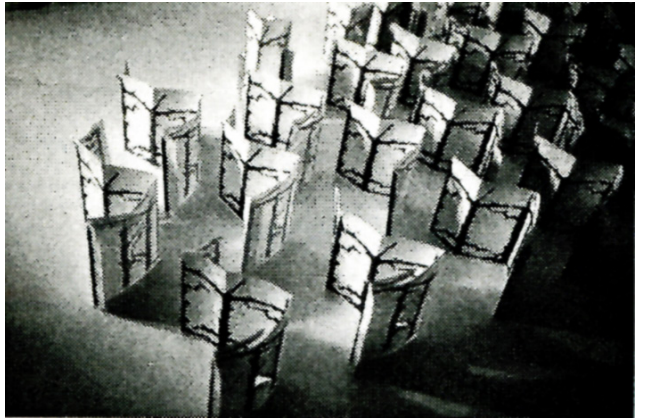

VI. Christmas card, 1986. Alison Smithson.

VII. The original branching Christmas card seen through the outer wall of Axel's Porch at the Hexenhaus.
(Photo: Axel Bruchhäuser).



Introduction

Architecture on stage

Exhibitions as mass media

Modern architecture became "modern" not as it is usually understood by using glass, steel, or reinforced concrete, but by engaging with the media: with publications, competitions, exhibitions.¹

The exhibition is not so much a vehicle for a message as a message in itself; a microcosm in which art and architecture can be experienced and expressed more freely, unfettered by real-world constraints; a scenario for radical proposals charged with reality that present the public with an architecture that is yet to come.

The evolution of art and architecture in the course of the twentieth century cannot be fully understood without taking into account the important contribution made by exhibitions, for despite their ephemeral nature, they have helped promote experimental, critical architectures. Indeed, as Beatriz Colomina pointed out, the most extreme and influential proposals in the history of modern architecture were made in the context of temporary exhibitions: Bruno Taut's Glashaus (1914), the 'De Stijl Exhibition' in Paris (1923), Le Corbusier and Pierre Jeanneret's L'Esprit Nouveau pavilion in Paris (1925), Konstantin Melnikov's USSR pavilion in Paris (1925), El Lissitzky's Soviet pavilion (1928), Mies van der Rohe's Barcelona pavilion (1929), the 'Werkbund Exhibition' in Paris (1930), the 'German Building Exhibition' in Berlin (1931), the 'Modern Architecture: International Exhibition' in New York (1932), etc. Exhibitions which were first and foremost forerunners of the avant-garde and secondly, catalysts of the spirit of their time.

All these were temporary events within the framework of a trade show, fair, biennial exhibition, museum or gallery, and because of their short lifespan and small numbers of visitors, they were only really heard of thanks to the photographs in magazines. As a result, the really significant aspect of these temporary exhibitions is the image conveyed by the media. Hence, despite their fleeting existence, exhibitions became part of modern iconography thanks to their involvement with the media. Since then, architectures have been found not only where they are actually built but also in immaterial places such as photographs, publications, exhibitions, journals, etc. 'Paradoxically, those are supposedly much more ephemeral media than the

1 This is also the main argument in her book Beatriz Colomina, *Privacy and Publicity. Modern Architecture as Mass Media* (Cambridge: The MIT Press, 1994), and also in much of her research such as the findings published in the article Beatriz Colomina, 'Mies's House: Exhibitionism and Collectionism', *2G Mies van der Rohe. Houses*, 2009, 4–21.

building and yet in many ways are much more permanent: they secure a place for an architecture in history, a historical space designed not just by the historian and critics but also by the architects themselves who deployed that media.²

One paradigmatic example is the Barcelona pavilion by Mies van der Rohe, ranked amongst the most influential buildings of the twentieth century. Paradoxically, however, not many people visited or paid any attention to this pavilion whilst it was open to the public at the 1929 Barcelona International Exposition. In fact, it was not until after another exhibition, one showcasing Mies van der Rohe's work in the Museum of Modern Art of New York in 1947, that it began to be held in high esteem. Indeed, its impact is all the more remarkable bearing in mind that until it was reconstructed in 1986 it could only be admired in photographs.³

Consequently, the real aim of all these exhibition pavilions and architectures would seem to be communication: the dissemination of their novel concepts directly to exhibition visitors and also, by engaging with the media, beyond the physical boundaries of the exhibition scenario. A dissemination based on images alone which, in Walter Benjamin's words, makes its aura – i.e. that 'special fabric of time and space' found in exhibitions – wither. Nonetheless, the loss of aura caused by the multiplication of reproductions, converts a single appearance into a mass appearance.⁴ Because the recreation of the exhibition stand is independent of the original exhibition, the former can focus on certain aspects or choose images that might originally have been overlooked by spectators, giving rise to new interpretations and meanings. As a result, the dissemination of its message via the media will necessarily be biased and slanted, 'sheer propaganda', as Colomina said, because no 'real' original is available for comparison.

In fact, from another viewpoint, architectural exhibitions themselves also make the aura of the architectonic object wither because they can only create subjective impressions, it being impossible to reproduce the fully fledged experience of a work of architecture. A building can be re-built on a 1:1 scale but not in its original setting, context, light, weather conditions, etc. In the words of Geert Bekaert, 'you can't show architecture but you can point to it'.⁵ As a result, despite not being able to showcase a real architecture, the construction of an exhibition space is in all respects the most effective way for architects to convey their 'purest' thought whilst enabling them to work in a way very similar to how they work in the real world: there is a particular place for them to work, certain materials to be used, and a user to whom their efforts are directed.

Hence, exhibitions are a vehicle and message at one and the same time. They became a very powerful tool for architecture because of the real, direct

2 Colomina, *Privacy and Publicity* p.15.

3 Colomina, 'Mies's House: Exhibitionism and Collectionism.' This article analyses in depth the relationship between Mies's houses and his exhibitions.

4 Walter Benjamin, *La obra de arte en la época de su reproductibilidad técnica* (Mexico D.F.: Itaca, 1936). Our translation.

5 Christophe Van Gerrewey, Geert Bekaert and Véronique Patteeuw, 'Architecture Can't Help Exposing Itself' In Conversation with Geert Bekaert', *OASE*, n. 88 (2012), 108–12.

communication they established thanks to the object and the subject being in the same place at the same time, a very particular and distinguishing feature of exhibitions within the spectrum of the media.

The exhibition is a message that takes place in space and also interacts with the recipient in the space they share.⁶

Space is the interface between the object and the subject. Exhibitions are a complete experiential system because they are designs in space: they need the involvement of the subject and also the spatial organisation of the items on show, i.e. the three-dimensional construction of their message.

To accurately transmit their message (a message which is essentially visual and must, therefore, be quick and easy to understand) to the recipient, exhibitions have their own, characteristic language based mainly on four cornerstones: the exhibits (content), the elements of display (frame), the sequence (layout of the plan) and the visitor (inhabitant). Other elements usually appearing together with them but not regarded as secondary elements, are light, colour, sound and typography, which intensify the mise-en-scène and breathe meaning into said cornerstones. All this adds up to a multi-faceted, open, speculative and suggestive approach that enables different readings or visions of the exhibition and allows it to communicate with different audiences at the same time.

Like every work of art, every exhibition has a purpose, i.e. to communicate with its audience and trigger an individual and personal response in the beholder.

Exhibition as architecture, architecture as exhibition

Without the exhibition there is no art (or very little). Architecture, on the other hand, already exists in the 'real world'⁷

This paradox is often voiced. Since architecture is always on display in the real world, in everyday life, it is always exhibitionist. So what is the point of architecture inside an exhibition? Tina di Carlo gives this answer: 'Exhibition as architecture, architecture as exhibition. A reflexive mirror that proposes what Foucault calls a heterotopic space.'⁸

There is a considerable difference between the architectural experience in an exhibition and the experience of architecture as a physical and spatial object in a given context. Architecture in an exhibition, i.e. a place for experiments, and in a manner similar to the process inherent in works of art, enables the conceptual structure of a message to be translated directly to the spatial structure of the exhibition.

As Eve Blau said, in the specific case of architectural exhibitions, 'the exhibition

6 Ángela García Blanco, *La Exposición, Un Medio de Comunicación*, Arte Y Estética (Madrid: Ediciones Akal, 1999), p.9.

7 Christophe Van Gerrewey, Tom Vandeputte and Véronique Patteeuw, 'The Exhibition as Productive Space', *OASE*, n. 88 (2012), 1-4.

8 Tina Di Carlo, 'Exhibitionsim', *Log*, n. 20 (2010), 151-58.

inevitably shifts the focus of concern from finished object to process, from form to idea, from the physical properties of the building to its conception and critical reception.⁹ Exhibitions in the sense of a productive space, are places for intellectual and artistic creation, hence the ‘objects on display in architectural exhibitions – drawings, prints, photographs, and sometimes models – are usually not the actual subject matter of the exhibition, but are works that in some way elucidate or represent it’ in order to make people think.¹⁰ This makes exhibitions the ideal place for new research and a fertile ground for innovation.

[...] exhibitions are indeed complex and poetic compositions, and that as the synthesis of content and design within a specific environment, exhibitions are polyvalent media that challenge established relationships between objects and ideas by placing these into new spatial and conceptual paradigms.¹¹

The architectural exhibition has the power to facilitate the architectural process by providing a real and specific context in which the architecture can interact with other contexts and, thanks to its rapid staging and interaction with visitors, fuel further research by communicating with people from all walks of life whilst simultaneously influencing the physical and social world.

‘Exhibitions with their short life span and intense population provide a valuable site for architecture research into social issues’ because, as Marianne Muller points out, ‘social ideas especially require testing, as their development often depends on experience, which can only be gained through real-life situations.’¹² Regarding exhibitions as a means of communication implied considering them as a social practice too. This made them a very powerful tool for architecture, particularly with the onset of temporary exhibitions after World War II and the increasing importance of the visitor in said communication.

An exhibition can be compared with a book insofar as the pages of a book are moved to pass by the reader’s eye, while in an exhibition the visitor moves in the process of viewing the displays. Reading a book, however, is a more restful occupation as compared to the physical efforts that are necessary for perceiving communications simultaneously with the act of walking.¹³

Visitors make an important contribution to the event. They are free to move, stand still, think about and even ignore the exhibits, all of which enables them to assimilate the exhibition in their own way. They are necessarily involved in the dynamic structure of the exhibition and, furthermore, the exhibition ‘structures its arguments interactively with the viewer and is therefore also indeterminate, fluid, and constantly changing.’¹⁴

9 Eve Blau, ‘Curating Architecture With Architecture’, *Log*, n. 20 (2010), 18–28.

10 Eve Blau, ‘Exhibiting Ideas’, *Journal of the Society of Architectural Historians*, 57 (1998), 256+366.

11 Jennifer Carter, ‘Editorial Introduction. Exhibitions as Media’, *MediaTropes*, 3 (2012), i – .

12 Marianne Mueller, ‘The Exhibition as Social Ground’, *OASE*, n. 88 (2012), 90–95.

13 Herbert Bayer, ‘Aspects of Design of Exhibitions and Museums’, *Curator: The Museum Journal*, 4 (1961), 257–88.

14 Blau, ‘Exhibiting Ideas.’

Inside the museum

Nevertheless, despite the subject's importance, it was originally regarded simply as the passive recipient of the exhibition. Exhibitions designed to convey a message first appeared in the Enlightenment as an evolution of cabinets of curiosities. Said exhibitions, the forerunners of museums, housed objects collected for merely aesthetic reasons which were displayed to the public with the scientific rigour of the incipient natural and human sciences. In earlier times it had been common for monarchs and the nobility to create private collections to showcase the beauty, uniqueness, exotic nature, etc., of certain items. Such collections were the beginning of many of Europe's great museums. In both instances, the starting point of the exhibition was always the object.

Originally, these collections were merely the product of an individual's aesthetic appreciation of an object which was selected, isolated and removed from its context. When the intention of these collections began to shift slightly from simply displaying an object to conveying a message, strategies typical of the exhibition as a means of communication began to be implemented. According to Ángela García Blanco this happened in the late nineteenth and early twentieth century, 'in the positivist era of science and its interest in taxonomy' and was symbolised by the so-called 'gallery museum' in which juxtaposed objects were exhibited.¹⁵ This was also the era of the first universal exhibitions including the 'Great Exhibition of the Works of Industry of all Nations' in London (1851) which marked the start of humanity's focus on progress and modernity and was housed in Joseph Paxton's incomparable Crystal Palace in Hyde Park. This was followed by exhibitions in Barcelona (1888), Paris (1889), Chicago (1893), Paris (1900), Chicago (1933), New York (1939), Brussels (1958), Montreal (1967) and Osaka (1970), to name but a few. All the great exhibitions, trade fairs and international fairs since then may be regarded as exhibition venues for architecture and as opportunities for architects to materialise visionary or experimental ideas on a scale of 1:1 by building the pavilions comprising them.

After World War I the critical thinking of exhibition visitors increased and they no longer wanted to dwell upon every exhibit but to focus on what really mattered. This led to a process of simplification and conceptualisation to make exhibitions more educational and easier to understand for visitors. This process entailed the involvement of the spectator and also a gradual increase in the importance of the subject in exhibitions which developed to a considerable extent after World War II and paved the way for modern museology and museography.

As a result of World War II, museums had to reorganise their collections and consider installing them in galleries once again. This led to 'an awareness of the need to make exhibitions accessible to the increasingly broad audience arising from more widespread basic education' and the development of the educational function of

15 García Blanco, p. 38.

museums too.¹⁶

Furthermore, the lack of funds available for making additions to permanent collections after World War II also led to the idea of temporary exhibitions as regular events. These exhibitions were a chance for trying out new ways of displaying exhibits, and reorganising items by creating new links between the same objects according to their different meanings. This led to the exhibition concept taking priority over the item on display, and from this point onwards it was ideas rather than objects that were showcased: a shift from exhibition to communication. This was the start of the exhibition museum as a space for meanings and a frame for information, making it an increasingly powerful vehicle for communication.

Temporary exhibitions even entered the international arena, also for reasons of prestige as a medium able to position a museum in the global limelight, and even as a vehicle for political causes or simply as a show. As a result, many museums – including none other than the MoMA in New York – are better known for their outstanding temporary exhibitions than their own enormous collections.

In the specific case of architectural exhibitions, another pivotal moment which occurred in the 1970s triggered the boom seen in such events over the last forty years.

The 1960s and 1970s saw the institutionalization of the figure of the architecturally trained historian and then, shortly afterwards, the figure of the curator. 'In addition to the architectural work exhibited, a new work is layered on top', explains Jean-Louis Cohen. A type of work that 'cogently reflects and mirrors a form of architectural practice itself' in the words of Tina di Carlo.¹⁷ With these new approaches to exhibitions, and by making the most of the exhibition's capability to be a mass medium, exhibitions became a medium for historical research and criticism in architecture too, a medium of scholarship and communication.

These new figures also prompted museums to create architectural departments (until then, only the MoMA had such a department) and led to the advent and proliferation of entities with exhibition areas devoted exclusively to architecture in both Europe and North America, including the Canadian Centre for Architecture in Montreal (founded in 1979 as a new form of cultural institution based on the concept that architecture is a public concern, which opened to the public in 1989), the Deutsches Architekturmuseum in Frankfurt (1979), the Aedes Gallery in Berlin (1980),¹⁸ the Cité de l'Architecture et du Patrimoine in Paris (1980), the Architekturmuseum in Basel (1984), the Netherlands Architecture Institute in Rotterdam (1988).

In 1979, the International Confederation of Architecture Museums (ICAM) was founded in Helsinki in response to the opening of these distinctive new venues for

16 Museums in the United Kingdom in particular deserve a special mention because they were the first to appreciate the huge potential of exhibitions as centres of learning. In the 19th century, schools and museums were already working together on the use of exhibits as teaching material through observation and experimentation. García Blanco, p.42. Our translation.

17 Di Carlo.

18 Aedes was founded in 1980 by Kristin Feireiss and Helga Retzer in Berlin-Charlottenburg as the first private architectural gallery in Europe.

the exhibition and collection of all things architectural, including museums, centres, archives, associations, etc.¹⁹

Jennifer Carter explains that all these new institutions 'have not only aimed to endow the architectural museum with a strong research mandate specifically dedicated to architectural and urban issues, they have also generated momentum by radically re-thinking the form that architectural exhibitions should take'.²⁰

Exhibiting architecture: an encounter between the object and the subject

The exhibition is but one moment in the sequence of events that comprise research, in its trajectory from an initial definition of a problem or issue to the diffusion of findings. Yet the exhibition is only very rarely the end of the journey. Nevertheless, it often constitutes a major step in the research process, because it provokes a kind of crystallization of results that themselves trigger new developments.²¹

The link between research and exhibitions is patently obvious. Architectural exhibitions create knowledge that extends far beyond what is on display, and many sowed the seed of subsequent architectures. Mies's projects for exhibitions revolutionised his work in the 1920s. The exhibition venue became his laboratory to such an extent that, as Beatriz Colomina said, Mies's architecture was born in exhibition halls.

Exhibitions are always the meeting point of the object and the subject. This intermediate nature gave rise to two ways of understanding and developing exhibitions: either by catering for the object and putting it centre stage, or by focussing on the subject for whom the exhibition is intended.

Both approaches existed throughout the twentieth century but in general, and as in the case of other types of exhibitions, until the 1960s this type of architectural research concentrated mainly on the items in the exhibition rather than the exhibits themselves. This was because until then, the purpose of architectural exhibitions had been mainly aesthetic and more priority had always been given to the object than to the subject, regardless of whether such exhibitions were events intended for a specialised audience (with mock-ups, drawings, diagrams, etc.) or were installations in which the exhibit was the architecture itself on a scale of 1:1 and thus intended for a wider audience. The turning point arose in the mid-seventies when new linguistic theories emerged, such as structuralism and semiotics, although a process of

19 For more information about its foundation, composition and aims, see <http://www.icam-web.org>.

20 Jennifer Carter, 'Architecture by Design: Exhibiting Architecture Architecturally', *Media Tropes*, 3 (2012), 28–51.

21 Jean-Louis Cohen, 'Exhibitionist Revisionism: Exposing Architectural History', *Journal of the Society of Architectural Historians*, 58 (1999), 316–25.

mediation had already begun back in the 1920s which started with the staging of the visitor as an observer.

Staging the observer

'In the 1920s, the European avant-garde reinvigorated the language of exhibitions by shifting the emphasis from staging the object to staging the observer', and this was translated into a new language and configuration of exhibition areas.²² Bauhaus and Constructivism both broke away from the traditional canons of static exhibitions, entranced by the idea of a dynamic observer who was beginning to be the leading figure in the exhibition space.

One of the leading lights in this shift in the exhibition concept, Herbert Bayer, points out that one of the first attempts to organize an exhibition according to an organic flow and sequence of exhibits was in the 'German Werkbund Exhibition' in Paris in 1930 (a collaborative exhibition design by W. Gropius, H. Bayer, M. Breuer and L. Moholy-Nagy) which featured a bridge giving a bird's-eye view of part of the show that combined with a curved wall to make the exhibition flow and exploited the idea of circulation. The main aim was to guide the visitor through the entire exhibition, not merely to provide a frame for its contents. Subsequent exhibitions, i.e. the 'Exhibition of the Building Workers' Unions', in Berlin (1931), 'The Community', also in Berlin (1936), and finally the 'Bauhaus 1919-1928' exhibition at the Museum of Modern Art in New York (1938), 'induce us to assume that by this time the concept of a planned circulation had been generally accepted as one of the fundamentals of exhibition design'.²³

Whilst designing the 'German Werkbund Exhibition' in Paris, Herbert Bayer also 'explored possibilities of extending the field of vision in order to utilize other than vertical areas and activate them with new interest. The normal field of vision becomes larger by turns of the head and body, whereby the direction of viewing and the relative position of exhibits gain new possibilities.' He successfully implemented this idea in that exhibition and subsequently echoed it in his famous *Diagram of Extended Vision* (1936) in which the focal point is a human figure – portrayed as a large eyeball sitting on a body and enveloped by angled planes – that represents the modernist desire to both expand the field of vision and situate the observer in space and time.

Furthermore, the new concepts explored in the theatre and on stage in the inter-war period also provided a new approach to the staging of exhibitions, as in the case of the proposals by Liubov Popova, Oskar Schlemmer and Walter Gropius himself which were translated into exhibitions such as Frederick Kiesler's landmark exhibition of 'New Theatre Techniques' (1924) in Vienna and triggered a radical rethink of the object-subject relationship. The most significant of them all on account of their repercussion were possibly those designed by Mies van der Rohe and Lily

22 Abbot Miller, 'From object to observer', *Eye Magazine*, 61 (Autumn 2006) <<http://www.eyemagazine.com/feature/article/from-object-to-observer>> [accessed 14 May 2015].

23 Bayer.

Reich, including the extremely well-known 'Samt & Seide Café' (1927) which deliberately confuses scene and content, and uses the exhibits to create the space they are exhibited in. 'Exhibition, then, with no other object to exhibit than the exhibition itself, exhibition of the language of the exhibition itself.'²⁴

Another aspect that all these avant-garde exhibitions had in common was the simplification of the exhibition's display equipment in comparison to its content. Bayer emphasised that 'in the exhibition of the Russian constructivists in Moscow in 1921, we noticed that a radical elimination of the unessential took place. Space and sculpture were created with elements of construction, largely linear members, in the pursuit of lightness and weightlessness with a minimum use of matter.' A revolutionary turning point came also with El Lissitzky and the 'Pressa' exhibition in Cologne (1928) which applied new constructivist ideas, the unconventional use of various materials, such as cellophane, and photomontage techniques to exhibition design.

The spatial presence of the content

A new way of understanding exhibitions emerged after World War II in which, once the formal characteristics of the new language of modernity had been assimilated, a renewed interest in the item to be exhibited appeared in force.

In Italy, outstanding works included those by Franco Albini such as the 'Flight in Italic Art' exhibition (1939) in Rome, Carlo Scarpa's 'Giovanni Bellini' exhibition (1949) in Venice, and Achille Castiglione's 'Industrial Design Section' in the X Triennial (1954) in Milan which had already begun to echo a new way of understanding exhibition before World War II, although it was only afterwards, in the 1950s, that the art of exhibiting objects was to reach its zenith. 'Perfectly lit objects, set out in front of suitably coloured backgrounds on aesthetically pleasing lightweight supports, with an air of wishing to go unnoticed yet perfectly designed down to the most minute detail'.²⁵

Mies van der Rohe became a benchmark once again in the 1940s when the MoMA mounted a retrospective exhibition of his work in 1947 entitled 'The Architecture of Mies van der Rohe'. Van der Rohe himself was responsible for selecting and laying out the contents. The novel aspect of this exhibition was that its own installation was transformed into architecture when the space in the museum rooms was redefined, thereby making the organisational system convey the idea of Mies's architecture better than any of the exhibits themselves, i.e. mock-ups, plans or photographs. As Beatriz Colomina says, 'The visitor experiences Mies's architecture, rather than a representation of it, by walking through the display and watching others move.'²⁶

The exhibited material itself becomes the means of spatial organisation, and this is apparently what made such a great impression on Charles Eames for, as he told the *Arts & Architecture* journal after his visit:

24 Joan Roig develops this idea in 'Object and Subject in Set Design Today', published in Pedro Azara, Carles Guri and Joan Roig, *Architects on Stage: Stage and Exhibition Design in the 1990s* (Barcelona: Ed. Gustavo Gili, 2000).

25 Azara, Guri and Roig. p.33.

26 Colomina, 'Mies's House: Exhibitionism and Collectionism.' In this article, Beatriz Colomina examines in depth both the exhibition and the impressions of Charles Eames.

The significant thing seems to be the way in which he [Mies] has taken documents of his architecture and furniture and used them as elements in creating a space that says, 'this is what it's all about' [...] The exhibition itself provides the smell and feel of what makes it, and Mies van der Rohe, great.²⁷

As regards the work of Charles and Ray Eames, and not just their exhibitions – i.e. Herman Miller's Graphics and Showrooms (1948-), Case Study House #8 (1949), the 'Good Design' exhibition (1950), etc. – it would seem that Mies's huge influence on the Eameses (which they always acknowledged) was 'less about buildings, more about the arrangements of objects in space. Exhibition design, layout and architecture are indistinguishable, as Mies had demonstrated [...] Eames picked up on the idea that architecture is exhibition and developed it.'²⁸

A message on stage

Whereas the exhibitions of the 1950s sought to embody their message by means of their exhibits alone, the new trend that emerged in the mid-seventies was based not so much on the exhibits themselves as on conveying a global idea within the framework of the exhibition as a whole – a logical development of the object-subject relationship. Communication came to the fore to the detriment of contents which became simply signs in this new exhibition language whose main aim was to get the message across to spectators well.

Ways of exhibiting are subordinate to ways of thinking therefore the paradigm shift in thinking that occurred in the middle of the last century – and which gave rise to postmodernist thought and, along with it, postmodernist culture and architecture – was directly echoed in exhibition concept.

In the course of the twentieth century, in the words of Jürgen Habermas, a paradigm shift took place from a philosophy of awareness or an epistemology in which what matters are the relationships between subject and object, to a philosophy of language in which what matters are the relationships between the principle and the world, i.e. a theory of meaning. Structuralist philosophy – the alma mater of postmodernist culture as Alan Colquhoun says in his essays – gained momentum in the 1970s and along with it, semiotics and semiology, based on Saussure's linguistics work, Umberto Eco's concept of *opera aperta*, the research by Roland Barthes, etc. New models of thought based on building an abstract model of relationships and transformations, and separate from the specific realities of both the object and the human subject, which were to give rise to new models when exhibiting concepts based on the relationships between the items in the exhibition.

A good example of this new approach to exhibitions was the Austria pavilion designed by Hans Hollein for the XIV Triennial of Milan held in 1968. The pavilion developed the concept of '*Il Grande Numero*' (The Great Number, the theme of the section in the Triennial where the pavilion was located) by installing a series of sensory avenues giving visitors experiences related to both 'The Great Number' and

27 Charles Eames, 'Mies van Der Rohe', *Arts & Architecture*, December (1947), 24–27.

28 Colomina, 'Mies's House: Exhibitionism and Collectionism'.

the individual, ranging from a snow storm to a supermarket, a population explosion, a corridor full of doors and frustration, or a crowded place ... The exhibition needed the action of visitors in order to prompt a response from them. That same year Hollein published his 'Alles Ist Architektur' ('Everything is Architecture') manifesto in *Bau* magazine, where he said, 'Architecture is a medium of communication. [...] Built and physical architecture, freed from the technological limitations of the past, will more intensely work with spatial qualities as well as with psychological ones.'

Venturi and Scott-Brown's proposal for the Franklin Court in Philadelphia (1972) also deserves a mention as part of this new approach. Benjamin Franklin's house was recreated in the collective memory on its original site in the form of a metal structure the same size as the house, containing items that reproduced scenes of his everyday life. 'The recreation of the site on the basis of systems which mix Pop with early manifestations of postmodernism laid the bases for a way of working.'²⁹ This approach was echoed in other exhibitions shortly afterwards too, such as the 'Signs of Life' exhibition (1976), the Pennsylvania Academy of the Fine Arts exhibition (1976), etc., all of which featured the complexity of modern architecture (ambiguities, dualities, discontinuities, fragments, etc.) and worked on recovering the significant capacity (as a sign able to produce different meanings) of architecture. The increasingly interwoven concepts of exhibition, installation and stage design created an exhibition area that was a space for communication and experience.

The putting forward of ideas rather than the exhibiting of objects, and the participative involvement of the subject in the action in which these ideas are embodied was thus the objective of this way of working clearly influenced by the new art movements that emerged in the mid-sixties.³⁰

Atmospheres

Finally, by the closing decades of the twentieth century, the spectator, object and framework had become work materials of equal importance in the construction of exhibitions.

The exhibition takes place in space for, as Henry Urbach explains, 'that space, which will soon acquire some characteristics, is something I would like to call atmosphere. [...] The atmosphere of an exhibition is, simply, its vibe.'³¹ Atmospheres are, like the fog that Urbach describes at the beginning of his article, ephemeral and immaterial and yet they have a profound impact on our senses and our perception of reality. Exhibition atmosphere can be seen but more importantly felt, inhabited and remembered.

This new approach to architectural exhibitions, by then a sort of fully fledged installation, was obviously inspired by the artistic installations that emerged in the

29 Azara, Guri and Roig. p.35.

30 Ibid, p.35.

31 Henry Urbach, 'Exhibition as Atmosphere', *Log*, n. 20 (2010), 11–17.

1970s as a criticism by the artists themselves of the elitist practices of museums. In addition, it revealed the need for a recipient public on account of exhibitions' increasing interaction, participation and involvement with the audience. These interactive installations sowed the seed for reuniting the subject and the work of art following the advent of structuralism.³²

In the end, these atmospheric exhibitions paved the way for the creation of sensory immersion spaces – due to a great extent to the development of cognitive sciences and plastic semiotics in the last twenty years – able to envelop a visitor, now as much an observer as a participant, and merge the object and subject together in a collective experience. Architects working more and more as artists invoke the space of the exhibition as a place of experimentation for architecture, 'the exhibition is no longer contained in space, but is constitutive of, and constituted by, space.'³³ Spaces that link and bring people together and even generate intimacy among strangers. Interactive immersion spaces which, in the words of the German philosopher Peter Sloterdijk, constitute truly public space.³⁴

One incipient example of this new interactive approach is possibly the 'Strada Novissima' at the Venice Biennale curated by Paolo Portoghesi in 1980. This installation brought twenty architects together along an aisle in which their architecture was represented by twenty life-size façades – for which they aimed to produce new materials – that created a meeting point inside the Arsenale galleries. A singular and 'highly theatrical display, which produced a new and very impressive type of exhibition space'.³⁵ Nevertheless, 'part of the strength of this exhibition lay precisely in the fact that its theoretical discourse was in perfect adequacy with the unusual form of its display,'³⁶ mirroring concepts of the exhibition as street and the street as exhibition.

As Rem Koolhaas said, the 'Strada Novissima' demonstrated above all 'that architecture was no longer a substance but an illusion'.³⁷

This new approach to exhibiting architecture sought increasingly to stimulate and interact with visitors on the basis of their own physical experience, enabling them to become more and more interested in spatial issues, i.e. to develop the spectator's awareness of architecture: the medium of architecture heightens the transmission of ideas. This is the case of Peter Eisenman's 'Cities of Artificial Excavation' at the CCA

32 This subject is examined at length in Alessandra Mariani, 'Pratiques Interactives et Immersives ; Pratiques Spatiales Critiques. La Réalité Augmentée de L'espace D'exposition', *MediaTropes*, 3 (2012), 52–81.

33 Di Carlo.

34 Peter Sloterdijk, *Atmospheric Politics*, in: Bruno Latour and Peter Weibel (ed.), 'Making Things Public: atmospheres of democracy', 2005, p. 946.

35 Léa-Catherine Szacka, 'The 1980 Architecture Biennale The Street as a Spatial and Representational Curating Device', *OASE*, n. 88 (2012), 14–25.

36 Frédéric Migayrou 'Destin du Postmoderne. La Strada Novissima' reproduced in: Szacka, 'The 1980 Architecture Biennale The Street as a Spatial and Representational Curating Device'.

37 Léa-Catherine Szacka, 'Léa-Catherine Szacka in Conversation with Rem Koolhaas and Stefano de Martino', *OASE*, n. 94 (2015).

in Montreal (1994) and Daniel Libeskind's 'Beyond the Wall, 26.36°' at the NAI in Rotterdam (1997) in which their work was not so much exhibited as performed like an installation. In the first instance, Eisenman questioned, through an installation that was a work of architecture in its own right, the concept of 'site' (which he considered to be a locus of possibilities), whilst revealing the richness and complexity of his design process. Libeskind, on the other hand, presented visitors with a maze of leaning walls 'which imparted a physical impact on their experience of space and helped them to understand the conceptual approach of the architect as expressed in over forty models and one hundred drawings.'³⁸ The atmosphere is a vehicle for understanding the exhibits, the framework enabling different, complementary languages to coexist, merge together and complement each other.

An interesting trend which has emerged in the exhibitions staged by architects in recent years is the gradual blurring of the boundary between art installation and architectural intervention. Finally, the architectural exhibition gives visitors such a spatial and sensory immersion that 'it could be said that the exhibition exhibits nothing, represents nothing, is the abstraction of nothing, not even of itself, but is itself a reality, a factual presence, like any object that might be exhibited or any idea that might be transmitted.'³⁹

The exhibitions by Elizabeth Dieller and Ricardo Scofidio form part of this novel approach. Their extensive background of investigating architecture through installations includes their 'Parasite' exhibition at the MoMA (1989) and the memorable 'Blur Building' exhibition pavilion at the Swiss Expo (2002). This installation/exhibition/pavilion/performance hybrid was perceived merely as an architecture of atmosphere, a surprising 'fog-mass resulting from natural and manmade forces'. As they said, 'upon entering Blur visual and acoustic references are erased. [...] In this exposition pavilion there is nothing to see but our dependence on vision itself.'⁴⁰

Also deserving a special mention is the artist Olafur Eliasson who, despite not being an architect, produced artistic installations and work which are closely related to architecture and particularly to atmospheric exhibitions. His creation 'The Weather Project' (2003) for the Turbine Hall in the Tate Modern manipulated the perception of physical and sensory surroundings hugely by installing a massive sun in the hall that even eliminated the perception of colour. His aim was to make visitors aware of the power of the weather despite mankind's many efforts to tame it. Simple but striking. Alessandra Mariani points out that 'The Weather Project repositions the onlooker "inside the painting" just as the cyclorama did in the eighteenth century'.⁴¹

38 Kristin Feireiss 'It's not about art' in Kristin Feireiss, ed., *The Art of Architecture Exhibitions* (Rotterdam: NAI Publishers, 2001), p.11.

39 Azara, Guri and Roig. p.37.

40 Dieller & Scofidio 'Blur Building' <<http://www.dsry.com/projects/blur-building>> [accessed 18 June 2015].

41 Mariani.

As mentioned at the beginning of this chapter, architecture lost its 'aura', i.e. its ability to create an atmosphere, when it was introduced into museum galleries in the late nineteenth century in the form of either display equipment or actual exhibits. In the late twentieth and early twenty-first century, however, architecture regained its most experimental dimension with the introduction of areas of sensory immersion into museum rooms. These areas, a vehicle for the conceptual and the sensory, made it possible to materialise the 'dream' of building 'real' architecture in this context too, thereby making them a real place for production and discourse.

When content is rendered as form in such a way that it communicates didactic and perceptual facets of information spatially and at once - then the architectural exhibition as media will have achieved its greatest potential.⁴²

42 Carter, 'Architecture by Design: Exhibiting Architecture Architecturally'.

Twentieth-century exhibitions

1850

· *The Great Exhibition*. London, 1851

1870

· *The First Impressionist Exhibition*. Claude Monet, Edgar Degas, Pierre-Auguste Renoir, Camille Pissarro and others. 35 Boulevard des Capucines, Paris, 1874

1890

· *Secession Building*. Joseph Maria Olbrich. Viena, 1897

1910

· *Glashaus*. Bruno Taut. German Werkbund Exhibition, Cologne, 1914

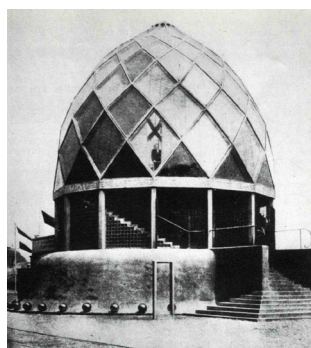

1920

· *OBMOKhU Second Spring Exhibition (Society of Young Artists)*. Karl Iogansson, Konstantin Medunetzky, Georgii and Vladimir Stenberg, Aleksei Gan, Aleksandr Ródchenko, Varvara Stepánova, and others. Mikhailova Salon, Moscow, 1921

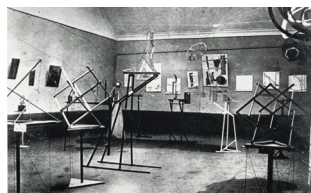

· *5x5=25: Russian Avant-Garde Exhibition*. Liubov Popova, Aleksandr Ródchenko, Varvara Stepánova, Alexander Vesnin, Aleksandra Ekster. Institute for Artistic Culture, Moscow, 1921

· *De Stijl*. Theo van Doesburg, Cornelis Van Eesteren, Vilmos Huszár, Willem van Leusden, Jacobus Johannes Pieter Oud, Gerrit Rietveld, Mies van der Rohe and Jan Wils. L'Effort Moderne, Paris, 1923



· *Exhibition of New Theatre Techniques*. Friedrich Kiesler. Viena, 1924

· *City of Space*. Friedrich Kiesler. International Exhibition of Modern Decorative and Industrial Arts, Paris, 1925

· *L'Esprit Nouveau Pavilion*. Le Corbusier. International Exhibition of Modern Decorative and Industrial Arts, Paris, 1925



· *USSR Pavilion*. Konstantín Mélnikov. International Exhibition of Modern Decorative and Industrial Arts, Paris, 1925



· *Weissenhofsiedlungen*. Jacobus Johannes Pieter Oud, Mart Stam, Le Corbusier, Peter Behrens, Walter Gropius, Ludwig Hilberseimer, Mies van der Rohe, Hans Scharoun, Bruno Taut and others. Stuttgart, 1927

· *Living Room in Mirror Glass*. Mies van Der Rohe and Lily Reich. Werkbund exhibition, Stuttgart, 1927

· *The Samt & Seide café*. Mies van der Rohe and Lily Reich. Women's Fashion Exhibition, Berlin, 1927

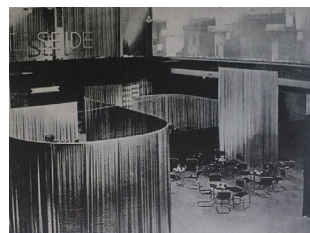

· *Nestlé's Demountable Pavilion*. Le Corbusier and Pierre Jeanneret. Paris, 1928



· *Pavilion of City of Brno*. Bohuslav Fuchs. Brno Exhibition, Brno, 1928

· *Soviet Pavilion*. El Lissitzky. 'Pressa' Exhibition, Cologne, 1928

· *Barcelona Pavilion*. Mies van der Rohe. Barcelona International Exhibition, Barcelona, 1929



· *Equipment for the Home*. Le Corbusier, Pierre Jeanneret and Charlotte Perriand. Salon d'Automne, Paris, 1929



1930

· *'Le Paradis' Restaurant and The Boat Hall*. Erik Gunnar Asplund. The Stockholm Exhibition, Stockholm, 1930



· *Communal and Individual Rooms for an Apartment Building*. Walter Gropius and Marcel Breuer. German Werkbund Exhibition, Paris, 1930

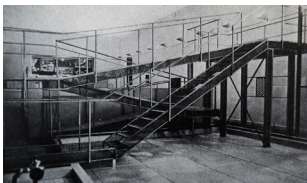

· *Room 5*. Herbert Bayer. German Werkbund Exhibition. Salon of the Société des Artistes Décorateurs, Paris, 1930



· *Frank Lloyd Wright Exhibition of Architecture*. Stedelijk Museum, Amsterdam, 1931

· *Apartment House Communal Rooms*. Walter Gropius. German Building Exhibition, Berlin, 1931

· *Bedroom*. Lily Reich. German Building Exhibition, Berlin, 1931

· *House For a Childless Couple*. Mies Van der Rohe. German Building Exhibition, Berlin, 1931



· *Modern Architecture: International Exhibition*. Philip Johnson and Henry-Russell Hitchcock. The Museum of Modern Art, New York, 1932



· *Exhibition Cupola Metz & Co*. Gerrit Rietveld. Department store Metz & Co, Amsterdam, 1933



· *The Crystal House; The Dymaxion Car no.3*. Buckminster Fuller and George Fred Keck. Chicago World's Fair, Chicago, 1934

· *Non-ferrous Metals Exhibit*. Walter Gropius and Joost Schmidt. German People-German Labor Exhibition, Berlin, 1934

· *Stand for Olivetti*. Luigi Figini and Gino Pollini. Milan Fair, Milan 1935

· *Young Man's Home: The study*. Le Corbusier, Pierre Jeanneret, Charlotte Perriand. International Exhibition, Brussels, 1935

· *The Swiss Pavilion*. Max Bill. Sixth Triennial, Milan, 1936

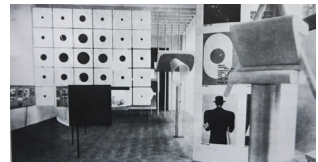

· *The Swedish Pavilion*. Sven Ivar Lind. International Exhibition, Paris, 1937

· *Exposition Internationale du Surréalisme*. Salvador Dalí, René Magritte, Joan Miró, Max Ernst, Alberto Giacometti, Man Ray and others. Beaux-Arts Gallery, Paris, 1938

· *Finnish Pavilion*. Alvar Aalto. World's Fair, New York, 1939

· *Flight in Italic Art Exhibition*. Franco Albini. Rome, 1939

1940

· *Sixteen Miles of String*. Marcel Duchamp. The First Papers of Surrealism exhibition, New York, 1942

· *New Furniture Designed by Charles Eames*. The Museum of Modern Art, New York, 1946

· *The Architecture of Mies van der Rohe*. Mies Van der Rohe. The Museum of Modern Art, New York, 1947



· *Blood Flames*. Frederick Kiesler. Hugo Gallery, New York, 1947

· *Giovanni Bellini*. Carlo Scarpa. Palazzo Ducale, Venice, 1949

1950

· *Jackson Pollock: Ollii e guazzi*. Jackson Pollock. Museo Correr, Venice, 1950

· *Herman Miller Furniture Company Showroom*. Charles and Ray Eames. Los Angeles, 1950



· *The New Landscape*. Gyorgy Kepes. Hayden Gallery, MIT, Cambridge, 1951

· *Architecture in Movement*. *Architettura, Misura dell'Uomo*. Ernesto Rogers, Vittorio Gregotti and Giotto Stopinno. Eleventh Triennial, Milan, 1951

· *Growth and Form*. Richard Hamilton. ICA, London, 1951



· *Parallel of Life and Art*. Alison and Peter Smithson, Nigel Henderson, Eduardo Paolozzi and Ronald Jenkins. Institute of Contemporary Arts, London, 1953



· *Industrial Design Section*. Achille Castiglione. Tenth Triennial, Milan, 1954

· *Man, Machine and Motion*. Richard Hamilton. ICA, London, 1955

· *The City by Day, The City by Night*. Alison and Peter Smithson. (MARS Group). Other participants: Edwin Maxwell Fry, Jane Drew, Eduardo Paolozzi. Turn Again Exhibition, Royal Exchange, London, 1955

· *Modern Art in the United States: A Selection from the Collections of The Museum of Modern Art, New York*. The Tate Gallery, London, 1956

· *House of the Future*. Alison Smithson. Daily Mail Ideal Home Exhibition, Olympia, London, 1956

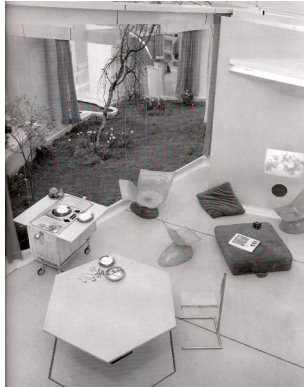

· *Patio & Pavilion*. Alison and Peter Smithson, Nigel Henderson and Eduardo Paolozzi. This is Tomorrow exhibition, Whitechapel Art Gallery, London, 1956



· *An Exhibit*. Richard Hamilton. Institute of Contemporary Arts, London, 1957



· *Spanish Pavilion*. José Antonio Corrales and Ramón Vázquez Molezún.

· *Philips Pavilion*. Le Corbusier. *German Pavilion*. Egon Eiermann and others. International Exhibition, Brussels, 1958

· *Jackson Pollock Exhibition*. Whitechapel Gallery, London, 1958

· *The New American Painting*. Tate Gallery, London, 1959

· *Glimpses of the USA*. Charles and Ray Eames. American National Exhibition in Moscow, 1959

1960

· *Mathematica: A World of Numbers... and Beyond*. Charles and Ray Eames. California Museum of Science and Industry, Los Angeles, 1961



· *The Living City*. Archigram. Institute of Contemporary Arts, London, 1963

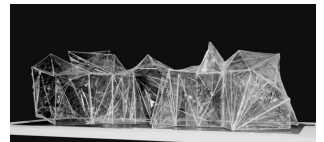

· *Painting and Sculpture of a Decade: 1954-1964*. Alison Smithson. Tate Gallery, London, 1964



· *IBM Pavilion*. Charles Eames and Eero Saarinen. New York World's Fair, New York, 1964-65

· *Architecture Without Architects*. Bernard Rudofsky. The Museum of Modern Art, New York, 1964



· *Primary Structures: Younger American and British Sculptors*. Carl Andre, Dan Flavin, Donald Judd, Sol LeWitt, Walter De Maria, Robert Morris. Jewish Museum, New York, 1966

· *Living 1990*. Archigram. Tomorrow's Home Exhibition, Harrods, London, 1967



· *Austrian Pavilion*. Hans Hollein. Fourteenth Triennial, Milan, 1968



· *Wedding in the City*. Alison Smithson. The Greater Number, Fourteenth Triennial, Milan, 1968



· *James Stirling: Three University Buildings*. James Stirling. The Museum of Modern Art, New York, 1968

· *The New York Five*. Peter Eisenman, Michael Graves, Charles Gwathmey, John Hejduk, Richard Meier. The Museum of Modern Art, New York, 1969

1970

· *Franklin Court*. Robert Venturi, Denise Scott Brown. Independence National Historical Park, Philadelphia, 1972-1976



· *Documenta 5*. Harald Szeemann. Neue Galerie, Kassel, 1972

· *The Architectural Association 125th Anniversary Exhibition*. Archigram. Institute of Contemporary Arts, London, 1973

· *Cheer-up It's Archigram!* Archigram. Institute of Contemporary Arts, London, 1973



· *Architettura Razionale*. Aldo Rossi. Lo Spazio Abitabile, Fifteenth Triennial, Milan, 1973

· *Exhibition of Architectural Graphics by Natalini, Hollein, Himmelblau*. Adolfo Natalini, Hans Hollein, Coop Himmelbau. Institute of Contemporary Arts, London, 1973

· *Architecture Without Architects*. Bernard Rudofsky. Institute of Contemporary Arts, London, 1974

· *A Line of Trees... A Steel Structure*. Alison and Peter Smithson. Art Net Gallery, London, 1975

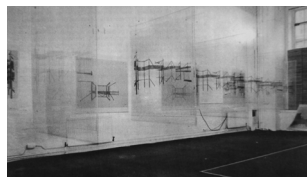

· *The World of Franklin & Jefferson*. Charles and Ray Eames. Touring Exhibition, 1975-1977



· *Sticks and Stones*. Alison Smithson. Europa/America. Architettura Urbana/Alternative Suburbana. Venice Biennial, 1976



· *Signs of Life: Symbols in the American City*. Robert Venturi, Denise Scott Brown. Renwick Gallery, National Collection of Fine Arts, Washington, 1976



· *Dan Graham: Performance and Exhibition*. Institute of Contemporary Arts, London, 1976

· *The Architecture of the École des Beaux Arts*. Arthur Drexler. The Museum of Modern Art, New York,

1977

· *Twenty-Four Doors to Christmas*. Alison Smithson. Kettle's Yard, Cambridge, 1979



· *Teatro del Mondo*. Aldo Rossi. Venice Biennial, 1979



1980

· *Strada Novissima*. Frank O. Gehry, Rem Koolhaas, Arata Isozaki, Robert Venturi, and others. Director: Paolo PORTOGHESI. The Presence of the Past, Venice Biennial, Venice, 1980

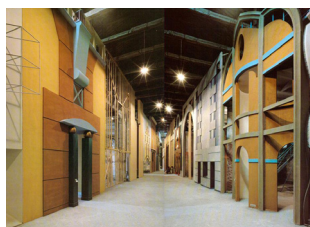

· *Christmas & Hogmanay*. Alison Smithson. Fruitmarket Gallery, Edinburgh, 1980



· *A New Spirit in Painting*. Royal Academy, London, 1981

· *Architettura/Idea*. Aldo Rossi. Sixteenth Triennial, Milan, 1982

· *Ten New Buildings*. Mario Botta, Henri Cirian, Lluís Clotet & Oscar Tusquets, Frank Gehry, Hans Hollein, Arata Isozaki, Josef Paul Kleihues, Charles Moore, Alvaro Siza, James Stirling. Art and Architecture Series, Institute of Contemporary Arts, London, 1982

· *Aldo Rossi: Projects and Drawings*. Aldo Rossi. Institute of Contemporary Arts, London, 1983

· *Model Futures: Contemporary British Architecture*. Institute of Contemporary Arts, London, 1983

· *Cellular Maze: Richard Hamilton & Rita Donagh*. Institute of Contemporary Arts, London, 1984

· *Les Immatériaux*. Jean-François Lyotard and Thierry Chaput. Centre Georges Pompidou, Paris, 1985

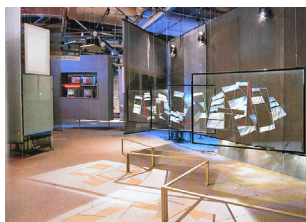

· *La Casa Palestra*. OMA (Office for Metropolitan Architecture), Seventeenth Triennial, Milan, 1986

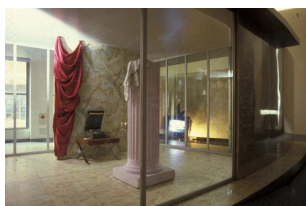

· *International Building Exhibition IBA1987*. Peter Eisenman, Vittorio Gregotti, Herman Hertzberger, Hans Hollein, Arata Isozaki, Rob Krier, Aldo Rossi, James Stirling and others. Berlin, 1987

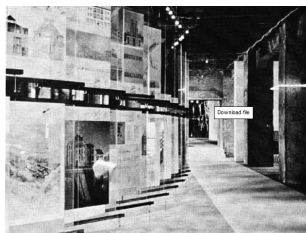

· *Three Projects*. James Stirling. Tate Gallery, London, 1987

· *L'aventure Le Corbusier, 1887-1965*. Centre Georges Pompidou, Paris, 1987

· *The Christmas Tree*. Bill Woodrow. Tate Gallery, London, 1988

· *Deconstructivist Architecture*. Mark Wigley and Philip Johnson. MoMA The Museum of Modern Art, New York, 1988

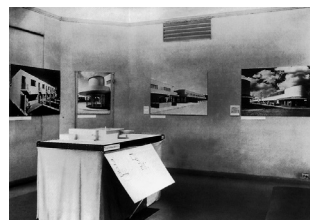

· *Metropolis: New British Architecture and the City*. Institute of Contemporary Arts, London, 1988

· *OMA - The First Decade*. OMA (Office for Metropolitan Architecture). Boijmans van Beuningen Museum, Rotterdam, 1989



· *Parasite Exhibition*. Elizabeth Diller and Ricardo Scofidio. MoMA The Museum of Modern Art, New York, 1989

1990

· *The Independent Group: Postwar Britain And The Aesthetics Of Plenty*. Magda Cordell, Richard Hamilton, Nigel Henderson, John McHale, Eduardo Paolozzi, Alison and Peter Smithson and William Turnbull. Institute of Contemporary Arts, London, 1990

· *Nouvel: Jean Nouvel, Emmanuel Cattani and Associates*. Institute of Contemporary Arts, London, 1992

· **TischleinDeckDich a.s.o.** Alison Smithson. Mautsch Gallery, Cologne and Aedes Gallery, Berlin, 1993



· *Exhibition on the Work of Venturi, Scott-Brown and Associates.* Robert Venturi and Denise Scott Brown. Institute of Contemporary Art, University of Pennsylvania, Philadelphia, 1993

· *Cities of Artificial Excavation: The Work of Peter Eisenman, 1978-1988.* Peter Eisenman. Canadian Centre for Architecture, Montreal, 1994



· *Exhibition of drinking glasses.* Christopher Alexander. Royal Dutch Glassworks Museum, Leerdam, Holland, 1997



· *Beyond the Wall 26.36°.* Daniel Libeskind. Netherlands Architecture Institute, Rotterdam, 1997

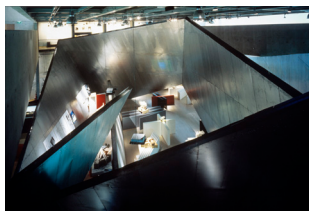

· **On the Floor Off The Floor.** Peter Smithson. Mautsch Gallery, Cologne, 1998



· *Unfolding.* Daniel Libeskind. Dutch Architecture Museum, Rotterdam, 1998

· *OMA Rem Koolhaas: Living.* Institute of Contemporary Arts, London, 1999

· *Zaha Hadid.* Institute of Contemporary Arts, London, 2000

· *Blur Building.* Elizabeth Diller and Ricardo Scofidio. International Exhibition, Switzerland, 2002



· *The Weather Project.* Olafur Eliasson. The Tate Gallery, London, 2003

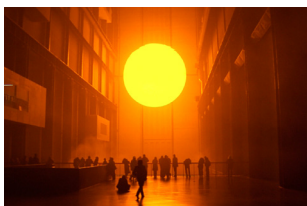

Alison & Peter Smithson. Staging the Possible

To fix a question,
to identify a problem...
and carry it a long time.
Day after day.
The conclusions are temporary.
Are a way to store material.⁴³

The above quotation taken from 'The Answer', an article by Enric Miralles about Alison and Peter Smithson published in *OASE* in 1999, sums up the strategy they applied to their work perfectly. A life dedicated to architecture, thinking and research, to asking questions and finding answers, applying poetry, coherence and rigour, over and over, time and time again, regardless of the scale or basis of their research: a diagram, a project, a building, a piece of furniture, a book or an exhibition. Alison admitted this when *The Sunday Times Magazine* interviewed her in 1987: 'We did nothing but work all the time. Architecture takes up all our time. It is not only our work, but the spur for all our emotions'.⁴⁴

An uninterrupted flow of creations and re-creations spread out over time and always carried out in parallel – between Alison and Peter, between their private life and public life, between writing and building – and always amazingly consistent. This thoughtful and critical attitude to all spheres of their life made the Smithsons profoundly aware of the need to take a stance: hence their commitment to architecture began at the same time as their professional career.

In 1950, just six months after Alison graduated from the University of Durham, the Smithsons won a prestigious competition to build Hunstanton School which enabled them to set up their own practice. The 1950s turned out to be a time of change and hope – and uncertainty too. Two world wars had elapsed and it was now morally necessary to work in keeping with the new cultural circumstances that had emerged in the aftermath of World War II for, as the Smithsons said, 'it is necessary to create an architecture of reality'.⁴⁵ This conviction and sense of responsibility led to their involvement and leading role in contemporary groups of artistic research and discussion: the Independent Group, the MARS group (the British arm of the International Congresses of Modern Architecture, CIAM) and subsequently Team 10.

In the spring of 1952, the Institute of Contemporary Arts in London held what is regarded as the first meeting of the Independent Group. A free association of young artists, architects, writers and critics committed to their times and who shared both a desire to play an active role in the cultural scene of post-war Britain and a fascination for the impending consumer culture, questioning the prevailing aesthetic culture.

In 1951 the Smithsons attended eighth CIAM congress in Hoddesdon and in 1953 they became young members of the British group MARS. That same year they took

43 Enric Miralles 'The Answer', in Dirk van den Heuvel, ed., *Rearrangements: A Smithsons Celebration*, *OASE* n°51 (1999). p.18.

44 Marco Vidotto, *Alison + Peter Smithson. Obras y Proyectos* (Barcelona: Ed. Gustavo Gili, 1997).p.18.

45 Statement made in the *Architectural Review* in 1954 and reproduced in Vidotto, *Alison + Peter Smithson. Obras y Proyectos*.

part in the ninth CIAM congress at Aix-en-Provence with their provocative proposal 'Urban Re-identification Grille' which subverted CIAM canons by replacing the four categories of the functional city, i.e. dwelling, work, transportation and recreation, with a grid based on 'human associations', i.e. house, street, district and city. This critical stance adopted by the new generation entering the congresses triggered a crisis in the CIAM which ended with them being disbanded and the advent of Team 10, in which the Smithsons always played a key role. Consequently, by taking part first as members of the MARS group (1953-1956) in the CIAM's and then in Team 10 (1956-1981), they actively intervened in the construction of a new architectonic culture following World War II.

The Smithsons did not, in fact, have many opportunities to build, but even so the impact of their work was quite considerable, due to a great extent to the intensity of their contributions in both teaching and the media in the form of books, essays, lectures and particularly exhibitions.

As part of their voluntary, ethical commitment to architecture, the Smithsons became actively involved in the classroom, where they interwove teaching, reflection and experiment into their courses, seminars and lectures. Peter Smithson started teaching at the Central School of Art and Crafts in London, where he met Paolozzi, and in 1955 he began teaching at the renowned Architectural Association. Subsequently, in the 1980s, whilst Peter was teaching at Bath, Alison began to give seminars abroad – Delft, Munich, Barcelona – where, as Max Risselada said, 'she introduced a number of themes into discussion, some of which were taken in retrospect from existing work while others were newly raised'.⁴⁶ Meanwhile, Peter Smithson attended the International Laboratory of Architecture & Urban Design (ILA&UD) workshop every year since it was established by Giancarlo De Carlo in Urbino in 1974, and from 1977 onwards, he gave a lecture there each year in which he shared the concerns he gleaned from his experiences and daily collaborative work. In this exchange, the Smithsons experienced 'a period apparently full of discoveries and of personal change'.⁴⁷ These reflections were published regularly as articles in the ILA&UD's yearbooks, and some were compiled in 1993 and published together as a book entitled *Italian Thoughts*.

The Smithsons' writings – books, essays, articles, manifestos, opinion columns, sensibility primers, novels, etc. – also played an important role in their work, either as an introduction to ideas they had not yet managed to materialise or as a way of reviewing and appreciating what they had built, and providing feedback about their ideas. This is revealed in the opening lines of *Without Rhetoric*:

We write to make ourselves see what we have got in the inescapable present... to give another interpretation of the same ruins... to show a glimpse of another aesthetic.⁴⁸

46 Max Risselada, ed., *Alison and Peter Smithson: A Critical Anthology* (Barcelona: Ediciones Polígrafa, 2011). p.28.

47 Alison Smithson and Peter Smithson, *Italian Thoughts* (Stockholm, 1993). p.6.

48 Alison Smithson and Peter Smithson, *Without Rhetoric: An Architectural Aesthetic, 1955-1972* (London: Latimer New Dimensions, 1973). p.1.

As Simon Smithson said, Alison and Peter Smithson were ‘two architects who designed and wrote – in parallel. Reading and writing (and I [he] specifically choose to put these activities in that order) were consuming activities for both my [his] parents’.⁴⁹ Their love of reading since childhood had given them a vast culture, particularly in the realm of architecture (of course) which is reflected in the thinking behind their projects and writings. Their broad knowledge of architecture enabled them to masterfully sum up the architecture of their predecessors in drawings and short texts, first in 1965 in the special edition of the journal *Architectural Design*, *The Heroic Period of Modern Architecture*, and subsequently in a similar fashion in their book *The 1930s* in 1985. Indeed, as Mark Wigley pointed out in his review of *The Charged Void*, ‘these extraordinarily efficient summaries of whole generations of design acted as the model for a series of equally efficient summaries of the development of their own work’.⁵⁰ *Without Rhetoric – An Architectural Aesthetic* addresses their thoughts from the 1955-1972 period, *Ordinariness & Light* compiles articles from 1952 to 1960, *The Shift* covers their work over three decades, and the paradigmatic example of a summary reviewed by Wigley, *The Charged Void*, is the tome that finally compiles all their work from 1947 up to Alison’s death in 1993, ‘providing the raw material for an interpretation’.⁵¹

In a way, the Smithsons’ writings teach us about their architectural ideas and also about what can be learnt from architecture itself, but these are unstructured, unfettered lessons that readers can interpret in their own way – just like the Smithsons’ own thinking and vision of architecture. In *Italian Thoughts*, they said: ‘we were interested in training the architect’s mind, in a kind of free-fall ordering; an ordering with infinite variations; without imposed boundaries; capable of recognising unfolding orders’.⁵² This statement refers to their thought-provoking presentation at the ninth CIAM in Aix-en-Provence and was a clear indication of the incipient new direction they were already contemplating: not only did they submit a novel proposal but their attitude was also radically different from that of the previous generation taking part in the CIAM. Their ultimate aim was to open up their minds to possibilities and therefore, as Max Risselada said, their concept of ‘the space-between’ was to be found not only in their projects but also in their writings: ‘There is always a distance between text and building – a space that is open to one’s own interpretation. This is one of the reasons the Smithsons did not create a “school” [...] One was forced to go one’s way’.⁵³

Alison Smithson’s famous aphorism ‘For us, a book is a small building’⁵⁴ is yet another example of how the activities of writing and building merge together as part of the same thought, and were different battles in the same war. The Smithsons were both

49 Simon Smithson, ‘Foreword: On Editing and Pruning’ in Risselada. p.15.

50 Mark Wigley, ‘Alison and Peter Smithson – The Architects of the Void’ in Risselada. p.417.

51 Peter Smithson and Hans-Ulrich Obrist, *Smithson Time: A Dialogue* (Cologne: König, 2004). p.12.

52 Smithson and Smithson, *Italian Thoughts*. p.68.

53 Max Risselada ‘The Space Between’ in Heuvel. p.53.

54 Alison Smithson and Peter Smithson, *The Charged Void: Urbanism* (New York: Monacelli Press, 2005). p.15.

architects in action, thinking whilst doing, hence for them, thinking and building always went hand in hand. From their earliest writings, published mostly in the journal *Architectural Design*, to their last publications mainly in connection with the ILA&UD, they were 'always writing with one eye on the drawing board, never travelling with words alone, but always sensitive to the meanings which words on architecture so rarely adequately convey.'⁵⁵

Unfortunately they did not have many opportunities to build although the pauses between their built projects did give them time to think and reconsider. According to their book *Ordinariness and Light*, their first period of reflection stretched from 1954 to 1962.⁵⁶ As they explained in the preface:

The first part of this book was written in 1952-1953 at the time of the Korean War. Due to the world shortage of steel, there was a pause in general building activity. This pause seemed the right moment to try to set out as clearly as we could a basis for a new beginning.

[...]

For us personally, the pause in building lasted from 1954 to 1962.

Hunstanton was their first built work and also the reason for their flying start on the British scene, due to both the importance of the competition at that time and the subsequent impact of the finished building. Between the completion of the school and The Economist project of 1959, they did not manage to build anything significant.⁵⁷ But then, in about 1960, a period of commissions and construction activity began: Upper Lawn Pavilion (1959-1962), the Iraqi House (1960-1961), the Wayland Young Pavilion (1960), the Occupational Health Clinic (1962-1964), the start of construction on the Ansty Plum in 1962, the Robin Hood Gardens (1966-1972), and the Garden Building at St Hilda's College (1967-1970). In the time between the completion of the last two buildings and the start of the works commissioned for the University of Bath in 1978, the Smithsons were confronted with yet another extended period in which they failed to materialise any of their projects: 'confronted' because it distressed them to have projects that remained on the drawing board and were never built. In the introduction to *Ordinariness and Light* mentioned earlier, they went on to say: 'Re-reading this text now is both poignant and painful, for the sense of faith and of energy just waiting to be released can still be felt.'⁵⁸ But their frustration is expressed even more eloquently at the beginning of *The Shift*, the compilation of their thoughts, after their second lull in building in the 1970s, where they wrote: 'The architect feels as man without arms, and almost without identity, if he cannot build.'⁵⁹

55 Foreword by David Dunster in Alison Smithson and Peter Smithson, *Alison + Peter Smithson: The Shift*, ed. by David Dunster, Architectural Monographs no.7 (London: Academy Editions, 1982).

56 The full title of the books is: *Ordinariness and Light: Urban Theories 1952-1960 and Their Application in a Building Project 1963-1970*.

57 Just small projects at the Caro House and the Sugden House in Watford (1955-1956).

58 Alison Smithson and Peter Smithson, *Ordinariness and Light: Urban Theories 1952-1960 and Their Application in a Building Project 1963-1970* (London: Faber and Faber, 1970). p.9.

59 Smithson and Smithson, *Alison + Peter Smithson: The Shift*. p.9.

This devastating sentence at the beginning of that monograph, which was also the first retrospective presentation of their work, was also very revealing. Their opportunities to build in their course of their career were few and yet during these fallow periods in particular they channelled all their creative energy into things ephemeral and, to be more precise, into exhibitions, as said book clearly shows. Working on exhibitions was a chance to put their ideas into practice, a chance to test some hypotheses and research some new ones. A far more powerful way to communicate and launch ideas than their essays or books. An opportunity to construct experimental ideas using transient materials but in real space.

Their first construction doldrums and period of profound reflection coincided for example with the staging of 'Parallel of Life and Art' (1953), 'Patio & Pavilion' (1956) and 'House of the Future' (1956), and the second fallow period with 'A Line of Trees' (1975-1976), 'Twenty-Four Doors to Christmas' (1979) and 'Christmas-Hogmanay' (1980-1981). All these exhibitions were landmarks in their project track record so it is no surprise that when they reviewed their own work for the first time in *The Shift* (1982) with a view to pinpointing how and where 'the shift' in their conception of architecture had occurred, they found the visible signs of this new awareness mainly in exhibitions. Just as the Smithsons made no distinction between writing and building, they distinguished even less between architecture and exhibition, or between reality and dreams when illustrating and materialising their thoughts. As David Dunster said, regardless of the medium used, the Smithsons were always in the laboratory.

The depth of thought and invention, the clarity of the architectural ideas and the rigour and cohesiveness of the architectural propositions, remind us that the Smithsons are, as it were, in the laboratory.⁶⁰

60 David Dunster's Foreword to Smithson and Smithson, *Alison + Peter Smithson: The Shift*, p.7.

Timeline

1923		Peter Durham Smithson born, 18 September	b
1928		Alison Margaret Gill born, 22 June	b
1949		A+PS marry and move to Soho, London Hunstanton Secondary School. 1949-1954. (First prize in competition)	b a
1950		Coventry Cathedral A+PS set up an office	p b
1951		Join Independent Group meetings at ICA. 1952-1955 CIAM VIII Hoddesdon.	b b
1952		Golden Lane Housing Jenkin's Cabinet / Jenkin's Room Soho House	p f p
1953	Parallel of Life and Art	Sheffield University A+PS move to Limerston Street, Chelsea, London The Trundling Turk CIAM IX Aix-en-Provence. Golden Lane Housing Competition	p b f b
1954		Team 10. Meetings at Doorn. 'Doorn Manifesto' Valley Section. 1954-1956 Crematorium at Kirkcaldy. AS Caro House Interventions. 1954-1991 'An Alternative to the Garden City Idea' Simon Smithson born	b p p a w b
1955	Hot Springs. AS The City by Day, The City by Night	PS starts teaching at Architectural Association. 1955-1960 Sugden House, Watford. 1955-1956 'The Built World: Urban Reidentification'	e a w
1956	House of the Future Patio and Pavilion	CIAM X Dubrovnik. Valley Section Grid 'But Today We Collect Ads' Appliance Houses. AS. 1956-1958	b w p
1957		Samantha Smithson born 'Aesthetics of Change' Berlin Hauptstadt. 1957-1958 Light Stick Lamp 'Cluster City: A New Shape for the Community'	b w p f w
1958	Drawings by Peter Smithson. PS	'The Future of Furniture'. AS 'The Appliance House' 'Mobility: Road Systems' Wokingham County Infants School. AS PS stays at Eameses' place. Start of friendship	w w w p b
1959		'Caravan-Embryo Appliance House' CIAM 59 Otterloo. Hauptstadt Berlin The Economist Building, London. 1959-1964 Upper Lawn Pavilion, Fonthill. 1959-1982 Churchill College, Cambridge. 1959-1982	w b a a p
1960		UPPERCASE n°3. Edited by Theo Crosby Team 10 Meeting Bagnols-sur-Cèze. Churchill College Competition	w b

a	Iraqi House, Picadilly London. 1960-1961	1960
a	Wayland Young Pavilion, Bayswater, London	
b	A+PS move to Priory Walk, South Kensington, London	1961
b	Team 10 Meeting Paris.	
b	Team 10 Meeting London. Steilshoop Competition	
b	Team 10 Meeting Drottningholm.	Extensions of Man 1962
b	'Team 10 Primer. 1953-1962'. <i>Architectural Design</i>	
b	Team 10 Meeting Royaumont. London Roads Studies, Citizens'	
p	Citizens' Cambridge Planning Study	
a	Ansty Plum, Wiltshire. PS. 1962-1992	
a	Occupational Health Clinic, Royal Park, London. 1962-1964	
b	Team 10 Meeting Paris.	1963
b	Soraya Smithson born	Painting and Sculpture of a Decade. AS 1964
b	Modern British Architects Exhibition	
p	British Embassy, Brasilia. 1964-1968	
b	Team 10 Meeting Berlin. The Economist Building, Street Project	1965
w	'The Pavilion and the Route'	
w	'The Heroic Period of Modern Architecture'	
w	'Concealment and Display: Meditations on Braun'	1966
w	<i>Portrait of the Female Mind as a Young Girl</i> . AS	
w	'Eames Celebration. A Special Number in the Work of Charles and Ray Eames': 'Just a Few Chairs and a House: An Essay on the Eames-Aesthetic'; 'And Now Dhamas Are Dying Out in Japan' 1916 a.s.o. AS	
w	A Smithson File - ARENA. Edited by Jeremy Baker	
b	Team 10 Meeting Urbino (A+PS did not attend)	
a	The Robin Hood Gardens, London. 1966-1972	
w	'Beatrix Potter's Places'. AS	1967
w	<i>Urban Structuring: Studies of Alison & Peter Smithson</i>	
a	St Hilda's College, Oxford. 1967-1970	
w	'Density, Interval and Measure'	
w	Team 10 Primer. MIT Press. AS	Wedding in the City. AS 1968
w	<i>The Euston Arch and the Growth of the London Midland and Scottish Railway</i> . AS	
w	<i>Ordinariness and Light: Urban Theories 1952-1960 and Their Application in a Building Project 1963-1970</i>	1970
p	Kuwait Mat-Building. 1970-72	
b	A+PS move to Cato Lodge, South Kensington, London	1971
w	<i>Bath Walks Within the Walls</i> . PS	
w	'Simple Thoughts on Repetition'. PS	
b	Team 10 Meeting Toulouse-Le Mirail. Robin Hood Gardens	
e	PS Teaches at Cornell. (Team 10 at Cornell University)	
w	'Signs of Occupancy'	1972
w	'Collective Design' Essays (AD 1972-75)	
f	Interdesign 2000 Furniture Competition. Family of Furniture	
p	Lucas Headquarters, Shirley. 1973-1974	1973
b	Team 10 meeting Berlin. Kuwait City Demonstration Building	
w	<i>Without Rhetoric - An Architectural Aesthetic</i> . 1955-1972	
w	'Initiators and Successors', Collective Design Essays. PS	
b	Team 10 meeting Rotterdam. Lucas Headquarters Competition	1974
e	PS joins the annual ILA&UD Workshop organized by Giancarlo De Carlo. 1974-2002	
w	'The Space Between'	
w	'How to Read and Recognise Mat-Building'. AS	
p	Magdalen College, Oxford	

1974		'Lightness of Touch'. PS 'The Violent Consumer, or Waiting for the Goodies'. AS 'Collective Quality', Collective Design Essays. AS	w w w
1975		'The Good-tempered Gas Man', Collective Design Essays. AS 'Making the Connection'. PS	w w
1976	A Line of Trees... A Steel Structure The Tram Rats Sticks and Stones. AS The Entrance Made Festive. AS	PS visiting professor at Barlett. Banister Fletcher Professorship The Yellow House at an Intersection. PS Team 10 Meeting Spoleto San Diego Chair Competition	e p b f
1977	Art into Landscape	Team 10 Meeting Bonnieux. Landwehrkanal Competition House with Two Gantries. PS Cookies' Nook. AS Verbindungskanal (Leafy Arbours). PS Pahlavi National Library, Teheran 'Risking More to the Future; Some Further Thoughts on Connection; Concerning Narrative and Change of Organisational Base'. PS	b p p p p w
1978		PS teaches in Bath. 1978-1990 Amenity Staff Building, Bath University. PS. 1978-1985 'La Qualità dell'ambiente'. AS	e a w
1979	Twenty Four Doors to Christmas. AS	'Signs of Occupancy' Lecture Everyday Architecture by 62 Practices 'In Praise of Cupboard Doors'. PS 'Connection Between New Colleges and Old City'. PS Bath University, Second Arts Building. PS. 1979-1981 'Some Further Layers: Work and Insights'. PS	b b w w a w
1980	Christmas & Hogmanay. AS	Preparation of Team 10 Exhibition in Siena. (Not held) 'Three Generations'. PS	b w
1981	Der Berlinerbaum. AS Come Deck the Hall. AS	A + PS are introduced to Axel Bruchhäuser of TECTA <i>The Heroic Period of Modern Architecture</i> 'Strati e Stratificazioni. Layers and Layering'. AS Bath University, Arts Barn. AS. 1981-1990 A+PS abandon Upper Lawn Pavilion 'The Masque and the Exhibition: Stages Toward the Real'. PS	b w w a b w
1982		A+PS visiting professors at Delft University of Technology 1982- 1983 'Parallel Inventions'. PS <i>The Emergence of Team 10 out of CIAM</i> . AS <i>Alison + Peter Smithson. The Shift</i> 'Sulla Trama del Movimento Moderno'. AS National Gallery Competition, London Bath University, School of Architecture and Building Engineering. PS 1982-1988	e w w w w p a
1983		<i>AS in DS: An Eye on the Road</i> , Delft University of Technology. AS The Economist Building, New Porch, London. PS Collectors Table. AS. 1983-1986 'To Work at the Gates'. PS	w a f w
1984	Concentricity Update. AS Cologne International Furniture Fair	A+PS visiting professors at Technical University of Munich 1984- 1985 Yellow Lookout, TECTA Factory. AS 1984-1991 'On the Edge'. PS Shinkenchiku Design Competition. A Style of the Year 2001 Thirty Years of Thoughts on the House and Housing Letter 'Top Secret. Karlchen to Snuff', TECTA Hexenhaus 1984-2001 Axel's Porch, Hexenhaus. AS. 1984-1986	e a w p w b a a
1985	10 Years Stefan Wewerka in TECTA	A+PS visiting professors at ETSAB Barcelona 1985-1986 <i>The 1930's</i> His & Her Box	e w f

w	'To Establish a Territory'. PS		1985
w	'Conglomerate Ordering'. PS	The Future of Furniture - Furniture of the 4th Generation. AS	1986
w	'New Portal: Santa Maria della Scala, Siena'. PS		
w	<i>Upper Lawn. Folly Solar Pavilion</i> , Barcelona School of Architecture		
a	TECTA Factory, Interventions and Additions. 1986-2001		
a	Toilet Tree, TECTA Factory. AS. 1986-1990		
f	Waterlily and Fish Desk. AS		
f	Struwwelpeter's Wall Cabinet. AS		
f	Plant Frames: Chinese Mountain Plant Brace, Chinese Rock Plant Training Frame, Plant Mast, Lozenge Plant Trainer, Ping-pong Plant Trainer, Frond Plant Mast, Mogul Disc Plant Trainers, Plan Guards	Triangle Artists' Workshop	1987
w	'Janus-Thoughts for Siena'. PS		
f	Cornell Boxes. AS		1988
f	Jewel Box. AS		
w	'Think of It as a Farm'. PS		
w	'San Miniato Tower'. PS		
p	Bibliotheca Alexandrina. 1989-1991		1989
a	Riverbank Window. AS		
w	'Into the Air'. AS		
f	Housegarden. 1989-1993		
w	'Shifting the Track'. PS		
w	'San Miniato Park'. PS		
b	This is Tomorrow Exhibition Reconstructed, ICA, London		1990
p	Beverungen Roof. AS		
e	A+PS Lecturing in the University of Witwatersrand. 1990-1991		
w	'The "As Found" and the "Found"'		
w	<i>Hieronymus / Saint Jerome. The Desert - The Study</i> . AS		
w	'My Kind of Town'. AS		
p	Acropolis Museum. 1990-1992		
a	Weaving Room, Sitting-out Area, TECTA Factory. AS		
a	Canteen Porch, Path to Pavilion, Threshold, TECTA Factory. AS		
a	Hexenhaus Holes. AS		
a	Alterations Brodia Road, Stoke Newington. 1990-1995		
w	'The Recovery of Parts of the Gothic Mind'. PS		
w	'A Notation of Trees'. PS		
a	Factory Corridor, Picture Layout, TECTA Factory. AS	Saint Jerome: The Desert – The Study. AS	1991
w	<i>Team 10 Meetings 1953-1984</i> . AS	Speaking to the Sky	
a	Hexenbesenraum, Hexenhaus. AS. 1991-1996		
f	Silk Lantern. AS		
f	Tischleindeckdich. 1991-1993		
w	'The Nature of Retreat'. AS		
b	<i>A + P Smithson: Pensieri, Progetti e Frammenti fino al 1990</i>		
w	'Functional to Passage'. PS		
a	Sewing Room Porch, TECTA Factory. PS. 1992-1996	Modern Architecture Has Been with Us for Four Generations. AS	1992
a	Yard Gates, TECTA Factory. AS		
w	'Markers on the Land'. PS		
w	<i>Italian Thoughts</i>	TischleinDeckDich. AS	1993
_	Momentos of Karlchen, Hexenhaus. AS		
b	AS dies, 16 August		
w	'Particularity: More Praise of Cupboard Doors'. PS		
w	<i>Imprint of India</i> AS		
b	Climate Register Exhibition. L. Wong and P. Salter		1994
w	<i>Changing the Art of Inhabitation</i>		
w	'Sky'. PS		
b	A+PS A Celebratory Exhibition. M. Vidotto and A. Mazzini	Cologne International Furniture Fair. PS	1995
b	Book Work by Alison Smithson. AS		
a	Sauna, Hexenhaus. PS. 1995-1998		
w	'Re-Staging the Possible'. PS		
a	Stainless Steel Fascia, TECTA Factory. PS		
a	Axel's Room Porch, TECTA Factory. PS		

1996		Bathroom, Hexenhaus. PS. 1996-1997	a
		Weaving Room Porch, TECTA Factory. PS. 1996-1997	a
		Office Corridor Doors, TECTA Factory. PS. 1996-1997	a
		Pier and Bridge, Hexenhaus. PS	a
		Axel's Bedroom, Hexenhaus. PS	a
		'Empooling'. PS	w
1997		Panorama Porch, TECTA Factory. PS. 1997-1998	a
		Tea-house, Hexenhaus. PS	a
		Window to Weser, Hexenhaus. PS	a
		Living Room Bay, Hexenhaus. PS	a
		Bridge to Upper Walkway, Hexenhaus. PS	a
		Exhibition A&PS Durham School of Architecture	b
		<i>Modernism Without Rhetoric: Essays on the Work of Alison and Peter Smithson.</i> Helena Webster	b
		Lattice Chair. PS	f
		Lattice Paravents. PS	f
		'Being at Home'. PS	w
1998	On the Floor Off the Floor. PS Toy Town Exhibition. PS	Lattice Furniture: Sofa, Table, Cupboard. PS	f
		Popova's lattice chair. PS. 1998-1999	f
		Metal Workshop Porch, TECTA Factory. PS. 1998-2000	a
		Entrance Hall - Factory Corridor, TECTA Factory. PS. 1998-1999	a
		Entrance Hall - Screen to Garden, TECTA Factory. PS. 1998-1999	a
		Benches in Living Room, Hexenhaus. PS	a
		Front Door Porch, Hexenhaus. PS	a
		'Lattice Screens and Paravents', TECTA. PS	w
		'Fortifications'. PS	w
1999	Lattice Furniture Stand. PS	Houses on Childrens Books. AS and Alan Powers	w
		<i>Rearrangements: A Smithsons' Celebration.</i> OASE	b
		<i>Flying Furniture: Unsere Architektur Rollt, Schwimmt, Fliegt = Our Architecture Rolls, Swims, Flies.</i> PS	w
		'The Lattice Idea'. PS	w
		Put-Away House. PS. 1999-2007	a
		Karlchen's Flag Tower, Hexenhaus. PS	a
		Kitchen Window and Garden Store Door, Hexenhaus. PS	a
		Kitchen, Hexenhaus. PS	a
		Father's Room, TECTA Factory. PS	a
2000	Popova's Chair Exhibition. PS Flying Furniture. PS	'Arquitecturas Silenciosas' Exhibition	b
		Lantern Pavilion, Hexenhaus. 2000-2001	a
		Bridge From Pier to Upper Walkway, Hexenhaus. PS	a
		Hole, Kitchen to Second Bunk, Hexenhaus PS	a
		Axel's Porch Extension, Hexenhaus. PS	a
		'Inside Outside: Outside Inside'. PS	w
2001		<i>The Charged Void I: Architecture</i>	w
		'From Above and to Above'. PS	w
2002		Hadspen Obelisk	a
		'Sideways - Skyways'. PS	w
2003		TECTA Chair Museum. 2003-2007	a
		'From the House of the Future to the House of Today' Exhibition	b
		<i>The Charged Void II: Urbanism</i>	w
		PS dies, 3 March	b

a: Built architecture, b: Biography, e: Education, f: Furniture, p: Projects and Competitions, w: Writings.

Alison and Peter Smithson through their exhibitions

Since our opportunities to build come so rarely, we always seize exhibition opportunities to project our ideas beyond our aesthetic – as if our ideas had already leavened the situation – and making correspondingly advanced assumptions for every field of endeavour likely to affect the house – we step into the Future.⁶¹

Alison and Peter Smithson are outstanding figures in the history of twentieth century architecture. Exhibitions, in the sense of built thoughts, were showcases for ideas that illustrated and sometimes anticipated their words, and may, therefore, be regarded as landmarks amongst their own works in which they also offered some of their most intense moments.

The Smithsons were aware of the potential of exhibitions and said so clearly in ‘The Masque and the Exhibition: Stages Towards the Real’, a lecture that was subsequently published as an article in the *ILA&UD* yearbook of 1981. The lecture revealed, by means of parallels between the three generations of the Renaissance and modernity (the subject of the ‘Three Generations’ conference given the previous year), how exhibitions (the Renaissance ‘masque’) were used as a space for experimenting with emergent ideas in both modernity and the Renaissance.

In the Renaissance, between the idea sketchily stated and the commission for the permanent real place came the stage-architecture for the Court Masque, the architectural settings and decorations for the birthday of a favourite prince or the wedding of a ducal daughter; these events were used by the architects of the Renaissance as opportunities for the realization of the new style: the new sort of space and the new forms of decoration made real for one day only perhaps, but still real. The real before the real.⁶²

According to the Smithsons, modern architecture follows this old tradition. In the first generation: Le Corbusier and Pierre’s Jeanneret’s *Pavilion de l’Esprit Nouveau* (1925), Mies van der Rohe and Lily Reich’s ‘Mirrorglass Exhibition’ and ‘Silk Exhibition’ (1927), Gropius’s ‘Werkbund Exhibition’ (1930), etc. In the second generation, it was mainly the Eameses, who also, again according to the Smithsons, pursued the inherited language of modern architecture through exhibitions. Finally, the article adds the Smithsons’ own exhibitions to the family tree of modern architecture: ‘We in the Third Generation of the *Three Generations*, found in the ‘fifties that we could realize ideas only as allegory; that is obliquely, yet in real space, in exhibitions...’ and refers to some of their best-known exhibition architectures: ‘Parallel of Life and Art’ (1953), ‘Patio & Pavilion’ (1956), ‘House of the Future’ (1956), ‘Painting and Sculpture of a Decade’ (1964), ‘Wedding in the City’ (1968), ‘The Entrance Made Festive’ (1976), ‘Twenty-Four Doors to Christmas’ (1979), ‘Christmas-Hogmanay’ (1980), plus the ‘Come Deck the Hall’ exhibition that they planned to hold the following year.

Ten years later a revised version of that article was published in the compilation

61 Alison Smithson and Peter Smithson, ‘Thirty Years of Thoughts on the House and Housing’, in *Architecture in an Age of Scepticism*, ed. by Denys Lasdun (New York: Oxford University Press, 1984), pp. 172–91.

62 Peter Smithson, ‘The Masque and the Exhibition: Stages Towards the Real’, *ILA&UD Yearbook 1981*, 62–67.

Italian Thoughts under the title, 'Staging the Possible', which added new layers of thought to those set forward originally. The counterpoint of 'the permanent' or 'real life' was now incorporated into the exhibitions of the three generations presented in the article of 1981 in order to make the connection between transient stage-architecture and permanent, real-life architecture even more obvious, such as, for example, between the Pavilion de l'Esprit Nouveau and the version built in Le Corbusier's studio on rue Nungesser et Coli; the 'Silk Exhibition' and the Tugendhat; the 'Werkbund Exhibition' and the electricity showroom on Regent Street, the Eameses' Herman Miller showrooms and their own house in Santa Monica, etc. The Smithsons also considered, of course, the same connections in their own work, for example, between 'Parallel of Life and Art' and Axel's Porch at the Hexenhaus; between 'Patio & Pavilion' and Upper Lawn; between 'House of the Future' and the Iraqi House; and between 'Painting and Sculpture' and Building 6 East at the University of Bath. The revised article ends by emphasising the idea that exhibitions are part of an intellectual process that enables thought processes to be put into practice: first they are staged, then built. In this process, as Enric Miralles pointed out in the quotation at the beginning of this chapter, the conclusions are temporary.

All our exhibitions with the intention of pleasing and intriguing their makers and participants, have allowed us the insights that come with the realization of an architectural idea, in real materials and in real space, in advance of more permanent – and therefore functionally-difficult and weather-serious construction...⁶³

In 1995 in 'Restaging the Possible', the third and last article in this series, Peter Smithson emphasizes the same idea but now distinguishes between two types of exhibition: exhibitions of emergence, 'from the time when ideas are emergent', and exhibitions of reflection, 'conscious acts of interpretation by others'.

In the 1990s a new period began in which the Smithsons were linked for the first time to the staging of their own work: Augusto Mazzini and Marco Vidotto's 'Alison + Peter Smithson' inaugurated in Rome in 1991, and 'Climate Register' at the Architectural Association in 1994 by Lorenzo Wong and Peter Salter. When the Smithsons saw the material on show in Rome (the first retrospective exhibition of their work), a recurrent underthought in their 'set of mind' as they called it suddenly became obvious: the interaction between the ephemeral and the permanent.

In our work the ephemeral and the permanent intertwine. The ephemeral being works on paper... Christmas cards in miniature space, invitation cards, posters, photographs, books in which ideas are tried out; performing the same role in the small as exhibitions at real scale... in transient material in advance of permanent construction.⁶⁴

Aware of the many possibilities of exhibitions as a powerful tool for architecture, Alison and Peter Smithson used them to put their ideas into practice throughout

63 'Staging the Possible' Smithson and Smithson, *Italian Thoughts*. p.22.

64 Peter Smithson, 'Restaging the Possible', *ILAC&UD Yearbook 1995*, 42–49.

their career from 'Parallel of Life and Art' in 1953 to 'Flying Furniture' in 2000. A closer look at the timeline reveals that the Smithsons' periods of reflection and lulls in their building activity coincide with the times when they were busiest with exhibitions – an indication of how important these opportunities to stage their ideas were in those periods. However, even in their busiest construction periods they continued to experiment in parallel with the ephemeral. This is why their exhibitions constitute a coherent group of projects, a corpus of work making it possible to track the purest essence of their architectural thinking.

In the 1950s, the Smithsons began working on exhibitions linked to the London scene (particularly to the British discussion forums they had just joined):

'Parallel of Life and Art' (1953) with Nigel Henderson, Eduardo Paolozzi and Ronald Jenkins which re-structured the space inside the Institute of Contemporary Arts by means of an envelope of images that seemed to float in mid-air, the intention being to give some evidence of a new attitude.

'The City by Day, the City by Night' (1955) in conjunction with the MARS group in the 'Turn Again Exhibition'. A joint protest against the decline in architectural standards in the City of London which also provided some hopeful possibilities for the future.

'House of the Future' (1956) at the 'Ideal Homes Exhibition' was presented as the house twenty-five years hence and enabled them to reflect upon suburban housing in an incipient consumer culture and the inherent qualities of new materials.

'Patio & Pavilion' (1956) with Nigel Henderson and Eduardo Paolozzi in the 'This is Tomorrow' group exhibition. Here the Smithsons presented a reflection on territory and occupancy in a kind of symbolic habitat. An intellectual allegory about what they regarded as basic human needs, in which architects provided a framework inhabited by artists.

'Extensions of Man' (1962) was designed by Reyner Banham with a view to removing the poor impression that the Festival of Britain had left in his intellectual circle. The Smithsons' proposal was to exhibit an open aesthetic based on a network of human relations. In the end this exhibition was not held.

'Painting and Sculpture of a Decade 1954-64' (1964) transformed the halls of the Tate Gallery into a single, seamless space made to suit the circulation routes and links established between the works of art on show.

In the late 1960s and the 1970s, together with other colleagues from the inner circle of Team 10, the Smithsons designed their first exhibitions outside the British scene and took part in two major international exhibitions: the Triennial of Milan and the Biennial of Venice.

'Wedding in the City' (1968), in the '*Il Grande Numero*' ('The Great Number') section of the XIV Triennial of Milan, explored the theme of the city as a built fabric and how it interacts with the changes caused to the city by events or invisible decorations.

'Sticks and Stones' (1976) was presented at the 'Europa-America. Architettura Urbana/Alternative Suburbana' exhibition as a proposal prompting people to think

about the physical quality of architecture in all stages, ranging from buildings under construction to even the quality of place of a ruin.

In the mid-1970s at the Art Net gallery run by Peter Cook – a gallery which, despite only being open to the public for five years, had a considerable impact on London's architectural community – the Smithsons staged their last two presentations before quitting the London scene:

'A Line of Trees... A Steel Structure' (1975) which used a series of overlapping, transparent panels with coloured latticed images to convey what it would have felt like to inhabit the Lucas Headquarters project, and

'The Tram Rats' (1976) which was part of 'The Rally: Forty London Architects', a group exhibition in which they presented a story for adults and children about trams to make people think about industrialised society. This exhibition marked the end of a line of research inherited from the first period of modernism.

At the end of the 1970s, in just five years from 1976 to 1981, they worked on four exhibitions related to Christmas and, in particular, the popular celebrations traditionally associated with it.

'The Entrance Made Festive' (1976-1977) was part of the seminar Signs of Occupancy taught at Bartlett School, in which the students decorated the school entrance in the run up to Christmas.

'Twenty-Four Doors to Christmas' (1979) transformed the Kettle's Yard gallery in Cambridge by building a metaphorical, three-dimensional advent calendar showing different aspects of English Christmas traditions with a view to making the visitors aware of their collective and shared responsibility for the use and appearance of places.

'Christmas & Hogmanay' (1980-1981) immersed visitors in a Scottish Christmas atmosphere created by latticed cages and the associated exhibits, and made visitors undeniably the main actor in the exhibition.

'Come Deck the Hall' (1981) was never actually held but took this concept one step further by suggesting an event that the public would actively participate in by adding their own ephemeras to the exhibition.

As a result of their unfailing commitment, and in order to share their opinions and thereby encourage reflection and discussion, the Smithsons did not hesitate to take part in competitions and exhibitions intended to offer different points of view on paper: just architectures on paper to be exhibited.

'Art into Landscape' (1977) was a series of projects for the transformation of former industrial sites into 'places to go to' able to sustain a continuing yet fresh life. Such projects included Tees Pudding, Swinging Elland, and the Kingsbury Lookouts.

'Der Berlinerbaum' (In memoriam Kongreßhalle Berlin) (1981) proposed a 'built' tree for the bear that symbolises Berlin and, alongside the tree, an unassuming ruin in response to the self-destruction of the Kongress Halle, the ruin of their earlier competition project for the unrealised Coventry Cathedral (1951).

'Concentricity Update' (1984) was a project to refurbish several gas holders as

housing, and enable them to act as a connective framework that celebrated their uniqueness whilst earmarking the land and highlighting the concentricity of the original garden. This was the Smithsons' personal solution for the new public housing which New York City intended to build next to Adam Purple's Garden of Eden following the competition held by the Storefront for Art and Architecture Gallery.

Concentricity Update was the Smithsons' first exhibition outside Europe but not the only one in which their ideas transcended that context.

'Triangle Artists' Workshop' (1987) was where the Smithsons decided to address the sky together with their work team of artists, focussing their efforts on the roof of an abandoned dairy in Pine Plains. Another two 'devices' (a plywood screen and a steel mast) were built to extend the project building up into the air and the landscape.

'La Ville en Jeux / Toy Town' (1998) was an exhibition in which the exhibits were chosen by a curator and the Smithsons were only responsible for the exhibition design based on 45° angles and a frame made of 'as found' steel triangles. Surprisingly, Peter Smithson described this exhibition structure as the 'simplest statement of the nature of Brutalism'.

The Smithsons' largest group of exhibitions consisted of those developed whilst working with Axel Bruchhäuser, the proprietor of the ТЕСТА furniture factory. For almost twenty years, they not only developed furniture prototypes and carried out many projects at both Bruchhäuser's home and his factory, but also joined forces with him to stage their ideas in eleven exhibitions including particularly:

'Saint Jerome: The Desert – The Study' (1991) which was the physical construction of a reinterpretation of the study depicted in Antonello da Messina's famous painting plus a short but very profound essay by Alison. These thought-provoking items aimed to add an element of criticism and discussion to the Milan furniture fair and make people think about the most human side of inhabitation.

'Tischleindeckdich a.s.o.' (1993) was named after its focal point, a table designed by the Smithsons. The table was surrounded by a 'fairy' atmosphere created by theatrical lighting and colour which transformed the individual pieces of furniture and made them merge together into an 'ensemble'.

'On the Floor Off the Floor' (1998) presented furniture as a vehicle for different lifestyles by toying with the influence of old and young age on contemporary seating solutions. The two proposals were divided by a folding screen that pursued and developed the lattice concept begun three decades earlier, and played an equally important but discreet role in the underlying concept of this exhibition.

These are just some of the most important exhibitions staged by Alison and Peter Smithson over a period of five decades. The quantity and quality of the ideas they put forward leave no doubt about the importance of exhibitions in the development and dissemination of their architectural thinking.⁶⁵

65 The complete list of exhibitions in which Alison and Peter Smithson took part, according to the research conducted by the author of this thesis, appears at the end of the introduction.

As a result, many of the exhibitions in the first period, particularly those staged in the 1950s have been studied and referred to by critics a great deal, and have even become better known and had more media impact than their built work. The exhibitions ‘Parallel of Life and Art’, ‘Patio & Pavilion’, ‘House of the Future’, ‘Painting and Sculpture’, and ‘Wedding in the City’, all from the first period, have entered the general iconography of modern architecture – paradoxically on account of their ephemeral nature. However, from the 1970s onwards, particularly after the Smithsons disappeared from the London scene, little is known about their prolific exhibition work.

The fact that exhibitions were always a powerful tool for materialising and transmitting the Smithsons’ ideas – and much more obviously, furthermore, after Peter Smithson mentioned in his ‘The Masque and the Exhibition’ conference at the ILA&UD in 1980 how important exhibitions were to their architecture – made the author of this thesis think that the exhibitions staged after that period, despite not being widely known, must have been of an intensity similar to those highlighted up until then in the media. This fact, together with the expectations raised by the ‘Christmas-Hogmanay’ exhibition after analysing the collage mentioned at the beginning of this PhD thesis, caused the research presented herein to be channelled towards this final period of the Smithsons’ exhibition architecture. The research focuses specifically on two groups that stand out from the range of documented exhibitions on account of their intellectual cohesion: the Christmas-themed exhibitions including the enigmatic Christmas-Hogmanay, and those produced subsequently in conjunction with Axel Bruchhäuser of ТЕСТА.

1981: Time for reflection

Every now and then it seems possible to decipher a new pattern in work already accomplished: A pattern thrown into relief by present concerns. These fresh insights lance through the body of work, showing as it were, another grain; enabling us not only take fresh pleasure in what we have done – but more importantly – to draw the necessary from our corpus of work in order to proceed. This reconsidering of a body of work is not unlike a prism, this way and that, so that catching the light differently, we see fresh colours.⁶⁶

According to Max Risselada, this text written by Alison Smithson probably referred to the ‘Christmas-Hogmanay’ exhibition which she curated and staged at the Fruitmarket Gallery in 1980. However, after analysing the collage found, as mentioned earlier in the prelude to this dissertation, amongst the documentation of said exhibition, her words might also be said to refer to said collage. In the collage, Alison identifies three underlying layers in her work: history, lattice and space (‘a pattern thrown into relief by present concerns’) which are interwoven and seem to merge together to create new tools (‘fresh colours’) with which to pursue their commitment to architecture.

In any case the start of the 1980s coincided with a time in Alison and Peter Smithson’s career when, for several reasons, they were looking back hard and thoughtfully at the past. They had come of age as professionals, it was thirty years since they won the Hunstanton competition, and once again, as in the late 1950s, it was several years since they last built anything. A professional doldrums which, once again, they filled with ephemerals and writing.

From the mid-seventies, they worked on presenting their work in *The Shift* (a ‘treatise’ in their own words⁶⁷) which was finally published in 1982. The editor, David Dunster, explained in the foreword: ‘One half of this issue contains an essay by the Smithsons documenting what they term “The Shift”. [...] The second half illustrates buildings and projects which are crucial to this change. [...] This unusual format has been worked out with the architects, and arises from the desire to show the relationship between thought and action which has characterized their work.’⁶⁸ This publication not only compiled their work from Hunstanton up to the time of publication but also reviewed and reinterpreted it from a new angle that provided new insights that would enable them to move forward into the future.⁶⁹ A reinterpretation ‘that also left scope for readers/spectators to appropriate the work in order to propagate it via their own interpretation’.⁷⁰

It was also in the mid-1970s that Alison Smithson began to gather and prepare

66 Alison Smithson ‘A History of Three Natures of Layering Becomes a History of the Architecture of Our Exhibitions’. Unpublished manuscript reproduced in Risselada. p.19.

67 Peter Smithson, ‘The Masque and the Exhibition: Stages Towards the Real.’

68 Smithson and Smithson, *Alison + Peter Smithson: The Shift*. p.6.

69 In addition, upon examining their own work retrospectively, they saw that ‘the preparation for this shift and the first evidence of it happening can be found in the ephemera of our [their] work’. (Ibid. p.9)

70 Risselada. p.29.

information for the manuscript that was finally published in 2003 as *The Charged Void*. She worked on it untiringly until her death in 1993, when Peter resumed and put the finishing touches to the manuscript. An indication of the enormous, on-going task of revision, re-drafting and reinterpreting their own work which coincided with their second period of reflexion around 1980.⁷¹

This moment of reflection and lucid revision also gave rise to some of the Smithsons' most notable writings including 'Some Further Layers' (1978), 'Three Generations' (1980), 'Layers and Layering' (1981), and 'The Masque and the Exhibition' (1981), all of which were published in the journal *Spazio e Società* and the ILA&UD yearbook, both directed by their Team 10 colleague, Giancarlo De Carlo.

The end of the Team 10 meetings

The death of Jaap Bakema in February 1981 also brought the Team 10 meetings to an end, although some of its members continued to get together informally to exchange ideas. Consequently the Team 10 meeting scheduled for the autumn of 1981 in Lisbon never took place although the Smithsons and Guillermo Jullian de la Fuente did go ahead and visit Amancio Guedes there.

The last time the inner circle met was in Bonnieux in 1977, where several collaboration ideas for Team 10 arose which would enable them to appear in the media as a group taking a stance against the upsurge in postmodernism, i.e. by participating in the Venice Biennial, making a live Team 10 show, joining the second International Building Exhibition (IBA) planned for 1984 in Berlin, etc. But for different reasons, none were actually implemented except the publication of a special Team 10 issue of *Deutsche Bauzeitung*.⁷²

From this time onwards, Alison and Peter Smithson and the other members of Team 10 would use mainly teaching and journals to disseminate their ideas. Giancarlo De Carlo, in fact, regarded the ILA&UD, an international workshop formed by a group of European and American universities, as 'De Carlo's version of Team 10, enlarged to include new voices, open to universities and students, combining the moral legacy of CIAM and the energies of Team 10',⁷³ and every summer after its creation, Peter Smithson attended this event and contributed new concepts to the general discussion by giving lectures which were subsequently published in the respective yearbook.

Hence Peter Smithson was involved in teaching at ILA&UD from 1976 onwards but also to a great extent at the University of Bath where he was a visiting professor

71 It must also be remembered that, as Dirk van den Heuvel pointed out, this revision was also prompted when they moved house to Cato Lodge in 1972. The new house gave Alison the opportunity to have a little cabinet room as a space of her own that was also the 'Archive'. A place for writing and reflection. Dirk van den Heuvel, 'Alison and Peter Smithson: A Brutalist Story, Involving the House, the City and the Everyday (plus a Couple of Other Things)', 2013. p.316.

72 For more information about the details of this meeting, see Max Risselada 'Making Plans for the Future' Max Risselada and Dirk van den Heuvel, eds., *Team 10. In Search of a Utopia of the Present 1953-81* (Rotterdam: NAI Publishers, 2005).

73 Mirko Zardini 'ILA&UD 1974-2004. Giancarlo De Carlo and the International Laboratory of Architecture and Urban Design' in Risselada and van den Heuvel. p.216.

from 1978 to 1990. At Bath, in addition to teaching, the Smithsons also began to receive commissions: a masterplan and a series of buildings on the University of Bath campus. This project gave the Smithsons the opportunity to build again after a lull of more than ten years (their previous commission had been the Garden Building in Oxford in 1967) and to start putting into practice all the concepts they had accumulated and presented in writings and exhibitions until that time. It was mainly Peter, because of his proximity to the project due to teaching there at the same time, who was more involved in the process, a combination of theory and practice, teaching and building, reflection and construction spanning more than ten years.

Alison meanwhile also taught occasionally at the Architectural Association and began to teach abroad. In 1982, she and Peter held the chair created after the death of their colleague Jaap Bakema at the Faculty of Architecture in Delft for one year. She was subsequently a visiting professor in Munich (1984-1985), Barcelona (1985-1986) and Johannesburg (1991). Meanwhile, she continued the task of compiling and reviewing their work, she worked on the occasional project or competition and, above all, she began the close-knit connection and collaboration in all respects with the furniture manufacturer Axel Bruchhäuser and ТЕСТА in Germany.

Peter Smithson in Bath and in Urbino for the ILA&UD summer workshops. Alison Smithson in her little 'cabinet room' at Cato Lodge, with the occasional trip abroad to teach and exchange ideas with Axel Bruchhäuser in Lower Saxony. The Smithsons had disappeared from the London scene and their voice was no longer heard in international groups. As Peter Smithson said to Marco Vidotto with ironic and detached realism on 20 November 1981, 'Our influence on contemporary architecture vanished with an aspirin.'⁷⁴

Out of the London scene

The 1970s were a time of crisis – not only for the Smithsons but in all spheres. The oil crisis, first in 1973 and then in 1979, entailed an economic crisis that even caused a shift in the economy from the welfare state to the advent of neoliberalism and market economy.

Great Britain played a fundamental part in creating the architectonic culture of the post-war period because, together with the upsurge in modernity, 'the direct involvement of the state in post-war reconstruction and new housing combined to give architects unprecedented responsibility and status'.⁷⁵ From the late 1950s to the 70s, however, a brain drain of British intellectuals who internationalised American academia occurred, lured to the United States 'by the exotic culture of consumption and the prospect of more glamorous and better-paid work'.⁷⁶ This was the case of Colin Rowe, Kenneth Frampton, Alan Colquhoun, Robert Maxwell and Reyner Banham, amongst others, and more sporadically, others holding visiting positions,

74 Vidotto, *Alison + Peter Smithson. Obras y Proyectos*, p.19.

75 Mark Crinson and Claire Zimmerman, eds., *Neo-Avant-Garde and Postmodern: Postwar Architecture in Britain and Beyond* (New Haven & London: The Yale Center for British Art and The Paul Mellon Centre for Studies in British Art, 2010). p.12.

76 Ibid. p.14. The introduction of this publication examines in depth the contextualisation of this period.

such as James Stirling and Colin St. John Wilson. Alison and Peter Smithson, however, despite the crisis, the lack of commissions and their disappearance from the British scene, never abandoned England. Alison Smithson, in an article published in *The Sunday Times Magazine*, acknowledged the reasons and consequences of this decision: 'We have taken some quite rigid ethical positions, for example with regard to state schooling, because my husband was against any expense that would have obliged us to take on projects we did not really want...'⁷⁷

Following their meteoric rise in the 1950s and early 60s as the long awaited prophets of a new generation, by the mid-1970s they had disappeared from London and the British and international media. *Architectural Design* was the vehicle that had offered to spread their ideas amongst a wider audience thanks to the friendship and similar outlook they shared with its editors, Monica Pidgeon and Theo Crosby. As well as regularly contributing articles about their concerns at any given time, they were also guest editors of several numbers including 'Team 10 Primer' (1962), 'The Heroic Period of Modern Architecture' (1965), and 'Eames Celebration' (1966). The last series of articles that they published in the journal in the 1970s, entitled 'Collective Design', was described as 'consciously building towards group form and towards group building, making places which, of themselves indicate connection to wider collective activities',⁷⁸ and included 'Signs of Occupancy' (1972) and 'Lightness of Touch' (1974). The last article published in *Architectural Design* was 'Making the Connection' in 1975. In 1976 the journal's publisher and editorship changed, and the Smithsons' voice finally fell silent.⁷⁹

Similarly, their only appearance in exhibitions staged in London in the 1970s was due to the self-professed admiration for them by Peter Cook (co-founder of Archigram) who established and directed the Art Net gallery from 1972 to 1979. He offered them the forum for building a 'simulacrum of the effect aimed at in the real space of a built project', i.e., the Lucas Headquarters project in the exhibition 'A Line of Trees... A Steel Structure'. He gave them the opportunity to realise their architectonic concepts with transient materials but in real space.⁸⁰

Peter Cook was also responsible for selecting the forty architects to take part in 'The Rally: Forty London Architects', a 1976 exhibition which, in his own words, was inspired, twenty years on, by the influential exhibition 'This is Tomorrow' held in 1956: 'I like to think that it illustrates the overriding tolerance of the London architectural world that is (in the final analysis) a strength rather than a weakness.'⁸¹

77 *The Sunday Times Magazine*, 30 August 1987 reproduced in Vidotto, *Alison + Peter Smithson. Obras y Proyectos*. p.18.

78 Peter Smithson, 'Collective Design: Initiators and Successors', *Architectural Design*, October (1973), 621.

79 For more information, see the essay by M. Christine Boyer 'Architectural Design and the writings of Alison and Peter Smithson (1953-75)' published in Risselada and van den Heuvel. p.199.

80 In the outline of the exhibition published in the magazine *Net*, they mentioned the link between that exhibition and the ideas they published in *Architectural Design*: 'It is a worked example of the ideal of the collective design' *Net*, no.2 (London: Art Net Gallery, 1976).

81 Peter Cook, 'Introduction: Forty London Architects', *Net*, no.3 (London: Art Net Gallery 1976). Number three of the architecture and art review and a catalogue about the Rally and this exhibition.

His selection of architects was strictly personal (a mixture of fascination, tolerance, intrigue, admiration, ...) which explains why such apparently unrelated architectures went on show, and included Venturi, Hollein, Lasdun, Alsop, Grimshaw, Tschumi, Foster, Venturi, Gowan, Guedes, Herron, Koolhaas, Krier, Rogers, and also the Smithsons with their story 'The Tram Rats', even though they were no longer in fashion.

From their Italianate retreat near Fulham Road, with its eerie calm, they continue to think: without the wish to look over their shoulder. Frustrated and disappointed by the British lack of enterprise, they continue on their elitist, but totally honest and genuinely intellectual path towards Truths via Ideas, via Places and via Things. They do not care to be fashionable, but they do care to communicate: albeit through predetermined sieves of myth and language. Very English. Very Beatrix Potter.⁸²

The above quotation taken from the biographical comment published in the journal *Net* along with the review of the 'A Line of Trees... A Steel Structure' exhibition is a very eloquent description of the Smithsons' circumstances in the late 1970s. The boom in postmodernism had wiped them off the map but they did not let themselves be blown off course and always remained true to their principles, like the nonconformist and superlatively independent intellectuals they had always been.

The upsurge in postmodernism

Postmodernism arose in the USA in the 1970s. Robert Venturi and Denise Scott-Brown who championed this trend, used a sociological understanding of visual communication as the basis for drafting new guidelines for modern architecture.⁸³ Along with them, the main proponents of the debate were Robert Stern, Charles Moore, Peter Blake, Philip Johnson and Vincent Scully, all from the USA, and the British expatriate Colin Rowe. They insisted on the 'complexity of modern architecture and the need to recuperate the significant capacity reduced by the change in the avant-garde.'⁸⁴ The postmodernism seeking to communicate by a return to classical language was consolidated in the USA by the exhibition and catalogue entitled 'The Architecture of the École de Beaux-Arts' staged in 1977 at the omnipresent Museum of Modern Art of New York and curated by Arthur Drexler.

One year later, Aldo Rossi, an advocate of reviving the art of architectural composition, geometry, and memory, succeeded Vittorio Gregotti as the curator of the Venice Biennial, and his *Teatro del Mondo* in 1979 was a clear indication of the impact that postmodernism was already beginning to have on architecture in Europe. It finally asserted itself as a leading internationally known approach in 1980 with Paolo Portoghesi's 'Strada Novissima'. The staging of the twenty façades conceived of

82 Short biographical note signed by Peter Cook accompanying the outline of the exhibition 'A Line of Trees... A Steel Structure' in the journal *Net* no.2.

83 Scott-Brown learned from the Smithsons about their concern for everyday reality and its sociological implications. 'During Denise Scott-Brown's time in England, she moved in the circles of the Architectural Association and Institute of Contemporary Arts just at the moment when the avant-garde scene was most concerned with the impact of the consumer society.' Crinson and Zimmerman. p.14.

84 Pere Hereu, Josep Maria Montaner and Jordi Oliveras, eds., *Textos de Arquitectura de La Modernidad* (Madrid: Editorial Nerea, 1994). p.435. Our translation.

as theatre wings on a hypothetical postmodern 'street' at last marked the assimilation of postmodernism in Europe on a large scale, and became a symbol of the movement itself.

Rem Koolhaas took part in said exhibition but to manifest his opposition: 'The 'Strada Novissima' showed what architecture, ruled by the market economy, would imply.'⁸⁵ Moreover, as Koolhaas himself said in a recent interview with Léa-Catherine Szacka and Stefano de Martino, 'the funny thing was that Venturi, at the time ['Strada Novissima'], was very much criticized, even in America. In New York the scene was dominated by Peter Eisenman and Robert Stern, and the two of them agreed that Venturi should be 'out'.⁸⁶ Eisenman belonged to a group known as 'The New York Five' along with Michael Graves, Charles Gwathmey, John Hejduk and Richard Meier. The group was named after the 1969 exhibition of their work at the Museum of Modern Art of New York. This group was critical of realism and functionalism and determined to find a new formal abstraction to launch a new era, a non-classical age which had yet to find its bearings.

In Europe, the exhibition also prompted a critical response from a younger generation, albeit in small circles, including Marco Vidotto and Augusto Mazzini who regarded Team 10 as an alternative based on different principles in contrast with the meteoric rise of the omnipresent postmodernism. In 1981, after visiting the Venice Biennial with its paper-mâché façades, they planned to hold a Team 10 counter exhibition in Siena (the venue for the ILA&UD workshops at that time). 'The main point was not to make a retrospective or historical exhibition of Team 10 as we [they] knew well that the members would not have accepted participation in anything that was somehow historicizing Team 10, declaring them as a past story. They were however interested to see in what way young architects had received the ideas of Team 10.'⁸⁷ Indeed, as part of the exhibition and with a view to making it even more lively, the inner circle of Team 10 – José Antonio Coderch, Giancarlo De Carlo, Ralph Erskine, Alison and Peter Smithson, and Aldo van Eyck – was invited to take part with small-scale projects.

From the outset Alison and Peter Smithson were excited about the idea because they had wanted to do something as a group since the 1977 meeting in Bonnieux. The organisers did their utmost to bring the exhibition to fruition but in the end, in the words of Marco Vidotto, it was a tale of a 'sudden murder'.⁸⁸ Bruno Zevi, one of the three critics chosen for the scientific committee of the exhibition by the municipality of Siena, simply decided that it was not important: a major setback which sounded the death knell of the exhibition.

85 Szacka, 'Léa-Catherine Szacka in Conversation with Rem Koolhaas and Stefano de Martino.'

86 Szacka, 'Léa-Catherine Szacka in Conversation with Rem Koolhaas and Stefano de Martino.'

87 Marco Vidotto, 'Traces of a Birth and a Sudden Murder: Team 10's Sienna Exhibition and Meeting', in *Team 10 - Keeping the Language of Modern Architecture Alive*, ed. by Max Risselada, Dirk van den Heuvel, and Gijs de Waal (Faculty of Architecture Delft, 2006), pp. 210–21.

88 For details of the vicissitudes of the exhibition, see Vidotto, 'Traces of a Birth and a Sudden Murder: Team 10's Sienna Exhibition and Meeting.'

Finally, in the wake of Team 10's failed attempt to hold their exhibition in Siena, the young Italian architects Vidotto and Mazzini persevered with their idea of putting forward an alternative to the architecture inundating the media, but the focus then switched to the work of Alison and Peter Smithson. The outcome was the exhibition entitled 'Alison + Peter Smithson: A Celebratory Exhibition' inaugurated at the Palazzo Taverna, Rome in 1991.

Alison and Peter Smithson were not sure how much the Team 10 exhibition would be of interest to architects of a different generation, and became even more dubious when the theme shifted to focus exclusively on their own work. But ten years had already gone by since the 'La Presenza del Passato' at the Venice Biennial and the cultural and architectural backdrop had changed.

In the *Strada Novissima* the majority of people was supporting and endorsing the message of the exhibition. They thought they could assert a particular thing. [...] In this way, 1980 was the last time a kind of coherence emerged between architects; in 1988, this had become impossible.⁸⁹

As Rem Koolhaas pointed out, architectural discourse became highly fragmented after the exhibition 'Strada Novissima' – and in one of these niches there was once again room for Alison and Peter Smithson's thinking during the next decade.

Emergence and reflection

In the 1990s, several exhibitions about the Smithsons' work enabled them to recover some of their lost prominence.

'Alison + Peter Smithson: A Celebratory Exhibition' opened in Rome in 1991 at virtually the same time as the presentation of the monograph *A + P Smithson: pensieri, progetti e frammenti fino al 1990*, the first external compilation of their work since 'A Smithson File' by Jeremy Baker, published in the journal *Arena* in 1966. The aim of said monograph, also edited by Marco Vidotto, was to provide a potted history of the Smithsons' projects using, as far as possible, their words. The exhibition, however, was a personal re-interpretation by its curators: 'We told the story of reflections on the nature of architecture that still contemporary and concrete, non-ideological and non-rhetorical. We underlined a coherence and a freedom that is still intact.'⁹⁰

The exhibition was far more popular than expected at first, and travelled around Europe for more than 10 years: Istanbul, Ankara, Lund, Geneva, London, Stockholm, Zurich, Vienna, Edinburgh, Bath, Plymouth, Siena, Barcelona, Bilbao, Gijon, Cadiz, Valencia, Madrid, Seville, ...

Alison and Peter Smithson also gained prominence in 1990 on account of another exhibition, 'The Independent Group: Postwar Britain and the Aesthetics of Plenty', which involved the reconstruction of their 'Patio & Pavilion' twenty-five years after the original 'This is Tomorrow' held in 1956 at the Whitechapel Art Gallery in London. This reconstruction at the Institute of Contemporary Arts in 1990 cast

89 Szacka, 'Léa-Catherine Szacka in Conversation with Rem Koolhaas and Stefano de Martino.'

90 Marco Vidotto, A + P Smithson and Augusto Mazzini, *Alison + Peter Smithson Architects: A Celebratory Exhibition* (London: Docomomo UK, 1994). p.17.

the legacy of the Independent Group, together with its aims and importance in the post-war period, back into the limelight. The exhibition was a great success and toured important museums around the world from 1990 to 1991.⁹¹ The exhibition was accompanied by a book that provided the first comprehensive view of the Independent Group's achievements, complete with new insights and contributions, published by the acclaimed MIT Press.⁹²

This was followed by other travelling exhibitions including one entitled 'Climate Register: Four Projects by A + P Smithson' (1994), staged at the Architectural Association, curated by Lorenzo Wong and Peter Salter, and also accompanied by a monograph and the publication of Alison Smithson's *Imprint of India*;⁹³ and finally, 'From the House of the Future to the House of Today' (2003), also accompanied by an outstanding book and catalogue, and curated by Max Risselada and Dirk van den Heuvel, which was the outcome of long research at the Faculty of Architecture at Delft University of Technology, which was inaugurated at London's Design Museum and travelled for ten years until 2013.⁹⁴

All these exhibitions were, to use Peter Smithson's words, 'exhibitions of reflection', i.e., 'conscious acts of interpretation by others'⁹⁵ which addressed the Smithsons' multi-faceted thinking from different angles. They also enabled the Smithsons themselves to reflect upon their own work, and become aware, as happened after visiting the exhibition curated by Vidotto and Mazzini in Rome, of the persistence of their ideas and their 'set of mind' as they called it.⁹⁶

To the inventors of these reflections [...] we brought only the following thought – that an exhibition must not be like magazine pages stuck on a wall, but something used as a chance, like those earlier exhibitions, to operate in real space... making a simulacrum in miniature of the places built or depicted, so one can judge something of the quality of the real space, or gain something by the spatial commentary of the simulacrum.⁹⁷

Peter Smithson's third version of 'Staging the Possible', drew attention once again to exhibitions as a 'chance to operate in real space'. A chance that the Smithsons never failed to make the most of, a habit that persisted in their work in this phase of intellectual maturity too. The Smithsons were passive spectators in these exhibitions of reflection but, at the same time, they never ceased to conduct their own laboratory experiments in the new exhibitions of emergence.

91 Instituto Valenciano de Arte Moderno (Valencia), The Museum of Contemporary Art (Los Angeles), University Art Museum (Berkeley), and the Hood Museum of Art (New Hampshire).

92 David Robbins, *The Independent Group: Postwar Britain and the Aesthetics of Plenty* (MIT Press, 1990).

93 Lorenzo Wong and Peter Salter, eds., *Climate Register: Four Works by Alison & Peter Smithson*, (London: Architectural Association, 1994).
Alison Smithson, *Imprint of India* (London: Architectural Association, 1994).

94 Dirk van den Heuvel and Max Risselada, eds., *Alison and Peter Smithson - From the House of the Future to a House of Today* (Rotterdam: 010 Publishers, 2004).

95 Peter Smithson, 'Restaging the Possible.'

96 These thoughts are put forward in 'Set of Mind', Smithson and Smithson, *Italian Thoughts*.

97 Peter Smithson, 'Restaging the Possible.'

And on they went, throughout their lives, experimenting with the interplay between the ephemeral and the permanent, between emergence and reflection, working unceasingly on

...an architecture to be continually first staged then built...⁹⁸

....

The research set forth in this PhD thesis from this point onwards will focus on the crucial year discovered in the collage, 1981, and then proceed to reveal the valuable thoughts conveyed by Alison and Peter Smithson in their exhibitions.

Firstly, in the group of Christmas exhibitions staged between 1976 and 1981, after the Smithsons vanished from the London scene, and when the revision they conducted of their own work in parallel enabled them to refine their thinking and produce a new architectural discourse which they presented, after reinterpreting it, in *The Shift*.

Secondly, in the series of TECTA exhibitions which began in 1981 when they met Axel Bruchhäuser and began a close partnership which was to last more than twenty years. A long period characterized more than any other by the unfettered and unconditional experimentation and implementation of their thinking. A final period which constitutes their most precious intellectual legacy.

98 'Staging the Possible' Smithson and Smithson, *Italian Thoughts*.

Exhibitions by Alison and Peter Smithson

- A+PS **Parallel of Life and Art**
(with Nigel Henderson, Eduardo Paolozzi and Ronald Jenkins) Institute of Contemporary Arts, London.
11 September - 18 October 1953
- AS **Hot Springs**
Ascot Water Heater Exhibition stand. Olympia, London. 27 May - 8 July 1955 (competition, not held)
- A+PS **The City by Day, The City by Night**
Turn Again Exhibition. Royal Exchange, London. 12 - 30 July 1955
- AS **House of the Future**
Daily Mail Ideal Home Exhibition. Olympia, London. 5 - 31 March 1956
Waverley Market, Edinburgh. 29 June - 14 July 1956
- A+PS **Patio and Pavilion**
(with Nigel Henderson and Eduardo Paolozzi) *This is Tomorrow exhibition*. Whitechapel Art Gallery,
London. 9 August - 9 September 1956
- PS **Drawings by Peter Smithson**
Library of the Institute of Contemporary Arts, London. 4 - 28 June 1958
- A+PS **Extensions of Man (or N.M.A Exhibition)**
1962 (exhibition not held)
- AS **Painting and Sculpture of a Decade, 1954-64**
Gulbenkian Exhibition. Tate Gallery, London. 22 April - 28 June 1964
- AS **Wedding in the city**
Il Grande Numero, Fourteenth Triennial, Milan. 30 May - 28 July 1968
- A+PS **A Line of Trees... A Steel Structure**
Art Net Gallery, London. October 1975
Net Works Edinburgh. Fruitmarket Gallery, Edinburgh. 7 - 28 February 1976
- A+PS **The Tram Rats**
The Rally: Forty London Architects. Art Net Gallery, London. 5-14 July 1976
- AS **Sticks and Stones**
Europa/America. Architettura urbana/alternative suburbana, Venice Biennial, Venice. 14 July - 10
October 1976
- PS **Family of furniture**
Interdesign 2000 Furniture Competition Exhibition. Institute of Contemporary Arts, London (Summer
Studio Program). 1973
- AS **The Entrance Made Festive**
'Signs of Occupancy' Seminar. Bartlett School of Architecture, London. Period before Christmas, 1976
- A+PS **Art into Landscape: Swinging Elland (AS), Kingsbury Lookouts (AS), Tees Pudding (PS), The
Slaggie Eleven of the Spenny Moor Slag Heaps (AS), Skateboard Junction (AS), Kelvingrove Art
Gallery and Museum Approach (PS)**
Serpentine Gallery, London. 16 July - August 1977
Middlesborough Art Gallery, London. 20 - 31 August 1977
- AS **Twenty-Four Doors to Christmas**
Kettle's Yard, University of Cambridge. 24 November - 23 December 1979

- AS **Christmas & Hogmanay**
The Fruitmarket Gallery, Edinburgh. 17 December 1980 - 17 January 1981
- AS **Der Berlinerbaum (In memoriam Kongreßhalle Berlin)**
Aedes Gallery, Berlin. 6 November 1980 - 17 January 1981
- AS **Come Deck the Hall**
35 King Street Gallery, Bristol. 1981 (exhibition not held)
- AS **Concentricity Update**
Storefront for Art and Architecture, New York. 13 September - 7 October 1984
- A+PS **Cologne International Furniture Fair**
International Furniture Fair. Cologne. 17 - 22 January 1984
- A+PS **10 Years of Stefan Wewerka in TECTA, 1975-1985**
Wewerka-Pavilion Exhibition. TECTA Factory, Lauenförde. 7 September 1985
- AS **The Future of Furniture - Furniture of the 4th Generation**
International Furniture Fair. Milan. 17 - 22 September 1986
- A+PS **Triangle Artists' Workshop**
The Triangle Arts Association, Pine Plains, New York. 1987
- AS **Saint Jerome: The Desert – The Study**
International Furniture Fair. Milan. 12 - 17 April 1991
- A+PS **Speaking to the Sky**
University of Witwatersrand, Johannesburg. 1991
- AS **Modern Architecture Has Been with Us for Four Generations**
International Furniture Fair. Cologne. 21 - 26 January 1992
- AS **TischleinDeckDich a.s.o.**
Mautsch Gallery, Cologne (with Hexenhaus photo exhibition). 16 - 31 January 1993
Aedes Gallery, Berlin. 15 February - 15 March 1993
- PS **Cologne International Furniture Fair**
International Furniture Fair. Cologne. 17 - 22 January 1995
- PS **On the Floor Off the Floor**
Mautsch Gallery, Cologne. 19 January - 28 February 1998
- PS **La Ville en Jeux / Toy Town**
Canadian Centre for Architecture, Montreal. 22 October 1997 - 31 May 1998
- PS **Lattice Furniture Stand**
International Furniture Fair. Cologne. 18 - 24 January 1999
- PS **Popova's Chair Exhibition**
International Furniture Fair. Cologne. 17 - 23 January 2000
- PS **Flying Furniture**
StuhlMuseum, Burg Beverungen. 29 January - 30 April 2000

Christmas Exhibitions

The Entrance Made Festive (1976)

Twenty-Four Doors to Christmas (1979)

Christmas & Hogmanay (1980-81)

Come Deck the Hall (1981)



1 Smithsons' Christmas Tree, 1976.

'is the story of a little Boy who was born long ago in a faraway village in a stable.'¹

Christmas, and specifically the popular traditions that go hand in hand with this celebration, is the theme running through a series of exhibitions held by Alison Smithson between 1976 and 1981. Christmas was in fact the vehicle she chose to convey her concern about the urgent need to renew the sense of collective responsibility for the look and use of places.

At Christmas, this pattern of collective appropriation – of both private and shared spaces – arises almost spontaneously because it is the outcome of a series of traditions handed down from one generation to the next over a long period of time. The parallelism of Christmas makes it a good example upon which to reflect whilst its great versatility enables it to spread its message amongst a far broader audience.

From this viewpoint, these exhibitions served to disseminate her ideas, but for the Smithsons they were also an opportunity to find and try out a form of receptive architecture able to act as support for a renewed 'art of inhabitation'. The Christmas exhibitions also coincided with a doldrums period in which they failed to materialise any projects, after completing the Robin Hood Gardens in 1972, and now became the ideal laboratory in which to continue reflecting upon and experimenting with transient materials but in real space.

The four exhibitions examined here are not individual entities with different approaches but cumulative parts of the same research project which, if studied separately, might result in incomplete findings. They are different moments in a single process. The materials produced and the experience gained from each exhibition provided the basis for developing the next one. They could be said to be different reiterations testing the same initial hypothesis over and over in different contexts but with greater degrees of freedom. A process that began entirely in the academic world, as part of a seminar at Bartlett School, with 'The Entrance Made Festive', which would, if it had taken place, have culminated in a public participation event in Bristol according to the exhibition project drafted by Alison Smithson for 'Come Deck the Hall'.

1 Alison Smithson, *Calendar of Christmas*.



2 Christmas Cards, 1976.

The Entrance Made Festive

Alison Smithson

1976 – 1977

Venue and dates: Entrance of the Bartlett School of Architecture, University College, London. Period before Christmas, 1976.

Organizers: Alison Smithson and Peter Smithson.

Design: Alison Smithson and Peter Smithson.

Work team: Students at the Bartlett School of Architecture, University College, London.

Gross floor area: -

Itinerary: None.

Exhibition catalogue: None.

Related publications:

Alison Smithson, *The Christmas Tree* (London, 1976).

Alison Smithson, *Calendar of Christmas* (London, 1976).

Additional information: Part of the 'Signs of Occupancy' seminar (Peter Smithson, Banister Fletcher Professorship).

Reviews: -

Sir Banister 'Flight' Fletcher (1866–1953) was an English architect and architectural historian. Together with his father, also called Banister Fletcher, he co-authored the textbook *A History of Architecture on the Comparative Method* (London, Athlone Press, University of London, 1896). In his will, he left a bequest to the Bartlett School of Architecture to provide funds for an academic chair in architecture, the Banister Fletcher Professorship, which still exists today. In the 1976-77 academic year, this chair was occupied by Peter Smithson. It was at this time, in the period before Christmas 1976 to be precise, that the installation-exhibition 'The Entrance Made Festive' arose as part of the seminar 'Signs of Occupancy', a seminar about the nature of the public domain, its renewal and its decoration, which was a new opportunity to put into practice the reflection begun almost ten years earlier with the 'Wedding in the City' exhibition.

As part of the seminar, the 'The Entrance Made Festive' exhibition used Christmas – which the Smithsons considered to be 'the last surviving popular festival: an event which exercises the imagination of entire populations'² – as an excuse to invite Bartlett School students to decorate their school's entrance in a practical exercise of collective occupancy – an opportunity not only to experience first hand how an object can renew a place, and but also to demonstrate how occupancy can be an art.

In support of the seminar, Alison Smithson prepared and edited two documents that compiled the materials of research which, in her own words, took place over four years (1972-1976). The two documents were 'The Christmas Tree' and 'Calendar of Christmas'.³

In the introduction to both documents, Alison tells the reader that they are not scholarship works and therefore 'the source material has been handled fairly freely'.⁴ Her research is, however, well documented – quoting more than fifty different sources – and is not circumscribed to the British context but gives a very broad view of the different ways Christmas is celebrated around the globe. The intention is to make the reader aware of the customs that have gradually shaped the popular, collective event known as Christmas time. Knowing the origin of all these traditions makes it possible to understand how 'the spirit of the event has been sustained by continuous invention, adoption, and borrowing of ideas, imagery and feelings'.⁵ In short, the documentation compiled in these two documents shows Christmas to be an on-going, collective exercise of decorating and renewing the public and private domain.

The Christmas Tree

This is the first of the two documents presented in support of the seminar. Once again, as in many of her previous and subsequent essays, proposals, ideas, etc., the tree

2 Alison Smithson, *Calendar of Christmas*.

3 The covers of both documents are an adaptation of a 1953 collage featuring a pair of photographs: hamlet/village, town/city, according to Alison Smithson and Peter Smithson, *Alison + Peter Smithson: The Shift*, Architectural Monographs (London: Academy Editions, 1982), p.56.

4 Alison Smithson, *Calendar of Christmas*.

5 Ibid.

is the starting point. Nature is never far from their thoughts but not in a metaphorical or figurative sense, but as a specific element that contributes its own character and content to the discourse.⁶

In the case of Christmas, ‘two traditions were given new life by the universal adoption in the nineteenth century of the fir Christmas tree: the use of evergreens as symbolic decoration; the use of candlelight to ward off the spirits of darkness.’⁷

The use of evergreens as decoration harks back to the pagan origin of Christmas: the Roman Saturnalia. The adoption by Christians of Saturnalia greenery (box, juniper and laurel to dress the inside and the outside of the house) afforded concealment: ‘evergreens as a celebratory mantle: evergreens as warding off antagonistic forces’.⁸

Candles have a more spiritual origin in remembrance of the gift of light, ‘representing the coming of the Light of the World in the birth of Christ’,⁹ but were already part of the Roman Saturnalia tradition in which candles were given as auspicious gifts.

Things pagan and religious, bodily and spiritual, green and red, the different facets of Christmas brought together by collectivity in the course of history by the advent of the Christmas tree as an object of renewal.

Calendar of Christmas

This is the second of the two documents presented in support of the seminar.

Christmas is not a single feast day but a time of year that varies in length depending on the different traditions, a period of time known as Christmas time. It is particularly a time of expectancy, a period during which a variety of celebrations gradually prepare us for festivities and make us collectively aware of each moment we experience: ‘anticipations of new feelings, echoes of deep old ones, run through most of us at Christmas time.’¹⁰

This second document analyses chronologically all the milestones in the calendar related to the celebration of Christmas – St Nicholas’ Feast, St Lucia’s Day, St Thomas’ Feast, Twelve Days, Boxing Day, December 28th, New Year’s Eve, Epiphany, Candlemas, etc.

All this research begins with the origin of the meaning of Christmas:

The names given to the feast by different European peoples throw a certain amount of light on its history. Let us take five of them – CHRISTMAS, WEIHNACHT, NOEL, CALENDAS and YULE – and see what they suggest.

6 To mention but a few of these instances, the book *Alison + Peter Smithson: The Shift* opens with the article ‘The Tree of Enquiry’; St Hilda’s College and the Upper Lawn Pavilion are inconceivable without their trees; the House of the Future has a tree encapsulated in its patio despite being indoors; The Wayland Young Pavilion is built around a tree; The Yellow House with a tree-shaded spot for gathering around, etc.

7 Alison Smithson, *The Christmas Tree*.

8 Ibid.

9 Ibid.

10 Alison Smithson, *Calendar of Christmas*.

The English CHRISTMAS and its Dutch equivalent KERSTMISSE plainly point to the ecclesiastical side of the festival; the German WEIHNACHT (sacred night) is vaguer, and might well be either pagan or Christian. [...]

The French NOEL [...] Provençal NADAU or NADAL, the Italian NATALE, and the Welsh NADOLIG, all obviously derived from the Latin meaning 'birthday'.

The Provençal CALENDAS or CALENOS, the Polish KOLENDA, the Russian KOLYADA, the Czech KOTEDA [...] are all derived from the Latin KALENDAE, and suggest the connection of Christmas with the Roman New Year's Day.

YULE (Danish JUL), is the ordinary word for Christmas in the Scandinavian languages [...] it is clearly the name of a Germanic season.⁴⁴

In short, these two documents condense four years of research and contain the seed, the theoretical, historical and cultural corpus about Christmas that was to provide the documentary support for the occupancy exercise put forward in the Bartlett School seminar of 1976, and were also to be the benchmark, inspiration and the basis for the contents that were to make this series of Christmas exhibitions possible.

11 Ibid.



3 The covers of each document are based on Christmas cards made by the Smithsons for Christmas 1975 which were in turn based on a previous collage. A kind of fresh life for the past 'as found'. 'Signs of Occupancy at Christmas: re-work of collage of 1953, a pair of photographs (people received one or the other) hamlet/village, town/city.'

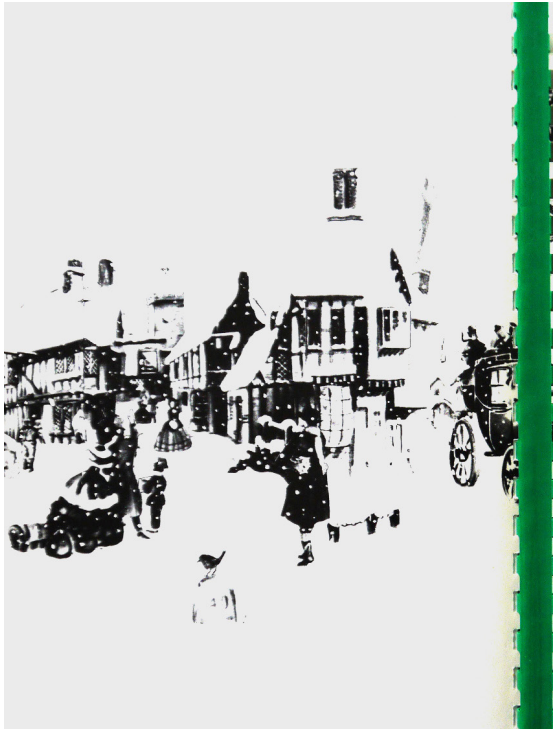

14

Advent of the Tree as Christmas Object

Legend has it St. Boniface gave the Christmas tree to his Germanic converts as substitute for their oak ... this is supposed to have taken place during the eighth century, a supposition based on a letter to the Pope in 742 on the problem of lurid festivals of Franks and Alemans. Another German tradition of the origin of tree as Christmas object is the Paradiesbaum: the Paradise Tree of German mystery plays. This has been described as a fir tree hung with apples, ringed around with lighted candles, representing the Garden of Eden. In the fifteenth century, the Paradiesbaum is described as being decked with white wafers symbolizing Holy Eucharist, the body of Christ, the coming Saviour: often made by religious houses, the use of wafers is still connected with Christmas in Poland. This fir tree of the Paradise Play is then said to have been taken into the home, adopted for family use after the custom of the Play - performed inside or just outside a church - lapsed: later, wafers replaced by pieces of pastry cut into stars, angels, hearts, flowers and bells, and figures of Adam and Eve. In mid-seventeenth century, candles became part of tree decoration, representing starry heavens among other traditions; glittering decorations were also added. At first these were only found in Valley of Upper Rhine, but gradually became popular in other parts of Germany. The tree's universal acceptance in the nineteenth century was prepared for by German stories of other happenings:

One Christmas Eve, long ago, says one of their legends, the dark wind and the white snow howled and drove about a forester's cottage, deep in the midst of tall trees. Inside, the forester and his family were warm and snug and thankful; when a tiny knock came on the door. Startled, the forester arose quickly and opened it. There stood a small child, cold, exhausted, hungry. Quickly they took him in and shut out the storm. They warmed him by the fire, and fed him their goodly, plain food, and put him in their cosiest bed.

The morning broke in a dazzling white such as they had never seen before. The angel choir had returned, with its great music which reached down to shepherds and cottagers.

The Child stood before them, radiant now. He said, "There is nothing I can give you beyond what you already have, except one thing." From a fir tree he broke off a branch and planted it by the door. Straightway it blossomed. "Behold," he said, "my gift to you. Henceforth it shall always bear its fruits at Christmastide, when all the world is empty and dead. To you it shall be a sign of faith that does not die." § 1

Martin Luther is supposed to have had the first tree:

Martin Luther was out walking one night, and the stars suggested to him lights, which he then placed upon a fir tree to brighten the Christmas of his son. § 1

In Bethnal Green Museum there is an eighteenth century toy model room containing Luther and his family together with Neianthion; on their table is a Christmas tree.

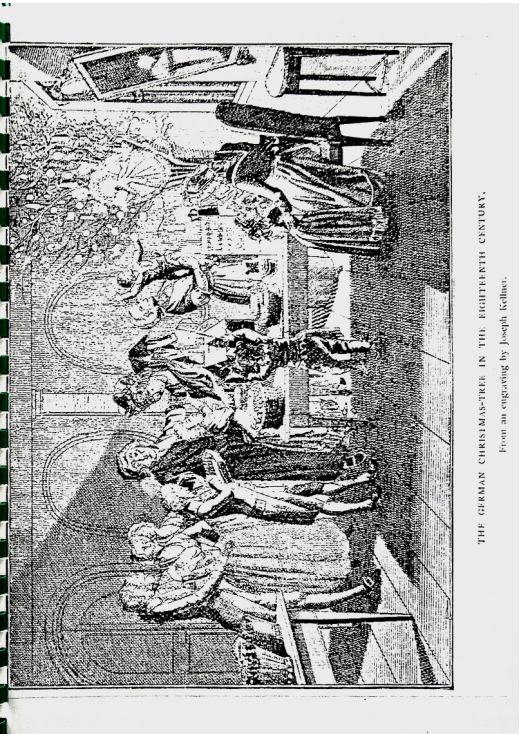

THE GERMAN CHRISTMAS-TREE IN THE EIGHTEENTH CENTURY.
From an engraving by Joseph Kolber.

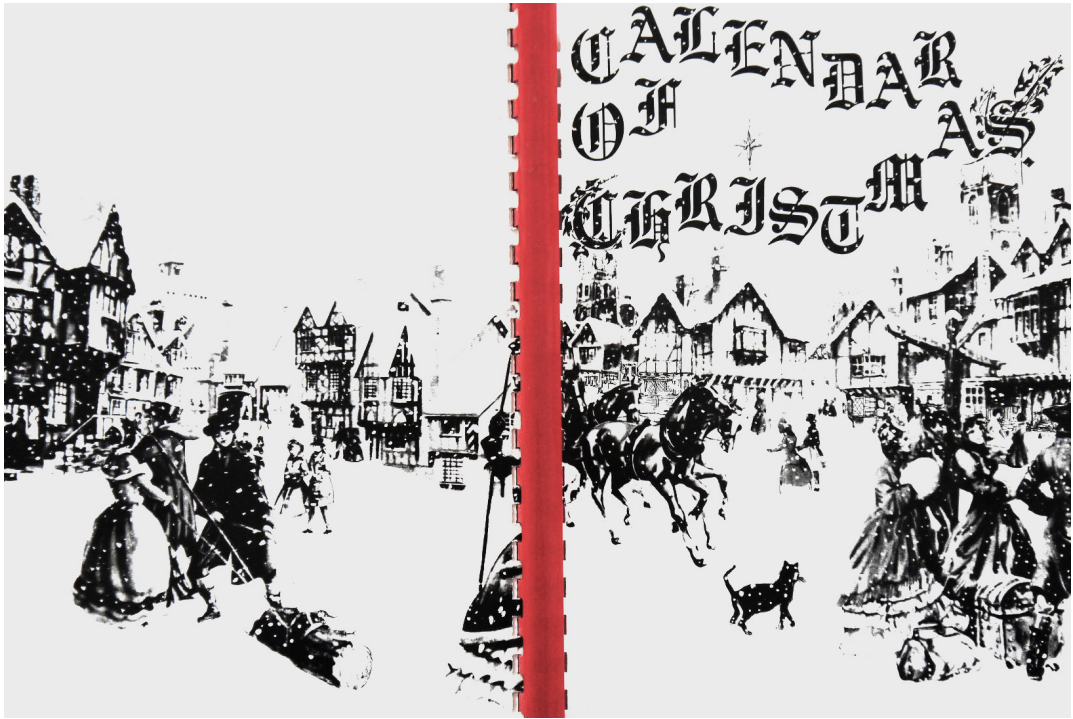

CALENDAR OF CHRISTMAS

CALENDAR OF CHRISTMAS

LIST OF CONTENTS

	No. of pages
Introduction	1
Spirit or Sense of Christmas	9
Spirit personage of Christmas	6
Advent	4
Crèche	4
December	1
December 4	1
St Nicholas Eve	3
Festival of St Nicholas	1
December 8	1
The Night of Lucy	1
St Lucia's Day	2
December 15	1
December 17	1
December 18	1
St Thomas's Eve	1
St Thomas's Feast	3
Yule	4
December 23	1
Christkindl	2
Christmas Eve	8
Christmas Day	6
Twelve Days	3
Mummers	3
Boxing Day	3
Gooding Day	1
December 28	1
New Year's Eve	7
New Year's Day	5
New Year's Morrow	1
Epiphany Eve	1
Twelfth Night	4
Sunday after Epiphany	1
Monday after Epiphany	1
January 7	1
January 11	1
January 14	1
January 17	1
Aphelli	1
Candlemas	1

CHRISTMAS:

is the story of a little boy who was born long ago in a faraway village in a stable. 5-14

EUROPE

The names given to the feast by different European peoples form a certain amount of light on its history. Let us take five of them - CHRISTMAS, WEIHNACHT, ROLL, CALENDAS, and YULE - and see what they suggest.

I. The English CHRISTMAS and its Dutch equivalent KERSTMISSE plainly point to the ecclesiastical side of the festival; the German WEIHNACHT (sacred night) is vaguer, and might well be - some pagan or Christian, in point of fact it seems to be Christian, since it does not appear till the year 1000, when the faith was well established in Germany.

The first mention of a Nativity feast on December 25 is found in a Roman document known as the Philocalian Calendar, dating from the year 354, but embodying an older document evidently belonging to the year 136. It is uncertain to which date the Nativity reference belongs; but further back than 336 at all events the festival cannot be traced.

Whether it came to England through the Celtic Church is uncertain, but St. Augustine certainly brought it with him, and Christmas Day, 597, witnessed a great event, the baptism of more than ten thousand English converts. In 367 the Council of Tours had declared the Twelve Days, from Christmas to Epiphany, a festal tide; the laws of Ethelred (931-1016) ordained it to be a time of peace and concord among Christian men, whom all strife must cease. In Germany Christmas was established by the Synod of Mainz in 811; in Norway by King Hakon the Good about the middle of the tenth century.

II. The French YULE is a name concerning whose origin there has been considerable dispute; there can, however, be little doubt that it is the same word as the Provencal SASAU or NABAL, the Italian NATAL, and the Welsh NADULU, all obviously derived from the Latin meaning "birthday."

THE DIES NATALIS INVICTI was probably first celebrated in Rome by order of the Emperor Aurelian (270-5); SOL INVICTUS was identified with the figure of Mithra.

III. The Provencal CALENDAS or CALNOS, the Polish KOLENDA, the Russian KOLYADA, the Czech KUTERA and the Elizabethan KALEDOS, not to speak of the Welsh CALENIC for Christmas-box, the Gaelic GALLANIG for New Year's Eve, are all derived from the Latin KALENDAR, and suggest the connection of Christmas with the Roman New Year's Day, the Kalends or the first day of January, a time celebrated with many festive customs.

IV. YULE (Danish JUL), is the ordinary word for Christmas in the Scandinavian languages, and is not extinct among ourselves. Whatever its source may be, it is clearly the name of a Germanic season - probably a two-month tide covering the second half of November, the whole of December, and the first half of January (21st). 2-7

6 and 7 Calendar of Christmas. Cover and list of contents showing all the events analysed in the publication and the start of the briefing document.

THE SPIRIT PERSONAGE OF CHRISTMAS: FATHER CHRISTMAS : SANTA CLAUS : ST. NICHOLAS : KRIS KRINGLE

At one time synonymous with Spirit of Winter.

SCANDINAVIA
May have origin in Oden or Woden. Legend has him King of Sweden, aged, bearded, single all-seeing eye, noble bearing, dressed in blue, ruddy bro' dark Arctic winters, on a white eight footed steed called Sleipner.

ENGLAND
In James I, Father Christmas,
Wellcome or welcome met,
I hope red Father Christmas
Will never be forgot.

AMERICA
By the 17th century the Feast of Sinterklaas introduced by Dutch settlers to New World where his image later merged with British Father Christmas, to become Santa Claus living at the North Pole, driving Reindeers. S 24
Sleigh believed drawn by mountain goats.

ENGLAND
Very old grey bearded gentlemen called Christmas.

FURITAN DAYS
Recent research by Jones indicated that Washington Irving's KISICKERBOCKER'S HISTORY (1809) provided much of the lore of Santa Claus's visit which was to become current in the next decade and which was probably known to Moore by 1822. Jones also points out that an 1822 issue of THE CHILDREN'S FRIEND, published in New York City, contained colored engravings of "Santeclaus" and verso which refers to his rosinber and sleigh. These may have been the sources of some of the fancies which Moore employed in his now famous poem. S 18

AMERICA
Santa Claus in the 1820's travelled on foot, or in wagon, dressed wholly in fur.
Rev. Clement Clarke Moore - "Night before Xmas" picked up reindeer from Lapland version of St. Nicholas's transport. Illustrators replaced holly wreath by fur edged cap. i.e. Night before Christmas "Jolly wee elf".
Not long after the publication of Moore's "A Visit from St. Nicholas", a number of American artists began to portray the emerging figure of Santa Claus. These pictures varied greatly until the time of Thomas Nast. An early portrayal of Santa Claus by Sherman and Smith appeared in a New York City magazine in 1841. This engraving depicted him sitting by a fireplace putting toys in children's stockings. He was small, dressed in a fur coat and wore a clove-hatting cap on which a bishop's cross appeared. He also smoked a small Dutch pipe and had a pleasant but not a jovial expression. The caption under the picture, "Santa Claus the Night before New Year", indicated that gift bringing on days other than December 24th and 25th persisted in New York City at least until 1843.
Some doubt is entertained by specialists that the Sherman and Smith drawing precedes the American Santa Claus. Woltzenkamp believes that a drawing by J.G. Chapman in 1847 provided the first embodiment of the modern Santa Claus. This Santa Claus was large, wore fur-trimmed clothes, high boots, and a feather in his cap. Woltzenkamp also points out that various Santa Claus illustrators of the nineteenth century failed to agree on his attributes. For instance,

S 18 # continued.....



CRÛCHE : OR CHRISTMAS CRIB

EUROPE
Luther's lullaby: Away in a manger
Away in a manger,
No crib for his bed,
The little Lord Jesus
Lay down His sweet head;
The stars in the heavens (bright sky)
Look'd down where He lay;
The little Lord Jesus,
Asleep in the hay.
The cattle are lowing,
The poor baby wailing,
But little Lord Jesus
No crying He makes!
I love Thee, Lord Jesus,
Look down from the sky,
And stay by my crib
Watching my lullaby. S 1
Crèches begin to appear in churches for the First Sunday in Advent, in England, usually in the Children's Corner.
In the late 1820's and early 1830's mechanized Christmas scenes were still displayed in Christmas Crèches in the toy or sports departments of local department stores; these were derived from the original shows. It is probable that Disney caused all trace of the intended delicate magic of these snowy landscapes, peopled by miniature figures, and often including the Holy Family, to be lost.

SICILY
The whole tradition of mechanized Christmas scenes came with the musical box skills of the Italians into Europe - like Punch and Judy - the shows were built, carried around, and manipulated by Italians in the 18th and the 19th centuries; and perhaps 17th century. S 3

ITALY
The institution of the PRESEPIO is often ascribed to St. Francis of Assisi, who in the year 1224 celebrated Christmas at Greccio with a Bethlehem scene with a real ox and ass. He visited the east in 1219-20, and the Greccio celebration took place in 1224. St. Francis and his followers may well have helped greatly to popularize the use of the PRESEPIO, but it can be traced back far earlier than their time. In the liturgical drama known as the "Officium Pastorem", which probably took shape in the eleventh century, we find a PRESEPIO behind the altar as the centre of the action; but long before this something of the kind seems to have been in existence in the church of Santa Maria Maggiore in Rome - at one time called "Santa Maria ad Praesepe".
According to Usener's views this church was founded by Pope Liberius (352-66), and was intended to provide a special home for the new festival of Christmas introduced by him, while an important part of the early Christmas ritual there was the celebration of Mass over a "manger" in which the consecrated host was laid, as once the body of the holy child in the crib at Bethlehem. Further, an eastern homily of the late fourth century suggests that the preacher had before his eyes a representation of the Nativity. S 2

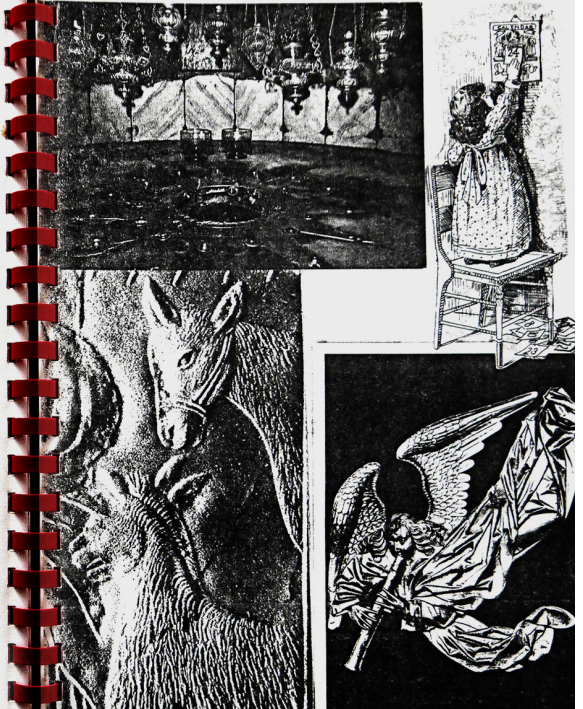

KETTLE'S YARD NORTHAMPTON ST. CAMBRIDGE



TO CHRISTMAS

24 NOVEMBER TILL 23 DECEMBER

MONDAY - SATURDAY 12.00-6.00 SUNDAY 2.00-6.00 ADMISSION FREE
WITH THE SUPPORT OF THE ARTS COUNCIL OF GREAT BRITAIN

Printed by Graphic Art (Cambridge) Ltd.

blitz

10 Poster of the exhibition 'Twenty-Four Doors to Christmas'.

Twenty-Four Doors to Christmas

Alison Smithson

1979

Venue and dates: Kettle's Yard, University of Cambridge. 24 November – 23 December 1979.

Organizers: Kettle's Yard, University of Cambridge (with support from Arts Council of Great Britain).

Design: Alison Smithson. Spring – Christmas, 1979.

Curator: Jeremy Lewison (curator of Kettle's Yard) and Alison Smithson.

Construction team: Simon Smithson, Caroline Pitt, John Hare.

Work team: 6th year students of Professor Happold and Professor Brawne of the Department of Architecture and Building Engineering, University of Bath. (For complete list, see exhibition catalogue).

Gross floor area: 100 sq.m.

Itinerary: None.

Exhibition catalogue:

Alison Smithson and Jeremy Lewison, 'Twenty-Four Doors to Christmas' (Cambridge: University of Cambridge, 1979).

Related publication:

Alison Smithson, *An Anthology of Christmas*, 1979.

Additional information:

Construction of the framework together with University of Bath students as part of their autumn term's work.

Reviews:

Caryll Faraldi, 'No Title,' *Observer*, 9 December 1979.

Frank Whitford 'Christmas remembered...', *Cambridge Evening News*, 10 December 1979.

Astragal '24 Doors to Christmas,' *The Architects' Journal*, 12 December 1979.

Michael Jeffels, 'Shape of Things to Come,' *Architects' Journal*, 171 (9 January 1980).

Alison Smithson, '24 Doors to Christmas,' *Architectural Design*, November-December, 1980, pp. 177–78.

In the 1930s, Swedish charitable organisations, as a means of raising funds, introduced the Advent Calendar of 24 little doors bearing the dates in December up to Christmas Eve.¹²

The 'Twenty-Four Doors to Christmas' exhibition, as its title suggests, features twenty-four doors each concealing an interpretation of one of twenty-four aspects that contributed to the development of Christmas in England. The exhibition was presented to the public as a three-dimensional advent calendar that visitors could walk through and inhabit. The device of discovering behind each door a display that illustrates a different aspect of Christmas – and particularly the anticipation this causes – is borrowed from advent calendars. The aspects of Christmas chosen were:

1. The Nativity Stall: Christmas Market Stall
2. Carols: Shawm or wait,¹³ Christmas tree baubles
3. Spirits
4. Saturnalia: *vesicapiscis* or Christmas fishes [*sic*]
5. Season
6. Yule fire and Christmas stocking, Christmas gifts, Christmas wrapping of gifts
7. Feasting
8. Mumming¹⁴
9. Light
10. Bible
11. Contrived seasonal noise: wassailing, the Christmas cracker
12. Decorations: evergreen, kissing ring, paper decorations
13. The figure of Christian Charity
14. Christ's or Christmas bread: the Christmas wafer, *oplatek*, *yule doo*, straw
15. Family celebration: the Reformation: Melanchthon and Luther
16. Christianity: Nativity
17. Glad Tidings / Greetings
18. The Christmas Pantomime
19. Plenty
20. Charity
21. Personages of Christmas
22. Expectancy
23. Twelfth Night
24. The Renewal of Christmas

The exhibition's intention in bringing all these elements together in the period before Christmas in 1979 is clearly defined by the opening words of the exhibition catalogue: 'The exhibition Twenty-Four Doors to Christmas aims to encourage a

12 Alison Smithson and Jeremy Lewison, 'Twenty-four Doors to Christmas' (Cambridge: University of Cambridge, 1979).

13 Shawm or wait: medieval woodwind instrument.

14 A type of folk play performed by mummers (persons in disguise) that combines music and dance.

renewal of our arts of inhabitation.’¹⁵

The ‘decoration by events’ theme appears once again, as in the ‘The Entrance Made Festive’, but in this instance in a more specific and yet broader manner: the research is limited to the realm of English culture but is presented to a far more varied audience. Although the exhibition was possible thanks to university help – the Kettle’s Yard gallery belongs to Cambridge University and students from the Department of Architecture and Building Engineering at the University of Bath helped set up the installations – it is intended for people of all ages and walks of life but particularly for children, as indeed most Christmas events are. The children of today and also the child each person used to be are invited to join in the collective spirit of Christmas that the exhibition aims to awaken. As Frank Whitford’s review for the *Cambridge Evening News* pointed out:

What I like about these arrangements of Christmas memorabilia is that they do cause the embers of childhood memories once again to glow. This is partly because they cleverly combine objects that are both old and new, tawdry and expensive, cheap and luxurious. An antique shawm stands by a plastic kazoo.

V1: Decorations

Alison’s starting point when designing the exhibition – obviously a continuation of the installation created three years earlier – was to occupy and transform space, i.e. the small Kettle’s Yard gallery, by means of the actual items on display.

Items of different provenances – exhibits lent by diverse people and institutions: museums, universities, shops, libraries, foundations, individuals, etc.¹⁶ – were meticulously selected to awaken a feeling of collective achievement. In the first version of the project (fig. 11), the only items drawn on the bare axonometric projection of the hall are the boundaries of the gallery, the exhibits, and a few trees, drapes and swags that help complete and unify the exhibition.¹⁷ The support of the exhibition is coincident with its content. The atmosphere of the gallery is transformed simply by the exhibits and colour: lots of red, green, white, a little blue, silver, gold, etc.

This first version features a timid, initial reference to the advent calendar but as just another item in the exhibition. The words ‘25 brown doors in green wall’ can be seen on one of the walls in the hall.

15 A Smithson and Lewison.

16 For complete list, see exhibition catalogue (Alison Smithson and Lewison).

17 After studying all the available documentation about the project, the author believes there to be three versions of the project which are not, however, alternatives but different phases in the design process.

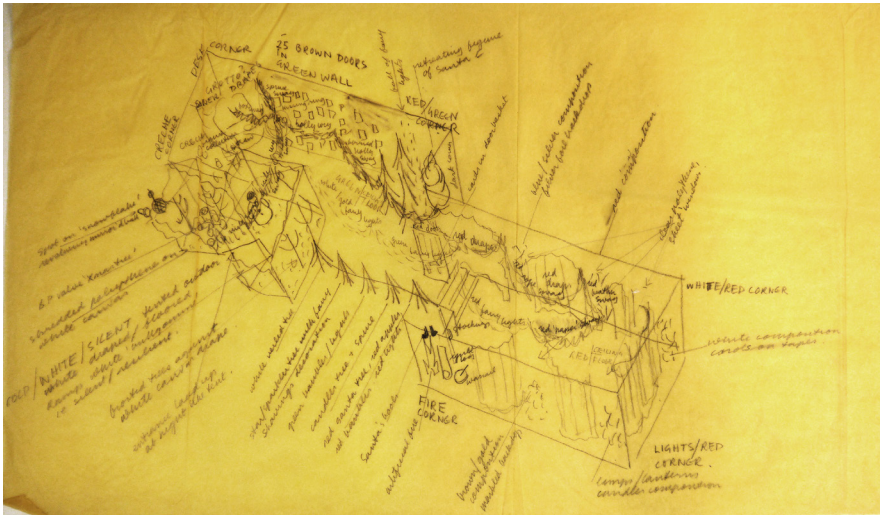

11 Preliminary drawing (V1: Decorations). AS, 1979.

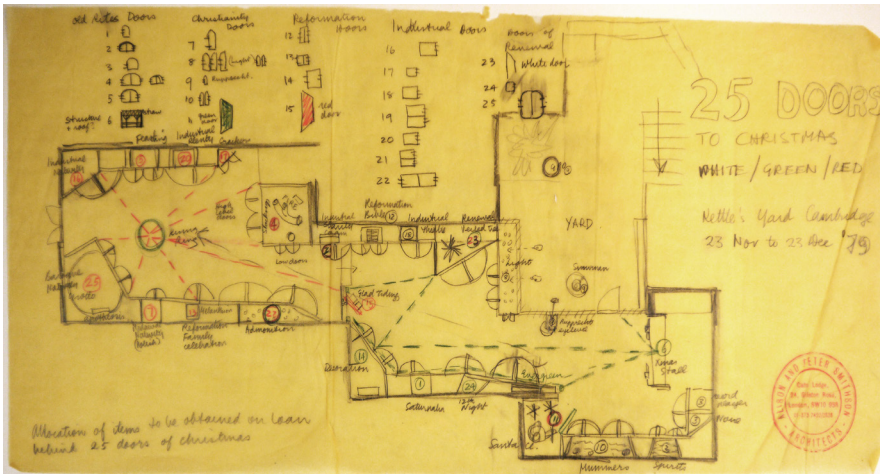

12 Preliminary drawing (V2: Doors). AS, 1979.

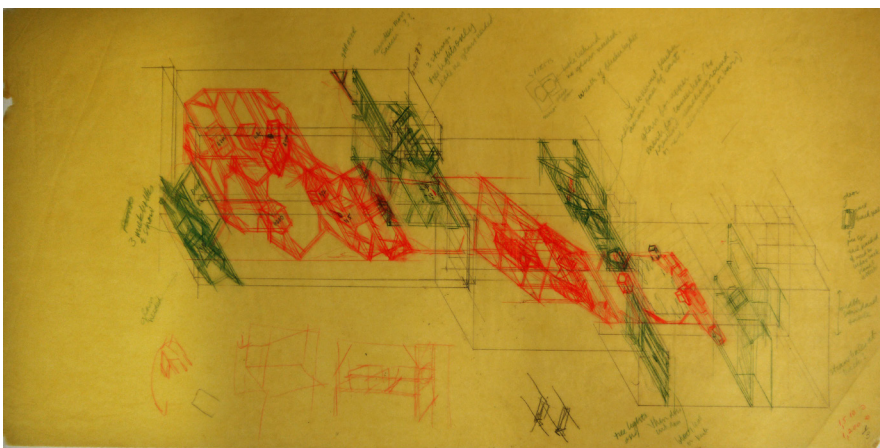

13 Preliminary drawing (V3: Lattice). AS, 1979.

V2: Doors

At later point in the design process, the idea of the advent calendar gains momentum. Certain elements now appear: the final title of the exhibition is now almost completely defined, '25 Doors to Christmas'; the time the exhibition will be open to the public i.e. the period of Advent; and a series of doors which are to conceal the items illustrating the selected aspects of Christmas. The doors suddenly appear and are now the main elements in the exhibition: the doors define the space and atmosphere created by the exhibition.

Cupboard doors are necessary to bring these miscellaneous contents to the right level of attention amongst the thousands of things that surround us [...]. Behind cupboard doors there can be secrets... concealed future pleasures. And the pleasures of anticipation are the sharpest of all.¹⁸

This quotation is taken not from the exhibition documentation but from the conference Peter Smithson gave at ILLA&UD in Urbino in the autumn of 1979 which began thus: 'This lecture came to me whilst standing in my bathroom thinking of nothing and facing six plain cupboard doors. [...] Suddenly I thought what a marvellous invention is the cupboard door. My lecture is therefore in praise of cupboard doors' – a reflection running parallel, curiously enough, to the design of the exhibition. The text of the conference was written between August and October 1979; the exhibition began to be designed in the spring of that year. Doors suddenly became key metaphors of the Smithsons' architectural thinking because different approximations and readings of the doors made many interpretations and approximations on different scales possible of the exhibition itself too: 'As the cupboard is to the house, so the house is to the town.'

The doors in the exhibition are 'as found' and can be classified into different thematic groups – old rite doors, Christianity doors, Reformation doors, industrial doors and doors of renewal – associated with different colours: green, red and white. A limited colour palette is used and the overall impression is simplified by the unity of the continuous backdrop defined by the doors. The geometry of the hall almost vanishes in the wake of this new spatial and physical envelope.

The general arrangement of the installation is similar in many respects to that of the 'Painting and Sculpture of a Decade' exhibition held at the Tate Gallery in 1964. The empty space accommodates the exhibits, enabling them to be viewed adequately. Some are inter-related and can be seen simultaneously whilst others must be viewed individually despite belonging to a single sequence of connected spaces. A look at the connections suggested by the dotted lines (fig. 12) reveals that there are two different moments in the circulation route: the green route leads visitors into the exhibition and gives them glimpses of the installation, whilst the red route enables them to understand the exhibition subsequently and enjoy it to the full.

18 Peter Smithson, 'In Praise of Cupboard Doors', *ILLA&UD Yearbook 1979*, 40–41. (p.40).

V3: Lattices

In a third phase of the design process, the framework becomes completely independent of the exhibition hall: the doors open up the perimeter and the exhibition shifts mainly into the centre area. An enabling frame emerges which can house the different doors and also the boxes intended to contain the miscellaneous objects selected for the exhibition. This structural framework consists of a group of timberwork lattices, painted red in the middle and green around the edge, that introduce variety and enable space to be interpreted in a myriad of ways. In this phase, the project focuses mainly on the structural framework rather than the exhibits (V1) or the doors concealing them (V2).

VF: Layering of meaning

In the 'Twenty-Four Doors to Christmas' exhibition, a variety of themes which the Smithsons had been already working on for a considerable time – 'the stuff and decoration of the urban scene', 'Signs of occupancy', 'lightness of touch', 'the lattice idea', 'the quality of place through the quality of the patterns of use', etc. – converge, overlap and finally materialise.

The space in the gallery, consisting of three connecting rooms, is transformed into a single, continuous, fluid and changing space that expands and contracts, inviting visitors to discover many different situations and points of view. The outcome is a playful space suitable for a wide range of uses described by Alison (when she resumed the project of the exhibition ten years later) in her article 'Into the Air' thus: 'Children dashing about, opening the doors, then finding the route obstructed, would duck and pass through the frames as if making their way through a holly red wooden grove.'¹⁹ Red lattices, held between floor and ceiling by green wedges, hark back to the Lucas Headquarters project designed by the Smithsons years earlier featuring a red structure against the green landscape that acted as a bridging element between city and countryside.

Alison Smithson explained how 'in such a small space as Kettle's Yard the red frame was also a line of trees reborn, meandering into the distance as in a landscape; a line returning on itself, making a place in the red structure, advancing again and promising a safe journey's-end to the small child who enters this seeming forest of red posts'.²⁰

The wooden framework, akin to a traditional Christmas arcade, consisted of a series of identical 50x102mm uprights arranged in more or less constant units (800mm / 500mm) with a specific geometry (0° / 45° / 90°), and yet created an infinite variety of shapes able to house the different showcases whilst creating an all-enveloping and evocative atmosphere: an enabling framework of wooden lattices where 'the themes of the Christmas Festival were given a presence suitable to the children who were to open the Doors'.²¹

19 Alison Smithson, 'Into the Air', *MASS. Journal of the School of Architecture and Planning*, VII (1989), 7–10.

20 Alison Smithson, 'Strati E Stratificazioni / Layers and Layering', *Spazio e Società*, n. 13 (1981), 96–100.

21 Peter Smithson, 'The Lattice Idea', *ILASUD Yearbook 1999*, 58–61.

14 View of the exhibition from the entrance.



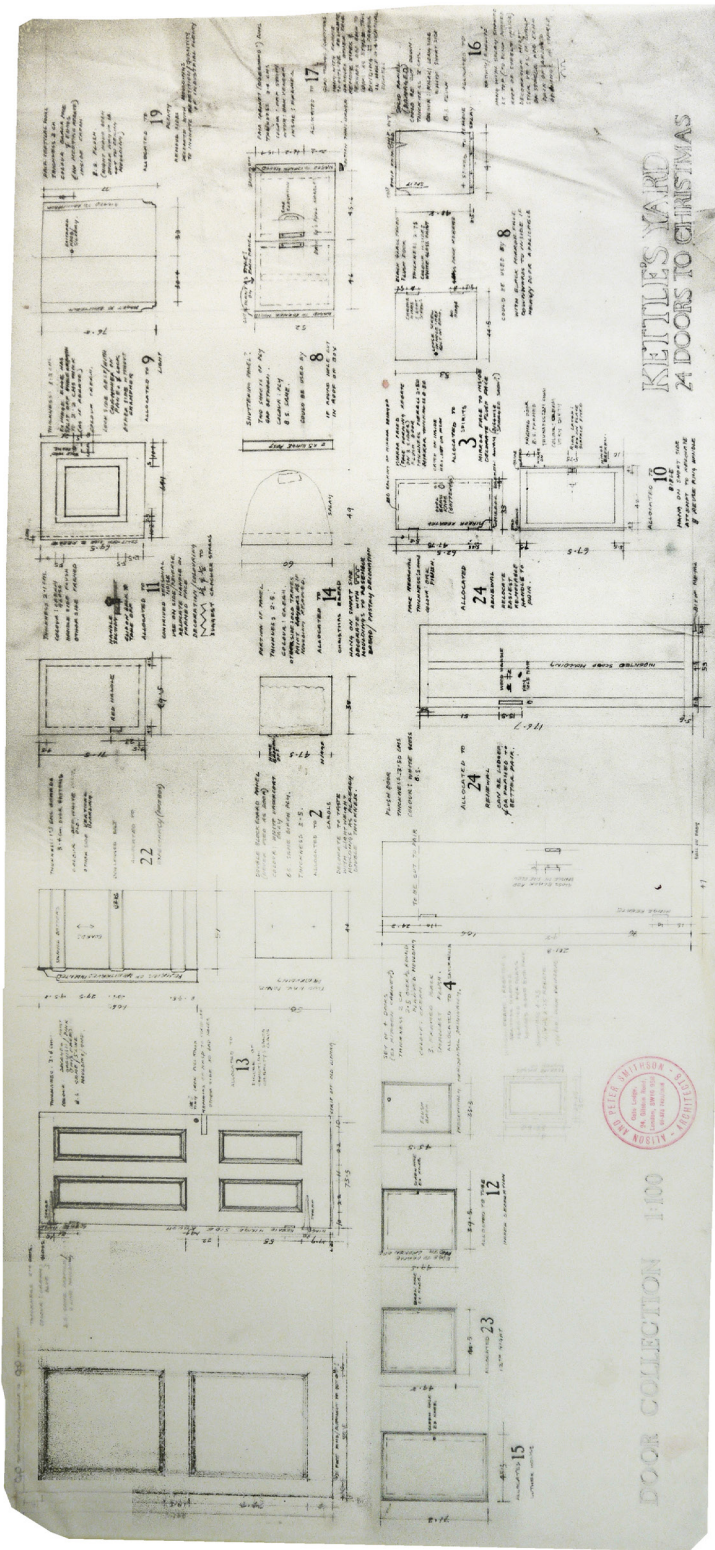

15 Door Collection, 1:100.
AS, 1979.

The circulation route nonetheless had a beginning and an end. No one could get lost in this wood thanks to the path that led the visitors into the wood and then helped them find their way out after visiting the exhibition. The framework created a continuous path highlighted by the correlative numbers of the doors, ensuring that visitors did not miss the story line running through the exhibition – a message complemented by the small exhibition catalogue in which the exhibits are listed using the same numbers.

The intention of all this is not merely nostalgic. It is, as the attractive catalogue makes clear, also instructive. The tableaux behind the doors illustrate not only familiar but also forgotten aspects of Christmas, from its links with the Roman Saturnalia to the origins of its best-known symbolism. [...] But we need not to be too determined to learn from this exhibition. It provides enough to enjoy for its own sake and, like Christmas itself, it is best enjoyed in the company of children.²²

Most of the doors were recycled, 'as found' objects, a metaphor of the ruins of the past, each one integrated into the exhibition with its own characteristics and peculiarities. The other doors were made of the plywood left over from making the boxes. One of the drawings shows how plywood was used to make boxes and doors. As a result, the doors are all different (different materials, size, thickness, etc.), and yet they tone in with the thread of the exhibition as a whole by blending in with its colour code. They were repainted in different combinations of the basic colours – red, green and white – and some were decorated or trimmed to match what lay behind them.

Most of the doors were originally cupboard doors but the ones appearing in the graphics of the catalogue and the poster were house doors. House doors with garlands that convey the spirit of Christmas. The nexus with Peter Smithson's talk 'In Praise of Cupboard doors', appears once again: 'As the cupboard is to the house, so the house is to the town.'

Each of the twenty-four displays consists of a door, a box and exhibits, and is painstakingly designed to illustrate one of the chosen aspects of Christmas in England. There is a set of fourteen plans on a scale of 1:25 with details of each display that will finally appear in the exhibition. Far from being relegated to the background by the design process, these displays were actually the contents of the exhibition, it transformed them making them an essential layer brimming with meaning. Each arrangement of objects and each evocative scene consisted of art works, pop-art objects, antiques or modern, tawdry or valuable, whose mission was to awaken society's sense of its own power, to take responsibility for the look of places. 'In the modest Kettle's Yard exhibition, objects chosen to illustrate something of the history of this Christmas decoration, will be grouped as a spectacle of traditions which should appeal to both children and adults.'²³ In short, this was the real intention of the exhibition. The structure was merely the support or framework enabling the

22 Frank Withford, 'Christmas Remembered...', *Cambridge Evening News* (Cambridge, 1979).

23 Alison Smithson, *An Anthology of Christmas*.

contents to be interpreted properly, the resource making it possible to inhabit the exhibition and establish adequate communication.

The nineteen seventies was for us a decade of exploration of braces becoming lattices... for example those built at St. Hilda's College, or those in the extended studies for the Lucas Headquarters.

Of course in these fixed lattices of the 'seventies we were concerned above all else to give a place to the arts of inhabitation.

[...] In the 'seventies also, we ourselves inhabited a lattice, in an exhibition called Twenty-Four Doors to Christmas.²⁴

24 Peter Smithson, 'The Lattice Idea'.

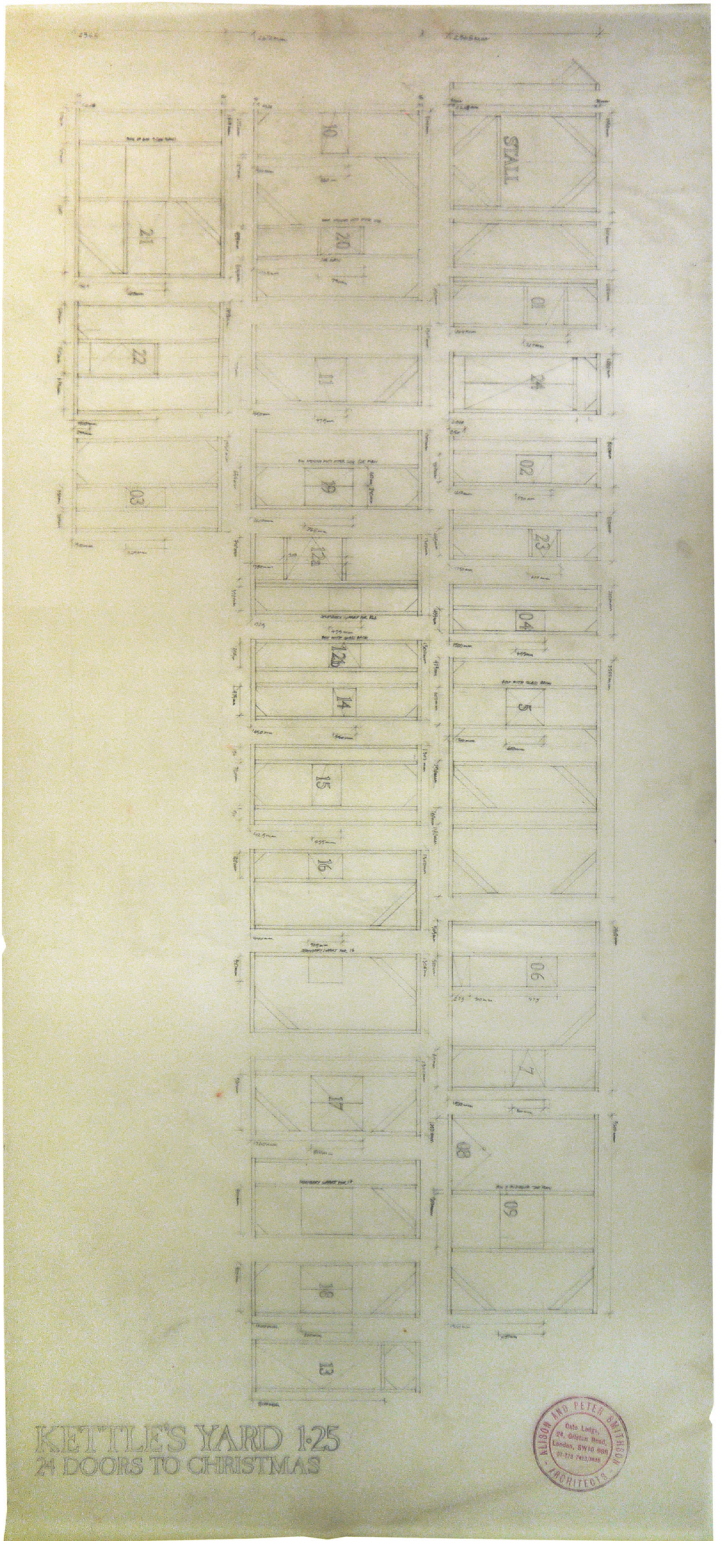

16 Exploded view of framework, 1:100.
AS, 1979.

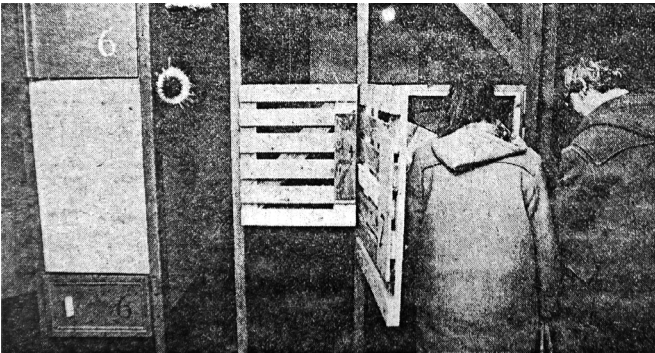

17 Father and child open a door. PS, 1979.

18 Three girls open a door. PS, 1979.

19 Recalling childhood memories at Kettle's Yard.

20 Ground plan of the Kettle's Yard gallery showing final layout with dimensions. AS, 1979.

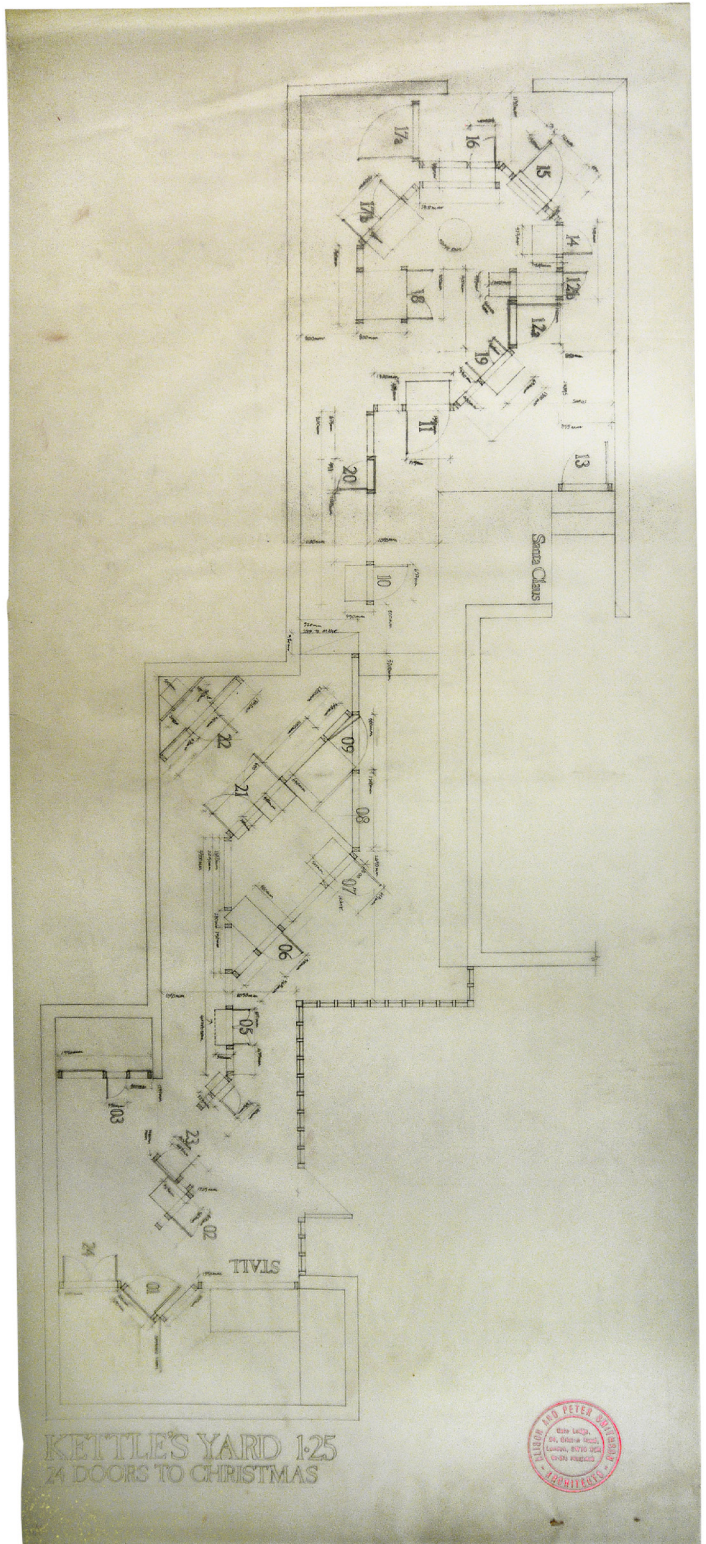

EVERGREEN

12

door

DOOR OF 1/2" PLYWOOD
W: 710
H: 900

HANG ON STRUCTURE

PLANT 1/2" PLY STRIP AS
PULL HANDLE ON
OPENING SIDE: W: 090

COLOUR OF DOOR

1/2 GREEN

1/2 RED
NUMBER 12 IN WHITE
B.S. OF DOOR

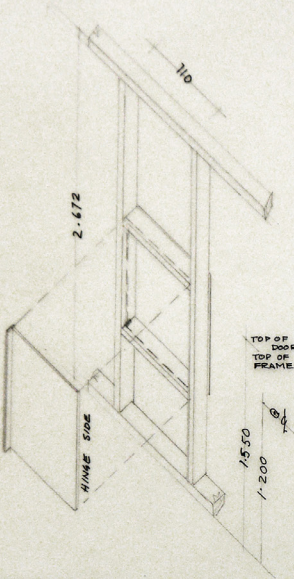

box

BOX FORMED BY STRUCTURAL FRAME

BOX OUTSIDE W: 710 INSIDE W: 609

H: 900 H: 898

DEPTH: 115 D: 102

GLAZED DEPTH: 87

GLAZED IMMEDIATELY PICTURE POSITIONED

CONTENTS WHITWORTH NOLLY GATHERERS W: 600 H: 852 KETTLE'S POSITION

LIGHT FROM OUTSIDE BY WELL DISTANCED SPOT SO AS NOT TO HAVE MORE THAN 50 LUX ON PICTURE

ASSOCIATED WORK: MISGING BUNCH TO BE MADE AND HUNG

EVERGREEN SWAGS - AT LEAST 2
STRETCHING AS FAR AS LEFT & RIGHT
STRUCTURAL FRAME DOOR 13 - TO BE
MADE AND HUNG

1/2" PLYWOOD PANELS CUT FOR DOOR & BACK

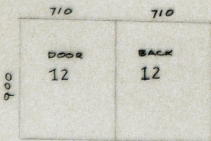

1:25

PAPER DECORATION

12

door

DOOR FROM COLLECTION
BEAD MouldING
(BARKEN OFF) SIDE

W: 395

H: 495

THICKNESS: 020

HANG ON STRUCTURE

PLANT 1/2" PLY STRIP AS
PULL HANDLE ON SIDE WHOSE
BEAD BROKEN OFF: W: 050

COLOUR OF DOOR

1/2 RED

1/2 GREEN

NOTE REVERSE
DAPEN TO OTHER 12

NUMBER 12 IN WHITE ON B.S. OF DOOR

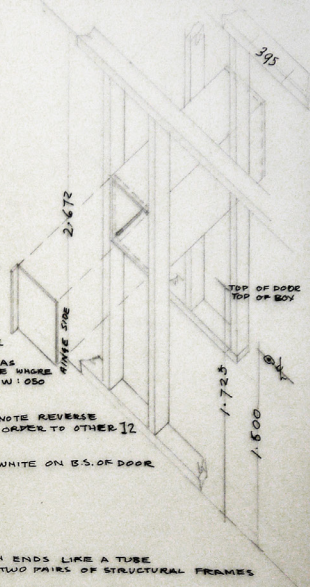

box

"BOX" IS OPEN BOTH ENDS LIKE A TUBE
TUBE SUPPORTED BY TWO PAIRS OF STRUCTURAL FRAMES

TUBE OUTSIDE W: 395 INSIDE W: 370

H: 495 H: 470

DEPTH: 1.213 D: 1.200

NETTED DEPTH: 1.150

CHICKEN NET IMMEDIATELY PAPER CLIPPERS POSITIONED

ENHICHEN NETTED BOTH ENDS TO ALLOW AIR MOVEMENT TO

MOVE PAPER AND ADD BUILD UP OF HEAT

NOTE: BEADS MAY NEED TO BE FULL LENGTH OF TUBE TO

STRENGTHEN

CONTENTS: PAPER DECORATIONS: STREAMERS, CARLANDS,

PAPER CLIPPERS + 1/2 CLIPPED PAPER KETTLE'S POSITION

LIGHT FROM TOP THROUGH HOLES IN TUBE CEILING

1/2" PLYWOOD PANELS CUT FOR TUBE.

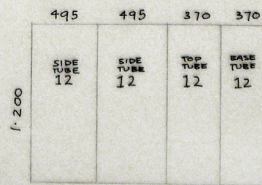

↑
o o o
o o o
o o o
o o o
DRILL
HOLES
MID AREA

1:25

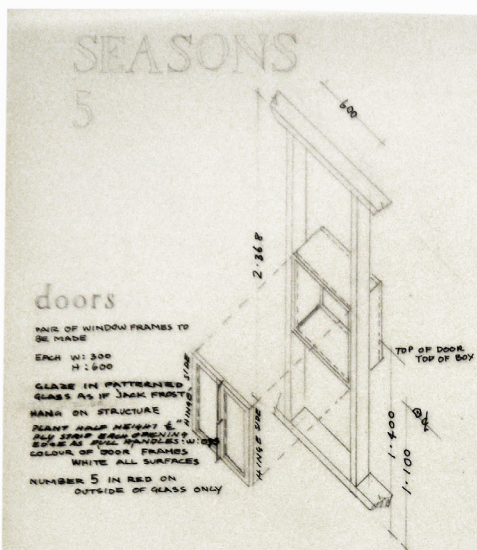

doors

RAIL OF WINDOW FRAMES TO BE MADE
EACH W: 300 H: 600

GLAZE IN PATTERNEED GLASS AS IF JACK FROST
HANG ON STRUCTURE

FASTEN HANG HEIGHT 4" ALL STRIPS BEING OPENING BEHIND AS PER INSTRUCTIONS BELOW OF DOOR FRAMES
WHITE ALL SURFACES

NUMBER 5 IN RED ON OUTSIDE OF GLASS ONLY

box

BOX CANTILEVERED BEHIND STRUCTURE

BOX SIZE OUTSIDE W: 600 INSIDE W: 575
H: 600 H: 575
DEPTH: 300 GLAZED DEPTH: 250

BOTH ENDS OF 'OPEN' BOX TO BE CHECKED NETTED AND SPRAY FROSTED BEFORE OBJECTS INSTALLED

CONTENTS OF BOX: SNOWMAN LUCKY DRAW W/TO H: 440
ROBIN (ON HEAD OF SNOWMAN?)
KUNNIE RUPRECHT DOLLS
SNOWBALLS
ARTIFICIAL SNOW
KNIFE RUPRECHT CAKE FIGURES

LIGHT FROM TOP THROUGH HOLES IN BOX

SPECIAL: CONTINUOUS CORNER FILLETS TO STRENGTHEN SIDES.

ASSOCIATED WORKS MIRROR BALL TO HANG SPOT TO SHINE ON MIRROR BALL

WINDOWS TO YARD TO OBSOURE/FROST ICICLES TO MASK BLACK EFFECT OF POSTS.

FOOTPRINTS IN YARD INTO INVESTIGATORS DESK.

SNOWFLAKE FALLS, WHERE NECESSARY (IE. IN DULL PATCHES, OR MASKING OF WALLS REQUIRED)

1/2" PLYWOOD PANELS CUT FOR BOX

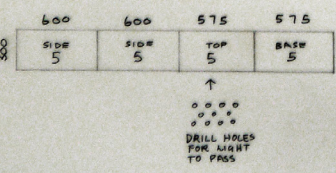

1:25

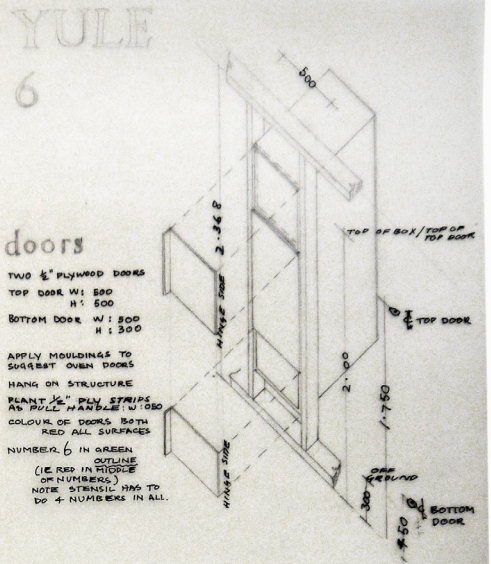

doors

TWO 1/2" PLYWOOD DOORS
TOP DOOR W: 500 H: 500
BOTTOM DOOR W: 500 H: 300

APPLY MOULDINGS TO SUGGEST OVEN DOORS
HANG ON STRUCTURE

PLANT 1/2" PLY STRIPS AS PULL HANDLE W/100
COLOUR OF DOORS BOTH RED ALL SURFACES

NUMBER 6 IN GREEN OUTLINE (IE RED IN MIDDLE OF NUMBERS)
NOTE STENCIL HANG TO DO 4 NUMBERS IN ALL.

box

STABILIZED CANTILEVER BEHIND STRUCTURE

BOX SIZE OUTSIDE W: 500 INSIDE W: 475
H: 1100 H: 1075
DEPTH: 300 GLAZED DEPTH: 275

TOP OPENING TO BE GLAZED; NOTE BOTTOM LEDGE NECESSARY
BOTTOM OPENING NO GLAZING REQUIRED

CONTENTS OF BOX: FIRE FLICKER } BOTTOM YULE LOG
SANTA'S BOOTS (AT REAR) } AT TOP
STOCKINGS (AT FRONT) }
[TRICKS IF DESIRED FOR BOTTOM OF BOX TO REPRESENT ASHES IE RED SILVER]

LIGHT INTERNAL FROM FLICKER OR 'FINE' LIGHT.

SPECIAL: COLOUR INSIDE SURFACES OF BOX - CEILING BLACK & PART DOWN SIDES FLOOR & SIDES & BACK RED WITH BLACK IN CORNERS

SILVER FOIL IN FLAME SHAPES FOR REFLECTING FLICKER TO REDUCATE FROM FIRE. CRANSE GRABBE ADHERING TO SURFACES?

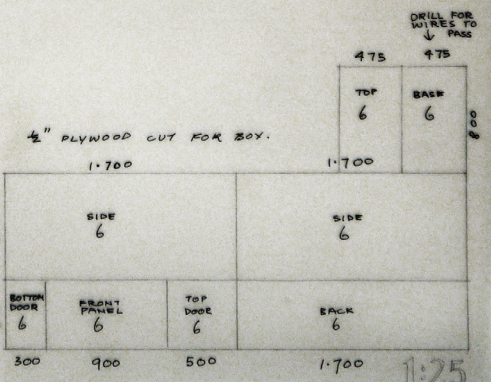

21 and 22 Detailed instruction sheets for each display: boxes, doors and contents, 1:25. Box 5 'Season', Box 6 'Yule', and Box 12 'Decoration'. AS, 1979.



23 General view of kissing ring enclosure made of store doors, with Box 16 'Nativité, Egalité, Fraternité' in the foreground.



24 View of the exhibition with trees along the wall on the right, and Box 7 'Feasting' (open) and Box 8 'Mumming' (closed) on the left. Sam Lambert, 1979.



24 DOORS TO CHRISTMAS



THE 24 DOORS OF THE ADVENT CALENDAR

In the 19th Swedish charitable organizations, as a means of raising funds, introduced the Advent Calendar of 24 little doors bearing the dates in December up to Christmas Eve. The idea was taken up in Catholic Germany where Advent is kept as a church and a domestic festival.

ADVENT

To quote Clement Miller: "The first mention of a season corresponding to Advent is at the Council of Tours, about 567, where a fast for monks in December is vaguely indicated . . . Gregory the Great, adopted the rule of the four Sundays in Advent. Few parts of the Roman liturgy have more beauty than the Advent offices . . . to prepare the minds of the faithful for the coming of the Christ, for the celebration of the Nativity. If we turn to the opening service of the Christmas Year, the First Vespers of the First Sunday in Advent, we shall find in the first words in the "Proper to the Season" the trumpet-note of St. Paul: "Brethren, it is high time to awake out of sleep, for now a salvation nearer than when we began." Advent is a time of longing expectancy. It is a season of waiting patiently for the Lord . . . There are four weeks in Advent . . . The fourth week is now completed. Christmas Eve is regarded as not part of Advent . . . Looking forward to above all things the song of Advent . . . the Church waits, at this darkest time of the year, the rising of the Sun of Righteousness."



3 SPIRITS

The Venerable Bede is said to refer to the leaving of food on the table overnight at Christmas time for the benefit of invisible guests. These unseen Yuletide visitors were an ancient Scandinavian tradition whose traces can be found elsewhere in Europe, intermingled with the Celtic and the Germanic gods. Although Christ's Mass covers twelve days, the power of Yule deities can remain past Epiphany until Candlemas. Cleanliness, the stiling of normal activities, hospitable provisions, alms to the hungry of candlelight, evergreens, conical noisemakers, protect the living and put to rest the spirits.



4 SATURNALIA

According to Miles: "The use of evergreens as decorations can be traced to Roman Saturnalia. The evergreen plant as refuge for woodpeckers was a Roman belief, and the early church found that evergreens with holly in wood sprigs, in a warty form, were held throughout Europe and Scandinavia . . . The strictly religious feast of the SATURNALIA was held on December 17th, but the festival customs were kept up for seven days, thus lasting until the day before our Christmas Eve. Among them was a fair called the SILLIARDUM CELEBRITAS, for the sale of little images of clay or paste which were given away as presents. With this may be compared the fair still held in Rome in the Piazza Navona just before Christmas, at which booths are hung with little clay figures for the use in PRESEPI. One cannot help being reminded here, though probably there is no direct connection, of the biscuits in human shapes to be seen in German markets and shops."

VESICAPISCIS OR CHRISTMAS FISHES

The Vesica Piscis, or the early and medieval Church, representation of the body of Christ and the Christian Church, is remembered in western France in the Christmas tree of fishes.

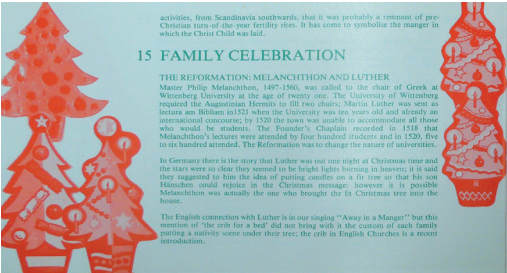

15 FAMILY CELEBRATION

THE REFORMATION: MELANCHTHON AND LUTHER
 Master Philip Melanchthon, 1497-1560, was called to the chair of Greek at Wittenberg University at the age of twenty-one. The University of Wittenberg required the Augustinian Hermits to fill two chairs; Martin Luther was sent as lecturer on Hebrew in 1512 when the university was ten years old and already an international concourse, by 1520 the town was unable to accommodate all those who would be students. The Founder's Chaplain recorded in 1518 that Melanchthon's lectures were attended by four hundred students and in 1520, five to ten hundred attended. The Reformation was to change the nature of universities.

In Germany there is the story that Luther was out one night at Christmas time and the stars were so clear they seemed to be bright figures burning in heaven; it is said they suggested to him the idea of putting candles on a fir tree to fit out Hanschen could replace in the Christmas manger; however, it is possible Melanchthon was actually the one who brought the fir Christmas tree into the house.

The English connects with Luther is in our singing "Away in a Manger" but this version of the crib for a babe did not bring with it the custom of each family putting a nativity scene under their tree; the crib in English Churches is a recent introduction.

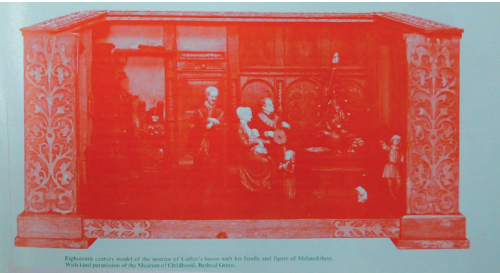

Highwood's century model of the interior of Luther's house with his family and figure of Melanchthon. With copy permission of the Missouri Historical Society, St. Louis.

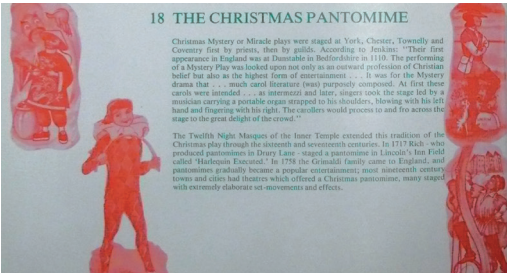

18 THE CHRISTMAS PANTOMIME

Christmas Mystery or Miracle plays were staged at York, Chester, Townly and Coventry first by priests, then by guilds. According to Jenkins: "Their first appearance in England was at Dunstable in Bedfordshire in 1110. The performing of a Mystery Play was looked upon not only as an earnest profession of Christian belief but also as the highest form of entertainment . . . It was for the Mystery drama that . . . much careful literature [was] purposely composed. At first these carols were intended . . . as intermezzi and later, singers took the stage led by a musician carrying a portable organ strapped to his shoulders, blowing with his left hand and fingering with his right. The carolers would proceed to and fro across the stage to the great delight of the crowd."

The Twelfth Night Masques of the Inner Temple extended this tradition of the Christmas plays through the sixteenth and seventeenth centuries. In 1717 Bach who produced pantomimes in Drury Lane - staged a pantomime in Lincoln's Inn Field called "Milkmaids Excused". In 1758 the Gracaldi family came to England, and pantomimes gradually became a popular entertainment; most nineteenth century towns and cities had theatres which offered a Christmas pantomime, many staged with extremely elaborate set-movements and effects.

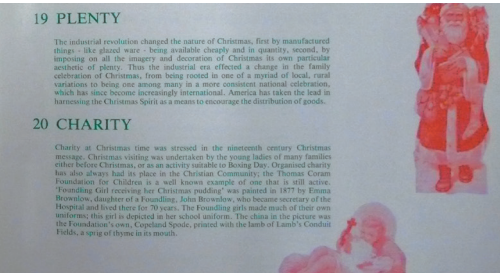

19 PLENTY

The industrial revolution changed the nature of Christmas, first by manufactured things - like alcohol were - being available cheaply and in quantity, second, by imposing on all the imagery and decoration of Christmas its own particular aesthetic of plenty. Thus the industrial era effected a change in the family celebration of Christmas, from being rooted in one of a myriad of local, rural variations to being one among many in a more consistent national celebration, which has since become increasingly international. America has taken the lead in harnessing the Christmas Spirit as a means to encourage the distribution of goods.

20 CHARITY

Charity at Christmas time was stressed in the nineteenth century Christmas message. Christmas visiting was undertaken by the young ladies of many families either before Christmas, or on an activity suitable to Boxing Day. Organized charity has also always had its place in the Christian Community; the Thomas Coram Foundation for Children is a well known example of one that is still active. "Founding Girl" receiving her Christmas pudding" was painted in 1877 by Emma Bowdler, daughter of a Foundling. John Bowdler, who became secretary of the Hospital and lived there for 70 years. The Foundling girls made masks of their own uniforms; this girl is depicted in her school uniform. The child in the picture was the Foundling's own, Christina Spence, graced with the hands of Lady's Convent Girls, and a sprig of thyme in its mouth.

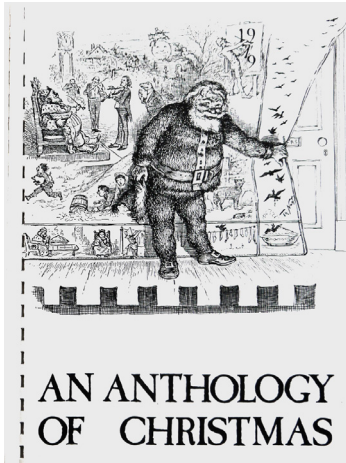

30-33 'An Anthology of Christmas'. Cover and sample pages.

Briefing document for students of architecture at Bath University.

This document is a compilation of a series of quotations from the seventh century to the 1970s about the growth in Britain of celebrations at Christmas and New Year. Once again it addresses the context and origins of Christmas, giving students a historical background and enabling them to understand Christmas as a part of everyday life separate from religion and fashion.

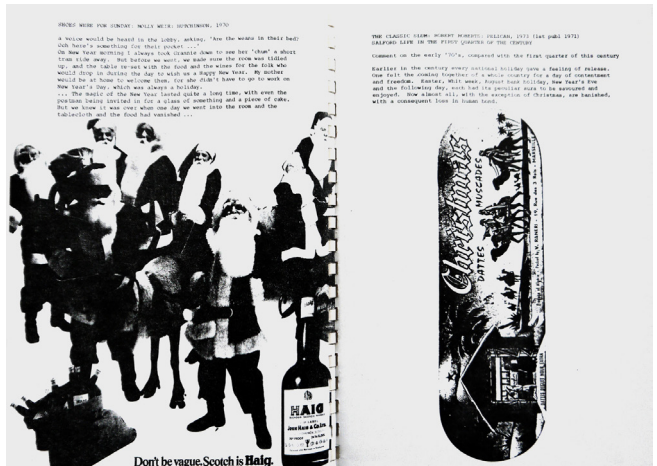
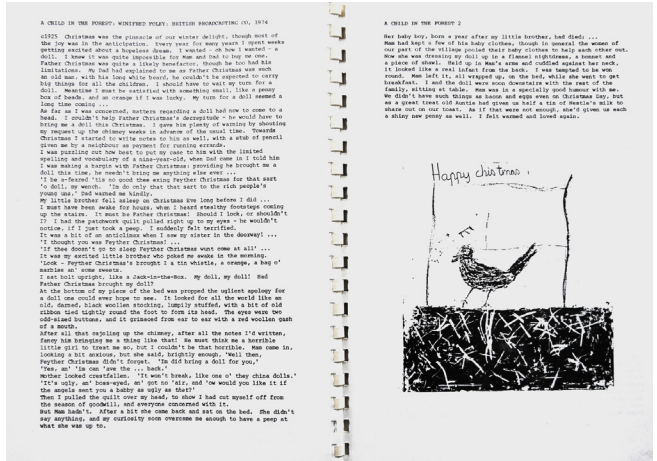
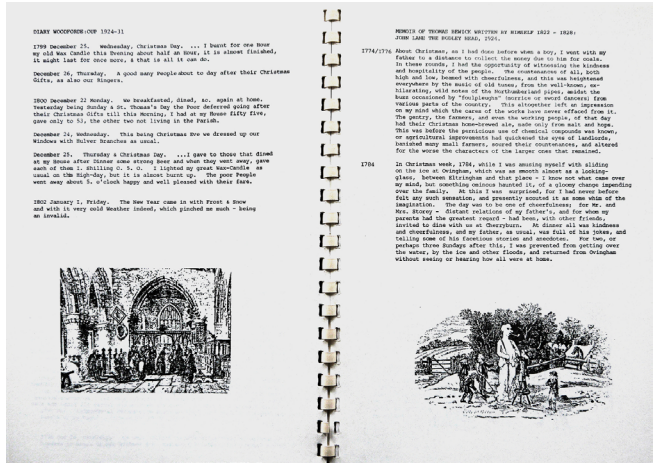

A SCOTTISH ARTS COUNCIL EXHIBITION
FRUIT MARKET GALLERY
MARKET STREET
EDINBURGH



10^{AM} ~ 6^{PM} MONDAY TO SATURDAY
17 DECEMBER TO 17 JANUARY

CLOSED 25 12
26 23
A.M.S.

34 Poster of the Christmas - Hogmanay exhibition.

Christmas & Hogmanay

Alison Smithson

1980-1981

Venue and dates: The Fruit Market Gallery, Edinburgh. 17 December 1980 – 17 January 1981.

Organizers: Scottish Arts Council.

Design: Alison Smithson. Early summer 1980 – January 1981.

Curator: -

Construction team: Students of the Edinburgh College of Art.

Work team: -

Gross floor area: 300 sq.m.

Itinerary: None.

Exhibition catalogue:

'Christmas-Hogmanay Exhibition' Alison Smithson ed., 1980 (envelope containing leaflets about these traditions in Scotland).

Related publication: -

Additional information:

Reviews:

The Sunday Times, 28 December 1980.

The Christmas-Hogmanay exhibition addresses once again the theme of collective decoration in this festive period, although in this instance the analysis focuses on the traditions typical of Scotland. Here too, the title of the exhibition suggests what the exhibition seeks to convey: *Christmas* followed by the word *Hogmanay*, with a Christogram between them.

Hogmanay in Gaelic (is) a *Chaaluinn* or *Odiliche bam Bennag*, New Year's Eve.

Brewer derives the word from the Saxon *halig monath* or holy month, and states that King Haco of Norway fixed the feast of Yule on Christmas Day, the eve of which was called Hogg-night, but the Scots were taught by the French to transfer the feast of Yule to the feast of Noel, and Hogg-night has ever since been the eve of New Year's Day.²⁵

Norway, England, Ireland, France, ... Different, interwoven traditions that shaped the Scottish celebration, were originally encompassed by Yule time and subsequently transformed by Christianity. In short, a time of celebration, a turn-of-the-year festival, marked by two great moments: Christmas and Hogmanay. The two facets of the celebrations, one religious and one pagan, joined by a Christogram – a good omen since Roman times.

The use of the Chi-Rho Christogram – a symbol formed by superimposing the Greek letters X (chi) and R (rho) – in the title of the exhibition is particularly eloquent. The Chi-Rho is said to be of pagan origin for it was used to mark prophetic passages in pagan papyri: X and R are the first two letters of the Greek word *xrestós* meaning benevolent. But after Constantine I, the first Roman emperor to convert to Christianity, used it on his standard when waging the Battle of the Milvian Bridge (312), iconographic tradition began to associate the Chi-Rho with victory – and also with Christianity. X and R are also the first two letters of *Xristós*, Greek for Christ, and when the Chi-Rho appeared on Roman coins following the Edict of Milan in 313 that allowed Christianity to be practised in the Roman Empire, this symbol became part of Christian iconography once and for all.²⁶ This is a very good example of how ancient traditions are renewed and incorporated into Christianity, as when Christmas began to be celebrated as Yule or Hogmanay in this instance.

The story line of the exhibition starts, at the entrance of the hall, like the exhibition catalogue: with crosses. Celtic crosses hang from the ceiling and on display is a map of Scottish stone circles and a cross overlay – this is the beginning. 'Crosses announce the fresh beginning that is Christianity. [...] The story of Christmas – the time of year at which Christianity sets its own beginnings – began a change in the nature of

25 In 'Christmas-Hogmanay Exhibition' (Edinburgh: Scottish Arts Council, 1980), Alison Smithson mentions another feast that is also part of the Scottish tradition: *Yule*.

Nordic *bræok*: wheel: turning of season [...]

In Norwegian *jul* ... dates back to pre-Christian times. *Joulu* or *jol* is a pagan feast celebrated all over Northern Europe: late fall or early winter; origin debated: connection with the God Odin [...]

Originally marked winter solstice: occasion when flocks that could not winter were finally slaughtered and feasting commenced to last through darkest days of the year (A Smithson, *Calendar of Christmas*).

26 Many authors address this theme. The author refers in particular to the article by Francisco de Asís García García, 'El Crismón', *Revista Digital de Iconografía Medieval*, II (2010), 21–31.

the Turn-of-the-Year Festival marking the Winter Solstice.²⁷ The message encrypted in the title and the specificity of the place with its particular atmosphere, are clearly revealed at first sight upon entering the hall. A series of overlapping, apparently disorderly layered lattices immediately characterise the general atmosphere of the exhibition.

Shimmering silver lattices evoke the magic of expectancy...the decoration of nature by frost...northern rain in moonlight...Scotch mist.

White lattices evoke the countryside clothed in a garb of snow. Black lattice, night, the turn of the year which heralds the great renewal of life.²⁸

White represents the snow, the weather; silver, the frost or mist, a myth linked to nature; black recalls the longest nights of the year, mystery; and finally red, the colour of expectancy. The colours of the installation match the peculiarities of the reality being presented. The main colours used in the previous two exhibitions – the green, red and white universally associated with Christmas – are disregarded. The aim in this instance is to recall the sensation of experiencing Christmas in Scotland, not only in the household sphere but also by understanding the important role of nature and country life in this particular context. The starting point is, therefore, to present this atmosphere: the primer display is dedicated to Scotland and features fauna and flora, bog myrtle, juniper, heather and stuffed reindeer, birds, hare, etc., and the second, to the byre (cow-shed), with straw, sphagnum moss, juniper, pitcher, stuffed horned cattle, etc.

At first, it seems that everything in the installation overlaps and that the exhibition does not have a clear storyline, unlike '24 Doors', but a closer look reveals that here too everything is presented chronologically as in a calendar:

Yule bread or the turn of the season – December, 22nd

Christmas – December, 25th

Seasonal activities, Santa, Children at Christmas, Guisers,²⁹ Charity

Greetings – Twelve Days of Christmas: Christmas Day to Twelfth Night

Hogmanay – December 31st

Handsel Monday – first Monday of New Year (January 2nd is presumably the first day this could be)

Twelfth Night, Auld Christmas – January 6th

Daft Days – end of the Twelve Days, beginning January 7th

Taste of the East – the flight into Egypt after Auld Christmas

Auld Hogmanay – January 11th

Plough Monday – first Monday after Twelfth Day

Candlemas – February 2nd

27 Alison Smithson, 'Christmas-Hogmanay Exhibition'.

28 Alison Smithson and Peter Smithson, *The Charged Void: Architecture* (New York: Monacelli Press, 2001), p.471.

29 Guiser (syn. mummer), one who wears mask or costume while merrymaking, especially at Christmas and other festive seasons.

Christmas Hogmanay Exhibition

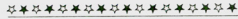

The text of Christmas/Hogmanay contains many Scottish 'voices' that are—through selected quotations—gathered into occasion—groups, in a loose chronological order, tracing the evolution of attitudes to the holding of the festival.

The plotted nature of the tradition makes itself clear in the repetition of events transposed in date, in the seemingly inescapable scatter of location of like celebration. We can read in this, relationships sometimes overlooked in Scottish history, of repeated need for employment or study abroad; of connections across the North Sea when it was the hub of communications around and beyond.

This is not a work of scholarship, no original research has been undertaken; it was compiled as a programme for creating the exhibition and printed as an encouraging brief to those students who would help to make and furnish the spaces. It is hoped that the document will prove an interesting companion to those looking at the exhibition.

Alison Smithson
Summer 1980



To the Visitor to the Exhibition
Fruit Market Gallery,
Edinburgh

TURN OF THE YEAR

1120 1205
1284
1342
1382
1467

1120 1205
The first known of Andrew's possible coronation process for King David I in 1120, in 1205 the same authority at Dunblane assumed such for the coronation of King John.

1284
Pope Nicholas IV, 1284, the Roman issued an act against idolatry and superstition, especially against the Feast of Christmas.

1342
George Prothonaire, Bishop of Glasgow, 1342 Christmas Day, for persons charged with "Christmas the superstitious day called Yule".

1382
"Eight or nine women are known forbidden to have or receive their [the] Christmas Eve and Christmas morn[ing] under the penalty of public correction at the hour during this year which is superstitious to the eve of Christmas in the name of Jesus our Redeemer." — *Historia ecclesie et civitatis Glasgouensis*, the first to be cited in the *Calendar of Scottish Documents*, 1382.

1467
"The Council Assembly in 1467 prohibited all kind measures from granting a holiday on Christmas." — *ibid.*

1469
The Scotch Church pronounced... As they could not hold Christmas without observing the Yule practices with it, they resolved on abolishing both."

1600
The revival of catholic customs at Christmas within the Union is referred to in John Dalrymple's *Memories*, 1600.

1600
"The custom of calling the Yule season... When antique man-hold Christmas morn[ing], For when we were child of Yule, When Christmas came our year."

1600
In just the year that created me When morn[ing] that year was the day, When we were child of Yule, When Christmas came our year."

1600
Report of Town Council of Edinburgh, Christmas Day 1600, students of colleges, indulged in street-rod style and ended up burning an effigy.

1609
On December 2nd James VII was allowed to "visit" the town of Glasgow in France, the town being occupied by Edinburgh, the Chapel Royal at Glasgow was demolished and, according to the *Calendar of Scottish Documents*, Edinburgh's anti-catholic, James burnt an effigy of the Pope at the Market Cross.

1844, 1846, 20th century
However, the process of change in the language of Christmas and Hogmanay was advanced by the success of English Victorian

hospitality at christmas

"In the Gaelic-speaking districts of the northern Highlands, the term *Seòlaid* (i.e. *Whisk Noddy* and *Linn Noddy*) was applied to the whole series of local Christmas Eve and the New Year. During that time, traditions forbade any serious work. The house was decked with holly 'to keep away the faeries', who certainly were not regarded as welcome guests.

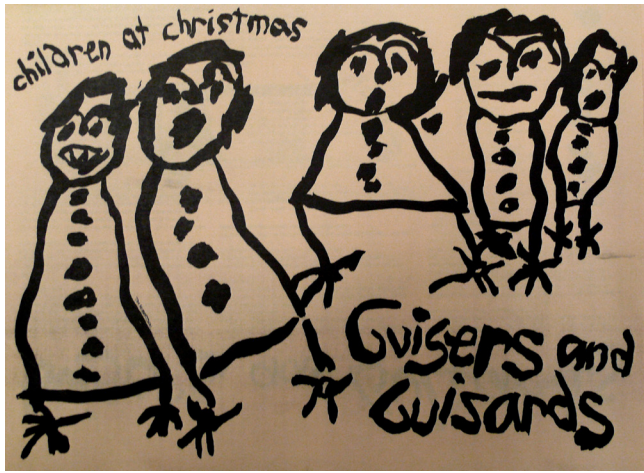

35-43 Catalogue of the Christmas - Hogmanay exhibition. Envelope addressed 'To the Visitor of the Exhibition' and some of the pamphlets inside it featuring texts and quotations about the content of the exhibition.

It is possible to recognise this pattern by taking a look at the *Calendar of Christmas*, the briefing document that Alison drafted in 1976 for the 'Signs of Occupancy' seminar at Bartlett School: an analysis of the different ways Christmas and its associated festivities are celebrated around the globe. For the 'Christmas-Hogmanay' exhibition, however, only items related to Christmas in Scotland were borrowed from that earlier seminar and focussed on. The exhibition catalogue compiles these items and sets them out in a way similar to the exhibition itself: guiding visitors and yet giving them enough freedom to interpret the displays in infinite ways.

The envelope addressed 'To the Visitor of the Exhibition' contains a collection of leaflets (in a variety of sizes, colours, fonts, graphics, etc.) that feature and explain the items found in the original compilation of 1976.

Hence the catalogue is a collection of fragments compiled 'as a programme for creating the exhibition', 'as an encouraging brief to those students who would help to make and furnish the spaces' and as 'an interesting companion to those looking at the exhibition'.³⁰

Like the exhibition's title, content and story line, its spatial and physical organisation is very elaborate. Between July and September of 1980 Alison drew up the documentation needed to define the exhibition at Edinburgh's Fruit Market Gallery: a set of ten plans covering the exhibition project ranging from a general view of the hall with axonometrics and floor plans on a scale of 1:50 down to plans in the tiniest detail on a scale of 1:2.

The modules that characterise the exhibition landscape on all scales are latticed cages made entirely of timberwork painted white, silver, black or red depending on their meaning in the exhibition. They are all 3048mm high (headroom of the hall to the lower edge of the beam) but differ in size and geometry. Once again, only 0°, 45° and 90° angles were used together with three basic modules (750 mm, 1000 mm and 1524 mm). The other dimensions were combinations of the previous ones: 3048 = 1524 + 1524; 2500 = 750 + 1000 + 750; 2000 = 1000 + 1000.

The perimeter framework and diagonal braces were made of 51 x 51 mm battens to which latticed screens made of 25 x 6 mm strips 150 mm apart were attached at a 45° angle. The strips all lay in the same direction to 'evoke the seasonal layers of rain, snow, Scotch mist, among which the exhibits could be found'.³¹ The direction of the lattice in each panel is analysed in each detailed plan to highlight or avoid overlapping the lattices in order to increase or restrict the depth of the visual field and so endow the space of the gallery with a myriad of variety.

This medium was also used to identify two different moments occurring whilst the exhibition was open: Christmas and Hogmanay. Some of the latticed cages featured moveable panels built like just another latticed screen but clearly differentiated from the adjoining box by having a different colour and slats in a

30 Alison Smithson, 'Christmas-Hogmanay Exhibition'.

31 Alison Smithson, *A History of Layers and Layering*, 1980. (Typescript), Harvard Design School, Frances Loeb Library, Special Collections Department, The Alison and Peter Smithson Archive.

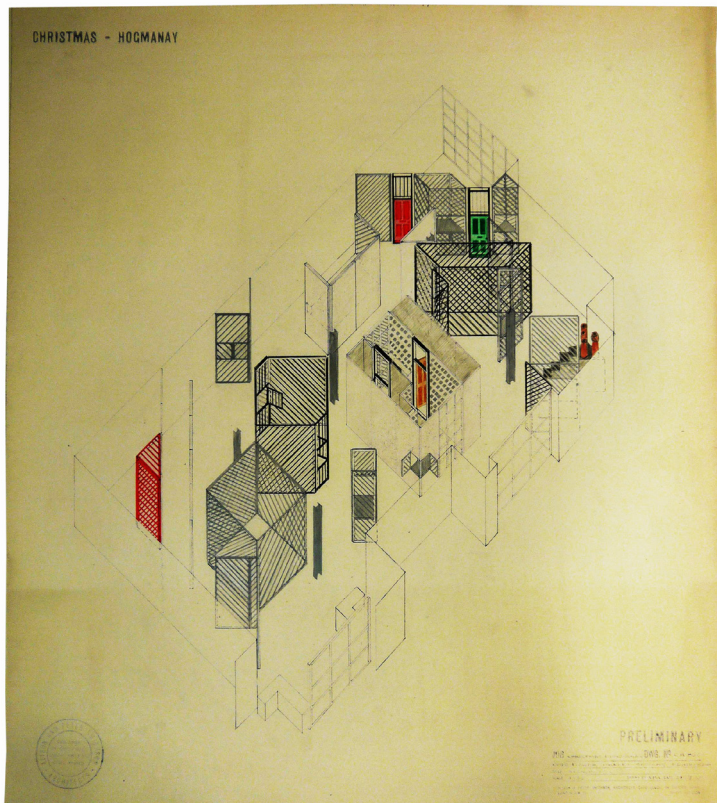

44 CH 8000. Axonometric, 1:50.
AS, July 1980 (Colour version. Chromatic study of the exhibition)
30. CH 8002. Plan with exhibits, 1:50. AMS (25/07/80).

CHRISTMAS - HOGMANAY

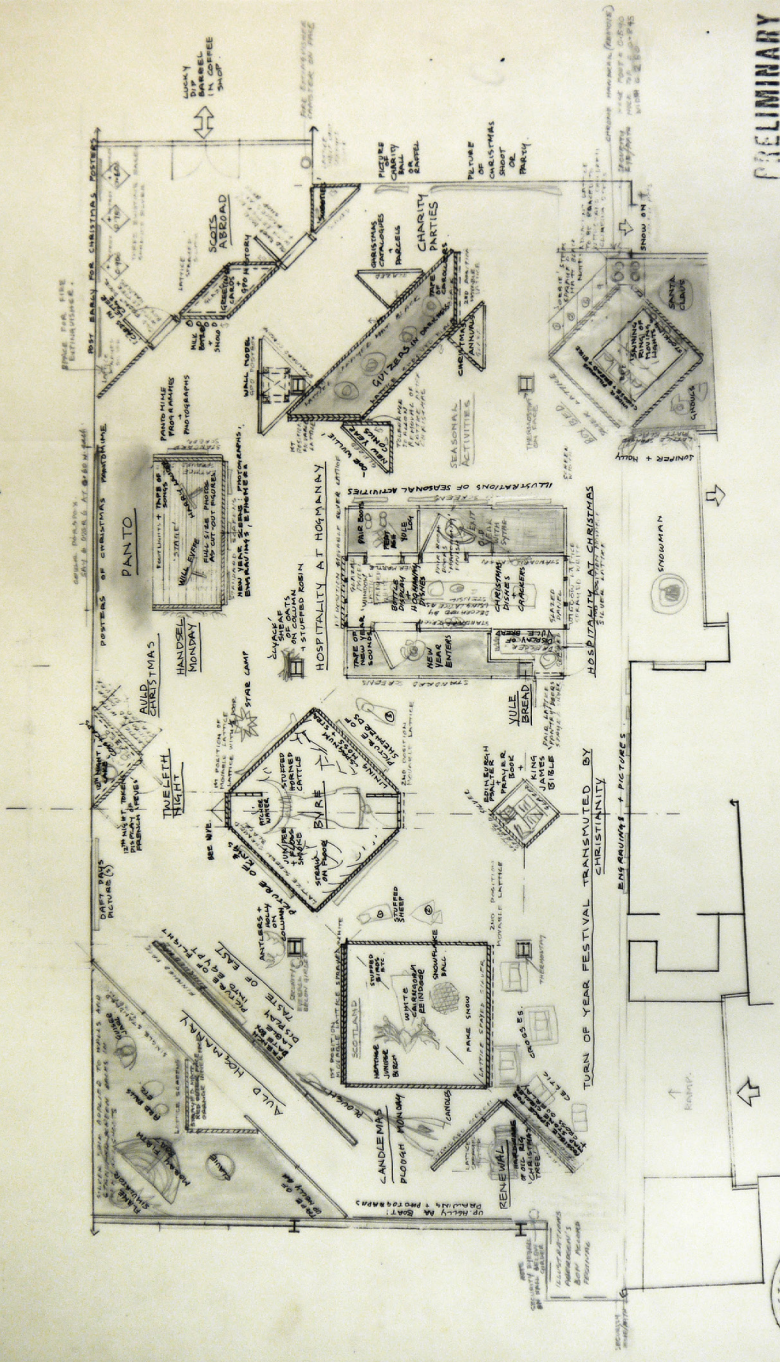

PRELIMINARY

JOB: CHRISTMAS & HOGMANAY DWG. NO. 11 577-2
 AUTHOR: EARL B. HARRIS, B.A. HALLWAY
 TITLE: PLAN OF THE HALLWAY
 SCALE: 1" = 10' DATE: JULY 25, 1960
 ARCHITECT: ALISON & PETER SMITHSON, ARCHITECTS, 45 GUSTON ROAD, LONDON N.W.10



45 CH 8002. Plan with exhibits, 1:50. AMS (25/07/80).

different direction. The location of these moveable panels is not a matter of chance, they are designed to be in just two positions: the first position highlights the aspects related to Christmas, and the second, those related to Hogmanay. In Scotland, Christmas and Hogmanay are of virtually equal importance: both celebrations are preceded by several days of preparation and both celebrations last for twelve days until the day of Auld Christmas and Auld Hogmanay respectively.³² The exhibition installation reflects this duality.³³

All the displays are built of latticed screens with countless possibilities except the Hospitality display with an opaque outside and an interior that is shown to visitors through doors, possibly to confine the space devoted to domesticity and make it private. The doors and the sense of expectancy they create is a device tried out in the previous exhibition and used again here more specifically as part of a latticed atmosphere. The shell of the Pantomime display is opaque too but possibly just for a functional reason, i.e. to create a suitable atmosphere to show a stage inside.

Generally speaking, thanks to the places made specially to house the exhibits and its particular lightness of touch, 'the exhibition creates an environment of expectancy, of discovery, of season, of layers of experience, of surprise'.³⁴ Visitors can look almost right through the exhibition from a myriad of viewpoints that overlap and vary along the circulation route, enjoying for the first time the experience of inhabiting and moving through an architectural framework of lattices. A framework because its mission was, in fact, to configure an enabling frame and an appropriate background in which the exhibits, the diverse items that constitute the contents of the exhibition and which are now not hidden behind a door, can be adequately displayed.

The outcome is an all-enveloping atmosphere shaped by the simultaneous, shifting superimposition of all its inherent layers: the walls of the hall itself, the columns and beams, and Market Street visible through the windows; the white, black, silver, and red lattices; the objects, the scenes, the mannequin, the doors, ... and above all, the exhibition visitors, who are yet another layer of the exhibition and the main part of the installation.

In the layering of spaces - for the eye penetrates the lattices - we build another sort of place - a receptive place which the visitors are invited to decorate by being there: responsibility is returned to them for quality of use, for style of occupancy. Families become part of the exhibition's celebration.³⁵

The last display in the exhibition is a curious 'Christmas Tree'. Displayed behind a silver-on-white lattice is a wellhead on a spreader plate symbolising renewal. This curious 'tree' was inspired by an advertisement that the oil company Mobil published

32 'As we have found at Christmas, Hogmanay was preceded by a flurry of activity which was a mixture between spring cleaning and preparations for a wedding.' A Smithson, 'Christmas-Hogmanay Exhibition'.

33 It was closed from 1 January to 3 January, a good time to move the panels because it coincided with Hogmanay and was half way through the period the exhibition was open to the public.

34 Exhibition flyer. The Alison and Peter Smithson Archive, Harvard.

35 Alison Smithson and Smithson, *The Charged Void: Architecture*. p. 471.

in The Sunday Telegraph on 24 December 1978, and was attached to *The Christmas Tree*,³⁶ a document edited by Alison Smithson as an addendum. The advertisement is styled like an article and entitled 'How to grow more Christmas trees'.

We don't have in mind the traditional festive symbols popularised by Prince Albert, but the tree-shaped capping devices – oil men call them 'Christmas trees' – that sit astride completed wells.

So far we've planted 15 Christmas trees on the deck of our Beryl A production platform in the North Sea. We've placed three others on the seabed, one of them to produce oil five miles away from the platform – the most distant yet attempted in the North Sea.

Through technology, huge infusions of capital and the careful development of people, we're taking risks to ensure that there'll be 'presents' beneath our Christmas trees: the oil the nation expects.

The advertisement article then gives figures and technical details but at this point it has already adequately conveyed the parallels with the traditional Christmas tree and how this expected new source of income, i.e. oil drilling in the North Sea, is a new start for Scotland at that historic moment. Alison repeats this analogy and emphasises the real aim of the installation in one of the catalogue leaflets entitled 'Renewal':

The 'Christmas Tree', alias a well-head assembly of a North Sea oil rig, symbolises renewal. The exhibition CHRISTMAS-HOGMANAY celebrates Renewal. Hopefully the exhibition will inspire an extension of the pattern of change in Scottish celebratory customs. The intention will be fulfilled if the many separate family celebrations together renew communal confidence in the stylish use of places outside the home; by which means cities and the environment come to be creatively renewed.

36 Alison Smithson, *The Christmas Tree*. This document was presented at the 'Signs of Occupancy' seminar held at the Bartlett School in the run-up to Christmas 1976, whereas the advert dates from 1978, therefore the version used by this author is a new edition published after that date.

Renewal

The 'Christmas Tree', alias well-head assembly of a North Sea oil rig, symbolises renewal. The exhibition CHRISTMAS—HOGMANAY celebrates Renewal. Hopefully the exhibition will inspire an extension of the pattern of change in Scottish celebratory customs. The intention will be fulfilled if the many separate family celebrations together renew communal confidence in the stylish use of places outside the home; by which means cities and the environment come to be creatively renewed.

THE SUNDAY TELEGRAPH DECEMBER 24, 1978 PAGE 7

How to grow more Christmas trees.

We don't have in mind the traditional festive symbols popularised by Prince Albert, but the tree-shaped capping devices — oil men call them 'Christmas trees' — that alt astride complex wells.

So far we've planted 15 Christmas trees on the deck of our Beryl A production platform in the North Sea. We've placed three others on the seabed, one of them to produce oil five miles away from the platform — the most distant yet attempted in the North Sea.

Through technology, huge infusions of capital and the careful development of people, we're taking risks to ensure that there'll be 'presents' beneath our Christmas trees: the oil the nation expects. In 1977, the Beryl field's first full year of operation, production amounted to 22 million barrels. The important thing — and a potential problem of North Sea oil — is to resist the temptation to jettison the formula which has led to success. Some countries have made that mistake, once oil is discovered. Happy with the early bounty, they choke off the process under which more oil might be found and developed.

The taxpayer has rightful expectations. But so has the provider of capital, technology and jobs. The many banks, insurance companies and pension funds which have taken a stake in the North Sea have invested the money of their customers, and they too must see a proper return. So must our individual shareholders.

The biggest and most profitable North Sea fields have almost certainly now been found. The next phase of exploration will take us to less promising areas, often in deeper waters. This will be more costly and will require highly sophisticated new technology.

We believe we can provide this technology. And we are confident that the growing expertise of our workforce will be up to the job.

But oil investment is like the pine seedling. It must be nurtured by a suitable environment. Given a healthy investment and operating climate, we will continue to take risks, deploy our skills and supply the needed capital.

So there can be more Christmas trees.

Mobil

Shell is a service mark of the oil companies of North Sea Oil. Shell is a registered trademark of the oil companies of North Sea Oil. Shell is a registered trademark of the oil companies of North Sea Oil. Shell is a registered trademark of the oil companies of North Sea Oil.

46 Leaflet in the Christmas – Hogmanay exhibition catalogue in which Alison mentions the Christmas trees in the North Sea as a symbol of renewal.

47 The Christmas Tree. AS, 1976. Sunday Telegraph cutting attached to the document. An advertisement for the oil company Mobil entitled 'How to grow more Christmas Trees'.



48 CH 8000 axonometric, 1:50. AS (24:7:80).

49 CH 8001 plan with setting out + screen sizes, 1:50. AS (25:7:80).

50 CH 8009 plan: setting out + dimensions, 1:50. AS (28:8:80).

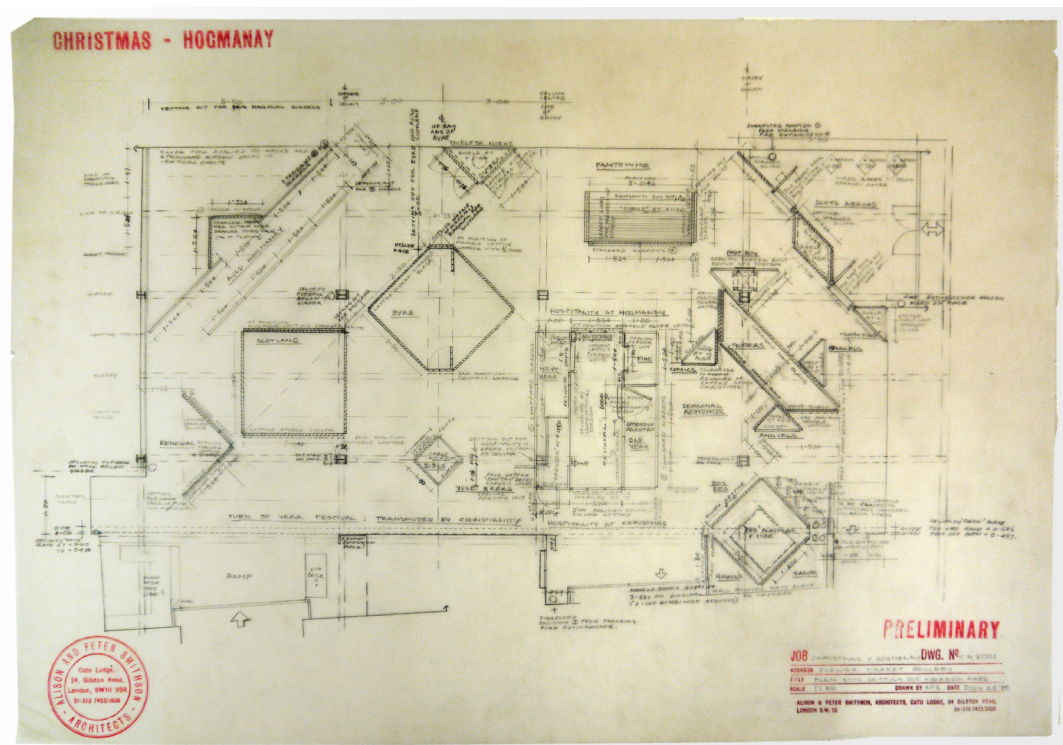

51 Nature of Scotland looking towards
Candlemas.



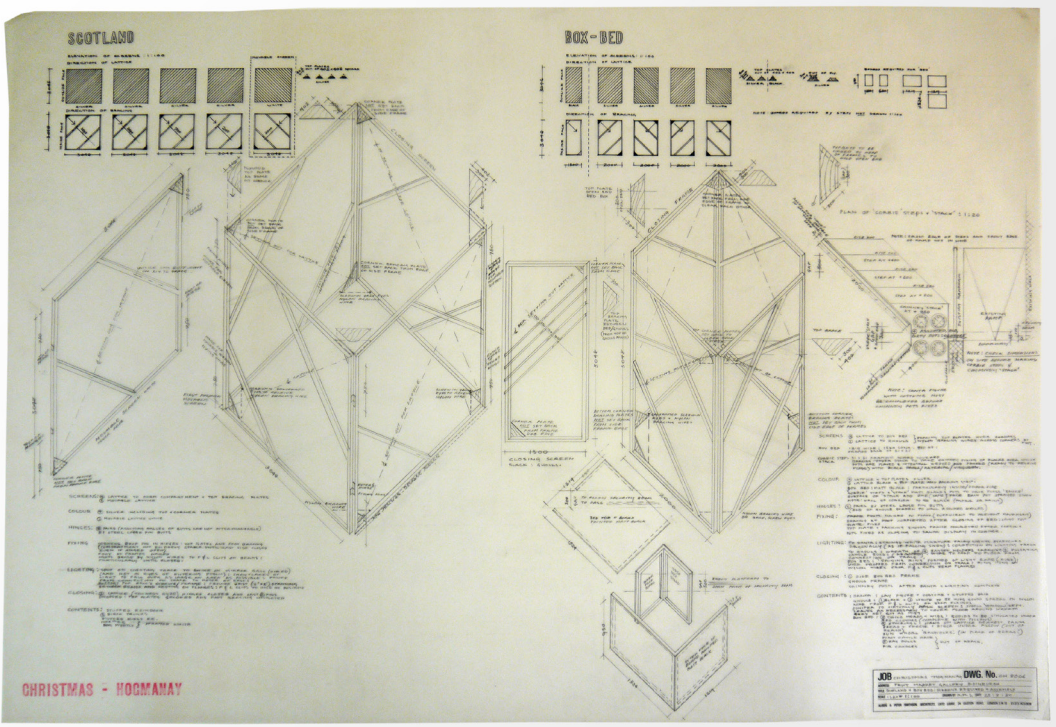
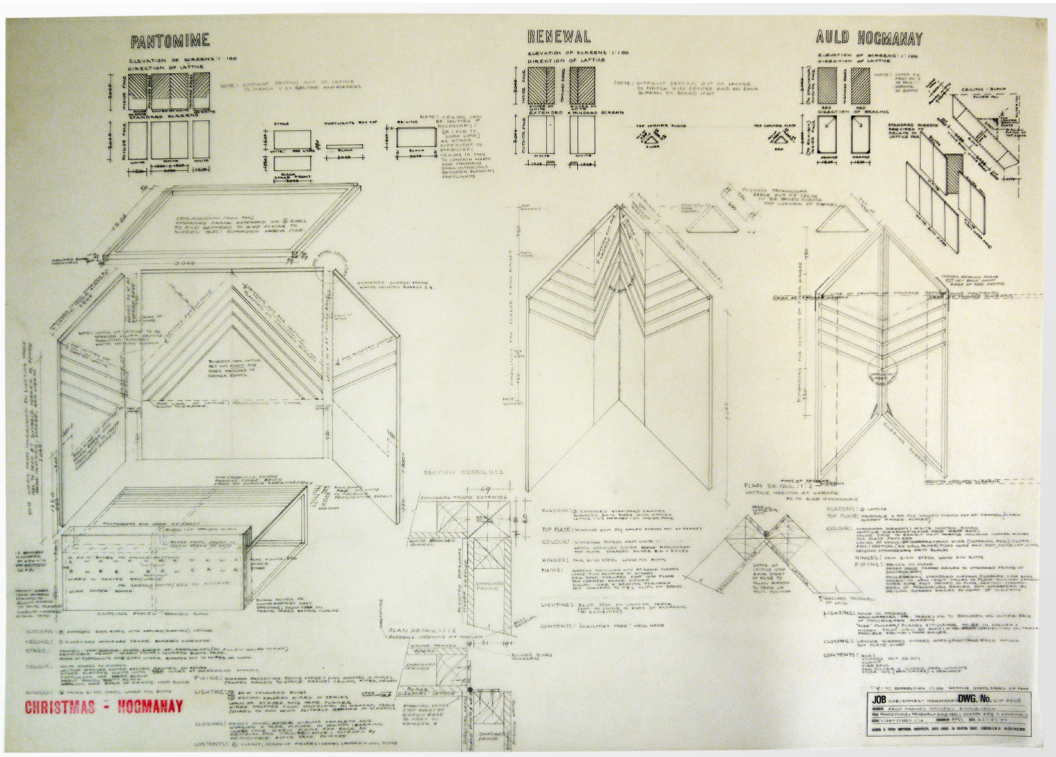

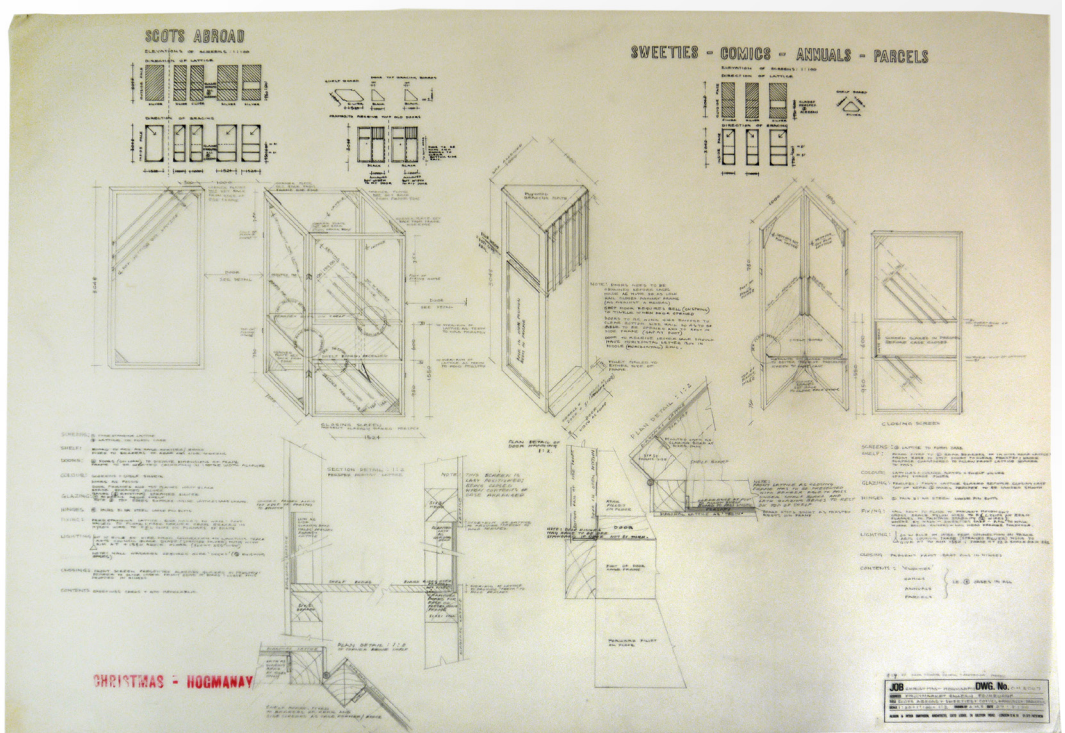

56 CH 8005 Pantomime + Renewal + Auld Hogmanay:
screens required + assembly, 1:100+1:20. AS, (22:8:80).
Corrections and additions 9:9:80.

57 CH 8006 Scotland + box bed: screens required + as-
sembly, 1:100+1:20. AS, (25:8:80).

58 CH 8007 Scots abroad + sweets + comics + annuals +
parcels: screens required + assembly, 1:100+1:20+1:2. AS,
(27:8:80). Corrections and additions 9:9:80.

partition
10 sided figure

P 258

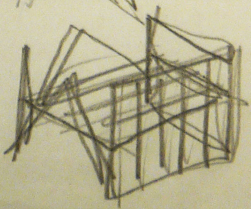
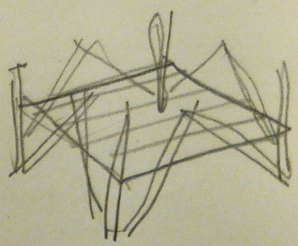
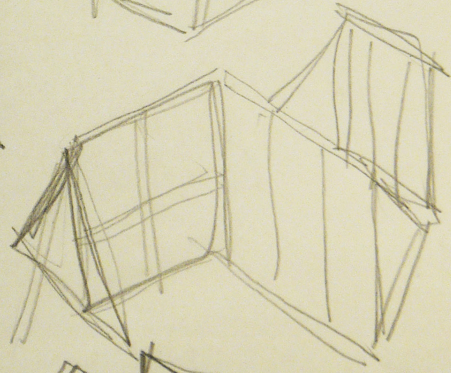
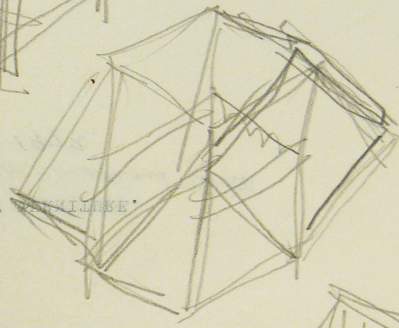
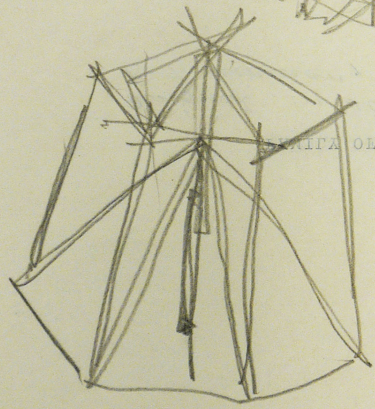
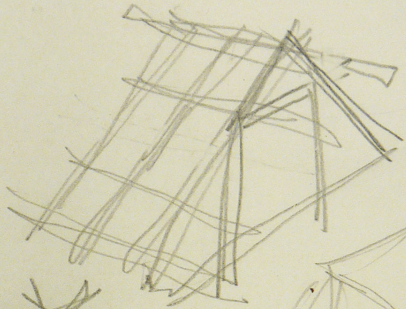
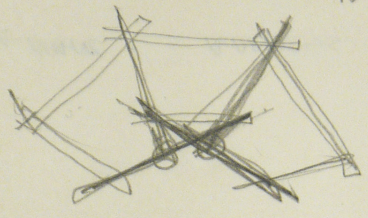

COME DECK THE HALL

AS. 1981

59 'Come Deck the Hall'. Diagram of framework for visitors to hang decorations on. AS.

Come Deck the Hall

Alison Smithson

1981

Venue and dates: 35 King Street Gallery, Bristol. December 1 (or 1st Sunday of Advent) - 31 December 1981 (Planned but finally did not take place).

Organizers: -

Design: Alison Smithson. 1981.

Curator: -

Construction team: Intended to be University of Bath students.

Gross floor area: -

Itinerary: None.

Exhibition catalogue: None.

Related publication: None.

Additional information: Exhibition not held.

Reviews: -

COME DECK THE HALL:

Public participation in the decoration of a Christmas place.

As part of a continuing exercise intended to renew the sense of collective responsibility for the look of places, three event exhibitions of the tradition of people's decoration of their environment at Christmas time have so far been held:

Signs of Occupancy: Bartlett School, London: Banister Fletcher Professorship, 1976-77

24 Doors to Christmas: Cambridge, 1979-80

Christmas Hogmanay: Edinburgh 1980-81

What we think should happen next is an event of public participation, where the visitors are invited to bring 'ephemera' – old, bought, newly fabricated – and either position or hang them in a structural framework which will have been provided as 'another sort of place'. Gradually the exhibition becomes increasingly decorated; so that by Christmas Eve, this special place 'is ready'; made so by the host community.³⁷

So begins a document by Alison Smithson dated April 1981 which introduces another exhibition project to continue with the Christmas theme, and tries to find a venue for the exhibition and a backing organisation.³⁸ The title 'Come Deck the Hall', sounding almost like an advertising slogan, invites people to take part and once again sums up the idea of the exhibition.

In this document, Alison suggests using the material and experience gained from the previous exhibitions in order to focus all her efforts on finally producing an event of public participation. The paperback documentation produced previously – i.e. *The Christmas Tree* (1976), *Calendar of Christmas* (1976), *An Anthology of Christmas* (1978), and *An Anthology of Christmas-Hogmanay* (1980) – is offered as a theoretical frame of reference. It was suggested that, as in the previous exhibitions, a group of students could be found to build the exhibition framework using 'the combined remains of the coloured structures of Cambridge and Edinburgh'.³⁹

She then shifted the focus of her research to the content of the exhibition: the public and their contribution, and how to ensure adequate support for the collective expression of the art of inhabitation. The success or failure of the exhibition will, therefore, depend on the visitors. As Alison suggests in the same paper, 'To be assured of success we need enough participants; we need the energy and creativity of children', and to achieve this she suggests collaborating with an educational establishment and including two aspects in its autumn-term course: event participation and exhibit

37 Come Deck the Hall: Paper 1. The Alison and Peter Smithson Archive, Harvard. The original paper is three pages long and starts with this fragment, which also appears in a very similar fashion in Alison Smithson and Smithson, *The Charged Void: Architecture*, p.546.

38 Despite Alison's great determination and efforts, this exhibition was never held. However, judging by the vast amount of background information, the handwritten notes with ideas for the exhibition, the sketches of the exhibition layout, and its role as another link in the series of Christmas exhibitions, just the preparation of this exhibition involved a thought process of great interest from the design point of view.

39 The structural framework was to consist mainly of red wooden battens with green wedges ('24 Doors') combined with white, silver, black and red latticed screens (Christmas-Hogmanay). In one note found in The Alison and Peter Smithson Archive at Harvard, Alison lists all the raw material (uprights, diagonals and battens) used for '24 Doors', beneath the title 'How to put together deck hall'.

making. The idea would be to give them the briefing documents: the paperback documentation and a sketch of the design of the structural framework they would find. This would enable the students to prepare their contributions during the term, knowing in advance what to expect. The exhibition organizers could then decide how and where the students' decorations would be situated when the exhibition took place, and could even reserve a space for each student, giving themselves some control over the end result.

As the decoration will be accretive, late comers might find they have the chance to make an on-site choice or adjustment, which they could do as a class group. Older students might be very able to make quite elaborate contributions... a set piece, models, a 'theatre', a structure, a mobile, paintings, a comic strip of the Christmas story or family celebration, a snowman, a Santa Claus, toys, gifts. But younger children – and members of the public – might expect their decorations be accomplished with the help of the invigilator.

Because of the participatory nature of the exhibition, the intention was for it to remain open to the public more or less all December. In addition, in keeping with tradition, this event of collective decoration was to coincide roughly with Advent. 'The putting up of the structural framework could form part of this time, as a priming activity to encourage public contribution.' The public's active participation in the decoration would gradually increase and accumulate, and finally culminate on Christmas Eve. At the end of this phase, it was also thought that it would be useful to be able to visit the exhibition for a few days to make the public more aware of their collective achievement. Each and every one of their small contributions would have been responsible for the look of the place, with the process being just as important as the end result.

The aims and devices of the 1981 Christmas exhibition designed by Alison were very clear, all that remained was to find a suitable venue and an entity willing to support it. The next document dated July 1981 seems to provide the answers: Bristol, the 35 King Street gallery, and once again university backing, in this case from the universities of Bristol and Bath.⁴⁰

The intellectual content of the exhibition was stated clearly in the first paper and the second paper simply added to it by focussing on more practical and specific considerations.

As regards the construction of the structural framework, it was mentioned that virtually nothing remained of the '24 Doors' exhibition, and that the Scottish Arts Council had used their structural framework to make crates. As a result there was very little material that could be recycled but the concept of the exhibition design would be the same: 'So that people can "deck the hall" we imagine a construction of a

40 Come Deck the Hall: Paper 2. The Alison and Peter Smithson Archive, Harvard.

There is some confusion about the dates because Alison signed this second document on 2 July 1982 but began by writing 'This, 2nd in response to your letter from 35 King Street, 29th June 1981.' Judging by the amount of extant documentation and her great efforts to organise this exhibition, it is unlikely that Alison would have taken a year to reply. It is assumed, therefore, that this is a mistake and that she took just 3 days. The doubt remains as to which of the two is correct: 1981 or 1982. In his article 'The Masque and the Exhibition: Stages Towards the Real' published in the *ILA&UD Yearbook of 1981*, Peter Smithson says: 'Next year, hopefully, "Come Deck the Halls" in Bristol', suggesting that it must have been that same year, 1981.

wooden, many branched hall.’⁴¹

Taking another look at the title, let’s now consider the different meanings of the word *hall*. According to the Oxford Dictionary, a *hall* is:

1. The room or space just inside the front entrance of a house or flat.
2. A building or large room used for meetings, concerts, or other events.
3. A large room in a mansion or palace used for receptions and banquets.
 - 3.1 *British* A large country house, especially one with a landed estate.
 - 3.2 The principal living room of a medieval house.

The folders related to the project contain photocopies of several pages from the book entitled *English Historic Carpentry*⁴² showing the wooden structures of some historic timber buildings in England including Priory Place, St Clere’s Hall, the Old Sun Inn, Jacobe’s Hall, Braxted Hall, etc. Almost all of them are medieval buildings (just one of them dates from the Renaissance), mainly from the last phase, the Tudor Period (c. 1450 to c. 1550). Together with these documents is also a photocopy of the design for the construction of an English timber frame house, the ground plan and two perspectives of the empty space of a medieval open hall, and a perspective of the inside of a manor house.

A close look at all this background information makes Alison’s sketches for the preliminary designs of the wooden, many-branched hall she mentioned in her answer dated July 1981 to the 35 King Street gallery far more eloquent.

In the second paper, Alison says that although ‘the bulk of the exhibits should be specially made, objects or displays, promised by schools, local groups or industries in the region.... a proportion of the exhibits would be ‘art’ items, of sufficient interest to make anyone’s visit worthwhile’, even going as far as to list such items and the institutions that would have to be contacted. A total of 18 items divided into 5 categories:

- (1-2) Art objects: mummer’s costume or ‘collection of papers’ from Blair Castle Museum or Museum in Bath to know about the history of Santa Claus. Some seasonal local pictures.
- (3-6) Promised, specially made displays: drawings or photographs of pantomime performance (Bristol and Bath theatre); advertising at Christmas of tobacco companies, something of celebratory history from local council of churches; Christmas toys.
- (7-9) Performances: films (loan from TV and The English Folk and Dance Society); a night of nativity plays.
- (10-14) Money earners: ribbons on a holly tree; envelopes, paper, stamps and a postbox of the GPO; a lucky dip; a candle-rack; posters and cards for sale
- (15-18) Funding: for part of the whole material, transport of both people and

41 Ibid.

42 Cecil A. Hewett, *English Historic Carpentry* (Phillimore, 1980)

things, time (universities of Bath and Bristol)

The long list summarised here reveals the great effort that Alison put into setting up each Christmas exhibition⁴³ and also the different approach to be adopted for the event on this occasion. Although the second draft of the exhibition project mentions more contents and not just contributions to be made by the public, the nature of the exhibition is the same: a collective celebration open to visitors of all ages, with a more popular slant that focuses not so much on traditions and history, as on the expression of a more everyday, inhabited Christmas. In this collectively decorated hall, there was room to sell things so fundraising ideas were suggested; an area was envisaged for items contributed by the public or local industries so that after visiting the exhibition, the public could stay to watch films or plays, etc. The hall, a three-dimensional wooden lattice, would enable many layers to coexist and overlap in a hands-on, shared experience of a collective achievement of quality of place through the quality of patterns of use.

43 The files in The Alison and Peter Smithson Archive at Harvard contain a great many handwritten notes by Alison about all these elements and different ideas for the exhibition. There is also a great deal of background information about wooden structures, costumes, new quotations and even a draft schedule for the exhibition.

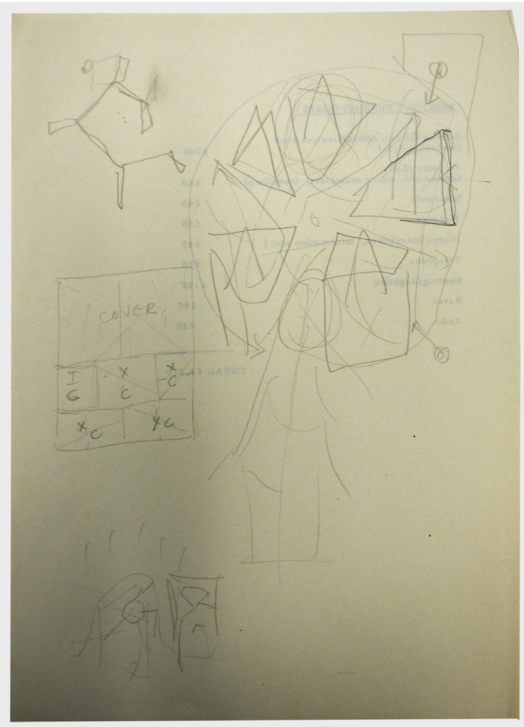
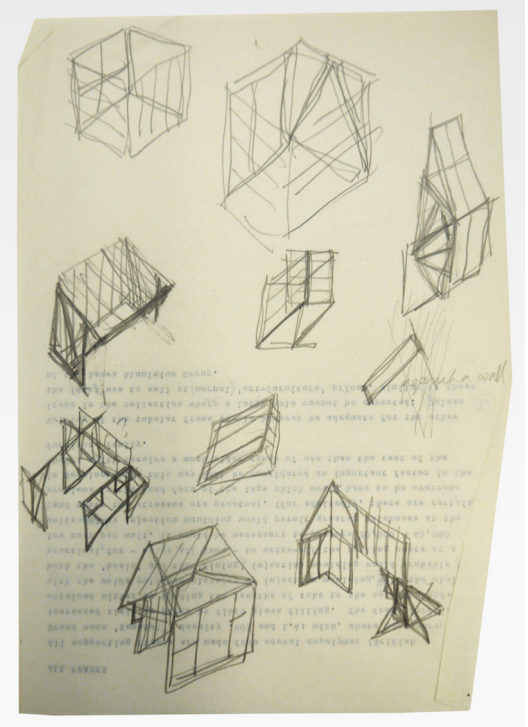
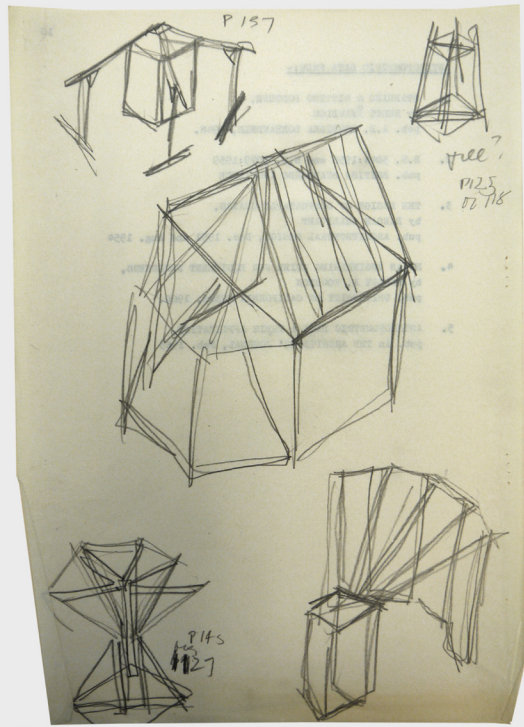

60 Sketch for framework of 'Come Deck the Hall'. AS.

61 Sheet of preliminary axonometric projections for framework design. AS.

62 Sheet of sketches for framework floor plan. AS (There is a floor plan similar to the structure of a medieval hall).

63 Braxted Hall. (p.209).

Page photocopied and filed by Alison Smithson from the book by Hewett, *English Historic Carpentry*.

64 Paycocke's House. (p.211)

Page photocopied and filed by Alison Smithson from the book by Hewett.

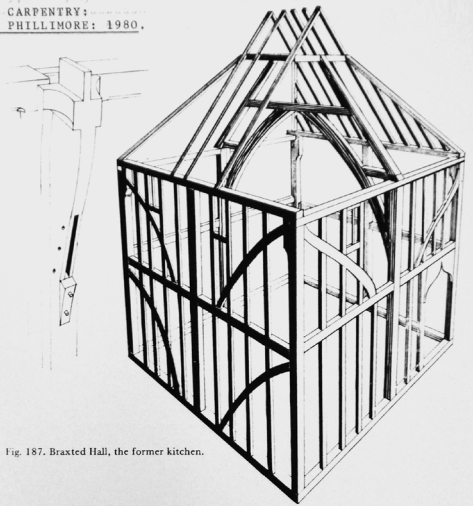

Fig. 187. Braxted Hall, the former kitchen.

The Medieval Timber Kitchen, The Hall, Little Braxted, Essex

This building stands within the moated enclosure of the former hall at Little Braxted, the present building occupying a site at some distance from it. The framing is illustrated in Fig. 187. It measures approximately twenty-two feet square and is about fifteen feet high to the eaves, and was fitted with an elaborate doorway and numerous windows beneath the eaves line. The roof is of the arched-collared type, with spur ties to the top plates, and dates to the closing decades of the 15th century. The interior is heavily encrusted with soot, apparently from the cooking fires, the site of which has not been established at the time of writing. The kitchen allegedly converted for use as a dovecote, presumably when the house was built further away and internal cooking commenced; but no structural evidence supports this claim. The storey posts are chamfered in two orders, as illustrated.

This deservedly well-known building forms the frontal range of an earlier complex of various dates, and its framing is illustrated in Fig. 189. John Paycocke, it has been suggested (G. F. Beaumont, 1840, 169), built the house, before 1505, when he died, for his son Thomas and his daughter-in-law, whose initials T.P. and M.P. frequently occur on the carved ceiling timbers (floor joists). Several important developments are illustrated here, perhaps the departure from the three-part plan of medieval houses being among the most important, although in this example the difference is not marked. The front elevation is possibly the best example of a Perpendicular house front, timber-framed and jettied with oriel windows. The carving is of stylistic interest since it is definitely Gothic, with, for example, a vine trail along the fascia of the jetty, and cusping of a crisp quality on the joists' undersides. The material prosperity of this family postulates the employment of a leading medieval architect and carpenter, as is evident from the style of the design, and such a man must have been well aware of the most efficient timber joints of his times; even so, just a few years before King's College chapel roof was finished, he used the beam with housed soffit shoulder (Fig. 295).

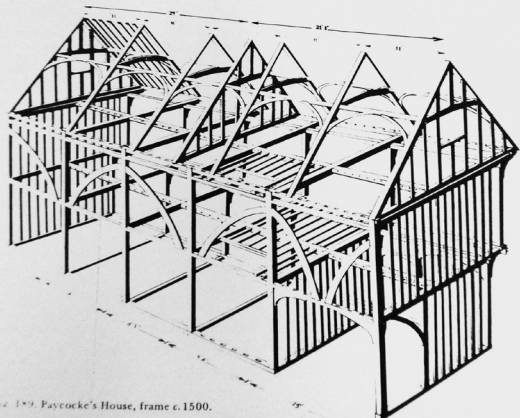
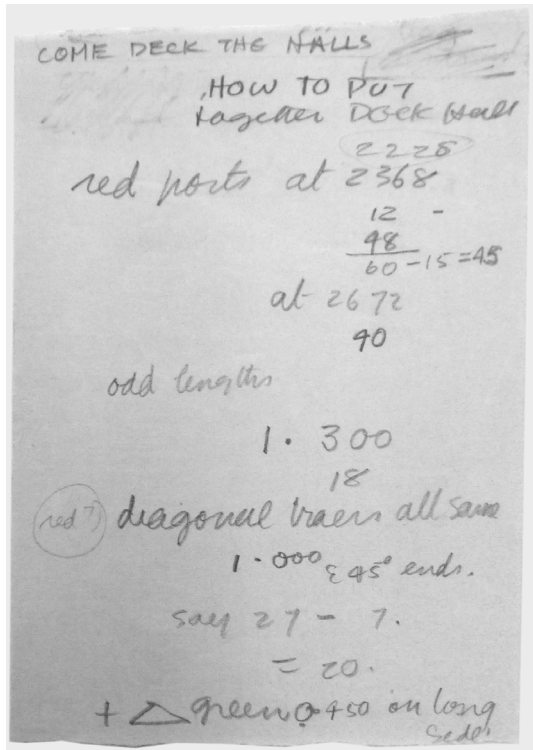
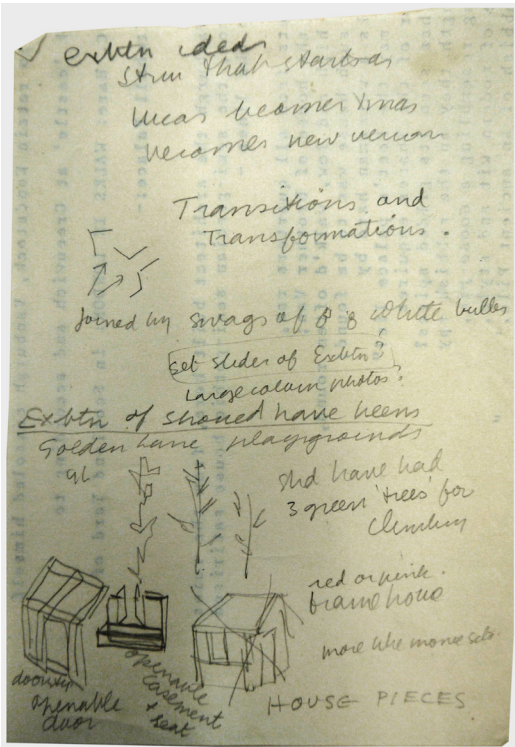
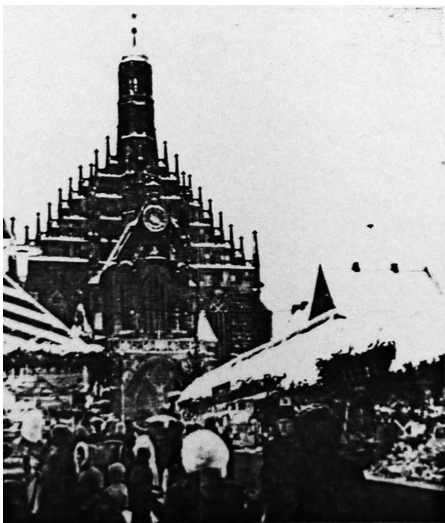
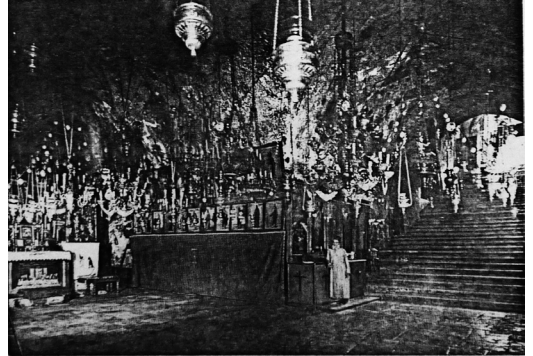

Fig. 189. Paycocke's House, frame c.1500.



65 Handwritten note by Alison with ideas for the 'Transitions and Transformations' exhibition.

66 Part of list of structural elements for the 'Twenty-Four Doors to Christmas' exhibition.



Background information for preparing the exhibition.

67 Star marking the site where Jesus is believed to have been born in the Grotto of the Nativity.

68 Grotto of the Nativity in the Church of the Nativity in Bethlehem, Palestine.

69 Interior of the nave of the Church of the Nativity in Bethlehem, Palestine.

70 Christkindlesmarkt. Nuremberg Christmas Market.

Christmas represents renewal... renewal is something that all Europe needs to know about to do with the fabric of cities: but for what lifestyle is this renewal to be for?⁴⁴

In one way or another, the four Christmas exhibitions analysed in this study are all linked to teaching and university. The Smithson's virtually uninterrupted contact with academia throughout their careers provided them with a sounding board for their most sophisticated, new and exciting ideas. This phenomenon was particularly obvious as of the last meeting of Team 10 in Bonnieux (1977) before it broke up following the death of Bakema, and intensified during the 1980s – the period when Alison entered teaching, and began giving seminars at universities outside England.⁴⁵ It was against this backdrop of thought and discussion in the academic world that the Smithsons had the opportunity to materialise some of the ideas they had been working on, in the exhibition 'The Entrance Made Festive'. The title of the seminar 'Signs of Occupancy' refers to the article 'Signs of Occupancy' which they co-authored in 1969 which was published in the *Architectural Design* journal in February 1972.⁴⁶ The article starts by reflecting upon the architectural language appropriate for the home – 'The ideal house is that which one can make one's own without altering anything' – and ends by commenting on the urgent need to apply this reflection to the city by tackling the challenge of 'facing up to the invention of a form-language of common use and the pleasures of common use for our period.'

The same concern also gave rise to the 'Wedding in the City' for the Milan Triennale in 1968, i.e. the on-going renewal of public places by events and the everyday decoration of the urban scene: a continuous transformation and appropriation of public space that they came to appreciate whilst strolling through London's East End in the 1950s with Nigel Henderson. Photos of children playing in the street and drawing hopscotch on the ground, banners flying, disguises and street parties on Coronation day, people gathering for funerals, etc. All this is part of the decoration of the urban scene and is the stuff that qualifies public space.

'Signs of Occupancy'⁴⁷ is also the title of a conference that Alison and Peter Smithson gave in 1979 in which they projected slides of the Smithsons' own work that illustrated signs of occupancy. The images are an example of how their architecture attempts to provide spaces for occupancy, and how occupation implies transformation, particularly in everyday life. The conference reveals how a unique

44 Alison Smithson, 'Sulla Trama Del Movimento Moderno', *Spazio e Società*, n. 20 (1982), 74–83. (p.77).

45 Alison taught at the Delft University of Technology (1982-83), the TUM (Technische Universität München) (1984-85) and the Universidad Politécnica de Cataluña (1985-86). Peter joined the ILA&UD workshop in 1974 (1974-2002), taught at the Bartlett School in London (1976-77) and at the University of Bath (1978-90).

46 Alison Smithson and Peter Smithson, 'Signs of Occupancy', *Architectural Design*, February (1972), 91–97.

47 Alison Smithson and Peter Smithson, *Signs of Occupancy* (Pidgeon Audio Visual, 1979).

object can renew a place and invite occupancy, creating a refreshing dialogue between object and user. The slides chosen to illustrate the conference are very reminiscent of images in the Eameses' film *House: After Five Years of Living* (1955) which documented the Eameses' life in the house and how they appropriated its structure. The influence of the Eameses on this approach is obvious. In a conversation with Hans Ulrich Obrist, Peter Smithson commented: 'You will not find vases with flowers in a Le Corbusier interior. [...] But Ray and Charles Eames made all of that respectable.'⁴⁸

Transitions and transformations

'The Entrance Made Festive' was the first of several attempts to materialise this conviction. The Smithsons suggested that Bartlett students put these ideas into practice by experimenting with different types of occupancy and collectively decorating a public space – the entrance to the school – and finding out first hand how deliberate collective occupancy can be used to renew a place. A pattern of occupancy that could even be considered to be an art form in itself: the art of inhabitation.

Christmas is the vehicle that the Smithsons chose to convey their ideas. Alison Smithson incorporated into the seminar the thoughts about Christmas that she had been working on for four years in order to draw clear parallels between a spontaneous phenomenon and her ideas for decorating the urban scene. Every year, Christmas decorations in the home and the city awaken many people's imagination, and are constantly renewed by the successive interpretation of different generations too. Alison and Peter Smithson also take part in this process, renewing themselves each year at Christmas time with new Christmas cards, wrapping paper, posters, Christmas trees, etc. – Christmas ephemera acting as mood carriers that often contain the seed of their subsequent work, as they themselves said on several occasions. This is particularly obvious in *The Shift*, a study which analyses such ephemera in depth.

The theme of 'decoration by events' was pursued again three years later after the '24 Doors to Christmas' exhibition. On this occasion, in addition to the decoration (now linked to the English way of celebrating Christmas), a framework was built for it: the lattice-frame and the cupboard doors. This was a magnificent opportunity to experiment in real space with an architecture which sought, in itself, to indicate and enhance use.

The Smithsons were 'entirely traditional to a certain sort of architect where reflection and construction go hand-in-hand',⁴⁹ and after the completion of St Hilda's (1967-70) and the Robin Hood Gardens (1966-72), came a period of almost ten years during which time they did not build a single project. Many of their projects remained on the drawing board – tenders they failed to win, unfinished projects, etc – leaving them unable to materialise the ideas they were working on. They lacked the input that construction experience contributes to reflection. This was the case of the

48 Peter Smithson and Hans-Ulrich Obrist, *Smithson Time: A Dialogue* (Cologne: König, 2004) p.13.

49 Alison Smithson and Peter Smithson, *Italian Thoughts* (Stockholm, 1993). "Set of Mind", p.101.

Kuwait Mat Building (1968-72), Lucas Headquarters (1973-74), Magdalen College (1974), Yellow House (1976), Landwehrkanal (1976), the Leafy Arbours over the Verbindungskanal (1977) and the Millbank Apartments (1976-77) amongst others. In the article 'Signs of Occupancy', they said:

What we would seem to be looking for is the gentlest of styles, which whilst still giving an adumbration of the measures of internal events and structures (rooms, activities, servicing arrangements, supports), leaves itself open to – even suggests – interpretation, *without itself being changed*.⁵⁰

The exhibition design finally submitted put to the test this desire in which the installation was to be a 'light touch of transformation without masking Kettle's Yard',⁵¹ an enabling frame (that did not interfere with the gallery layout) for the exhibits behind the doors. By means of these contents, Christmas was presented to the public like a collective achievement in decoration and place making. In this instance, the contribution of the architecture students from the University of Bath was to provide an inexpensive framework for the objects chosen to be displayed. The students were to take part in the debate not merely as users experimenting with the phenomenon of collective appropriation by providing decorations, but as part of a far broader reflection. The concern now focussed on how to foster this expression of the celebration by means of the exhibition installation itself. The students were therefore even invited to stay in Cambridge to construct the exhibition, and install and light the exhibits, in order to get them involved in the entire process.

The proposed lattice caters for the selected exhibits by providing a suitable support for each one whilst enabling visitors to appropriate and interpret the exhibition in different ways. Between the cupboard doors was the red wooden grove, a framework in architectural terms which was an essay on layering in which the structure and lattice were physically coincident for the first time. Until this point, the lattice had only been part of the layered composition of the façade, an overlapping element that blurred the façade's boundaries. This was the case of St Hilda's or Upper Lawn in which 'their gentle skin modulation seemed to offer themselves as lattices of various sorts... for the contributions of the seasons and the arts of inhabitation'⁵².

In theory, it was quite clear how these reflections could be incorporated into the configuration of space rather than just the façade: yet another step towards encouraging appropriation by users. Peter Smithson's conference at the ILA&UD in 1978, began with a firm conviction.

If a building is to give access to its occupants – access to its affections and skills – its design must

50 A Smithson and P Smithson, 'Signs of Occupancy'. An almost identical quotation appears in Alison Smithson and Peter Smithson, *Without Rhetoric: An Architectural Aesthetic, 1955-1972* (Latimer New Dimensions, 1973) p.69.

51 Alison Smithson, '24 Doors to Christmas'. In their own words: 'When we say that "lightness of touch" can allow a building to be interpretable we mean capable of being read in different ways by the occupiers so it becomes theirs without itself being changed.' Peter Smithson, 'Lightness of Touch', *Architectural Design*, June (1974), 377-78. (Lecture at Harvard in 1972).

52 Peter Smithson, 'Some Further Layers: Work and Insights', *ILA&UD Yearbook 1978*, 78-79.

have special formal characteristics. One way is through layering...for between the layers there is room for illusion, and for activity.⁵³

The moment they had the opportunity to put it into practice, in the form of a temporary structure for the '24 Doors' exhibition, they built their first example of lattice architecture: a red wooden grove. A new link in the thoughts they continued to think about and develop.

A year later, another opportunity – the 'Christmas-Hogmanay' exhibition – carried on with this research. The latticed frame was transformed into latticed cages, a series of fretwork panels that visitors could look through, multiplying and intensifying the idea of layering. The room for illusion and for activity became bigger and its boundaries became blurred, highlighting the potential of the intermediate spaces. In the Kettle's Yard installation, however, the boundaries between the outer sphere (the exhibition hall) and the inner sphere (the displays) were well defined thanks to the metaphor of the cupboard doors. An interpretation which could apparently be extrapolated to the city too thanks to the two-fold interpretation of the doors. This dual nature was obvious in both the exhibition poster and catalogue featuring not cupboard doors but house doors. As Peter Smithson said in parallel:

As the cupboard has its doors, so the house has its street-face. A face which like the cupboard door brings the miscellaneous contents of the house to the right level of attention in the town amongst the tens of thousand of things which require our attention.⁵⁴

Blurring the borders

After the experience of the '24 Doors' exhibition, the exact line between two spheres gradually became blurred and layered until it finally ceased to be a dividing line. As the outlines gradually faded away, they shifted from lines of exclusion to meeting places. Lines that changed into intermediate and intermediary layers, 'bridging elements', scaffolding⁵⁵ between the building and the landscape, inside and outside, user and weather, the private realm and the public domain.

At the same time, an inherent part of the dissolution of these borders was the gradual uncoupling of support and content. Whereas at the '24 Doors' exhibition the students were 'invited to consider how to provide an inexpensive framework for the objects chosen',⁵⁶ at the Christmas –Hogmanay exhibition the students were invited to 'make and furnish the spaces'.⁵⁷ The latticed framework is independent of the exhibits, there is no direct link between them. The lattices, frames and layered architecture experiment with feelings and with spatial perception: 'the lattice-frame and its potential for inter-layering running the gamut of different connotations

53 Ibid.

54 Peter Smithson, 'In Praise of Cupboard Doors'.

55 For Alison Smithson's definition of 'scaffolding' see 'Into the Air'.

56 Alison Smithson, *An Anthology of Christmas*.

57 Alison Smithson, 'Christmas-Hogmanay Exhibition'.

expressing the theme'.⁵⁸ The aim of the exhibition installation goes beyond simply housing objects in a display, it is not a matter of making a tailor-made suit, the aim is to create an atmosphere, in this case one that recalls the distinguishing features of the Scottish landscape. The lattices fade away, become more abstract, recall nature, the seasons, the weather, ...

Among specially made places where things might be seen or events happen [...] people will be able to explore their mixed inheritance of half-forgotten celebrations, or discover Scottish customs marking this pivotal season of the year when life needs its energies renewed.⁵⁹

The identification between the lattice and the exhibits is lost, the layering of spaces and lattices transform the installation into a receptive place. Among the layers of lattices are displays of the items that traditionally dressed the Scottish Christmas but this is also a place for receiving visitors, who are also invited to become part of the exhibition by simply being there: 'responsibility is returned to them for quality of use, for style of occupancy.'⁶⁰ There is room among the layers of lattices for illusion and for activity.

This differentiation between contents and framework will make it possible to achieve a long-lasting architecture able to adapt to users and their times. An enabling structure 'allowing us to do something, extending our capabilities',⁶¹ able to adapt to different moments and respond to different patterns of occupancy in which the inhabitant is always the leading figure. In response to the upsurge in postmodernism, the Smithsons called for an intense but easy-going architecture, an architecture without rhetoric based on Renaissance architecture.

The architecture of the Renaissance is rich in hooks and scaffolding; with hints of attachments to come, and jollities and seasons to be enjoyed. Such is not a past art... the arts of inhabitation are not lost, only dormant; needing an architecture thought-out so that as a consummation of their place people offer their own design gifts, as they do every year at Christmas.

The architecture of the long-lasting fabric needs to have formal characteristics which give access for the affections and the design skills of its inhabitants.⁶²

'Come Deck the Hall' was another step forward along this line of research. The proposal for the exhibition was a scaffolding acting as an enabling frame for hanging visitors' decorations on, and in which the structure is separate from the contents.

58 Alison Smithson and Smithson, 'Staging the possible' in *Italian Thoughts*, p.22.

59 Alison Smithson, 'Christmas-Hogmanay Exhibition'.

60 Alison Smithson and Smithson, *The Charged Void: Architecture*, p.471.

61 Alison Smithson, 'Into the Air.'

62 Peter Smithson, 'Some Further Layers: Work and Insights'. The first paragraph of this quotation does not match the article published in the ILA&UD 1978 Yearbook. It is an amendment of the paper Peter wrote in July 1979 (during the preparations for the '24 Doors' exhibition) which includes the reference to Christmas and the art of inhabitation which did not appear in the original. This amendment is a typescript which the author had access to at The Alison and Peter Smithson Archive at Harvard. Another of the modifications observed is the actual title of the article: 'Some further layers or the art of inhabitation: work and insights.' The inhabitant is obviously acknowledged at that time as the main layer of his architecture.

The format is no longer that of an exhibition but a public participatory event held by the host community. The inhabitants and their style of occupancy are responsible for the quality of the place. This exhibition would be a veritable event of collective achievement under the auspices of architecture. The installation of 'Come Deck the Hall', would have been the first attempt at what the Smithsons defined in 1974 as 'dressable' architecture.

When we say it should permit a building to be 'dressable' we mean capable of responding to occupiers or community seasonal or festival decorations, or to temporary changes, without the underlying structures or meanings being destroyed – in fact these structures and meanings being enhanced by such 'dressing'.⁶³

The tectonics of the frame

To enable people to deck the hall, the construction of a wooden, many-branched hall was proposed. In the folder containing background information for the 'Come Deck the Hall' exhibition, Alison kept photocopies of a few pages from the book by Hewett, *English Historic Carpentry* showing the bare timberwork structures of different historical English buildings which were apparently the underlying concept of the exhibition proposal. This book was published in 1980 but might also have been the inspiration for the frameworks for the Kingsbury Lookouts which they submitted for the 'Art Into Landscape' competition of 1977, or even the Lucas Headquarters project (1973-74) featuring a red structure which the Smithsons related to a framed house in the Warwickshire countryside mentioned in 'A History of Layers and Layering', a paper by Alison Smithson also dated 1980:

The Christmas exhibition was another way of replaying the red structure evolving in a green field space; a red carrying frame to the 24 doored boxes creating an internal Christmas landscape in which the repetition of elements, through variant spacing of upright red posts and triangular green bracing plates, created an infinite variety of form. The frame in turn became the Italian nativity stall; the timber ruin of the German painters in which the holy family camped; the framed house of the Warwickshire countryside – in which Lucas had its roots – so barely inhabited you might have expected something to be revealed; the redness up-dated the framework, its warmth renewing of our energies for our reinvention of Christmas time.⁶⁴

The structure, designed as a wood consisting of red posts and green bracing plates, brought the Lucas Headquarters project to fruition. For the first time it was possible to inhabit a lattice. What is more, one of the sheets of notes and ideas for the 'Come Deck the Hall' exhibition says, 'Lucas becomes Xmas becomes new version' / 'Transitions and Transformations' (fig. 65). Each Christmas exhibition is a variation

63 Peter Smithson, 'Lightness of Touch'.

64 Alison Smithson, *A History of Layers and Layering*. (Typescript) The Alison and Peter Smithson Archive, Harvard. An extraordinarily intense paper in which Alison reviews the different interpretations and the importance of the layering strategy in her work. The final version was published in Italian in 1981 in the *Spazio e Società* journal (Alison Smithson, 'Layers and Layering.') Whenever possible, reference is made to the original typescript in English to avoid any possible loss of meaning in the translation.

of a single project therefore the background information about the last exhibition might have been the background information which had been dragged about and selected, but which had been under consideration for almost ten years.

This folder for the 'Come Deck the Hall' project also contained examples of the bare timber structures of some historical English buildings, as mentioned earlier, together with images of the Church of the Nativity in Bethlehem and the Nuremberg Christmas Fair: the religious side and the pagan side, the most orthodox and the most everyday. The image of the grotto where Jesus Christ is believed to have been born was used in 1976 to illustrate the paper entitled 'Calendar of Christmas'. The candles and oil lamps typical of the orthodox church, which symbolise the light of the world and which dress and decorate space, are good examples of signs of occupancy. The image of the ceiling of the basilica, a large *hall*, shows a fifteenth-century timber structure, like most of the images borrowed from Hewett's book, that covers the entire building.

Finally, this folder also contains an image of the *Christkindlesmarkt*, the Nuremberg Christmas fair, related to the German *Christkind* tradition. This fair, held since at least the seventeenth century, is the basis of Nuremberg's Christmas celebrations. Christmas fairs are traditional in many different places but they all have one thing in common: the outward appearance of their temporary structures, the stalls. The traditional market stall, like the historic representations of the Nativity stall, are timber structures ready to be occupied, the framework for the art of inhabitation. It is no surprise that they were used as a reference when designing the Christmas exhibitions: Alison pointed out that the structure of the '24 Doors' exhibition was 'akin to a traditional Christmas arcade'. Moreover, the first display at the opening of the exhibition was 'the nativity Stall/Christ/Market Stall – the cross reference in European painting represented by an Italian painting'⁶⁵ – a metaphor that could introduce another theme, the layering of meaning.

It must also be said that the Christmas exhibitions all feature structures made of wood: wood that suggests the stalls, wood as a material with architectural properties of its own, wood able to form the structural framework of a building, and also wood as a symbol of things provisional: a stage-architecture.

The architects in the first three generations of the Renaissance established ways of going about things which we unconsciously follow... first the architectural idea is sketchily stated as a diagram or a design fragment then 'after nine months', the wooden model. Subsequently the working-drawings and the shop-drawings and so on; all as today.⁶⁶

This *modus operandi* is perfectly obvious in the Christmas exhibitions, which were not merely the staging of the architecture on the drawing board at that time (and which never came to fruition), but the laboratory enabling them to conduct experiments and carry on thinking until they finally materialised their architecture, as part of the same process, in the following decade, the 1980s. A decade also

65 Alison Smithson, '24 Doors to Christmas'.

66 Peter Smithson, 'The Masque and the Exhibition: Stages Towards the Real', *ILA&UD Yearbook 1981*, 62–67.

characterised by on-going reflection and experimentation – then with support from the furniture manufacturer Axel Bruchhäuser. This collaboration began in 1984, when the Smithsons were commissioned to build the Kingsbury Lookout for Bruchhäuser's so-called *Hexenhaus* (witch's house), and continued in many different spheres within an unusually close-knit and life-long architect-customer relationship.

The first projects for Axel Bruchhäuser, and also the first projects to be built after the Smithson's construction doldrums that began in the early 1970s, were the Yellow Lookout (1984-1991) at the TECTA Factory and Axel's Porch, Alison's project at the house in Bad Karlshafen (1984-86). The direct link between the Yellow Lookout built at Lauenförde, in the gardens at the TECTA furniture factory, and the Straight Climb Lookout devised for the Kingsbury Water Park in 1977 as part of the Art Into Landscape competition, is patently obvious. The original commission was to build the Yellow Lookout in the woods around Bruchhäuser's house but in the end it was decided to build it in the courtyard in the factory gardens as a place for workers to go during their breaks, a place that suggested from the outside the existence of the court within. A sign of occupancy, a bridging element between the factory and the landscape, and a place waiting to be dressed by the inhabitation of its users and the seasons.

Its interwoven, yellow structure is considered to be the last link in the line of research into *treillage'd space* that began with the timber lattices of St. Hilda's College, continued with the Lucas Headquarters project, was subsequently tried out in the 'Twenty-Four Doors To Christmas' exhibition⁶⁷ and finally brought to fruition more than fifteen years later with the Yellow Lookout. Transitions and transformations that write the storyline of the period from the late 60s to the early 80s.

In the paper submitted with the proposal for the Kingsbury Water Park competition in 1977, Alison suggested:

Coinciding with the effect in Warwickshire of Dutch elm disease, the scheme proposes to use the resultant 'bonanza' of timber lavishly in large sections to make viewing structures that allow visitors to view the water park from various levels.

A scaffolding structure enabling people to look at, but not interfere with, the essence of the place, with a 'lightness of touch'. The reference to Warwickshire and the timber structure appears once again. The proposal suggested building coloured lattices out of the structural timbers, a device tried out subsequently in each Christmas exhibition because colour also contributes to the perception of layering.

Not just a white Christmas

Another look at the comment about the '24 Doors' exhibition made in the essay 'A History of Layers and Layering' reveals that colour is mentioned too: 'the red structure evolving in a green field space [...] creating an internal Christmas landscape [...] the red frame was also a line of trees reborn, meandering into the distance as in a landscape; a line returning on its self, making a place in the red structure, advancing again and promising a safe journey's-end to the small child who enters in

67 Alison Smithson and Smithson, *The Charged Void: Architecture*, p.379.

this seeming forest of red posts'. The colour of the layering is used to indicate and enhance use, and participates as a layer of meaning superimposed on all the others. The metaphor of colour used for the Lucas Headquarters – in which the latticed structure linked the building to the landscape and instigated a dialogue between the green plane and the surrounding trees – is used in this instance too.

However, to boost the depth and overlap possibilities of layering, and without taking into account the substance of the material, the Lucas Headquarters project submitted at the 'Art Net' exhibition featured more colours: red, blue, green and brown. The device of reflection and the play of reflection, with one plane interacting with another, was similar to the one seen a long time before in Hunstanton: 'Layering was first seen by us in Hunstanton – watching the structure go up, the colours [red, black, silver] of its various coats applied.'⁶⁸ The formula is similar to the one used in the 'Christmas - Hogmanay' exhibition too, in which the 45° lattice in a single direction recalled seasonal layers: shimmering silver lattices like the northern rain; white lattices evoking the snow; black lattices, the night, whilst also providing an environment of mysterious and shimmering layers of expectancy amongst which the objects that dressed the celebration were displayed.

Due to the dearth of information about the 'Come Deck the Hall' exhibition, it has not been possible to determine its colour range. One note apparently mentions a 'red or pink frame house', but it is difficult to endorse this because these are simply preliminary notes. What is, however, clear is that it would have meant something in order to prompt the appropriation of the structure by its users, as was the case for example of the outer layer of untreated oak at St. Hilda's (pale grey when dry, and brown when wet): an outer element in a dialogue with the atmosphere, the seasons and the creeper; the bright colours of the Kingsbury Lookouts which emphasised that structures were for people's enjoyment; and subsequently the layering of the Waterlily/Fish writing desk.

Time for renewal

Finally, taking another look at the previous quotation about the '24 Doors' exhibition, its final words were: 'its warmth *renewing* of our energies for our reinvention of Christmas time'. Christmas represents tradition but also represents *renewal*. Continuity and renewal, transitions and transformations – all constants in the Smithson's thoughts.

It was a family's energy through three generations that we tried to harness through our three Christmas exhibitions... through each individual, by means of ephemera of celebration and decoration, to awaken society's sense of its own power, to take responsibility for the look of places. First within the home's space the internal mood is *renewed*; then something, a signal is shown to the outside, which *renews* external space, its mood, the sense of togetherness.

In our concern for *renewal* our work has been like an embroidery on the canvas provided by the heroic period of the Modern Movement... if the needle in sewing has seemed to move away from the canvas, it returns, each time tracing in the air our consideration of our two-generation inheritance. [...] our century's 'fresh beginning' was made by the few who remained from the

All these exhibitions mention the need for renewal. The Signs of Occupancy seminar which provided the framework for 'The Entrance Made Festive' exhibition was 'concerned with the nature of the public domain, its *renewal* and its decoration'. The aim of the '24 Doors' exhibition was 'to encourage a *renewal* of our arts of inhabitation'. 'Christmas – Hogmanay' celebrated renewal in order to '*renew* communal confidence in the stylish use of places outside the home'. 'Come Deck the Hall' encouraged people to participate in setting it up in order to '*renew* the sense of collective responsibility for the look of places'. This conscious renewal also characterised their thinking in the same period (1976-1981) – a time of reflection and renewal that led to the change of attitude reflected in *The Shift*, an essay of 1982, and which was to be embodied in their definition of Conglomerate Ordering in 1986.

In 1972, in the book entitled *Without Rhetoric*, they expressed their concern for style and composition. They ranked it equal with Le Corbusier's *Vers une Architecture* for they were searching for an interpretation of the past that would enable them to produce a definition of aesthetics in keeping with their time. But in the pages of *The Shift* (1982), they radically shone the spotlight on people, on appropriation possibilities, on layers of occupation and, in short, on the arts of inhabitation. In the same way as when studying the Christmas exhibitions, the essay embraces two lines of research that now coincide: the experiment begun at St. Hilda's where users and seasons were invited to participate in the game of architecture by means of the language of lattice and layering; and the conviction that life was indeed the stuff and decoration of the urban scene, the message they tried to convey in the 'Wedding in the City' exhibition for the Milan Triennale of 1968.

To a greater or lesser extent, these two ingredients shape the idea put forward in each Christmas exhibition. A necessary renewal because 'a very great shift of mind was required if a formal language was to be found that could activate, not merely support the dressings and interpretation of things and places'⁷⁰. A change that also needed to awaken society and make it responsible for the look of places and able to implement the arts of inhabitation. *The Shift* ends by pointing in this direction:

Yet the money and the skills – which make it possible to see the familiar in a new way and so to tune one's house; or order up a new house to match the mood of the time; or change one's style of eating or moving; or decorate a room for family seasonal events – have come within the reach of almost the whole of the society. It is to these people that architecture must now offer itself – to their nascent skills in the art of inhabitation. In this spirit the design of the Lucas Headquarters, 1974, was offered, and the Yellow House, 1976, and the House With Two Gantries, 1977, waiting to be decorated; we have come a long way from our first plea for the ordinary things of life to be considered as the stuff and decoration of the urban scene in 1952.

The shift has taken place.⁷¹

69 Alison Smithson and Smithson, 'Staging the possible' in *Italian Thoughts*, p.22. These concepts were enlarged upon in the paper by Alison Smithson, 'Sulla Trama Del Movimento Moderno'.

70 Alison Smithson and Smithson, *Alison + Peter Smithson: The Shift*, p. 61.

71 *Ibid*, p.72.

The thinking that underpins each Christmas exhibition is a reflection of this change in attitude. Surprisingly, the exhibitions are not mentioned in the essay, and yet the experiments tried out in each one are the basis for the concept addressed in *The Shift*. 'The Entrance' is the exhibition with the narrowest scope for its only visitors were the students from the school of architecture. '24 Doors', despite also having close links to the university, opened its *doors* to the general public in an attempt to make them assume their responsibility for both the need to renew Christmas decorations and the quality of the outcome. 'Christmas-Hogmanay' moves one step further by making the visitors themselves part of the exhibition's decoration, thereby making them aware of their responsibility for the quality of use and the style of occupancy. Finally, 'Come Deck the Hall' would have been the most ambitious exhibition by providing just a framework and leaving all the responsibility for decoration and, indeed, the quality of the outcome of the collective inhabitation of the structure by its users. *The shift has taken place.*

Into real life

'Come Deck the Hall', for which a many-branched hall waiting to be occupied was envisaged, came to fruition when Axel's Porch was built in 1986 at the Hexenhaus in Bad Karlshafen. Like a successive approximation of the process, they managed to construct for the first time:

- ... a building which can be dressed;
- ... a building which builds its meaning in time;
- ... a building which makes many people active.⁷²

From a formal and material viewpoint, Alison's sketches for the 'Come Deck the Hall' exhibition based on the bare timber structures of the historical English buildings portrayed by Hewett, resemble the lines also drawn by Alison to define the timberwork of the Hexenhaus porch. Even the intention leaving the original structure of the house bare in order to link it to the surrounding landscape is related to the analysis of these historic buildings once stripped of their heavy roofs and walls.

For Axel's Porch, Alison designed a branching latticed structure that incorporated the poetry of tree branches as a layering device, generating a receptive architecture that made sense once inhabited. An enabling frame that does not mask the original house but enlarges the relationship between its users and the landscape, a bridging element with a 'lightness of touch' that celebrates the in-between and can be interpreted in countless ways. A collective achievement of occupation, a place for the arts of inhabitation. An early example of the architecture of renewal that they defined that year, in 1986, as the architecture of conglomerate ordering⁷³.

72 Alison Smithson and Smithson, *The Charged Void: Architecture*, p.420. This quotation is taken from the description of the 'House with Two Gentries' project but can be extrapolated entirely because it is yet another exploration of 'layering'.

73 The concept of 'conglomerate ordering' was formulated for the first time in the article 'On the Edge'. (Peter Smithson, 'On the Edge', *ILAE&UD Yearbook 1984*, 60–63..) and developed two years later in the article 'Conglomerate Ordering' (Peter Smithson, 'Conglomerate Ordering', *ILAE&UD Yearbook 1986*, 54–59).

The sort of building that appears to suit our needs and respond to the complexity and changeability of its 'functions' – offering an ability to include in its 'order' continuous change – the building developed from the inside outwards – so that when it is materialized, our recognition of it: 'so that's what it looks like' – is the conglomerate building.⁷⁴

This renewal, canonised as 'conglomerate ordering' and tried out when setting up the Christmas exhibitions, was a fresh beginning, the shift that made way for the fourth generation of modern architecture in the 1980s. Its main mission was to signal the changes of use by incorporating devices and decorations, by integrating into the architectural creation the appropriation by its users, or in other words, by superimposing layers and lattices⁷⁵. A fourth generation that the Smithsons mentioned in the essay *Conglomerate Ordering* and which they added to the previous three generations⁷⁶ when they edited some of their articles published previously in the *ILA&UD Yearbook* for a 1993 compilation entitled *Italian Thoughts*⁷⁷.

Likewise, the start of the third generation was also marked by a new beginning, in this instance, the sense of renewal embodied by the 'Parallel of Life and Art' exhibition in 1953.

Among architects of our present third generation the beginning of a new awareness as to placement, a new responsiveness, began in the nineteen fifties with the desire for new imagery... the image-landscape of 'The Parallel of Life and Art'.⁷⁸

This exhibition – with its structure characterised by the layering of images and its celebration of the 'as found' aesthetic – is also mentioned in the chapter *Staging the Possible* as a precedent of Axel's Porch: possibly because both works were a new departure within the legacy of modern architecture, an affirmation of 'a society reconsidered so that people acknowledge a new beginning, as a bride is dressed and as a "white" Christmas is offered as a symbol of renewal'.

74 P Smithson, 'Conglomerate Ordering'.

75 Alison Smithson and Smithson, 'Staging the Possible' in *Italian Thoughts*, p.23.

76 See Peter Smithson, 'Three Generations', *ILA&UD Yearbook 1980*, 88–95; P Smithson, 'The Masque and the Exhibition: Stages Towards the Real'.

77 Alison Smithson and Smithson, *Italian Thoughts*.

78 *Ibid.*, p.30.

Images Sources

London, Smithson Family Collection. (fig. 4-9, 30-33, 35-43, 46-47)

Harvard Design School, Frances Loeb Library, Special Collections Department, The Alison and Peter Smithson Archive. (fig. 10-13, 15-16, 20-22, 25-29, 34, 44, 45, 48-51, 55-70)

Alison Smithson and Peter Smithson, *Alison + Peter Smithson. The Shift*, Architectural Monographs no.7 (London: Academy Editions, 1982). (fig. 1-3)

Alison Smithson, '24 Doors to Christmas', *Architectural Design*, 1980, 177-78. (fig. 14)

Franck WithFord, 'Christmas Remembered...,' *Cambridge Evening News* 10 December 1979. (fig. 19)

Alison Smithson and Peter Smithson, *The Charged Void: Architecture* (Monacelli Press, U.S., 2001). (fig. 17, 18, 52-54)

Astragal, '24 Doors to Christmas', *Architects' Journal*, 1979, 1242. (fig. 24)

Alison Smithson, 'Into the Air', *MASS. Journal of the School of Architecture and Planning*, VII (1989), 7-10. (fig. 23)

TECTA Exhibitions

Cologne International Furniture Fair (1984)

10 Years of Stefan Wewerka in TECTA, 1975-1985 (1985)

The Future of Furniture - Furniture of the 4th Generation (1986)

Saint Jerome: The Desert – The Study (1991)

Modern Architecture Has Been with Us for Four Generations (1992)

TischleinDeckDich a.s.o. (1993)

Cologne International Furniture Fair (1995)

On the Floor Off the Floor (1998)

Lattice Furniture Stand (1999)

Popova's Chair Exhibition (2000)

Flying Furniture (2000)



Who is Lecta TICHGIND WOVEN CHAIRS
BANK
BALANCE

- 1 'The Hesitant Car'. Toy designed by Hermann Finsterlin.
- 2 Alison Smithson's view of (real) life in TECTA. 1993.

The long, close collaboration between TECTA, the German furniture manufacturer famous for its handmade, tubular-steel chairs, and Alison and Peter Smithson began strictly as a business arrangement when they signed an agreement in 1983 for the production of designer items. A few years earlier in late 1980, Stefan Wewerka, then an advisor to TECTA, had put the proprietor of TECTA, Axel Bruchhäuser, in contact with the Smithsons, whom he had met at the first meetings of Team 10.² Wewerka wanted to enlist other architects to work on developing furniture design and Bruchhäuser was interested in producing several of the Smithsons' pieces of furniture that had not got off the drawing board, such as the Trundling Turk armchair of 1953.³ All of this culminated in the fruitful collaboration between the Smithsons and TECTA.

On 2 May 1984, a letter marked 'top secret' signed by a cat called Sir Karl was sent to another cat, Snuff Smithson. This was the start of another special, thought-provoking relationship between TECTA and the Smithsons which gave rise to a series of projects at Bruchhäuser's house (the Hexenhaus) and the TECTA factory in Lauenförde, but which above all paved the way for a customer-architect relationship of unusual quality and complicity no longer merely on a business footing.

At the beginning of the letter Sir Karl introduces himself to Snuff as the representative of 'TECTA – comMerz, I.L.' This play on the words *com(merce)* and *Merz*⁴ (the works of art by Kurt Schwitters) reflects and conveys to the Smithsons first of all the duality underlying both the philosophy of the TECTA factory and its owner, Axel Bruchhäuser. The entire letter is an intriguing puzzle of interwoven ideas in which everyone involved has an alter ego: Axel Bruchhäuser (Karlchen), Alison Smithson (Snuff) and their common friend Stefan Wewerka (Steven Squirrel, i.e. the

1 Peter Smithson in Axel Bruchhäuser, *Der Kragstuhl / The Cantilever Chair* (Berlin: Alexander Verlag, 1986), p. 86.

2 Wewerka first met the Smithsons at the CIAM IX in Aix-en-Provence (1953) and, thanks to Georges Candilis, began to attend the Team 10 meetings in 1960. From then onwards, Wewerka only took part in these meetings sporadically and yet in 1980, Alison described him as part of the Team 10 'family'. See Max Risselada and Dirk van den Heuvel, eds., *Team 10: 1953 - 81; In Search of a Utopia of the Present* (Rotterdam: NAI Publishers, 2005).

3 Stefan Wewerka, ed., *1972–1982. Bericht Einer Deutschen Unternehmung* (Berlin: Alexander Verlag, 1983), p. 57.

4 *Merz* is the word coined by Schwitters in 1919 for a large group of creations ranging from written texts to drawings, paintings, collages, typographies and three-dimensional constructions. The word does not mean anything but was used as a generic term to describe what he intended to produce: work based on the association of artistic and non-artistic materials in search of a surprising new plastic language. He used old things as the material for new works of art in the sense of experiences that bring together and link up any type of materials, including both those used by artists and those belonging to the everyday world. <http://www.educathysen.org/capitulo_3_kurt_schwitters> [accessed 12 August 2014]. Our translation.

English translation of his name).

Thus began an intimate, personal, playful and particularly creative correspondence between the two cats and their owners which was to change the dimension of their relationship from then on. As Axel Bruchhäuser said, ‘empathy was the base of our cooperation which began with the “top secret” letter from Karlchen to Snuff, asking for a Yellow Lookout in 1984...a.s.o.’⁵

Alison replied personally to this play on words invented by Axel in 1984 with another cryptic message in 1993. At the bottom of one of her letters to Bruchhäuser about the ‘Tischleindeckdich a.s.o.’ exhibition stand, she wrote ‘This is TECTA’ which she explained by adding a drawing of the Hesitant Car, a toy designed by the German architect Hermann Finsterlin in the 1920s. As can be seen in figure 1, the hesitant nature of the toy car was a categorical statement of company’s philosophy: TECTA is both the woven chairs and the *tischlein* which Alison shows merging together to create a bank balance.⁶ A new state of business equilibrium that also tallies with the status ‘I.L.’ (in liquidation) mentioned by Sir Karl in his first letter almost 20 years earlier when he introduced himself to Snuff as the ‘TECTA – comMerz, I.L.’ representative.

The TECTA exhibitions analysed in this chapter are a good example of this dual nature. Firstly Alison, until her death in 1993, and then Peter, until 2003, helped and advised Bruchhäuser about his annual participation in furniture fairs (mainly the international furniture fairs of Cologne and Milan): merely trade showings in which the Smithson always tried to include at least some reference to the *Merz/Tischlein* aspect. There was, however, also room in this collaborative relationship for displays of a far more thought-provoking nature, such as the ‘Tischleindeckdich a.s.o.’ exhibition, whilst not forgetting that the client was a furniture manufacturer – albeit a rather unusual one. As a result, furniture was always the epicentre of the concepts embodied by the exhibitions analysed below. Furniture that talks about architecture.

The year 1984 was the start of this new venture for TECTA, Axel Bruchhäuser and Sir Karl, and also of the extremely productive and creative final stage of the Smithsons’ work. This was the year when the projects at the Hexenhaus and the factory began, and when they began to dabble in furniture design as a result of these new concerns in common, and also the first time they worked together for an exhibition: the Cologne International Furniture Fair. Alison and Peter Smithson had finally found the right breeding ground to materialise many of the ideas they had been working on.

5 Bruchhäuser, Axel (2014, June 6). [email to the author]. The meaning of a.s.o. will be revealed later.

6 The ‘woven chair’ refers to the famous Weissenhof chair (1927) by Mies van der Rohe, i.e. the wickerwork chairs handmade at the Lauenförde factory, which by extension also refers to all the handmade, avant-garde furniture made by TECTA to extremely high standards of quality. The *tischlein* (small table) refers to the TischleinDeckDich table, an experimental table design being developed at that time by Alison Smithson in conjunction with TECTA. This table was to be the focal point of the ‘Tischleindeckdich a.s.o.’ exhibition addressed at length later in this paper.

2.05.84

01

Top secret

From: "Sir Karl" c/o TECTA - comMerz I.L.

To: Snuff Smithson (Team one)

I want to ask my butler Axel to built ~~upemmethe~~ Kingsbury Lookout for our so called "Hexenhaus". Stefan Wewerka has made the floors (not made, "painted!!"): with Jean Prouvé Axel constructed a "balcony" (to go directly from the first floor in the tree). Now we need 2 lookouts, one for me and Mr. Steven Squirrel (to look for mouses and to smoke thick cègars, thinking on Mies), the other red one with the green head for our garden tools and the birds.

If you agree to do that, we want to know if it was planed to built the first lookout in raw wood and without a green roof and the red one without a staircase? (Our reconstructed measurement is ca. 1,80 by 1,80 by 5,40 m 1:10 for the first lookout.)

The trundling turk 2 (or San Diego chair?) looks fantastic. we will begin to built it soon (perhaps we can use your prototype?) Does the fabric comes from JAB too, if yes which name it has?

The glass tank we prepared in the meantime for the lantern tree; thank you for your help!

Regards to the other Smithsons

"Woodcount Karl"

ppa. 



4 The Trundling Turk, collage. PS, 1954.

Cologne International Furniture Fair (imm Cologne)

Alison and Peter Smithson

1984

Event, venue and dates: imm Cologne. Kölnmesse (Cologne trade fair complex), Cologne. 17-22 January 1984.

Organizers: TECTA

Design: Stefan Wewerka

Work team: -

Gross floor area: -

Itinerary: -

Exhibition catalogue: -

Related publications: -

Additional information: -

Smithson exhibition:

Trundling Turk. Alison and Peter Smithson, 1953

Red boxes (The Economist). Alison Smithson, 1964

Reviews: -

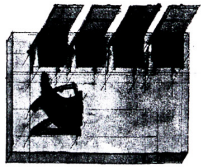
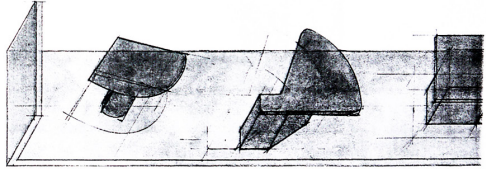
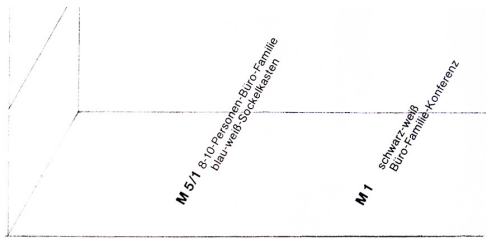

Jean Prouvé



Marcel Breuer

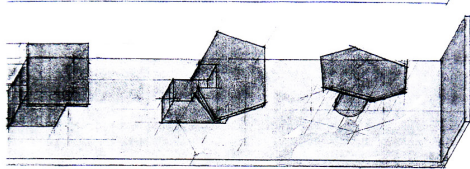
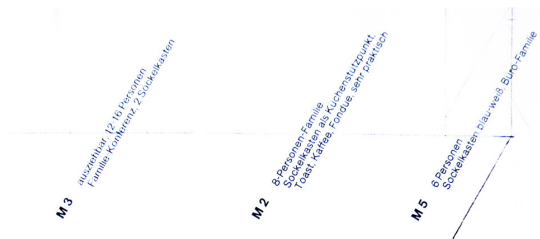

A & P Smithson



Stefan Wewerka



5 and 6 TECTA furniture catalogue (inside pages). 1984.

7 Invitation to the *Die Moderne* by TECTA exhibition and opening speech at the Gunter Rambow gallery and the City of Güstrow museum. 2008.

The 1984 Cologne International Furniture Fair was ТЕСТА's first public showing of furniture designed by Alison and Peter Smithson. The Trundling Turk armchair and the Red Boxes of The Economist were exhibited on a stand designed by Stefan Wewerka along with other pieces of furniture by Jean Prouvé, Marcel Breuer and Stefan Wewerka himself.

Also on show on this impeccable trade stand alongside the tables, chairs and cabinets designed by these famous architects were accessories by Wewerka himself and El Lissitzky plus items by other foremost designers such as Germany's Richard Sapper and Italy's Achille Castiglioni.

The Trundling Turk armchair was the first piece of furniture designed by the Smithsons and was also the first to be manufactured by ТЕСТА. It was designed between 1953 and 1954 in response to the need for furniture in keeping with the new style of architecture they were creating. According to *The Shift* it may have been whilst making the first sketches for the Burrows Lea Farm (1953-1954) or the perspectives for the Chance Glass Advertisement (1953) that the Smithsons became aware of the problem:

...what was to be put in as furniture? We needed objects that achieved a cultural fit [...] the chair that belonged to the present occupiers not to the building... [...] As a response to the realisation came the Trundling Turk, a chair which looked as if it might follow its owners from room to room and out onto the beach.

That armchair was yet another aspect of the Smithsons' approach that paved the way for reinstating a sense of identity, one of their key concepts in the 1950s.⁷

The special edition of *Arena* dedicated to the Smithsons in 1966, describes the Trundling Turk as the 'chair designed by Smithsons but not yet made'. *Not yet* possibly because although this chair had been designed more than twelve years earlier, its inherent concept was still valid in 1966 – and in 1984 too.

Nearly all modern chairs are perches. They are bright rather than deep. For chatter rather than leisure. They are impermanent in appearance and quickly shabby. They can usually be used for only one purpose and in one anatomical position.

The traditional leather upholstered club chair is the antithesis of this: comfortable, permanent, multi-purpose and multi-position. This new chair has all these qualities.⁸

A chair that can be used in many different ways to facilitate its appropriation by different users but with a very simple structure: 'Basically it consists of a completely independent upholstered seat, back and arms, so constructed that the addition of four tubes makes a uniquely elegant chair...'⁹

7 That same year, 1953, Alison and Peter Smithson presented their radical 'Urban Re-Identification' proposal at the CIAM IX in Aix-en-Provence intended to replace the traditional four categories of the functional city – living, working, circulation and recreation – by others based on different levels of human association: the house, street, district and city.

8 Alison and Peter Smithson (1953) quoted in Peter Smithson and Karl Unglaub, *Flying Furniture: Unsere Architektur Rollt, Schwimmt, Fliegt = Our Architecture Rolls, Swims, Flies* (Cologne: König, 1999), p. 22.

9 Jeremy Baker, 'A Smithson File', *Arena*, 81 (1966), 179–218 (p. 189).

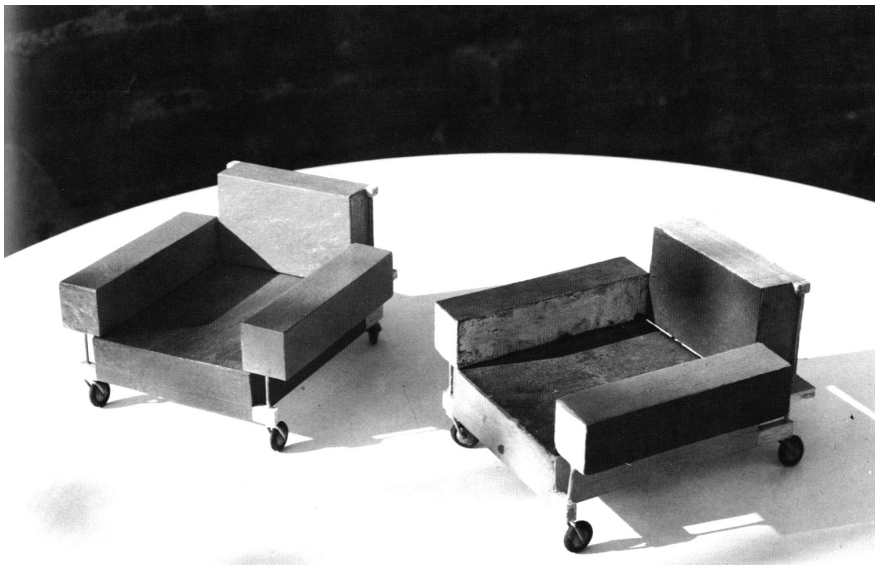
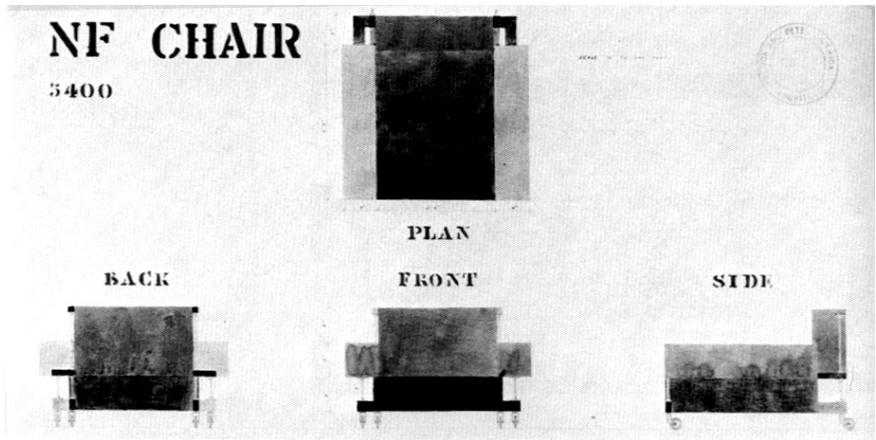

8 Plan and elevations, 1954.

9 Mock-up (Photo: John Maltby).

10 TECTA version, 1984.



Advantages:

1. Warm.
2. Cups, plates, etc., can be rested on the arms.
3. Any sitting position can be adopted.
4. It is intended to accommodate cushions.
5. Hairpins, knitting needles, etc., cannot be lost.
6. Really comfortable for whole day's reading or study.
7. Can be moved with ease.
8. Can be moved anywhere – hotel, ship, terrace, fireside – house or palace.
9. Does not tip up when arms sat or stood on.
10. Trays, etc., can be balanced on it without fear.
11. Has the pertinency and impact of a Steinberg drawing.¹⁰

10 Alison and Peter Smithson (1953) quoted in Marco Vidotto, *A + P Smithson: pensieri, progetti e frammenti fino al 1990* (Genova: Sagep, 1991), p. 18.



11 Saul's Steinberg drawing.

12 Plastic (Eames?) chair decorated with nude by artist Saul Steinberg, which was a sensation at opening of the Long Beach Art Center.

13 Alison Smithson sitting on the Trundling Turk.

GROPIUS
BRENDL
BREUER
SMITHSON
PROUVÉ
SCHINKEL
MIES VAN DER ROHE
RIETVELD
EL LISSITZKY
MONDRIAN
WEWERKA

14 Back of the invitation to the exhibition opening.

15 Alison and Peter Smithson with Stefan Wewerka at the opening of the Wewerka pavilion at Тест, Lauenförde, Germany. 1985.



10 Years of Stefan Wewerka in TECTA, 1975-1985 Wewerka Exhibition Pavilion

Alison and Peter Smithson

1985

Venue and dates: TECTA exhibition pavilion, TECTA furniture factory, Lauenförde, 7 September 1985.

Organizers: TECTA

Design: Stefan Wewerka / TECTA

Work team: -

Gross floor area: 145 m²

Itinerary: -

Exhibition catalogue: -

Related publications:

Alison and Peter Smithson, *The 1930s*

Additional information:

Opening lecture: Alison Smithson

Smithson exhibition:

Trundling Turk. Alison and Peter Smithson, 1953

His & Her Box. Alison and Peter Smithson, 1985

Reviews: -

This exhibition was a commemoration of Stefan Wewerka's partnership with ТЕСТА over a ten-year period (1975-1985), and also marked the opening of the Wewerka pavilion – one of their joint efforts. This lightweight, transparent exhibition pavilion built almost entirely of steel and glass gave the impression of having just landed on the meadow in the grounds of the ТЕСТА factory in Lauenförde.

The exhibits on show in the pavilion were tributes by ТЕСТА to acclaimed early-twentieth-century furniture designs by Gropius, Brendel, Breuer, Prouvé, Schinkel, Mies van der Rohe, Rietveld and El Lissitzky, in addition to designs by the Smithsons and Wewerka himself. Not just furniture was on show, however. The display included architecture, sculptures, fashion, films and books too.

The Smithsons' contributions to this exhibition were the 1953 Trundling Turk armchair and the first product of the partnership recently struck up with ТЕСТА, the His & Her Box – two small pieces of identical furniture apart from their colour (grey for His Box and red for Her Box) – for storing little keepsakes collected over the years.

The Little Box

The Little box gets her first teeth
And her little length
Little width little emptiness
And all the rest she has

The little box continues growing
The cupboard that she was inside
Is now inside her

And she grows bigger bigger bigger
Now the room is inside her
And the house and the city and the earth
And the world she was in before

The little box remembers her childhood
And by a great great longing
She becomes a little box again

Now in the little box
You have the whole world in miniature
You can easily put it in a pocket
Easily steal it easily lose it
Take care of the little box.¹¹

11 Poem by Vasko Popa published in *Charles Simic, Medici Groschengrab* (Carl Hanser Verlag, 1999) and reproduced alongside the axonometric projection of Her Box in Smithson and Unglaub, p. 15.

This furniture designed for collectors kept objects out of sight, helping them blend into an orderly, anonymous aesthetic. It was obviously related to earlier designs, such as the Red Boxes designed for the management of *The Economist* in the 1960s (and exhibited at the Cologne fair the previous year), and the Ronald Jenkins' Cabinet designed for the Jenkins' Room in 1952.

But at this point the focus of their furniture design shifted. The His and Her Box ended the era of boxes that conceal, and was succeeded by a new concept of boxes that display: the Jewel Box (Alison Smithson, 1988), the Cornell Boxes (Alison Smithson, 1988), and the Struwelpeter's Wallcabinet (Alison Smithson, 1986).

The Smithsons had always enjoyed compiling and collecting. Even as a young girl living with her grandmother in wartime Edinburgh, Alison was already collecting advertisements from American magazines such as *Ladies' Home Journal* and *Woman's Home Companion*.¹² A hobby and skill based on the 'select and arrange' that the Smithsons so admired in the Eameses, an approach offering new tools and a novel way of looking at ordinary life.

The Smithsons' collections were often food for thought too. In their 1956 article 'But Today We Collect Ads', they suggested that reading those magazine advertisements attentively could provide an insight into and an impulse for a new ordinary life.¹³ A collection of photographs covering such a wide range of subjects as biology, sport and art filled the halls of the Institute of Contemporary Arts during the 'Parallel of Life and Art' exhibition in 1953, and heralding in another 'great creative period' of modern architecture.¹⁴ It was also at that time, in 1985, that *The 1930's*, a book by Alison and Peter Smithson published by ТЕСТА and presented at the opening of the exhibition, was launched as the outcome of yet another collection.

During the years since the work was completed on the document called the Heroic Period of Modern Architecture we have kept a folder of papers called "The 'Thirties". In it were the treasures discovered by chance and the few sentences we had written that caught something of the nature of the work of the second generation.¹⁵

This book is also an indication of their great understanding with Axel Bruchhäuser based partly on their shared admiration for avant-garde masters for, as they said in the introduction:

Our sensibility towards the work of the period has been heightened over the last three or four years by working contact with the furniture manufacturer Axel Bruchhäuser of Lauenförde. [...] It is therefore as a product of a shared enthusiasm that this document of the 'thirties is published under the imprint of ТЕСТА.

A shared enthusiasm which would increase exponentially from this time onwards.

12 This era is described in detail in Beatriz Colomina, 'Friends of the Future: A Conversation with Peter Smithson', *October*, 2000.

13 Alison Smithson and Peter Smithson, 'But Today We Collect Ads', *Ark*, 18 (1956).

14 David Robbins, *The Independent Group: Postwar Britain and the Aesthetics of Plenty* (MIT Press, 1990), p. 129.

15 Alison Smithson and Peter Smithson, *The 1930's* (Berlin: Alexander Verlag, 1985), p. 3.

This exhibition showcased the first fruits of their partnership – *The 1930's* and *His & Her Box* – which also marked a shift in their relationship as Alison gradually replaced Wewerka as ТЕСТА's main advisor and designer.

The exhibition of furniture made by ТЕСТА; the presentation of the book about architecture in the 1930s; and the opening of a new exhibition pavilion. Three apparently unrelated events brought together in the exhibition sponsored by ТЕСТА: a set of artistic expressions that Alison interwove into her thought-provoking speech on the opening day of the pavilion. She recalled the furniture they had begun to design in the 1950s, with reference to two earlier texts – 'The Future of Furniture' (1958) and 'Concealment and Display' (1966) – in an attempt to draw attention to furniture's importance, then and now, in inhabitation.

Alison said that it was for this very reason that the book *The 1930's* showed how furniture had helped design our new mobility and casual aesthetics, and yet she felt that the pavilion designed by Wewerka was a reworking of the need for concealment and display making it possible to decorate by means of furniture mentioned in her writings. Finally, bringing the circle to a close, Alison also explained that ТЕСТА had furniture from the heroic period of modern architecture in the 1930s (shown in the book *The 1930's*), i.e. from the "concealment and display" period.¹⁶

16 Alison Smithson, Opening speech of the '10 Years of Stefan Wewerka in ТЕСТА, 1975-1985 exhibition' (Lauenförde, Germany, 1985).



16 Alison at the opening speech of the exhibition.

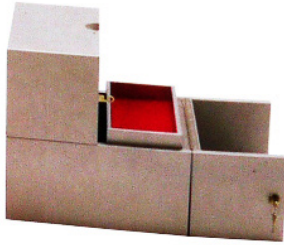

17 His & Her Box, Alison & Peter Smithson.
TESTA edition, 1985.

18 Opening the Her Box. Different stages.

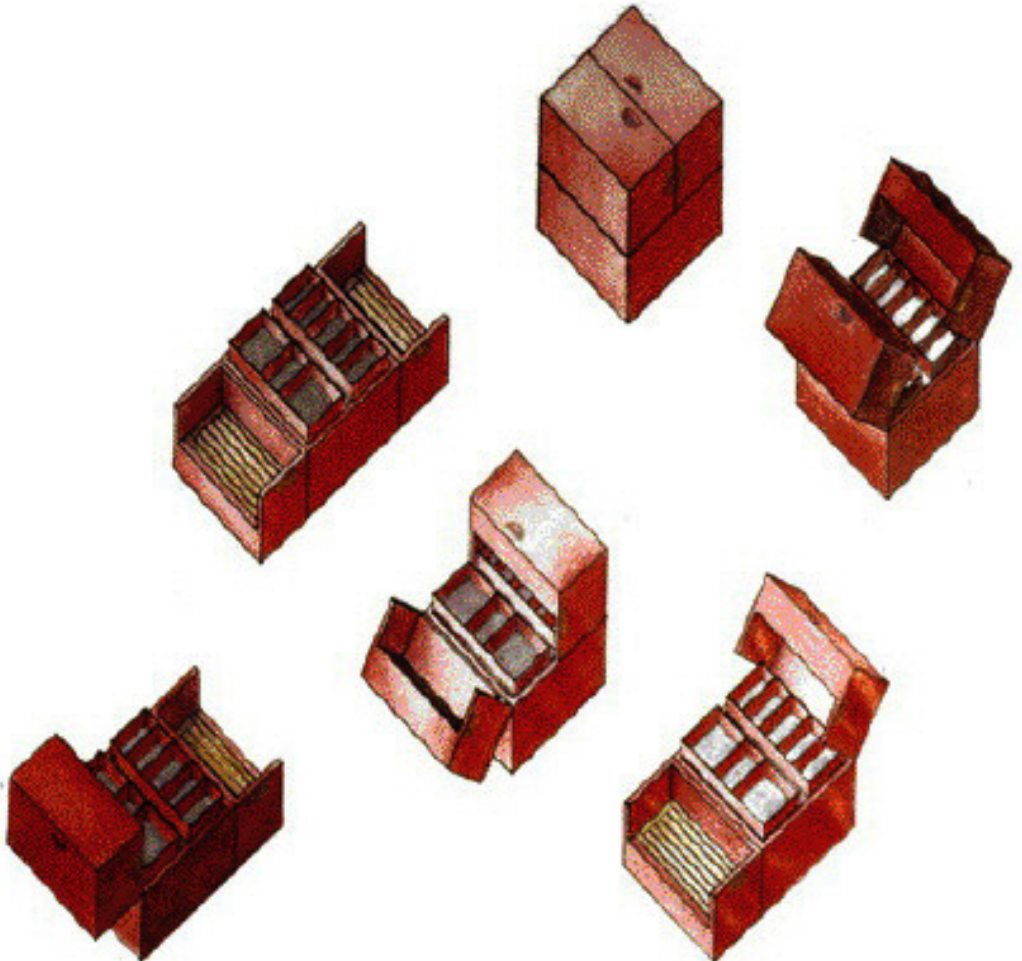

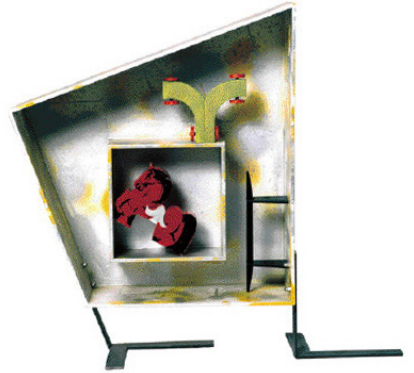
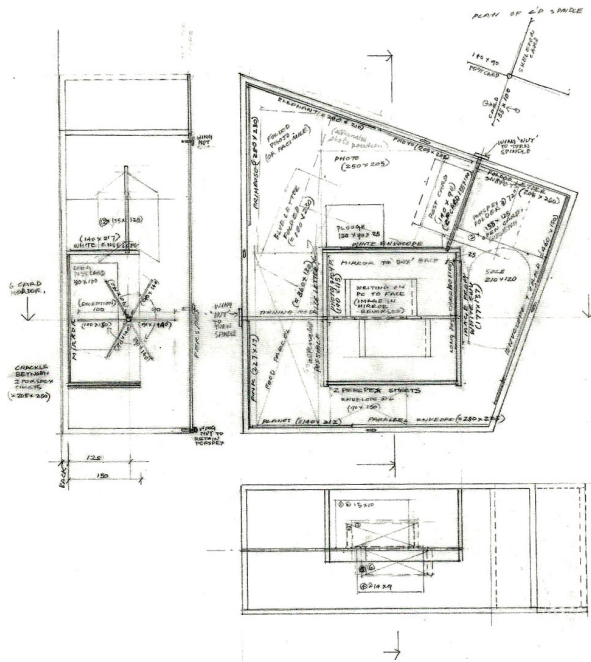

FILE FURNITURE I CORNELL BOXES

JOB NO.	ONE
DATE	1988
BY	ALISON SMITHSON
FOR	ALISON SMITHSON

Cornell Boxes, Alison Smithson, 1988

23 Prototype of the Cornell Box.

24 Working drawing.

25 Sketches for clusters of Cornell Boxes.

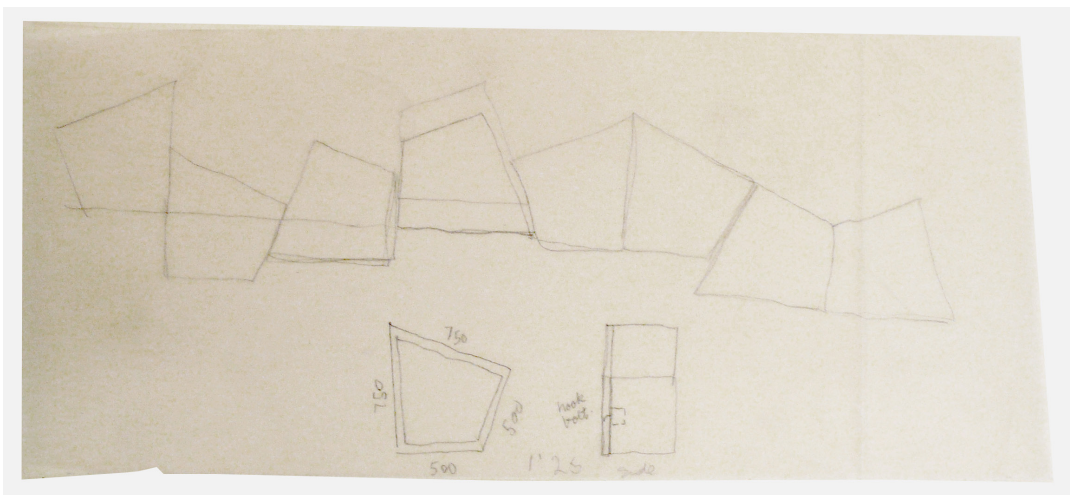

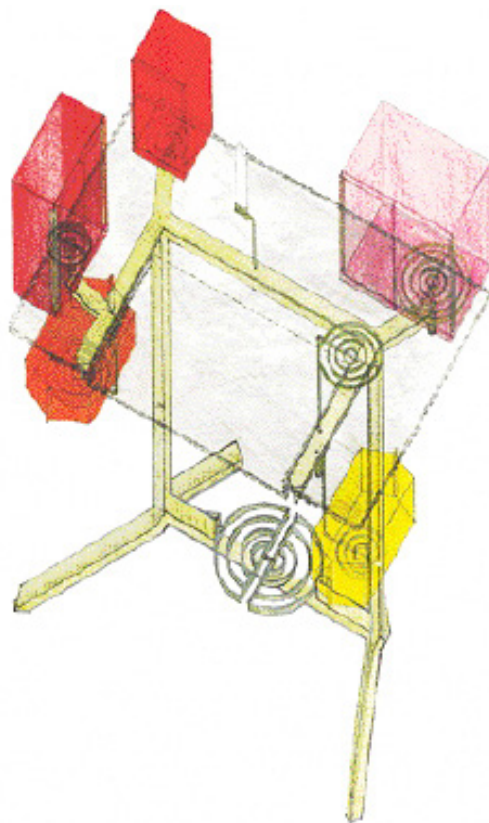
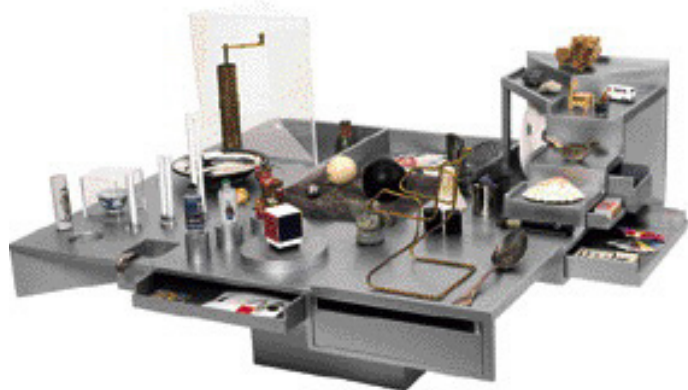

26 Collector's Table, Alison Smithson, TECTA version, 1983.

27 Waterlily/Fish Desk, Alison Smithson, TECTA version, 1986.

The Future of Furniture - Furniture of the 4th Generation Milan International Furniture Fair

Alison Smithson

1986

Event, venue and dates: Milan International Furniture Fair. Milan trade fair complex. 17-22 September 1986.

Organizers: TECTA

Design: Alison Smithson

Work team: -

Gross floor area: -

Itinerary: -

Exhibition catalogue: -

Related publications: -

Additional information:

Smithson exhibition:

Trundling Turk. Alison and Peter Smithson, 1953

Collector's Table. Alison Smithson, 1983

Waterlily/Fish Desk. Alison Smithson, 1986

Reviews: -

The 1986 Milan International Furniture Fair was the backdrop for the presentation of Alison Smithson's first designs for ТЕСТА: the Collector's Table and the Waterlily/Fish Desk.

The title of ТЕСТА's stand in Milan was indicative of a new mindset. ТЕСТА, well-known for its precise, handmade reproductions of avant-garde furniture, mainly Bauhaus-oriented, entered a new era focused on the future of furniture led by Alison Smithson – a new era characterised by experimentation.

'Both pieces of furniture represent a move from our generation's attitude to display and furniture in general.'¹⁷ As Alison said, the Collector's Table and the Waterlily/Fish Desk were the start of a new period in which both ТЕСТА and the Smithsons tried out 'devices and decorations' – resources which, in their words, characterised the architecture of the fourth generation of modernism.

A deliberate change of attitude occurred when the three generations of modernism originally identified by the Smithsons were followed by a fourth.¹⁸ The first mention of this fourth generation related to the 1980s appeared in the revised version of Peter Smithson's 1982 conference at Harvard (finally published in 1985 in *The 1930's*), which described its intention as being 'to signal the changes of use within the existing fabric'.¹⁹ Once a silent, receptive architecture able to take root in any given circumstances or place had been achieved, another step forward could be taken:

We can therefore think again of furniture as occupying positions in our spaces other than backed against the wall. Furniture of all functions – not only chairs or settees grouped for tables – can take position in space as collector's pieces; art works.²⁰

The first experiment with this new concept of architecture in the shape of furniture happened at the Milan International Furniture Fair of 1986 where the Collector's Table and the Waterlily/Fish Desk designed by Alison and Peter Smithson were exhibited together with the Lichtkoffer (light box) an experimental, electronic work of art by the artist Walter Giers²¹ designed to convey the changing sensations of a form of light 'that breathes' in the same way that 'sunlight comes and goes. Daylight changes. Clouds affect luminosity. [...] This highlights some spaces occasionally, alters shadows and animates objects, creating novel experiences.'²² A work of art in keeping with the architecture of 'devices and decorations' by this incipient fourth generation.

Collector's Table

This low, square table with a neutral, silver-grey finish is divided into nine sections that can be occupied in many different ways: drawers that conceal, shelves that display, pedestals that highlight, glass panels that protect, etc. The clear-cut geometry

17 Vidotto, *Alison + Peter Smithson. Obras y Proyectos*, p. 218.

18 Peter Smithson, 'Three Generations', *IL&UD Yearbook 1980*, 88–95.

19 Alison Smithson and Smithson, *The 1930's*, p. 13.

20 Smithson and Unglaub, p. 18.

21 'Lichtkoffer' (light box) Walter Giers, 1986.

22 Giers quoted (our translation) in *Die Zukunft der Möbel - Möbel der 4. Generation* (Lauenförde: ТЕСТА, 1986).

evident at first sight takes a back seat as the table opens up and becomes blurred when the table is inhabited by each user's own collection.

A table in terms of shape and size but designed like a display case for souvenirs, trinkets, antiques and belongings of all shapes and sizes. In the words of Dirk van den Heuvel, 'a celebration of collecting and, in a certain sense, a tribute to Charles and Ray Eames and their "select and arrange" technique'.²³ A showcase to exhibit one's personal interests, to deliberately and unreservedly display the art of inhabitation.

The finish on the Collector's Table is a move away from the basic colours of the Heroic Period of the Modern Movement that have been returned to repeatedly since the 1920's; basic colours that any collector might find not only difficult to integrate in his room but also find unreceptive to many objects he might want to display. The splatter-on-silver that TECTA offers, again brings the lacquered surface to happily co-habit with natural woods, marbles and so on.²⁴

23 Dirk van den Heuvel, 'Picking Up, Turning over and Putting With...', in *Alison and Peter Smithson - From the House of the Future to a House of Today*, 2004, pp. 12–28. (p.26).

24 Vidotto, *Alison + Peter Smithson. Obras y Proyectos*, p. 220.

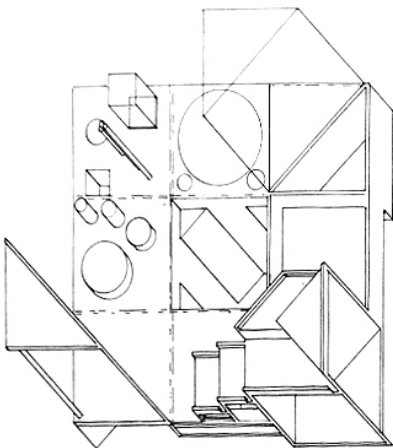

28 Axonometric drawing of the Collector's Table, Alison Smithson, TECTA version, 1983.

29 Living room of the Eames House, Charles and Ray Eames, 1949.

Waterlily/Fish Desk

Whilst the Collector's Table used the 'select and arrange' technique and could, therefore, be ascribed to the Eames Aesthetic, the Waterlily/Fish Desk belonged to the 'concealment and display' concept²⁵ mentioned in the Smithsons' article of 1966.²⁶ The desk features several red and orange plastic boxes ('a box for paper; a box for envelopes and cards; a box for the dictionary, Thesaurus, address book; drawers that by turning offer four front ends for pens, clips, etc.') representing water lilies and fish of different colours suspended above and beneath the surface of the water (the glass desktop).

Suspended water lilies and fish leaving the surface of the water clear, with just sheets of writing paper floating on the water, allowing the gaze and the mind to search for words in the depths of the water... In contrast with the colourful boxes, the desk consists of a sheet of neutral green glass suspended upon a delicate steel framework that constitutes 'an aid to thinking what to write, a base to pedal with both feet.'²⁷ A lightweight framework or enabling scaffolding which, like the Kiyomizu-dera temple in Kyoto, 'enters the air, captures adherent air space through the coloured transparency of its boxes which, at the touch of a finger, revolve in the air – to face the user – on their waterlily supports.'²⁸

An enabling frame for thinking that even constitutes 'an aid to thinking what to write'. A device Alison apparently designed for herself. As she explained in a short note:

.... fed by photographs I had been taking for a shared interest in waterlilies and goldfish, I remembered my life long impatience with writing desks. The free-standing thought liberated the programme for years.²⁹

Looking at the photograph of Alison poring over her papers and writing at her desk in the open air on the patio of the Upper Lawn pavilion, it is easy to imagine her pedalling, totally immersed in new associations of ideas and searching for words beneath the surface of the water in this device for thinking, and also to imagine Francisco de Goya lost in his dreams as Enric Miralles did:

Sitting there he almost seems to see our ideas... it is possible to fall asleep with your arms crossed... and to surprise ourselves with the vision of our shoes among the collected objects, or the fingers that are already fish...

It is a machine of transformations... it was a good exercise to develop them... And to begin to make montages that made these objects coexist with the world they come from... If we don't know it we can imagine it... And if not only try. It doesn't matter.³⁰

25 Van den Heuvel, 'Picking Up, Turning over and Putting With...' p.26.

26 Alison Smithson and Peter Smithson, 'Concealment and Display: Meditations on Braun', *Architectural Design*, July (1966), 362–63.

27 Vidotto, *Alison + Peter Smithson. Obras y Proyectos*, p. 218.

28 Alison Smithson, 'Into the Air', *MASS. Journal of the School of Architecture and Planning*, VII (1989), 7–10.

29 Van den Heuvel, 'Picking Up, Turning over and Putting With...' p.26.

30 Enric Miralles 'On the Trundling Turk' en Federico Soriano and Alberto Nicolau, 'Alison & Peter Smithson', *Arquitectura COAM*, 1992, 49–88. (p. 88).

30 Alison Smithson writing on the patio of the Upper Lawn pavilion. On her right, on the floor, Soraya Smithson asleep in her cradle. 1964.

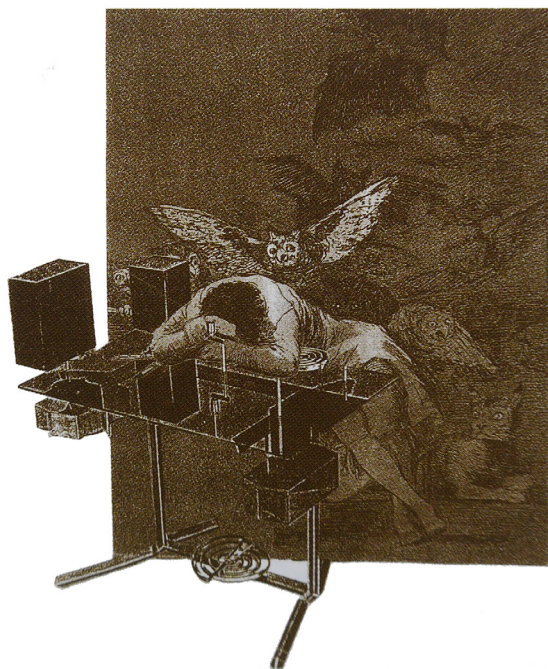

31 Photomontage by Enric Miralles in which the etching by Goya, *El sueño de la razón produce monstruos*, is superimposed on Alison Smithson's Waterlily/Fish Desk.

32 View from beneath the sheet of 'water' in the Waterlily/Fish Desk. TECTA version, 1986.



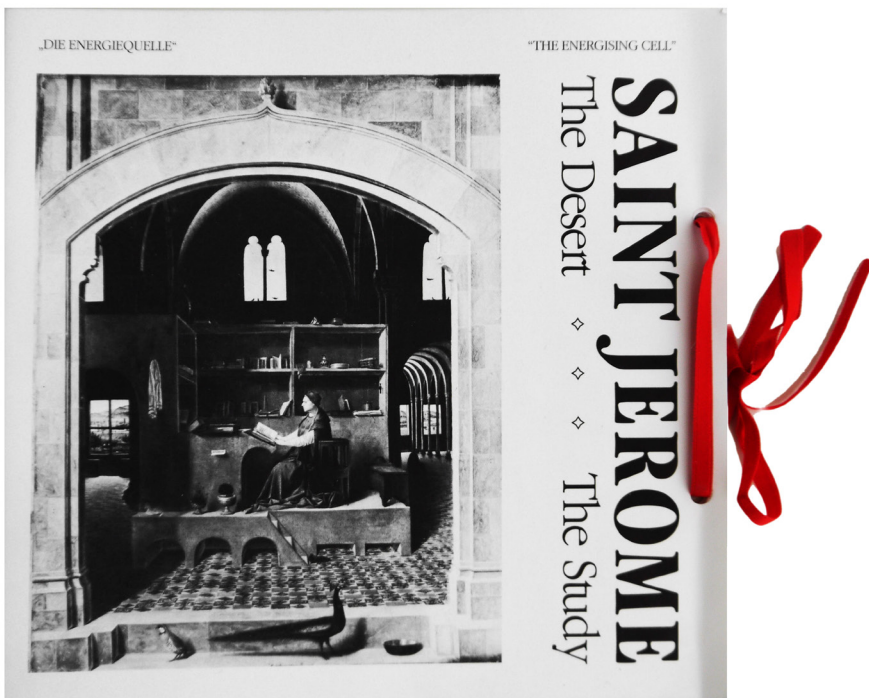
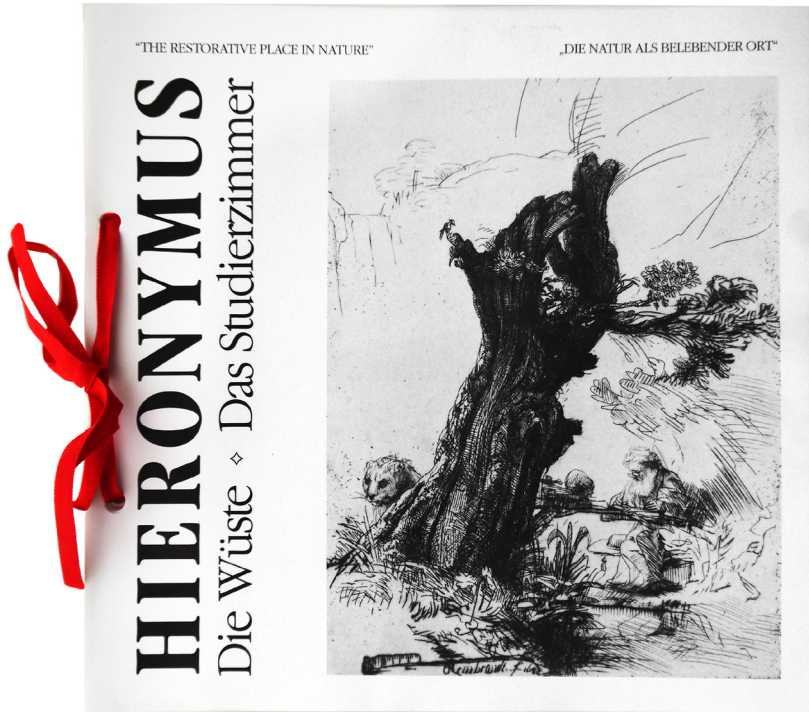

33 and 34 Front and back cover of Saint Jerome: The Desert, The Study. Alison Smithson and ТЕСТА, 1990.

Saint Jerome: The Desert – The Study Milan International Furniture Fair

Alison Smithson

1991

Event, venue and dates: Milan International Furniture Fair. Milan trade fair complex. 12-17 April 1991.

Organizers: TECTA

Design: Alison Smithson

Work team: -

Gross floor area: -

Itinerary: -

Exhibition catalogue: -

Related publications: Alison Smithson, *Hieronymus/Saint Jerome: The Desert, The Study* (Lauenförde: TECTA, 1990).

Additional information: -

Reviews: -

The Milan Furniture Fair was and still is the world's greatest showcase and the leading venue for the exhibition of the latest designs in furniture and home furnishings. It was against this backdrop that TECTA presented on its stand in 1991 and in conjunction with Alison Smithson, a new interpretation of the study of St Jerome and the publication of the essay *Hieronymus/Saint Jerome: The Desert, The Study*: a deliberate attempt to incorporate an element of criticism and discussion into the design festival of the furniture industry. This assertive stance is highlighted even more by the postscript on TECTA's invitation to the fair which reproduces the words spoken in 1973 by the architect and founder of the TECTA factory, Hans Könecke:³¹

None of this has to do with 'design'. A lot of nothing, of pomp and circumstances, little sense insufficient relation of human being [*sic*]. We should forget the word 'design'.

At the other end of the spectrum, far from any fashion or trend, St Jerome embodied the ideal balance of man and nature, 'the measure of human dwelling a thousand years before as well as nowadays and in the future'.³² With a view to recuperating this more human-oriented approach to inhabitation, TECTA built a new version of St Jerome's study on its stand at the 1991 fair based on 'Saint Jerome in his Study', the famous painting by Antonello da Messina: 'an allegory for the perfected functional space to serve inhabitation'.³³

The stand consisted of a simple study made entirely of untreated wood with an empty chair to remind viewers of the absent occupant. A study with no sign of inhabitation waiting to be appropriated by both its occupant and its location. A piece of furniture acting as an interface between inhabitant and context and facilitating their reconciliation.

The red chair indicates the occupant's absence but also stands out because it is the scene's only element with character and a contemporary feel. It is the Asymmetric Chair B1 designed by Stefan Wewerka for TECTA in 1979, a design representative of their work together. The following description of the chair is very eloquent: it mentions its function, the inherent possibilities of its form for creating new types of communication, relationships or spatial occupancy. In essence, it is an example of furniture at the service of its user or room, but which, as Könecke said, has nothing to do with design.

The B1 stands solidly on three legs, one part of the back acts as an armrest, and changing the seated position can actually be suggested by the shape pattern and material. This is no longer about sitting in rows; instead, it enables a range of conversations and activities. The detail in the

31 TECTA was founded in 1956 by the architect Hans Könecke. The company name comes from Latin, and roughly means "to design" or "to execute." In Axel Bruchhäuser and Christian Drescher, 'TECTA – Construction and Poetry' <<http://www.tecta.de/en/company/management/>> [accessed 27 April 2015].

32 Axel Bruchhäuser and Werner Bruchhäuser (1991) *Invitation to the Milan Furniture Fair in Milan 12.04 -17.04.1991*. Alison and Peter Smithson Archiv / TECTA Archiv Lauenförde.

33 Alison Smithson, *Hieronymus/Saint Jerome: The Desert, The Study*.

35 Antonello da Messina, *Saint Jerome in his Study* [Oil on lime]. National Gallery, London (c. 1475).

36 St Jerome's study erected on the $\pi\epsilon\sigma\tau\alpha$ stand at the 1991 Milan Furniture Fair.



finish, [...] developed as a stand-alone object working in a formal and functional harmony conducive to non-hierarchical communication.³⁴

At the TECTA stand (i.e. the new version of St Jerome's study), an essay by Alison Smithson entitled *Hieronymus/Saint Jerome: The Desert, The Study* was distributed. A small book with just over twenty pages but containing very profound concepts. A theoretical framework of great importance for the concept conveyed by a stand so far removed from the merely commercial considerations of the trade fair where it was on show.

Alison's essay looked like a small codex, a format which is in itself an allegory suggesting that the book could have come straight from St Jerome's desk. On the one hand in a direct reference to his era and Roman codices, it consists of several folded quires tied together with a ribbon;³⁵ and on the other, the colour of the ribbon which Alison suggested – cardinal red or, failing that, church purple – is a nod to the connection between St Jerome and the Christian world.³⁶

The text focuses on the habitats of St Jerome and in particular on the allegorical dimension stamped upon them by Renaissance paintings of 1400 to 1700, one thousand years after the saint's death.

Within their wider capabilities as subject matter, the depicted habitations share a quality of encapsulation and in this sense the images in Renaissance painting of Saint Jerome's habitats can also be thought of as allegories for the restorative place in nature and the energising cell supported by urban order.³⁷

Alison's text begins by examining two alternative idylls in the form of the saint's habitats: Saint Jerome in the desert, and Saint Jerome's study.

The desert represents the inhabitation of nature and its main characteristic is that man 'stands alone between the ground and the sky; [...] A place where a burned-in-clarity can be available to the mind; nature so immutable, omnipresent, that man is relieved of responsibility.'³⁸ A habitat which tallies with the period when St Jerome retired voluntarily into the desert of Antioch, a habitat depicted by many Renaissance artists including Lorenzo Monaco, Andrea Mantegna, Giovanni Bellini, etc., whose paintings also illustrate Alison's essay. She felt that the closest to this idyll in which 'Saint Jerome in the Desert expresses a human desire for the freedom that seems to

34 In Axel Bruchhäuser and Christian Drescher, 'Asymmetric Chair B1' <<http://www.tecta.de/en/produkt/b1/#21/ts/furniture/chairs/>> [accessed 27 April 2015].

35 From the Latin *codex*, originally *caudex* menaia 'trunk' for the earliest Roman documents were made of wax-coated, wooden boards tied together with cord. In the Middle Ages it became a book format consisting of quires which were folded, sewn and bound together.

36 St Jerome dedicated his entire life to studying the Holy Scriptures. Because of his learning and thorough knowledge of Latin and Greek, Pope Damascus commissioned him to translate the Bible into Latin.

37 Alison Smithson, *Hieronymus/Saint Jerome: The Desert, The Study*.

38 Ibid.

be in nature',³⁹ was Rembrandt's painting *Saint Jerome Beside a Pollard Willow* (1648), because this is the one chosen for the cover with the legend:

The Study is in nature; sheltered, quiet, refreshed and cooled by the stream... Surely the European's dream of Paradise.

At the other end of the spectrum, the study reflects the time when St Jerome lived in Rome. Renaissance paintings always depict him in an indoor setting – unlike in the desert scenes.

Jerome's Study can stand as an allegory for...

- the desire to enjoy built order
- the support by civilised services
- the shutting out of inclement weather, the ability to temper the climate
- a perfected sufficiency in the functional place of work, with the tools of profession, trade, housekeeping, to hand.

[...]

The Study as 'the machine for living in' was recognised in those writings of the Heroic Period of the Modern Movement in Architecture concerned with again raising the minimal *cell* to an art.⁴⁰

The images of St Jerome feature the timelessness of an ideal. Nature and the urban order have been and are always alternatives in which 'the one alternative exists within the other as if necessary, indivisible, reciprocal.'⁴¹ This is demonstrated by many portrayals of St Jerome's habitat: in the desert scene the city can be seen in the background, whilst nature can be seen through the window in the study.

Since the early 1950s, thanks to the mobility and freedom afforded by the car, many Europeans had travelled in search of a place in nature, somewhere revitalising, and had even been able to alternate between different types of inhabitation. Alison and Peter Smithson enjoyed doing this and did in fact regard this duality as an injection of positive energy into their lives and their work: on the one hand, everyday life in their city home in the South Kensington district of London; and on the other, weekends and holidays at Upper Lawn, their country house in the Wiltshire countryside. Even the journey between their two homes was stimulating too, as revealed by the book *AS in DS*,⁴² written like a logbook.

They were obliged to sell their countryside retreat in 1981, however, when the arrival of noisy neighbours prevented them from enjoying it. 'Noise, intrusion, remove from the pavilion in a tamed-nature, its power to re-generate through isolation by choice...for that choice no longer exists.'⁴³

39 Ibid.

40 Ibid.

41 Ibid.

42 Alison Smithson, *As in Ds: An Eye on the Road*, ed. by Christian Sumi (Delft University Press, 2001).

43 Alison Smithson and Peter Smithson, *Upper Lawn: Folly Solar Pavilion*, *Arquitectura i Urbanisme* (Universitat Politècnica de Catalunya, 1986).

This painful decision led them to ponder upon this pavilion and its land, resulting in 'A Fragment of An Enclave', a seminar at the ETSAB school of architecture in Barcelona in the 1985-86 year whilst the Smithsons were both visiting professors there.⁴⁴ In this seminar, said Enric Miralles in the introduction to the book *Upper Lawn: Folly Solar Pavilion*, Alison Smithson suggested that they 'think of our pavilion as a protected place: A Fragment of An Enclave... the piece of territory that can support and become the mid-1980's equivalent to the idyll of the "restorative place-in-nature"'. In other words, the seminar suggested that the audience think about the idyllic nature of St Jerome's habitat in the late twentieth century.

The booklet presented at the Milan Furniture Fair, *Hieronymus/Saint Jerome: The Desert, The Study* is based on one of the lectures that Alison Smithson gave in Barcelona as part of that seminar. This is why the last part of the document presented at the TECTA stand at the same fair, entitled 'Saint Jerome and the "Grotto"', examines this matter in depth.

Although this third habitat is rarely depicted in Renaissance paintings, St Jerome did live in a cave in Bethlehem at the end of his life. As Alison suggests, 'Jerome probably took to the cave as Study because of his knowledge gained in the Desert, that such a place offered effective protection in the Eastern Mediterranean climate [...] Thus the encapsulation of the Desert within the Study has already been accomplished.'⁴⁵

St Jerome's final dwelling is very revealing because it shows how the two ways of inhabiting the world – the desert and the study, or ascetic life in nature and functional life in the city – are perhaps not as radically different as Renaissance art would have us believe. The revitalizing role of nature together with the modern conveniences, peacefulness and solitude upon which study and creative activity thrive can arise anywhere providing that there is a sense of 'being cocooned' by a supportive framework outside: 'a piece of territory of one's own that society respects'.⁴⁶

Whether in nature, or in an urban setting, a place for creative activity will need to continue to rely on its fragment of space being within an enclave encapsulated within a protective territory.⁴⁷

Alison also pointed out that society began to be ecologically aware in the early 1990s and that the analysis of St Jerome's habitats was an allegory, 'a merging of the old reciprocity which will allow us to begin to think of a new form of restorative habitat for a future *light touch* inhabitation of the earth.'⁴⁸

44 'Territory of the Pavilion'. Extracts of a conference by Alison Smithson on 30 October 1984 and transcribed in Alison Smithson and Peter Smithson, *Cambiando El Arte de Habitar: Piezas de Mies, Sueños de Los Eames, Los Smithsons* (Barcelona: Ed. Gustavo Gili, 2001). p. 33.

Three Pavilions of the Twentieth Century: the Farnsworth, the Eames, Upper Lawn.' Conference by Alison Smithson in November 1985. Ibid. p. 141.

'Thoughts on Pavilions'. Unpublished text by Alison Smithson dated 6 and 7 June 1986. Ibid. p. 48.

45 Alison Smithson, *Hieronymus/Saint Jerome: The Desert, The Study*.

46 Alison Smithson and Peter Smithson, 'The Nature of Retreat', *Places*, 7 (1991), 8–23 (p. 19). The third part of this article 'The *Idyll* and St Jerome', was written when the 'Patio and Pavilion' installation was reconstructed. It compiles and sums up the ideas set forth in the document presented at the Milan Furniture Fair.

47 Alison Smithson, *Hieronymus/Saint Jerome: The Desert, The Study*.

48 Ibid.

At this point, the focus suggested by ТЕСТА at the Milan Furniture Fair, i.e. none of this has to do with 'design', deserves a second look.

The Saint Jerome reference is of crucial importance... [and] ... became the epitome of Alison Smithson's thoughts on inhabitation and her and Peter's notion of domesticity.⁴⁹

49 Dirk van den Heuvel, 'Alison and Peter Smithson: A Brutalist Story, Involving the House, the City and the Everyday (plus a Couple of Other Things)', 2013, p. 312.



37 *Saint Jerome in Bethlehem*, Kolnisch, 1440. [...] the distant city is surely intended to be Jerusalem and the chapel on the hill, Bethlehem: we might take this image as merging Desert and Study.'



1910 **GROPIUS** *Die moderne Architektur begleitet uns seit 40 Generationen: 1992 möchten wir den hervorragenden Beitrag, den die besten Architekten und Ingenieure hierzu geleistet haben, zeigen.*

1920 **RETVIG** *Modern Architecture has been with us for four generations: in 1992 we like to show the outstanding contribution of its furnishing mode by its most famous architects and engineers.*

1923 **BRECHNER** *Des plus jeunes générations au pas avec l'architecture moderne: en 1992 nous voudrions présenter, avec l'égard, l'excellente contribution des architectes et ingénieurs renommés.*

1924 **PRUVÉ** *International Möbelmesse Köln vom 21. bis 26. Januar 1992, Halle 2.2, Gang U7/V 6, Telefon Messestand TECTA 0221/886262*

1927 **MES VAN DER ROEPE** *Die moderne Architektur begleitet uns seit 40 Generationen: 1992 möchten wir den hervorragenden Beitrag, den die besten Architekten und Ingenieure hierzu geleistet haben, zeigen.*

1930 **LISSITZKY** *Modern Architecture has been with us for four generations: in 1992 we like to show the outstanding contribution of its furnishing mode by its most famous architects and engineers.*

1950 **RUGENBERG** *Die moderne Architektur begleitet uns seit 40 Generationen: 1992 möchten wir den hervorragenden Beitrag, den die besten Architekten und Ingenieure hierzu geleistet haben, zeigen.*

1953 **SMITHSON** *Modern Architecture has been with us for four generations: in 1992 we like to show the outstanding contribution of its furnishing mode by its most famous architects and engineers.*

1979 **WIERWKA** *Die moderne Architektur begleitet uns seit 40 Generationen: 1992 möchten wir den hervorragenden Beitrag, den die besten Architekten und Ingenieure hierzu geleistet haben, zeigen.*

1924/87 **PRUVÉ TECTA** *International Möbelmesse Köln vom 21. bis 26. Januar 1992, Halle 2.2, Gang U7/V 6, Telefon Messestand TECTA 0221/886262*

1981 **WIERWKA + TECTA** *Die moderne Architektur begleitet uns seit 40 Generationen: 1992 möchten wir den hervorragenden Beitrag, den die besten Architekten und Ingenieure hierzu geleistet haben, zeigen.*

1976/90 **TECTA** *Die moderne Architektur begleitet uns seit 40 Generationen: 1992 möchten wir den hervorragenden Beitrag, den die besten Architekten und Ingenieure hierzu geleistet haben, zeigen.*

1991 **SMITHSON** *Die moderne Architektur begleitet uns seit 40 Generationen: 1992 möchten wir den hervorragenden Beitrag, den die besten Architekten und Ingenieure hierzu geleistet haben, zeigen.*

38 and 39 Invitation to the TECTA stand at the International Furniture Fair of Cologne, 1992.

Modern Architecture Has Been with Us for Four Generations Cologne International Furniture Fair (imm Cologne)

Alison and Peter Smithson

1992

Event, venue and dates: imm Cologne. Kölnmesse (Cologne trade fair complex), Cologne. 21-26 January 1992.

Organizers: TECTA

Design: Alison and Peter Smithson

Work team: -

Gross floor area: -

Itinerary: -

Exhibition catalogue: -

Related publications: -

Additional information:

Smithson exhibition:

Trundling Turk I. Alison and Peter Smithson, 1953 (TECTA version, 1984)

Trundling Turk II. Alison and Peter Smithson, 1976 (TECTA version, 1991)

Reviews: -

A single sentence, a veritable statement of intent, appears on the back of the invitation to the 1992 Cologne Furniture Fair: 'Modern Architecture has been with us for four generations; in 1992 we like to show the outstanding contribution to its furnishing made by its most famous architects and engineers.' Alison and Peter Smithson's proposal for the 1992 fair was a tribute to the modern architecture and furniture designed by architects in the twentieth century, and they included themselves as leading lights.

1910 Gropius
1920 Rietveld
1923 Breuer
1924 Prouvé
1927 Mies van der Rohe
1930 El Lissitzky
1950 Ruegenberg
1953 A+P Smithson
1979 Wewerka
1924-87 Prouvé+TECTA
1981 Wewerka+TECTA
1976-90 TECTA
1991 A+P Smithson

The Smithsons appeared twice in this trend: in 1953 with the Trundling Turk, and in 1991 with the prototype of the Trundling Turk 2 (also known as the San Diego Chair). The Trundling Turk began to be manufactured in 1983 and was launched at the International Furniture Fair of Cologne in 1984, a time when the Smithsons were already working with TECTA on the manufacture of the Trundling Turk 2 based on their late-1970s prototype.

In 1976, when they had not yet materialised the original design of the Trundling Turk from the 1950s, they entered a new version of the previous model for the San Diego Chair Competition. In the new version, also mounted on wheels, the simple original design was stripped down into layers that separated the structure from the upholstery, and the frame from the content. This is a clear reflection of how the Smithsons shifted their approach to architecture and way of thinking to their furniture design which regarded the armchair as a framework waiting to be appropriated by the user. The armchair was designed at a time when the pair were experimenting with lattices and frameworks. Following the success of the timber frames at St. Hilda's College, they were working on the Lucas Headquarters, the Yellow House, the Millbank Apartments and, of course, the line of thought embodied in the 'A Line of Trees... A Steel Structure' exhibition.

In 1982, Alison and Peter Smithson admitted that 'continuing the theme of furniture as the vehicle of life-style, the San Diego Chair, 1976, was the soft-cornered remembrance of the hard-edged Trundling Turk,' hence the perforated, bent plywood structure with rounded corners upholstered in a slightly velvety, Arab-style fabric.

This was an armchair designed for public places and intended to encourage leisurely, informal conversation whilst permitting ‘mobility – like that of a Persian carpet, without the stiff formality of a club armchair or the stern, unchanging status of a sofa.’⁵⁰

In 1984, when the Smithsons began to discuss manufacturing the San Diego chair with ТЕСТА, they retained the wooden frame but changed the upholstery. At this point Alison suggested the Bermuda 2067-171 fabric produced by the famous German textile manufacturer JAB, but production did not start until 1994.

The International Furniture Fair of Cologne in 1992 was the showcase for just one prototype of the Trundling Turk 2 along with other new designs by Alison such as the Lantern (a lamp which was a great success at the ‘Tischleindeckdich a.s.o.’ exhibition); the Starfish Mirror (fig. 43); and the Ikat fabric.⁵¹

50 Vidotto, *A + P Smithson : pensieri, progetti e frammenti fino al 1990*. p. 53. Our translation.

51 ‘The term ‘ikat’ comes from the Malay word ‘mengikat’, meaning to tie or to bind. This refers to the tie-dyeing method used to give these textiles their uniquely vibrant colour and design. Ikat has now come to refer to the textiles themselves as well as the process.’ (Victoria and Albert Museum, ‘Making Ikat Cloth’ <<http://www.vam.ac.uk/content/articles/m/album-with-nested-carousel18/>> [accessed 11 March 2015]). ‘This ancient way of making fabric involves a resist dyeing process in which the fibres are tied to prevent the dye penetrating certain areas. They are then dyed and, as the fabric is woven, the design appears according to where the fibres were bound and the colours used. As a result, the design is identical on both sides of the fabric.’ (Teixits Riera, ‘¿Qué es el Ikat?’ <<http://teixitsriera.com/telas-mallorquinas/el-ikat-en-mallorca/>> [accessed 11 March 2015]). Our translation.

The documents consulted in the Alison and Peter Smithson Archive suggest that Alison worked on fabric design from at least 1985 onwards. One of the folders in the archive contains many sketches of designs for a dhurrie rug using this dye technique in 1988 (fig. 44-46).

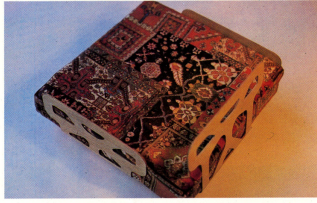
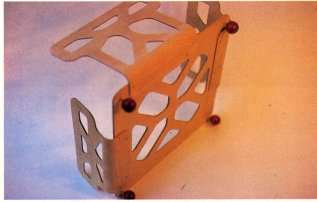
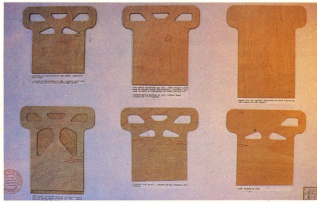

40 and 41 Trundling Turk II with Alison, Soraya and Snuff Smithson (Photo: Peter Smithson) April 1984.

42 San Diego Chair, 1976. The box and pieces of the frame before assembly. The upholstery laid out round the frame and then placed in position.

43 Photographs of the TECTA stand at the Cologne International Furniture Fair (1992).

44-46 Set of drawings. Alison's designs for the dhurri rug (1988).



Köln 1992 IKAT-Messe

Neue Modelle:

IKAT-Sofa	F 44/3
Breiter Sessel	F 44/2
Sperrholz-Schrank	S 70
Roll-Kommode	K 42
"Angel"-table	M 31
"Starfish Mirror"	S 36
Laterne	L 30
Miniatur	MB 42

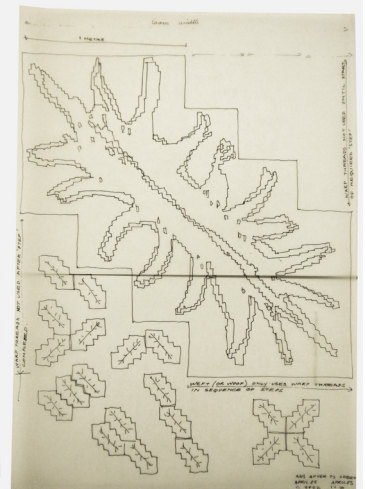
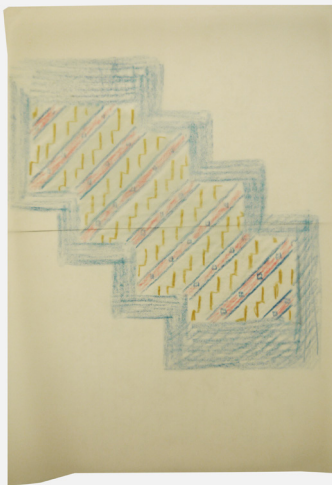
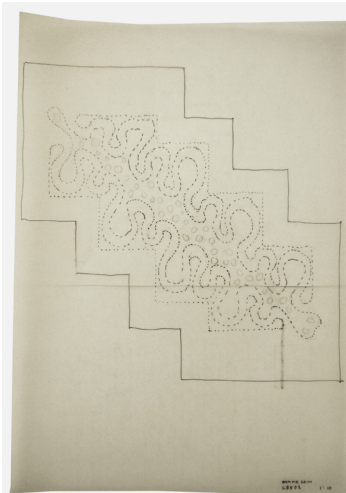



47 Poster of the 'Tischleindeckdich a.s.o.' exhibition, Alison Smithson, 1992.

TischleinDeckDich a.s.o.

Alison Smithson

1992-1993

Venue and dates: Janine Mautsch Gallery, Cologne. January 16-31, 1993.
Aedes Gallery, Berlin. February 15-March 15, 1993.

Organizers: TECTA

Design: Alison Smithson

Work team: -

Gross floor area: 100 sqm + terrace (Mautsch gallery, Cologne); 165 sqm (Aedes gallery, Berlin)

Itinerary: -

Exhibition catalogue: Alison Smithson, 'Tischleindeckdich'

Related publications: -

Additional information:

Exhibited together with the Hexenhaus photo exhibition at the Mautsch gallery
Opening speech at the Mautsch gallery: 'Anticipatory Space' by Peter Smithson
Opening speech at the Aedes gallery: 'Tischleindeckdich at Galerie Aedes' by Peter Smithson

Reviews:

'Tischleindeckdich', *Kölner Stadt-Anzeiger* (Cologne, 15 January 1993).

'Verzaubert: "Tischleindeckdich" in Der Galerie Mautsch', *Kölner Stadt-Anzeiger* (Cologne, 26 January 1993).

Holger Schnitgerhans, 'Tischlein Deck Dich Usw...', *Architektur & Wohnen*, 1993, offprint.

The eye-catching title of the exhibition, *Tischleindeckdich*, is the name of the electrical table, the centrepiece of the exhibition also designed by Alison Smithson for TECTA. The table's design and strange name which could be translated as 'little table, set yourself!', were inspired by the Brothers Grimms' fairy tale whose original title in German is '*Tischlein deck dich, Goldesel und Knüppel aus dem Sack*'⁵². In this tale, the table is the gift from a joiner to his apprentice, one of the sons of the tale's main character, a tailor, as a reward for working so well.

A little table which had no particular appearance, and was made of common wood, but it had one good property; if anyone set it out, and said, 'Little table, spread thyself', the good little table was at once covered with a clean little cloth, and a plate was there, and a knife and fork beside it, and dishes with boiled meats and roasted meats, as many as there was room for, and a great glass of red wine shone so that it made the heart glad.⁵³

Alison and Peter Smithson had been working with TECTA for a long time on designing the table and preparing the new exhibition for its joint showing, not in a strictly trade context like the furniture fairs they had taken part in previously but in an artistic setting. The Smithsons now had the chance to take part in the architectonic debate, and so, after more than a decade not involved in that scene, they could not afford to make any mistakes. So, together with Axel Bruchhäuser, they decided to exhibit TECTA furniture at two German art galleries: the Mautsch gallery in Cologne and the Aedes gallery in Berlin.

The first exhibition took place in Cologne, in January 1993, in parallel with TECTA's usual participation in the International Furniture Fair held in January each year. The gallery chosen by Axel Bruchhäuser was the Mautsch gallery because, as he said in a letter to Alison, 'Mrs Mautsch is leading this gallery since ten years and has good connections to the art scene and good architects'.⁵⁴

The second exhibition was in Berlin, in February, at the famous Aedes gallery forum.⁵⁵ It was already more than ten years since Alison and Peter Smithson's first and only showing at the Aedes gallery in 1980 in its inauguration group exhibition, 'In memoriam Kongresshalle', where they were invited to share their thoughts in an ideas exhibition to celebrate the self-destruction of the Kongresshalle and, shortly afterwards in the same year of 1980, where they held an individual exhibition of the project they had entered for the Hauptstadt Berlin competition of 1957.

52 Translated into English as 'The Wishing-Table, the Gold-Ass and the Cudgel in the Sack'.

53 Jacob Grimm and Wilhelm Grimm, *The Complete Grimm's Fairy Tales*, Knickerbocker Classics (MBI Publishing Company, 2013), p. 130.

54 Axel Bruchhäuser (1992, July 7). [Letter to Alison Smithson]. Alison and Peter Smithson Archiv / TECTA Archiv Lauenförde.

55 This gallery founded in 1980 was the first architecture gallery in Europe. Since then it has been the venue for many acclaimed exhibitions, symposia, lectures and discussions always with a view to fostering debate and making the culture of architecture more accessible to the general public.

‘Tischleindeckdich a.s.o.’ is, therefore, a very well thought out exhibition because it also aimed to echo and showcase an approach initiated a long time before, in the early 1980s to be precise, when they started working with ТЕСТА and designing furniture again. As Peter Smithson also said in the catalogue: ‘For some ten years Alison Smithson has been working with him [Axel Bruchhäuser] to get the feeling of the furniture that will support the “style” – the aesthetic, the life intentions – of the next period.’⁵⁶

The exhibition aimed to convey to the general public the findings of this joint research into this aesthetic, these life intentions of the next period, and this led to the reason for the expression ‘a.s.o.’ (‘and so on’) in the title of the exhibition: to indicate a new start, a new period that is about to begin, albeit always as a continuation of modernism. The exhibition showcases the Tischleindeckdich table as an example of the furniture in keeping with this new underlying awareness, but also prompts the spectator to think about this ‘and so on’ which not only includes the other elements in the accompanying heroic period but also indicates that this is merely a starting point, a first step towards this new awareness.

This was not the first time that Alison Smithson used ‘a.s.o.’ with the same evocative intent. Almost thirty years earlier, in 1966, Alison finished her unpublished manuscript *1916 A.S.O.* which describes in her own words ‘the period in Germany in which the modern movement in the arts took root’.⁵⁷ The Smithsons also refer to that piece as a ‘sensitivity primer’ of the ‘earth of the Modern Movement’ or the period of the ‘mythical beginning’. In this instance, ‘a.s.o.’ also emphasised that same idea of the continuity of a single process, thereby highlighting that the intention of the manuscript was not only to conjure up the feelings of that precise period of time but also to show that said period was the start of an era. In this respect, *1916 A.S.O.* was the start of modernism.

Hence, just as the sensibilities portrayed in the novel, in the German lifestyle of 1916, were, according to Alison Smithson, the start of a new dawn in art and architecture, so was the Tischleindeckdich of the early 1990s a recognition of the feelings of that period which were to prove essential for the ‘style’ of the next era in the immediate future.

56 Alison Smithson, *Tischleindeckdich (exhibition catalogue)*, 1993.

57 Alison Smithson, ‘1916 A.S.O.’ (Unpublished MS, 270 pages). Harvard University, Graduate School of Design, Frances Loeb Library, Special Collections, The Alison and Peter Smithson Archive: An Inventory.

Alison sent this manuscript to Axel Bruchhäuser in 1986 in the form of a diary with the intention of having it published but this never happened. Some excerpts are published in Alison Smithson, ‘My Kind of Town’, *Architecture Today*, May (1990), 88; Alison Smithson, ‘Sulla Trama Del Movimento Moderno’, *Spazio e Società*, n. 20 (1982), 74–83.

The manuscript begins in the late summer of 1915 at a time when Germany was in the throes of World War I. According to Dirk van den Heuvel in his PhD dissertation, this suggests that ‘Alison Smithson attempted to connect those wartime experiences to the specific sensibilities of the historic avant-garde and the architects of the Heroic Period’ (van den Heuvel, p. 199). In addition, this idea is even more compelling bearing in mind that in the introduction to *The Heroic Period of Modern Architecture*, the Smithsons say that ‘In the period just before and just after the first world war a new idea of architecture came into being’. The two documents are, furthermore, from the same period: *1916 A.S.O.* dates from 1966, and *The Heroic Period of Modern Architecture* was first published in 1965 (Alison Smithson and Peter Smithson, ‘The Heroic Period of Modern Architecture’, *Architectural Design*, December, 1965).

There is no doubt that the Tischleindeckdich was not meant to be simply a piece of furniture but mainly a device to trigger the imagination and, in this respect, it is also very close to spirit of the Grimms' fairy tales. It must be remembered, as one of the captions in the Cologne exhibition says, that 'we are in the Wesser highlands, the region where the brothers Grimm once wrote their fairy tales. This region not only produces fine woodwork but also predicts the future on the basis of the past.'⁵⁸

The design of the table is very simple. A cube measuring 50 centimetres along each side that unfolds in a matter of seconds after pressing a button on a remote control (as in the fairy tale by the brothers Grimm after giving the command: 'Tischlein, deck dich!') to form a circular table 150 centimetres in diameter already set with a banquet. A simple, curious and yet poetic spectacle. An almost a magical performance which Peter Smithson remarked upon too: 'From closed cube to open table: so simple; such a beautiful idea. From this innocent transformation the Tischleindeckdich of this exhibition have sprung.'⁵⁹ A fairy tale come true.

To make this fairy-tale fantasy come true, Alison Smithson had been working with ТЕСТА on the design of this table for more than two years because 'very ingenious workmanship was needed to build the pieces that unfold like petals.'⁶⁰ In the process, two prototypes were made with two different bases. The first one had four feet and the second, four curved plates with a hole, and a different colour range.⁶¹ Even the fruit for the banquet was carefully chosen too.⁶²

In addition to the extreme simplicity of the table's design and pursuing the metaphor of the fairy tale, another eye-catching aspect are the 'plates' awaiting the hypothetical diners. Eight equally spaced plates, one on each of the table's leaves. The plates are, in fact, circular, glass-filled holes which, besides recalling said metaphor, also endow the table with great lightness once opened out.⁶³

In her opening speech, Alison pointed out that 'the TDD [Tischleindeckdich] is a little hard, even brutal...in a way, my butcher's block idea touched this character'⁶⁴ but after a few seconds its appearance changes radically into a table that looks far more fragile than it actually is.

58 Schnitgerhans. Our translation.

59 Alison Smithson, *Tischleindeckdich (exhibition catalogue)*.

60 Schnitgerhans. Our translation.

61 The prototypes are still all housed at the Kragstuhlmuseum in Lauenförde.

62 So much so that Alison chose each item and sent them by post to Axel Bruchhäuser with a detailed description and instructions about how to set them on the table. Smithson, Alison (1991, June 23). [Letter to Axel Bruchhäuser]. Alison and Peter Smithson Archiv / ТЕСТА Archiv Lauenförde.

63 The idea of the holes, according to Axel Bruchhäuser, stemmed from the panels with holes in the Prouve house which were tried out for the first time, as per Alison's idea, in ТЕСТА's M21 tabel (1990). Bruchhäuser, Axel (2015, March 31). [email to the author].

64 Alison Smithson (1992, August 6). [Letter to Axel Bruchhäuser]. Alison and Peter Smithson Archiv / ТЕСТА Archiv Lauenförde.

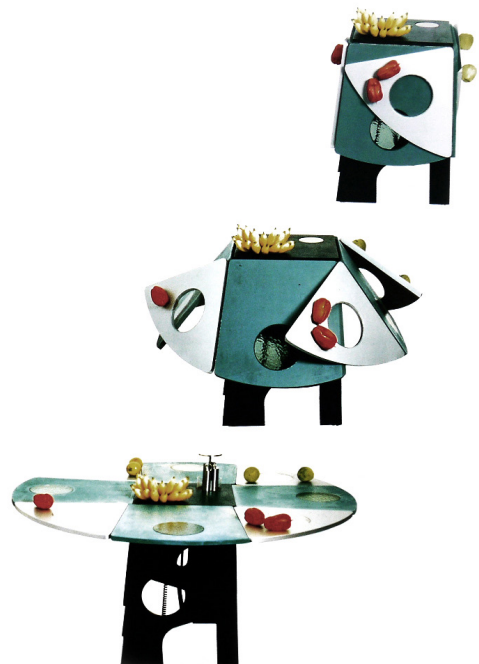

48 Front of the book by Jacob and Wilhelm Grimm, *Tischlein Deck Dich* (with colour pictures by Fritz Kredel) (Potsdam: Struwelpeter-Original-Verlag, 1991).

49 Three stages in the Tischleindeckdich opening. Alison Smithson and ТЕСТА, 1992.

50 Tischleindeckdich. Poetic vision of the table in a winter landscape.

For transformation is a theatrical word...we remember from childhood the wonder of the transformation scene where Cinderella is made ready for the ball...made ready for a new life.⁶⁵

The magical transformation embodied in the movement of the Tischleindeckdich permeates the whole exhibition including the graphic design of the poster, the invitation and the catalogue.

The poster portrays different moments of the table in motion in five partly overlapping images in a diagonal composition offset by the blackletter typeface used for the name of the table and the title of the exhibition: Tischleindeckdich. The typeface originally chosen by Alison 'to carry through the "fairy story" of the TDD, which is nineteenth century romantic gothic' was the German-flavoured Fette Fraktur.⁶⁶

The invitation was the first item Alison designed for this exhibition and, in a way, it too embodied the movement and nature of the Tischleindeckdich table – the curve and hole to be precise, which were also the basis for the design of the exhibition catalogue. In the end, the catalogue and the invitation were combined in a single folder because of the difficulties of using the materials chosen for the catalogue (transparent paper and embossed text) for the invitation too.⁶⁷

In order to disassociate herself on this occasion from trade fairs and establish the exhibition even more in the artistic sphere of art galleries, Alison suggested to Axel that the catalogue design should 'use the Aedes Gallery catalogue size rather than your [TECTA's] catalogue size. Basically because this is not a furniture show and it would be useful for TECTA to be in another series.'⁶⁸

After applying the curve and hole concept to the Aedes format (17 x 18.5 cm), the exhibition catalogue unfolded like the petals of the Tischleindeckdich. At first sight it is an opaque, compact and almost square pamphlet which changes and becomes lighter as it opens up until the behind-the-scene magic of the exhibition appears beneath the final fold. Once completely open, the pamphlet resembles the table seen from underneath whilst its texts and illustrations reveal the mechanism making its portrayal possible.

Both aspects are also dissociated in the physical design of the catalogue. The cover is made of a heavy, gloss paper printed in a metallised green colour featuring just the

65 Alison Smithson and Peter Smithson, *The Charged Void: Architecture* (New York: Monacelli Press, 2001). p.592

66 Alison Smithson (1992, August 25). [Letter to Axel Bruchhäuser]. Alison and Peter Smithson Archiv / TECTA Archiv Lauenförde.

Fette Fraktur is a nineteenth century typeface developed more for advertisements than text. It belongs to the family of the original Fraktur script used for almost one hundred years as a standard text face in German-speaking Europe. It was used at that moment for advertising and packaging to give a sense of a traditional Austrian, Bavarian or German flavour.

In the end, this typeface could not be used due to printing problems because Alison wanted a single typeface for all titles and texts including the embossed texts so a more conventional blackletter was chosen. However, the poster shown in *The Charged Void* does feature the original typeface, an indication of her fondness for her first choice. See Alison Smithson and Peter Smithson, *The Charged Void: Architecture*, p. 592.

67 Smithson, Alison (1992, September 23). [Letter to Axel Bruchhäuser]. Alison and Peter Smithson Archives. TECTA Archive, Lauenförde.

68 Alison Smithson (1992, August 25). [Letter to Axel Bruchhäuser].

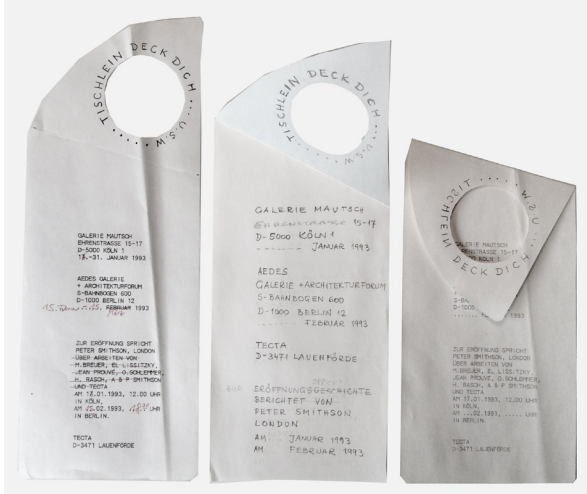

51 First ideas for the 'in movement' invitation which Alison Smithson made by hand.

52 Printing proofs for the poster. Photographs taken outside Axel Bruchhäußer's office at the TECTA factory. (Photo: Axel Bruchhäußer).



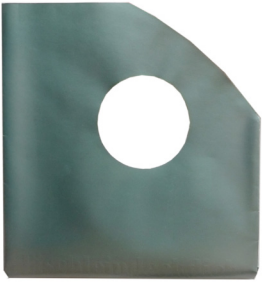

53-56 Catalogue of both exhibitions. Folded and unfolded.



discreetly embossed title of the exhibition. The sheet inside, a lightweight film with full details printed on it, is glimpsed at first through the holes but can only really be seen when the last fold is opened up.

The table is the star of the exhibition and all the associated graphic design, but what brings the entire exhibition display together and creates its atmosphere is the 'fairy colour', i.e. Schneidersohn 250/75 metallic green, also used for the advertising materials associated with the exhibition. The poster is metallic green, the catalogue cover is metallic green and the texts inside are printed in dark green in anticipation of the greenness of the exhibition because all the exhibits on show were metallic green: 'These have all to be "magic'd" to be brought into the fairy theme/ring.'⁶⁹

The pieces of furniture that Axel Bruchhäuser and Alison Smithson chose to be displayed may be divided into two groups: those from the period that the Smithsons called 'the 'thirties'⁷⁰, i.e. items mainly by Mies van der Rohe, Marcel Breuer and Jean Prouvé, and 'which Axel Bruchhäuser sought out and reproduced from originals or fragment of originals, or made from original drawings and patent documents'; and those which they designed for themselves and for ТЕСТА, such as the mechanical Tischleindeckdich. In other words, the items on show were 'the familiar old pieces' and 'the new' but all of them were equally painted in the same dullish metallic green – 'that is already the colour of the Waterlily and Fish Desk base'⁷¹ – except for the two multicolour Tischleindeckdich tables.

Work focused first on the character of each item before being displayed because despite all being dressed in the same metallic green, they changed in different ways.

The Marcel Breuer pieces, painted complete in dull metallic green without the glitter of nickel or chrome, are rather like rattan. They remind me one of the real bicycles of the 1920s [...] the mythical beginning of tubular steel furniture.

The Trundling Turk, in soft green silk with a dull metallic green chassis, changes from a student knockabout piece to something luxurious.

The Collector's Table, a dull silver in the original, changes little spatially by being metallic green. [...]

And so on.⁷²

This exhibition dramatised the transformation of individual items of furniture and also those grouped into an ensemble that could act spatially together in a new way, staging the future of furniture. In the catalogue, Peter Smithson explains the reason for the 'green-ness ambience'.

As she has projected it, the colours of the furniture would be softer – metallic green, aubergine; the forms pleasant to brush against, being capable of living one piece with the next and of building-up into an ensemble: all to be lightweight toward the increasingly put-away, leisurely

69 Ibid.

70 See the exhibition '10 Years of Stefan Wewerka in ТЕСТА, 1975-1985' in this chapter and the book *The 1930's*.

71 Alison Smithson (1992, August 25). [Letter to Axel Bruchhäuser].

72 Peter Smithson, 'Opening Lecture of the Tischleindeckdich Exhibition at the Mautsch gallerie' (Cologne, Germany, 1993).

indoor-outdoor mode of the next century.

In the exhibition this “ensemble” quality is carried as an idea by the bonding together which is consequent of the all-over ethereal green colour of all the furniture pieces. Only the Tischleindeckdich have many colours.⁷³

Many years before, Alison and Peter Smithson had seen how stage resources and evocative properties could be used to make individuality merge into the whole in plays by Berthold Brecht and the Berliner Ensemble in the 1950s, as Peter explained in the opening lecture at Aedes: “Those who went to performances of this company in the 1950’s and who did not speak German were very conscious of what they saw on stage. In my memory everything... stage, costumes, make-up, objects-on-stage, scenery... everything was touched with white, so as to unify stage and action into a visual ensemble.”⁷⁴

The Mautsch gallery and the Aedes gallery were completely different exhibition venues. The four exhibition rooms at the Mautsch gallery were like living rooms, indeed the halls were on the first floor of a high-rise building alongside an outdoor balcony also forming part of the exhibition in the centre of Cologne. The gallery in Berlin, however, was a wide-open space leading on to a pedestrian precinct underneath a railway. As a result, both exhibitions were quite different despite featuring the same items. But rather than being a problem, this was an advantage because it increased their ability to convey their idea that the show did not have a hard and fast format but adapted to each venue.

This show is more like a travelling theatre, where in each town there is a different place of performance, which means the play has to be ‘adjusted’, ‘re-written’, ‘re-cast’ to suit the nature of the place... to get the essential meaning over.⁷⁵

In Cologne the pieces of furniture were set out in different rooms, always giving the Tischleindeckdich tables pride of place and avoiding any impression of furnishing a room. Alison made this quite clear: ‘We are not after a room in L’Esprit Nouveau manner’.⁷⁶ Visitors to the first hall were met by the Reclining Chair on Wheels (1928-1930) hanging from the ceiling and the Folding Chair (1927), both by Marcel Breuer, and also the Table Aeronautique (1924) by Prouvé. The focal point of the second hall was the Schlemmer Cabinet (1941), whilst in the third room, in the middle of the room itself and the path through the exhibition, stood the two Tischleindeckdich tables in motion, with the Collector’s Table and the Waterlily and Fish Desk in the background.

Before the opening of the exhibition, Alison travelled to Cologne to put the finishing touches to the lighting and arrangement of the exhibits in an attempt to

73 Alison Smithson, *Tischleindeckdich (exhibition catalogue)*.

74 Peter Smithson, “‘Tischleindeckdich’ at Galerie Aedes’ (Berlin, Germany, 1993).

75 Ibid.

76 Alison Smithson (1993, January 20). [Letter to Axel Bruchhäuser]. Alison and Peter Smithson Archives. ТЕСТА Archive, Lauenförde.

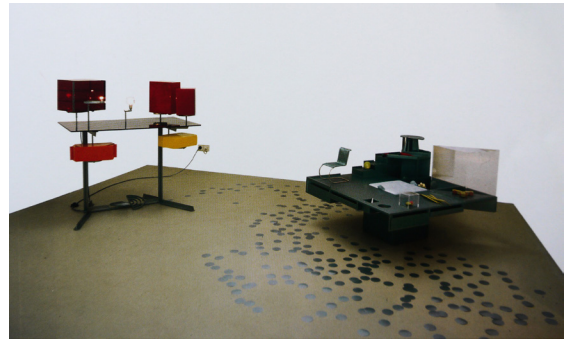

57 and 58 Exhibition display at the Mautsch gallery, Cologne 1993.

59 Alison Smithson putting the finishing touches to the exhibition.





60 Photos of the Hexenhaus on show in the Mautsch gallery during the first Tischleindeckdich exhibition in 1993. They are currently on show at the Hexenhaus.

make them less individual and more of an 'ensemble'. But judging by her letter to Axel Bruchhäuser dated 20 January 1993 (just four days after the official opening), she was apparently not very happy with the final result and suggested a great many alterations and changes for the next exhibition.

Despite Alison's apparent dissatisfaction with the result, press reports about the exhibition at the Mautsch gallery in Cologne were very positive, and all highlighted the intellectual dimension of the exhibition. The article entitled 'Bewitched' in the *Kölner Stadt-Anzeiger* daily was particularly revealing:

The image of the exhibition is a single whole. Colour and originality endow the objects with distance and absoluteness. [...] All instrumental purpose must be eliminated in order to see the exhibits as furniture and not merely as works of art. They are intellectually stimulating items. Anyone who enjoys inspiration and imagination must not miss this metallic green philosophy.

Alison prepared the display for the following exhibition in Berlin down to the very last detail, making adjustments to the lighting, the choice of exhibits and their arrangement in the gallery because, like in a travelling theatre, these were the tools available and deliberately 'like the director of a drama, we [the Smithsons] set up the staging and shift the actors and the lighting to try to uncover the mode of our time.'⁷⁷

One comment concerned the location of the furniture and its position in relation to the walls, a remark that had already been made about the Milan furniture fair when the Collector's Table and the Waterlily and Fish Desk were exhibited in 1986.

The furniture of the 1930s was either at right angles to, or parallel to, walls.

To lift the furniture into the 1990s we need to angle all at 45 degrees to walls.⁷⁸

She also suggested arranging the furniture in flotillas, i.e. like groups of boats sailing along together, because of their similar traits or purposes and because they belonged to a larger order, the fleet. Alison felt that 'the concept of flotillas indicates we are not after disposing furniture in rooms but creating a mood of furniture desire.'⁷⁹ The idea was also to highlight the groups behind the glass screens in the gallery by means of printer's cut-out circles that 'can cluster around each item and become fewer between items'.⁸⁰ (fig.70) Green cut-out circles were also used on the floor in Cologne but the desired effect was not achieved because they only surrounded some items and this highlighted their individual nature rather increasing the impression of a group. (fig.57)

As regards the position of the furniture, Alison suggested several alternative layouts for the Aedes gallery (fig.71 and 73) although the groups, referred to as flotillas, and

77 Peter Smithson, opening speech of the Tischleindeckdich exhibition at the Mautsch gallery.

78 Alison Smithson (1993, January 20). [Letter to Axel Bruchhäuser]. Alison and Peter Smithson Archives. TECTA Archive, Lauenförde.

79 Ibid.

80 Ibid.

the main items remained unchanged.⁸¹ She also pointed out that the spaces needed for the two Tischleindeckdich – the absolute centrepieces of that show – dictated the layout. The different flotillas were as follows:

- The flotilla consisting of three full-sized and one miniature Weissenhof chairs by Mies (1927) and a cluster of Silk Lanterns (Alison Smithson, 1991). Judging by the comment that Alison jotted on the plan, ‘Silk is connection to Mies’,⁸² this was an ideal group.
- The Smithson flotilla consisting of the Collector’s Table (1983), the Struwelpeter’s Wallcabinet (1986), the Trundling Turk (1953), the Housegarden (1991) and the leading light: the Tischleindeckdich in motion.
- The Breuer flotilla consisting of the folded Theatre Chairs (1926), the Folding Chair opened out and hanging on the wall (1927), and the Reclining Chair on Wheels (1928-1930) flying like an aeroplane in the middle of the vault.
- The Prouvé flotilla consisting of the Aeronautic Table (1924), two *Fauteuils de Grand Repos* (extremely comfortable armchairs) (1930) and some other mechanical pieces.
- The flotilla characterised by discreet singularity consisting of the Waterlily and Fish Desk (1986) and the Schlemmer Cabinet (1941).

The Tischleindeckdich tables were obviously the main exhibits that welcomed the visitors but once inside the gallery, the different angles of the furniture gradually made the public absorb the concepts of the different scenes, all within a harmonious atmosphere in which all the pieces of furniture were, as Alison said, ‘actors in a staging of the possible’.

As the photographs show, the lighting in the rooms of the Mautsch gallery was quite homogeneous because of the wall-washers mounted on tracks, but although efforts were made to reposition the lamps to illuminate the exhibits and cast shadows, the desired result was not achieved (fig.58). This incipient dramatic effect of light and shade increased considerably at the Aedes gallery where the lamps on the tracks were spotlights. This immediately made a big difference, and the effect was increased even more by the shadows cast onto the ceiling by green metallic Anglepoise lamps standing on the floor.

In Berlin, this play of light and shadow created an enveloping effect for the entire group because depending on the nature of each item, the lighting could be adjusted to cast shadows on the floor or the wall or the vault, or to highlight or blur certain items. This was the case, for example, of the lighting for the Waterlily and Fish Desk and the Schlemmer Cabinet which would have been eliminated from the exhibition if

81 The layout finally chosen for the furniture in the Aedes gallery was Alison’s second suggestion with slight variations.

82 The silk that Alison chose for the silk lanterns, the curtains and the upholstery was Dupion Silk or Dupioni, a type of natural silk woven with two threads, giving the fabric an incredible sheen. The character, beauty and unique nature of this fabric is also caused by the remainders of cocoons left in the thread and fabric which subsequently appear as small burls or strips in the fabric. No two lengths of Dupion silk are alike.



61 Partial view of the exhibition.

62 Exhibition display. Tischleindeckdich and the background.

it had not been possible to minimise their colouring and blend them into the metallic green atmosphere. Individual actions were eliminated for the sake of creating an ambiance.

Finally, the display in the Aedes gallery exceeded all expectations because it was ‘magically enhanced by the greenness of the glass of the permanent display screens’.⁸³ The display screens in the gallery were transparent, or at least seemed to be at first, but when they became part of the green ambiance created by the metallic green furniture and the greenish aura projected by the silk lanterns, the space was unexpectedly transformed.

The countless framing and mirror effects of the many layers of these glass screens became part of the exhibition display like a versatile tool doing much of the work for the presentation. They almost disappeared into the green ambiance and yet their reflections heightened their presence because, depending on their position (in front of, behind or slightly tilted), they enabled the furniture to be seen from many different angles and overlapping viewpoints, creating unexpected encounters and integrating visitors into a play of reflections that transformed them into yet another actor in the representation of this second act. ‘The glass screens have full play.’⁸⁴

The all-over greenness, the shadows and the reflections added up to an all-enveloping ambiance that extended beyond the boundaries of this ground-floor gallery underneath a railway and blurred the interior-exterior limit of the street outside, a particular trait that prompted the use of the Tischleindeckdich tables as an advertisement, as in the graphic design: ‘The Tischleindeckdich in motion catch people – especially children – walking along the passage outside ... act to bring them into the Galerie – as the side shows at the entrance bring people into the circus.’⁸⁵

Making the Tischleindeckdich the leading actor and the interface with the passageway made it possible to incorporate the outside world – the hustle and bustle of pedestrians and their character – naturally by the play of the indistinct reflections and transparency of the gallery’s windows. In addition, the layout, orientation and position of the furniture makes it obvious that they were intended to forge links with the street by creating an ‘ensemble’ quality that embraced the entire space. This aim was achieved for as Peter Smithson said, ‘in this showing, the greenness becomes ambiental, pervading both inside and outside, the air of the passage becoming green.’⁸⁶

Unfortunately, Alison was unable to see the result of all her work, the transformation of the gallery and the furniture on show into an ensemble, because she was already ill and unable to attend the opening of the exhibition. She died just a few months later on 16 August 1993. In his opening speech, Peter Smithson explained her and his

83 Peter Smithson, “Tischleindeckdich” at Galerie Aedes’.

84 Ibid.

85 Ibid.

86 Ibid.

contribution:

The furniture pieces on show here were selected by Axel Bruchhäuser of ΤΕΣΤΑ and by Alison Smithson; the invitation catalogue and the arrangement of the gallery are both by her. I have acted in Berlin only as a kind of circus ringmaster. But circus is a false analogy, for the circus performs in the same 'big top' in every town. This show is more like a travelling theatre.⁸⁷

A theatre travelling from town to town which managed, upon arriving in Berlin, to present once again, in a forum of importance for the architectural culture of that time, 'a "staging of the possible"... a staging to illuminate an ideal for the immediate future'.⁸⁸ A metallic-green coloured philosophy.

87 Ibid.

88 Alison Smithson, *Tischleindeckdich (exhibition catalogue)*.



63 Peter Smithson commenting on the exhibition during the opening ceremony at the Aedes gallery.

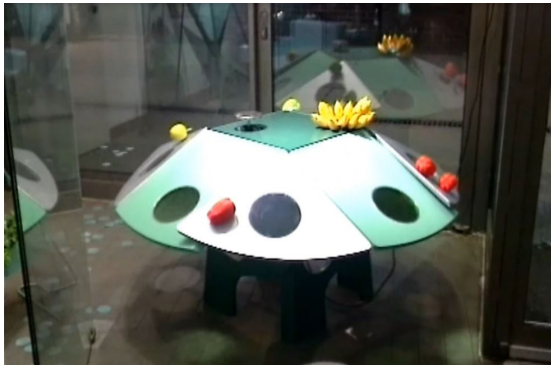

64-67 Tischleindeckdich table opening up at the Aedes gallery.

68 Drawing by Alison Smithson showing the position of the fruit on the table.

69 Children attracted by the movement of the Tischleindeckdich. (Photo: Peter Smithson).

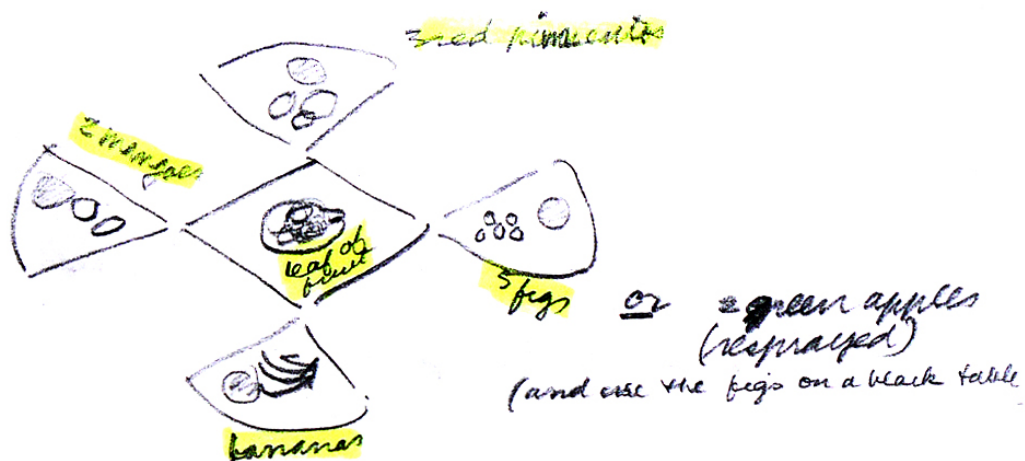

70 The three green Weissenhof cantilever chairs (Mies van der Rohe, 1927) at the Aedes gallery.

71 Sketch of layout No. 1 for the furniture on show at the Aedes gallery. Alison Smithson (annotations by Axel Bruchhäuser).

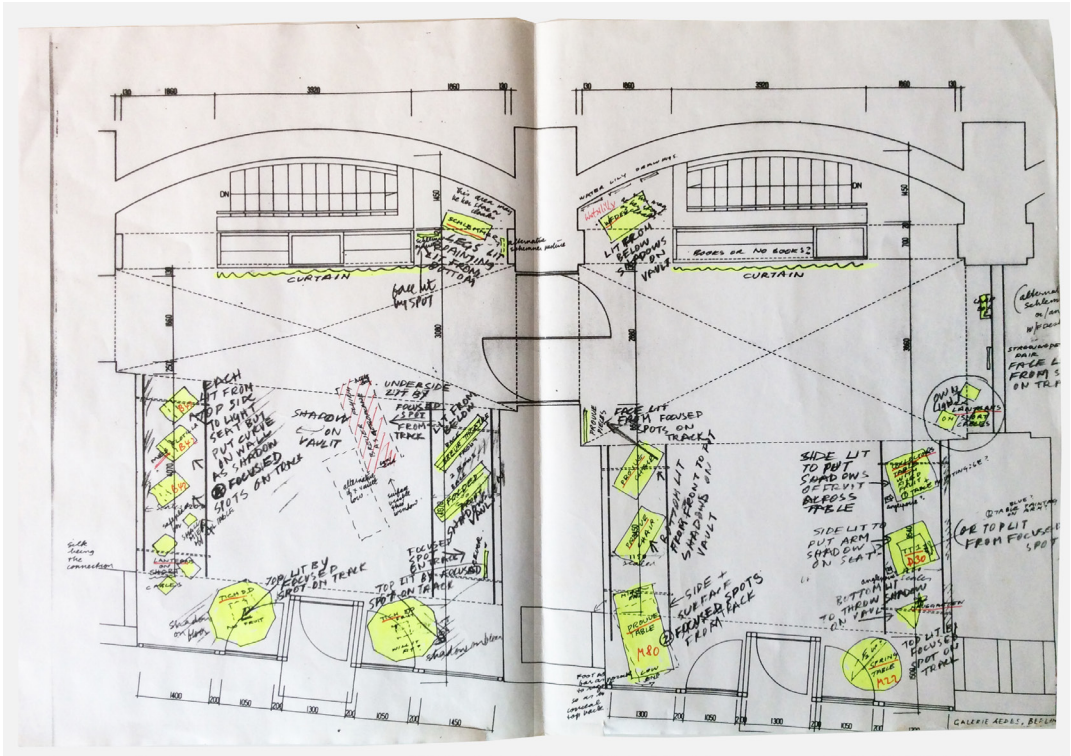

72 General view of the installation at the Aedes Gallery.

73 Sketch of layout No. 2 for the furniture on show at the Aedes gallery. Alison Smithson (annotations by Axel Bruchhäuser).

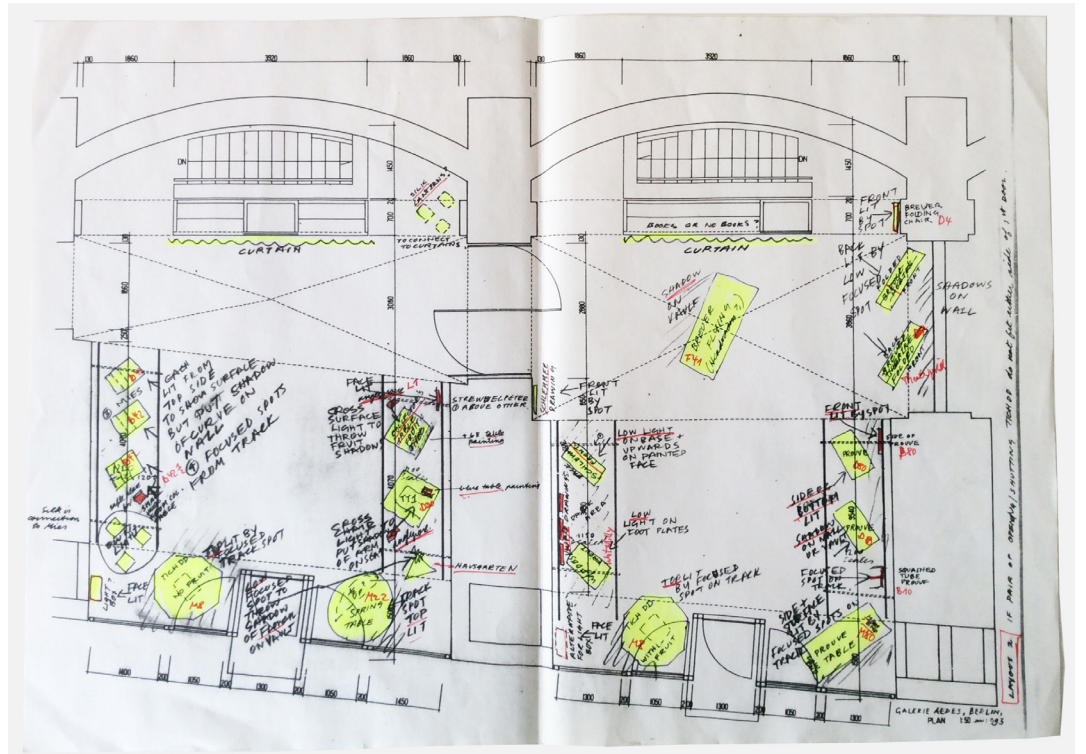



74-79 Views of the exhibition opening at the Aedes gallery.



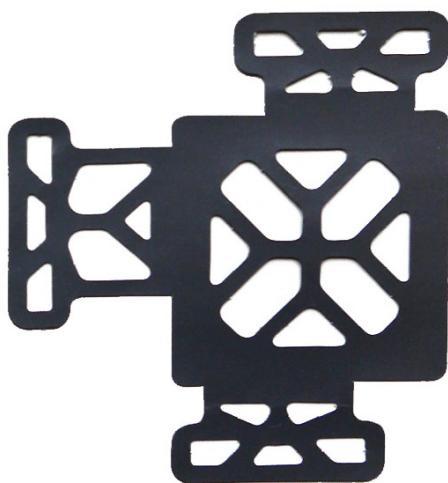
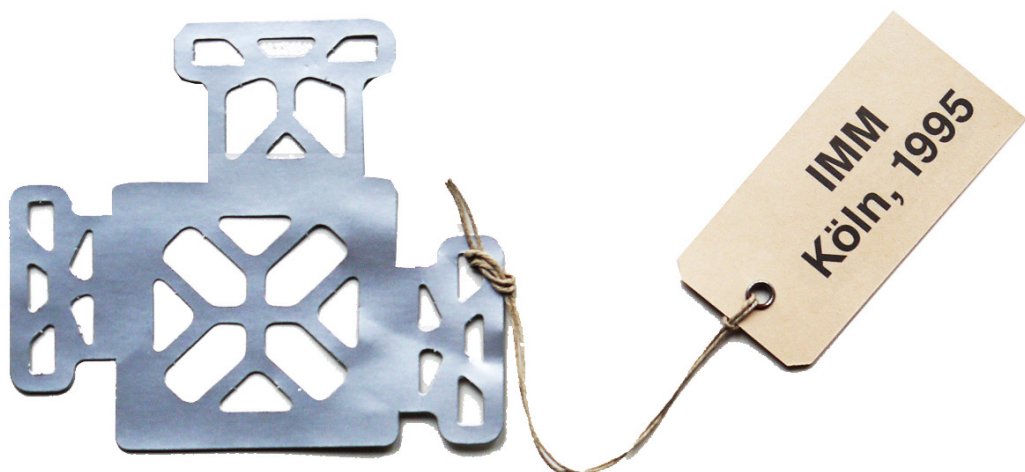

80 Invitation to imm Cologne, 1995.

Cologne International Furniture Fair (imm Cologne)

Peter Smithson

1995

Event, venue and date: imm Cologne. Kölnmesse, Cologne. January 17-22, 1995.

Organizers: TECTA

Design: Peter Smithson

Work team: -

Gross floor area: -

Itinerary: -

Exhibition catalogue: -

Related publications: -

Additional information:

Invitation: Trundling Turk II. Peter Smithson

16.01.1995 'Staging the Possible'. Private conference at the Dom Hotel for TECTA by Peter Smithson

Reviews: -

The close collaboration between Alison Smithson and TECTA continued and even increased following her death in the summer of 1993. Peter took over the projects still on the drawing board, such as the Trundling Turk 2, and also began new lines of research in all the spheres they had been working on, i.e. furniture designs and exhibitions and also the Hexenhaus and the factory in Lauenförde.

The 1995 Furniture Fair of Cologne was the venue chosen to launch at last the Trundling Turk they had been working on for more than ten years. The armchair was by far the leading light of the fair and the fair invitation itself was its visiting card: a miniature replica of the chair's structure made of embossed, silver grey card (the same silver grey used for the mute invitation of 1992). A small work of art in the form of another *serious toy* that beckoned the beholder to fold and play with the invitation before coming face to face with the actual item at the fair.

The armchair exhibited by TECTA and Peter Smithson was a new version of the Trundling Turk of 1976 featuring a single sheet of bent, laser-cut stainless steel instead of the four pieces of bent plywood in the original structure for an even more streamlined design. This basic structure or enabling frame now in the limelight was even exhibited without any upholstery, simply waiting for the appropriations of each future user. In addition, the bare structure enabled the beholder to appreciate its asymmetric form stripped of all rigidity and motionless even more. As Alison said, this structure 'encourages us to sit differently, to recline more expansively, to respond to our greater freedom of social behaviour'⁸⁹

89 Alison Smithson, 'Into the Air', p. 9.

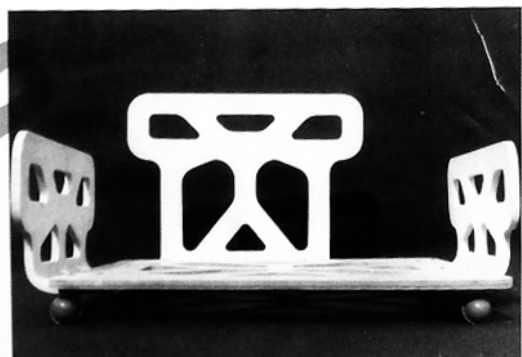
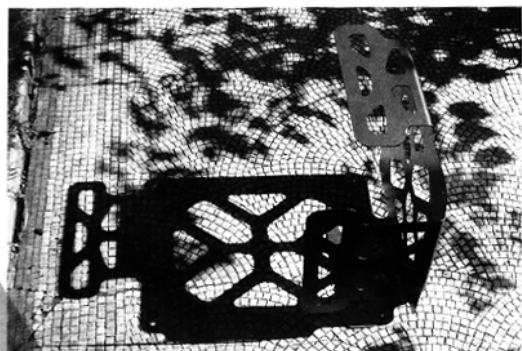
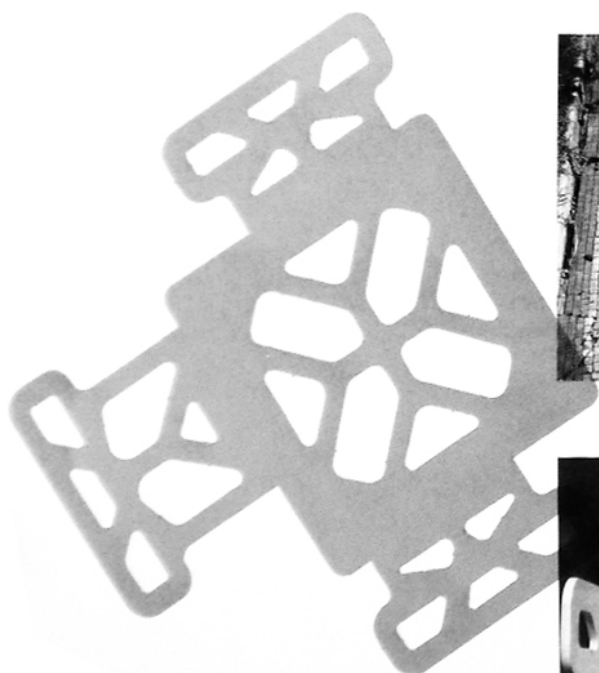
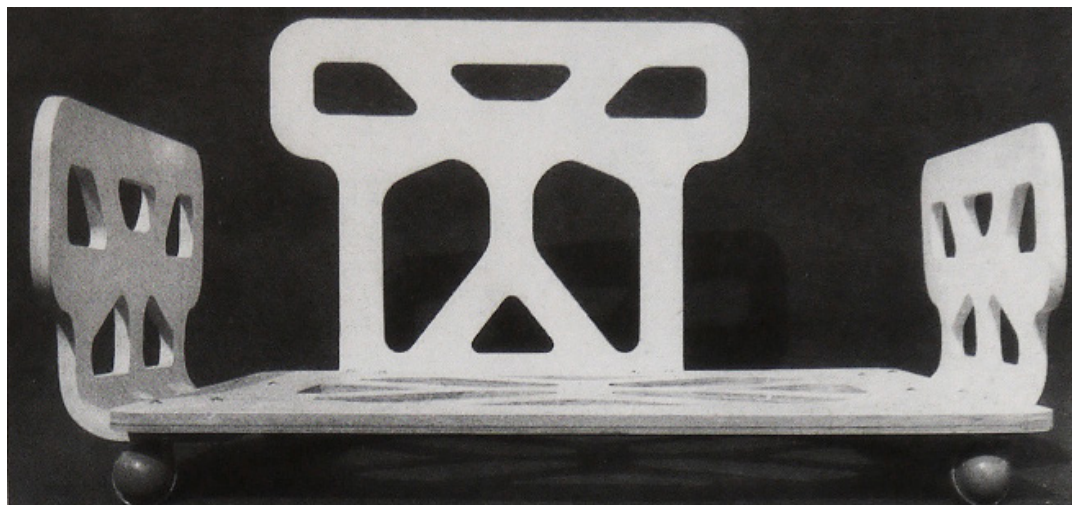

81 and 82 Trundling Turk II. Alison & Peter Smithson, 1976. ТЕСТА version, 1994.



83 Cover of the On the Floor Off the Floor exhibition catalogue - invitation.

On the Floor Off the Floor

Peter Smithson

1998

Venue and dates: Janine Mautsch gallery, Cologne. January 19–February 28, 1998.

Organizers: TECTA

Design: Peter Smithson

Work team: -

Gross floor area: 25 sqm (aprox.)

Itinerary: -

Exhibition catalogue: Peter Smithson 'On the Floor Off the Floor'

Related publications:

Peter Smithson 'Lattice Screens and Paravents' (text inside the catalogue)

Additional information: Part of Passagen (Interior Design Week Cologne)

Reviews: -

The 'On the Floor, Off the Floor' exhibition was part of 'Passagen', Germany's largest design event held every year since 1990 in Cologne. This event, also known as the Interior Design Week of Cologne, is held at the same time as the International Furniture Fair but at different venues in the city of Cologne and its metropolitan area, and features exhibitions and events focusing particularly on current trends in interior design. En 1998, Passagen was held from on January 18 - 25 although Peter Smithson's exhibition at the Mautsch gallery continued for another month.

This is the first exhibition display designed by Peter Smithson alone after Alison's death in 1993 and it consists entirely of pieces of furniture made by ТЕСТА to explain how furniture is a vehicle for lifestyle and 'plays with the influence of old and young age on contemporary seating solutions and everyday culture'.⁹⁰

On the one hand, the exhibition shows the 'on the floor' way of living:

It has been observed that student life is conducted largely on the floor... bed, books, conversation, even cooking, certainly eating, takes place there... for without money all is thus simplified. The young can kneel, sit on their feet, get up in a single movement. Thus, furniture designed by the young tends to be low... the mythical plank on two bricks of Marcel Breuer in his Bauhaus time, the early plywood furniture of the Eames, the Trundling Turk.⁹¹

This young outlook was reflected in two of Alison and Peter Smithson's furniture designs: the Trundling Turk (originally designed when they were 25 and 30 years old respectively) and Her Box (1985), exhibited like an occasional piece of furniture that could be used as a table, storage box, display cabinet, etc.

But it was also necessary to cater for the seating conditions of the 'off-the-floor' way of life:

Older people with stiffer legs and more precious possessions rise higher... to the MR chairs of Mies van der Rohe or the spartan metal-framed "back-rest" chair of Marcel Breuer, and they need tables and desks and secure storage to match.⁹²

This second approach to furniture is embodied in the Weissenhof chair (1927) by Mies van der Rohe and Erich Brendel's Bauhaus table (1924).

The layout on the cover of the catalogue-invitation shows the two chairs in pride of place because the 'tables' are apparently just two plain, discreet cubes. Peter Smithson had already mentioned his fascination with Brendel's table in the "Tischleindeckdich a.s.o." exhibition catalogue: 'From my first sighting of the cube table by Erich Brendel [...] I have felt that it held a persistent magic.' This table also unfolds and changes like the poetical Tischleindeckdich designed by Alison and, in a way, like Her Box, her equivalent of the on-the-floor lifestyle. The apparent simplicity of these two pieces of furniture shifts all prominence onto the absent inhabitant represented by the chairs, whilst opening up a full gamut of possibilities for the appropriation by users in

90 'On the Floor Off the Floor', *Passagen* (Cologne, 1998).

91 Peter Smithson, *On the Floor Off the Floor* (exhibition catalogue), 1998.

92 Ibid.

each mode of use.

The off-the-floor exhibit is enhanced by Gerrit Rietveld's Hanging Lamp (1922). The lighting is very important because 'continuing this thought; giving lighting *on the floor* or lighting *off the floor* can change the pattern of use of a space.' The lighting changed the perception of space considerably: whilst Rietveld's lamp lit (mainly) the table in the off-the-floor lifestyle, a tray of candles lit the floor in the on-the-floor lifestyle, the floor being its versatile sphere of use. The same thing would happen in a space with natural lighting because architecture should in itself indicate and enhance use.

There are obviously parallels between the theme of the exhibition and the windows Peter made that year on the first floor of the Hexenhaus. Axel Bruchhäuser's bedroom overlooks the landscape and a panoramic window almost at floor level softly lights the floor, enabling the room to be enjoyed from a surprising new viewpoint. 'Perhaps the floor then becomes a place of use, as in one's student days.'⁹³ In the workroom, however, a similar panoramic window but off the floor lights the desk. Two virtually identical windows but in different positions that transform the perception of space and encourage inhabitants to enjoy two different lifestyles: on the floor, off the floor.⁹⁴

The experimental Hexenhaus and remodelling of the ТЕСТА factory were also the basis for the Lattice Screen and Paravent designed by Peter Smithson in 1997 and put on show at the same exhibition. Standing between the on-the-floor and off-the-floor lifestyle areas is this folding screen, a discreet but important element of the stand and the text on the back of the catalogue too. The catalogue itself is, in fact, a folding screen too: silver on the outside featuring the on-the-floor and off-the-floor concepts, and white on the inside featuring the words 'Lattice screens and paravents' together with useful information about the exhibition. Peter Smithson called the catalogue the 'Paper Paravent'.

The lattice – now mobile – pursues the line of thought started in the 1970s but with new variables. One important aspect of this new element is that 'to conceal, or to part-conceal, or to display is achieved by the movement of the lattice not by the movement of the person behind the lattice',⁹⁵ enabling the structure to be appropriated in different ways by one or more users over time. 'Assuming a certain solidity in the lattice we are conscious of seeing segments, segments which isolate objects or collections of objects so we see them strongly... a screen moves, we see different segments'.⁹⁶ This mechanism enables different degrees of protection but also enables different viewpoints or interactions, multiplying the ways of looking at any given landscape or scenario. In a way it is the construction of a metaphor: tree branches. 'Tree branches move and grow, changing what is seen through them

93 Andrew Mead, 'Putting Down Roots', *The Architects' Journal*, 214 (2001), 26–35 (p. 29).

94 The exhibition catalogue contains a photo of the on-the-floor window in Axel Bruchhäuser's bedroom with the comment: 'It would seem logical that for an *on the floor* use the floor should be well lit as it is the working-surface and that for *off the floor* use the desk/table level needs the best light'.

95 Peter Smithson, *On the Floor Off the Floor (exhibition catalogue)*.

96 Ibid.

without the observer moving.⁹⁷

In the Mautsch gallery exhibition, the lattice-screen separates and links two lifestyles, suggesting countless differences and similarities between the two – yet another installation intended to provide food for thought and not merely to decorate a room or exhibit individual items, as was also the case of the earlier ‘Tischleindeckdich a.s.o.’ exhibition.

In fact, both exhibitions have many things in common ranging from dramatic lighting to the small Trundling Turk armchairs used previously for the invitations to the Cologne Furniture Fair of 1995 and now scattered over the floor of the room, blurring its boundaries. But the most eye-catching element in common is perhaps the use of colour. In 1993 Alison created a metallic green atmosphere which was substituted in the Mautsch gallery by a metallic silver ambiance pursuing the idea that ‘the colours of furniture would be softer – metallic green, aubergine,’ with a homogeneity that blurred the individual nature of each piece of furniture, enabling them to coexist and build up to form an ensemble. Originally, everything was bathed in the same silver colour including the floor (now part of the exhibition), but as work continued, two red items were included. However, far from distorting the atmosphere, they heightened the composition of the exhibition even more. The resulting display was like an artistic installation, and its photo in the catalogue like an abstract painting.

Peter Smithson asked Axel Bruchhäuser for an overhead photo, a kind of aerial view of the Mautsch layout for the catalogue and, in the words of Axel, ‘Therefore I organized from our roofmaker a big crane. We sewed the floor carpet in silver silk and took the photo from a height of ten meters for the invitation card’.⁹⁸ A very unusual viewpoint that makes objects look flat and highlights their shadows, reconstructing each object and the surrounding air, whilst adding a time factor and fleetingness. An overhead image reminiscent of Peter’s photo of the sewing room porch at the ТЕСТА furniture factory taken looking down from the roof which he called ‘the El Lissitzky view!’⁹⁹

There are obvious similarities between some of El Lissitzky’s works and the ambiguous, suggestive image chosen to illustrate the exhibition catalogue-invitation, and in a way the touch of red on a neutral ground was reminiscent of the work of Russian constructivists.

In short, in his desire to unify painting and architecture, in approximately 1919 El Lissitzky created his first of his *prouns* (an acronym for a design entailing the confirmation of the new) – his main contribution to the art world.¹⁰⁰ Prouns are geometric compositions with striking spatial and architectonic effects in which

97 Ibid.

98 Axel Bruchhäuser (2015, May 14), email to the author.

99 Said photo and remark appear in Peter Smithson article, ‘Empooling’, *ILAC&UD Yearbook 1996*, 42–45.

100 His principles had a profound influence on the members of the Dutch group De Stijl and Bauhaus in Weimar, Germany, for example.

the artist abandoned all conventional laws of perspective. 'He coined the new word *proun* to signify this innovative form of creative work, part painterly, part architectural and part graphic, and capable of application in any of these fields of activity.'¹⁰¹

Peter Smithson's compositions are similar to El Lissitzky's prouns not only in appearance but also as regards the underlying concepts. In 1920 El Lissitzky published 'Theses on the Proun: From Painting to Architecture' in which he said:

We have named Proun a station on the path to the construction of the new form.

[...] We see that on the surface (plane) of the picture, the Proun ceases to exist as such and becomes a building surveyed from every direction — considered from above or examined from below. The result of this turns out to be the destruction of the single axis that leads to the horizon.

[...] The Proun opens up the creation of the future, encompassing in all directions the new creative collective: starting from the plane, it then crosses over into spatial modelling and further to the construction of every form of life in itself.¹⁰²

In an intriguingly similar manner, the 'On the Floor Off the Floor' exhibition is a 'project for the affirmation of the new', as El Lissitzky said, that starts with furniture and then crosses over into architecture and finally into 'the construction of every form of life in itself'.

101 Oxford University Press, 'Vitebsk, Suprematism and the "Proun" Works, 1919-21' <http://www.moma.org/collection/browse_results.php?criteria=O%3AAD%3AE%3A3569&page_number=1&template_id=6&sort_order=1§ion_id=T051360#skipToContent> [accessed 16 January 2015].

102 El Lissitzky, 'Theses on the Proun: From Painting to Architecture' <<http://thecharnelhouse.org/2013/09/16/proun/>> [accessed 18 January 2015].

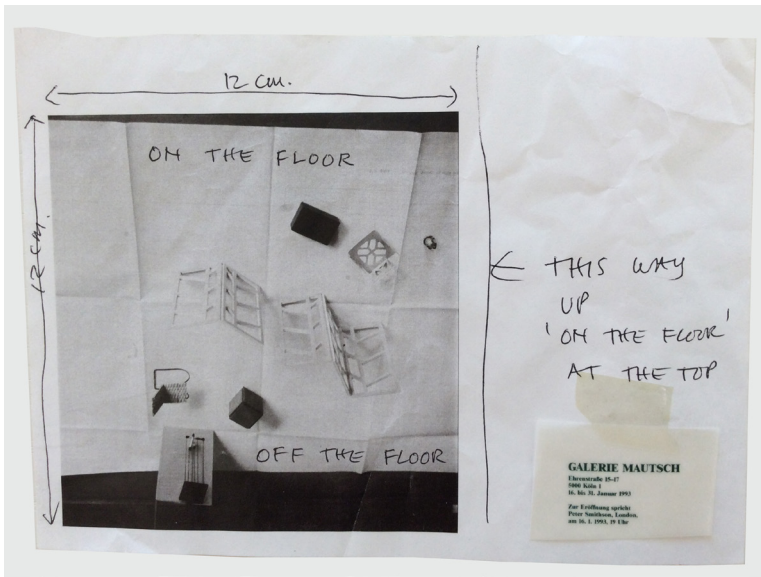

84 Aerial view of the Mautsch layout proposed by Peter Smithson and attached to his letter.

85 El Lissitzky, *Proun 1C* [Oil on panel]. Thyssen-Bornemisza museum, Madrid (1919).

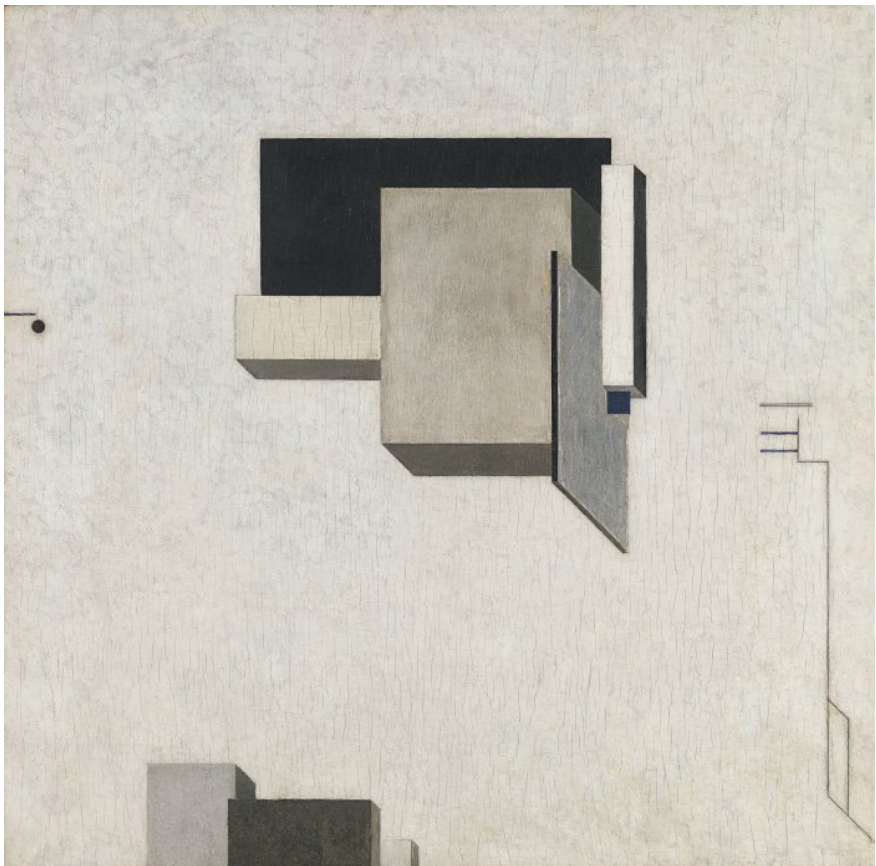

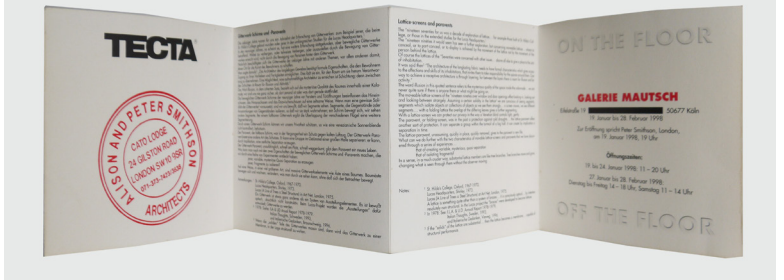
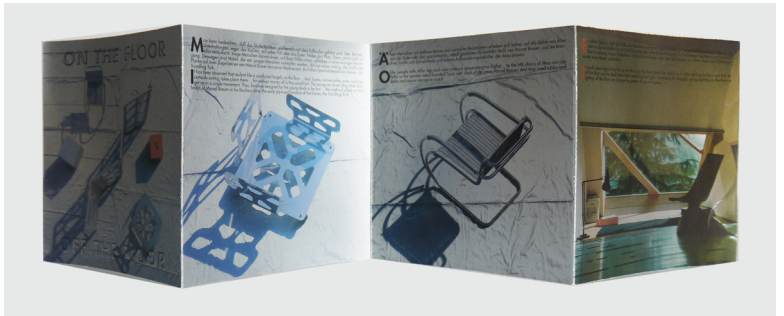

86-89 'On the Floor Off the Floor' exhibition invitation-catalogue designed by Peter Smithson as a paravent.

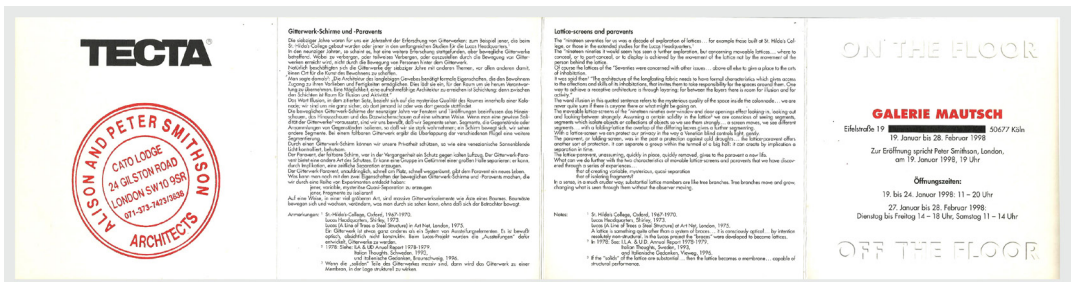
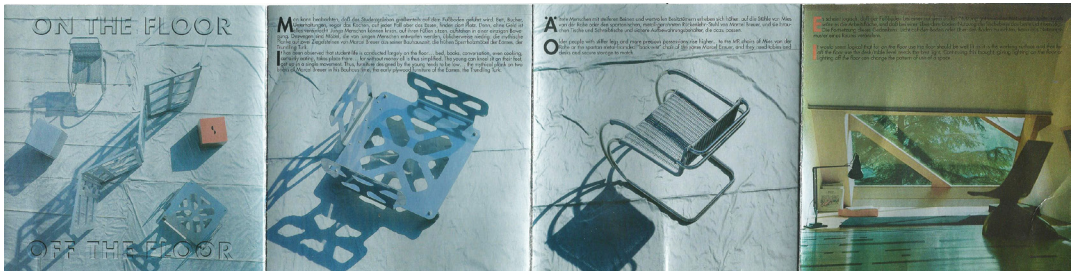

Man kann beobachten, daß das Studentenleben größtenteils auf dem Fußboden geführt wird. Bett, Bücher, Unterhaltungen, sogar das Kochen, auf jeden Fall aber das Essen, finden dort Platz. Denn, ohne Geld ist alles verflüchtigt. Junge Menschen können knien, auf ihren Füßen sitzen, aufstehen in einer einzigen Bewegung. Daswegen sind Möbel, die von jungen Menschen erwartet werden, üblicherweise niedrig, die mythische Plank auf zwei Ziegelsteinen von Marcel Breuer aus seiner Bauhauszeit, die frühen Sperrholzstühle der Eames, der Trundling Turk.

It has been observed that student life is conducted largely on the floor. ... bed, books, conversation, even cooking, certainly exciting, takes place there ... for without money all is thus simplified. The young can kneel sit on their feet, get up in a single movement. Thus, furniture designed by the young tends to be low ... the mythical plank on two bricks of Marcel Breuer in his Bauhaus time, the early plywood furniture of the Eames, the Trundling Turk.

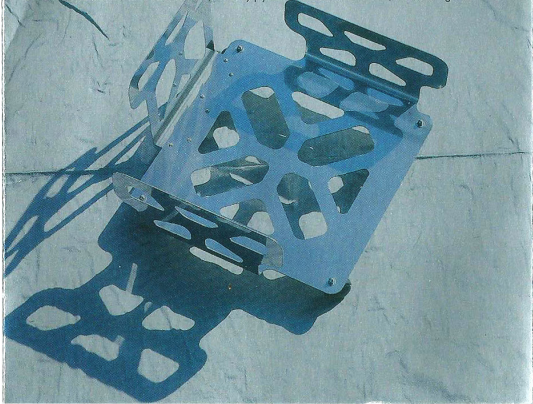

Ahere Menschen mit steiferen Beinen und wertvollen Besitztümern erheben sich höher: auf die Stühle von Mies van der Rohe oder den spartanischen, metall-gerahmten Rückenlehne Stuhl von Marcel Breuer, und sie brauen Tische und Schreibtische und sichere Aufbewahrungsbehälter, die dazu passen.

Older people with stiffer legs and more precious possessions rise higher ... to the MR chairs of Mies van der Rohe or the spartan metal-framed "back-rest" chair of the same Marcel Breuer, and they need tables and desks and secure storage to match.



90 Inside pages of the invitation-catalogue showing seating solutions for the On the Floor Off the Floor lifestyles.

91 The softly lit floor encourages visitors to enjoy the on-the-floor lifestyle at the Hexenhaus.

92 Panoramic window over Axel Bruchhäuser's desk at the Hexenhaus.



93 View through paravents at the Mautsch gallery.

94 The Trundling Turk II in the 'On the Floor Off the Floor' exhibition.

95 Aerial view of the exhibition stand at the Mautsch gallery from the 'On the Floor' side.

96 Overview of the display from the 'Off the Floor' side.



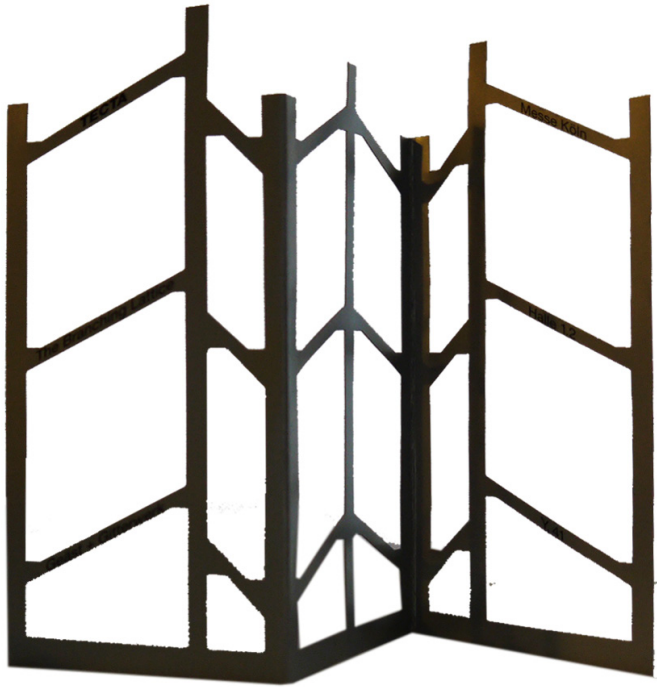

97 and 98 Invitation to the Lattice
Furniture stand at imm Cologne, 1999.

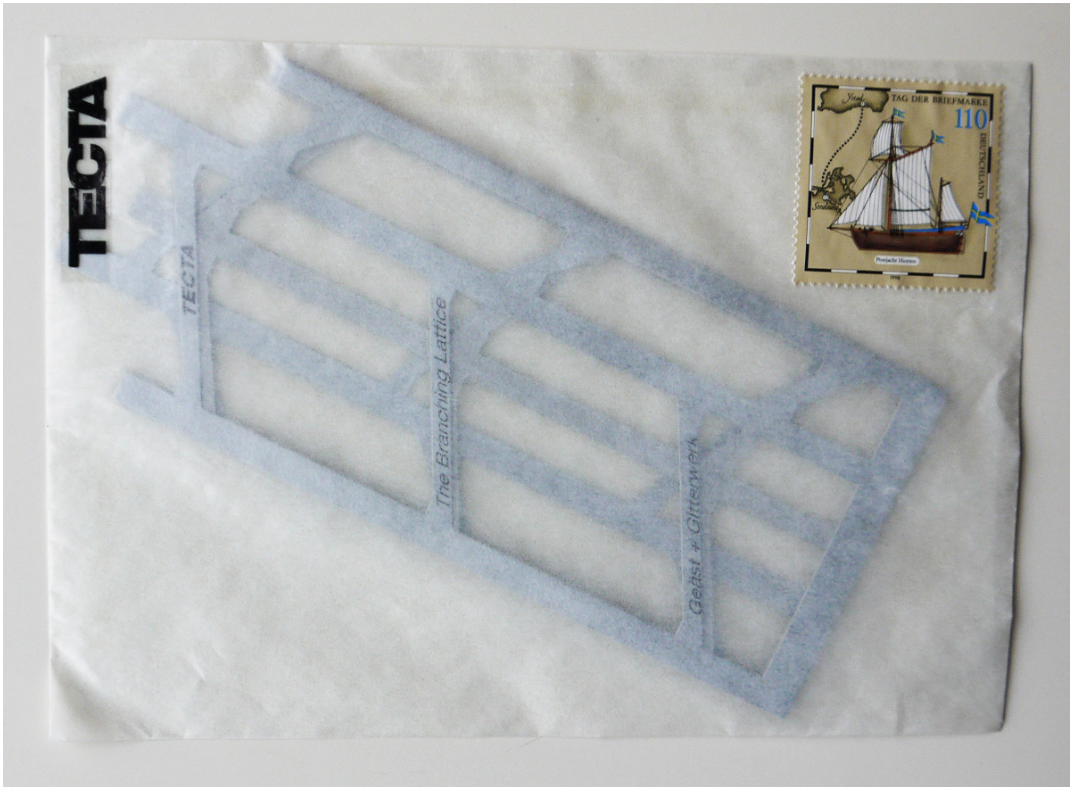

Lattice Furniture Stand Cologne International Furniture Fair (imm Cologne)

Peter Smithson

1999

Event, venue and dates: imm Cologne. Kölnmesse, Cologne. January 18-24, 1999.

Organizers: TECTA

Design: Peter Smithson

Work team: -

Gross floor area: -

Itinerary: -

Exhibition catalogue: -

Related publications: -

Additional information: 'The Branching Lattice by TECTA' invitation by Peter Smithson

Reviews: -

Once again the International Furniture Fair of Cologne was the venue chosen to present ТЕСТА's latest collection of furniture – Lattice Furniture – designed in this instance by Peter Smithson. This series consisted of the Lattice Paravent (1997) (shown the year before at the 'On the Floor Off the Floor' exhibition), the Lattice Cupboard (1998), the Lattice Chair or Trundling Turk III (1998), the Lattice Sofa (1998) and the Lattice Table (1998).

All these pieces of furniture, as their names suggest, were part of the research into lattices begun in the 1970s, which is why they were shown together at ТЕСТА's Lattice Furniture stand during what could also be described as the lattice year. In January 1999, in parallel with this exhibition, Peter Smithson penned 'The Lattice Idea', an essay subsequently published in *ILAC&UD 1999*, the yearbook of the International Laboratory of Architecture and Urban Design founded by Giancarlo di Carlo. In that essay, Peter Smithson reviewed the work carried out on the lattice concept since the 1970s, when the Smithsons were building St Hilda's College (1967-1970) and designing the Lucas Headquarters (1973), up to the moment when the lattice became part of their furniture designs.

Said work was a series of cumulative experiments beginning with braces that evolved into fixed lattices and gave rise to the lattice architecture of the 1970s. Following the re-activation and further exploration of this concept in the early 1990s, work began on movable lattices: firstly in the form of lattice screens, then as lattice paravents, and finally in the late 1990s as furniture on a small scale. Like the work on lattices, the essay was also built up iteratively. It includes the concept begun in the 1978 essay 'Some Further Layers' (1978) plus the idea of using lattices as screens and paravents that featured in the 'On the Floor Off the Floor' exhibition catalogue (1998) – which already included the earlier concepts from the 1970s – and also the new viewpoints that led to furniture being added to this line of research.

The furniture collection exhibited at Cologne, despite forming part of what was called lattice furniture, featured two completely different ways of working with lattices which echoed the Smithsons' earlier developments. The underlying strategy of the Lattice Paravent and the Lattice Cupboard was based on the same ideas as the lattice screens used for doors and windows, i.e. 'to select out visually items of the inside for the outside' to become respectively 'a sense of protection' and a 'cupboard of display'.¹⁰³ The lattice screens tried out in the porches of the Hexenhaus, the ТЕСТА factory and the Brodia Road project are interfaces between the indoors and the outdoors. By subsequently using them in furniture, these screens enabled users to separate and yet selectively combine two areas into a single space. 'To perform in this way, the lattice bars have to have a certain thickness, which has the effect of isolating and intensifying the fragments seen through the lattice [...] as the frame effects the sense of space in a picture.'¹⁰⁴ In other words, first and foremost a visual mechanism.

In the case of the Lattice Chair, Table and Sofa, however, the lattice became a

103 Peter Smithson, 'The Lattice Idea', *ILAC&UD Yearbook 1999*, 58–61.

104 Ibid.

support frame or kind of scaffolding. The structural frame of this furniture collection was separate, simplified and rationalised, and acted as an enabling frame: 'an interplay between the fixed lattice frame and the pattern of the cushions within'.¹⁰⁵ Both elements, the frame and the cushions, the frame and the content, were important and contribute to the design. 'The carrying framework is a tubular, stainless-steel lattice part "aplati" cantilevering at the corners [in the case of the chair and the sofa] with its joints visually consolidated with caning.'¹⁰⁶ The cushions were a tribute to the Russian artist Liubov Popova. This was obvious at the exhibition because of the prominence which the Lattice Furniture Stand gave to her design for 'Production Clothing for Actor no. 7' which featured in Fernand Crommelynck's play *The Magnanimous Cuckold* (1921).¹⁰⁷

The female Russian artist Liubov Popova originally focussed on painting and believed the construction of paintings to be the stage prior to three-dimensional construction. She subsequently worked in industry and developed a noteworthy career in theatre and fabric design. She designed the costumes and sets for *The Magnanimous Cuckold*, which had a great impact because it featured the first constructivist sets. Popova's costumes for the actors consisted of overalls with brightly coloured geometric designs which, like her paintings, created a constructivist composition of the body. The overlapping geometric shapes organised the elements not as a vehicle for the imagination but as independent constructions.

Peter Smithson echoed this experimental approach with geometric lines and colour blocks in space – not merely as compositions but as three-dimensional constructions based on geometry and 30°, 45° and 60° angles – in the upholstery he designed for the Lattice Chair and the Lattice Sofa. Even the colours of the cushions – black and blue, blue, white and red – were very similar to those of Popova's famous costume designs for *The Magnanimous Cuckold*. In addition, Popova's view that the two-dimensional construction of canvas and fabric patterns and costume design, etc., as the stage prior to three-dimensional construction, is very similar to the 'branching lattice' concept developed by the Smithsons. Consequently, although the frame and contents of the Lattice Chair and Lattice Sofa may seem quite different, they have not only visual but intellectual considerations in common.

105 Ibid.

106 Smithson and Unglaub, p. 46.

107 Liubov Popova (1889-1924) is considered, together with Malevich, Tatlin and Rodchenko, to be one of the most well-rounded artists of the Russian avant-garde. She was part of both the Suprematism and Constructivism movements for she could see no contradiction between the two, and remained true to her beliefs until the end of her days. Along with Rodchenko, Stepanova, Exter and Vesnin, she took part in the '5x5 = 25 exhibition' (Moscow, September 1921) which announced 'the death of the painting and the end of contemplative art'. Popova then gave up easel painting and moved into graphic design, textile design and sets and costumes for the theatre, and began teaching at *vkhutesmas* (higher and artistic workshops) and at Moscow's Inkhuk (institute of artistic culture). The Museum of Modern Art of New York, the Los Angeles County Museum of Art, the Ludwig Museum in Cologne and the Museo Nacional de Arte Reina Sofia, Madrid, hosted a travelling retrospective exhibition of this artist in 1991 and 1992 entitled 'Liubov Popova 1889-1924'.

The branching lattice is the element that all the items on the stand have in common, and is also the title of the invitation to the Cologne exhibition: 'The Branching Lattice. Branches + Latticework'. In addition, the invitation itself is a small branching-lattice paravent made of silver card similar to both the paper paravent designed for the 'On the Floor Off the Floor' invitation/catalogue, and the invitation to the Cologne fair of 1995 in the shape of the little Trundling Turk II.

Peter Smithson ended the 'Lattice-screens and paravents' article in the 'On the Floor Off the Floor' invitation/catalogue with the following words: 'In a sense, in a much cruder way, substantial lattice members are like tree branches. Tree branches move and grow, changing what is seen through them without the observer moving.' This mechanism blurs the boundary between the three-dimensional outside and its two-dimensional, built boundary, making it disappear.

Modifying the Hexenhaus, the Smithsons followed a clearly consequential strategy, starting with a two-dimensional figure to obtain a three-dimensional form. [...] This abstract profile of natural origin – the branching lattice – is utilized as a frame to separate interior and exterior in all the opening of the house [...] capable of creating a relationship between the things they are actually separating.¹⁰⁸

Branches and latticework merge together in the branching lattice – as revealed by the mere presence of 'Actor no.7' dominating ТЕСТА's Lattice Furniture stand at the International Fair of Cologne.

108 Maddalena Scimemi, 'Alison E Peter Smithson: La Hexenhaus', *Casabella*, 2004, 7–21. Published in English in Max Risselada, ed., Alison and Peter Smithson: A Critical Anthology (Barcelona: Ediciones Polígrafa, 2011). (p.380).



99 Structure of the lattice sofa alongside Popova's *Actor n°7* at ТЕСТА's Lattice Furniture stand, 1999.

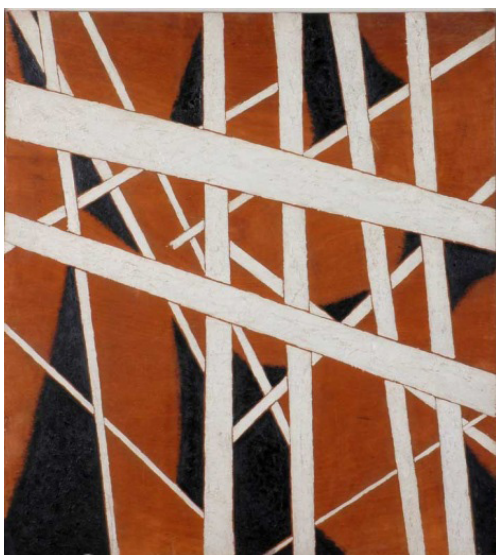

100-102 Liubov Popova, *Production Clothing for Actor no. 2, 5 and 7* in Fernand Crommelynck's play *The Magnanimous Cuckold* [gouache, indian ink and collage on paper]. Private collection, Moscow (1921).

103 Liubov Popova, *Stage Set Design for the Play The Magnanimous Cuckold* by F. Crommelynck, Meyerhold Theatre, Moscow. (1922) Photograph of Popova's machine in production.

104 Popova's *Studies for a Construction in Space* outlines her move from the two dimensions of her Space Force Constructions into the three dimensions of her production and theatre work.

105 Liubov Popova, *Space Force Construction* [oil, with sawdust on plywood]. State Museum of Contemporary Art, Thessaloniki, The George Costakis Collection (1921).

106-109 Set of drawings:

The Lattice Cupboard, Peter Smithson 1998.

The Lattice Table, Peter Smithson and TECTA, 1998.

The Lattice Sofa, Peter Smithson and TECTA, 1998.

The frame. The Lattice Chair, Peter Smithson and TECTA, 1998.

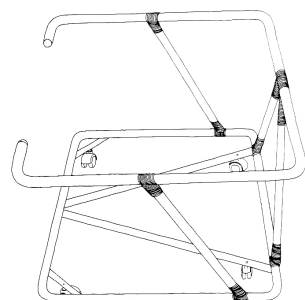
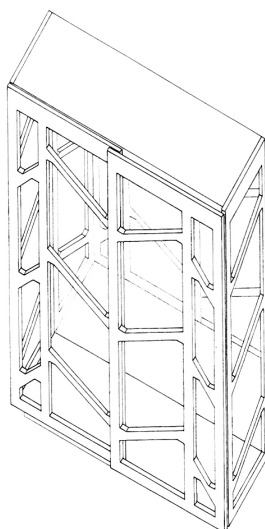
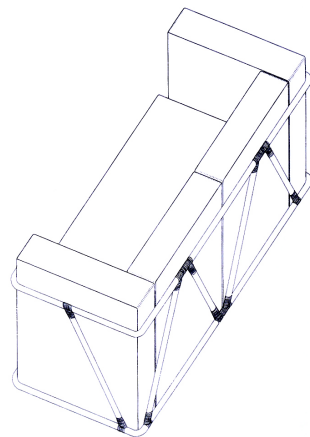
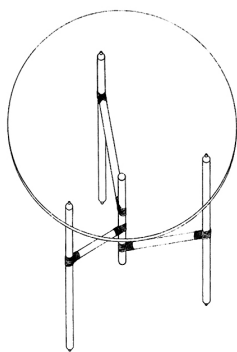

110 The Lattice Table, Lattice Chair and Lattice Sofa on TECTA's Lattice Furniture stand, 1999.

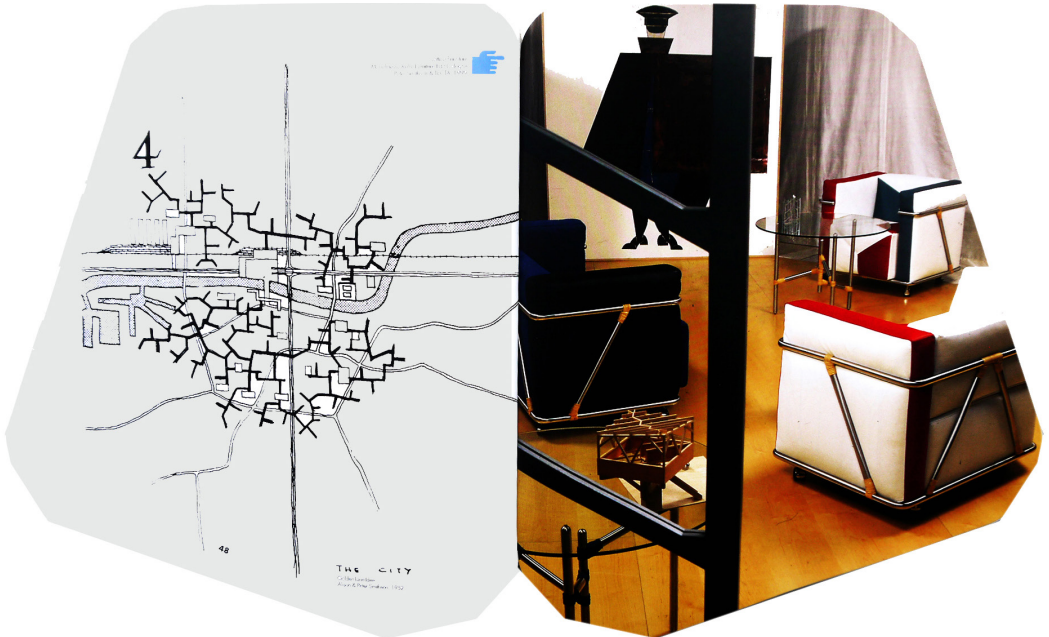
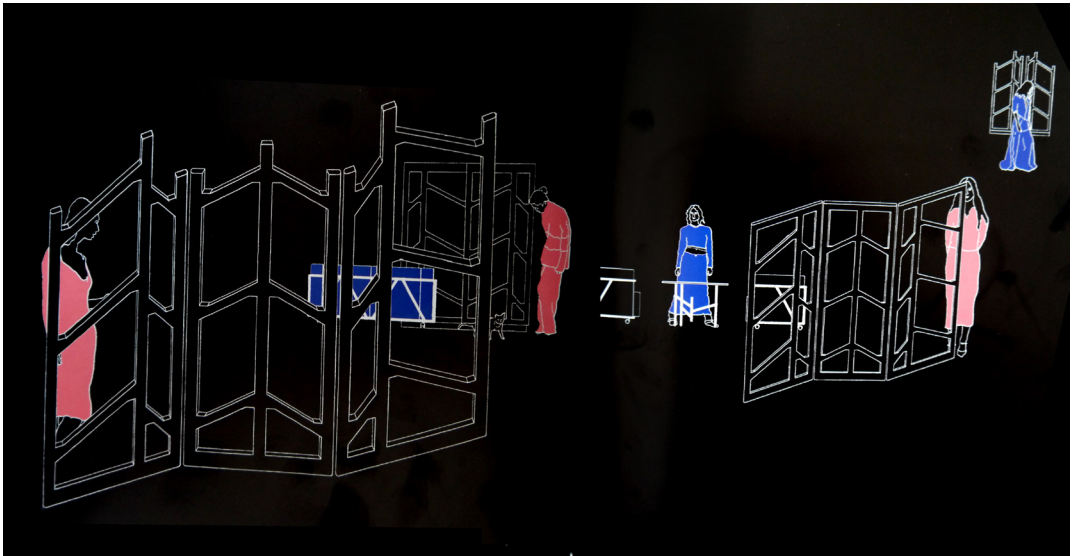

111 The Lattice Furniture displayed in a way similar to the Interdesign 2000 furniture competition, exhibited by Alison and Peter Smithson in 1976.

112 Inside pages of the book "Flying Furniture" highlighting the parallels between the ideas that gave rise to the Golden Lane project (1952) and those shown on the Lattice Furniture stand at the Cologne International Furniture Fair (1999).

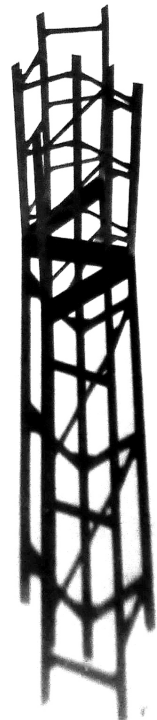
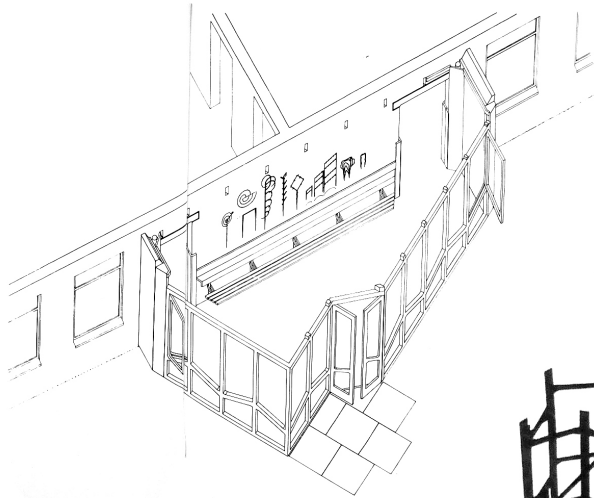
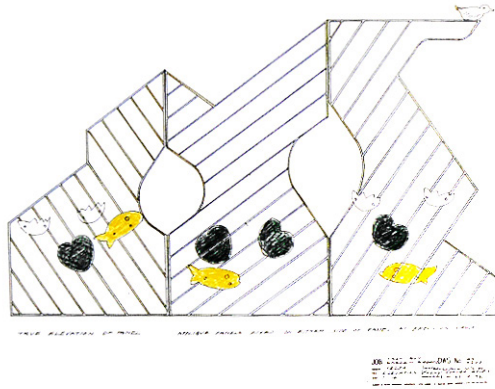
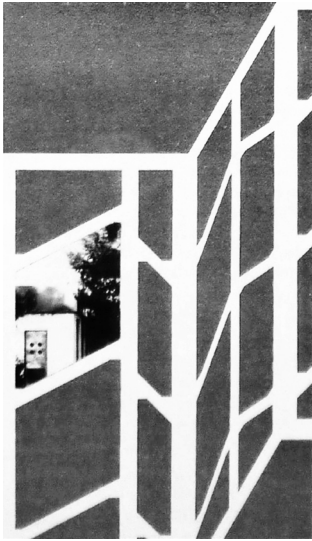

113 Flat-top lattice paravent with Prouvé door seen through a segment. Peter Smithson, 1997.

114 Waterlily/Fish Garden Screen. Alison Smithson, 1992.
The design is very similar to the one exhibited at the Triangle Arts Workshop (1987) but with the addition of latticework and appliqués.

115 'Tree-screen' at Triangle Arts Workshop, Pine Plains, New York State, 1987.

116 The Weaving Room Porch, Lauenförde. Peter Smithson, 1997.
Alison Smithson's 1987 designs for plant frames can also be seen on the walls.

117 TECTA invitation to imm Cologne, 1999. Miniature, broken-top lattice paravent and its shadow in the afternoon sun. Peter Smithson, January 1999.



118 View through the built trees from inside Axel's porch.
Alison Smithson, April 1988.

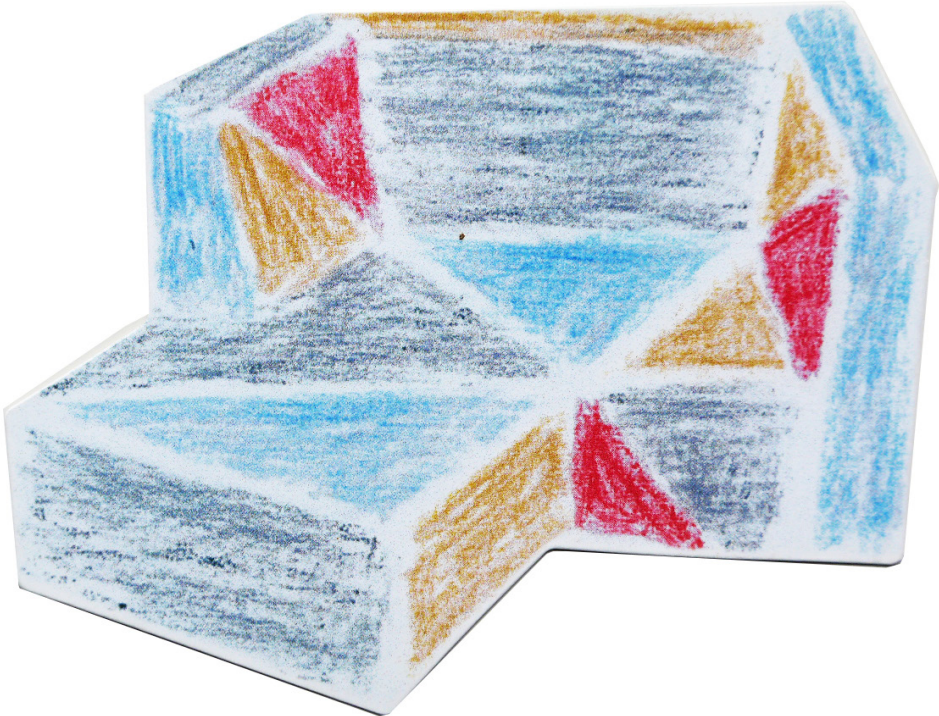

119 and 120 TECTA's invitation to imm Cologne. Peter Smithson, 2000.

Popova's Chair Exhibition Cologne International Furniture Fair (imm Cologne)

Peter Smithson

2000

Event, venue and dates: imm Cologne. Kölnmesse, Cologne. January 17-23, 2000.

Organizers: TECTA

Design: Peter Smithson

Work team: -

Gross floor area: -

Itinerary: -

Exhibition catalogue: -

Related publications: Peter Smithson and Karl Unglaub, *Flying Furniture: Unsere Architektur Rollt, Schwimmt, Fliegt = Our Architecture Rolls, Swims, Flies* (Cologne: König, 1999)

Additional information: Popova's lattice chair invitation. Peter Smithson

Reviews: -

The 2000 International Furniture Fair of Cologne was the last time that TECTA exhibited any furniture designed by the Smithsons. The item in question was Popova's Lattice Chair (1999), an armchair that completed the lattice furniture series shown in Cologne the year before on TECTA's Lattice Furniture stand.

Popova's Lattice Chair embodies the tribute to Liubov Popova first conveyed in both formal and conceptual terms by the Lattice Chair and Sofa. The outcome is an armchair that combines the branching lattice concepts and marks the end of the lattice furniture series, and which could also be seen as the last link in the Trundling Turk series begun in 1953.

The format of this particular piece, the Trundling Turk III, has a substantial history: it began in the fifties as a student chair, low, and looking as if it was capable of moving from room to room or out into the open. This format was carried – as Trundling Turk II – into different materials, bent plywood in the seventies and eighties and laser-cut, stainless-steel sheet in the nineties.¹⁰⁹

In 1998, Peter Smithson referred to the Lattice Chair (1998) as Trundling Turk III. However, the characteristics of Popova's Lattice Chair (low, on castors, asymmetrical, without the straightjacket of right angles, multipurpose, adaptable seating), meant it could easily have been the fourth member of the Trundling Turk series or even have replaced the Lattice Chair as Trundling Turk III.

Popova's Chair was the main feature of the TECTA stand at the Cologne fair and also of the invitation to this fair. The volume of its two-dimensional outline was suggested by a several strips of colour fanned out like the costume of Popova's 'Actor no. 7'. Peter Smithson stopped using the series of metallic-coloured invitations begun in the 1992 fair and designed a multicoloured object in a colour range that once again resembled those used in avant-garde art: yellow, black, red and blue: the same colours chosen for the first Trundling Turk in 1953.

The Cologne Fair of 2000 was once again the venue chosen to launch a book co-authored by the Smithsons and TECTA: *Flying Furniture: Unsere Architektur Rollt, Schwimmt, Fliegt = Our Architecture Rolls, Swims, Flies* by Peter Smithson and Karl Unglaub (published by Axel Bruchhäuser). This book takes a look at the concepts and work of the foremost modernist architects whose furniture designs were manufactured by TECTA.

109 Smithson and Unglaub. p. 46.



121 Peter Smithson sitting on Popova's Lattice Chair as shown in TECTA's 2010 Flying Furniture Catalogue.

122 Popova's Lattice Chair at imm Cologne, 2000.

123 Colour study of Popova's Lattice Chair. Peter Smithson, 1999.

124 Popova's Lattice Chair. Peter Smithson and TECTA, 1999.

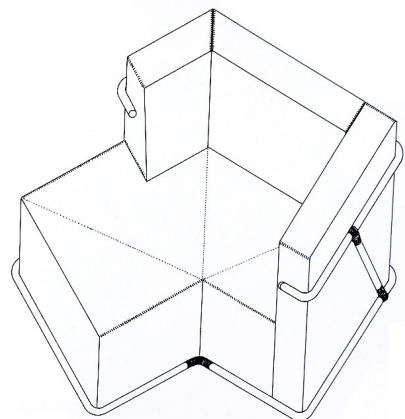
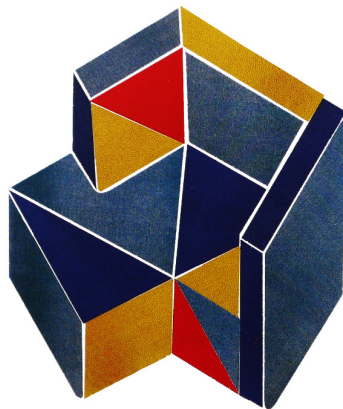

STUHLMUSEUM BURG BEVERUNGEN

Ausstellung

„FLYING FURNITURE“

vom 29.01.2000 – 30.04.2000

Mi – Fr : 15.00 – 17.00 Uhr

Sa : 10.00 – 12.00 Uhr

Eröffnung am 29.01.2000, 10.00 Uhr
durch Peter Smithson, London

Zur Ausstellung erscheint ein Katalog.

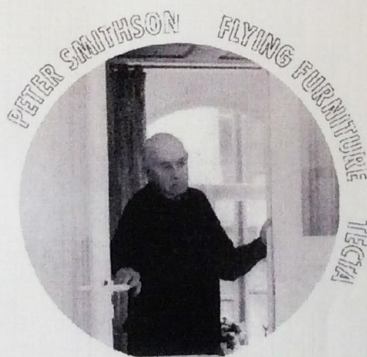

Kees Stoop, Amsterdam

Beirat: J.-M. Breiden, Köln, Seb. Niebler, München, A. & P. Smithson, London, Dr. W. Herzogenrath, Köln, Axel Bruchhäuser, Bad Karlshafen
D-3471 Lauenförde, Postfach 6, Tel. 05273/7006, Telefax 05273/8410, Volksbank Höxter-Beverungen Kto.-Nr. 105 000 000 (BLZ 472624 06)

KRAGSTUHL - SAMMLUNG & JEAN - PROUVE - ARCHIV

Flying Furniture

Peter Smithson

2000

Venue and dates: StuhlMuseum Burg Beverungen. January 29-April 30, 2000.

Organizers: TECTA (Axel Bruchhäuser)

Design: Peter Smithson

Work team: -

Gross floor area: -

Itinerary: -

Exhibition catalogue: Peter Smithson and Karl Unglaub, *Flying Furniture: Unsere Architektur Rollt, Schwimmt, Fliegt = Our Architecture Rolls, Swims, Flies* (Cologne: König, 1999)

Related publications: -

Additional information: -

Reviews: -

The 'Flying Furniture' exhibition held a few days after the end of the International Furniture Fair in Cologne was the last exhibition arising from the Smithson - ТЕСТА partnership. The exhibition happened at the same time as the publication of the book *Flying Furniture. Our Architecture Rolls, Swims, Flies*, and was, in fact, a sort of summary of this book. The original and identical reproductions showcased at the exhibition gave a first-hand insight into the evolution of the furniture covered by the book.

The venue chosen for this exhibition was the StuhlMuseum (chair museum) in Beverungen, a medieval customs tower rented by Axel Bruchhäuser to house his collection of chairs and the Jean Prouvé Archive, until the Kragstuhlmuseum (cantilever chair museum) designed by Peter Smithson was built in Lauenförde in 2003. The display was very simple because its sole purpose was to illustrate the concepts in the book – the real star of the show.

Flying Furniture. Our Architecture Rolls, Swims, Flies is very similar to *1972-1982 Bericht Einer Deutschen Unternehmung (Report on a German Company)*, a book published by ТЕСТА in 1983 in which Stefan Wewerka documented the work of both ТЕСТА and the architects whose designs were manufactured by ТЕСТА.¹¹⁰ *Flying Furniture* sets forth not only the designs but also the underlying ideas, and the designers' concepts were also often accompanied by the Smithsons' thoughts and interpretations of these designs and ideas. Some of the writings by the Smithsons were compilations of fragments of earlier essays whilst others were new articles written specially for the publication.

The book outlines the work carried out by several people in conjunction with Axel Bruchhäuser: Stefan Wewerka, described as a 'gifted deformer of the ordinary'; El Lissitzky, 'the draftsman of a future'; Jean Prouvé, 'the constructor and master of sheet-steel performing'; Marcel Breuer, 'the realizer of the potential of the steel tube'; Walter Gropius, 'the definer of rôles'; Ludwig Mies van der Rohe, 'the matchless master'; Gerrit Rietveld, 'the maker of things – sometimes magical things'; and the Smithsons themselves, described as 'poets of lattices and built fabrics.'

The title of the book is also a combination of the Smithsons' ideas and those of their beloved avant-garde masters. It is based on furniture flying around the building full of character and independence shown in Alison's thought-provoking drawing of the Lutzöwstrasse housing project.¹¹¹ Peter Smithson also referred to the series of cantilevered chairs produced by ТЕСТА as flying furniture because it was the 'image of an inner structure that is clearly visible as an "engineering impulse"'.¹¹²

110 Wewerka.

The book documents the work of Walter Gropius, El Lissitzky, Marcel Breuer, Peter Keler, Erich Brendel, Jean Prouvé, Alison and Peter Smithson, Piet Mondrian, Helene Jungnick, Aagaard Andersen and Stefan Wewerka.

111 Peter Smithson drew attention to it in 1999, possibly in order to explain the title of the book:

'In 1987, it would seem, Alison Smithson perceived that root-off drawing she had made earlier for the housing along the Lutzöwstrasse in Berlin could be seen as a beehive opened up with all our furniture flying around like disturbed bees.' Smithson and Unglaub, p. 28.

112 Peter Smithson: 'Evolution of tube aplati' for the Prouvé exhibition in MOMA, New York 2008/2009 reprinted in Marta Herford GmbH, ed., *Der Entfesselte Blick / The Unfettered Gaze. The Rasch Brothers and Their Influence on*

The book also has a sub-title, 'Our Architecture Rolls, Swims, Flies', which is an excerpt of a 1929 quotation by El Lissitzky: 'The static architecture of the Egyptian pyramids has been overcome: our architecture rolls, swims, flies. It will sway and float in the air. I want to help to invent and form this new reality.'¹¹³

The book is, in fact, a tribute to the modernism so admired by the Smithsons and the TECTA founder, Axel Bruchhäuser. Axel was 'an enthusiast of Bauhaus design, and the two polemical architects, sacrilegious interpreters of the same school'¹¹⁴ – an enthusiasm shared and fuelled since the beginning of their collaboration in the early 1980s as mentioned on the last page of the book. This page also features a photo dated 1985 of the meeting at Lauenförde between the Smithsons, Bruchhäuser and Stefan Wewerka (the person who thought it would be a good idea for the others to meet each other and was responsible for putting them in touch), alongside the following note signed by Peter Smithson:

From this beginning came – step by step – the reflections on the masters of the twenties and thirties set down in this book... reflections made possible by our work together since then in their spirit.

The Modern Movement is not a legacy in the sense of a sum of money to be spent or speculated with...it is a genetic stance, a responsibility...something to live up to.¹¹⁵

The concept of the book and exhibition was the work of Axel Bruchhäuser, the book's layout was by Karl Unglaub, and Peter Smithson wrote the texts. Once again, he was the speaker and presenter making sense of everything happening there. He was the ringmaster of this tribute just as he was at the 'Tischleindeckdich a.s.o.' exhibition in 1993. This is perhaps why the photo on the exhibition poster is, as Axel Bruchhäuser said, of "ring master" Peter Smithson at the Mautsch gallery in Cologne during the Tischleindeckdich exhibition in 1993. [...] It shows the continuity of their exhibitions with TECTA like a circus, as demanded by Peter in his opening speech in Berlin at Aedes.¹¹⁶

Modern Architecture (Tübingen: Ernst Wasmuth Verlag), p. 132.

113 Smithson and Unglaub, p. 97.

114 Scimemi.

115 Smithson and Unglaub, p. 191.

116 Axel Bruchhäuser (2015, May 10) [email to the author]. The photo of Peter Smithson was also published in Ute Reeh's book, *Reise* (Cologne: Ed. Hundertmark, 1999).



126 General view of the layout of the Flying Furniture exhibition at the StuhlMuseum Burg Beverungen, 2000.

127 Meeting at ТЕСТА in Lauenförde, 1985. From left to right: Axel Bruchhäuser, Stefan Wewerka, Peter Smithson and Alison Smithson.

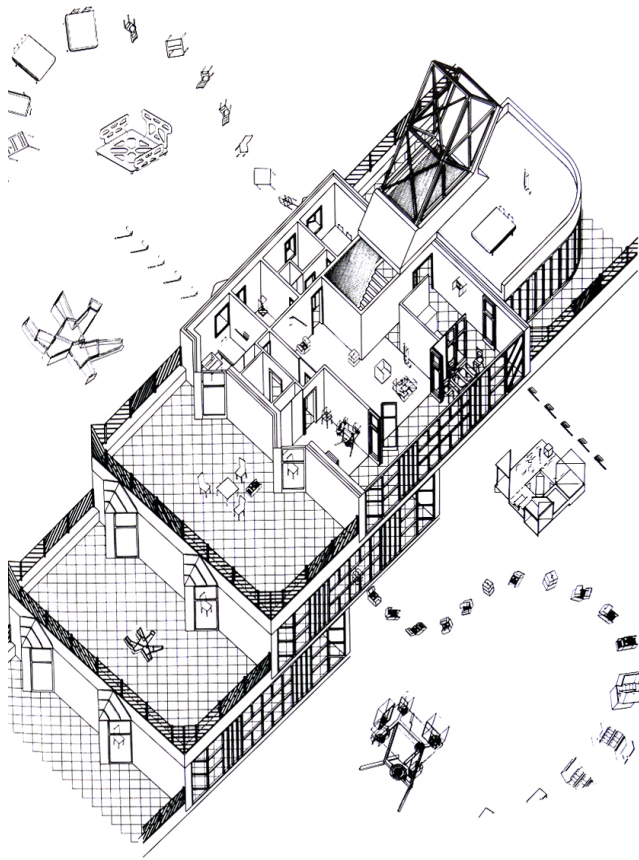

128 Lutzowstarsse Housing with Alison and Peter Smithson's furniture flying around like disturbed bees. Alison Smithson, 1987.

129 New version of Alison's drawing of the TECTA factory with the designs manufactured there fluttering around. Peter Smithson, 2000.

130 Change-of-address card depicting 16 different designs of chair on the move, 1961.





131 Photograph of Peter Smithson at the Mautsch gallery during the Tischleindeckdich exhibition, 1993.

Chair, house, city or society are 'organs of the inhabitants'.

Charlotte Perriand

There is no basic difference between the building of furniture and the building of a house.

Jean Prouvé

Of all pieces of furniture, the chair is the most able to carry like some portable shrine, the essence of the style of its period.

People rarely collect cupboards or dressing tables or stools, but to collect chairs is common: it is probably that we see them as domestic pets... they have legs, feet, arms; they are symmetrical in one direction; like animals; like ourselves.

The act of making territory starts with our clothes... with their styles, with our gestures and postures when we wear them. With a chair we extend the sense of territory beyond our skin.

With a chair we first impose ourselves on blind space.

It could be said that when we design a chair we make a society and a city in the small.

Certainly this has never been more obvious than in this century. 'One has... a perfectly clear notion of the sort of city and the sort of society envisaged by Mies van der Rohe, even though he has never said much about it. It is no exaggeration to say that the Miesian city is implicit in the Mies chair.'

Peter Smithson¹¹⁷

The above quotations from the book *Der Kragstuhl / The Cantilever Chair* published by Axel Bruchhäuser in 1986 all agree that the chair is more than 'a separate seat for one person' – the first definition of chair in the Oxford Dictionary. The 'chair' comes from the Latin 'cathedra' and Greek 'kathedra' which are also the root of the word 'cathedral', i.e. a church containing the bishop's throne (chair). Hence a chair is also 'a professorship' and 'the person in charge of a meeting or of an organisation' because the chair is related to authority, power and the possibility of establishing a personal stance for facing the world.

This nature of chairs and the opportunities they offer may explain perhaps why they were the forerunners of the changes sweeping through the world of design in the twentieth century. In 1917, Rietveld's Red and Blue Chair with its multi-coloured

117 'The Chair' written on 20 November 1985 by Peter Smithson for the Stuhlmuseum (TECTA's chair museum), Burg Beverungen (Axel Bruchhäuser, *Der Kragstuhl / The Cantilever Chair* (Berlin: Alexander Verlag, 1986), p. 86). The last part of the quotation is from another time, from an essay penned for a Le Corbusier exhibition in 1959. Alison Smithson, ed., *Team 10 Primer* (Cambridge: MIT Press, 1968), p. 34.

lines and blocks embodied by planks and sticks revolutionised the world of design with a 'much "purer" design (in Mondrian's own sense) than Mondrian's work at that time' as Peter Smithson pointed out in 1956.¹¹⁸ This language was explored first by Rietveld in a chair design and subsequently translated into the architecture of the Schröder-Schröder House in 1923.

Likewise, the mystique about the machine aesthetic in the 1920s – the forerunner of modern architecture – first materialised as experimental furnishings and fittings. One clear example of its importance was the series of furniture designed by Le Corbusier and Charlotte Perriand for the 1929 Salon d'Automne. On the assumption that all humanity has the same needs, they launched *casiers standard*, modular, stackable container units featuring a uniform casing intended to cater for completely different household requirements: several modular tables that could be grouped together, and various designs of chairs, each for a different need or purpose. This series included the LC7 swivel chair, the famous LC4 chaise longue, and its counterpoint lightweight and compact LC1 chair. In short, storage cabinets and a collection of glass and metal tables and chairs that embraced the machine and replaced 'countless, ridiculous pieces of furniture in different shapes and sizes'.¹¹⁹ A new concept of furniture based on functionality, economy, organisation, repetition, precision and standardisation, a concept so revolutionary that a new term had to be coined for it: *équipement de la maison* (household fittings). But as Alison Smithson said, 'it was not really "anonymous equipment", but furniture as in any other period. It was in the same aesthetic and carried the same idea as architecture.'¹²⁰

Parallels with Marcel Breuer's tubular-steel experiments and the Wassily chair (1925) at the beginning of his career come to mind, and with Mies van der Rohe's MR chair (1927) too. Both of these designs were part of an exhibition, the acclaimed 1930 exhibition of the German Werkbund in Paris, illustrating the principles of mass production in architecture and showcasing the avant-garde architecture to come. As regards chairs being the forerunners of the shift in design in the twentieth century, the Eameses' work after World War II must not be overlooked because much of it was devoted to chair design and also because they were always a benchmark for the Smithsons.

In the 1950s the whole design climate was permanently changed by the work of Charles and Ray Eames. By a few chairs and a house. [...]

The Eames moved design away from the machine aesthetic and bicycle technology, on which it had lived since the 1920s, into the world of the cinema-eye and the technology of production aircraft; from the world of the painters into the world of the layout-men.¹²¹

The Eameses were natural consumers of the available technologies which they applied to their furniture design with the aim of implementing their main design strategy:

118 Alison Smithson and Peter Smithson, *The Heroic Period of Modern Architecture* (Milan: Rizzoli, 1981).

119 LeCorbusier and Pierre Jeanneret, *Le Corbusier - Oeuvre Complète: 1910-1929 Vol 1*, ed. by Willy Boesiger and Max Bill (Les Editions d'architecture, 1966). Our translation.

120 Alison Smithson, 'The Future of Furniture', *Architectural Design*, April (1958), 175-78.

121 Peter Smithson, 'Just a Few Chairs and a House: An Essay on the Eames-Aesthetic', *Architectural Design*, September (1966), 443-46.

'make the best for the most for the least.' One example of this was their first fibre-glass chair prototype entered for the 'Low Cost Furniture Competition' held by the MOMA in 1948. As soon as the polyester plastic reinforced with fibre-glass developed by the US Air Force during the war became available, they began to incorporate it into their furniture design. Likewise, they applied the same work ethic to their concept of the home.

We are concerned with the house as a basic instrument for living within our own time; the house as a solution of human need for shelter that is structurally contemporary; the house that above all takes advantage of the best engineering techniques of our highly industrialized civilization.¹²²

The lightness of their chairs, a flicker of change after the war, sent tremors through the world of design on both sides of the Atlantic. But the new mindset was not only physical – the main change happened with the acknowledgement of the intrinsic character of the chair as regards the space in which it was located. Peter Smithson drew attention to the fact that 'Eames chairs are the first chairs which can be put into any position in an empty room. They look as if they had alighted there – that crow in the wire chair photograph is no coincidence. The chairs belong to the occupants not to the building.'¹²³

But the chairs of the first modern era were to a great extent associated with their buildings. 'Mies chairs are especially of the building and not of the occupants.'¹²⁴ the Barcelona Chair, the Tugendhat Chair, the Brno Chair, etc. In addition, their geometry, dimensions and design made it difficult to dissociate them from the building containing them. This was because, like the *casiers standard*, the furniture of the 1920s was not designed to add its own 'architecture' to an already existing architecture but to define that architecture itself: it was part of the composition and definition of space.

Transitions and transformations

In the quotation at the beginning of this essay, Peter Smithson associated chairs with considerations closely linked to their way of thinking: the style of a period, collections, pets, territory, city, society and history. The relationship between these considerations and chairs did not happen suddenly in the 1980s – in a way they were already present in the 1950s when the famous photograph of the Smithsons was taken on Limerston Street together with Nigel Henderson and Eduardo Paolozzi. This photograph appeared in the *This is Tomorrow* exhibition catalogue and showed the four members of Group 6 sitting in the middle of a street as if it were their living room. A simple gesture that nevertheless implied quite an allegory and declaration of intent as regards their concept of the house, the street and the city but also as regards the role of furniture, inhabitation, territory, mobility, lifestyle etc., in which chairs (and their statement possibilities) were once again the leading lights. The members of Group 6 are accompanied in this photo by a traditional, high wooden stool, the

122 Charles Eames, 'What is a House?' (1944) in John Neuhart and Marilyn Neuhart, eds., *Eames Design: The Work of the Office of Charles and Ray Eames* (New York: Abrams Books, 1989), p. 46.

123 Peter Smithson, 'Just a Few Chairs and a House: An Essay on the Eames-Aesthetic.'

124 Ibid.

Eames Wire Chair and Plastic Armchair, and a cantilevered chair by Marcel Breuer: four types of seating, four persons and four ways of sitting (or adopting a stance) to face the camera and the world.

Alison and Peter Smithson did not only design furniture with ТЕСТА in the 1980s and 90s. In the 1950s at the beginning of their career they also experimented with furniture, aware from the start of the possibilities inherent in producing them. Firstly with the Jenkins' Cabinet (1952) and the Trundling Turk (1953), and then in the sketches of tables made of marble slabs from fireplace surrounds on Limerston Street (1955), the Light Stick lamp which attempted 'to domesticate the fluorescent light'(1958), etc.¹²⁵ However, none of these early designs advanced beyond the prototype stage.

The 'House of the Future' built at the 1956 Ideal Homes Exhibition was an opportunity to bring some of these early concepts to fruition. Appliance cubicles appeared, storage built into the actual structure of the house to hold all household appliances whilst creating a seamless outer shell that defined areas and functions, 'so that we do not have efficient "rooms" but a total shift away from the "room" fixation.'¹²⁶ These cubicles were the common denominator in the Appliance Houses series that comprised the Smithsons' research into suburban housing in the 1950s, the general aim of which was 'to regain as much as possible of the house as usable space.'¹²⁷

Inside this continuous outer shell, the only independent items were chairs – also designed specially for the House of the Future by Alison Smithson. They included the Pogo Chair, an extension of the family of tubular-metal chairs from the heroic period, whereas 'the remaining chairs are moulded and thus share the characteristics of the doubly curved modelling of the house itself'.¹²⁸ This second group of chairs made entirely from plastic consisted of the Egg, Tulip and Saddle Chair.

In 1961, Alison created a change-of-address card showing several chairs moving from their office on Limerston Street to their new home on Priory Walk. In addition to these new designs by the Smithsons, the card also features the collection of seats photographed on the street with Henderson and Paolozzi in 1956 (fig.130). A group of chairs in motion that heralded in a shift in attitude to furniture and architecture.

Bracketing the first period of our furniture are the notices of Removal, Doughty Street to Limerston Street, late summer 1953 (post the tenth Congress of CIAM, Aix-en-Provence); and Limerston Street to Priory Walk, summer 1962. From the first drawing of the Jeep's shape, as if a people-tray on the move, to the drawings of our chair collection as a family of easily moveable frames on the move, had occurred a shift in our attitudes towards furniture.¹²⁹

125 Alison Smithson and Peter Smithson, *Alison + Peter Smithson: The Shift*, ed. by David Dunster, Architectural Monographs no.7 (London: Academy Editions, 1982). p.26.

126 This is the basis of the 'Appliance Houses'. Alison Smithson, 'The Future of Furniture'.

127 Peter Smithson and Alison Smithson, 'The Appliance House', *Architectural Design*, April (1958), 177.

128 Alison Smithson and Peter Smithson, *The Charged Void: Architecture* (New York: Monacelli Press, 2001). p.174.

129 Alison Smithson and Smithson, *Alison + Peter Smithson: The Shift*, p. 28.

This new mindset began to become obvious in the 1970s when the Smithsons became active in furniture design again and took part in two competitions: the Interdesign 2000 Furniture Competition of 1972 (together with Ronald T. Simpson) and the San Diego Chair Competition of 1976 for which they entered that 'soft-cornered remembrance' of the Trundling Turk.

Their previous experience of furnishing the 'House of the Future' made them realize that 'no one should suffer by bumping into any piece of furniture (furniture of the 'fifties was lethal to toddlers') and that 'a person must be able to pick up a casual chair in one hand to move it closer for conversation, for work, or dining'.¹³⁰ These two basic, unavoidable traits were incorporated into the series of furniture entered for the 1972 competition which was characterised mainly as being 'domestable', 'movable' and 'dressable'. Domestable because the focal point was always the home and the aim was to encourage the free and veritable expression of the art of inhabitation. Movable, a characteristic already suggested on the change-of-address card that shifts the urban mobility concepts developed by the Smithsons in the 1950s into the home interior.¹³¹ Dressable like the architecture based on layers and layering that they were exploring in parallel at that time.¹³²

The basic premise of the series of furniture entered for the Interdesign 2000 competition was that home furnishings have different requirements: non-display, display and furniture.

Increasingly, the pattern of inhabitation seems to suggest that non-display storage (clothes, tools, leisure equipment, food) will be taken care of in the design of buildings. Display surfaces tend to be the 'adaption element', that special 'tailored' addition that connects inhabitator to the place he chooses to inhabit. 'Furniture' therefore, in houses and workplaces, will be those very personal things which people will take around with them and perhaps renew often, in response to fashion: CHAIRS.... TABLES.... BEDS.... LIGHTS.¹³³

They proposed designs for the last group, the items considered to be actual furniture and which pursued the same idea of interplay between the permanent and the movable: 'the theme of all furniture pieces of this series is the interplay between the (permanent) frame and the (changeable) skin.'¹³⁴

All the furniture in that series consisted of supporting (permanent) frames made from plastic (acetal copolymer) with small cross sections to minimise their dirt-collecting surfaces and reduce their weight. This was particularly important

130 Ibid, p. 44.

131 In 1958 they wrote the essay 'Mobility: Road Systems' (Alison Smithson and Peter Smithson, *Architectural Design*, October (1958), 385-88) and illustrated it with the diagram 'Play Brubeck'. 'Mobility is the key both socially and organizationally to town planning, for mobility is not only concerned with roads, but with the whole concept of a mobile, fragmented community.' Mobility is related to the community and human associations in the same way that movable furniture ensures the creation of social relations between its users.

132 The Interdesign 2000 competition (1972) took place between the construction of Saint Hilda's College (1967-1970) and the Lucas Headquarters project (1973-1974).

133 This quotation mentions matters that were addressed subsequently in their later 1970 housing designs such as the Yellow House (1976) and the House with two Gentries (1977). Alison Smithson, Peter Smithson and Ronald T. Simpson, 'Family of Furniture. Interdesign 2000 Furniture Competition', 1972.

134 Smithson, Smithson and Simpson.

for 'all-purpose chairs' because 'all "sociable" chairs must be light enough to be picked up easily with one (adult) hand and moved closer to, or to a better, social alignment'.¹³⁵

The 'skin' or disposable part that could 'be regarded as the "decoration" of the furniture'¹³⁶, on the other hand, could easily be changed to cater for the preferences of different users or for a single user who simply decides to redecorate. The 'skin' was a membrane made of polypropylene and polyester fibres combined with polyurethane. Hence the entire series was made of plastic and could 'be used indoors and out under almost any climatic condition'.¹³⁷

Tables and beds and particularly chairs emerged in the early 1970s as a vehicle for renewing indoor and outdoor decoration but also as the beginning of the parallel renewal of their own mindset. Many characteristics of the series of furniture entered for the Interdesign 2000 competition gradually migrated to their architectural concepts in that decade and then materialised in the Christmas exhibitions outlined in the previous chapter. This experience was obviously incorporated into their furniture too when they began designing furniture again after starting work with TECTA in the 1980s.

The Car, the Bird and the Tree

Furniture is an inseparable part of architecture and the art of inhabitation that embodies the feelings of each era. Looking back once again to the beginning of the twentieth century, the evolution of furniture can be traced through each of the three generations of modernism identified in the Smithsons' essay published in the 1980 ILA&UD Yearbook.

The First Generation was the fresh beginning in the nineteen twenties when 'Purism, Bauhaus and de Stijl had their solid pieces of house equipment defining the spaces to which their light mobile furniture was related'.¹³⁸ At that time, the machine as an ideal shifted to the standardised architecture and city of *casiers standard*, as regards not only the precision emanated by their geometry and quantity, but also the functional streamlining of mass-produced items. Furniture, then regarded not as decoration but as equipment, defined space and architecture to achieve 'the simple life, well done' that Alison compared with Beatrix Potter's interiors.

In Beatrix Potter's interiors, objects and utensils in daily use are conveniently located, often on individual hooks or nails, and are all the 'decoration' the 'simple' spaces need, or in fact can take. Those things in secondary use or needing long term storage are in special storage cubicles whose forms define the house space proper – as well as being pleasant spaces in themselves. Here then, we find basic necessities raised to a poetic level: the simple life, well done.¹³⁹

135 Ibid.

136 Ibid.

137 Ibid.

138 Alison Smithson, 'The Future of Furniture'.

139 Alison Smithson, 'Beatrix Potter's Places', *Architectural Design*, December (1967), 573.

However, the third-generation architects Alison and Peter Smithson, with their appliance house proposals shifted the focus of this concept towards the spatial organisation of the Japanese home in which storage is unobvious to spaces and yet defines them.

At that time, in the late 1950s, the myth of the machine had been overcome and what really concerned the Smithsons was the changes that the overwhelming increase in the number of machines, i.e. household appliances, could cause in the sphere of housing. 'A good many people are interested in technology, but far fewer are interested in the changes it can bring to the way of life and shape of things.'¹⁴⁰

The Appliance House was an attempt to solve the problem of 'a move away from furniture-appliance chaos towards a put-away house'.¹⁴¹ The storage space built facing in on itself silently defines space by dissociating itself from the living area that stands empty for the theatre of everyday life and flowing freely between the volumes constructed in this way. An architecture of 'concealment and display'.

The shell of the cubicle forms the permanent structure defining the space, whilst the inside can be stripped-out and re-equipped when owner's or fashion's changing needs and methods demand.¹⁴²

In short, an architecture and furniture that seek to build a neutral framework 'without rhetoric' which ensures the necessary privacy and protection whilst waiting to be appropriated by users, and also ensures the void that provides a space for humanity.

An intermediate generation – the Second Generation – made a great contribution to this definition of space in the home by incorporating the machine for the common good. The Eameses incorporated technology into design naturally in order to use industry to reach as many people as possible whilst always upholding the object integrity that made it possible to enhance each item in the group and make them independent. In addition, the 'select and arrange' technique used in their compositions – a basic element which the Smithsons called the 'Eames Aesthetic' – was based precisely on this object integrity, acknowledging their peculiarity. 'It uses things for what they are, each object being enhanced and speaking more clearly of itself in virtue of the "arrangement"'.¹⁴³

By transposing these ideas to furniture, it was also possible to dissociate chairs from their surrounding architecture, thereby reinstating their integrity and making them (the chairs and therefore their users) share the limelight. 'They can be photographed as a fragment, they can be enjoyed as a fragment. They have high

140 Design, May 1958 (Alison Smithson, *Team 10 Primer*, p. 11).

141 Alison Smithson, 'The Future of Furniture'.

The put-away house (1993-2000) was a much later design in which Peter Smithson addressed the subject of superabundance. There is an obvious connection between the two and, therefore, between the two periods. For an in-depth analysis by Peter Smithson about the house, see Catherine Spellman and Karl Unglaub, eds., *Peter Smithson: Conversations with Students* (Princeton Architectural Press, 2005).

142 Ibid.

143 Alison Smithson and Peter Smithson, 'Concealment and Display: Meditations on Braun', *Architectural Design*, July (1966), 362-63.

object-integrity.¹⁴⁴

Those three specific periods described by the Smithsons as the Three Generations are part of a single branch of modernism which the Smithsons considered themselves to be descendants of. The three approaches of these generations are perfectly illustrated in the 1982 collage by Lorenzo Wong and Alison Smithson,¹⁴⁵ which explains the iterative process of the diagonal structure brace being transformed into lattices with entirely new meanings through the work of the Three Generations. But what is particularly revealing about the collage, is the inhabitants of each fragment. The first generation is represented by a car in Mies van der Rohe's House on a Hillside (1934); the second by a bird between the legs of Charles and Ray Eameses' Wire Chair (1952); and the third by a tree linking the structure of the Lucas Headquarters (1973) to its surrounding landscape. In other words, firstly, a car (a machine) 'announces the Esprit Nouveau' marking a new beginning; in a second phase of assimilation a bird lands between the chairs and recovers the individuality needed 'to embrace the machine'; and in the third generation, a tree symbolises the need for architecture to be specific to a place in order 'to engage with the existing urban fabric', i.e. its necessary contextualisation.

Finally in the 1980s, the decade when the Smithsons started working with ТЕСТА, another new phase began for the Smithsons which they referred to in 1985 as the Fourth Generation, yet another branch of the modernist movement which they had defined.¹⁴⁶ In just five years they became aware of a new mindset that was to give rise to a new form of architecture. Meeting up again with Stefan Wewerka obviously played an important part in this change of outlook, but their introduction to Axel Bruchhäuser and the start of their collaboration with ТЕСТА even more so. A final period of their work which gradually advanced towards what they themselves called the architecture of 'conglomerate ordering'.

It was the article 'On the Edge' that mentioned for the first time this all-encompassing concept that describes architecture not by means of images, materials, objects or geometric diagrams but by the experiences and sensations generated by its spatial presence because 'conglomerate ordering harnesses all the senses'.¹⁴⁷

144 Peter Smithson, 'Just a Few Chairs and a House: An Essay on the Eames-Aesthetic'.

145 This collage was made after the collage by a Harvard student for Peter Smithson's lecture 'Three Generations' at the Graduate School of Design in 1980. Created after a telephone conversation in which Peter told the student about the content of the conference, the collage shows three overlapping floor plans of three renaissance churches – one for each generation. This draws parallels between two historical moments that marked a new starting point for architecture. See Smithson, Peter, *Two Drawings of Three Generations*, 1982. (Drawings), Harvard Design School, Frances Loeb Library, Special Collections Department, The Alison and Peter Smithson Archive: An Inventory.

There are also two versions of this collage of the three modernist generations: one by Peter in which the Eames chairs are outlined by the ground line of the Miesian house, and one by Alison in which the legs of the Eames chairs are interwoven with the structure of the Lucas Headquarters. Peter Smithson, 'The Masque and the Exhibition: Stages Towards the Real', *ILASUD Yearbook 1981*, 62–67.

146 This new fourth generation arriving in the wake of the three previous generations, had already been mentioned in 'Some Lines of Inheritance', an essay based on the Harvard conference 'Three Generations' and revised in January 1985 prior to its publication in the book entitled *The 1930's*. Alison Smithson and Peter Smithson, *The 1930's* (Berlin: Alexander Verlag, 1985), p. 13.

147 Peter Smithson, 'On the Edge', *ILASUD Yearbook 1984*, 60–63.

The Smithsons became aware of the possibilities that this approach could have for architecture whilst studying the ancient Italian cities of Siena, Urbino and Venice during the annual ILA&UD workshops which Peter had attended since 1974, and also whilst working on the Bath University projects. This way of working was not, however, developed deliberately until their declaration of intent one year later in 1985, in the article 'Conglomerate Ordering' in which they said for the first time, 'we are now into the fourth generation'. A fourth generation focussing on the experience of the inhabitant in order 'to signal changes of use within the existing fabric' by means of new tools in the form of devices and decorations. The first manifesto of this whole revolution was the statement and furniture shown at the International Furniture Fair in Milan by Alison Smithson and ТЕСТА under the title: 'The Future of Furniture – The Furniture of the 4th Generation.'

The Female Line

Alison Smithson played a foremost part in all this new approach to their architecture because, until her death in 1993, she was in charge of the projects carried out in conjunction with Axel Bruchhäuser including the furniture, exhibitions and successive alterations to the furniture factory at Lauenförde and Bruchhäuser's own house, the Hexenhaus. Peter Smithson acknowledged in the same essay, 'Three Generations' (1980), how 'much of our inheritance reached us through the female line... Truss Schroeder-Schrader, Lily Reich, Charlotte Perriand, Ray Eames'.

For the invention of a new spacial container needs the separate invention of the objects and the decoration of the play of life within it. It needs the invention of those ways of walking and holding the head, of dressing, and of setting the table, and of putting down one's book – and all that these involve; and that has come from the female line.¹⁴⁸

Although she is not mentioned, Alison Smithson is obviously included in this female line.

Alison and Peter Smithson were always an indivisible, complementary team but as happened in their architecture, the sum or combined effort did not interfere with their individual character or identity. From the start of their career to the compilation of their own work in *The Charged Void* they were always careful to point out the contribution each one made to their projects, making it easier to determine their respective roles and individual interests in their legacy. Peter was always more involved with the studio's external relations, like a real ringmaster, whilst Alison remained in London, almost always writing. This might be because of certain gender issues which cannot be overlooked, particularly taking into account the professional and social context of that period.¹⁴⁹ Although neither of the Smithsons separated their work from their personal life – their work was in fact part of their lifestyle – certain details such as, for example, the photo of Alison on the patio at Upper Lawn

148 Peter Smithson, 'Three Generations', *ILA&UD Yearbook 1980*, 88–95 (p. 95).

149 Peter had more opportunities to travel and attend reunions and interviews and also gave classes at different universities almost constantly from the 1950s onwards: Architectural Association (1955–1960), Cornell University (1971), ILA&UD Workshop (1974–2000), Bartlett (1976–1977), Bath University (1978–1990), etc.

working at her desk with her daughter Soraya asleep beside her, and the location of her small office and archive at Cato Lodge on the threshold between their office and their house, half way between her work and family life, are very eloquent.

Alison Smithson was the last in the female line mentioned by Peter from the start of her career in the 1950s. She was always interested in the life conveyed by things ephemeral (Christmas cards, flags, decorations, exhibitions), traditions, fairy tales and also, in the same line, those concerning the play of life within, i.e. furniture. This attitude to the most human considerations was also obvious in her drawings. A look at the authorship of their drawings shows that it was often Alison who portrayed indoor life, including both its possible appropriations by users and the nature growing around it, just as they imagined it developing in the void created by the architectural framework they were designing and which was, in fact, the object of the drawing.¹⁵⁰

Most of their focus on furniture in the 1950s, as mentioned earlier, consisted of the series of Appliance Houses including the House of the Future designed entirely by Alison, and the essay 'The Future of Furniture' also by Alison. Likewise in the late 1970s, Alison was also in charge of the series of Christmas exhibitions, experiments with ephemeral architecture inspired by tradition in an attempt to try out an incipient renewal of their architecture. Subsequently in the 1980s, Alison was once again in charge of the Smithsons' partnership with ТЕСТА, which led to a completely new concept of furniture design and a new vision of exhibitions and, in short, a complete overhaul of their appreciation of architecture – so much so that when students at Arizona State University asked Peter Smithson in 2001 if Alison had left anything for him to finish, he was quite adamant:

Yes. That is, she established the language for the German work – the ТЕСТА Factory and the Axel Bruchhäuser house. It is a whole new mode – I know that puts it crudely. I've simply continued that. After fifteen years or so of continuing, I still have not exhausted that which Alison started.¹⁵¹

This is not, however, a straightforward matter because it is not easy to distinguish between the work of Alison and Peter.¹⁵² What is more, 'the difficult thing is explaining the reciprocal nature of Alison's and my talents [Peter]' because it is the outcome of a personal and professional life shared 'twenty-four hours a day. It becomes a question of looking and reflecting on the notions of the other.'¹⁵³

150 As was the case, amongst many instances, of the axonometrics of Saint Hilda's College, drawn by Christopher Woodward but to which Alison added figures, vehicles and hundreds of individual tiny leaves on the copper beech tree. (Christopher Woodward, 'Drawing the Smithsons', in *Alison & Peter Smithson: A Critical Anthology*, ed. by Max Risselada (Barcelona: Ediciones Polígrafa, 2011), pp. 258–67). It is also the case of the 'Strip of Family of "domestables" and "decorables"' drawing in which they showed how the furniture designs entered for the Interdesign 2000 competition could be appropriated (Harvard University, Graduate School of Design, Frances Loeb Library, Special Collections, The Alison and Peter Smithson Archive: An Inventory).

151 Peter Smithson, Catherine Spellman and Karl Unglaub, *Peter Smithson: Conversations with Students* (Princeton Architectural Press, 2005), p. 46.

152 Hence, by way of example, although it is obvious that the 'House of the Future' was designed entirely by Alison and its outer shell by Peter, in a portrayal of the traditional gender division, as Beatriz Colomina said, 'But it is not so easy to separate the house from the case, Alison from Peter'. Dirk van den Heuvel and Max Risselada, eds., *Alison and Peter Smithson - From the House of the Future to a House of Today* (Rotterdam: 010 Publishers, 2004), p.41.

153 Smithson, Spellman and Unglaub, p. 46.

Collections and Decorations

The first pieces of furniture designed in conjunction with ТЕСТА in the early 1980s were related to decoration and the new-found culture of the object and collecting: boxes for trinkets such as the His & Her Box, the Struwelpeter's Wallcabinet for displaying a personal collection of small objects on the wall, the Collector's Table which, despite its name, is not a table at all but a tribute to collecting, and so on. All these designs were a reflection of society's increasing interest in new ephemeral products: souvenirs of travel to foreign lands, everyday objects and antiques from Europe's own culture. Needless to say, as mentioned earlier, the Smithsons were great collectors.

The starting point of these early furniture designs was the 'concealment and display' concept searching once again for an ordering aesthetic able to free space from the new avalanche of accumulated items. This concept was based on an approach similar to the one applied previously to the Appliance Houses. Alison Smithson harked back to these ideas of the 1950 during the opening speech of the Wewerka pavilion in 1985 in which she summed up her approach to furniture on the basis of two essential articles: 'The Future of Furniture' (1958) and 'Concealment and Display' (1966). They had been in search of an orderly and somewhat anonymous style of architecture that could be applied to the Eames aesthetic based on the 'select and arrange' approach. Receptive furniture and architecture that could be the foundations for the art of inhabitation.

To create a large and, ideally, empty inhabitable space in which to house a personal expression of inhabitation, the opposite is needed, i.e. a place with plenty of room for storage. This concept first materialised in appliance cubicles, an attempt to deal with the increasing numbers of appliances that began to invade households in the 1950s, and became a permanent feature in housing design until the Put-Away House came on the scene in the early 1990s, in response to a new era characterised by glut.¹⁵⁴ This matter was not new, as Alison pointed out referring once again to history:

The Palladio villa outshone the warehouse that dominated the palaces belonging to Florentine merchants, the area of the house was enhanced by ridding itself of chaos: Palladio enlarged the warehouse and used it to connect up with and define the zone of the house's space.¹⁵⁵

The underlying concept of both the Appliance House and the Put-Away House was, in any case, to build a framework that enabled users to make use of space in different ways. The empty room was a stage for its user – always the real leading figure.

'...the space you make has to offer itself for the inventions of those who occupy it. In a way, what I am explaining is like a children's party. The mother organizes certain possibilities for play,

154 In 1958, in her essay 'The Future of Furniture' Alison had already written: 'The "Appliance House" is a move forward from a furniture-appliance chaos towards a put-away house.' Peter Smithson was working on the design of that put-away House (an heir of the 'Appliance House') from 1994 until 2000. For further information about the ideas that gave rise to that house, see Spellman and Unglaub.

155 Alison Smithson, 'Opening Lecture of the "10 Years of Stefan Wewerka in ТЕСТА, 1975-1985" Exhibition' (Lauenförde, Germany, 1985).

but whether the party goes well or not depends on the invention of the children. The mother is designing a framework.¹⁵⁶

In 1986, the stand at the Milan Furniture Fair was once again called 'The Future of Furniture' and, as in the 1958 essay of the same name, Alison tried to outline the characteristics of the furniture of the new era, the furniture of the Fourth Generation – hence the subtitle of the exhibition: 'The Furniture of the 4th Generation'. A shift in their efforts was obvious from that time onwards. The aim was no longer to build the framework or provide concealment, that silent architecture that defines a background, but to focus on the life taking place in that void, in the display.

'Where, we asked, are the parallel inventions; the new style of life and its furnishings, which could allow us to enjoy in a different way the sun, the seasons, the nature of the city, the sense of the horizon?'¹⁵⁷

Their next goal was to encourage the art of inhabitation and maximise the personal expression of the inhabitant by means of those devices and decorations intended to multiply the possibilities of interplay: to activate and not merely support the art of inhabitation.

The Waterlily/Fish Desk sprang from the same idea: it had space to store things in and space to enjoy, boxes to conceal and unclutter the desk top to make room for thinking. The Collector's Table with its small drawers, shelves and showcases was based on the same concept too, but in fact the focus of the two is different. They are shown as a framework waiting to be appropriated and which only makes sense once occupied by the user: a concept conveyed by both their shape and colour. Neither piece of furniture features the basic colours of the Heroic Period that the Smithsons used to upholster the Trundling Turk (black, blue, red and yellow), preferring a colour range that enabled them to blend in with their background whilst highlighting the objects they are to contain. The splatter-on-silver of the Collector's Table 'brings the lacquered surface to happily co-habit with natural woods, marbles and so on. In the Waterlily/Fish desk, the metallic lustre of the pedal base, the neutral, see-through writing surface, plays this co-habitation role.'¹⁵⁸ The boxes were coloured but could change colour without being dissociated from their language: waterlilies and fish.

As a result, all the furniture designed from then onwards featured these metallic tones in order to face the world like a silent framework, open to interpretation, giving full pride of place to the inhabitant. Only the upholstery of the Lattice Chair, Lattice Sofa and Popova's Lattice Chair featured a little colour: fleeting, replaceable and personalisable 'inhabitants' of the lattice that constituted their basic structure.

Materials were used in a similar way. Unlike in the 1950s when the main concern was 'the seeing of materials for what they were: the woodness of wood; the

156 Smithson, Spellman and Unglaub, p. 81.

157 Peter Smithson, 'Parallel Inventions', *ILAC&UD Yearbook 1982*, 46–51.

158 Marco Vidotto, *Alison + Peter Smithson. Obras Y Proyectos* (Barcelona: Ed. Gustavo Gili, 1997), p. 220.

sandness of sand',¹⁵⁹ Peter Smithson points out that 'he is not using material for self-expression, but for preparing the human expression, trying to get as close as possible to life.'¹⁶⁰

The main decoration is life itself, usage, the expression of its inhabitant conveyed by signs of inhabitation. Furniture becomes decoration by transforming itself into the underlying structure of this inhabitation: the Waterlily/Fish Desk is a device for thinking and the Collector's Table is scaffolding for the pleasure of contemplating all our jumble of belongings and, therefore, the most personal expression of the interests of its collector inhabitant. Furniture assumes a leading role that bears witness to its absent inhabitant and therefore appropriates itself of space and ceases to cling to walls.

Both pieces of furniture 'have come out of the same larder of objects as the 'intellectual food' that fed our 1950's generation; goodies which the Eames made into a banquet.'¹⁶¹ The Collector's Table was a celebration of collecting and a veritable tribute to the Eameses' 'select and arrange' technique. When completely covered in different objects, it looked just like the table in front of the sofa in the Eameses' house in Santa Monica. It brought the era of concealment boxes to a close and paved the way for the new series of display boxes: the Struwwelpeter's Cabinet (1986), irregularly shaped wall display units inspired by the unkempt hair of the main character in a story book by Heinrich Hofmann; the Jewel Box (1988) to display and organise everyday items; and the Cornell Boxes (1988), a tribute to the American artist Joseph Cornell who developed an entire universe of personal symbols through his boxes.

Joseph Cornell (1903-1972), an American artist, assembled his magical boxes as quiet passion. I have read that he saw them as 'never-finished'. Those boxes sold or given to others being "on loan", able to be recalled for adjustment or further refurbishment as the improving fragments or the shift of the dream came to him.¹⁶²

Life is the decoration of the private realm as shown as the decoration of the urban scene in the 'Wedding in the City' exhibition of 1968. Each thing is part 'of our everyday "invisible" decoration, [...] invisible because they change so slowly, because they are so normal.'¹⁶³ There is no distinction of scale in their thoughts or between the house and the city. As a result, the city subjects examined are reflected in the home too: the urban infrastructure permeates the home in the form of appliance cubicles, layers and lattices, whilst urban decoration or street life becomes the art of inhabitation. These two complementary approaches are found in the Smithsons' designs from the 1950s onwards. In 1956 to be precise, a marvellous year for the

159 David Robbins, *The Independent Group: Postwar Britain and the Aesthetics of Plenty* (MIT Press, 1990), p. 201.

160 Smithson, Spellman and Unglaub, p. 100.

161 Vidotto, p. 218.

162 Peter Smithson, January 2000 in *Alison & Peter Smithson: Flying Furniture (sales catalogue)* (Lauenförde: TECTA, 2010).

163 Alison Smithson and Peter Smithson, 'Triennale Di Milano: Transformations of the City', *Architectural Design*, April (1968), 151.

Smithsons in which they materialised many ideas, they produced the House of the Future and its appliance cubicles that define the void, and at the same time they emphasised decoration and the absent inhabitant in the Patio and Pavilion installation.

At first, at a time that coincided with the period they called the Third Generation, the emphasis shifted to the framework and its connection with the place. Subsequently, however, a parallel shift occurred in both the house and the city which increasingly acknowledged the inhabitant as being responsible for architectural renewal. This new focus was reflected in the Christmas exhibitions which gave rise to the shift addressed in the Smithsons' 1982 essay of the same name. It was the change in the mindset, maturity and sensitivity of their users and their growing skills in the art of inhabitation that enabled the shift towards the architecture of the Fourth Generation, the first examples of which were the furniture designed by Alison Smithson in conjunction with ТЕСТА and exhibited on the ТЕСТА stand at the 1986 Milan Furniture Fair.

Just as the Rietveld chair was the leading light that enabled the Schroeder-Schrader House to be built, so did the Waterlily/Fish Desk and the Collector's Table the laboratory foster the materialisation in 1986 of Alison Smithson's first project at the Hexenhaus: Axel's Porch.

Life is on stage

Peter Smithson referred to the Hexenhaus as 'Axel's personal theatre', a description that reveals the importance of theatre techniques and props in this stage of their work because 'the empty room is the same as the empty stage. You furnish it with those things necessary.'¹⁶⁴

The exhibition displays of that period, unlike earlier ones, had no pedestals, display cabinets or basic structures, they relied on the contents alone to create an atmosphere: inhabitation, illumination and decoration (furniture and accessories) – theatrical resources like those they had seen in the immediate post-war exhibition inventions of the Eameses – 'the material of exhibition itself together with light becoming the means of spatial organisation'¹⁶⁵ – and, on the real stage, in Bertolt Brecht's productions in the fifties. Surprisingly similar viewpoints that share "a compulsion towards the real"...for the sense of the action to be carried by free-standing real devices and by light'¹⁶⁶

The 1981 article 'The Masque and the Exhibition' was revised and published in 1993 as 'Staging the Possible' in an obvious reference to the theatre. However, the original article already mentioned the devices that could be used to create an intensity greater than reality itself and which could, therefore, be a wonderful mechanism for conveying the Smithsons' ideas. Mention must also be made of the similarity between these tools and those they acknowledged as typical of the architecture of the Fourth Generation – devices and decorations – whose mission was to signal changes of use.

164 Spellman and Unglaub, p. 64.

165 Peter Smithson, 'The Masque and the Exhibition: Stages Towards the Real'.

166 Ibid.

The 'Tischleindeckdich a.s.o.' exhibition (1993) was their first chance to put all these observations into practice and they jumped at the chance. The stand staged pieces of furniture by the four generations as 'actors in a staging of the possible' – separate elements that occupy space (a device applied previously at the 1986 Milan furniture fair) and which are dissociated from the wall (despite their proximity to it) by being set at a 45° angle. Singular pieces of furniture whose individuality is reduced when added to the stand as part of a group or flotilla that combines their forces in search of a far more ambitious common goal.

The scene is created by the theatrical transformation of familiar pieces of furniture. 'The transformation of these familiars in this exhibition is effected by paint and by light as in a theatre. All the pieces are painted the same dullish metallic green.'¹⁶⁷ The stand was flooded with green, spreading its 'ensemble' quality outwards and even beyond the confines of the Aedes gallery and providing this fairy ambiance with an anonymous framework in which the leading actors can stand out on their own: the Tischleindeckdich (the star of the show) and the possible visitors to the exhibition, its inhabitants. Everything is imbued with greenness, creating an atmosphere in which the pieces of furniture cease to be isolated objects and become part of the ensemble. A device which is, in fact, very similar to the 'as found' strategy of the 1950s according to which a building should never be regarded as an isolated building but an integral part of a built fabric.

The metallic green colour used for all the items in the 'Tischleindeckdich a.s.o.' exhibition managed to neutralise individual considerations and made spectators more aware of intellectual considerations, a device learnt from Brecht's plays, the ultimate aim of which was to make people change their mind. The intellectual aspect, that metallic green philosophy mentioned by critics after the first exhibition at the Mautsch gallery, was consequently not merely the staging of the future of furniture but the staging of that 'possible' architecture of the Fourth Generation. In other words, the properties of the architecture of conglomerate ordering.¹⁶⁸

167 Alison Smithson and Smithson, *The Charged Void: Architecture*, p. 592.

168 A building of Conglomerate Ordering...
 seems natural
 harnesses all the senses
 has a spatial presence
 has a capacity to absorb spontaneous additions, subtractions, technical modifications without disturbing its sense of order, indeed such changes enhance it
 can accept change of use
 is hard to retain in mind
 it brings all our senses into play through the widest possible range of differences
 has a thick building mass, wide but not very high and penetrated from the top for light and air
 has faces which are equally considered
 is an inextricable part of a larger fabric
 is dominated by one material
 seems pulled-down to meet the ground
 is lumpish and has weight
 has a variable density plan and a variable density section
 has bearing walls and columns which diminish in thickness as their load or need for mass diminishes
 has irregular column and wall spacing, responding to use and natural placing
 is ordered by its main circulation ways
 has its forms bond together by banding
 is constructed as a net statement of what is required.

The greenness was a blind step towards the idea of furniture that would make a room rather than a display. The events of the furniture suggesting the use of the space. Furniture should not just stand about, it should tell you how to use the room. Conglomerate ordering is a use ordering.¹⁶⁹

After Alison's death, Peter Smithson picked up the research she had begun with the 'On the Floor Off the Floor' exhibition five years earlier, an installation that featured many of the themes addressed by the 'Tischleindeckdich a.s.o.' exhibition and also the ideas outlined in one of Alison's last letters to Axel Bruchhäuser, dated 20 January 1993, whilst preparing the exhibition at the Aedes gallery. Her final instructions about the lighting and position of the furniture are followed by an epigraph entitled 'The Future' in which she outlines her ideas for a hypothetical future exhibition.

For the middle of the decade, a 'room' exhibit is something you can think towards... it means you have ideally to be included in a series of rooms by named artists, either in a gallery or in a shop [like Liberties who had such an event or the Daily Mail Ideal Home Exhibition]...
[...] Maybe we work towards a 'room' so as to be ready for such possibility. All we may know is the roof has to be glass, at a slope, even undulating; with layers of tent-like blinds; that three visible walls have to be half silk curtain, half a [photographic] view to a garden; that the floor is 'soft', even undulating; that the silk lanterns are there as the microcosm of the macrocosm; that the dispersed items are all low to the ground: TT1, TT2, Collector's Table, ...and the Hausgarten mark 2 or 3 stands up as the garden within...maybe its flower should be silk? ... say if I should make one to try.¹⁷⁰

An intellectual testament offering a glimpse of her ideas for what would have been her next exhibition staging or, in other words, the new staging of her interpretation of architecture.

The ideas set forward in this missive hark back yet again to the 1950s and the symbolic habitat of the Patio and Pavilion stand in the news once more following its reconstruction in 1990. 'The roof has to be glass, at a slope, even undulating' suggests a direct reference to the translucent, corrugated plastic roof of the pavilion; the 'view to a garden' suggests the presence of nature and the existence of a surrounding void; 'the floor is "soft", even undulating' like the sand covering the floor; 'the dispersed items are all low on the ground' like the signs of life provided by Nigel Henderson and Eduardo Paolozzi.

Patio and Pavilion resurged as a new staging of their ideas almost forty years later because of its timeless quality. 'Patio and Pavilion is a picture of the art processes of the period of Samuel Beckett, Jean Dubuffet, Jackson Pollock and Bertold Brecht.'¹⁷¹

Except from 'The Canon of Conglomerate Ordering' in Alison Smithson and Peter Smithson, *Italian Thoughts* (Stockholm, 1993), p.62-63.

169 Edited transcript of a lecture given by Peter Smithson at the School of Architecture and Building Engineering, University of Bath on 18 February 1995. Published in Helena Webster, ed., *Modernism without Rhetoric: Essays on the Work of Alison and Peter Smithson* (London: Academy Editions, 1997). p.193.

170 Smithson, Alison (1993, January 20). [Letter to Axel Bruchhäuser]. Alison and Peter Smithson Archives. TECTA Archive, Lauenförde.

171 'Phenomenon in Parallel: Eames House, Patio and Pavilion' in Alison Smithson and Peter Smithson, 'The Nature of Retreat', *Places*, 7 (1991), 8-23.

Hence it was and continues to be the reflection of action as a generator of art, of the person and in consequence of the art of inhabitation. 'And to discover within our own work an unconscious persistence of "the track" as a binding element, an essential part, of the mechanism of "conglomerate ordering", is an example of observing persistence within a work life.'¹⁷²

As in the case of *Patio* and *Pavilion*, the displays Alison Smithson created in conjunction with TECTA in that period – including those intended simply to showcase a new furniture design, a book launch or fully-fledged exhibitions – were statements about occupancy and territory rather than programmes announcing a particular style or approach. Conglomerate ordering is use ordering, it is not an aesthetic device.

In the 'On the Floor Off the Floor' exhibition, Peter Smithson pursued the theme first addressed by Alison. This exhibition obviously has features in common with both 'Tischleindeckdich a.s.o.', the last exhibition directed by Alison, and her ideas about the future mentioned earlier.

Once again the display consisted solely of furniture made by TECTA transformed by paint and light to create another staging, that of furniture as a vehicle for a lifestyle: the way of life *on the floor* and *off the floor*. The exhibition in the Mautsch gallery was the staging of a 'room' that Alison had hoped for. A room that should not, however, be seen as a furnished space but as an open work of art intended to make people think. In this case too, individual factors are neutralised in order to highlight the intellectual aspects of the display – again by using colour. The atmosphere is tinged with metallic silver (the same metallic silver that Alison began to use in 1992 for the invitation to the Cologne fair) instead of metallic green. This neutral tone pursued the idea of using softer colours to make the furniture merge discreetly into the scene and create an ensemble whilst highlighting the art of inhabitation. The inhabitant is not present in the exhibition but acknowledged by signs of occupancy. Empty chairs, to be specific, convey two parallel life styles that once again reflect a standpoint

A staging of the Smithsons' thought which – for the first time since the 'House of the Future' – can be observed but not inhabited. An abstraction of ideas whose symbolism is obvious in the pictorial rather than real-life overhead view of the exhibition featured on the cover of the invitation-catalogue. A photograph of the display taken from a very unusual viewpoint which flattens the objects and highlights their shadows. Light was successfully used for dramatic effect in the 'Tischleindeckdich a.s.o.' exhibition at the Aedes gallery, but in the 'On the Floor Off the Floor' exhibition its impact was increased exponentially by the chosen viewpoint and the cast shadows incorporated into the composition. Shadows can reconstruct objects and convey information about the light and air around them, about their spatial presence beyond the physical boundaries that become blurred and changeable, and materialise the space between the private realm and the public domain. In short, shadows materialise and incorporate the variables of time and place into the concept.

172 Alison Smithson and Smithson, 'The Nature of Retreat'.

The idyll of inhabitation

Furniture is no longer seen as merely movable items for furnishing a home but as an enabling frame acting as an interface between users and space which not only extends their capabilities but also adapts to cater for their personal circumstances. The Trundling Turk, for example, was designed to enhance users' freedom by encouraging them to sit differently and also as a social device. Likewise, the Waterlily/Fish Desk was as an aid to thinking. The furniture of the Fourth Generation was an extension of their users and could not, therefore, be left out of the staging, pushed against the wall. As Alison said in 1986, it was necessary to 'think again of furniture as occupying positions in our spaces other than backed against a wall. Furniture of all functions can take position in space as collector's pieces; art works.'¹⁷³

Furniture is a framework which, like St Jerome's desk, enables a place – indoor or outdoor, in the city or the country – to be inhabited and which represents the idyll of inhabitation. This idea featured in the first Trundling Turk (1954), 'a chair which looked as if it might follow its owners from room to room and out onto the beach'¹⁷⁴ and was also particularly obvious when the Tischleindeckdich went on show in 1993. The table was officially launched in an art gallery but the photos used to advertise it showed it in the country in a winter landscape (fig.50) – yet another reference to the fairy tale which inspired it.

When it suited him [the tailor's son] he did not enter an inn at all, but either on the plain, in a wood, a meadow, or wherever he fancied, he took his little table off his back, set it down before him, and said, spread yourself, and then everything appeared that his heart desired.¹⁷⁵

This was not only the case of the table: the 'Tischleindeckdich a.s.o.' exhibition also featured 'pieces of furniture for "wandering" which could, to a certain extent, simulate a home anywhere.'¹⁷⁶ They were a reflection of a society in motion – as were the renaissance paintings of the study of St Jerome: 'an allegory for the freedom to choose the country in which one works, something the Roman world offered, something that we like to do today.'¹⁷⁷

The Tischleindeckdich table began to be designed in 1991, the year when Alison Smithson exhibited together with ТЕСТА at the Milan furniture fair a new version of the study of St Jerome and published her essay *Hieronymus/Saint Jerome: The Desert, The Study*, two apparently different ventures which did in fact have much in common.

The Tischleindeckdich table, like the study of St Jerome, is the enabling frame or interface between users and their surroundings which involves people aligning

173 Peter Smithson and Karl Unglaub, *Flying Furniture: Unsere Architektur Rollt, Schwimmt, Fliegt = Our Architecture Rolls, Swims, Flies* (Cologne: König, 1999), p. 18.

174 Alison Smithson and Smithson, *Alison + Peter Smithson: The Shift*, p. 22.

175 Jacob Grimm and Wilhelm Grimm, *The Complete Grimm's Fairy Tales*, Knickerbocker Classics (MBI Publishing Company, 2013), p. 130.

176 'Möbel für die Wanderschaft gewissermaßen, die überall ein Zuhause simulieren.' Holger Schnitgerhans, 'Tischlein Deck Dich Usw...', *Architektur & Wohnen*, 1993, offprint.

177 Alison Smithson and Smithson, 'The Nature of Retreat'.

their relationship with their location, be it indoor or in nature. Whereas the 'as found' concept of the 1950s arose as the response of the building to place, the core concept from the late 1970s and particularly the 1980s onwards was the relationship (and not only the response) of the inhabitant to place. The experience, feeling and action were at the heart of the concept and therefore what mattered was to implement devices able to extend the arts of inhabitation beyond their physical boundaries.

The fixed lattices of the 1970s were the device that made it possible to give place to the arts of inhabitation. The lattices that shaped the Christmas exhibitions were designed as enabling frames ready to receive users' signs of occupancy. As the previous chapter explained in depth, that series of exhibitions gradually developed a framework appropriation strategy in which users and their occupancy gradually increased in importance. The exhibition stands created in conjunction with TECTA, however, did not need any accessories because the intention was to demonstrate that it was possible to inhabit space or convey a message or idea simply by means of furniture and their inhabitation. Furniture itself was now able to fulfil this function. Lattices featured new properties tried out in the previous series of exhibitions, properties related to 'skin-depth, sense of protection; exploiting the sense of privacy and of fantasy'¹⁷⁸ which enabled lattices to be explored further as the interface between users and their surroundings in the form of branching lattices which provided the basis for three families of devices and decorations: lattice screens, lattice paravents and lattice furniture.

The lattice screens became movable elements, more visual than structural, that embodied the paradox of building a boundary by blurring it. Axel's Porch was the spearhead of this series of screens added to the Hexenhaus and the TECTA factory with a view to linking their users to their surroundings. A layer between the building and the landscape able to embody that link between the indoor and the outdoors and therefore bring them together by means of the user's appropriation and usage. 'To conceal, or to part-conceal or to display is achieved by the movement of the lattice not by the movement of the person behind the lattice',¹⁷⁹ as was the case of the last link in the previous series, the 'Christmas-Hogmanay' exhibition. This was a new kind of enabling frame that increased the possibilities of interaction between the place and its inhabitant, the real and only leading figure.

Likewise indoor lattice paravents give the inhabitant protection, shelter and calm, as seen allegorically in the study of St Jerome too. These folding and also movable screens enabled different degrees of privacy depending on how the lattices overlapped. 'It can allow one to "select-out", to see what one wishes to see'¹⁸⁰ like the staging of the 'On the Floor Off the Floor' exhibition.

The lattice screens and paravents dissociated themselves from the structural logic and experimented with the section of uprights. The lattice became a membrane 'which has the effect of isolating and intensifying the fragments seen through the

178 'Three Generations' Alison Smithson and Smithson, *Italian Thoughts*, p. 15.

179 Peter Smithson, 'The Lattice Idea', *ILAC&UD Yearbook 1999*, 58–61.

180 Ibid.

lattice'.¹⁸¹ Its thickness and geometry depended on the context and purpose, hence the different solutions provided for Axel's Porch, the ТЕСТА Canteen Porch and Brodia Road.

Finally, the lattice furniture featured the inherent structural logic of the lattice which evolved from the diagonal braces of the Heroic Period. In furniture, the lattice is the framework, the long-lasting element that underpins and enables the interplay of the transient upholstery symbolising its appropriation by the user. The Smithsons used this device in the 1970s in both the series of furniture with a plastic structure entered for the Interdesign 2000 competition (1972) and the design of the San Diego Chair (1976) made of wood. In the 1990s, however, Peter Smithson incorporated into the design the traditional steel tube from the heroic period which was the basis of braces, and ТЕСТА's cantilevered language into the lattice forming the frame. The lattice furniture series including the lattice table, chair and sofa and Popova's chair, embodied the fusion of ideas from ТЕСТА, the Smithsons and their shared reference, the 1930s.

In short, the lattice was, in one way or another, the basis for receptive, interpretable, dressable furniture and also for receptive architecture: the so-called 'architecture of the lightness of touch'.

When we say that 'lightness of touch' can allow a building to be interpretable we mean being capable of being read in different ways by the occupiers so it becomes theirs without itself being changed; and when we say it should permit a building to be 'dressable' we mean capable of responding to occupiers or community seasonal or festival decorations, or to temporary changes, without the underlying structures or meanings being destroyed – in fact these structures and meanings being enhanced by such 'dressing'.¹⁸²

The porch is a device that makes architecture 'dressable' and able to be interpreted from both the inside and the outside. The aim is not to achieve the indoor-outdoor continuity proposed by the first modernist architects but to focus on the specificity able to characterise the interior on the basis of its exterior, and the exterior on the basis of its interior: 'inside outside: outside inside'.¹⁸³ With this in mind, the outer walls were split into multiple layers like a dynamic constellation of decoration, furniture, seasons, light, vegetation, etc., whose bonds were underpinned by an order based on usage and appropriation: conglomerate ordering.

Each of these layers surrenders its individual nature and blends into a single whole that constitutes a stage waiting for its actors and its inhabitation. This strategy was tried out for the first time in the 'Christmas-Hogmanay' exhibition in which single-direction lattices evoked the seasonal layers of Scottish weather, amongst which the exhibits could be found, and which the visitors were invited to decorate with their presence. The inhabitant is the centrepiece that always stands out for, as the Smithsons said in 1978, 'if a building is to give access to its occupants – access

181 Ibid.

182 Peter Smithson, 'Lightness of Touch', *Architectural Design*, June (1974), 377–78. (Lecture at Harvard in 1972).

183 See Peter Smithson, 'Inside Outside: Outside Inside', *ILAE&UD Yearbook 2000*, 82–85.

to their affections and skills – [...] one way is through layering... for between layers there is room for illusion, and for activity'.¹⁸⁴

Into the Air

The porch brings about a transformation by adding a layer of air over the building, a plane of pause between the built and the void, a bridging element between the user and the spatial territory immediately around.

A building needs this 'adherent air' to maintain its inhabitants and its own – for want of a better word – self-esteem.

Future buildings will also need inevitable-seeming extensions or 'antennae' that will mark them as those of a green generation of buildings; these antennae will be a building's reaching into the air, to signal possession of its 'adherent air'.

[...]

The reaching out theme 'into the air' is for me a kind of beginning to recognize that a certain space adherence belonging to existing objects, furniture, buildings, places, landscape must not be violated.¹⁸⁵

This 'space adherence' was obvious in the shadows forming part of the 'On the Floor Off the Floor' exhibition and, to a certain extent, in the circular cut-outs swirling around the exhibits in the 'Tischleindeckdich a.s.o.' exhibition – elements that materialised the air surrounding and giving each exhibit a meaning, and reminded visitors of the need to ensure a surrounding void.

The importance of the void in built structures was not a new concept: the Smithsons' projects in the 1950s already featured a fragment of inviolate territory, usually a patio, as a symbol of identity. 'Patio and Pavilion' was a pavilion in a patio. The House of the Future was a patio encapsulated by its pavilion. Both speak of a portion of the sky.¹⁸⁶ Both of these projects, like almost all the Smithsons' work, feature an enclosed void giving all inhabitants their own portion of sky and a small territory linking them to a place.

Air and earth were always inspiration for the Smithsons' projects, regardless of the scale, so this approach is valid for town planning too: 'What we are trying to offer is an urbanism where the specificity arises from the space-between [...] The space-between speaks to the sky...the space-between puts a charge into that sky. The sky is changed. The response to it therefore changes.'¹⁸⁷

The concept focuses first on the sky and the ground as signs of identity but then more layers are added – the seasons, light, shadows, trees, creepers, etc. – in a celebration of the material pleasures of being in a specific location. In her 1989 essay 'Into the Air', Alison Smithson wrote that 'this acceptance of vegetation, of nature's

184 Peter Smithson, 'Some Further Layers: Work and Insights', *IL&UD Yearbook 1978*, 78–79.

185 Alison Smithson, 'Into the Air', *MASS. Journal of the School of Architecture and Planning*, VII (1989), 7–10. The phrase 'into the air' was coined whilst working on the Maryhill flats projects in Glasgow (1984).

186 Alison Smithson and Peter Smithson, 'The Nature of Retreat.' It was also at this time that the Smithsons created the 'Private Sky' diagram showing how all homes, regardless of their layout, were entitled 'to address a portion of the sky with its, as yet, unbreathed air.' Alison Smithson and Peter Smithson, *Ordinariness and Light: Urban Theories 1952–1960 and Their Application in a Building Project 1963–1970* (MIT Press, 1970), p. 164.

187 Alison Smithson and Peter Smithson, *The Charged Void: Urbanism* (New York: Monacelli Press, 2005), p.15.

contribution as another “life” or external “inhabitant” of a building is one way of giving some buildings fibrillatory “antennae”¹⁸⁸ and constitutes, like the creepers veiling the façade of St. Hilda’s College, the physical expression of the air that gives the inhabitant a sense of peacefulness and protection.

The Smithsons experienced the pleasures of country life at Upper Lawn, their country home in Wiltshire, where the surrounding patio provided a private portion of land and sky. Here like nowhere else they deployed their ideas about inhabitation ‘and by the affection, invention and labour of its inhabitants it has become [became] a different work with the turn of the seasons’.¹⁸⁹ During their days at the pavilion, they recognised more layers that were added to the permanent fabric: ‘the layers added by the occupiers, red-currant canes against the walls, flags flapping against the sky; and in winter snow covers all with a layer of magical transformation’.¹⁹⁰ This new sensibility is mentioned in *Upper Lawn: Folly Solar Pavilion*, a book consisting of fragments, experiences and memories that show how the pavilion fades into the background behind the life of its occupants, and how minor changes in decoration can change everything. In the introduction to the book, Peter Smithson said:

Upper Lawn was a device for trying things out on oneself.

It was here we explored the small adjustments, the temporary decorations, the invention of those signals for change which we later would come to recognize as being the necessary work of the fourth generation of the Modern Movement.¹⁹¹

But in 1981, unfortunately, they were obliged to sell the house when new neighbours arrived: ‘Noise, the sense of territory invaded, do not seem easy to submit to’.¹⁹² This distressing situation gave rise to different thoughts about the pavilion that culminated in ‘A Fragment of An Enclave’, a seminar at ETSAB in 1985–86. In the opening lecture that Alison gave at that seminar, she concluded that land was necessary in order for the pavilion to remain an idyll and to permit the illusion of an idyllic life, and that what mattered in that instance was not formal solutions but the pavilion in an enclave, in a domain.¹⁹³

The porches, the furniture, the exhibitions as devices and decorations typical of the Fourth Generation spread from inside outwards creating a new sphere of influence in the territory and enabling the art of inhabitation they themselves had experienced at Upper Lawn to unfurl seamlessly. But to achieve this, air was necessary, a surrounding space, a ‘fragment of the enclave’, and ‘if in the immediate future we begin to create fragments of enclaves that protect our inhabitation, we may come to live closer to the

188 Alison Smithson, ‘Into the Air’.

189 Peter Smithson, ‘Some Further Layers: Work and Insights’.

190 Ibid.

191 Peter Smithson, 13 October 1985. In Alison Smithson and Peter Smithson, *Upper Lawn: Folly Solar Pavilion*, *Arquitectura i Urbanisme* (Universitat Politècnica de Catalunya, 1986).

192 Ibid.

193 Alison Smithson, *The three pavilions of the third quarter of the 20th Century*, lecture at Universitat Politècnica de Catalunya (1 January 1985) <<https://upcommons.upc.edu/handle/2099.2/469>> [accessed 7 April 2015].

idyll represented in the Renaissance by Saint Jerome's two habitats.¹⁹⁴

These ideas clearly drew parallels between the idyll of St Jerome's habitat and the backdrop of the late twentieth century, a time when voices began to make themselves heard about ecology and the responsible use of planet earth's resources. TECTA's stand at the 1991 Milan Furniture Fair was the venue chosen to present to the public the study of St Jerome as an allegory of the idyll of inhabitation: the study as an allegory of life in an urban setting, and the desert, of life in harmony with nature.

Projecting this foresight of a society becoming more climate, nature, energy resource responsive, the alternative ideals of the habitats of Saint Jerome might be thought to exist in the same *fragment* of the easily defensible *enclave*. A merging of the old reciprocity will allow us to begin to think of a new form of restorative habitat for a future *light-touch* inhabitation of the earth.¹⁹⁵

At this point, the Smithsons became aware of the need for untouched territory in order to safeguard inhabitation, similar to the allegory embodied by St Jerome and the grotto, regardless of the scale on which they were working. Inhabitants are buoyed up by air, by the void able to provide them with their fragment of protection in an enclave. A void which the Smithsons first sought inside the home by liberating it from the avalanche of invading appliances; then outside the home in the form of a patio which constituted the final bastion of privacy and identity; and finally by incorporating the surrounding air which defines and blurs the boundaries of inhabitation. An architecture 'without rhetoric' which tends to disappear but is able 'to charge the space around it with an energy which can join up with other energies, influence the nature of things that might come.'¹⁹⁶ In other words, an architecture which is a frame of 'the charged void', that place receptive to its inhabitants and their arts of inhabitation, and able to house different circumstances and moments.

A 'charged void' that characterised the furniture, the Waterlily/Fish Desk, the Collector's Table, the Cornell Boxes, the Trundling Turk, the Tischleindeckdich and so on, but also became part of architectonic thought by explicitly asserting itself in the two key exhibitions of that period: 'Tischleindeckdich a.s.o.' and 'On the Floor Off the Floor'. But the projects carried out at the TECTA factory in Lauenförde and particularly at the Hexenhaus were obviously the paradigm of this concept and as such they can only be understood together with their surrounding void, the meadow or the woods being their 'fragment of an enclave'.

All the exhibitions held in conjunction with TECTA, from the trade fairs simply showing new furniture designs to the most thought-provoking exhibitions, are part of an interconnected whole featuring interwoven ideas about land, city, tradition, lifestyle and the style of the period. A whole not unlike a 'plum pudding: some ingredients are still recognisable but most are an inextricable part of a general mass.' A lump of conglomerate ordering that brings together all the Smithsons' efforts since

194 Alison Smithson, *Hieronymus/Saint Jerome: The Desert, The Study* (Lauenförde: TECTA, 1990).

195 Alison Smithson, *Hieronymus/Saint Jerome: The Desert, The Study*.

196 The opening words of the latest compilation of their work *The Charged Void: Architecture*, and the reason for its title. In Alison Smithson and Peter Smithson, *The Charged Void: Architecture*, p. 11.

the 1950s with remarkable consistency and is always underpinned by the same goal: to provide a place for the arts of inhabitation.

However, if we look at their work in that period dispassionately we might wonder, just as Alison did about the work of her beloved Charles and Ray Eames and Gerrit Rietveld, 'What's so great about what they did? Just a house and a few chairs.'¹⁹⁷

197 Bauen & Wohnen, July, 1965. Smithson and Unglaub, p. 188.

Images Sources

Alison and Peter Smithson Archiv / ТЕСТА Archiv Lauenförde. (fig. 1-3, 5-7, 14, 38-39, 43, 47, 51, 53-56, 68, 71, 73, 80, 83, 84, 86-90, 97-98, 106-110, 119-121, 125, 126-128, 130)

Harvard Design School, Frances Loeb Library, Special Collections Department, The Alison and Peter Smithson Archive. (fig. 22, 25, 36, 44-46)

Marco Vidotto, *A + P Smithson : Pensieri, Progetti E Frammenti Fino Al 1990* (Genova: Sagep, 1991) (fig. 4, 81)

Alison Smithson and Peter Smithson, *Alison + Peter Smithson: The Shift*, ed. by David Dunster, Architectural Monographs no.7 (London: Academy Editions, 1982). (fig. 8-9, 42)

Peter Smithson and Karl Unglaub, *Flying Furniture : Unsere Architektur Rollt, Schwimmt, Fliegt = Our Architecture Rolls, Swims, Flies* (Cologne: König, 1999). (fig.10-11, 13, 17-18, 20-21, 23, 26-28, 32, 40, 49, 57-58, 70, 77, 82, 92, 94-96, 99, 111-112, 114, 116, 122-124, 127-129)

Jack Birns, The LIFE Images Collection, Getty Images. (fig. 12)

Alison Smithson and Peter Smithson, *The Charged Void: Architecture* (New York: Monacelli Press,

2001). (fig. 15, 69, 118)

Axel Bruchhäuser, *Der Kragstuhl / The Cantilever Chair* (Berlin: Alexander Verlag, 1986). (fig. 16)

Dirk Van den Heuvel and Max Risselada, *Alison and Peter Smithson - From the House of the Future to a House of Today* (London: O10 Publ., 2004). (fig. 19, 24)

Donald Albrecht, ed., *The Work of Charles and Ray Eames: A Legacy of Invention* (New York: Harry N. Abrams Inc., 2005). (fig. 29)

Alison Smithson and Peter Smithson, *Upper Lawn: Folly Solar Pavillion*, *Arquitectura i Urbanisme* (Universitat Politècnica de Catalunya, 1986). (fig.30)

Enric Miralles, 'On the trundling turk', *Arquitectura COAM*, July (1992). (fig. 31)

Alison Smithson, *Hieronymus/Saint Jerome: The Desert, The Study* (Lauenförde: ТЕСТА, 1990). (fig. 33-34, 37)

The National Gallery, London 2015. (fig. 35)

Alison Smithson, 'Into the Air', *MASS. Journal of the School of Architecture and Planning*, VII (1989). (fig. 41)

Jacob and Wilhelm Grimm, *Tischlein Deck Dich* (pictures by Fritz Kredel) (Postdam: Struwelpeter-Original-Verlag, 1991). (fig. 48)

Holger Schnitgerhans, 'Tischlein Deck Dich Usw...', *Arcitektur & Wohnen* (1993). (fig. 50)

Axel Bruchhäuser (fig. 52, 60)

Helena Webster, ed., *Modernism without Rhetoric: Essays on the Work of Alison and Peter Smithson* (London: Academy Editions, 1997). (fig. 59)

Peter Smithson, 'Restaging the Possible', *ILA&UD Yearbook 1995*. (fig. 61, 115)

Mathias Hirche, *Tischleindeckdich Usw.! Galerie Aedes Berlin* (Berlin, 1993). (fig. 62-67, 72, 74-76, 78-79)

Thyssen-Bornemisza Museum, Madrid. (fig. 85)

Peter Smithson, 'Being at Home', *ILA&UD Yearbook 1997*. (fig.91)

Peter Smithson, 'The Lattice Idea', *ILA&UD Yearbook 1999* (fig. 93, 113, 117)

Christina Kiaer, 'The short life of the equal woman: Russian female artists', Tate Gallery (2009) <<http://www.tate.org.uk/context-comment/articles/short-life-equal-woman>> (fig. 100-102)

Andrew Wachtel, 'Constructivist theater', Northwestern University (2002) <<http://max.mmlc.northwestern.edu/mdenner/Drama/plays/constructivist/constructivist.html>> (fig. 103)

Bridgeman Art Library, Tretyakov Gallery, Moscow. (fig. 104)

The George Costakis Collection, State Museum of Contemporary Art, Thessalonica. (fig. 105)

Ute Rech, *Reise* (Cologne: Ed. Hundertmark, 1999). (fig. 131)

Epilogue

As the arts of inhabitation flower, buildings reach up into the air to signal the new awareness: new responsiveness to nature; new compatibility between things; the enjoyment of all our faculties.¹

In August 1986, Alison Smithson and Axel Bruchhäuser, under the watchful eye of Peter Smithson, visited Bruchhäuser's house, known as the Hexenhaus (witch's house) to lay out the foundations of the porch that was to mark the beginning of a magical transformation of this house and its surroundings, the fairy woods of Bad Karlshafen. A spark that was to trigger a transformation that extended beyond the porch's physical limits and profoundly influenced the feelings and lifestyle of its users (a man and his cat) and also the Smithsons' own way of seeing and doing architecture.

The porch project had begun two years earlier when Axel Bruchhäuser wrote to the Smithsons to ask them to build two lookouts (two of the five designed by the Smithsons for the Kingsbury Water Park as part of the 1977 Art into Landscape competition) at the Hexenhaus. His letter, received shortly after the Smithsons' first inroads into furniture design, not only led to a series of projects spanning almost twenty years but was also the start of a very special correspondence between them 'based on an elective affinity that went beyond words'.²

Finally, after a great deal of discussion, one lookout was built instead of two (the Yellow Lookout based on the Straight Climb Lookout entered for the 1977 competition) and instead of locating it in the woods around the house it was built in the garden court of the TECTA factory in 1991. During one of these conversations, Axel said he wanted his house to have a new door leading into the garden so that he could enjoy his surroundings more. Alison granted his wish with a new way of doing architecture.

In a very short space of time, Alison Smithson took over from Stefan Wewerka as TECTA's main advisor. The TECTA factory exhibition pavilion designed by Wewerka and inaugurated in 1985 celebrated him having worked there for more than ten years, but just one year later at the 1986 Milan Furniture Fair, Alison was in charge of the TECTA stand 'The Future of Furniture. The Furniture of the Fourth Generation' which showcased the Waterlily/Fish Desk and the Collector's Table. This exhibition was a

1 'Territorial Density' Alison Smithson and Peter Smithson, *Italian Thoughts* (Stockholm, 1993). p.46.

2 Maddalena Scimemi, 'Alison E Peter Smithson: La Hexenhaus', *Casabella*, 2004, 7–21.

As a matter of fact, Bruchhäuser decided to write this letter under the name of Karlchen, his cat, and addressed it to Snuff, the Smithsons' cat, giving rise to much more than just the start of a professional commission: it was the turning point that changed the dimension of their relationship from then onwards.

manifest and fleeting shift in TECTA's outlook away from the precise, craftsmanship reproductions of avant-garde furniture for which it was so famous towards a new, experimental era imagining the future under Alison's guidance.

This was the start of new period for TECTA and also for the Smithsons because that exhibition revealed a deliberate shift in their architectural focus that was reflected in their furniture for a new generation, furniture in response to a new lifestyle, furniture that also implicitly embraced the Smithsons' new approach to architecture – which they classified from then onwards as fourth-generation architecture. An architecture which they also managed to start materialising that same year in their first project at the Hexenhaus: Axel's Porch which, despite being a very small construction covering barely eight square metres, was so intense that it marked a point of no return in all respects for everyone involved.

A porch is one of those devices which can transform the whole meaning of the place to which they give entry: it can have an intensity, which catches, in miniature, the intentions of its period.³

The porch became the device that embodied the spirit of renewal tried out earlier by the Smithsons in the Christmas exhibitions. Firstly, by focusing on the meaning and importance of inhabitation itself in 'The Entrance Made Festive' exhibition (1976) – a chance for Bartlett students to see for themselves how occupancy could in itself be an art; and then in the '24 Doors to Christmas' exhibition (1979) by providing the enabling frame for this inhabitation whilst allowing space to be appropriated, but not concealed; and, just one year later in 1980, in the 'Christmas-Hogmanay' exhibition by dissociating the frame from the content and then breaking the frame down into latticed cages that conjured up a Scottish atmosphere inside the Fruitmarket Gallery.

The final link in this line of thought, in which theory and practice followed each other in a series of Christmas-themed events, was meant to be the 'Come Deck the Hall' exhibition of 1981 which Alison intended to be not so much an exhibition as an event in which the public could actively participate by contributing the decorations and ephemera for the display, making them responsible for the end result. The architecture was merely a dressable support or interface, the enabling frame upon which decorations would gradually accumulate.

To enable people to 'deck the hall', Alison Smithson suggested the construction of a scaffolding, a wooden, many-branched hall apparently inspired by the structures of historic timber buildings in England mentioned in Cecil A. Hewitt's book, *English Historic Carpentry*. But unfortunately, despite Alison's efforts to bring about this exhibition intended to give visitors a sense of collective responsibility for the look of places, it was never held.

Branches that move and branches that don't

The work and research carried out for that unaccomplished exhibition did, however, finally come to fruition in the porch built at the Hexenhaus shortly afterwards. The preliminary sketches for the framework of said exhibition could also well be regarded

3 'Gates, Porches, Portals' Smithson and Smithson, *Italian Thoughts*, p.53.

as the formal, material and conceptual basis for the lines of the Hexenhaus porch. Even the first reference, the analysis of historic English timberwork buildings once stripped of their heavy outer walls in Hewitt's book, is to a certain extent a foretaste of the contrast between the German-flavoured 'as found' *Fachwerkhaus* (timber framing), the Hexenhaus, and the new addition proposed.

The porch designed by Alison Smithson for Axel Bruchhäuser and his cat pursued the construction method of the existing house but without the white stucco filling in an attempt to create a new bond between the interior of the house and the surrounding landscape. To a certain extent, the geometry of the porch was a combination of the two: a latticed frame which echoed both the lines of the load-bearing structure of the house and the branches of the trees. The outcome was the 'branching lattice' in which two-dimensional timberwork re-creates three-dimensional tree branches: 'so the porch...whose frame supports the all-around glass that is as a built part of the wood; two built trees whose branches cannot move with the seasons'.⁴

The branching lattice alludes to the simplified silhouette of a tree, the abstraction of the outline of its branches, a structure that grows and changes naturally like deer antlers or the patterns of association found in the cluster diagrams of the 1950s. These *parti* diagrams portrayed urban reality on the basis of an open framework able to deal with a constantly changing society. An organisation developing in an unfettered but orderly manner.

It was necessary in the early '50's to look to the works of painter Pollock and sculptor Paolozzi for a complete image system, for an order with a structure and a certain tension, where every piece was correspondingly new in a new system of relationship.⁵

These specific relationships based on a network of identified associations in art were also, the Smithsons believed, to be found in the human sphere. Hence the cluster was based on the creation of a basic infrastructure providing support for transformation and change. 'A finite structure able to generate infinite effects.'⁶ Likewise, the lattice became the layer that enables layering, an intermediate element that not only hosts the infinite relationships possible between the inhabitant and the landscape but increases them.

Instead of building a flat boundary, the branching lattice becomes a realm, a built place able to ensure that ambiguous space between, able to gather together and blur the layers of the seasons, of light and shadow, of the trees, of the house, of the inhabitant. Countless situations, perceptions and possibilities that come together for

4 Alison Smithson 1988. These words (not appearing in the published version) are taken in the draft of 'Lattice Screens and Paravents' in the *On the Floor Off the Floor* catalogue found at the Harvard Design School, Frances Loeb Library, Special Collections Department, The Alison and Peter Smithson Archive: An Inventory. They subsequently appeared in Alison Smithson and Peter Smithson, *The Charged Void: Architecture* (New York: Monacelli Press, 2001), p.552.

5 Alison Smithson and Peter Smithson, *Urban Structuring: Studies of Alison & Peter Smithson*, A Studio Vista/Reinhold Art Paperback (London: Studio Vista, 1967), p.34.

6 Marina Lathouri, 'Frame and Fragment: Visions for the Modern City', *AA Files*, 2005, 58-67.

just one moment, a continuous aesthetics of change which 'like the coloured crystals of a kaleidoscope, offers us images of successive states of repose always different, instantaneous, fragile...'⁷

The above comment – taken from the introduction to the book *Upper Lawn: Folly Solar Pavilion* in which Enric Miralles highlights the sensory richness generated by the architecture of layering that the Smithsons tried out at Upper Lawn by incorporating particularities of nature into the layering – could obviously apply to the Hexenhaus. In addition, this device was taken even further in the Hexenhaus by incorporating the lattice members forming the porch structure into the layered interplay as if they were real tree branches in the surrounding wood.

The branching lattice tried out in the porch did not create a homogenous, abstract plane like the panels forming the latticed cages in the 'Christmas-Hogmanay' exhibition but a ramified structure that carved out its own presence in space. The braces were substantial and quite thick because of their two-fold function: structural and also visual.

The porch consists of seven centimeters timbers whose edges and shadows merge together where they overlap with the boughs on the trees in the surrounding wood. However, these bars also form a frame which isolates and highlights individual objects or collections, and increases visitors' awareness of the world around them by creating segmented views of its fragments. 'The thickness of the lattice bars effects what is seen much in the same way as the frame effects the sense of space in a picture.'⁸

The decoration and lifestyles taking place inside spread outwards and affect the world outside. In the meantime, inhabitants can enjoy the natural patterns of the seasons, sun or snow, wind or rain, from within the shelter of the porch. In addition, the lattice makes the inhabitants part of the layering interplay by transporting them to a magical dimension where a stream of reflections, framing and mirror effects overlap to create a myriad of unexpected encounters and sensations. The outcome, like in the 'Tischleindeckdich a.s.o.' exhibition, is a fairy-tale atmosphere – far removed from the concept of seamless interior-exterior space that characterised architecture in the Heroic Period. The 'outside inside' in the case under study here is different and has to do with 'what is actually seen and felt at a specific place, outside inside and inside outside'.⁹ The Hexenhaus is a combination of both.

For Alison and Peter Smithson, Axel's Porch was the real-life materialisation of the image-landscape featured in the exhibition 'A Parallel of Life and Art'. The aim of this exhibition, characterised by layers of images, was mainly 'to offer some evidence of a new attitude', and emerged in fact as a result of 'Documents 53', a sort of manifesto submitted by the Smithsons to the Institute of Contemporary Arts in

7 Enric Miralles in Alison Smithson and Peter Smithson, *Upper Lawn: Folly Solar Pavilion*, Arquitectura I Urbanisme (Universitat Politècnica de Catalunya, 1986).

8 Peter Smithson, 'The Lattice Idea', *IIA&UID Yearbook 1999*, 58–61.

9 This subject is examined in depth in the article by Peter Smithson, 'Inside Outside: Outside Inside', *IIA&UID Yearbook 2000*, 82–85.

1952. By juxtaposing mainly photographs and diagrams, that exhibition showcased the most recent manifestations of man's activities, creating countless associations and analogies between them. The material for the exhibition was selected by Nigel Henderson, Eduardo Paolozzi, Ronald Jenkins and the Smithsons in order to 'provide a key – a kind of Rosetta Stone' able to decipher the secrets of a new era that the exhibition made visitors aware of. The material was selected 'to show not so much the appearance as the principle – the reality beneath the appearance – that is, those images which contain within them the seeds of the future'.¹⁰ At that time in the 1980s, Axel's Porch, in addition to the 'poetic-lyrical order' of its layered images that 'create cross-relationships',¹¹ was once again the symbol of a new beginning. It was the seed of a new awareness and a new responsiveness: the architecture of the Fourth Generation.

The blurring boundaries of architecture

This architecture, in keeping with a new era triggered off by a small opening to the rear of the Hexenhaus, was the start of a transformation that made the envelope fade away. A gradual disintegration of the architecture that began in the Christmas exhibitions and was tried out at the same time in the Hexenhaus and the new furniture designs and exhibition stands created in conjunction with ТЕСТА.

The 'concealment and display' concept first tested in the 'House of the Future' in the 1950s was still present in the installation designed for the 'Twenty-Four Doors to Christmas' exhibition held in 1979. Behind the doors in this exhibition were a variety of boxes containing Christmas-themed displays of different types and origin, but thanks to orderly, anonymous style created by the cupboard-door metaphor, the inhabitant remained in pride of place. Peter Smithson described a similar idea in the article 'In Praise of Cupboard Doors' written in that same year of 1979: 'Cupboard doors are necessary to bring these miscellaneous things *to the right level of attention* amongst the thousands of things that surround us inside and outside the house.'¹²

That well-defined boundary between the exhibition room itself and the interior of each display, between the platform and the contents, began to break down into layers just one year later in the 'Christmas-Hogmanay' exhibition where outlines became blurred and morphed into meeting places instead of lines of separation. Among these layers of lattices, the architecture provided a receptive place for displays and decorations and particularly visitors, who 'are invited to decorate by being there: responsibility is returned to them for quality of use, for style of occupancy'.¹³ Visitors are active leading figures in a staged, Scottish landscape where they can look almost right through the exhibition from countless viewpoints that change as they move along and experience different layers that overlap and create an enshrouding atmosphere that awakens a myriad of sensations: expectancy, discovery, surprise,

10 David Robbins, *The Independent Group: Postwar Britain and the Aesthetics of Plenty* (MIT Press, 1990), p.129.

11 'In short it forms a poetic-lyrical order where images create a series of cross-relationships.' These were the last words in the exhibition press release prepared for the Institute of Contemporary Arts, dated August 31st 1953 and published in *October* n.136, Spring 2011, p.7. The parallel with the Hexenhaus porch is obvious.

12 Peter Smithson, 'In Praise of Cupboard Doors', *ILA&UD Yearbook 1979*, 40–41.

13 Smithson and Smithson, *The Charged Void: Architecture*, p.471.

seasons, etc. 'The Come Deck the Hall' exhibition took this disintegration one step further by simply providing visitors with some scaffolding to hang their decorations on and giving them the chance to play 'select and arrange' collectively for the first time. The resulting architecture was simply an enabling frame for the inhabitant because the quality of place depended solely on the quality of the patterns of use. There was no longer any room for concealment or boxes or cupboards.

A similar development happened in furniture design. The radical conceptual shift between the exhibitions 'Twenty-Four Doors to Christmas' (1979) and 'Christmas-Hogmanay' (1980) is similar to the transformation that occurred between the design of the His & Her Box shown at the '10 Years of Stefan Wewerka in TECTA' exhibition (1985), and the Collector's Table shown just one year later on the TECTA stand at the Milan International Furniture Fair (1986).

The His & Her Box – the first product of the Smithsons' partnership with TECTA – was a small cabinet (grey for him and red for her) for trinkets collected over the years. The items are stored but kept out of sight, thereby creating an orderly, anonymous style in keeping with the 'concealment and display' concept tried out previously with the Red Boxes for The Economist (1964) and the Ronald Jenkins' Cabinet (1952). The His & Her Box was the last piece of furniture in the Smithsons' period of 'boxes that conceal', a period followed by the new concept of 'boxes that display' featuring increasingly blurred edges: the Jewel Box (Alison Smithson, 1988), the Cornell Boxes (Alison Smithson, 1988), Struwelpeter's wallcabinet (Alison Smithson, 1986), etc.

The Collector's Table showcased at the Milan International Furniture Fair (1986) on the stand entitled 'The Future of Furniture. The Furniture of the Fourth Generation' was a good example of the new focus of the Smithsons' efforts. As Dirk van den Heuvel points out, this table was a celebration of the art of collecting able to maximise the inhabitant's self-expression by means of occupancy and objects.¹⁴ A place that was simply a structure for deploying the art of inhabitation, resulting in form – and colour too. The neutral, splatter-on-silver colour blended in with the background whilst highlighting the objects to be housed by the table. The focus of the concept shifted from concealment to display and the inhabitant's responsibility to 'select and arrange'. The 'box' vanished and became, in furniture design too, a framework in which the only centre-stage figure was the user.

From this point onwards furniture – and architecture – emerged as a framework able to extend the inhabitant's occupation or appropriation possibilities. An enabling frame for thinking, like the Waterlily/Fish Desk, or for enjoying plants even without a garden, like the Housegarden, or a scaffolding *for illusion and for activity* finally embodied by the porch.

Axel's Porch and the other projects at the Hexenhaus gradually broke down the boundaries and overcame the constraints of their inhabitation in order to engage occupiers in a game suggested by the architecture – a game designed to activate rather

14 Dirk van den Heuvel, 'Picking Up, Turning over and Putting With...', in *Alison and Peter Smithson - From the House of the Future to a House of Today*, 2004, pp. 12–28. (p.40).

than merely support their arts of inhabitation.

The Hexenhaus is the enabling frame of a collector, 'like the Eames House in California, this house is a collection in itself, plural and non-hierarchical.'¹⁵ The Hexenhaus forms a unique conglomerate together with its inhabitation: objects, decoration, furniture, landscape, weather, etc., are all inextricably bound together within the layering device as 'a permanent exhibition, stage and arrangement'¹⁶. Peter Smithson considered the Hexenhaus to be 'Axel's personal theatre', a stage whose meaning was provided by its usage and users, by the lifestyle created by its inhabitants.

A family of holes

These vanishing boundaries – that enable inhabitants to gaze into the remote distance and create overlapping images and intersecting views whilst incorporating the play of light and the seasons and unexpected encounters into the dialogue – were found not only at the interface between the interior and the exterior but in all spheres.

Alison suggested to Axel Bruchhäuser that openings could be made in the outer walls, inside partitions, the roof and even in the floor such as, for example, the triangles which were cut out of Wewerka's 'Stravinsky Boogie-Woogie' floor painting after he stopped working for ТЕСТА.¹⁷ These openings are all part of the family of Hexenhaus holes. Each hole defines a segment and frames a fragment, giving the user a new experience. The holes overlap and transform the user experience, making the house porous, permeable and complex.

Axel Bruchhäuser describes 'Let's make a hole'¹⁸ as one of the Smithsons' basic concepts during their close collaboration, a device they also tried out at the same time on the furniture designed in conjunction with ТЕСТА such as the M21 Table (1990) and particularly the Tischleindeckdich whose holes not only made the table lighter but were above all its distinguishing feature, a feature also used in the design of the 'Tischleindeckdich a.s.o.' exhibition invitation and catalogue.

Two holes in the form of windows on the first floor of the Hexenhaus were also the starting point of the 'On the Floor Off the Floor' exhibition. Whilst designing that exhibition, Peter Smithson built two windows overlooking the river Weser that were almost identical but in different positions that altered inhabitants' spatial perception and beckoned them to enjoy two different lifestyles: 'on the floor' thanks to a hole almost at floor level that lights the flooring and suggests a more laid-back lifestyle; and 'off the floor' in which a window above the desk lights the work area and suggests a more orderly life.

Holes, porches, annexes and other devices. All small but very intense projects that altered the house little by little over almost twenty years. The Hexenhaus gradually

15 Ibid, p.25.

16 Bruchhäuser, Axel (2015, May 14) [email to the author].

17 This was Alison's artistic answer to Wewerka's decision. Bruchhäuser, Axel (2015, April 16). [email to the author].

18 Bruchhäuser, Axel (2015, March 31). [email to the author].

opened up to embrace the outdoors, changing step by step, first under Alison's guidance and then Peter's, growing like a tree with roots descending into the earth and branches reaching skywards. Little by little the house appropriated itself of the territory and gradually blended in with the surrounding woods to form a single, indivisible whole, a built place in the 'as found' Grimm Brothers' fairy territory of Bad Karlshafen: an "ordinary" house, as Andrew Mead said, that became extraordinary.¹⁹

A calm cell in nature

The Hexenhaus represents life in perfect harmony with nature, and obviously echoes the allegory of the study of St Jerome. This house aims to be an idyll of inhabitation as portrayed in the Renaissance and baroque paintings of the life of Saint Jerome which Alison analysed in her essay *Hieronymus/Saint Jerome: The Desert, The Study*. By means of this short publication on display at ТЕСТА's stand at the Milan International Furniture Fair of 1991 together with a new version of the study of St Jerome portrayed in the famous painting of the same name by Antonello da Messina, Alison Smithson, in conjunction with ТЕСТА, presented the most human aspect of inhabitation in the design showcase of the world.

The preparation for that exhibition took place at the same time as the design of a tiny pavilion called the Hexenbesenraum (the witch's broom cupboard) also referred to as an 'energising cell' or 'restorative place in nature', another of Alison's projects at the Hexenhaus. Bruchhäuser commented on the Hexenbesenraum: 'If I am to survive as a modern businessman, I need a place like this – a place where I can recharge myself, away from the busy world.'²⁰

That tiny pavilion was a place of retreat tailored to cater for its user as a new interpretation of St Jerome's study which Alison designed down to the last detail. An example of an energising enabling frame presented as a 'restorative habitat for a future *light touch* inhabitation of the earth' in response to a society becoming more and more responsive to climate, nature and energy resources, and made possible by merging the old reciprocity generally portrayed in Renaissance paintings: the desert (nature) and the study (urban order).

Like St Jerome, Axel Bruchhäuser is a cultivated, thoughtful and creative man and a self-motivated scholar who remains himself in apartness. A man who does not like travelling and yet needs a peaceful place of retreat where he can think, away from all worldly concerns as Axel Bruchhäuser acknowledged on Andrew Mead's article 'Putting Down Roots': 'The Smithsons recognized that – it is the most wonderful gift from them. To take so serious charge for one person – for his soul – is unbelievable.'²¹ Alison used the allegory of the saint and his portraits to point out that 'whether in an urban setting or in nature, all creative activity relies on being cocooned. Such a sense of inviolability relies on its *fragment* of functional space being within an *enclave*

19 Andrew Mead, 'Putting Down Roots', *The Architects' journal*, 214 (2001), 26–35.

20 Ibid.

21 Ibid.

encapsulated in its turn within a protective territory.²²

Bruchhäuser, the Hexenbesenraum, the Hexenhaus, the woods, the Weser river, Bad Karlshafen... Stage and action merge into the whole of the territory and are complements necessary to achieve the idyll of inhabitation which Alison Smithson offers them. An idyll like the one the Smithsons themselves enjoyed at Upper Lawn until they were forced out in 1981 by very noisy neighbours who destroyed their sense of territory. At the Barcelona launch of the book about their Wiltshire home, Alison Smithson described 'the period in which they built, lived and made changes to the pavilion (1959-1982) as a period of "Jerome-ing"'.²³

In short, as Dirk van den Heuvel said, 'the Saint Jerome reference is of crucial importance. [...] Written and published toward the end of her life, Saint Jerome became the epitome of Alison's Smithson thoughts on inhabitation and her and Peter's notion of domesticity.'²⁴ Antonello da Messina's painting of *Saint Jerome in his Study* had already been used to illustrate the retrospective compilation of their earlier ideas *Ordinariness and Light: Urban Theories 1952-60 and Their Application in a Building Project 1963-70* in the chapter 'The Nature of Home; Its Equipment and Furniture' with the following caption: 'Nothing is more ordered than a bachelor's apartment'. The study of Saint Jerome represented the 'order' of 'ordinariness', a reference made even more eloquent by the following comment in the same book:

As architects it is the act of living that interests us – how we live – and furniture and how we dispose of it are only appurtenances of this act of living. [...]

*The possession of inviolable space is the individual's basic NECESSITY.*²⁵

Furniture as an extension of the actual user and the inherent need for a surrounding spatial territory are, therefore, two ideas that had already appeared alongside St Jerome (and the Smithsons) many years before they appeared at the Milan fair or were embodied as devices and decorations as part of the architecture of the Fourth Generation.

The air between

In the 1950s, the Smithsons were already echoing a patent necessity for an 'inviolable space' – surrounding air, void, territory and sky – originally linked to a symbol of identity, the inhabitant's re-identification. This was the era of the 'Patio & Pavilion' exhibition (a pavilion in a patio), the 'House of the Future' exhibition (a patio in a pavilion) and the private air diagrams (different ways of recording the sky in search of the last bastion of privacy).

Peter Smithson took a closer look at this concept twenty years later when he

22 Alison Smithson, *Hieronymus/Saint Jerome: The Desert, The Study* (Lauenförde: ТЕСТА, 1990).

23 Max Risselada, 'Another Shift', in *Alison and Peter Smithson – From the House of the Future to a House of Today*, 2004, pp. 50–58. (p.54).

24 Dirk van den Heuvel, 'Alison and Peter Smithson: A Brutalist Story, Involving the House, the City and the Everyday (plus a Couple of Other Things)', 2013. p.312.

25 Alison Smithson and Peter Smithson, *Ordinariness and Light: Urban Theories 1952-1960 and Their Application in a Building Project 1963-1970* (London: Faber and Faber, 1970). p.76.

opened the article entitled 'The Space Between' with the following words: 'The most mysterious, the most charged of architectural forms are those which capture the empty air [...]... such forms are double-acting, concentrating inwards, radiating buoyancy outwards.'²⁶ Moreover, the void fostered this inwards-outwards dual nature that enabled those involved to formally express themselves in a manner extending beyond its boundaries. The void not only endows buildings and users with self-esteem by acknowledging their inviolable space adherency or individual identity, but also allows them to work outwards, neutralising their individuality by blending them into an awareness of the 'space between', thereby contributing to the creation of a sense of belonging and human association.

Thirty years on, in the year 2000, Peter said, 'In the 1920s architects worked through housing. But I think the critical thing to work now is the space between.'²⁷ The history of modern architecture is the story of houses and domesticity and this is one of the most radical changes that modernism has contributed to architectural theory, but Peter Smithson identified the pressing need to look outwards again at its grouping because it was precisely in that mutual exchange that the real *raison d'être* of architecture was to be found. This statement made in the early twenty-first century defines the viewpoint held by Peter Smithson throughout his career, in all fields and on all scales ranging from the Doorn Manifesto (1954), in which dwellings and their groupings respond to the particularities of a given place, to the 'On the Floor Off the Floor' exhibition (1998) in which shadows reconstruct the object by means of the air around it, as in the case of Axel's Porch.

The porch can be read as an exemplar of a method by which a small physical change – a layering-over of air adhered to an existing fabric – can bring about a delicate tuning of the relationship of persons with place.²⁸

As Alison Smithson said shortly before her death, in an interview conducted by Clelia Tuscano, 'we rarely change our position, [...] we change the nuances'. Not only the porch but all the projects at the Hexenhaus were built on the basis of the surrounding air which became an atmosphere by absorbing the weather, seasons, light, etc., found in its own enclave. The Hexenhaus is a building of conglomerate ordering, a building experienced beyond the visual, 'developed from inside outwards, so that when it is materialised, our recognition of it is: "so that's what it looks like"... the conglomerate building'.²⁹ The exact balance between its filled areas and voids, the empooling of the space between shaping its user and its territory like the pebbles on the beach of a sandy shore, transforms it into a particular, unique and unrepeatable place.

26 Alison Smithson and Peter Smithson, 'The Space Between', *Oppositions*, n.4, (1974), 75–78.

27 Peter Smithson and Hans-Ulrich Obrist, *Smithson Time: A Dialogue* (Cologne: König, 2004). p.20.

28 Smithson and Smithson, *The Charged Void: Architecture*. p.552.

29 Smithson and Smithson, *Italian Thoughts*. p.69.

An unrepeatable pavilion for a unique inhabitant in a specific territory: 'This is one answer for the late eighties that I [Alison] spoke about first in Barcelona, 1985-1986; the calm cell in nature.'³⁰

An ensemble of ideas

The Hexenhaus with its paths, bridges, pavilions, porches, holes, etc., is a microcosm within the macrocosm that knitted the corpus of the Smithsons' work together in the last period of their career. The Hexenhaus is the melting pot of concepts stemming from the many different lines of research explored in exhibitions and seminars which, particularly after team 10 disbanded, became their new forum for discussion at ILL&UD (1976-2003), London (1976-1977), Delft (1982-1983), Munich (1984-1985) and Barcelona (1985-1986). But, like the flotillas in the 'Tischleindeckdich a.s.o.' exhibition, the Hexenhaus projects, despite their differences, formed an ensemble able to act spatially together in a new way: to stage the future of architecture.

This 'future' was based on a constellation of ideas: the 'lattice idea' in search of receptive architecture; the metaphors of St Jerome as a humanist idyll and Noah's Ark as the representation of a survival location, a collective lifestyle and ecology; 'conglomerate ordering', an all-embracing, open concept which, like the architecture it describes, gradually changes as time goes by; 'the space between' and the necessity of void and air; and, once again, the 'arts of inhabitation'.³¹

In this final period of their work, the Hexenhaus is a sort of intellectual testament, a final manifesto. Alison, now unfettered and at a time of intellectual maturity, created a new language that was to reflect an entirely new way of doing architecture – a legacy that Peter pursued and elaborated upon after her death, making it more intellectually complex. The fact that they could implement these new concepts immediately also gave them the opportunity to experiment with and think about what they were building. This in turn provided feedback and triggered off a refreshing dialogue that generated an endless source of inspiration, because new material to continue working was always found whilst working on their projects.

There is also an underthought persistence in the interplay between the 'ephemeral' and the 'permanent'; the graphic work and the built work intertwine in the 'interventions' in Bad Karlshafen. [...]

This process of allowing the 'idea-so-far' to be reflected on seems to be a parallel work process to 'place-response' urbanism: an urbanism in which what exists is re-assessed in the 'coming-into-being' of the work in hand; every work a new assessment, a new response to what is already there.³²

30 Marco Vidotto, *Alison + Peter Smithson. Obras Y Proyectos* (Barcelona: Ed. Gustavo Gili, 1997). p.204.

31 Max Risselada associate the work on the Hexenhaus (and for TECTA) with concepts such as "Conglomerate Ordering" and "The Lattice Idea", which imply a reconsideration of the idea of tectonics' and which 'on a more metaphorical level are summarized by their respective titles of "Noah's Ark Futures" and "Hieronymus/Saint Jerome: The Desert – The Study", to which the author of this paper would also add "The Space Between" and the "Arts of Inhabitation"'. (Max Risselada, 'Introduction', in *Alison & Peter Smithson: A Critical Anthology*, ed. by Max Risselada (Barcelona: Ediciones Polígrafa, 2011), pp. 18–35. (p.29).

32 'Set of Mind' Smithson and Smithson, *Italian Thoughts*. p.101.

In this experimentation – which finally allowed the Smithson to materialise, free of conventions, the ideas they had been developing since the early days of their careers in the 1950s and which also included the new concepts they had gradually developed – Axel Bruchhäuser's contribution was fundamental: as a patron, friend and inhabitant.

A man and his cat

During a conversation in 2000 between the curator Hans Ulrich Obrist and Peter Smithson, published under the title of *Smithson Time*, Peter explained how important a good patron is for architecture: 'you only get a good building when the patron has fallen in love with you, when he wants you [...] does not care if you make a mistake.' He wound up the interview by saying 'as an architect you might get four perfect patrons in your lifetime. We have found one and are working together as accomplices on a house and a factory.'

Axel Bruchhäuser was the only patron to cross the path of Alison and Peter Smithson, and it was by working with him that they were finally able to materialise the 'staging of the possible' that they had been developing whilst gradually renovating the Hexenhaus. The Smithsons were introduced to Bruchhäuser in 1980 by a mutual friend, Stefan Wewerka, who had been ТЕСТА's adviser since the early 1970s and had met the Smithsons at the Team 10 meetings. Wewerka was aware of the huge potential of an encounter between 'an enthusiast of Bauhaus design, and the two polemical architects, sacrilegious interpreters of the same school'.³³

Bruchhäuser, the Smithsons and Wewerka were outsiders in their different fields but they all had the same lifestyle and outlook on life. For each of them, theory and practice and life were tightly interwoven – an approach that Wewerka also suggested for the *Mobilmachung* magazine – into an indivisible whole. Communication between the Smithsons and Bruchhäuser quickly changed tack, moving beyond rational considerations and becoming so intense that, like the architecture of conglomerate ordering, it 'harnessed all the senses'. It manifested itself as an invisible force in a profound and close-knit relationship expressed playfully and very creatively in letters supposedly between Karlchen and Snuff (the pet cats belonging to Bruchhäuser and the Smithsons respectively), prompting a new dimension in their relationship from this point onwards. The letter in which Karlchen (Bruchhäuser) asked Snuff (the Smithsons) to build a Yellow Lookout in 1984 was quite simply an unconditional surrender – a 'declaration of love' that was to last almost twenty years.

Friendship was always a basic ingredient in the Smithsons' work. Their cooperation with Nigel Henderson and Eduardo Paolozzi arose from their initial friendship and affection after Peter Smithson and Eduardo Paolozzi met whilst teaching at the Central School, London. It was the celebration of this friendship that prompted them to take part in the meetings of the Independent Group and also to combine forces to hold two momentous exhibitions: 'Parallel of Life and Art' (1953) and 'Patio

33 Scimemi.

& Pavilion' (1956). Friendship was also a decisive factor as regards the meetings and members admitted to Team 10, a loose group whose history was based mainly on personal events and encounters. It was also their relationships with friends that guided them through academia: Giancarlo di Carlo at ILA&UD, Jaap Bakema and Max Risselada at TU Delft, Enric Miralles and Carme Pinós at ETSAB in Barcelona, Oswald Ungers at Cornell University, etc.

The friendship and unquestioning faith of a customer in love with his architect was also the foundation of Renaissance architecture, the mirror the Smithsons also resorted to when drawing parallels with the three generations of modernism. Their relationship with Bruchhäuser, however, went even further because they applied the same drive and determination as him when working in any area: the design of a piece of furniture, an exhibition, the refurbishment of his factory or even his own lifestyle. A simultaneous and combined effort in which extraordinarily strong empathy was always the key factor.

Peter Smithson explained how this way of working marked a U-turn in their life: 'from insights gained through building which, somehow, indicate what one should try to do next... to a new condition of becoming a servant of another's insights'.³⁴ As Axel Bruchhäuser said, 'the base of their cooperation was "step by step" and the permanent question was "Axel, what's next?"'³⁵

From this point onwards, construction and inhabitation went hand in hand. This modus operandi was quite different from their work, for example, on the 'Patio & Pavilion' exhibition when the Smithsons designed a framework inhabited subsequently by Henderson and Paolozzi, or the scaffolding designed to be occupied in 'Come Deck the Hall'. Every venture at the Hexenhaus was in response to a suggestion by Axel which was then interpreted and reworked by the Smithsons to ensure that each one gave what the other needed. In the case of the porch, for example, Axel originally asked for a completely open space overlooking the woods but the Smithsons responded with 'a layering-over of air'. Year after year Alison travelled to what she called the 'Hansel and Gretel house' to soak up the magic of that place that had bewitched her and share her comments and impressions with its inhabitant – always giving rise to more alterations.

Alison and Peter Smithson had at last found the patron who set this machinery in motion³⁶ and made it possible to experiment with architecture just as Rietveld

34 Peter Smithson, 'Being at Home', *ILA&UD Yearbook 1997*, 80–85.

35 Bruchhäuser, Axel (2015 May 14). [email to the author, 14-05-2015.

36 'The machinery of the person, the machinery of the activity, complement each other.' Words written by Alison Smithson alongside a photo of Jackson Pollock at work. (Alison and Peter Smithson Archive / ТЕСТА Archive Lauenförde).

The result of this symbiosis 'like a natural phenomenon, a manifestation rather than an artifact; complex, timeless, n-dimensional and multi-vocative' is the work of art. The result of this mutual understanding that also seems to be a natural phenomenon, a manifestation rather than an artifact, and so on, in the Hexenhaus is the expression par excellence of the arts of inhabitation: 'architecture as a direct statement of a way of life...'

Alison and Peter Smithson loved Jackson Pollock's paintings and particularly Pollock at work. After seeing an exhibition of Pollock's paintings at Peggy Guggenheim's palazzo in Venice in 1949, they often chose photos of Pollock at work to illustrate their publications. In this instance, Pollock illustrates their idea that 'people and objects in motion and change are both the stuff and decoration of the urban scene' (Smithson and Smithson, *Ordinariness and Light: Urban Theories 1952-1960 and Their Application in a Building Project 1963-1970*. p.86).

did with Truus Schröder-Schräder when building his greatest work. The Rietveld-Schröder house (1923) which the Smithsons so admired was, like the Hexenhaus, magical because 'it was the setting for a masque celebrating the arrival of a new style', a place 'where the owner was patroness, inspirer and joint-inventor'.³⁷

There is however a flaw in this comparison. Truus Schröder-Schräder was imagining the living arrangements for her house before the house was there. Her decisions were intellectual. Axel Bruchhäuser was imagining changes in his living experiences after living in the Hexenhaus for many years. His thoughts concerning extensions, light-sources, views out and so on were the consequence of his eye and his body in the circumstance of clima and light throughout the year. His decisions were corporeal.

Building, territory and inhabitant merge and blend together. A man and his cat, like St Jerome and his lion, in harmony with the woods, river, light, air and climate. The building listens carefully, interprets their needs and creates a new language able to heighten the communication between them. Their relationships extend beyond the visible world and involve all the senses, instincts and even the subconscious. Extraordinary sensations that call for extraordinary communications, like the sensory, magical 'ccw' (cat connection web) between Karlchen and Snuff that began in 1984 and enabled an extraordinary architecture to materialise.

The lota³⁸ on the river Weser

The article 'Signs of Occupancy' written originally in 1969 and published in the *Architectural Design* journal in February 1972, gave rise to the 1976 seminar at the Bartlett School of London, also called 'Signs of Occupancy', which marked the start of the Christmas exhibitions. In that article, Alison and Peter Smithson mentioned the Eameses' Ford Foundation report to the Indian government (1958) entitled 'What To Do About Design in India'.

'Of all the objects we have seen and admired during our visit to India, the lota, the simple vessel of everyday use, stands out as perhaps the greatest, the most beautiful - the village women have a process which, with the use of tamarind and ash, each day turns this brass into gold.

But how would one go about designing a lota?

First one would have to shut out all preconceived ideas on the subject and then begin to consider factor after factor:

The optimum amount of liquid to be fetched, carried, poured, and stored in a prescribed set of circumstances.

The size of strength and gender of the hands (if hands) that would manipulate it.

The way it is to be transported - head, hip, hand, basket, or cart.

The balance, the centre of gravity, when empty, when full, its balance when rotated for pouring. The fluid dynamics of the problem not only when pouring, but when filling and cleaning, and under the complicated motions of head carrying - slow and fast.

Its sculpture as it fits the palm of the hand, the curve of the hip.

37 Peter Smithson, 'The Masque and the Exhibition: Stages Towards the Real', *ILAC&UD Yearbook 1981*, 62-67.

38 Lota (from Hindi and Urdu *lotā*): typically a round, brass vessel for storing or carrying water.

Its sculpture as a complement to the rhythmic motion of walking or a static pose at the well.

The relation of opening to volume in terms of storage uses - and objects other than liquid.

The size of the opening and inner contour in terms of cleaning.

The texture inside and out in terms of cleaning and feeling.

Heat transfer - can it be grasped if the liquid is hot?

How pleasant does it feel, eyes closed, eyes open?

How pleasant does it sound when it strikes another vessel, is set down on ground or stone, empty or full - or being poured into?

What is the possible material?

What is its cost in terms of working?

What is its cost in terms of ultimate service?

What kind of an investment does the material provide, as product, as salvage?

How will the material affect the contents, etc., etc.?

How will it look as the sun reflects off its surface?

How does it feel to possess it, to sell it, to give it?

...no one man designed the lota, but many men over many generations. Many individuals represented in their own way through something they may have added or may have removed, or through some quality of which they are particularly aware.'

Interpreting Eames-form language sets up a dialogue between object and user. The object suggests how it can be used, the user responds by using it well - the object improves; or it is used badly - the object is degraded, the dialogue ceases.

The lota sums up the goal of the Smithsons' architecture perfectly. Their efforts focus firstly on striking up a dialogue between building and user (and between building and place: this is the 'as found') but the architecture then gradually disintegrates into a mere interface that enables persons to enter a relationship with place. A refreshing dialogue at every moment and every day in which all the parties involved are leading lights that nonetheless merge into an ensemble and lose their individuality. A never-ending and yet orderly process that suggests step by step how the building can be used, and users reactivate it by using it well. It suddenly becomes the architecture of conglomerate ordering. It seems natural; harnesses all the senses; has a special presence; has the capacity to absorb spontaneous additions, subtractions and technical modifications without disturbing the sense of order, indeed such changes enhance it. It can accept change and brings all our senses into play... and its ultimate aim was to achieve a receptive, dressable architecture open to interpretation *without itself being changed*.

'...an architecture to be continually first staged, then built...'³⁹ but always enjoyed by its inhabitants.

39 'Staging the Possible' Smithson and Smithson, *Italian Thoughts*, p.23.

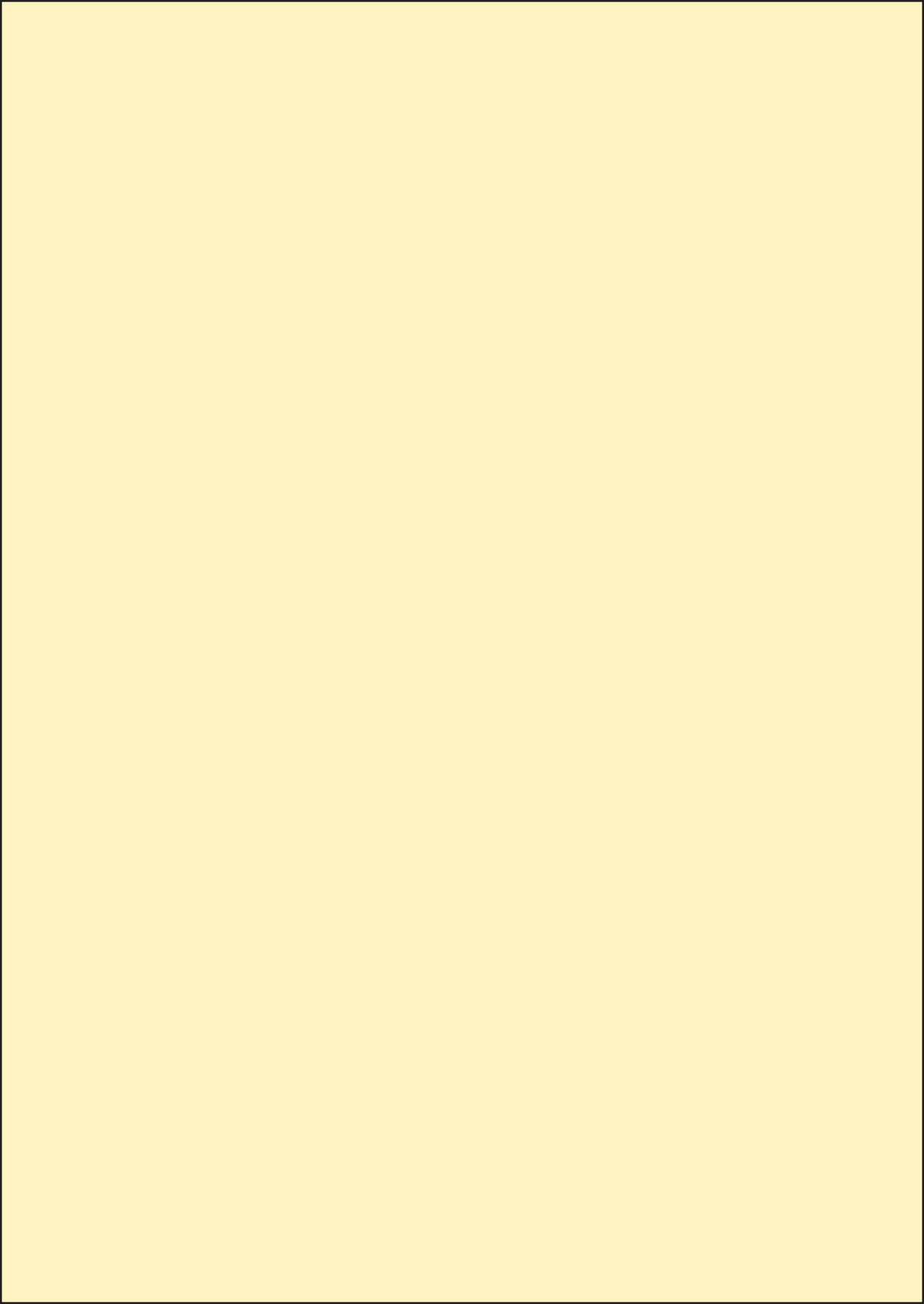

Sources and References

ALISON AND PETER SMITHSON ARCHIVES

Most of the materials and documentation on which the research submitted in this doctoral thesis is based comes from the three main archives dedicated to the work of Alison and Peter Smithson.

The Alison and Peter Smithson Archive: An Inventory. GSD Special Collections Department, Frances Loeb Library, Harvard Design School. (USA)

Alison and Peter Smithson Archiv / TECTA Archiv Lauenförde. (Germany)

Smithson Family Archive, Stamford. (United Kingdom)

BIBLIOGRAPHIES

For comprehensive bibliographies of the work of Alison and Peter Smithson, see:

Van den Heuvel, Dirk, and Max Risselada, eds., *Alison and Peter Smithson - From the House of the Future to a House of Today* (Rotterdam: 010 Publishers, 2004)

Risselada, Max, ed., *Alison and Peter Smithson: A Critical Anthology* (Barcelona: Ediciones Polígrafa, 2011)

Risselada, Max, and Dirk van den Heuvel, eds., *Team 10. In Search of a Utopia of the Present 1953-81* (Rotterdam: NAi Publishers, 2005)

Vidotto, Marco, A + P Smithson : *pensieri, progetti e frammenti fino al 1990* (Genova: Sagep, 1991)

Webster, Helena, ed., *Modernism without Rhetoric: Essays on the Work of Alison and Peter Smithson* (London: Academy Editions, 1997)

BIBLIOGRAPHICAL REFERENCES

Books published by Alison and Peter Smithson

Smithson, Alison, *As in Ds: An Eye on the Road*, ed. by Christian Sumi (Delft University Press, 1983)

—, ed., *The Emergence of Team 10 Out of C.I.A.M.: Documents*, AAGS Theory and History Papers (London: Architectural Association, 1982)

—, *Hieronymus/Saint Jerome: The Desert, The Study* (Lauenförde: TECTA, 1990)

—, *Imprint of India* (London:

Architectural Association, 1994)

—, *A Portrait of the Female Mind as a Young Girl* (London: Chatto & Windus, 1966)

—, *Team 10 Meetings 1953-1984* (New York: Rizzoli, 1991)

—, ed., *Team 10 Primer* (Kent: Whitefriars Press, 1965)

—, ed., *Team 10 Primer* (Cambridge: MIT Press, 1968)

Smithson, Alison, and Peter Smithson, *The 1930's* (Berlin: Alexander Verlag, 1985)

—, *Alison + Peter Smithson: The Shift*, ed. by David Dunster, Architectural Monographs no.7 (London: Academy Editions, 1982)

—, *Cambiando El Arte de Habitar: Piezas de Mies, Sueños de Los Eames, Los Smithsons* (Barcelona: Ed. Gustavo Gili, 2001)

—, *The Charged Void: Architecture* (New York: Monacelli Press, 2001)

—, *The Charged Void: Urbanism* (New York: Monacelli Press, 2005)

—, *The Euston Arch and the Growth of the London, Midland & Scottish Railway* (London: Thames & Hudson, 1968)

—, *The Heroic Period of Modern Architecture* (New York: Rizzoli, 1981)

—, *Italian Thoughts* (Stockholm, 1993)

—, *Ordinariness and Light: Urban Theories 1952-1960 and Their Application in a Building Project 1963-1970* (London: Faber and Faber, 1970)

—, *Upper Lawn: Folly Solar Pavillion*, Arquitectura I Urbanisme (Universitat Politècnica de Catalunya, 1986)

—, *Urban Structuring: Studies of Alison & Peter Smithson*, A Studio Vista/Reinhold Art Paperback (London: Studio Vista, 1967)

—, *Without Rhetoric: An Architectural Aesthetic, 1955-1972* (London: Latimer New Dimensions, 1973)

Smithson, Alison, and Peter Smithson, *St. Hilda's College, Oxford: La Arquitectura Del Entramado*, ed. by Aquiles González and Marco Vidotto, Arquitecturas Silenciosas (Colegio Oficial de Arquitectos de Madrid, 2001)

Smithson, Peter, and Karl Unglaub, *Flying Furniture: Unsere Architektur Rollt, Schwimmt, Fliegt = Our Architecture Rolls, Swims, Flies* (Cologne: König, 1999)

Selected essays by Alison and Peter Smithson

Smithson, Alison, '24 Doors to Christmas', *Architectural Design*,

November-December (1980), 177-78

—, 'And Now Dhamas Are Dying out in Japan', *Architectural Design*, September (1966), 447-48

—, 'Beatrix Potter's Places', *Architectural Design*, December (1967), 573

—, 'Collective Design: Collective Quality', *Architectural Design*, November (1974), 719-21

—, 'Collective Design: The Good-Tempered Gas Man', *Architectural Design*, March (1975), 163-68

—, 'The Future of Furniture', *Architectural Design*, April (1958), 175-78

—, 'The Garden of Eden, Lower East Side Manhattan', *Spazio e Società*, December (1984), 60-77

—, 'Into the Air', *MASS. Journal of the School of Architecture and Planning*, VII (1989), 7-10

—, 'Louis Kahn: Invitation to Otterloo', *Arquitecturas bis*, 41-42 (1982), 62-63

—, 'My Kind of Town', *Architecture Today*, May (1990), 88

—, 'Not Quite Architecture: Report on Christmas I', *The Architects' Journal*, 139 (1964)

—, 'Reappraisal of Concepts on Urbanism', *Architectural Design*, July (1974), 403-6

—, 'Strati E Stratificazioni / Layers and Layering', *Spazio e Società*, n. 13 (1981), 96-100

—, 'Sulla Trama Del Movimento Moderno', *Spazio e Società*, n. 20 (1982), 74-83

—, 'The Violent Consumer, or Waiting for the Goodies', *Architectural Design*, May (1974), 274-78

Smithson, Alison, and Peter Smithson, 'An Alternative to the Garden City Idea', *Architectural Design*, July (1956), 229-31

—, 'The Appliance House', *Architectural Design*, April (1958), 177

—, 'The Built World: Urban Re-identification', *Architectural Design*, June (1955), 185-188

—, 'But Today We Collect Ads', *Ark*, 18 (1956)

—, 'Ciam Team 10' *Architectural Design*, May (1960) 175-185

—, 'Cluster City: A New Shape for the Community', *Architectural Review*, November (1957), 333-36

—, 'Concealment and Display: Meditations on Braun', *Architectural Design*, July (1966), 362-63

—, 'Density, Interval and Measure', *Architectural Design*, September (1967), 428-29

—, 'Eames Celebration: A Special Number on the Work of Charles and Ray Eames', *Architectural Design*, September (1966)

—, 'House of the Future at the Ideal

Homes Exhibition' *Architectural Design*, March (1956) 101-102
 —, 'House of the Future: Ultra-Automatic Design for 'Ideal Home' Exhibition' *The Architects' Journal*, March (1956) 232,236-237
 —, 'Mobility: Road Systems', *Architectural Design*, October (1958), 385-88
 —, 'Signs of Occupancy', *Architectural Design*, February (1972), 91-97
 —, 'The Heroic Period of Modern Architecture', *Architectural Design*, December (1965)
 —, 'The Nature of Retreat', *Places*, 7 (1991), 8-23
 —, 'The Pavilion and the Route' *Architectural Design*, March (1965) 143-146
 —, 'La Qualità Dell'ambiente', *Spazio e Società*, January (1978), 9-26
 —, 'The Space Between', *Oppositions*, n. 4 (1974), 75-78
 —, 'Thirty Years of Thoughts on the House and Housing', in *Architecture in an Age of Scepticism*, ed. by Denys Lasdun (New York: Oxford University Press, 1984), pp. 172-91
 —, 'Thoughts in Progress: The New Brutalism' *Architectural Design*, April (1957) 111-113
 —, 'Triennale Di Milano: Transformations of the City', *Architectural Design*, April (1968), 151
 —, 'Whither CIAM?' *Architectural Design*, October (1956) 343

Smithson, Peter, 'A&P Smithson', *Architectural Design*, July-August (1977), 528
 —, 'Being at Home', *ILA&UD Yearbook 1997*, 80-85
 —, 'Collective Design: Initiators and Successors', *Architectural Design*, October (1973), 621
 —, 'Conglomerate Ordering', *ILA&UD Yearbook 1986*, 54-59
 —, 'Empooling', *ILA&UD Yearbook 1996*, 42-45
 —, 'Fortifications', *ILA&UD Yearbook 1998*, 52-57
 —, 'In Miniature. O Little Town', *The Architects' Journal*, 17 (1998), 8-9
 —, 'In Praise of Cupboard Doors', *ILA&UD Yearbook 1979*, 40-41
 —, 'Inside Outside: Outside Inside', *ILA&UD Yearbook 2000*, 82-85
 —, 'Interactions and Transformations: Urban Structure and Urban Form', *Architectural Design*, January (1974), 38-40
 —, 'Just a Few Chairs and a House: An Essay on the Eames-Aesthetic', *Architectural Design*, September (1966), 443-46
 —, 'The Lattice Idea', *ILA&UD Yearbook 1999*, 58-61

—, 'Lightness of Touch', *Architectural Design*, June (1974), 377-78
 —, 'Making the Connection', *Architectural Design*, May (1975), 271-74
 —, 'The Masque and the Exhibition: Stages Towards the Real', *ILA&UD Yearbook 1981*, 62-67
 —, 'On the Edge', *ILA&UD Yearbook 1984*, 60-63
 —, 'Parallel Inventions', *ILA&UD Yearbook 1982*, 46-51
 —, 'Particularity: More Praise of Cupboard Doors', *ILA&UD Yearbook 1993*, 20-26
 —, 'Restaging the Possible', *ILA&UD Yearbook 1995*, 42-49
 —, 'Risking More to the Future: Some Further Thoughts on Connection; Concerning Narrative and Change of Organisational Base', *ILA&UD Yearbook 1977*, 163
 —, 'The Rocket', *Architectural Design*, July (1965), 322-323
 —, 'Sky', *ILA&UD Yearbook 1994*, 1, 48-49
 —, 'Some Further Layers: Work and Insights', *ILA&UD Yearbook 1978*, 78-79
 —, 'Three Generations', *ILA&UD Yearbook 1980*, 88-95
 —, 'Toy Towns ... Cradles of Authenticity', in *La Ville en Jeux / Toy Town (exhibition catalogue)* (Montreal: Canadian Centre for Architecture, 1997), pp. 7-14
 —, 'A Water-Biennale Park in the North of S. Elena', *ILA&UD Yearbook 1997*, 162-63
 —, 'Without rhetoric', *Architectural Design*, January (1967) 38-39

Other documents by Alison and Peter Smithson

Smithson, Alison, *An Anthology of Christmas, 1979*
 —, *Calendar of Christmas* (London, 1976)
 —, *The Christmas Tree* (London, 1976)
 —, *Christmas Hogmanay Exhibition (exhibition catalogue)* (Edinburgh: Scottish Arts Council, 1980)
 —, *A History of Layers and Layering, 1980*
 —, *Parallel of Life and Art (exhibition catalogue)*, 1953
 —, *Three pavilions of the third quarter of the 20th Century*, lecture recorded at Universitat Politècnica de Catalunya (1 January 1985) <<https://upcommons.upc.edu/handle/2099.2/469>> [accessed 7 April 2015]
 —, *Tischleindeckdich (exhibition*

catalogue), 1993

Smithson, Alison, and Jeremy Lewison, *Twenty Four Doors to Christmas: Aspects of 24 Doors (exhibition catalogue)* (Cambridge: University of Cambridge, 1979)

Smithson, Alison, and Peter Smithson, *Signs of Occupancy* (Pidgeon Audio Visual., 1979)

Smithson, Peter, *On the Floor Off the Floor (exhibition catalogue)*, 1998

About Alison and Peter Smithson

Astragal, '24 doors to Christmas', *The Architects' Journal*, 12 December 1979.

Baker, Jeremy, 'A Smithson File', *Arena, Architectural Association Journal*, 81 (1966), 179-218

Banham, Reyner, and Peter Jay, 'Milky Way at the Tate', *The Architects' Journal*, 139 (1964), 950-52

Baykan, Günay, Alison Smithson, and Peter Smithson, 'Interview with Alison and Peter Smithson', *METU JFA*, 1989 (1989), 67-104

La Biennale di Venezia 1976 (exhibition catalogue), (Venice, 1976)

Boyer, M. Christine, 'Architectural Design and the Writings of Alison and Peter Smithson (1953-75)', in *Team 10. In Search of a Utopia of the Present 1953-81*, ed. by Max Risselada and Dirk van den Heuvel (Rotterdam: NAI Publishers), pp. 198-99

Cabello Arribas, Juan, 'Ensamblaje: Desde La Filmina de Patio&Pavilion', 2010 [unpublished dissertation]

Colomina, Beatriz, 'Couplings', *OASE*, 51 (1999), 22-33
 —, 'Friends of the Future: A Conversation with Peter Smithson', *October*, 2000
 —, 'Unbreathed Air', in *Alison and Peter Smithson - From the House of the Future to a House of Today*, 2004, pp. 30-49

Cook, Peter, 'Introduction: Forty London Architects', *Net*, 3 (1976)
 —, 'Regarding The Smithsons', *Architectural Review*, July (1982), 36-43

Crosby, Theo, 'Parallel of Life and Art. Exhibition at the Institute of Contemporary Art' *Architectural*

- Design*, October (1953) 297
- , 'This is Tomorrow' *Architectural Design*, September (1956) 302-304
- Faraldi, Caryll, 'No Title', *The Observer*, 9 December 1979
- Fernández Villalobos, Nieves, *Utopías Domésticas. La Casa Del Futuro de Alison y Peter Smithson* (Barcelona: Fundación Caja de Arquitectos, 2012)
- Gosling, Nigel, 'This Is Our Life', *The Observer*, 1964, p. 25
- Hailey, Charlie, 'Treillage d Space : Tuning Person and Place in the Porches of Alison and Peter Smithson', *Environment, space, place*, 2 (2010), 79–119
- Henderson, Nigel; Paolozzi, Eduardo; Smithson, Alison; Smithson, Peter, 'Parallel of Life and Art: Indications of a New Visual Order', *October*, 2011, 7
- Heneghan, Tom, 'Blood of Architecture Runs Thin', *Building Design*, July 23 (1976)
- Van den Heuvel, Dirk, 'Alison and Peter Smithson: A Brutalist Story, Involving the House, the City and the Everyday (plus a Couple of Other Things)', 2013 [unpublished dissertation]
- , 'Picking Up, Turning over and Putting With...', in *Alison and Peter Smithson - From the House of the Future to a House of Today*, 2004, pp. 12–28
- , ed., *Rearrangements : A Smithsons Celebration*, OASE n°51 (1999)
- , 'Une dynamique générative', *L'architecture d'aujourd'hui*, n° 344 (2003), 30-39
- Van den Heuvel, Dirk, and Max Risselada, eds., *Alison and Peter Smithson - From the House of the Future to a House of Today* (Rotterdam: 010 Publishers, 2004)
- Hirche, Mathias, *Tischleindeckdich Usw.!: Galerie Aedes Berlin* (Berlin, 1993)
- Jeffels, Michael, 'Shape of Things to Come', *The Architects' Journal*, 171 (1980)
- Johnson, Pamela, ed., *Architecture Is Not Made with the Brain. The Labour of Alison and Peter Smithson* (London: Architectural Association, 2005)
- Lichtenstein, Claude, and Thomas Schreggenberger, *As Found, the Discovery of the Ordinary: British Architecture and Art of The 1950s* (Lars Müller Publishers, 2001)
- Maki, Fumihiko; Hara, Hiroshi, 'Shinken-chiku Design Competition. Theme: A Style for the Year 2001', *The Japan Architect*, 1984, 37–40
- Mead, Andrew, 'Putting Down Roots', *The Architects' Journal*, 214 (2001), 26–35
- Melhuish, Clare, 'Time to Reassess Brutalist Legacy', *Building Design*, 1158 (1994), 18
- Melville, Robert, 'Gallery: Lost and Recovered', *Architectural Review*, CLIX (1976), 93–96
- Meyhöfer, Dirk, 'The Mystery of the Cupboard Doors. The Architects Alison and Peter Smithson' (Deutschlandfunk) (2014) <http://www.deutschlandfunk.de/architektur-vom-geheimnis-der-schranktuer.1247.de.html?dram:article_id=285106>
- Middleton, Robin, 'The Pursuit of Ordinariness: Garden Building Oxford', *Architectural Design*, February (1971), 77–85
- Miralles, Enric, 'The Answer', *OASE*, 51 (1999), 18
- , 'On the Trundling Turk', *Arquitectura COAM*, July (1992), 85–88
- 'The Novelty of Neutrality', *The Architects' Journal*, 25 (1955), 140
- Painting and Sculpture of a Decade '54-'64 (exhibition catalogue)*, (London: Tate Gallery, 1964)
- Quattordicesima Triennale di Milano (exhibition catalogue)*, (Milano: Centro DI, 1968)
- R., J., "'54-64' Mostra a Londra', *Domus*, 419 (1964), 53–56
- Risselada, Max, ed., *Alison and Peter Smithson: A Critical Anthology* (Barcelona: Ediciones Polígrafa, 2011)
- , 'Another Shift', in *Alison and Peter Smithson - From the House of the Future to a House of Today*, 2004, pp. 50–58
- , 'Introduction', in *Alison & Peter Smithson: A Critical Anthology*, ed. by Max Risselada (Barcelona: Ediciones Polígrafa, 2011), pp. 18–35
- , 'The Space Between', *OASE*, 51 (1999), 46–53
- Rowntree, Diana, 'Hanging Space', *The Guardian*, 1964, p. 9
- Schmitgerhans, Holger, 'Tischlein Deck Dich Usw...', *Architektur & Wohnen*, 1993, offprint
- Scimemi, Maddalena, 'Alison E Peter Smithson: La Hexenhaus', *Casabella*, 2004, 7–21
- Scott, Fred, 'It's Architecture Again!', *Architectural Design*, November (1976)
- Sergison, Jonathan, and Stephen Bates, 'Lessons Learnt from Alison and Peter Smithson', *L'Architecture d'Aujourd'hui*, 344 (2003), 74–81
- Smithson, Peter, and Hans-Ulrich Obrist, *Smithson Time: A Dialogue* (Cologne: König, 2004)
- Smithson, Peter, Catherine Spellman, and Karl Unglaub, *Peter Smithson: Conversations with Students* (Princeton Architectural Press, 2005)
- Smithson, Simon, 'Foreword: On Editing and Pruning', in *Alison & Peter Smithson: A Critical Anthology*, ed. by Max Risselada (Barcelona: Ediciones Polígrafa, 2011), pp. 14–17
- Soriano, Federico, and Alberto Nicolau, ed., 'Alison & Peter Smithson', *Arquitectura COAM*, 1992, 49–88
- 'Speciale XIV Triennale', *Interni. La Rivista dell'arrendamento*, 1968
- Stephenson, Andrew, 'Painting and Sculpture of a Decade '54-'64 Revisited', *Art History*, 35 (2012), 420–41
- 'Tischleindeckdich', *Kölner Stadt-Anzeiger* (Cologne, 15 January 1993)
- Triangle Artists' Workshop (catalogue)*, (New York, 1987)
- Tuscano, Clelia, 'You Need Sixty Years. Interview with Alison and Peter Smithson', in *Team 10. In Search of a Utopia of the Present 1953-81*, ed. by Max Risselada and Dirk van den Heuvel (Rotterdam: NAI Publishers, 2005), pp. 338–39
- Unglaub, Karl, 'Material Reconstructed', in *Alison & Peter Smithson: A Critical Anthology*, ed. by Max Risselada (Barcelona: Ediciones Polígrafa, 2011), pp. 384–91
- 'Verzaubert: "Tischleindeckdich" in Der Galerie Mautsch', *Kölner Stadt-Anzeiger* (Cologne, 26 January 1993)
- Vidotto, Marco, *A + P Smithson : pensieri, progetti e frammenti fino al*

- 1990 (Genova: Sagep, 1991)
 —, *Alison + Peter Smithson. Obras Y Proyectos* (Barcelona: Ed. Gustavo Gili, 1997)
 Vidotto, Marco, A + P Smithson, and Augusto Mazzini, *Alison + Peter Smithson Architects: A Celebratory Exhibition* (London: Docomomo UK, 1994)
- La Ville en Jeux / Toy Town (exhibition catalogue)* (Montreal: Canadian Centre for Architecture, 1997)
- Webster, Helena, ed., *Modernism without Rhetoric: Essays on the Work of Alison and Peter Smithson* (London: Academy Editions, 1997)
- Wigley, Mark, 'Alison and Peter Smithson - The Architects of the Void', in *Alison & Peter Smithson: A Critical Anthology*, ed. by Max Risselada (Barcelona: Ediciones Polígrafa, 2011), pp. 410–23
- WithFord, Frank, 'Christmas Remembered...', *Cambridge Evening News*, 10 December 1979
- Woodward, Christopher, 'Drawing the Smithsons', in *Alison & Peter Smithson: A Critical Anthology*, ed. by Max Risselada (Barcelona: Ediciones Polígrafa, 2011), pp. 258–67
- Wong, Lorenzo, and Peter Salter, eds., *Climate Register: Four Works by Alison & Peter Smithson* (London: Architectural Association, 1994)
- About exhibitions and architecture exhibitions
- Altshuler, Bruce, *Biennials and Beyond Exhibitions That Made Art History: 1962-2002* (London: Phaidon, 2013)
 —, *Salon to Biennial Exhibitions That Made Art History, Volume 1: 1863-1959* (London: Phaidon, 2008)
- Azara, Pedro, Carles Guri, and Joan Roig, *Architects on Stage: Stage and Exhibition Design in the 1990's* (Barcelona: Ed. Gustavo Gili, 2000)
- Bayer, Herbert, 'Aspects of Design of Exhibitions and Museums', *Curator: The Museum Journal*, 4 (1961), 257–88
- Belcher, Michael, *Organización Y Diseño de Exposiciones: Su Relación Con El Museo*, Biblioteconomía y Administración Cultural (Gijón: Ediciones Trea, 1994)
- Bergdoll, Barry, 'Curating History', *Journal of the Society of Architectural Historians*, 57 (1998), 257 + 366
- Blau, Eve, 'Curating Architecture With Architecture', *Log*, n. 20 (2010), 18–28
 —, 'Exhibiting Ideas', *Journal of the Society of Architectural Historians*, 57 (1998), 256+366
- Bois, Yve-Alain, Hal Foster, Benjamin H.D. Buchloh, and Rosalind Krauss, *Arte Desde 1900: Modernidad, Antimodernidad, Posmodernidad, Arte Contemporáneo* (Madrid: Ediciones Akal, 2006)
- Crosby, Theo, ed., *This is Tomorrow (exhibition catalogue)*, (London: Whitechapel Art Gallery, 1956) reed. 2010
- Di Carlo, Tina, 'Exhibitionism', *Log*, n. 20 (2010), 151–58
 —, 'Exhibitionism as Inquiry?', *OASE*, n 88 (2012), 38–42
- Carter, Jennifer, 'Architecture by Design: Exhibiting Architecture Architecturally', *MediaTropes*, 3 (2012), 28–51
 —, 'Editorial Introduction. Exhibitions as Media', *MediaTropes*, 3 (2012), i –
- Cohen, Jean-Louis, 'Exhibitionist Revisionism: Exposing Architectural History', *Journal of the Society of Architectural Historians*, 58 (1999), 316–25
 —, 'Mirror of Dreams', *Log*, n. 20 (2010), 11–18
 —, 'Models and the Exhibition of Architecture', in *The Art of Architecture Exhibitions*, ed. by Kristin Feireiss (Rotterdam: NAI Publishers, 2001), pp. 25–33
- Colomina, Beatriz, 'Mies's House: Exhibitionism and Collectionism', *2G Mies van der Rohe. Houses*, 2009, 4–21
- Diller, Elisabeth, and Scofidio, Ricardo, 'Blur Building' <<http://www.dsry.com/projects/blur-building>> [accessed 18 June 2015]
- Feireiss, Kristin, ed., *The Art of Architecture Exhibitions* (Rotterdam: NAI Publishers, 2001)
- Fernández, Luis Alonso, and Isabel María García Fernández, *Diseño de Exposiciones: Concepto, Instalación Y Montaje* (Madrid: Alianza, 2010)
- García Blanco, Ángela, *La Exposición, Un Medio de Comunicación, Arte Y Estética* (Madrid: Ediciones Akal, 1999)
- Van Gerrewey, Christophe, Geert Bekaert, and Véronique Patteeuw, "'Architecture Can't Help Exposing Itself' In Conversation with Geert Bekaert", *OASE*, n. 88 (2012), 108–12
- Van Gerrewey, Christophe, Tom Vandeputte, and Véronique Patteeuw, 'The Exhibition as Productive Space', *OASE*, n. 88 (2012), 1–4
- Laberge, Marie Éizabeth, 'Communiquer L'architecture Par Le Média Exposition', *MediaTropes*, 3 (2012), 82–108
- Lake, Francis, ed., *The Ideal Home Book 1956*, (London: Daily Mail Publication, 1956)
- Lootsma, Bart, 'Forgotten Worlds, Possible Worlds', in *The Art of Architecture Exhibitions*, ed. by Kristin Feireiss (Rotterdam: NAI Publishers, 2001), pp. 16–24
- Lugon, Olivier, 'Musées sans Murs et Document. La Spatialisation de La Photographie Dans Les Expositions Des Années 1950', *Revue de L'Art*, 175 (2012), 27–35
- Mariani, Alessandra, 'Pratiques Interactives et Immersives ; Pratiques Spatiales Critiques. La Réalité Augmentée de L'espace D'exposition', *MediaTropes*, 3 (2012), 52–81
- Mairesse, Françoise; Griener Hurley, Cecilia, 'Éléments D'expologie : Matériaux Pour Une Théorie Du Dispositif Muséal', *MediaTropes*, 3 (2012), 1–27
- Abbot Miller, 'From object to observer', *Eye Magazine*, 61 (Autumn 2006) <<http://www.eyemagazine.com/feature/article/from-object-to-observer>> [accessed 14 May 2015]
- Mueller, Marianne, 'The Exhibition as Social Ground', *OASE*, n. 88 (2012), 90–95
- Rashid, Hani, 'Installing Space', in *The Art of Architecture Exhibitions*, ed. by Kristin Feireiss (Rotterdam: NAI Publishers, 2001), pp. 34–41
- Ota, Kayoko, 'Curating as Architectural Practice', *Log*, n. 20 (2010), 141–50
- Puente, Moisés, *100 años. Pabellones de exposición*, (Barcelona: Ed. Gustavo Gili, 2000)
- Steierhoffer, Eszter, 'The Exhibitionary Complex of Architecture', *OASE*, n. 88 (2012), 5–13

Szacka, Léa-Catherine, 'The 1980 Architecture Biennale The Street as a Spatial and Representational Curating Device', *OASE*, n. 88 (2012), 14–25
Urbach, Henry, 'Exhibition as Atmosphere', *Log*, n. 20 (2010), 11–17

Zardini, Mirko, 'Exhibiting and Collecting Ideas: A Montreal Perspective', *Log*, n. 20 (2010), 77–84
—, 'Triennale Milano: "Il Grande Numero"', in *Team 10. In Search of a Utopia of the Present 1953-81*, ed. by Max Risselada and Dirk van den Heuvel (Rotterdam: NAI Publishers, 2005), p. 158-161

General Bibliography

Albrecht, Donald, ed., *The Work of Charles and Ray Eames: A Legacy of Invention* (New York: Harry N. Abrams Inc., 2005)

Banham, Reyner. *El Brutalismo en Arquitectura. ¿Ética o Estética?*, (Barcelona: Ed. Gustavo Gili, 1967)
—, *Los Ángeles. The Architecture of the Four Ecologies* (The Penguin Press, 1971)
—, 'The New Brutalism' *The Architectural Review*, December (1955) 355-362

Benjamin, Walter, *La Obra de Arte En La Época de Su Reproductibilidad Técnica* (México D.F.: Itaca, 1936)

Bernárdez, Carmen, 'Kurt Schwitters' in *Educatyssen* <http://www.educatyssen.org/capitulo_3_kurt_schwitters> [accessed 12 August 2014].

Borsi, Franco, *Architecture et Utopie* (Paris: Éditions Hazan, 1997)

Bruchhäuser, Axel, *Der Kragstuhl / The Cantilever Chair* (Berlin: Alexander Verlag, 1986)

Bruchhäuser, Axel and Christian Drescher, 'Asymmetric Chair B1, Stefan Wewerka, 1979' <<http://www.tecta.de/en/produkt/b1/#21/ts/furniture/chairs/>> [accessed 27 April 2015]

Colomina, Beatriz, 'Foreword', in *Neo-avant-garde and Postmodern in Britain and Beyond*, 2010, pp. 1–4
—, *Privacy and Publicity. Modern Architecture as Mass Media* (Cambridge: The MIT Press, 1994)

Colquhoun, Alan, *Modernidad Y Tradición Clásica* (Madrid: Ediciones

Júcar, 1991)
—, 'Postmodernism and Structuralism: A Retrospective Gance', *Assemblage*, 1988, 7–15
Crisnon, Mark, and Claire Zimmerman, eds., *Neo-Avant-Garde and Postmodern: Postwar Architecture in Britain and Beyond* (New Haven & London: The Yale Center for British Art and The Paul Mellon Centre for Studies in British Art, 2010)
—, 'Introduction: Neo-Avant-Garde and Postmodern in Britain and Beyond', in *Neo-avant-garde and Postmodern in Britain and Beyond* (New Haven & London: The Yale Center for British Art and The Paul Mellon Centre for Studies in British Art, 2010)

Eames, Charles, 'Mies van Der Rohe', *Arts & Architecture*, December (1947), 24–27

—, *¿Qué Es Una Casa? ¿Qué Es El Diseño?*, GG mínima (Barcelona: Gustavo Gili, 2007)

Evans, Robin, 'Figures, Doors and Passages', *Architectural Design*, April (1978), 267-278

García García, Francisco de Asís, 'El Crismón', *Revista Digital de Iconografía Medieval*, II (2010), 21–31

GmbH, Marta Herford, ed., *Der Entfesselte Blick / The Unfettered Gaze. The Rasch Brothers and Their Influence on Modern Architecture* (Tübingen: Ernst Wasmuth Verlag)

Goldhagen, Sarah W., and Réjean Legault, *Anxious Modernisms: Experimentation in Postwar Architectural Culture* (Cambridge: MIT Press, 2002)

Grimm, Jacob, and Wilhelm Grimm, *The Complete Grimm's Fairy Tales*, Knickerbocker Classics (MBI Publishing Company, 2013)
—, *Tischlein Deck Dich (With Colour Pictures by Fritz Kredel)* (Postdam: Struwwelpeter-Original-Verlag, 1991)

Hereu, Pere, Josep María Montaner, and Jordi Oliveras, eds., *Textos de Arquitectura de La Modernidad* (Madrid: Editorial Nerea, 1994)

van den Heuvel, Dirk, 'Team 10 at Cornell', in *Team 10. In Search of a Utopia of the Present 1953-81*, ed. by Max Risselada and Dirk van den Heuvel (Rotterdam: NAI Publishers, 2005), pp. 180–81

Hewett, Cecil A., *English Historic Carpentry* (Phillimore, 1980)

Hobsbawm, Eric, *Age of Extremes, the Short Twentieth Century 1914-1991*, (London: Michel Joseph Ltd., 1994)
Lathouri, Marina, 'Frame and Fragment: Visions for the Modern City', *AA Files*, 2005, 58–67

LeCorbusier, and Pierre Jeanneret, *Le Corbusier - Oeuvre Complète: 1910-1929 Vol 1*, ed. by Willy Boesiger and Max Bill (Les Editions d'architecture, 1966)

El Lissitzky, 'Theses on the PRON: From Painting to Architecture' (1920) <<http://thecharnelhouse.org/2013/09/16/pron/>> [accessed 18 January 2015]

Lichtenstein, Claude, and Thomas Schregenerberger, eds., *As Found. The Discovery of the Ordinary* (Zurich: Lars Müller Publishers, 2001)

'Making Ikot Cloth', Victoria and Albert Museum articles, <<http://www.vam.ac.uk/content/articles/m/album-with-nested-carousel18/>> [accessed 11 March 2015]

Martí Aris, Carles, 'El Arte y la Ciencia: Dos Modos de Hablar con el Mundo' in *La Cimbra y el Arco*, (Barcelona: Fundación Caja de Arquitectos, 2005), pp. 21-29

Massey, Anne, *The Independent Group. Modernism and Mass Culture in Britain* (Manchester: Manchester University Press, 1995)

Massey, Anne, and Gregor Muir, *Institute of Contemporary Arts: 1946-1968*, (London: Institute of Contemporary Arts, 2014)

Neuhart, John, and Marilyn Neuhart, eds., *Eames Design: The Work of the Office of Charles and Ray Eames* (New York: Abrams Books, 1989)

Nicolin, Paola, *Castelli Di Carte: La XIV Triennale Di Milano, 1968*, Città E Paesaggio (Quodlibet, 2011)

'Net, no.2' (London: Art Net Gallery, 1976)

'On the Floor Off the Floor', *Passagen* (Cologne, 1998)

Ott, Nicolaus, and Bernard Stein, eds., *In Memoriam Kongresshalle Berlin: Realistische Phantasien Über Die Zukunft Unserer Ruine: Ausstellung Vom 6.11.1980-17.1.1981* (Berlin: Aedes Galerie für Architektur und Raum, 1980)

Pedret, Annie (MIT), 'CIAM and the Emergence of TEAM 10 Thinking, 1945-1959', 2001 [unpublished dissertation]

'¿Qué es el Ikat?', Teixits Riera, <<http://teixitsriera.com/telas-mallorquinas/el-ikat-en-mallorca/>> [accessed 11 March 2015]

Reeh, Ute, *Reise* (Cologne: Ed. Hundertmark, 1999)

Risselada, Max, 'Making Plans for the Future', in *Team 10. In Search of a Utopia of the Present 1953-81*, ed. by Max Risselada and Dirk van den Heuvel (Rotterdam: NAI Publishers, 2005), pp. 228-31

Risselada, Max, and Dirk van den Heuvel, eds., *Team 10. In Search of a Utopia of the Present 1953-81* (Rotterdam: NAI Publishers, 2005)

Robbins, David, *The Independent Group: Postwar Britain and the Aesthetics of Plenty* (MIT Press, 1990)

Solà-Morales, Ignasi, 'Arquitectura y existencialismo' in *Diferencias. Topografía de la arquitectura contemporánea* (Barcelona: Editorial Gustavo Gili, 2003), pp. 43-60

St John Wilson, Colin, *The Other Tradition of Modern Architecture* (London: Black Dog Publishing, 2007)

Szacka, Léa-Catherine, 'Léa-Catherine Szacka in Conversation with Rem Koolhaas and Stefano de Martino', *OASE*, n. 94 (2015)

Venturi, Robert, Denise Scott-Brown, and Steven Izenour, *Learning From Las Vegas* (Cambridge: The MIT Press, 1972)

Vidotto, Marco, 'Traces of a Birth and a Sudden Murder: Team 10's Sienna Exhibition and Meeting', in *Team 10 - Keeping the Language of Modern Architecture Alive*, ed. by Max Risselada, Dirk van den Heuvel, and Gijs de Waal (Faculty of Architecture Delft, 2006), pp. 210-21

Viota, Paulino, 'El Vampiro Y El Criptólogo', in *En Torno a Peirce. Estudios Semióticos* (Barcelona: Associació d'Estudis Semiòtics de Barcelona, 1986), pp. 173-85

'Vitebsk, Suprematism and the "Proun" Works, 1919-21', Museum of Modern Art, <http://www.moma.org/collection/browse_results.php?criteria=0%3AAD%3AE%3A3569&page_number=1&template_

[id=6&sort_order=1§ion_id=T051360#skipToContent](#)> [accessed 16 January 2015]

Walker, Enrique, ed., *Lo Ordinario* (Barcelona: Ed. Gustavo Gili, 2010)

Walsh, Victoria, *Nigel Henderson. Parallel of Life and Art* (London: Thames & Hudson, 2001)

Wewerka, Stefan, ed., *1972-1982. Bericht Einer Deutschen Unternehmung* (Berlin: Alexander Verlag, 1983)

Zardini, Mirko, 'ILA&UD 1974-2004. Giancarlo De Carlo and the International Laboratory of Architecture and Urban Design', in *Team 10. In Search of a Utopia of the Present 1953-81*, ed. by Max Risselada and Dirk van den Heuvel (Rotterdam: NAI Publishers, 2005), pp. 216-17

Acknowledgements

Acknowledgements

Many people have been involved in this long process and without each one of them this doctoral thesis would never have been possible.

First and foremost, my most grateful thanks to Axel Bruchhäuser. His kindness, trust and willingness to help were crucial in enabling this research to be carried out. Besides allowing me to delve into the Alison and Peter Smithson Archive / ТЕСТА Archive at Lauenförde, the comments, explanations and memories he so generously shared provided the definitive stimulus for many of the thoughts reflected herein.

I am also extremely grateful to Simon and Soraya Smithson for giving me access to the priceless information they safeguard in the Smithson Family Archive and also for their encouragement and interest in my research.

I am particularly grateful to Inés Zalduendo, head of the main Smithson archive, 'The Alison and Peter Smithson Archive: An Inventory' in the Special Collections Department of the Frances Loeb Library at Harvard, for her kindness and for always doing everything possible to make my visits to the archive as pleasant and productive as possible.

I am very grateful to Marco Vidotto, Max Risselada, Jeremy Lewison, Bengt Adlers, Nieves Fernández Villalobos, Victoria Walsh and Claire Zimmerman for their help in my searches. My thanks also to the staff at the different institutions I have been in touch with for their help in gathering information, particularly Tommaso Tonafetti at the Archive of the Fondazione La Triennale di Milano; Stacy Boldrick at The Fruitmarket Gallery; Luis Rego at the Bartlett School of Architecture; and Alex Fialho at the Triangle Arts Association.

I owe a very special thank you to my two thesis supervisors: Dirk van den Heuvel and Débora Domingo Calabuig. Dirk is one of the researchers I admire most and when he agreed to get involved in this process, it was like a dream come true. In addition, since our first meeting in Delft, his useful insights, approachable nature and trust have been crucial to the development of this thesis. Débora was the person who infected me with her love of these 'rough' architectures in her doctorate classes and since then she has been my constant guide. Without her advice, determination, energy, unbounded enthusiasm and ability to excite those around her, this research would never have been completed.

I particularly appreciate the help received from Anne Barton de Mayor, not only for

her fine English translation, but also for her very useful suggestions and comments.

Thank you to Teresa Corbín for her help, encouragement and support whilst this work was under way.

Thank you to Rafa Albert and Carlos Rivera for helping me understand German.

Thank you to Ana and Miguel for providing a place of retreat when I needed one for different reasons.

Many thanks to my family for trying to understand the incomprehensible, particularly my mother for her unconditional support and my brothers; and of course to Julia who arrived half way through and had to tolerate my absences without really understanding why.

My final and most special thanks is to my unfailing partner Pablo Llopis Fernández who has accompanied me every step of the way. I have shared and clarified all my ideas with him and he has generously offered valuable comments in return. With infinite patience he has accepted and made up for my absences every day, and also raised my spirits and encouraged me when my strength failed in difficult moments. The completion of this thesis is a special achievement which we share.

