

## **Experimental and design loads of pressure of bulk materials against silo wall**

Mieczysław KAMINSKI\*, Marek MAJ<sup>a</sup>

\*Institute of Civil Engineering Technical University of Wrocław, Poland,  
mieczyslaw.kaminski@pwr.wroc.pl

<sup>a</sup> Institute of Civil Engineering Technical University of Wrocław, Poland,  
marek.maj@pwr.wroc.pl

### **Abstract**

These investigations were carried out on silo models, free-standing silos and silo batteries. The researches include the evaluation of value of pressure and temperature field on the silo wall as well as temperature gradient, registration of simultaneity of these loads.

There were used sensors placed in the silo wall and bottom and sensors placed into material as sounder. The researches include either the evaluation of influences of the strength parameters of wall. Each of these investigated parameters is a random variable. Collection of such data as pressure, temperature, strengthen coefficients is of great significance, so the authors measured these loads many times. There is the need of calculation such quantities of statistics as characteristic, design value of measured loads and strength parameters, material and loads coefficient partial coefficient of safety, reliability indexes etc. These data were subjected to statistical accounts. The data obtained from calculations can be used in designing similar silos and in silo codes [1].

**Keywords:** silo, pressure, measurement, experiment, temperature, reliability

### **1. Introduction**

In general, two methods to determine bulk material pressures can be used, namely, the indirect and direct method. The indirect method consists of determining the strains in the silo structure, for example on the concrete surface or on the hoop reinforcing. But obtained in this way the tensile strains are very difficult to interpret in view of thermal, dynamic influence. Therefore, the above mentioned inadequacies of the indirect method have led to direct pressure investigations. The direct method was based on pneumatic, dynamometer, bonded wire strain gauge (used in '70 and '80), magneto elasticity sensors. The short history of development of this sensor constructions is described in [5,7]. One of the most applied pressure sensor, works on principle magneto elastic, was invented by research team [2] in '80 and '90 is shown in Fig. 1. The sensors are placed in the silo wall and bottom or during silo realization or they are exchanged during duration of experiment (Fig. 2, 4). This sensors has diameter about 17 cm when they are placed in walls and diameter about 25 cm when they are placed in bottom. Fig. 3 shows the results of pressure against wall.

They were used for measuring pressure and temperature. The same magneto-elastic principle was used in construction of another sensor, which works as sounder. The gauge

which looks like a disk, 30 cm in diameter and 1,5 cm thick (Fig.5) [3,4,5]. The pressure exerted by bulk solid on the gauge dipped in it. The gauge was suspended on a steel line fixed to the silo ceiling. They were used for measuring pressure and temperature against silo wall on fly ash (Fig. 6, 10) , flour, coal (Fig. 11, 12), gypsum (Fig. 11, 13), copper concentrate (Fig. 11, 13), cement (Fig. 2, 3), wheat (Fig. 9), rape silo (Fig. 7,8,10). Another, smaller sensors and sounders (5 cm in diameter, Fig. 15,16) were used on silo models. (Fig 15,17). This sensors were used in investigations of pressure in full scale silo and model silo on rape silos with pipe elements for reduction of pressure (Fig.7,17). Some results of horizontal pressure  $p_h$  for silos with diameter  $D$  are shown on Fig 3,10,12,13,14. They are described by using non dimensional coefficient  $\alpha$ ,  $p_h = \alpha \cdot \gamma_s \cdot D$ ,  $\gamma_s$  is specific weight. Comparisons of coefficient  $\alpha$  for this measured materials due European Code are presented on Fig. 21

## 2. Acting loads on silo construction.

The following equation must be fulfilled with regard to the reliability requirement:

$$S_G \leq R_G \text{ or } Z = R_G - S_G \geq 0 \quad (1)$$

There are loads  $S_G$  acting against silo construction (characterized by  $R_G$ ), such as material pressure  $p_h$ , pressure of aeration and homogenisation, temperature gradient across the silo wall  $\Delta T$ , temperature field on the silo wall caused by storage grain  $T$ , insolation and daily temperature variation, displacement caused by, for example, shrinkage, loads caused by post tensions, and other as concentrated loads, such as patch loadings, loads caused by eccentricity of discharging material etc. From these loads only pressure of material  $p_h$ , temperature  $T$  and  $\Delta T$ , wind loads are measurable, and only some aspects of this loads. Strength  $R_G$  of silo construction, is characterized by such parameters as: steel and concrete, strength, cover, diameter of bars, quantity of reinforced horizontal and vertical bars, adhesion of bars to concrete, quality of lap splices, type and quality of wall strengthening, openings in the silo wall, imperfections, cracks, condition of bars taking into account corrosion, technical condition of concrete, i.e. carbonisation, etc.

## 3. Determination of safety for the silo structure

Limit state equation (1) includes parameters of design values:

$$S_G = \sum_i (t_{mi} S_{xi,k}) \quad (2)$$

$$R_G = \sum_i (\gamma_{mi} R_{xi,k}) \quad (3)$$

where  $t_{mi}$  and  $\gamma_{mi}$  are load and resistance factors, respectively and  $S_{xi,k}$   $R_{xi,k}$  are components of loads and strength of silo construction,  $S_G$  – denotes multi componential action effects, that is, for example, force in horizontal reinforced bars in case of wall strength, is a function of many parameters as: pressure, temperature gradient across the silo wall  $\Delta T$  ect,  $R_G$  – is the resistance, i.e. concrete and bar strength in the case of wall strength, index “k” significa characteristic values. In order to estimate global safety factor  $\varpi$  - it is suitable to use characteristic parameter values  $S_{xi,k}$  and  $R_{xi,k}$ :

$$\varpi S_G^k \leq R_G^k \quad (5)$$

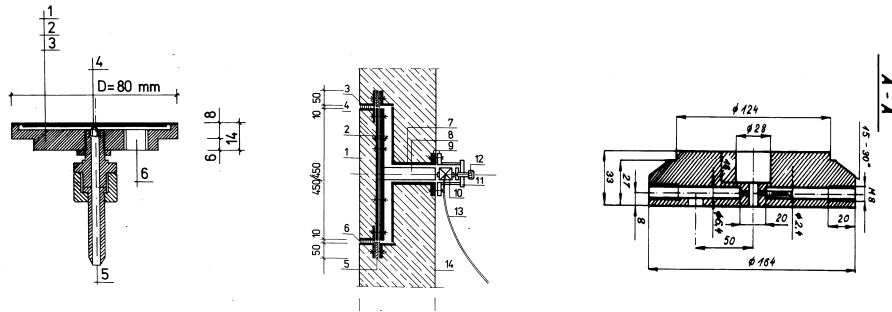

Fig. 1 Sensors construction based on pneumatic, dynamometer, magneto elastic phenomena used during pressure and temperature measurements

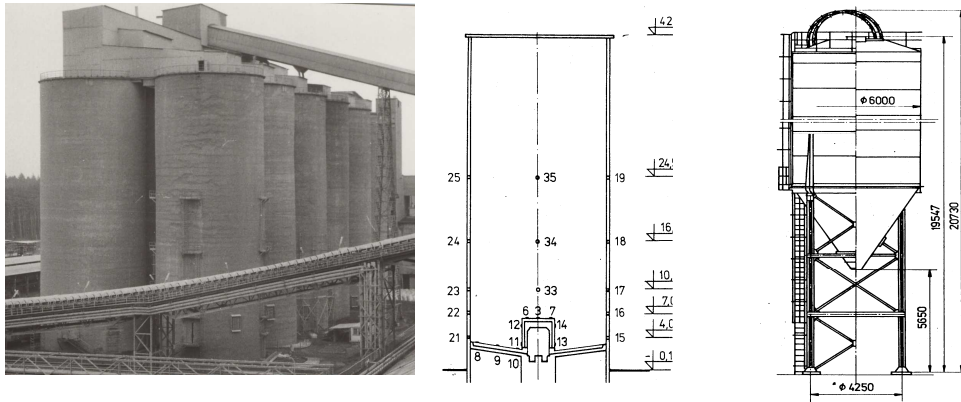

Fig. 2 Research of silos for cement

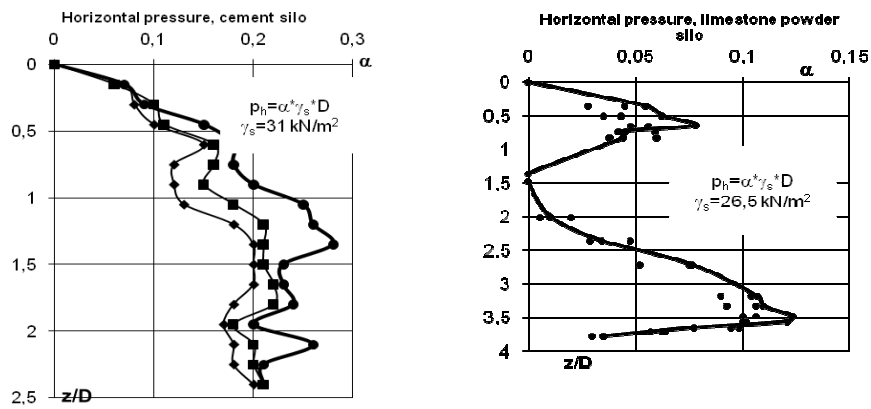

Fig. 3 Horizontal pressure against silo walls

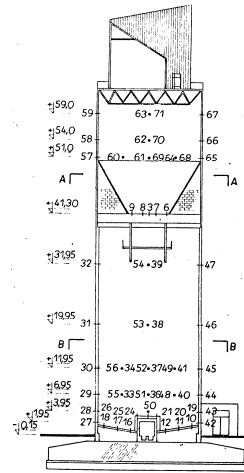

Fig. 4 Research of silo for limestone powder

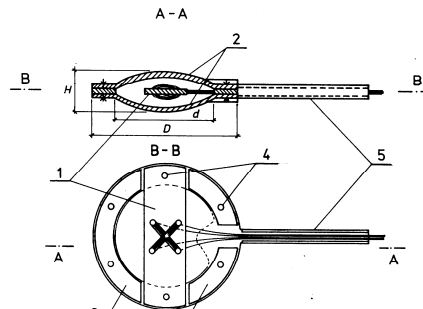

Fig. 5 Sounder sensor design by Borcz A.

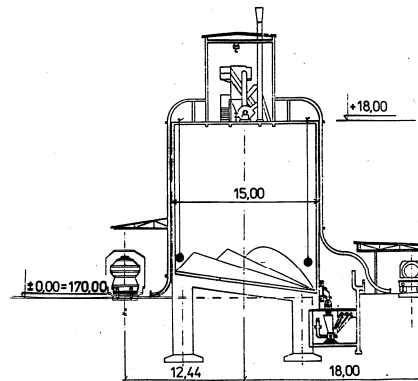
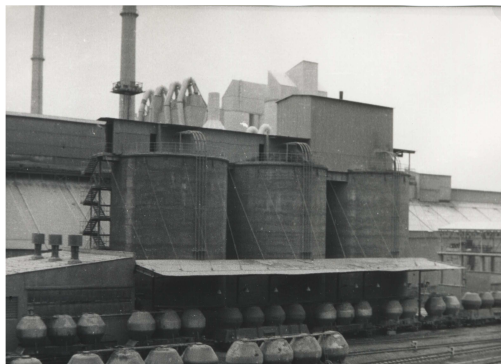

Fig. 6 Measuring of pressure on fly ash silo

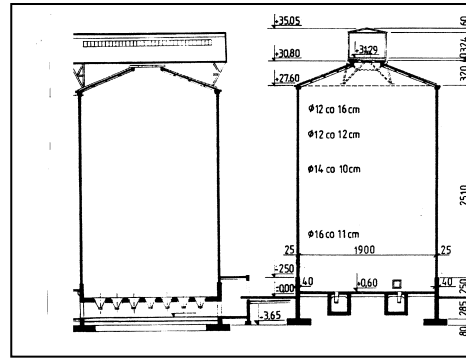

Fig. 7 Measuring of pressure on rape concrete silo

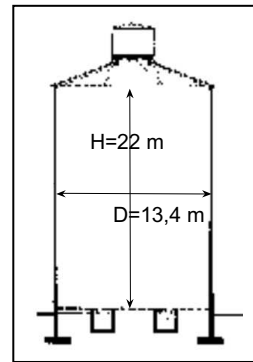

Fig. 8 Measuring of pressure on rape ceramic silo

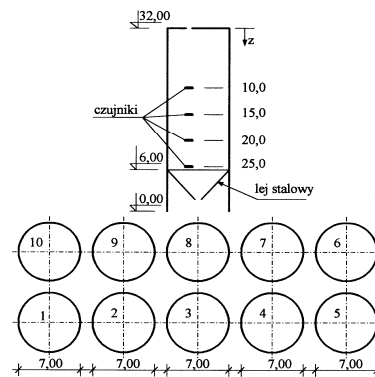

Fig. 9 Measuring of pressure on wheat silo

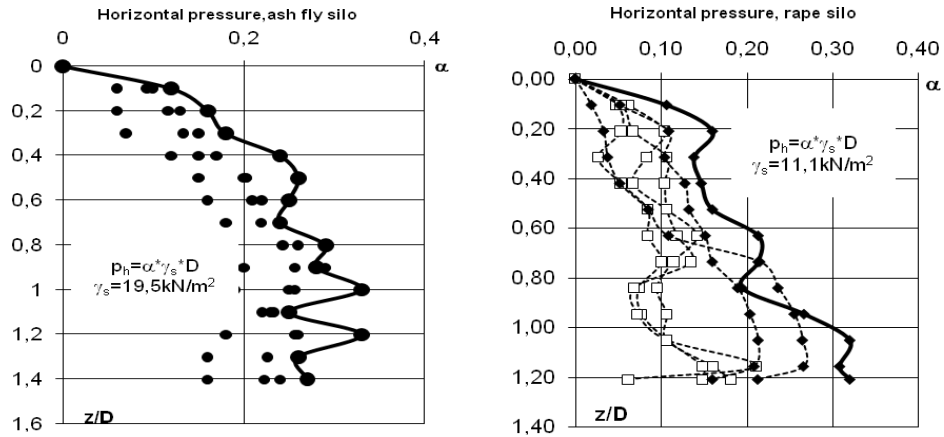

Fig. 10 Horizontal pressure against silo walls

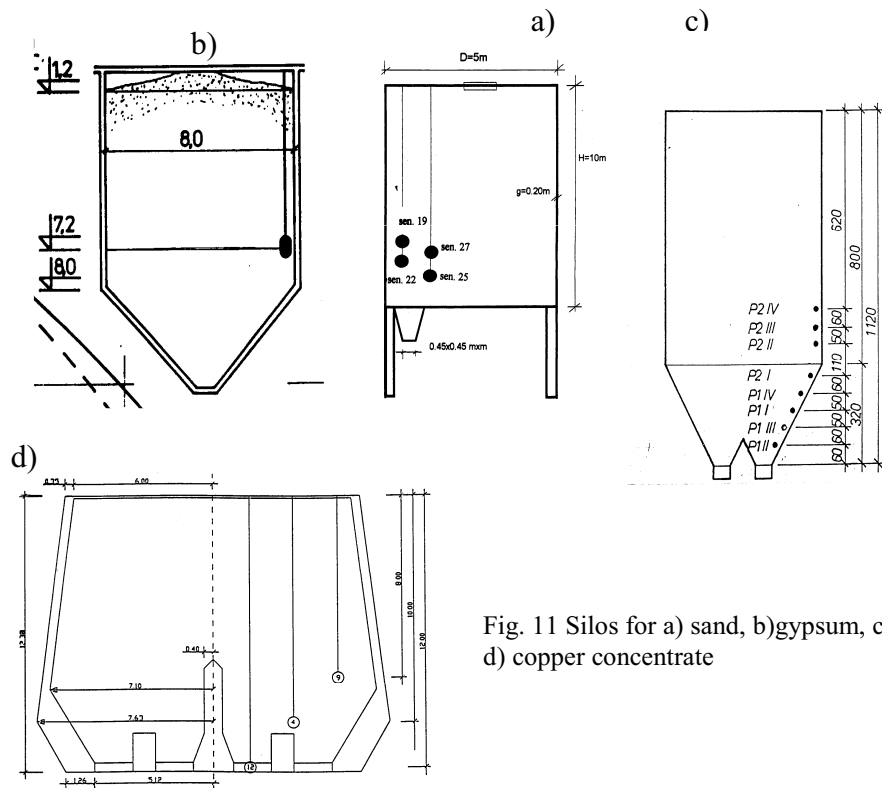

Fig. 11 Silos for a) sand, b) gypsum, c) coal, d) copper concentrate

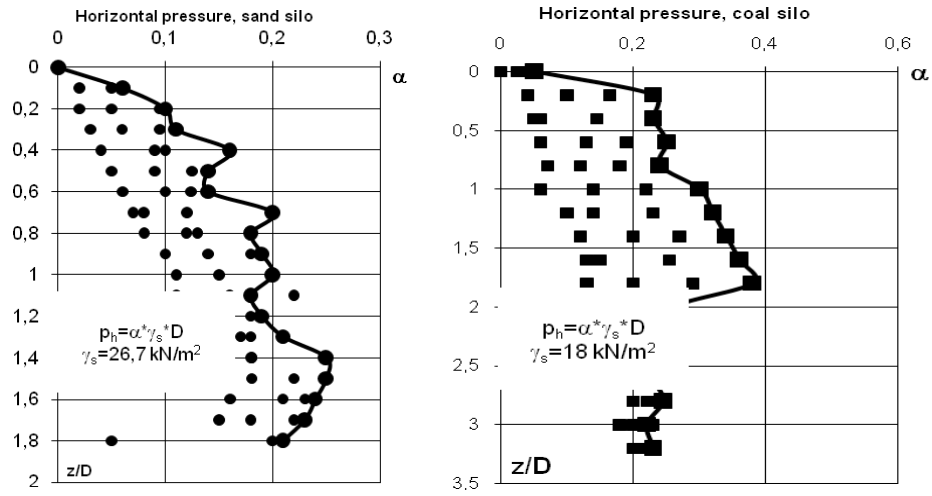

Fig. 12 Horizontal pressure against silo walls

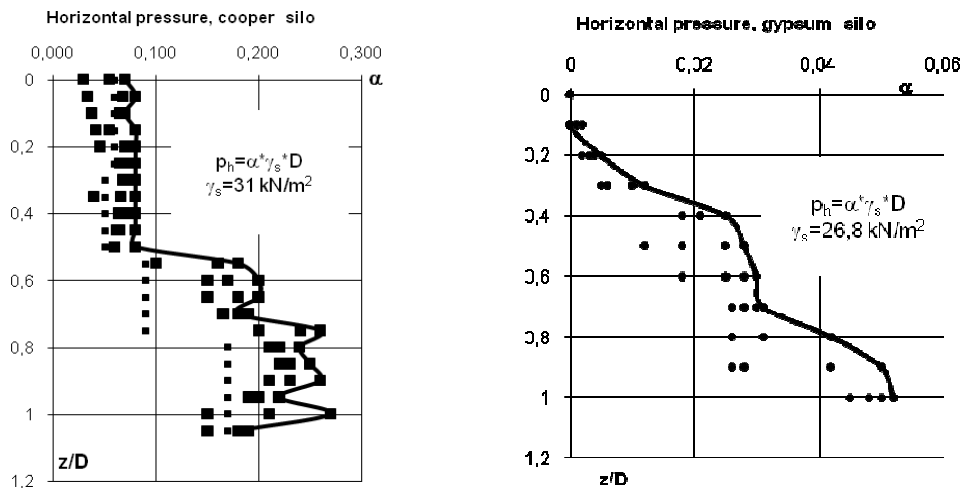

Fig.13 Horizontal pressure against silo walls



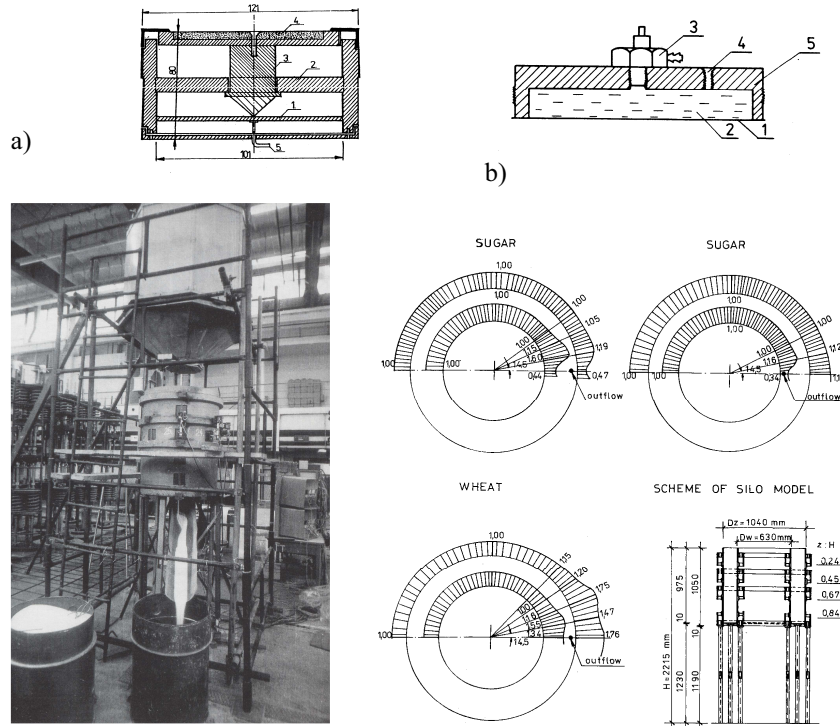

Fig. 14 Model of silo for sugar, sensors of Kaminski and Zubrzycki [7] functioning on the base a) electric resistance tensometer b) oil layer - pressure converter and some results of pressure

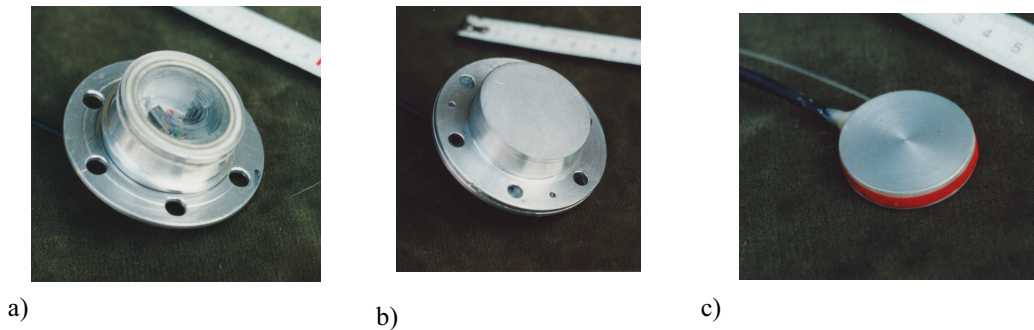

Fig. 15 View of sensors used in models a) for friction forces b) for horizontal and vertical pressure c) sounder



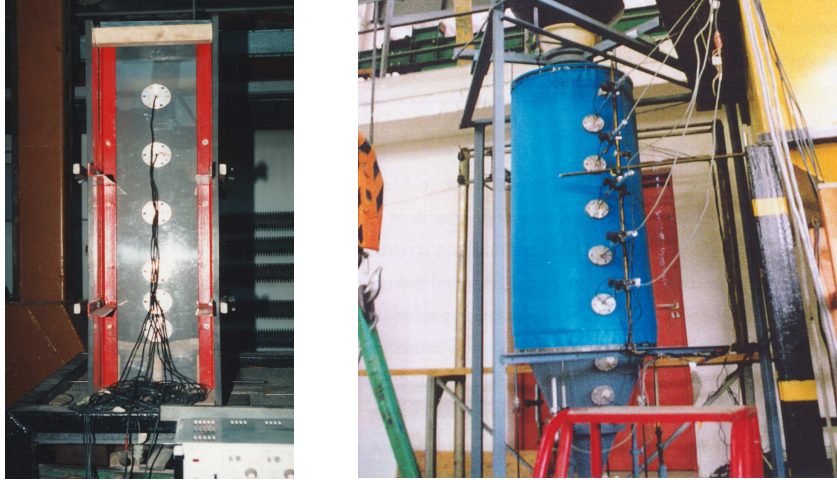

Fig. 16 Measurement pressure of bulk materials on silo models

Results of calculation of this coefficient for rape silo are presented on Fig. 18.

Another coefficient of construction safety [13,14,15] is described by  $\beta$ , the reliability indices interval:  $\beta = z_m / \sigma_z$ , and reliability index of risk failure  $p_f = \Phi(-\beta)$ , where  $z_m$  is the mean value of function  $Z$ ,  $\sigma_z$  is standard deviation of  $Z$ ,  $\Phi(-\beta)$  is Laplace function  $Z = R_G - S_G$  for  $z_m \geq \beta * \sigma_z$  construction work in safe area. Coefficient  $\beta$  is equal according to European standards  $3,7 \div 6,7$ ,  $p_f = 10^{-3} \div 3 \cdot 10^{-8}$ . Coefficient  $\beta$  can be separated to two  $\beta_R$  and  $\beta_S$  connected with strength and loads. According to [17] there are three classes of safety coefficients RC1, RC2, RC3 but in [15,16] we can use either RC0 class. In the last proposal, in case typical for silo loads, where live loads are greater than dead, and when  $R \leq R_d$ ;  $S \geq S_d = \max$ ,  $R$  and  $S$  are independent (index  $d$  is design level).  $\beta = 3,7$  ( $p_f = 10^{-4}$ ),  $\beta_S = 2,59$  ( $p_f = 0,005$ ),  $\beta_R = 2,96$  ( $p_f = 0,0015$ ). Some results were received from investigation on full scale silo, as rape silo [7-12]. According to [13,14,18] loads coefficients  $\gamma_f$  is equal between 1,1 (for temperature)  $1,2 \div 1,5$  (for pressure) but under control of material properties range of  $\gamma_f$  is  $1,2 \div 1,35$ . Coefficient of loads coincidence is 0,9. According to [16]  $\gamma_f$  can be lower than 1,2 for RCO class. In the case of silo loads, when loads of pressure are bigger than temperature loads and big variation of dead loads  $\gamma_f$  can be equal 1,3 for RCO class. According to [11] coefficient of loads coincidence can change from 0,8 to 0,9 for silos under acting high temperatures.

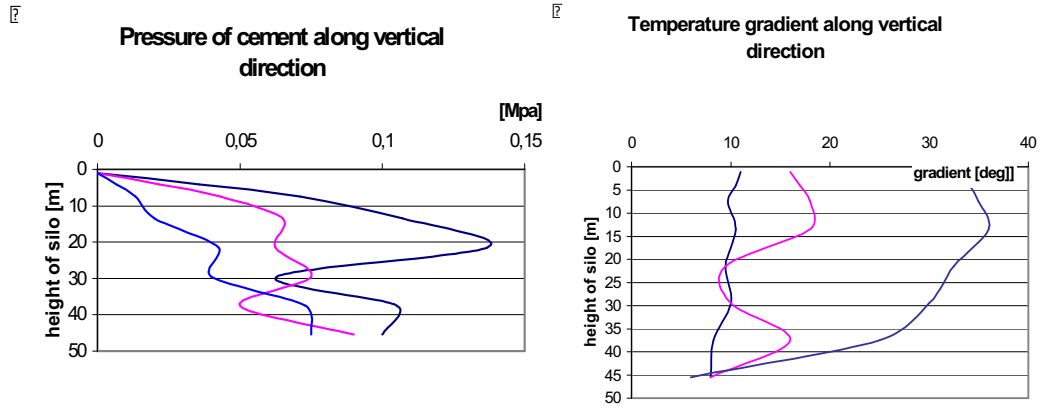

Fig. 17 Results of pressure and temperature gradient measured on full scale silo [3]

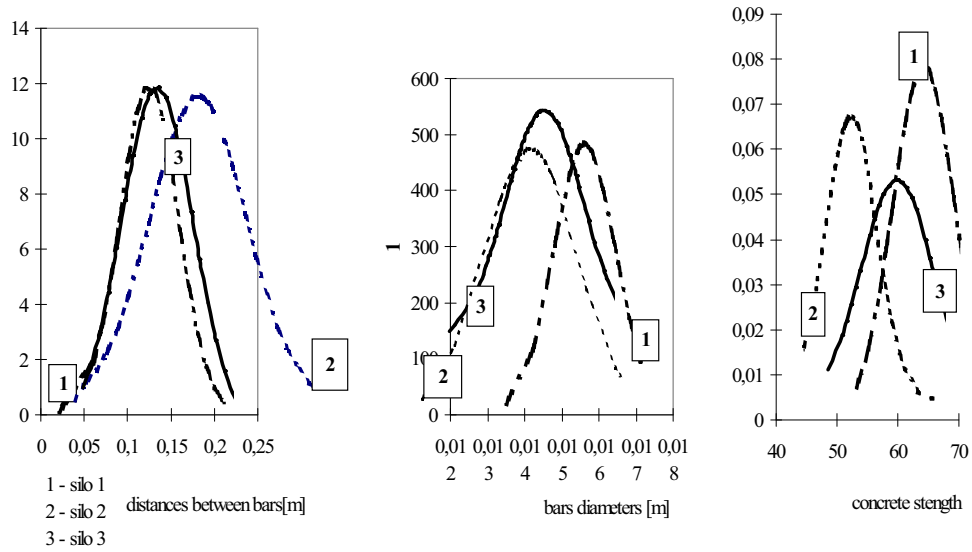

Fig. 18 Some results of measurements of parameters of strength of silo wall

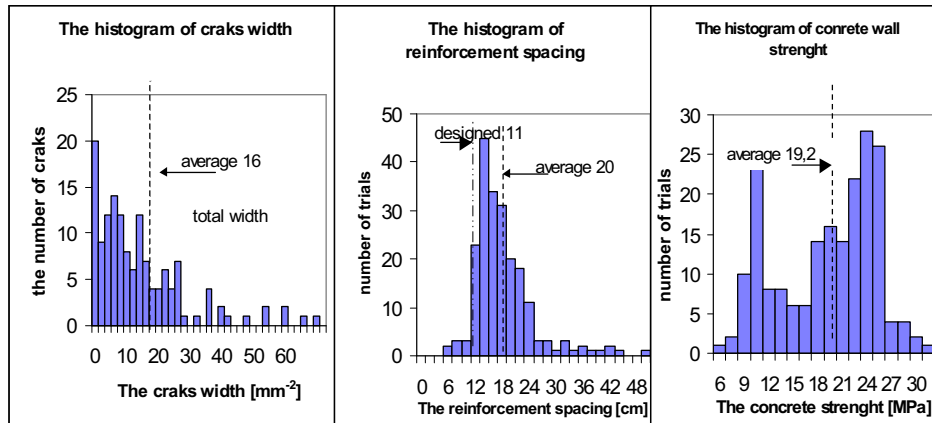

Fig. 19 Some results of measurements of parameters of strength of silo wall

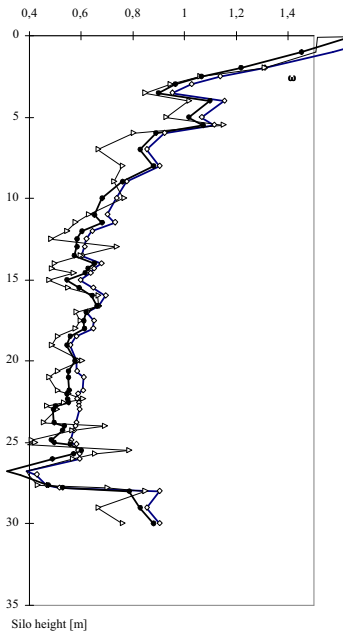

Fig. 20 Distribution of safety index  $\omega$  according to height of silo [11]

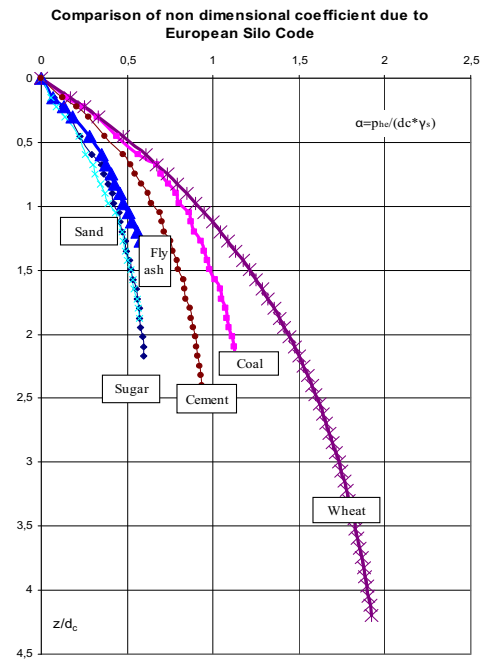

Fig. 21 Comparison of pressure due to European Code

## References

- [1] PN-B-03262/2002, Silo Polish Standard, Silosy żelbetowe na materiały sypkie. Obliczenia statyczne i projektowanie, wykonawstwo.
- [2] A. Borcz, M. Maj, A. Trochanowski, Guiding principles of silo designing, construction and operating, Prace Naukowe Instytutu Budownictwa Polit. Wrocławskiej, Wrocław 1991,
- [3] M. Maj, Wyznaczanie doświadczalne wielkości naporu materiałów sypkich i pola temperatury na wybranych silosach, Politechnika Wrocławska, Wrocław 1995,
- [4] X Intern. Conf. "Reinforced and post tensioned concrete silos." ,Kraków, 1995 Poland
- [5] A. Borcz And H. A. El Rahim, Poland A New Method To Measure Pressure And Temperature In Silos, Bulk Solids & Processing Volume 1, Number 4, November 1989
- [6] M.Kaminski, M. Maj, Reliability Analysis Of The Global Safety Index Design For Concrete Silo., The Third Israeli Conference For Conveying And Handling Of Particulate Solids, Dead Sea, Israel, May 2000
- [7] M. Kamiński, Badania Naporu Bezkohezyjnych Mat. Sypkich W Silosach, Wrocław 86
- [8] Kamiński M., Mrozowicz J., Maj M., Podolski B., Gawron K.: Zagrożenia bezpieczeństwa podczas eksploatacji baterii zblokowanych, prefabrykowanych silosów na rzepak. XX Konferencja Naukowo-Techniczna „Awary budowlane”. Szczecin-Międzyzdroje 2001, s. 183 – 190.
- [9] Instrukcja nr 366/2000 Instytutu Techniki Budowlanej „Zasady oceny bezpieczeństwa i wzmania silosów żelbetowych”. Warszawa 2000.
- [10] Dyduch K., Kamiński M., Mrozowicz J.: Wzmocnienie silosów żelbetowych poprzez sprzężenie cięgnami zewnętrznymi, niskotarciowymi. XVIII Konferencja Naukowo-Techniczna „Awary budowlane”. Szczecin-Międzyzdroje 1997, s. 217-244.
- [11] M.Kaminski, M. Maj, Reliability analysis of the global safety index design for concrete silo., The Third Israeli Conference for Conveying and Handling of Particulate Solids, Dead Sea, Israel, May 2000
- [12] Kamiński M., Mrozowicz J., Maj M., Podolski B., Wróblewski R., Gawron K.: Stan awaryjny baterii zblokowanych silosów na nasiona oleiste. XIX Konferencja Naukowo-Techniczna „Awary budowlane”. Szczecin-Międzyzdroje 1999, s. 821 – 828.
- [13]. Murzewski J., Niezawodność konstrukcji inżynierskich, Arkady, Wwa 1989
- [14]. Pawlikowski J., Zróżnicowanie klas niezawodności konstrukcji z betonu, Prace naukowe ITB Wwa 2003
- [15] Tichy M., Applied Methods of Structural Reliability, Kluwer Academic Publisher, '93
- [16] Pawlikowski J., Jaskulski R., Wiliński P., Oszacowanie Akceptowalnej Miary Zapasu Bezpieczeństwa istniejących Konstrukcji z Betonu, Konferencje ITB Wwa Cedyna, 2004
- [17] Basis of Design of Structures. Proposals for Modification of Partial Safety Factors in Eurocodes, NKB Committee Work Reports, 1999:01 E
- [18] Maj M.The Statistical Estimation Of Loads Coincidence Factor For Silo For Hot Materials, Conference for Conveying and Handling of Particulate Solids, Budapeszt 2003
- [19] M.Kaminski, M. Maj, Experimental and design loads of pressure of bulk materials against silo wall, International Conference on Storing, Handling and transporting Bulk, Barcelona October 2006