

# DEVELOPMENT OF A CARBON FIBRE FRAME FOR REGIONAL MOTORCYCLING CHAMPIONSHIPS

Samuel SANCHEZ-CABALLERO<sup>1</sup>, Bernado A. OLIVER-BORRACHERO<sup>2</sup>, Miguel Angel SELLES<sup>3</sup>,  
Octavio FENOLLAR<sup>4</sup>

<sup>1</sup>Universitat Politècnica de València, sasanca@dimm.upv.es

<sup>2</sup>Universitat Politècnica de València, berolbor@epsa.upv.es

<sup>4</sup>Universitat Politècnica de València, maselles@dimm.upv.es

<sup>3</sup>Universitat Politècnica de València, ocfegi@epsa.upv.es

**Abstract**— Carbon fiber is most often used in high-level competition vehicles for its physical and mechanical properties. The goal of this work is to design and manufacture a motorcycle frame for regional championships, spreading the use of composites technology to teams with fewer resources. The design of the motorcycle used available parts to get the required geometrical features, while keeping in mind that the frame can only be manufactured in a single section, without adhesive bonds to be applied later. The calculations have been carried out using Ansys Workbench software, through the ACP (Ansys Composite Prepost) module of composite materials. The final result is a frame that is 30% lighter than the ones used in the same category, creating a more agile handling and a greater power-to-weight ratio.

**Keywords**— Ansys ACP, FEM, carbon, frame, prepreg, composite, motorcycle.

## I. INTRODUCTION

COMPOUND materials, particularly carbon fiber, are used more often every day in the competitive sports world, which is due to its high fatigue resistance and low density [1].

Compound materials are defined as a combination of two or more constituents with different properties that combine to the macroscopic level, but are insoluble with each other [2].

One of these compound materials is carbon fiber, which is an epoxy resin matrix reinforced with graphite filaments. This material was developed by and for aeronautic-aerospace industry at the beginning of the 1980s for the need of lighter and more resistant materials. Initially, its use was limited to parts without structural responsibility in aircraft and now it is an essential part of this sector [1].

Over time carbon fiber continued its development, and during the 1990s the application of this material expanded to sport and competition vehicles. During the 2000s, there was an exponential increase in its use, to such extent that today it is possible to find carbon fiber

products in practically all fields, both in functional and aesthetic elements.

In the world of motorcycle racing, this material has been integrated for years in the manufacturing of auxiliary complements without large structural requirements, which makes it possible to save some weight. However during the last five years it has been used in the manufacturing of structural parts, which include the tilting or sub-frame. Soon there will be a complete model with full carbon frame, opening the doors of new research and developments.

The chassis of the motorcycle is a structure that holds and gives shape to the vehicle [3]. It is considered the most significant component of a motorcycle, providing rigidity and stability in different conditions. It provides the dimensions and characteristic parameters of each type of motorcycle, which directly affect the handling and stability of vehicle [4].

The technical advantages of this material, along with the possibility of future field study in which comparisons of various models and types of frames from different manufacturers can be made, and to drive a self-manufactured motorcycle, are all the motivations behind this project.

The purpose of this project is to make a one-piece frame with carbon/epoxy Prepreg in a single section, without parts joined by adhesive, for a motorcycle aimed to race in regional or national championships in the 80cc category.

## II. MANUFACTURING PROCESS

### A. Initial considerations

First of all, the final desired geometry for the motorcycle was defined, including factors like distance between axes, forward and launch angle, among others. This section is very important because the handling and the performance of the motorcycle depend on it [4].

The next step is to identify applicable materials to use.

Using CES software based on Professor M. F. Ashby's method, it is possible to display all information about all existing materials in one table, since it uses logarithmic graphs [5]. The most appropriate material was selected according to a performance index calculated from an objective function (minimizing the mass) and a restriction (maximizing the stiffness).

Objective function:

$$m = \rho \cdot L \cdot A \quad (1)$$

Constraints:

$$F_{\text{critical}} = M_{\text{bending}} / z \leq \sigma_f / s_f \quad (2)$$

The above equation minimizes the mass then maximizes the inverse of the function  $\rho / E^{1/3}$ .

The performance index is the key to selecting the material because it uses the system loads (bending, torsion, compression, traction) and the piece's shape [5].

### B. Chassis design.

The first step is to create a sketch of the desired geometries for the motorcycle and then to position the available auxiliary components, which have been drawn previously (Fig. 1).

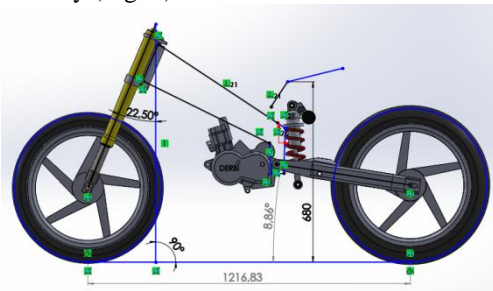

Fig. 1. The positioning of the components on the geometries sketch.

Once the components were drawn and positioned in the assembly, modifications were made to the appropriate parts in CAD (Computer Aided Design), and then in the whole part, to get the desired geometries. An example of one of these modifications was that the rear tilting that had to be shortened (Fig. 3).

Next step was the frame design process, where different models were generated until the most appropriate frame for the specific type of motorcycle was found. This optimum frame was the main frame in carbon fibre with machined aluminium lateral supports (Fig. 2).



Fig. 2. The final design of the frame in carbon and aluminium.

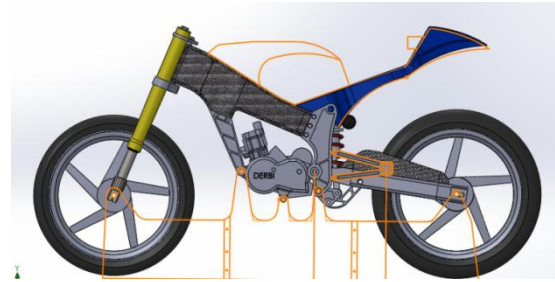

Fig. 3. Motorcycle design with the main components.

It is important keep in mind that the available tools limited the design and the subsequent manufacturing process of the moulds. It was because of this that a design with angles that facilitated an easy exit from the mould (Fig. 4) was chosen instead of a design with negative angles regarding CNC (Computer Numeric Control) head perpendicular axis.

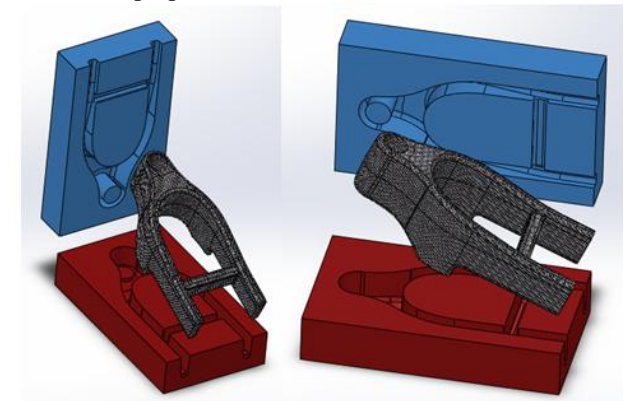

Fig. 4. Mould design.

### C. Definition of the load hypothesis.

To carry out the finite element analysis method, it is needed to define a loaded hypothesis, which in this case will be maximum braking, corner speed, and impact with an object on the road [7].

As there are a large number of unknown variables, and data telemetry equipment was not available for the data gathering. These values are obtained from the doctoral thesis in [6] developed in the Mechanical Engineering Department of the University of Rome regarding an Aprilia RSV 1000 motorcycle. This motorbike weights approximately three times more than the motorcycle of this project, so the calculations for the frame will be oversized.

The first hypothesis, maximum braking, is also the most important one when dealing with frames because it occurs most often while in competition. It is assumed that only the front break equipment is used to produce a moment in the steering pipe will be as large as possible. This is because, if the rear brake is also used, its moment will counter-act the applied moment in steering pipe.

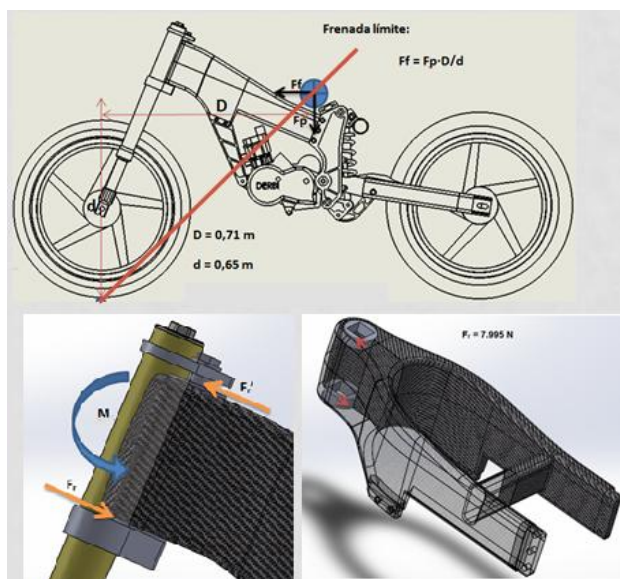

Fig. 5. The result of forces in breaking hypothesis.

The result of the forces from this hypothesis was a torque applied on the fork, which generates two equal forces with reverse direction applied at the ends of the steering pipe (Fig. 5).

The second hypothesis consists of a corner speed of 100 km/h with turning radius of 60 m. It should be kept in mind that neither acceleration nor breaking forces will exist in the turn because the speed is assumed to be constant, and the slipping between tires and pavement is assumed that does not exist. The result for this hypothesis was two equal forces with reverse direction applied at the steering pipe as a result of the generated torque (Fig. 6).

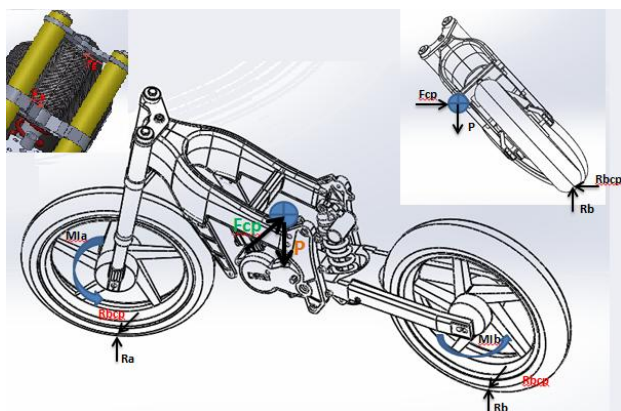

Fig. 6. The result of forces in the cornering hypothesis.

The last hypothesis considers the situation when the motorcycle passes over a 100 mm high obstacle at a speed of 50 km/h. The force value is highest on the frame in this is the case, although for this kind of motorcycle it is difficult to assume a track exit. The result of this hypothesis was a force at the bottom of the pipe, which has the direction of the axis of steering pipe, in the ascending sense (Fig. 7).

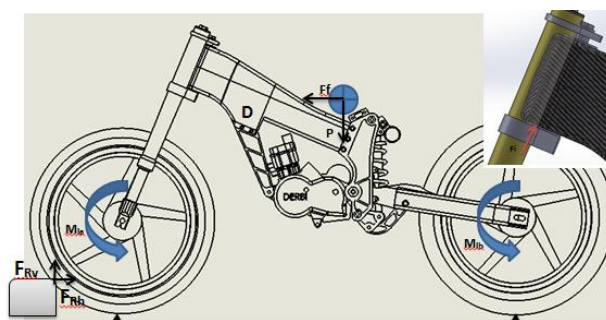

Fig. 7. The result of forces in obstacle hypothesis.

#### D.FEM (Finite Element Model) analysis.

Because the frame it is a composite material structure, it was necessary to do an analysis with a program specially designed for this material.

The ACP module of Ansys workbench was used for composite material calculations and shows many advantages including the possibility to create fabrics, modify the fibres orientation, add or remove layers depending on the needs, etc.

In general terms, the procedure for the finite element calculation has followed the following steps for each of the three calculation hypothesis:

- 1) *Converting Solidworks geometry to parasolid format or another accepted one by Ansys*
- 2) *Create a new study and import the file from Ansys workbench*
- 3) *Modify the geometry using the Ansys Design Modeller editor to convert the solid to sheet (surface)*

Once the geometry was defined, the “setup” analysis was started as if it was a piece of isotropic material [8].

The contact between the aluminium parts with carbon was considered to be welded contacts (Fig. 8).

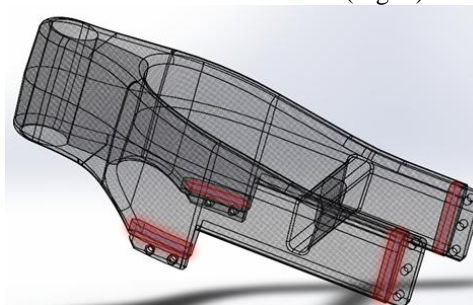

Fig. 8. Fastening detail. Bonded contact.

In order to apply the load, it was necessary to design non-deformable cylinders to simulate the bearings, making easier the task of load apply, distributing the stress in a more realistic way.



From this study we got the maximum stress and the outer sheet geometry (surface) as a link with the ACP. This linked the different modules that we used.

Once the first solution with Ansys workbench was obtained, the work with the composite material module ACP started. Next, the information regarding the material to be used was imported to the pre-processor Ansys ACP (composite module). It was a cf 0700 carbon fibre and VTM264 epoxy resin with a medium viscosity with more than 21 degrees and low with less than 15 degrees.

Right after that, we defined the type of fabric, which was Twill 2x2 660gms, the number of layers, and laminate orientation (90, 45, -45, 0).

Finally, this study it was imported into the post-processor of Ansys ACP (composite module) to define the calculation rules and to get the results.

From the obtained results, it should be pointed out that the first hypothesis, maximum breaking, is the most repetitive and showed the most critical values with a maximum deformation 0.499 mm (Fig. 9), a maximum stress 62 MPa (Fig. 10) and a safety coefficient of 4.2 (Fig. 11).

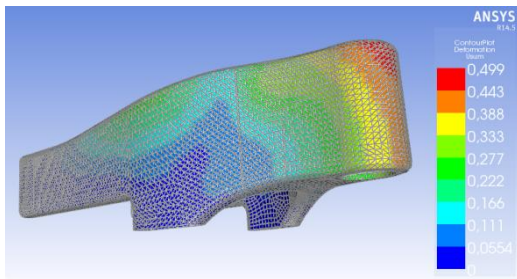

Fig. 9. FEM analysis. Deformation level (mm).

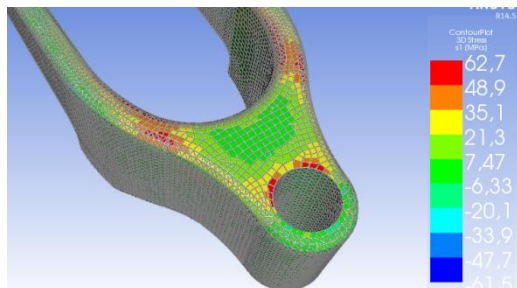
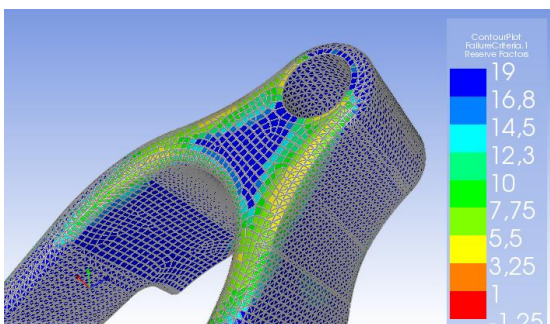

Fig. 10. FEM analysis. Stress level (MPa).



11. FEM analysis. Safety coefficient (Ne=4.2).

#### E. Manufacturing process.

The first step was to manufacture the moulds. Two blooms in a CNC router were created, using a 12 mm cylindrical milling cutter with the rough edge down. The finishing touch was created with a milling cutter of 4 mm radius ball (Fig. 12).



Fig. 12. Mould machine. Rough down operation.

Once the CNC machined process ended the finishing works and mould preparation was made that, which is describe next [9], [10], [11]:

- 1) *Abrasive sanding to homogenize areas.*
- 2) *Affine sanding.*
- 3) *Painted with several layers of sealer.*
- 4) *Surface sanding.*
- 5) *Varnish application.*
- 6) *Sanding with low weight sheet.*
- 7) *Polished with car polish.*
- 8) *Pore sealer treatment.*
- 9) *Treatment with mould releases agent.*

As mentioned above, the frame was made in carbon fibre prepreg VTF261/CF3200-40%RW for fair face (one layer) and to provide the necessary resistance VTF264/CF0700-40%RW (four layers).

Prepeg is a pre-impregnated carbon and epoxy resin that has been stopped in the cured cycle and is in the b-stage state [12].

After applying the mould release agent overall mould surfaces, the fiber cutting patterns using masking tape pasted on the frame geometry was made. Then the shapes were scratched and pasted on cardboard to obtain a dimensionally stable pattern [12].

Once the patterns were obtained, they were digitalized to cut the prepreg with that shape, but in an appropriate angle position (90, 45, -45, 0 degrees).

Next the lamination of first layer that was the fair face was made. In this first laminate all cuts followed the same orientation to have a uniform finish.



Fig. 13. First layer lamination and compaction in a vacuum bag.

To improve the adhesion balancing at all points of the mould, the material was compressed using vacuum bags after the application of each material layer.

Then two layers were laminated of VTF264/CF0700-40%RW in the described angles (Fig. 13-14).

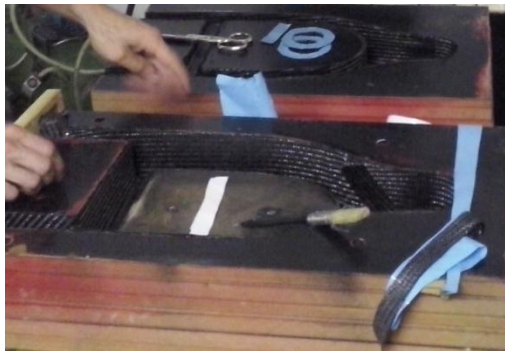

Fig. 14. Layers VTF264/CF0700-40%RW laminate.

Next, since the frame should be in one piece, the aluminium pieces that were involved were put inside. It should be pointed out that it is convenient to isolate aluminium pieces of the carbon fibre with a thin layer of laminate fiberglass to avoid potential problems in the join by corrosion generated by the potential difference.

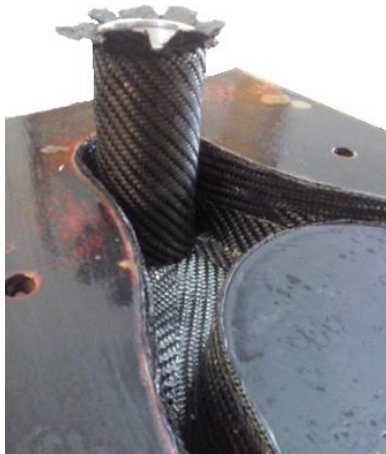

Fig. 15. Positioning and laminating of aluminium parts.

Once laminating the aluminium pieces was positioned at  $-45$  and  $0$  degrees of VTF264/CF0700-40%RW. To make the laminates, the two frame halves were joined after leaving an outgoing fiber flap around the perimeter of the bottom mould geometry (Fig. 15-16).

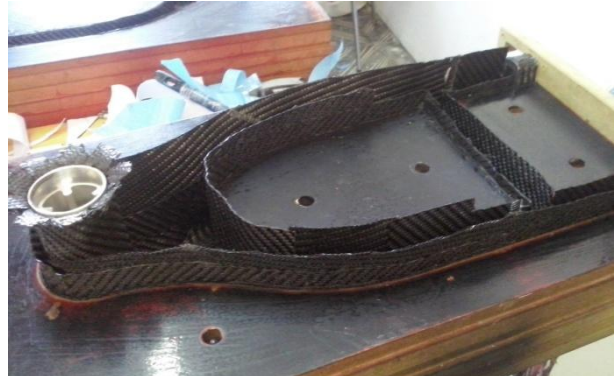

Fig. 16. Last layer laminate. Detail of join flaps.

For this kind of mould and joining a system of the parts, it was not necessary to cure these in an autoclave because the pressure produced was positive and may be of a magnitude similar to the autoclave (2-6 bar).

To produce the pressure, we used a vacuum bag with a shut-off valve tire of the bike, which provided its inflation. Some kind of preformed inflatable latex bladder could also have been used (Fig. 17).



Fig. 17. Vacuum bag positioning. Lateral join flaps detail and joins flaps in the shank.

Then steering upper reinforcements were installed and bent on the vacuum bag around the perimeter. Excess laminates joined the two halves of the piece in order to lift them, generating contact between two parts of the piece when the pressure was provided to the bag.

Next the mould carefully closed, using the lateral centring and steering pipe centring. Once the mould was perfectly closed and centred the pressure was applied and the mould cured, and in this case for 5 hours at  $80$  degrees, using heating ramps (2 degrees per minute) and cooling (3 degrees per minute), thus obtaining a  $95$  degrees  $T_g$ , sufficient for the frame application. After cured time the frame was removed from the mould (Fig. 18-19).



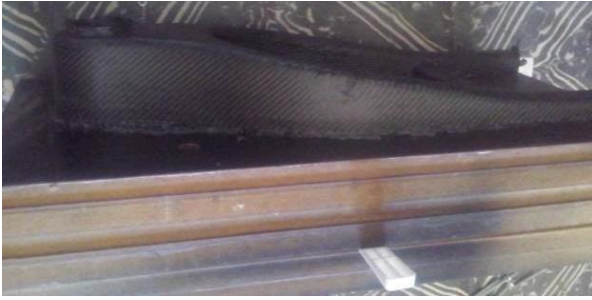

Fig. 18. Frame unmould.

Finally a varnish coat was applied with UV protection to prevent it degrade from sunlight exposure.



Fig. 19. Principal frame finished with UV protection.

### III. CONCLUSION

The final result is a frame 30% lighter than the average ones used in the same category, which together with its new geometry will imply a more agile handling and a greater power-to-weight ratio.

In this way the settled expectations stated at the beginning of the project, which was weight reduction and manufacturing in single section process, were achieved successfully in the absence of the comparisons with racing results.

### REFERENCES

- [1] L. Venegas, A. Monsalve, B. Díaz. "Propuesta de una reparación sobre placas de fibra de carbon sometidas a impacto balístico". *Anales de la Mecánica de Fractura*, volume 2, 2007..
- [2] J.G. delaFigal, P.A. Rodríguez, "El cálculo de los materiales compuestos por elementos finitos"..
- [3] P.M Arias. "Motocicletas". Madrid, España: Dossat, 1999.
- [4] Foale, Tony. "Motocicletas: Comportamiento Dinámico Y Diseño De Chasis". El Arte Y La Ciencia. S.l.: Tony Foale Designs, 2003.
- [5] A. Nadal. "Apuntes de ingeniería de materiales". 2008
- [6] G. Guerra, G. Polucci.. "Dimensionamento di un telaio di motocicletta: modello di simulazione e risultati di calcolo." *Mototecnica*, 8, 2003.
- [7] P. Vergara. "Modelado analisis y simulación de un chasis de motocicleta". Master's thesis, Universidad Carlos III, 2011
- [8] A. Liberatto. "Ansys composite prepost". Technical report, 2010.
- [9] J. Wanberg, "Composite Materials: Fabrication Handbook 1". Number v. 1 in Composite Materials. Wolfgang Publications, 2009.
- [10] J. Wanberg. "Composite Materials: Handbook 3". Wolfgang Publications, 2010.
- [11] D. Hull, "Materiales Compuestos". Barcelona: Reverté, 1987.
- [12] A. Miravete, E. Larrodé. "Materiales Compuestos". Zaragoza: Antonio Miravete, 2000.