



UNIVERSITAT  
POLITÈCNICA  
DE VALÈNCIA

# CALCULO DE LOS COSTES DE ENERGIA Y SU GESTION PARA MINIMIZAR COSTES

Boyko's Metal Finishing CO

*MARIA JOSE DEMA FRESNEDA  
GIULIANO BERENATO  
TIMOTHY ELLIS  
CARLOS MIGUEL MORENO MARIN*



NJIT

New Jersey's Science &  
Technology University

# ENERGY COST AND CONTROL MANAGEMENT

Boyko's Metal Finishing CO

*MARIA JOSE DEMA FRESNEDA  
GIULIANO BERENATO  
TIMOTHY ELLIS  
CARLOS MIGUEL MORENO MARIN*



## **Acknowledgment**

The project opportunity we had with Boyko's Metal Finishing Company was a great chance for learning and professional development. Therefore, we consider ourselves as very lucky people as we were provided with an opportunity to be a part of it. We are also grateful for having had a chance to meet so many wonderful people and professionals.

In performing our project, we had to take the help and guideline of some respected persons, who deserve our greatest gratitude. The completion of this assignment gives us much Pleasure. We would like to show our gratitude Mr. Abdel-Malek, professor of New Jersey Institute of Technology for giving us a good guideline for assignment throughout numerous consultations. We would also like to expand our deepest gratitude to all those who have directly and indirectly guided us in writing this assignment.

We are also grateful to New Jersey Institute of Technology for provision of expertise, and technical support during this project. Without their superior knowledge and experience, the Project would like in quality of outcomes, and thus their support has been essential.

Nevertheless, we express our gratitude toward our families and colleagues for their kind co-operation and encouragement which help us in completion of this project.

## Table of contents

1.	Introduction and executive summary.....	6
2.	Study of the actual energy consumption .....	7
3.	Energy savings by the addition of AC Drives.....	10
3.1.	Definition of the Study.....	10
3.2.	Benefits of an AC Drive .....	11
3.3.	Pumps in Powder Coating Process .....	16
3.4.	Characteristics of Penguin P-Series Pumps. ....	18
3.5.	Characteristics of UNI-SPRAY SYSTEMS nozzles .....	19
3.6.	Working conditions of pumps and nozzles, Power consumed .....	20
3.7.	Pumps regulation with an AC drive .....	25
3.8.	Fan in Dust Collector in Powder Coating Process.....	30
3.9.	AC Drive chosen.....	32
3.10.	Installation of the AC Drive.....	35
3.11.	Maintenance intervals .....	48
3.12.	Return on Investment on adding AC Drives to the actual process.....	51
3.13.	Recommendations.....	61
4.	Lightning System .....	62
4.1.	Summary.....	62
4.2.	Introduction .....	64
4.3.	OSHA Regulations .....	66
4.4.	Fundamentals of Lighting and Illumination:.....	72
4.5.	Light sources .....	84

4.6.	Solutions Implementation .....	89
4.7.	Investment Analysis.....	94
4.8.	Recommendations.....	99
5.	Meters.....	100
5.1.	Scope .....	100
5.2.	Current Conditions .....	100
5.3.	Proposed solution.....	101
6.	PSE&G Billing Period .....	104
6.1.	Overview.....	104
6.2.	Scope .....	104
6.3.	Current situation.....	105
6.4.	Proposed solution.....	105
6.5.	Recommendations.....	106
7.	References Cited .....	107
8.	Appendix .....	108
8.1.	Appendix 1. Comparison Chart.....	108
8.2.	Appendix 2: LHB5-4-24000-40K-U80-UNI.IES.....	110
8.3.	Appendix 3: LW4 SERIES Architectural Linear Ambient LED Luminaire .....	113

## **1. Introduction and executive summary.**

Boyko's Metal Finishing CO. is a facility located in Newark, New Jersey, that encompasses 2,500 sqft. This organization primarily operates in the powder coating industry within the Fabricated Metal Products sector, providing powder coating, metal finishing, enameling, metal spraying, and hot dipping services. This organization has been operating for approximately 56 years. The company hires 20 – 49 employees and has an annual revenue of \$2.5 to \$5 million. The company was once located across the street at 85-87 Poinier St, Newark. They moved to their current location, 100 Poinier St, Newark, to expand and better their business.

This project has the aim of helping Boyko's Metal Finishing CO. to reduce the amount of energy consumed, becoming more environmentally friendly. This is one of the main concerns of the owner, Mr. John Boyko. Basically, in our project we have developed different alternatives for reducing the quantity of electricity consumed.

First of all, we did an analysis of the bills for understanding the amount of energy used by the company and then discussed different options for reducing it.

In the first part of the project, there is a study of the benefits of adding AC drives to the actual process, putting them in the pumps and in the fan in the dust collector that the company has.

Then, on the second part we developed another study for replacing the actual lightning system. Changing and using LED bulbs will reduce the amount of energy and also will produce cold light, that it's better.

Later on, we looked for testing and replacement of the gas and electricity meters, changing the company's billing period and search alternative suppliers for gas and electricity. This was required by the owner Mr. John Boyko.

The main contribution that we expect from this project is that Boyko's Metal Finishing will save money from applying our recommendations and also that it will become more environmentally friendly by reducing the amount of energy consumed.

## 2. Study of the actual energy consumption

The first step in our project is to understand the actual energy consumption. The factory supplier for gas and electricity is PSE&G, so what we are going to do is to study PSE&G bills for understanding the actual electric and gas consumption.

Boyko Finishing Metals & Co. works using a GLP program that means General Lighting and Power Service.

The main charges are the following:

- *Delivery Charges:* Charges for delivering electricity through wires from supply sources to homes and businesses. These charges include a service charge, kilowatt-hour usage charges and demand charges. The Societal Benefits Charge, Non-utility Generation Charge, Securitization Transition Charges, System Control Charge, Solar Pilot Recovery Charge, Green Programs Recovery Charge and, where applicable, Commercial and Industrial Energy Pricing (CIEP) Standby Fee are applied to kilowatt-hour use. PSE&G realizes no profit from the charges below. They allow PSE&G to recover the actual associated program costs to service our customers
- *Social Benefits Charge:* A charge to recover the cost of government-mandated programs designed to achieve public policy goals, such as energy conservation.
- *Securitization Transition Charges:* The Transition Bond Charge and the MTC-Tax Charge recovers costs and associated taxes for transition bonds collected by PSE&G as servicer on behalf of PSE&G Transition Funding LLC.
- *Supply Charge:* The generation charge, including the cost of the transmission from generation facilities to the local distribution system.
- *Third Party Supply:* A customer may choose to receive electric supply from PSE&G or a third party supplier. A customer who receives electric supply from a third party supplier will not have to pay the Capacity Charges, Transmission Charges, or the Basic Generation Service Charges (BGS) to PSE&G. The price to compare, for PSE&G's Capacity, Transmission and Basic Generation Service Energy for customers, by rate schedule, are as indicated in the table on the following page.



In this case the company use a BGS plan to PSE&G. However, the appendix at the end of this chapter shows all the prices for kWh for each charges.

After analyzing the bills, we observed:

Figure 1 Total kWh energy consumed

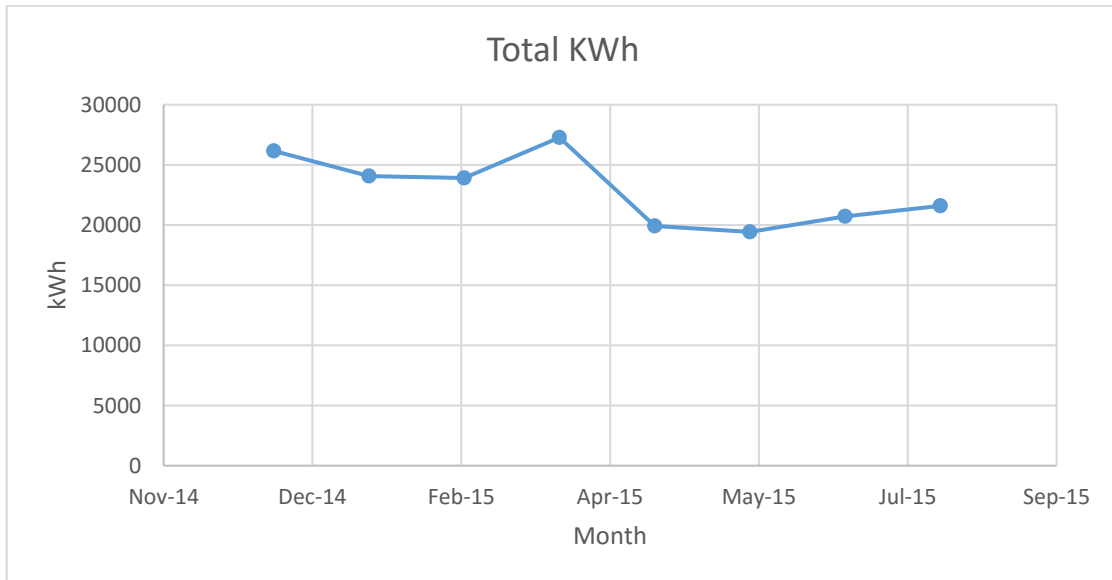
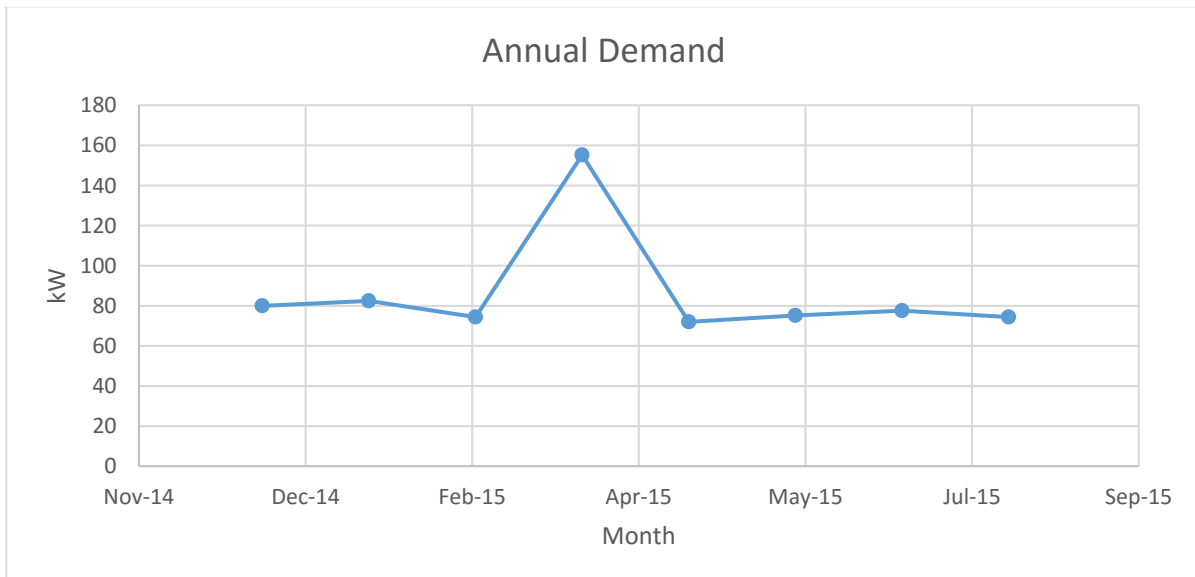

Figure 2 Annual Demand



After analyzing the Total kWh consumed and the Annual demand, we decided to develop solutions for reducing the amount of electricity consumed. Those solutions are developed in the next chapters.

About gas, we didn't have many ways to reduce the amount of energy consumed since we cannot close the oven because of the conveyor. We will look for different suppliers in order to reduce the bills.

### **3. Energy savings by the addition of AC Drives.**

#### **3.1. Definition of the Study**

The purpose of this chapter to evaluate the energy and demand savings by adding AC drives to two 3 HP 460v pump motor, and a 5 HP 460v pump motor. Also we are going to add and AC drive to a 10 HP 460v motor for the fan located at the dust collector.

Since the pumps and fan are working at full power, the addition of an AC drive would regulate and then reduce the amount of energy consumed.

The pumps of this study are located in the washer of the powder coating process, which is the first step of the process. The two 3 HP and the 5 HP pumps pertain to the Penguin P-Series. The motor of the fan is located at the dust collector, which absorbs the residual powder from the powder coating station. It is a 10 HP motor, with an assumed efficiency of 85%. Both pumps and fan will be defined in the next sections.

## 3.2. Benefits of an AC Drive

An AC drive is a device used to control the speed of an electrical motor in an energy-efficient way. In hybrid technologies, AC drives are used to combine conventional energy sources and energy storages to create total energy management solutions.

The need for energy conservation in order to save the environment is a key driver in the development of speed control devices, and AC drives provide the optimum method of controlling the speed of electrical motors to match load demand. Even small changes in motor speed can cause significant changes in energy consumption.

AC drives adjust the motor speed and torque by varying motor input frequency and voltage.

As AC drives provide the following basic advantages:

- Energy savings, when using speed to reduce capacity, both the head and flow are reduced, maximizing the energy savings.
- Reduction of thermal and mechanical stresses on motors and belts during starts
- Lower KVA, helping alleviate voltage sags and power outages.

*Image 1 AC Drives of ABB*



ABB AC Drives have a type designation, which is shown in the following figure. As we see, each number contains very important information. If any system has special requirements, it is possible to build up your own ordering code using the type designation key below or contact your local ABB drives sales office and let them know what you want.

*Image 2 Type Designation of AC Drives*

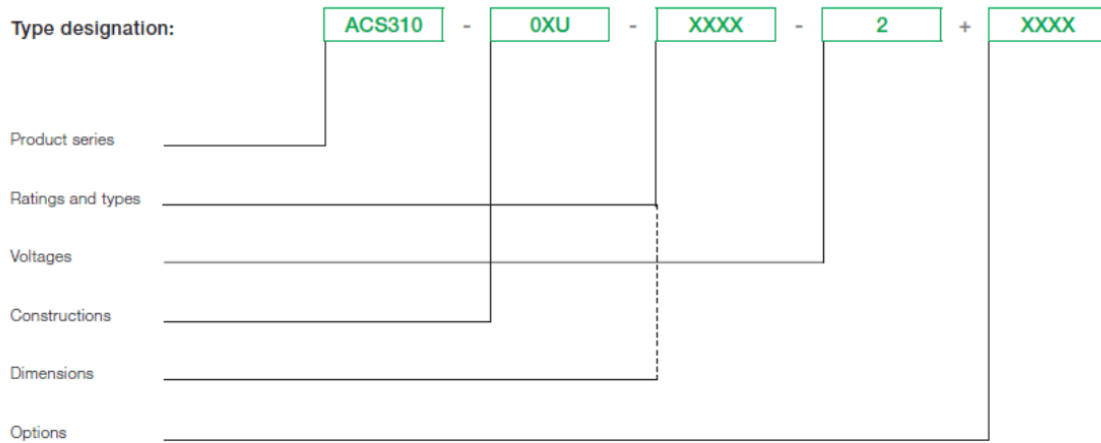

The type designation is the unique reference number that clearly identifies the drive by power rating and frame size. Once the drive's type designation has been selected, the frame size can be used to determine the drive dimensions.

The construction depends on the drive phase and EMC filtering. 01 means 1-phase and 03 means 3-phase.

Insert either "2" or "4", depending on your chosen voltage:

2 = 200 to 240 V

4 = 380 to 480 V

For dimensions depends if it is Cabinet-mounted drives (IP20 UL open) or Wall-mounted drives (NEMA 1)

Image 3 Dimensions of cabinet-mounted drives

Cabinet-mounted drives (IP20 UL open)

Frame size	IP20 UL open					
	H1 in	H2 in	H3 in	W in	D in	Weight lb
R0	6.65	7.95	9.41	2.76	6.34	2.4
R1	6.65	7.95	9.41	2.76	6.34	2.9
R2	6.65	7.95	9.41	4.13	6.5	3.3
R3	6.65	7.95	9.29	6.65	6.65	6.4
R4	7.13	7.95	9.61	10.24	6.65	9.7

H1 = Height without fastenings and clamping plate  
 H2 = Height with fastenings but without clamping plate  
 H3 = Height with fastenings and clamping plate  
 W = Width  
 D = Depth

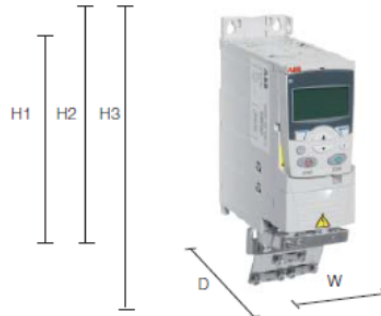
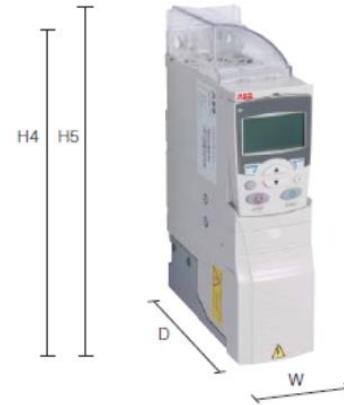

Image 4 Dimension of wall-mounted drives

Wall-mounted drives (NEMA 1)

Frame size	NEMA 1				
	H4 in	H5 in	W in	D in	Weight lb
R0	10.12	11.02	2.76	6.65	3.3
R1	10.12	11.02	2.76	6.65	3.7
R2	10.12	11.1	4.13	6.65	4.2
R3	10.24	11.77	6.65	6.97	7.7
R4	10.63	12.6	10.24	6.97	11

H4 = Height with fastenings and NEMA 1 connection box  
 H5 = Height with fastenings, NEMA 1 connection box and hood  
 W = Width  
 D = Depth



As options, there are some shown in the table below.

Table 1 Additional options to the AC Drives

Options	Ordering code	Description	Model
Protection class	1	NEMA 1/UL type 1 (R0, R1, R2)	MUL1-R1
	1	NEMA 1/UL type 1 (R3)	MUL1-R3
	1	NEMA 1/UL type 1 (R4)	MUL1-R4
Control panel	J400	Assistant control panel	ACS-CP-A
	J404	Basic control panel	ACS-CP-C
Panel mounting kit	1	Panel mounting kit	ACS/H-CP-EXT
	1	Panel holder mounting kit	OPMP-01
Extension modules	L511	Relay output extension module. Option includes three (3) additional relay outputs.	MREL-01
Tools	1	FlashDrop tool	MFDT-01
	1	DriveWindow Light	DriveWindow Light
External options	1	Input chokes	
	1	EMC filters	
Remote monitoring	1	Ethernet adapter	SREA-01

For user interface, we think that the best option for Boyko’s Metal Finishing Co. would be the assistant control panel because features a multilingual alphanumeric display for easy drive programming. The control panel has various assistants and a built-in help function to guide the user. It includes a real time clock, which can be used during fault logging and in controlling the drive, such as at start/stop. The control panel can be used for copying parameters for back up or for downloading to another drive. A large graphical display and soft keys make it extremely easy to navigate.

Image 5 Assistant control



With an AC Drive in pumping applications, energy savings up to 50 percent can be achieved compared to direct-on-line motor-driven systems that use mechanical flow control methods. Energy savings can be easily monitored using the built-in counters that display energy savings in kilowatt hours and saved carbon dioxide emissions. The savings can also be displayed in local currencies. In the next table we can find some advantages and benefits.

Table 2 Advantages and benefits of AC Drives features

Feature	Advantage	Benefit
Pump and fan control (PFC) feature to control pumps and fans in parallel	One drive controls several pumps or fans and eliminates the need for an external programmable logic controller. Reduces motor stress and increases lifetime when auxiliary motors are driven according to the needed pump/fan capacity. Interlock function enables one motor to be disengaged from the mains supply while others continue operating in parallel.	Saves cost of additional drives and external PLC. Longer life for pump or fan systems while reducing maintenance time and costs. Maintenance can be carried out safely without stopping the process.
Soft pump and fan control feature (SPFC)	Reduces unwanted pressure peaks in pumps and pipelines when an auxiliary motor is started. Reduces inrush current to the power network while connecting new auxiliary motors.	Reduces maintenance costs. Longer life for pump or fan systems. Smoother processes
Pump protection functions	Integrated protection and control with preprogrammed features like pipe cleaning, pipe fill, inlet/outlet pressure supervision and detection of under or over load for preventive maintenance. Improves process control and system reliability. Integrates system protection. Smoother processes: improved and optimized system. Longer life for pump and fan systems, reduced maintenance costs.	Reduces maintenance costs. Longer life and reliable operation of pump systems.
PID controllers	Varies the drive's performance according to the need of the application.	Enhances production output, stability and accuracy.
Embedded Modbus EIA- 485 fieldbus interface	No need for external fieldbus options. Integrated and compact design.	Saves costs of external fieldbus devices. Increases reliability.
On/off cooling fan control	Cooling fan rotates only when the drive is running, thereby cooling only when needed.	Silent operation. Improves drive's energy efficiency.
Software controlled phase inversion	Fast and easy way to change the phase order of the motor rotation	Time savings as there is no need to change the output cable order manually.
Short parameter menu view	Only the most needed drive parameters are shown on the drive's parameter view. Complete parameter view can be changed by setting one parameter	Time savings as the user quickly sees the most important parameters. Fast commissioning of the drive
Energy optimizer	Improved motor efficiency with intelligent drive control method, especially while operating on partial centrifugal loads	Boosts energy efficiency due to lower motor currents. Reduces audible noise from the motor.
Energy efficiency counters	Several counters to illustrate saved energy (kWh), carbon-dioxide emissions (CO2) and cost in local currency.	Shows direct impact on energy bill and helps control operational expenditure (OPEX).
Full output current at 50 °C ambient	The drive can be operated in ambient temperatures up to 50 °C without derating the output current.	Optimized drive dimensioning for wide temperature ranges.
Load analyzer	Load analyzer saves process data, such as current and torque values, which can be used to analyze the process and dimensioning of the drive and motor.	Optimized dimensioning of the drive, motor and process.
Compact size and flexible mounting options	The high power-to-size ratio of the drive facilitates efficient cabinet space usage. Optimum installation layout. Flexible installation with screw or DIN rail mounting. Drive can be installed sideways or side-by-side.	Space savings.
User interfaces	Assistant control panel with clear alphanumeric dynamic menus, real time clock and 14 languages. Basic panel with numerical display	Different control panels available according to functionality needs.
Maintenance assistant	Monitors consumed energy (kWh), running hours or motor rotation.	Assists in preventive maintenance of the drive, motor or run application.
Commissioning assistants	Easy setup of parameters for PID controllers, real-time clock, serial communication, drive optimizer and drive startup.	Time savings with reduced need to set the parameters manually. Ensures all required parameters are set.
Drive protection	Motor output and I/O protected against wiring faults. Protection against unstable supply networks. Coated boards as standard.	Latest solution to protect the drive and offer trouble free use and the highest quality



### **3.3. Pumps in Powder Coating Process**

The pumps are right now running at full power, connected directly to the electric network. As pumps would give an enormous flow working without restrictions, the system has a regulation valve for each pump, which limits the flow that the pumps send to the nozzles.

As mentioned before, the pumps are located in the washer. The purpose of the washer is to eliminate the dust and particles that metal pieces could have, before doing the powder coating. Pieces are transported from several companies to Boyko's Metal Finishing factory and there is a high probability that this could happen.

About the process, metal pieces are putted in the conveyor and then they are transported into the washer. This process is divided into 3 steps:

#### **Chemical wash**

When the metal pieces enter into the washer, they are cleaned with a chemical wash at high temperature. The 5 HP pump impulses the chemical solution from a tank to the nozzles through the pipes. Those nozzles spread out the chemical solution to the surface of the pieces, cleaning them.

The system has 84 nozzles (UNI-SPRAY SYSTEMS, UNI 5040) distributed on 14 rows of 6 each one.

#### **Water wash**

After the first step, the metal pieces are transported to the second part of the washer, where they are cleaned again. This time pieces are cleaned with water. The purpose is to remove the chemical solution fluids that could still be in the surface of the pieces. As in the first part, we have two pumps impulsing the water to the nozzles. The 3 HP pumps work in this step.

The system has 36 nozzles for each pump (UNI-SPRAY SYSTEMS, UNI 5040) distributed on 6 rows of 6 each one.

## **Drying of pieces**

After the second step, pieces are dried with heat, eliminating the remaining water from the surface. The water and chemical solution steam that could be inside the washer is eliminated by natural convection through an exhaust.

After this, pieces are transported to a visual inspection area, before arriving to the powder coating station.

### **3.4. Characteristics of Penguin P-Series Pumps.**

Here we are going to describe the characteristics based on the description given by the manufacturer.

Penguin vertical immersible pumps are compact, portable, and self-priming when immersed. Simple in design and efficient in performance, this pump has only one moving part.

Penguin vertical immersible pumps are constructed completely of CPVC, polypropylene, or PVDF where in contact with the solution, this pump is suitable for pumping, agitating, filtering, or circulating acid and alkaline solutions (pH 0-14), abrasive fluids, and other corrosive solutions. Maximum temperature ratings are as follows: CPVC-180°F, polypropylene-150°F, and PVDF-260°F. Because PVDF is ultra-pure, it is recommended for use in high purity deionized water, HF, and liquids that must remain contamination free.

The Penguin vertical pump has a rigid, solid stainless steel, one-piece rotor drive shaft covered with a two-piece sleeve and impeller. Titanium shafts are available as an option. Because of the unique double impeller design, this pump has no seals, no pump bearings, no bushings, no wearing parts, and thus requires little maintenance.

### 3.5. Characteristics of UNI-SPRAY SYSTEMS nozzles

Here we are going to describe the characteristics of the nozzles based on the description given by the manufacturer. As we know, the water impulsed by the pumps is distributed by 84 nozzles in the 5 HP pump, and by 36 nozzles in each of the 3 HP pumps.

Uni-Spray Nozzles are injection molded from custom-blended polypropylene, a cost-effective material that is corrosion and heat-resistant and impervious to most chemicals. The tip design resists clogging and buildup due to its smooth shape and low coefficient of friction. A wide variety of Uni-Spray Clamp-On Nozzles are available to suit your application and are color-coded for easy identification. All nozzles are available with a Single-Spring or an optional Double-Spring configuration for pressures over 60 psi (4.0 bar). All nozzles are available in three spigot sizes, to fit 9/16", 21/32" or 13/16" (14 mm, 17 mm and 19 mm) diameter.

The nozzles we are actually using are UNI5040 and have the capacity shown in Table 3:

*Table 3 Capacity of UNI-SPRAY 50 series*

ITEM NO.	NOZZLE TIP PART NUMBER	TIP COLOUR	SPRAY ANGLE	SPRAY PATTERN	CAPACITY (US) GPM AT PSI							
					5	10	15	20	30	35	40	60
005	UNI 50100	Grey	50°	Flat Spray	3.5	5.0	6.1	7.1	8.6	9.3	10.0	12.2
006	UNI 5070	Blue	50°	Flat Spray	2.5	3.5	4.3	4.9	6.1	6.6	7.0	8.6
007	UNI 5060	Orange	50°	Flat Spray	2.1	3.0	3.7	4.2	5.2	5.6	6.0	7.3
008	UNI 5050	Pink	50°	Flat Spray	1.8	2.5	3.1	3.5	4.3	4.7	5.0	6.1
009	UNI 5040	Mauve	50°	Flat Spray	1.4	2.0	2.5	2.8	3.5	3.8	4.0	4.9
010	UNI 5030	Blue	50°	Flat Spray	1.1	1.5	1.8	2.1	2.6	2.8	3.0	3.7
011	UNI 5020	Lt. Green	50°	Flat Spray	0.7	1.0	1.2	1.4	1.7	1.9	2.0	2.5

### 3.6. Working conditions of pumps and nozzles, Power consumed

In this section we are going to describe the actual working conditions for each pump and its electric consumption.

#### Penguin P-5 series 5 Horsepower pump

The 5 HP pump is working in the chemical wash step. The system has 84 nozzles (UNI-SPRAY SYSTEMS, UNI 5040) distributed on 6 rows of 14 each one.

Figure 3 Penguin 5 HP Performance Chart

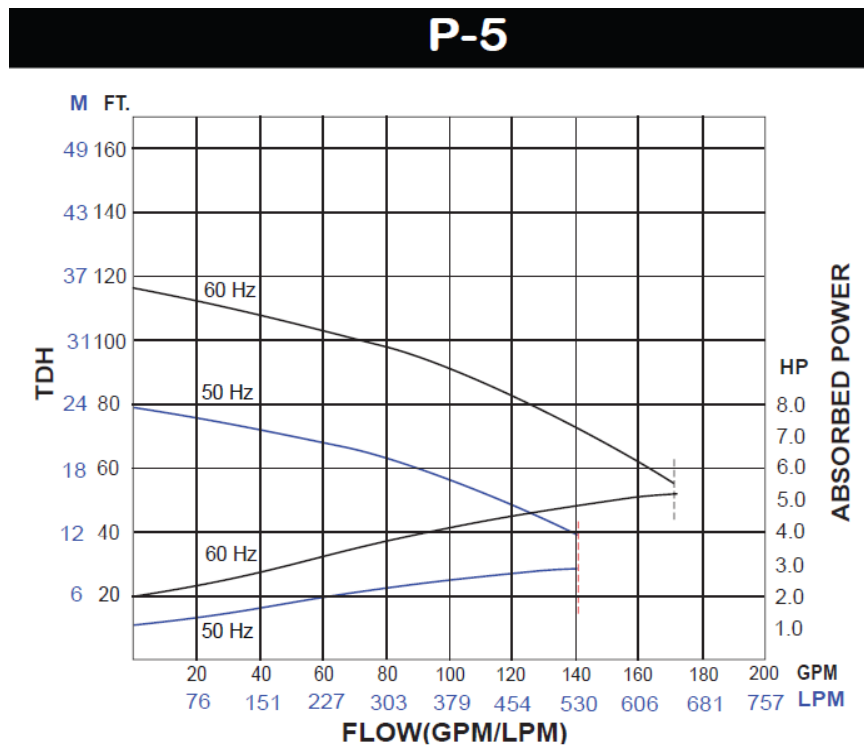
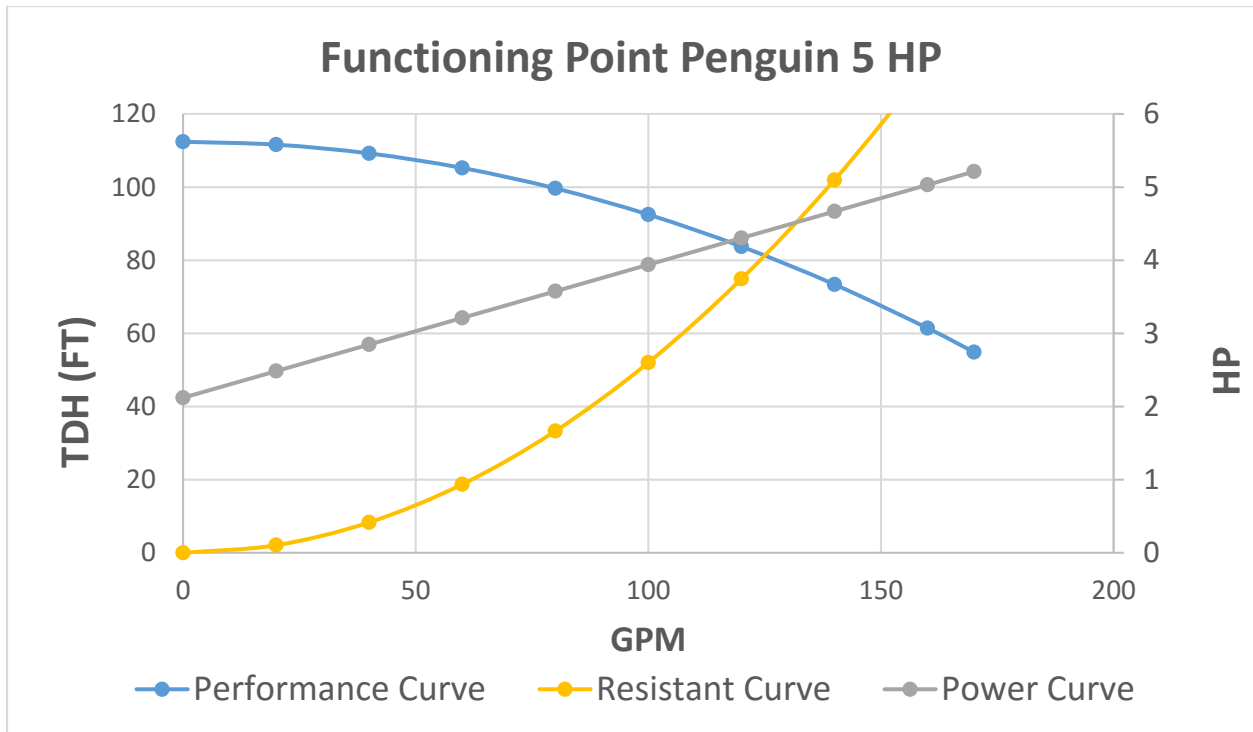

Figure 4 Functioning Point 5 HP pump



The Functioning Point of the pump is the intersection of the Performance and the Resistant Curve. We measured that the nozzles have a flow rate of 125 GPM and from the Performance Chart, the pump is working at a pressure of 81 FT. That will define the Functioning Point of the pump.

Under this conditions, looking at the Functioning Point the pump is actually consuming an approximated amount of 4.4 HP (3.3 KW).

## Penguin P-3 series 3 Horsepower pump

The 3 HP pump is working in the water wash step. The system has 36 nozzles for each pump (UNI-SPRAY SYSTEMS, UNI 5040) distributed on 6 rows of 6 each one.

Figure 5 Penguin 3 HP Performance Chart

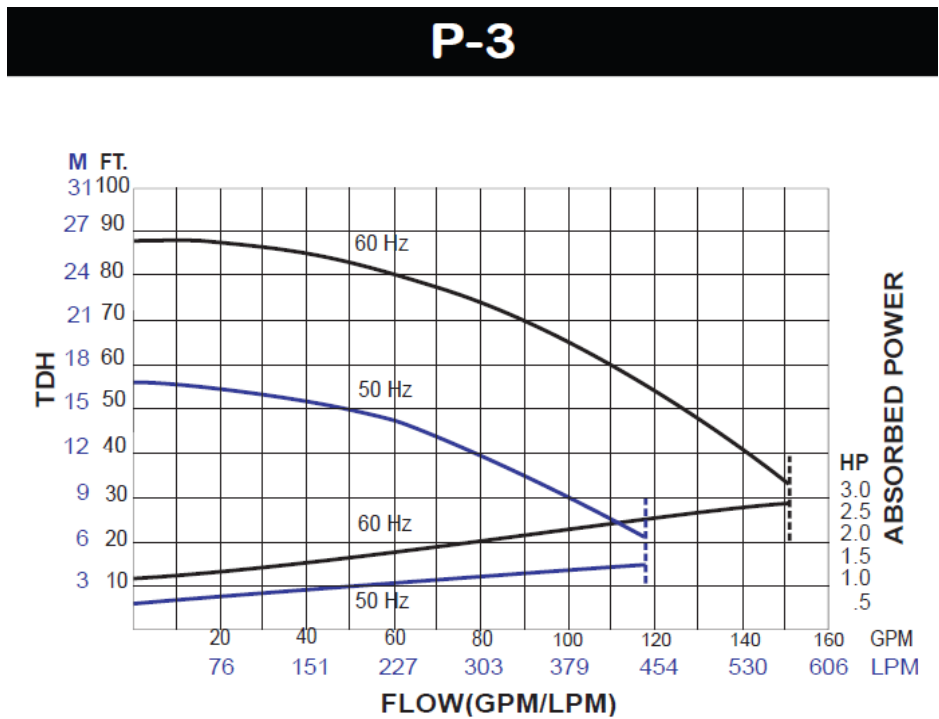
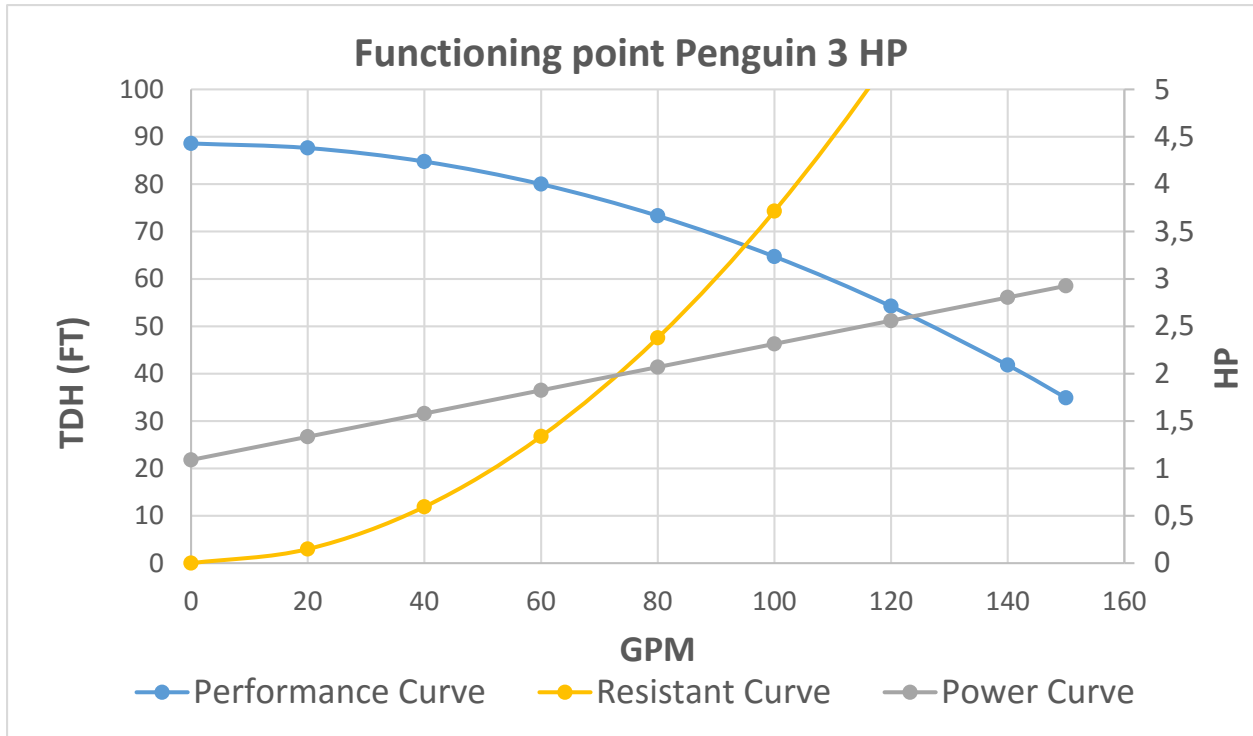

Figure 6 Functioning Point 5 HP pump



The Functioning Point of both 3 HP pumps now is defined by a flow rate of 95 GPM and from the Performance Chart, the pump is working at a pressure of 67 FT.

Under this conditions, looking at the Functioning Point the pump is actually consuming an approximated amount of 2.3 HP (1.7 KW).



**Table, summary of working conditions and power consumed**

*Table 4 Summary of working conditions*

	<b>Flow (GPM)</b>	<b>Pressure (FT head)</b>	<b>Power consumed HP (KW)</b>
<b>5 HP Pump</b>	125	81	4.4 (3.3)
<b>1<sup>st</sup> 3 HP Pump</b>	95	67	2.3 (1.7)
<b>2<sup>nd</sup> 3 HP Pump</b>	95	67	2.3 (1.7)

### 3.7. Pumps regulation with an AC drive

This is one of the most important sections. The comprehension on how to regulate the pumps will assure the best results on saving energy.

The regulation of the speed of a pump will always change the flow and the pressure that it gives. We have to be careful while regulating, as we want the pump to work in similar conditions while saving energy.

#### Penguin P-5 series 5 Horsepower pump

For starting the study, we have to define the functioning curve of the pump. From the performance chart in figure 1, we obtained that the curve for the 5 HP, working at 3450 rpm, 60 Hz is:

$$H = 112.40 - 0.002 * Q^2 \quad (1)$$

Where:  $H$  = Total Dynamic Head (FT)

$Q$  = Flow rate (GPM)

Note: Pressure (PSI) = 0.4335 H (FT)

As we are going to modify the speed of the pump, the next step is to find the expression for the pressure that the pump will give modifying the speed.

According to the pump Affinity Laws, the formula of the pressure that a pump can give only changing its speed is:

$$H' = \alpha^2 * A + B * Q'^2 \quad (2)$$

Where:  **$H'$  = Total Dynamic Head (FT) at new speed**

**$Q'$  = Flow rate (GPM) at new speed**

**$\alpha$  =  $N' / N_o$**

**$N'$  = New speed**

**$N_o$  = Original speed**

And the formula for the new power consumed:

$$P' = \alpha^3 * P_o \quad (3)$$

Where:  **$P'$  = Power consumed at new speed**

**$P_o$  = Power consumed at original speed**

**$\alpha$  =  $N' / N_o$**

**$N'$  = New speed**

**$N_o$  = Original speed**

Applying formulas (2) and (3) to our study we obtain that the pressure and power consumption for our 5 HP pump are:

Pressure:

$$H' = \left( \frac{N'(rpm)}{3450} \right)^2 * 112.40 - 0.002 * Q'^2 \quad (4)$$

Where:  **$H'$  = Total Dynamic Head (FT) at new speed**

**$Q'$  = Flow rate (GPM) at new speed**

**$N'$  = New speed (rpm)**

Power:

$$P' = \left( \frac{N'(rpm)}{3450} \right)^3 * P_o' \quad (5)$$

Where:  **$P'$  = Power consumed at new speed**

**$P_o'$  = Power consumed for new working conditions at original speed**

**$N'$  = New speed (rpm)**

Note: **As we are varying the Resistant Curve with the regulation valve  $P_o'$  is not directly equal to  $P_o$ . The excel file provided in the appendix will automatically calculate  $P_o'$  based on the new working conditions.**

### **Penguin P-3 series 3 Horsepower pump**

Following the same procedure as we did before, we have to define the functioning curve of the pump again. From the performance chart in figure 2, we obtained that the curve for the 3 HP, working at 3450 rpm, 60 Hz is:

$$H = 88.59 - 0.0024 * Q^2 \quad (6)$$

Where:  **$H$  = Total Dynamic Head (FT)**

**$Q$  = Flow rate (GPM)**

Note: **Pressure (PSI) = 0.4335 H (FT)**

Again, applying the Pump Affinity Laws described and using equations (2) and (3) in our study, we obtain that pressure and power consumption for our 3 HP pump at the new speed are:

Pressure:

$$H' = \left( \frac{N'(rpm)}{3450} \right)^2 * 88.59 - 0.0024 * Q'^2 \quad (7)$$

Where:  **$H'$  = Total Dynamic Head (FT) at new speed.**

**$Q'$  = Flow rate (GPM) at new speed.**

**$N'$  = New speed (rpm)**

Power:

$$P' = \left( \frac{N'(rpm)}{3450} \right)^3 * P_o' \quad (8)$$

Where:  **$P'$**  = Power consumed at new speed

**$P_o'$**  = Power consumed for new working conditions at original speed

**$N'$**  = New speed (rpm)

Note: As we are varying the Resistant Curve with the regulation valve  $P_o'$  is not directly equal to  $P_o$ . The excel file provided in the appendix will automatically calculate  $P_o'$  based on the new working conditions.

### 3.8. Fan in Dust Collector in Powder Coating Process

The motor is right now running at full power, connected directly to the electric network. As mentioned before, the ventilator is located in the powder coating station.

A dust collector is a system used to enhance the quality of air released from industrial processes by collecting dust and other impurities from air. Designed to handle high-volume dust loads, a dust collector system consists of a blower, dust filter, a filter-cleaning system, and a dust receptacle or dust removal system. It is distinguished from air cleaners, which use disposable filters to remove dust.

Our dust collector system is based on Cartridge collectors, which use perforated metal cartridges that contain a pleated. The pleated design allows for a greater total filtering surface area than in a conventional bag of the same diameter and the greater filtering area results in a reduced air to media ratio, pressure drop, and overall collector size.

In the image 6 we can see an example of cartridges.

Cartridge collectors are available in single use or continuous duty designs. Boyko's Metal Finishing Co. has continuous production, so the cartridges are cleaned by the conventional pulse-jet cleaning system.

*Image 6 Cartridges for powder coating*



Pulse jet baghouse dust collectors are used when it is impractical to shut down your dust collector to clean the filter bags. A pulse of compressed air is blasted through the filter bags to blow loose the built up particles on the filter bags to maintain optimum filtration efficiency

In a pulse jet fabric filter, a wire cage in each bag keeps it from collapsing during normal filtration.

As the flue gas passes from the outside of the bag through the fabric, the particulate forms a cake on the surface of the bag. Cleaning the filter bags is accomplished by introducing controlled pulses of compressed air into each filter bag through a blowpipe and orifice assembly mounted just above the filter bag. These short-duration pulses of air exit the blowpipe orifices and travel down the filter bags. The accumulated dust cake is dislodged by the resulting shock wave and falls into the hoppers.

In the image 7, it is possible to see a schema of the process.

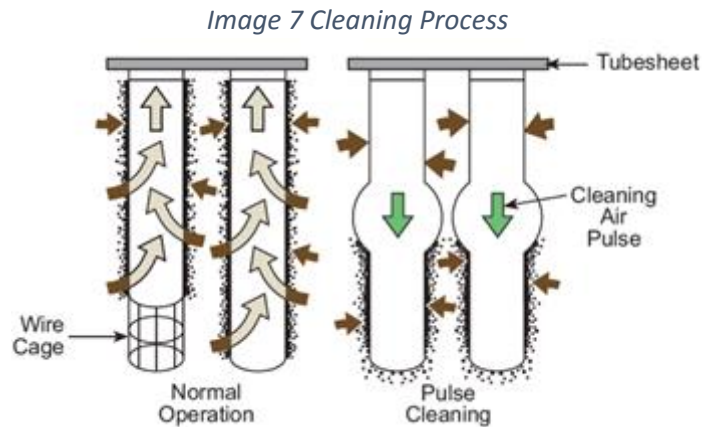



### **3.9. AC Drive chosen**

For Boyko's Metal Finishing Co, we recommend the use of an AC Driver of ABB because they offer technical support during the installation and maintenance, also it is a global leader in power and automation technologies. Their solutions improve the efficiency, productivity and quality of their customers' operations while minimizing environmental impact.

There are two options for Boyko's Metal Finishing, on one hand the AC Drive ACS310-03U-41A8-4 R4 J400 would fit Boyko's necessities because it can control different pumps and fans at the same time, giving also a percentage of savings in real-time.

On the other hand, it is possible to install different AC Drives for the different pumps and fan. This would give the advantage of independent control of the pumps and fan, there would be four AC Drives.

According to the voltage range and the horse power needed to control the fan and both pumps, from the ABB General Purpose Drives ACS310 Catalog, it is possible to select the appropriate AC Drive for the system.

Table 5 Characteristics of different types

	Ratings				Type designation	Frame size
	$P_n$ hp	$P_n$ kW	$I_1$ 2N (A)	$I_2$ 2N (A)		
1-phase AC supply, 200 to 240 V	0,5	0,37	2,4	2,3	ACS310-01U-02A4-2	R0
	1	0,75	4,7	4,5	ACS310-01U-04A7-2	R1
	1,5	1,1	6,7	6,5	ACS310-01U-06A7-2	R1
	2	1,5	7,5	7,2	ACS310-01U-07A5-2	R2
	3	2,2	9,8	9,4	ACS310-01U-09A8-2	R2

3-phase AC supply, 200 to 240 V	0,5	0,37	2,6	2,4	ACS310-03U-02A6-2	R0
	0,75	0,55	3,9	3,5	ACS310-03U-03A9-2	R0
	1	0,75	5,2	4,7	ACS310-03U-05A2-2	R1
	1,5	1,1	7,4	6,7	ACS310-03U-07A4-2	R1
	2	1,5	8,3	7,5	ACS310-03U-08A3-2	R1
	3	2,2	10,8	9,8	ACS310-03U-10A8-2	R2
	5	4	19,4	17,6	ACS310-03U-19A4-2	R2
	7,5	5,5	26,8	24,4	ACS310-03U-26A8-2	R3
	10	7,5	34,1	31	ACS310-03U-34A1-2	R4
15	11	50,8	46,2	ACS310-03U-50A8-2	R4	

3- phase AC supply, 380 to 480 V	0.5	0.37	1.3	1.2	ACS310-03U-01A3-4	R0
	0.75	0.55	2.1	1.9	ACS310-03U-02A1-4	R0
	1.0	0.75	2.6	2.4	ACS310-03U-02A6-4	R1
	1.5	1.1	3.6	3.3	ACS310-03U-03A6-4	R1
	2.0	1.5	4.5	4.1	ACS310-03U-04A5-4	R1
	3.0	2.2	6.2	5.6	ACS310-03U-06A2-4	R1
	5.0	4.0	9.7	8.8	ACS310-03U-09A7-4	R1
	7.5	5.5	13.8	12.5	ACS310-03U-13A8-4	R3
	10.0	7.5	17.2	15.6	ACS310-03U-17A2-4	R3
	15.0	11.0	25.4	23.1	ACS310-03U-25A4-4	R3
	20.0	15.0	34.1	31	ACS310-03U-34A1-4	R4
	25.0	18.5	41.8	38	ACS310-03U-41A8-4	R4
	30.0	22.0	48.4	44	ACS310-03U-48A4-4	R4

As the pumps need 5, 3 and 3 horse power and the fan 10 horse power, we would need 21 horse power. From the table we found out that there are three interesting options for Boyko’s Metal Finishing.

The **first one** is using just one AC Drive to use the pumps and fan, the model we need is ACS310-03U-41A8-4 R4, which can work up to 25 horse power.

For the **second option**, we would need:

- For the 10 HP fan would be ACS310-03U-17A2-4 R3.
- For the 5 HP pump would be ACS310-03U-09A7-4 R1
- For the two 3 HP pumps would be ACS310-03U-06A2-4 R1

The **third option** would be adding the assistant panel to the Drives used in the second option, which would be more expensive but will facilitate its use and control.

The costs for the AC Drives is shown below:

*Table 6 Options and prices for Boyko's Metal Finishing Co.*

	Model	Max HP	Quantity	Price per unit
Option 1	ACS310-03U-41A8-4 R4	25	1	\$ 1,025.40
			Total price	\$ 1,025.40
Option 2	ACS310-03U-17A2-4 R3	10	1	\$ 520.20
	ACS310-03U-09A7-4 R1	5	1	\$ 363.60
	ACS310-03U-06A2-4 R1	3	2	\$ 304.20
			Total price	\$ 1,492.20
Option 3	ACS310-03U-17A2-4 R3 J400	10	1	\$ 610.20
	ACS310-03U-09A7-4 R1 J400	5	1	\$ 453.60
	ACS310-03U-06A2-4 R1 J400	3	2	\$ 394.20
			Total price	\$ 1,852.20

Due to Boyko’s preferences, it would be better the second option with those four AC Drives.

### 3.10. Installation of the AC Drive

For installing an AC drive, first of all we have to read the precautions and general information about it. It includes very important information about safety, qualified personnel, personal safety and product safety are the most important points.

Qualified personnel on adjusting frequency AC drives and associated machinery is essential to plan, implement the installation, startup and maintenance because any failure in this processes can result in injuries to the workers and/or machinery damage.

Personal Safety is referred to some prevention actions to avoid electric shock hazard, equipment damage. To avoid an electric shock hazard, verify that the voltage on the bus capacitors has discharged before performing any work on the drive. The voltage must be zero.

The steps for the installation of this AC drive are the following:

- Mechanical Installation
- Electrical Installation
- Start-up and control with I/O
- Additional functions

## Mechanical Installation

During the mechanical installation we have to check the installation site, the drive may be installed on the wall or in a cabinet. The drive can be installed in three different ways, depending on the frame size:

- Back mounting (all frame sizes)
- Side mounting (frame sizes R0...R2)
- DIN rail mounting (all frame sizes).

There are also some requirements for the walls and floor around it.

The wall should be as close to vertical and even as possible, of non-flammable material and strong enough to carry the weight of the drive.

The material of the floor below the installation should be non-flammable.

The required free space for cooling above and below the drive is 75 mm (3 in). No free space is required on the sides of the drive, so drives can be mounted immediately next to each other.

After everything has been checked, we can proceed to the installation. Which is going to be started with the **screws**.

1. Mark the hole locations using for example the mounting template cut out from the package. The number and location of the holes used depend on how the drive is installed:
  - a. back mounting (frame sizes R0...R4): four holes
  - b. Side mounting (frame sizes R0...R2): three holes; one of the bottom holes is located in the clamping plate.
2. Fix the screws or bolts to the marked locations.

*Image 8 Steps 1 and 2 of the mechanical installation*

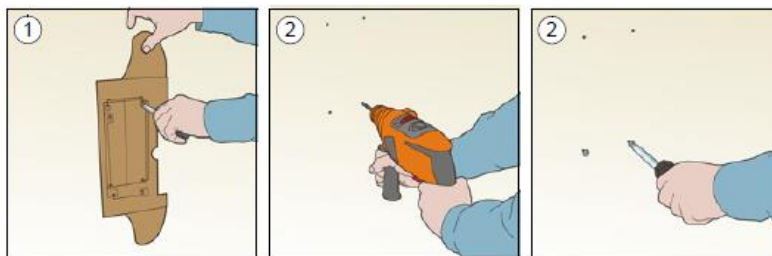

3. Position the drive onto the screws on the wall.
4. Tighten the screws in the wall securely.

*Image 9 Steps 3 and 4 of the mechanical installation*

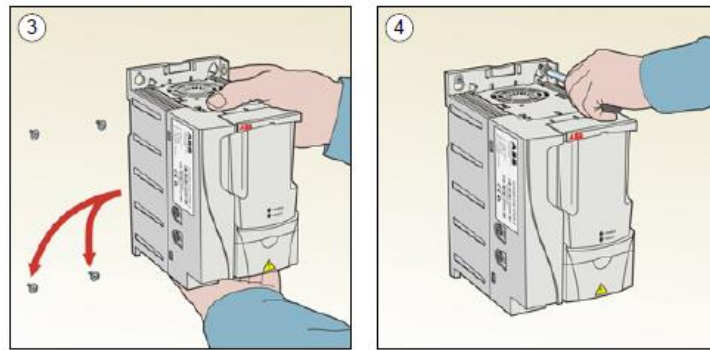

After this, it is time to continue with the DIN rail.

1. Click the drive to the rail. To detach the drive, press the release lever on top of the drive (1b).

*Image 10 First step for the DIN rail*

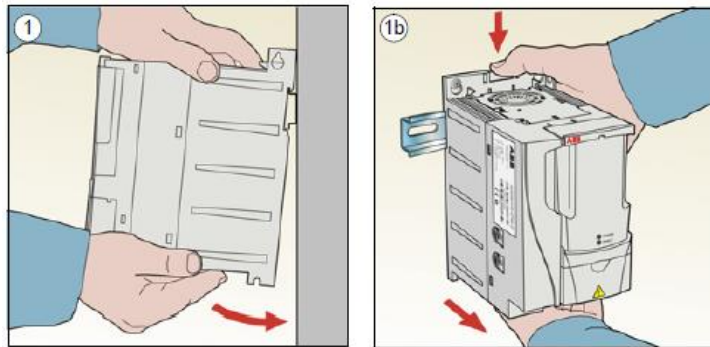

Then, fasten clamping plates

2. Fasten the clamping plate to the plate at the bottom of the drive with the provided screws.
3. For frame sizes R0...R2, fasten the I/O clamping plate to the clamping plate with the provided screws.

*Image 11 Second and third step for the DIN rail*

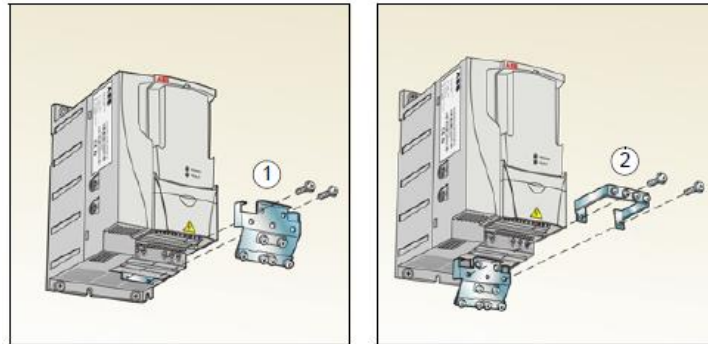

## Electrical installation

As we did before the mechanical installation, we have to check the compatibility of the motor and drive, and selecting cables, protections, cable routing and way of operation for the drive.

Implementing the AC power line connection is a must because the leakage current of the device typically exceeds 3.5 mA, so a fixed installation is required according to IEC 61800-5-1

In addition, a hand-operated supply disconnecting device should be installed between the AC power source and the drive. The disconnecting device must be of a type that can be locked to the open position for installation and maintenance work and do not forget that the disconnecting device must conform to the applicable safety regulations.

Selecting the adequate power cables according to local regulations is essential, because of that, here there are some instructions to follow:

- The input power and the motor cables must be able to carry the corresponding load currents
- The cable must be rated for at least 70 °C maximum permissible temperature of the conductor in continuous use.
- Where conduits must be coupled together, bridge the joint with a ground conductor bonded to the conduit on each side of the joint. Bond the conduits also to the drive enclosure. Use separate conduits for input power, motor and control wiring. Do not run motor wiring from more than one drive in the same conduit.
- The power cables must be rated for 75 °C (167 °F).
- The conductivity of the PE conductor must be equal to that of the phase conductor.



For the control cables, there are different instructions due to its finality.

- Employ one individually shielded pair for each signal. Do not use common return for different analog signals.
- Run analog and digital signals in separate cables.
- It is recommended that the relay-controlled signals are run as twisted pairs.
- In remote use, the cable connecting the control panel to the drive must not exceed 3 m (10 ft.). The cable type tested and approved by ABB is used in control panel option kits.

For routing the cables, ABB provides some recommendations as:

- It is recommended that the motor cable, input power cable and control cables are installed on separate trays. Avoid long parallel runs of motor cables with other cables to decrease electromagnetic interference caused by the rapid changes in the drive output voltage.
- Where control cables must cross power cables make sure that they are arranged at an angle as near to 90 degrees as possible.
- The cable trays must have good electrical bonding to each other and to the grounding electrodes.

Before connecting any cable:

- Check the insulation of the motor and motor cable.
- Checking the compatibility with IT (ungrounded) and corner-grounded TN systems

The electrical connection procedure for the power cables is:

1. Fasten the grounding conductor (PE) of the input power cable under the grounding clamp. Connect the phase conductors to the U1, V1 and W1 terminals.
2. Strip the motor cable and twist the shield to form as short a pigtail as possible. Fasten the twisted shield under the grounding clamp. Connect the phase conductors to the U2, V2 and W2 terminals.
3. Secure the cables outside the drive mechanically.

Image 12 Steps for the electrical installation

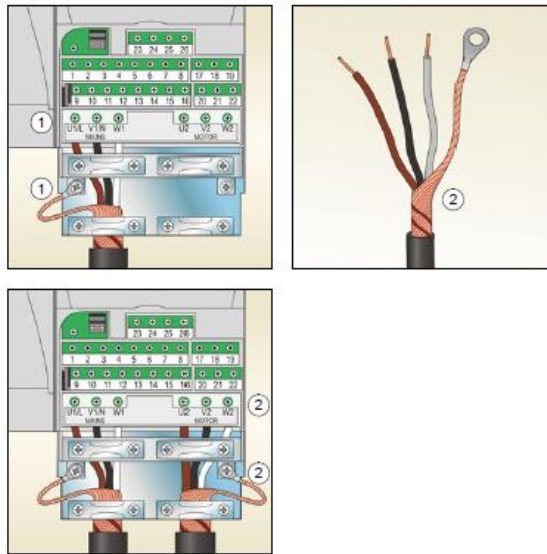
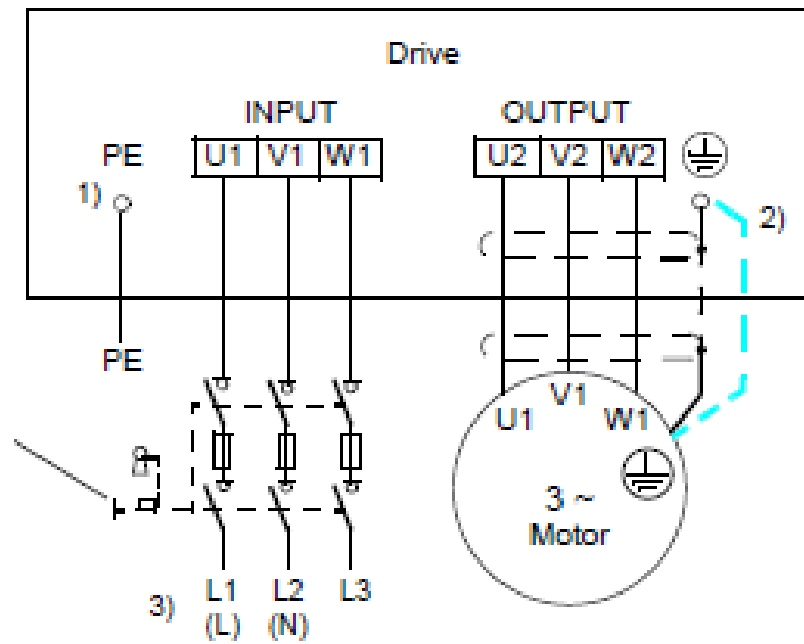

Image 13 Connection Diagram.



1. Ground the other end of the PE conductor at the distribution board.
2. Use a separate grounding cable if the conductivity of the cable shield is insufficient and there is no symmetrically constructed grounding conductor in the cable.
3. L and N are connection markings for 1-phase supply.

For the **I/O connection diagram**, the default connection of the control signals depends on the application macro in use. The default macro is the ABB standard macro. It provides a general purpose I/O configuration with three constant speeds.

The default I/O connections for the ABB standard macro are given in the figure below.

Image 14 Default I/O connections for the ABB standard macro

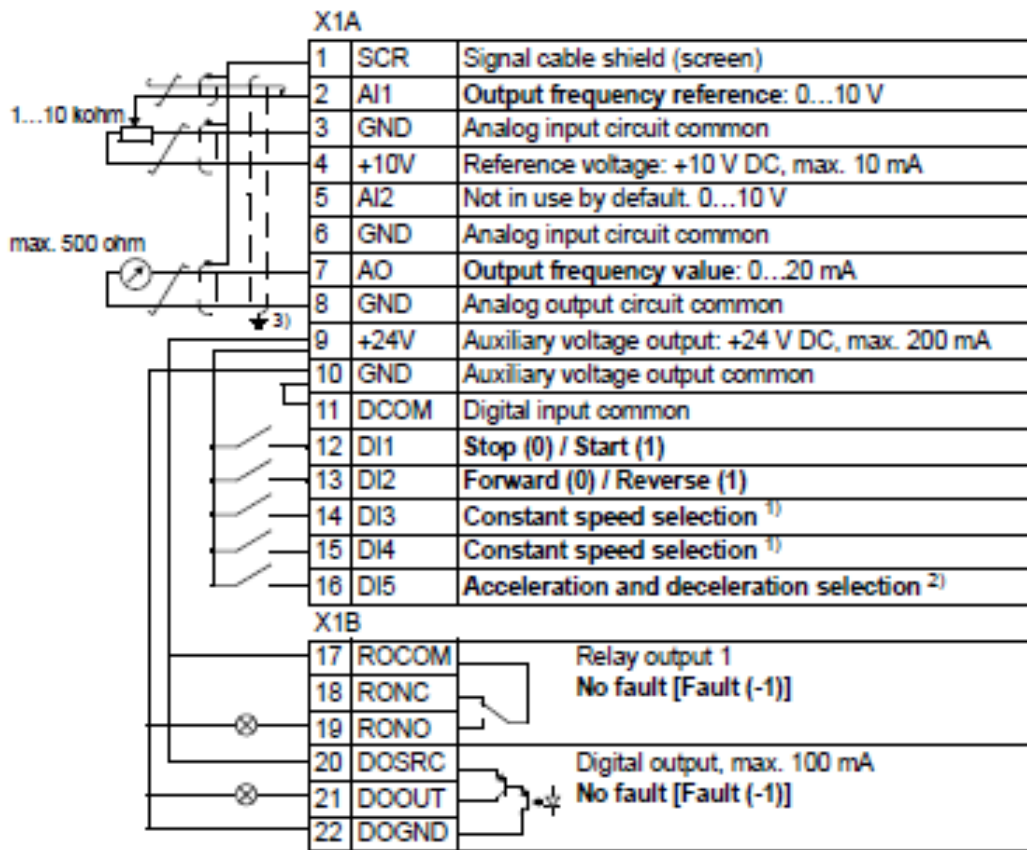

<sup>1)</sup> See parameter group **12 CONSTANT SPEEDS**:

DI3	DI4	Operation (parameter)
0	0	Set speed through AI1
1	0	Speed 1 (1202 CONST SPEED 1)
0	1	Speed 2 (1203 CONST SPEED 2)
1	1	Speed 3 (1204 CONST SPEED 3)

<sup>2)</sup> 0 = ramp times according to parameters 2202 and 2203.

1 = ramp times according to parameters 2205 and 2206.

<sup>3)</sup> 360 degree grounding under a clamp.  
Tightening torque: 0.4 N·m (3.5 lbf·in).

The electrical connection procedure for the control cables is:

1. Remove the terminal cover by simultaneously pushing the recess and sliding the cover off the frame.
2. Digital signals: Strip the outer insulation of the digital signal cable 360 degrees and ground the bare shield under the clamp.
3. Connect the conductors of the cable to the appropriate terminals. Use a tightening torque of 0.4 N·m (3.5 lbf·in).
4. For double-shielded cables, twist also the grounding conductors of each pair in the cable together and connect the bundle to the SCR terminal (terminal 1).

*Image 15 Steps 1, 2, 3 and 4 of the electrical connection for the control cables*

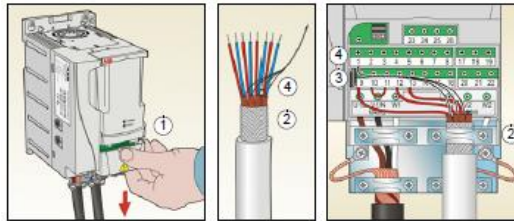

5. Analog signals: Strip the outer insulation of the analog signal cable 360 degrees and ground the bare shield under the clamp.
6. Connect the conductors to the appropriate terminals. Use a tightening torque of 0.4 N·m (3.5 lbf·in).
7. Twist the grounding conductors of each pair in the analog signal cable together and connect the bundle to the SCR terminal (terminal 1).
8. Secure the connected cables outside the drive mechanically.
9. Slide the terminal cover back in place.

*Image 16 Steps 5,6, 7, 8 and 9 of the electrical connection for the control cables*

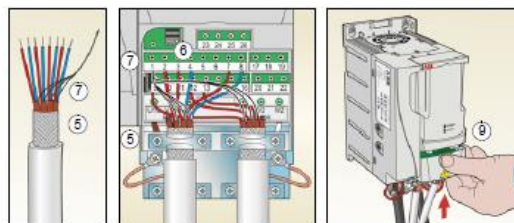

## Start-up and control with I/O

The drive starts up automatically at power up if the external run command is on and the drive is in the remote control mode.

There are different ways of set-up depending on the type of control panel that we decide to add to our AC drive. Due to the need to modify parameters we have thought that the best option would be an Assistant Control Panel, it also offers the possibility of switching between local and remote control.

There are nine modules in this control panel: Output mode, Parameter mode, Assistants mode, Changed parameters mode, Fault logger mode, Time and date mode, Parameter backup mode, IO settings mode and Fault mode. When a fault or alarm occurs, the panel goes automatically to the Fault mode showing the fault or alarm. You can reset it in the Output or Fault mode.

In the Output mode, you can:

- monitor actual values of up to three signals in group 01 OPERATING DATA
- change the direction of the motor rotation
- set the frequency reference
- adjust the display contrast
- Start, stop, change the direction and switch between local and remote control.

In the Parameters mode, you can:

- view and change parameter values
- Start, stop, change the direction and switch between local and remote control.

When the drive is first powered up, the Start-up assistant guides you through the setup of the basic parameters. The Start-up assistant is divided into assistants, each of which is responsible for the specification of a related parameter set. The Start-up assistant activates the assistants one after the other. You may also use the assistants independently.

In the Assistant mode, you can:

- Use assistants to guide you through the specification of a set of basic parameters.
- Start, stop, change the direction and switch between local and remote control.

In the Changed parameters mode, you can:

- View a list of all parameters that have been changed from the macro default values.
- Change these parameters.
- Start, stop, change the direction and switch between local and remote control.

In the Fault logger mode, you can:

- View the drive fault history of maximum ten faults.
- See the details of the three latest faults.
- Read the help text for the fault.
- Start, stop, change the direction and switch between local and remote control.

In the Time and date mode, you can:

- Show or hide the clock
- Change date and time display formats
- Set the date and time
- Enable or disable automatic clock transitions according to the daylight saving changes
- Start, stop, change the direction and switch between local and remote control.

The Assistant control panel contains a battery to ensure the function of the clock when the panel is not powered by the drive.

The Parameter backup mode is used to export parameters from one drive to another or to make a backup of the drive parameters. Uploading to the panel stores all drive parameters, including up to two user sets, to the Assistant control panel. The full set, partial parameter set (application) and user sets can then be downloaded from the control panel to another drive or the same drive. Uploading and downloading can be performed in local control.

In the IO settings mode, you can:

- Check the parameter settings related to any I/O terminal
- Edit the parameter setting
- Start, stop, change the direction and switch between local and remote control.

This device has also the possibility of **macros**.

Application macros are pre-programmed parameter sets. While starting up the drive, the user typically selects one of the macros.

We recommend to use ABB standard macros but it is possible to make your own ones. ABB standard macros can be used in applications in which up to three constant speeds are used. Start/stop is controlled

with one digital input (level start and stop). It is possible to switch between two acceleration and deceleration times.

Two of the most important functions of this AC Drive are the **Energy optimizer and Energy savings**.

On one hand, the Energy optimizer optimizes the flux so that the total energy consumption and motor noise level are reduced when the drive operates below the nominal load. The total efficiency (motor and drive) can be improved by 1...10% depending on the load torque and speed.

On the other hand, Energy saving tools calculate energy saved in kWh and MWh, energy saved in local currency as well as reduction in CO2 emission, all compared to the situation when the pump is connected directly to the supply.

Another application of the modules of this ACS310 is the **Pump cleaning function** can be used for preventing solids from building up on pump impellers. The function consists of a programmable sequence of forward and reverse runs of the pump (see the figure below), effectively shaking off any residue on the impeller.

*Image 17 Function of pump cleaning function*

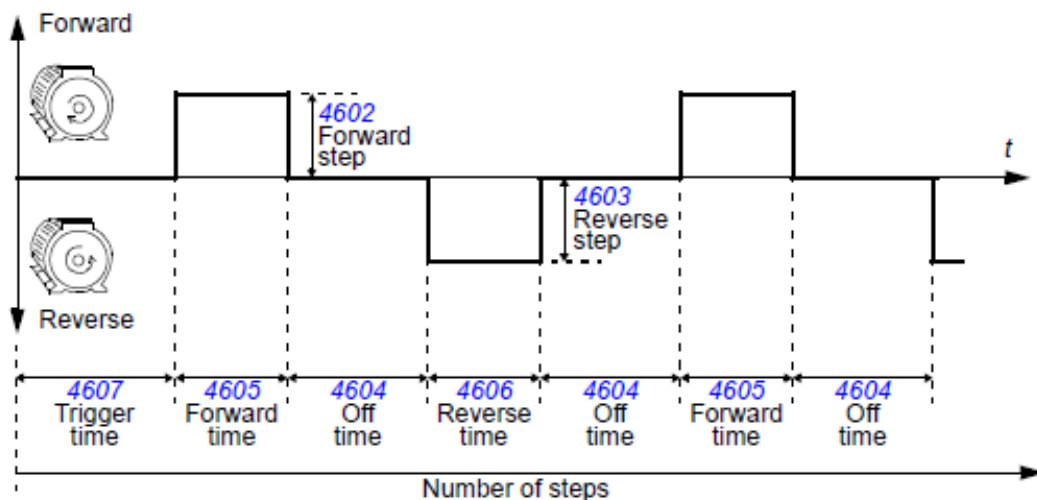

This cycle can be activated at start-up, with a user-defined period, with a selectable digital input or by the Supervision function

For a better understanding of each module go to the appendix

When the installation is finished, check if something could happen to the AC drive for additional safety measures.



### 3.11. Maintenance intervals

If installed in an appropriate environment, the drive requires very little maintenance. The table lists the routine maintenance intervals recommended by ABB.

*Table 7 Maintenance intervals*

Maintenance	Interval
Reforming of capacitors	Every year when stored
Check of dustiness, corrosion and temperature	Every year
Cooling fan replacement (frame sizes R1 to R2)	Every three years
Check and tightening of the power terminals	Every six years
Replace of the battery in the Assistant control panel	Every ten years

The **capacitors** must be reformed if the drive has been stored for a year.

The **power connections** must be done following the next sequence:

1. Stop the drive and disconnect it from the power line. Wait for five minutes to let the drive DC capacitors discharge. Ensure by measuring with a multimeter (impedance at least 1 Mohm) that there is no voltage present.
2. Check the tightness of the power cable connections. Use the tightening torques given in section Terminal and lead-through data for the power cables.
3. Restore power.

The life span of the drive's **cooling fan** depends on the drive usage and ambient temperature. When the Assistant control panel is in use, the Notice handler assistant informs when the definable value of the operating hour counter is reached.

Fan failure can be predicted by the increasing noise from the fan bearings. If the drive is operated in a critical part of a process, fan replacement is recommended once these symptoms start appearing.

These are the instructions for replacing the cooling fan:

1. Stop the drive and disconnect it from the power line. Wait for five minutes to let the drive DC capacitors discharge. Ensure by measuring with a multimeter (impedance at least 1 Mohm) that there is no voltage present.
2. Remove the hood if the drive has the NEMA 1 option.
3. Lever the fan holder off the drive frame with, for example, a screwdriver.
4. Free the fan cable from the clip in the drive frame.
5. Lift the holder from the hinges.

*Image 18 Instructions 3, 4 and 5 for replacing the cooling fan*

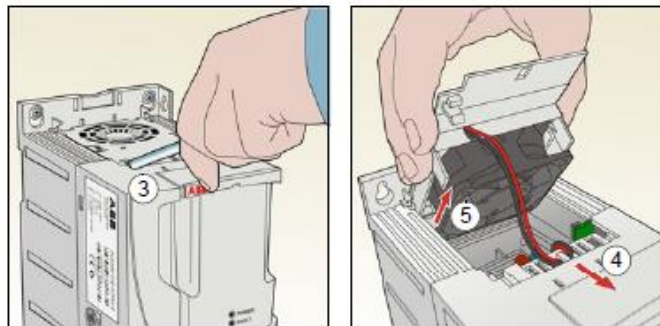

6. Disconnect the fan cable. The figure below on the right shows the location of the fan cable connector in frame size R2. The inside views in different frame sizes are not identical, but the fan cable connector is always on the control board that is against the front of the drive.

*Image 19 Illustration of Instruction 6 for replacing the cooling fan*

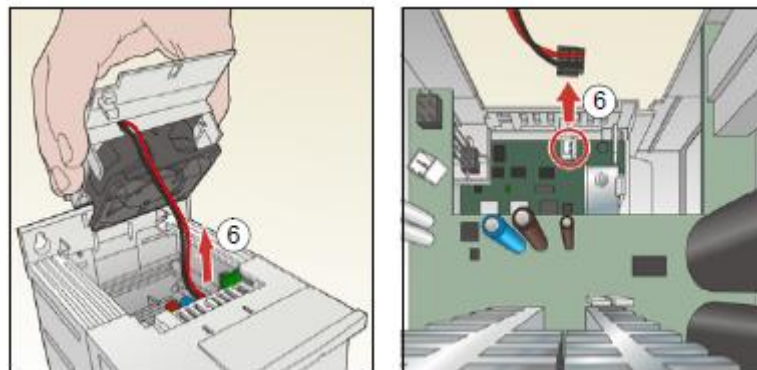

7. Free the fan cable from the clip in the fan holder.

8. Remove the fan from the holder.

*Image 20 Illustration of Instruction 7 and 8 for replacing the cooling fan*

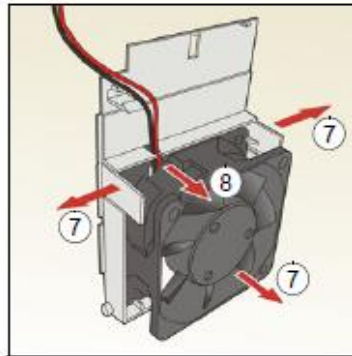

9. Install the new fan in reverse order.
10. Restore power.

For **the control panel**, there are two actions to be done: cleaning the control panel and changing the battery in the Assistant control panel.

— Cleaning the control panel

Use a soft damp cloth to clean the control panel. Avoid harsh cleaners which could scratch the display window.

— Changing the battery in the Assistant control panel

A battery is only used in Assistant control panels that have the clock function available and enabled. The battery keeps the clock operating in memory during power interruptions. The expected life for the battery is greater than ten years. To remove the battery, use a coin to rotate the battery holder on the back of the control panel. Replace the battery with type CR2032.

Note: The battery is NOT required for any control panel or drive functions, except the clock.

### **3.12. Return on Investment on adding AC Drives to the actual process**

The time that will be necessary for recovering the initial investment of the installation of the AC drives depends on the exact functioning point of each pump and the fan. The exact Return on Investment can be exactly calculated with the excel file provided once we know all the parameters of the installation and functioning point.

The new functioning point will depend on Mr. Boyko's criteria, so we are going to develop 2 conservative scenarios where we are going to assume those parameters based on previous experiences, other projects and Mr. Boyko's thoughts about how the regulation will be done.

The first scenario will present the worst conditions, so that means we are going to calculate the maximum time for recovering the investment and how much money we are saving.

The second scenario will present the best conditions, so that means we are going to calculate the minimum time for recovering the investment and how much money we are saving.

The realistic Return on Investment should be somewhere in the middle of those two scenarios, depending on the final working conditions.

## First scenario

In this scenario we are going to present the worst new functioning conditions. The pumps will function in a very close point to the original one, so the energy reduced will be low. Also, we are going to assume that the fan consumption will be reduced a 20%, that is also a low value. Then:

- **New Functioning Point Penguin P-5 5 HP**

Figure 7 New Functioning Point P-5 5 HP

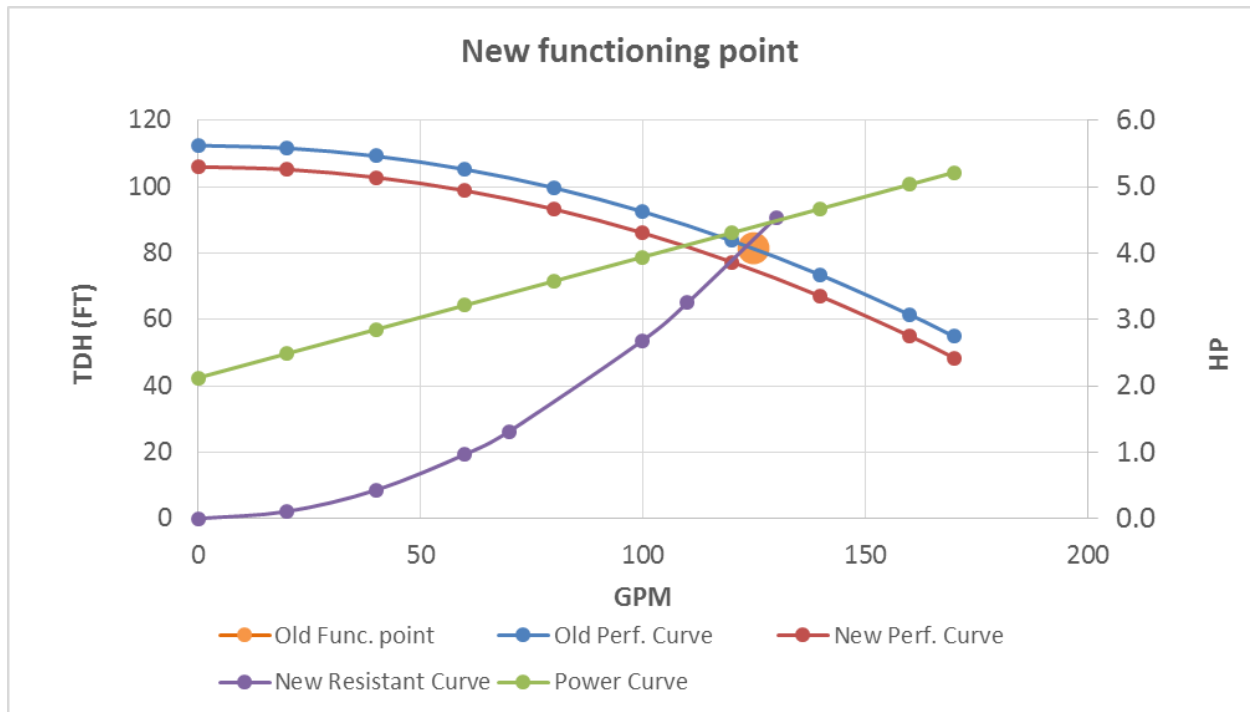

Again, the new Functioning Point is located in the intersection of the New Resistant Curve and the New Performance curve. Old Functioning Point is also illustrated for its comparison of working conditions:

*Table 8 New working conditions and energy saved*

<b>New working conditions</b>	
New speed pump (rpm)	3350 rpm
New flow (GPM)	120 gpm
<b>Results</b>	
Original Power Consumed	4.4 HP
New Power consumed	4.0 HP
% Energy saved	9%

- **New Functioning Point Penguin P-3 3 HP**

Figure 8 New Functioning Point P-3 3 HP

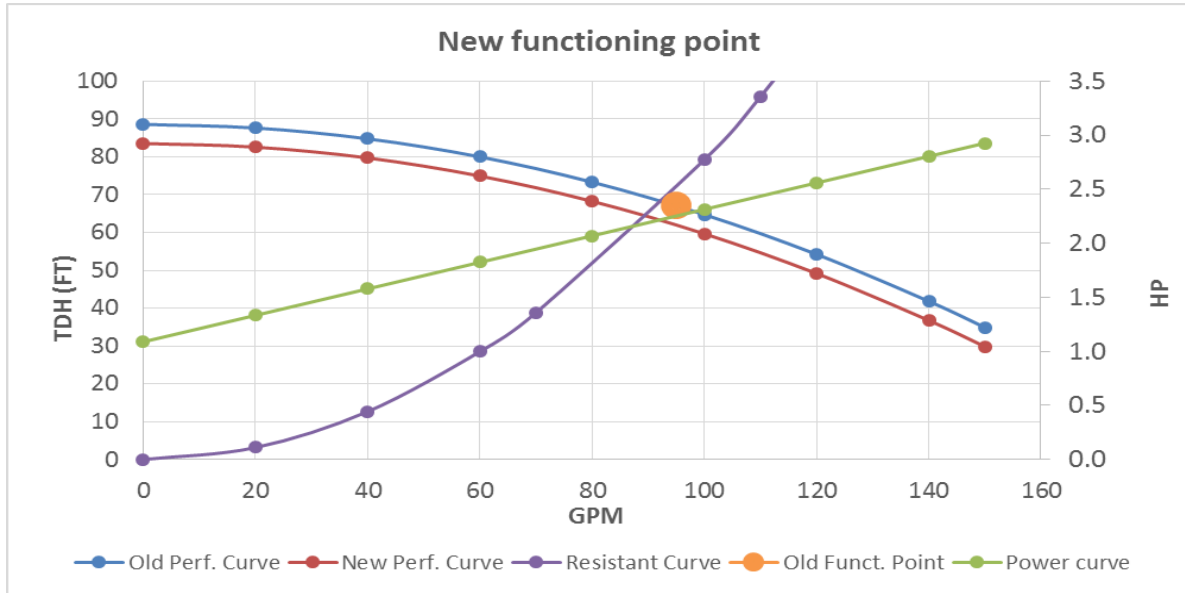

Also, the new working conditions:

Table 9 New working conditions and energy saved

<b>New working conditions</b>	
New speed pump (rpm)	3350 rpm
New flow (GPM)	90 gpm
<b>Results</b>	
Original Power Consumed	2.3 HP
New Power consumed	2.0 HP
% Energy saved	10%

Under this working conditions, we calculated the Return on Investment:

*Table 10 Conditions for Return on Investment*

Energy		Work		Initial costs	
Original Power 5 HP	3.28 KW	Hours working per day	16 OK	AC drives cost	1600 \$
Energy saved 5 HP	9%	Days working per month	22 OK	Others (electrician, ...)	400 \$
Original Power 3 HP	1.68 KW			Total	2000 \$
Energy saved 3 HP	10%				
Original Power 10 HP	7.46 KW				
Energy saved 10 HP	20%				
KWh price	0.0961 \$				

*Table 11 Results of Return on Investment*

Results	
Original cost per day	21.7 \$/day
New cost per day	18.4 \$/day
Saves per day	3.2 \$/day
Saves per month	71.3 \$/month
Break even point	28 months

We appreciate that under this conditions the initial investment will be recovered in 28 months, and from that we will save \$71.3 per month, that means **\$856 per year**.



## Second scenario

In this scenario we are going to present the best new functioning conditions. The pumps will function in a close point to the original one, but the amount of energy consumed will be more reduced. Also, we are going to assume that the fan consumption will be reduced a 40%, an average value based on the application. Then:

### - New Functioning Point Penguin P-5 5 HP

Figure 9 New Functioning Point P-5 5 HP

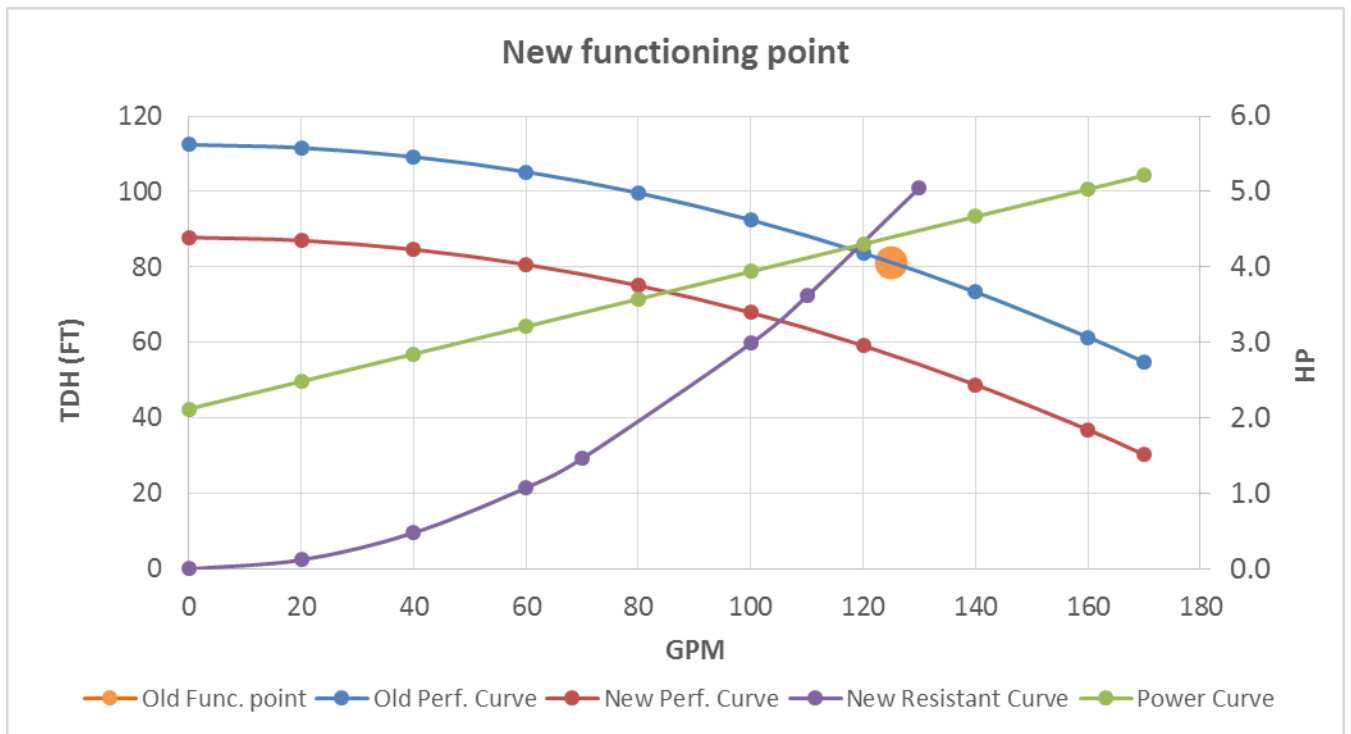

Again, the new Functioning Point is located in the intersection of the New Resistant Curve and the New Performance curve. Old Functioning Point is also illustrated for its comparison of working conditions:

*Table 12 New working conditions and energy saved*

<b>New working conditions</b>	
New speed pump (rpm)	3050 rpm
New flow (GPM)	105 gpm
<b>Results</b>	
Original Power Consumed	4.4 HP
New Power consumed	3.0 HP
% Energy saved	33%

- **New Functioning Point Penguin P-3 3 HP**

Figure 10 New Functioning Point P-3 3 HP

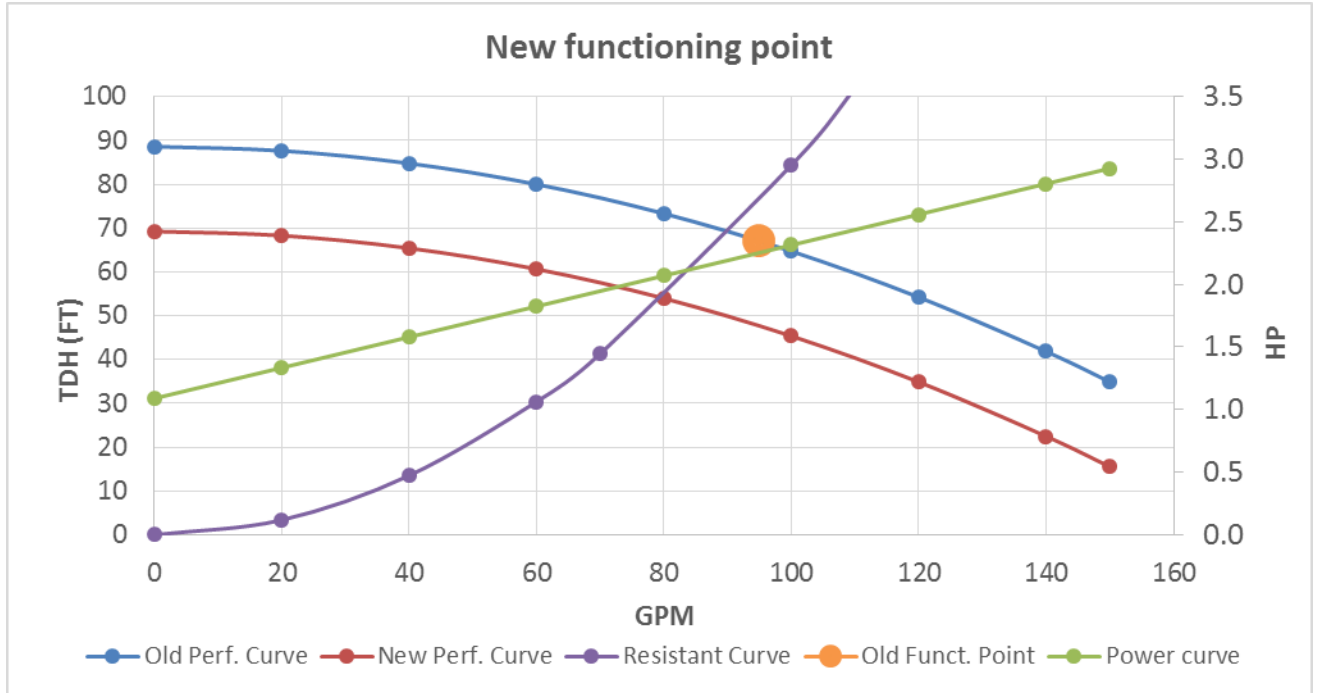

Also, the new working conditions:

Table 13 New working conditions and energy saved

<b>New working conditions</b>	
New speed pump (rpm)	3050 rpm
New flow (GPM)	80 gpm
<b>Results</b>	
Original Power Consumed	2.3 HP
New Power consumed	1.5 HP
% Energy saved	33%

Under this working conditions, we calculated the Return on Investment:

*Table 14 Conditions for Return on Investment*

Energy		Work		Initial costs	
Original Power 5 HP	3.28 KW	Hours working per day	16 OK	AC drives cost	1600 \$
Energy saved 5 HP	33%	Days working per month	22 OK	Others (electrician, ...)	400 \$
Original Power 3 HP	1.68 KW			Total	2000 \$
Energy saved 3 HP	33%				
Original Power 10 HP	7.46 KW				
Energy saved 10 HP	40%				
KWh price	0.0961 \$				

*Table 15 Results of Return on Investment*

Results	
Original cost per day	21.7 \$/day
New cost per day	13.8 \$/day
Saves per day	7.9 \$/day
Saves per month	174.2 \$/month
Break even point	11 months

We appreciate that under this conditions the initial investment will be recovered in 11 months, and from that we will save \$174 per month, that means **\$2088 per year**.

## Summary of Return on Investment

As mentioned before, the new functioning point will depend on Mr. Boyko's criteria, so the realistic Return on Investment should be somewhere in the middle of the two scenarios developed before, depending on the final working conditions.

We have not considered rebates on this chapter, as they depend on the audition of PSE&G after the installation. It is interesting to point out that installation costs could be lower if we get rebates. How to apply for rebates for the pumps and dust collector will be done later on.

*Table 16 Summary of ROI*

	<b>Breakeven point</b>	<b>Saves per Month</b>	<b>Saves per year</b>
<b>1<sup>st</sup> Scenario</b>	28 months	\$71	\$856
<b>2<sup>nd</sup> Scenario</b>	11 months	\$174	\$2088

### **3.13. Recommendations**

We recommend the installation of AC drives for reducing the amount of energy consumed. The initial investment will be recovered in 1 or 2 years approximately depending on the working conditions. Applying The AC Drives will also help the company for being more environmentally friendly.

## 4. Lightning System

### 4.1. Summary

Boyko Metal Finishing Co primarily operates in the powder metal coating industry within the Fabricated Metal Products sector, providing powder coating, metal finishing, enamelling, metal spraying and hot dipping services.

The facility is very big and has a lot of open space, with many windows. Since the facility had many windows, it lets in a lot of light, but bulbs are needed to be OSHA compliant and also a source of light is needed when the sun light does not allow a good visual during the work.

Because of that, the facility counts the following number of bulbs (see table 17).

Our goal will be to reduce the energy waste and consequently waste of money redesigning the main illumination features of the building (warehouse and factory). As a light designer we should:

1. Provide the visibility required based on the task to be performed and the economic objectives.
2. Furnish high quality lighting by providing a uniform illuminance level, where required, and by minimizing the negative effects of direct and reflected glare.
3. Choose luminaires aesthetically complimentary to the installation with mechanical, electrical and maintenance characteristics designed to minimize operational expense.
4. Choose sustainable products that minimize energy usage while achieving the visibility, quality and aesthetic objectives.

Furthermore, there are two solutions to the lighting problems mainly:

1. To select luminaires which are designed to control the light in an effective and energy efficient manner.
2. To apply them to the project with all the skill and ingenuity the designer can bring to bear from his or her own.

Table 17 Summary of the Facility

LOCATION	N° BULBS	TYPE OF BULBS	VOLTAGE	POWER
<b>Warehouse</b>				
	5	Incandescent	227 V	400 W
	8	4' CFL	227 V	400 equi.
	8	4' LED	120 V	400 equi.
<b>Factory</b>				
	10	Incandescent	227 V	400 W
	10	4' CFL	227 V	400 equi.
	8	4' CFL	120 V	400 equi.
	8	8' CFL	120 V	400 equi.
	24	4' LED	120 V	400 equi.
<b>Garage</b>				
	6	8' CFL	120 V	400 equi.
	6	4' CFL	120 V	400 equi.
<b>Office</b>				
	2	Incandescent	120 V	
	18	4' CFL	120 V	
	10	8' CFL	120 V	
<b>Door</b>				
	2	2' CFL	120 V	
<b>Door outside</b>				
	1	Incandescent	240 V	
<b>Hall</b>				
	2	4' CFL	120 V	



## 4.2. Introduction

The idea in order to save energy is to replace the Incandescent bulbs with LED bulbs.

An incandescent light bulb, incandescent lamp or incandescent light globe is an electric light which produces light with a wire filament heated to a high temperature by an electric current passing through it, until it glows (see Incandescence). The hot filament is protected from oxidation with a glass or quartz bulb that is filled with inert gas or evacuated. In a halogen lamp, filament evaporation is prevented by a chemical process that redeposits metal vapor onto the filament, extending its life. The light bulb is supplied with electric current by feed-through terminals or wires embedded in the glass. Most bulbs are used in a socket which provides mechanical support and electrical connections. Incandescent bulbs are manufactured in a wide range of sizes, light output, and voltage ratings, from 1.5 volts to about 300 volts. They require no external regulating equipment, have low manufacturing costs, and work equally well on either alternating current or direct current. As a result, the incandescent lamp is widely used in household and commercial lighting, for portable lighting such as table lamps, car headlamps, and flashlights, and for decorative and advertising lighting.

Light-emitting diodes, or LEDs, were for years most commonly found in small electronic displays, such as the clock on your cable box. Because the light emitted by each tiny LED is directional and fairly weak, household LED bulbs were on the fringe of mainstream technology just a few years ago. According to the Lighting Research Center, LED light bulbs work by bringing together currents with a positive and negative charge to create energy released in the form of light. The result is a fast source of light that is reliable, instantaneous, and able to be dimmed. What sets LEDs apart from incandescent bulbs and CFLs is just how long they can last. According to Consumer Reports, LED light bulbs can last anywhere from 20,000 to 50,000 hours, or up to five times longer than any comparable bulb on the market. But that combination of efficiency and durability has historically come at a cost. LEDs cost more money than CFLs and incandescent bulbs. The good news, however, is that their price has dropped considerably over the years.

According to EnergyStar.gov, CFLs work differently than incandescent bulbs in that, instead of running an electric current through a wire filament, they drive an electric current through a tube that contains argon and mercury vapor. This process creates ultraviolet light that quickly translates into visible light, unlike incandescent lights which put off a warm glow. The big difference between CFLs and incandescent bulbs is how much energy it takes to use them over time. CFLs use about 70% less energy than incandescent bulbs. They also last years longer than traditional bulbs, and only cost about a dollar more per bulb. However, one of the biggest drawbacks of CFLs is that it takes a few moments for them to warm up and reach full brightness. That means they're not ideal in spots where you want lots of light as soon as you flip the switch, such as a dark, steep basement stairway. They also cannot be used with a dimmer switch. Plus, modern CFLs contain a small amount of mercury, which is very harmful to both your health and the environment. That means it's bad news to break one (here's how to clean it up safely if you do), and they shouldn't be disposed of in your regular household trash (here's how to recycle them).

The following table resume the main differences between these three types of bulb.

*Table 18 Differences between types of bulbs*

<b>General Observations (50000 hrs)</b>	<b>LED</b>	<b>CFL</b>	<b>Incadescent</b>
Light bulb projected lifespan (hrs)	50000	10000	1200
Watts per bulb (equivalent 60W)	10	14	60
Cost per bulb	\$35,95	\$3,95	\$1,25
Kwh of electricity used over 50,000 hrs	500	700	3000
Bulbs needed for 50k hours of use	1	5	42

Look at the Appendix 1 for further information about the three different types of bulbs.

### 4.3. OSHA Regulations

Light is captured by the human eye and processed into an image by the brain. It is a fairly complicated process with the light rays passing through the pupil, an opening in the eye, and through the cornea and lens, which focus the light rays on the retina at the back of the eyeball. The retina is composed of photosensitive receptors, the rods, which are sensitive to black and white, especially at night, but have poor visual acuity, and the cones, which are sensitive to colors in daylight and have good visual acuity. The cones are concentrated in the fovea, while the rods are spread out over the retina. Electrical signals from the photoreceptors are collected and passed by the optic nerve to the brain where the light from external illumination is processed and interpreted. The basic theory of illumination applies to a point source of light (such as a candle) of a given luminous intensity, measured in candelas (cd).

*Image 21 Eye structure*

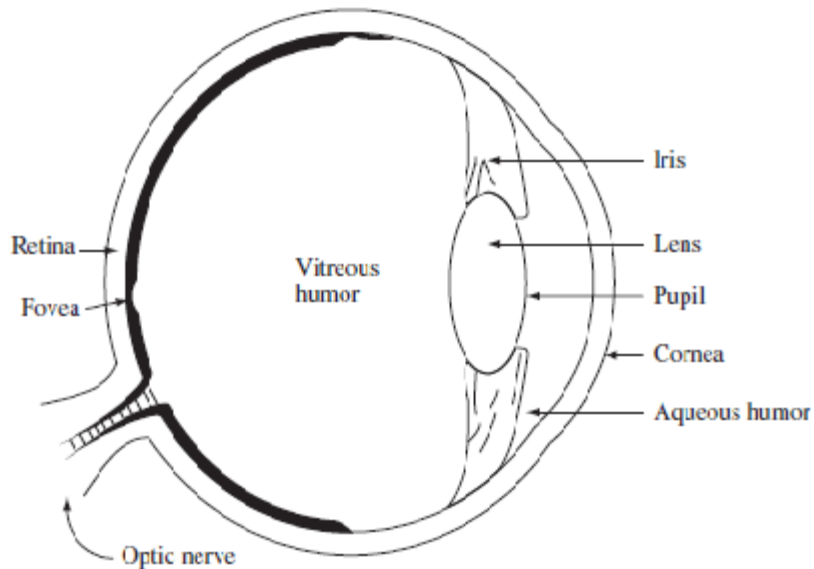

The clarity with which the human sees something is usually referred to as visibility. The three critical factors of visibility are visual angle, contrast, and most important, illuminance. Visual angle is the angle subtended at the eye by the target, and contrast is the difference in luminance between a visual target and its background. The relationship between these three critical factors was quantified by Blackwell (1959) in a series of experiments that led to the development of the Illuminating Engineering Society of

North America (IESNA, 1995) standards for illumination. Although the Blackwell curves (see Figure 6.3) as such are not often used today, they show the trade-off between the size of the object, the amount of illumination (in this case, measured as luminance reflected from the target), and the contrast between the target and background. Thus, although increasing the amount of illumination is the simplest approach to improving task visibility, it can also be improved by increasing the contrast or increasing the size of the target.

In order to be OSHA complaint we have to calculate the right luminance taking into account 3 factors:

- Average age of the workers
- Reflectance of the site work
- Speed and accuracy

*Table 19 Table of Weights*

Task and worker characteristics	Weight		
	-1	0	+1
Age	<40	40-55	>55
Reflectance of task/surface background	>70%	30-70%	<30%
Speed and accuracy (only for categories D – I)	Not important	Important	Critical

(Adapted from IESNA, 1995)

The first step is to identify the general type of activity to be performed and classify it into one of nine categories, shown in table below. A more extensive list of specific tasks for this process can be found in IESNA (1995). Note that categories A, B, and C do not involve specific visual tasks. For each category, there is a range of illuminances (low, middle, high).

Table 20 Classification of Illuminance

Category	Range of illuminance (fc)	Type of activity	Reference area
A	2-3-5	Public areas with dark surroundings.	General lighting throughout room or area.
B	5-7.5-10	Simple orientation for short temporary visits.	
C	10-15-20	Working spaces where visual tasks are performed only occasionally.	
D	20-30-50	Performance of visual tasks of high contrast or large size, e.g., reading printed material, typed originals, handwriting in ink and xerography; rough bench and machine work; ordinary inspection; rough assembly.	Illuminance on task.
E	50-75-100	Performance of visual tasks of medium contrast or small size, e.g., reading medium-pencil handwriting, poorly printed or reproduced material; medium bench and machine work; difficult inspection; medium assembly.	
F	100-150-200	Performance of visual tasks of low contrast or very small size, e.g., reading handwriting in hard pencil on poor-quality paper and very poorly reproduced material; highly difficult inspection, difficult assembly.	
G	200-300-500	Performance of visual tasks of low contrast and very small size over a prolonged period, e.g., fine assembly; very difficult inspection; fine bench and machine work; extra fine assembly.	Illuminance on task via a combination of general and supplementary local lighting.
H	500-750-1,000	Performance of very prolonged and exacting visual tasks, e.g., the most difficult inspection; extra fine bench and machine work; extra fine assembly.	
I	1,000-1,500-2,000	Performance of very special visual tasks of extremely low contrast and small size, e.g., surgical procedures.	

Source: Adapted from IESNA, 1995.

The appropriate value is selected by calculating a weighting factor (-1, 0, +1) based on three task and worker characteristics, shown in table above. These weights are then summed to obtain the total weighing factor. Note that since categories A, B, and C do not involve visual tasks, the speed/accuracy characteristic is not utilized for these categories, and overall room surfaces are utilized in place of task background. If the total sum of the two or three weighting factors is -2 or -3, the low value of the three illuminances is used; if -1, 0, or +1, the middle value is used; and if +2 or +3, the high value is used.

In our Case the facility presents the background mainly of Medium Grey that means a reflectance of 55%, also we fall into category C (Working spaces where visual task is performed only occasionally) for the warehouse, and Category E (Performance of visual task of medium contrast or small size) for the factory, because of that we obtain the following results.

Table 21 Reflectance



Color or finish	Percent of reflected light	Color or finish	Percent of reflected light
White	85	Medium blue	35
Light cream	75	Dark gray	30
Light gray	75	Dark red	13
Light yellow	75	Dark brown	10
Light buff	70	Dark blue	8
Light green	65	Dark green	7
Light blue	55	Maple	42
Medium yellow	65	Satinwood	34
Medium buff	63	Walnut	16
Medium gray	55	Mahogany	12
Medium green	52		

Table 22 Facility weights

	Age	Reflectance	Speed & Accuracy	Weight	Luminance
Category D	<40	> 70%	Important	-1	30 fc
Category D	<40	> 70%	Important	-1	30 fc

We can also conduct this analysis using the software by McGraw-Hill Design Tool

Image 22 Warehouse

Environmental Design - Illumination

Enter the current illuminance level (fc) (enter 0 if unknown)

Select Type of Activity

Category

Description Performance of visual tasks of high contrast or large size, e.g., reading printed material, typed originals, handwriting in ink and xerography; rough bench and machine work; ordinary inspection; rough assembly (Illuminance on task).

Select Task and Worker Characteristics

Age

Reflectance of task/surface background

Speed and Accuracy (only for categories D-I)

Recommended Illumination Level is 30 fc

Image 23 Factory

Environmental Design - Illumination

Enter the current illuminance level (fc) (enter 0 if unknown)

Select Type of Activity

Category

Description Performance of visual tasks of high contrast or large size, e.g., reading printed material, typed originals, handwriting in ink and xerography; rough bench and machine work; ordinary inspection; rough assembly (Illuminance on task).

Select Task and Worker Characteristics

Age

Reflectance of task/surface background

Speed and Accuracy (only for categories D-I)

Recommended Illumination Level is 30 fc

For both rooms, the recommended illumination is 30 fc (foot-candles). However, the illumination should always be higher than 10 fc in the factory.

The bulbs have to be right positioned in order to avoid *glare*. Glare is the excessive brightness in the field of vision. This excessive light is scattered in the cornea, lens, and even corrective lenses (Freivalds, Harpster, and Heckman, 1983), decreasing visibility so that additional time is required for the eyes to adapt from light to darker conditions. Also, unfortunately, the eyes tend to be drawn directly to the brightest light source, which is known as phototropism. Glare can be either direct, as caused by light sources directly in the field of view, or indirect, as reflected from a surface in the field of view. Direct glare can be reduced by using more luminaires with lower intensities, using baffles or diffusers on luminaires, placing the work surface perpendicular to the light source, and increasing overall background lighting so as to decrease the contrast. Reflected glare can be reduced by using nonglossy or matte surfaces and reorienting the work surface or task, in addition to the modifications recommended for direct glare. Also, polarizing filters can be used at the light source as part of glasses worn by the operator. A special problem is the stroboscopic effect caused by the reflections from moving parts or machinery. Avoiding polished mirror like surfaces is important here. For example, the mirror like qualities of the glass screen on computer monitors is a problem in office areas. Repositioning the monitor or using a screen filter is helpful. Typically, most jobs will require supplementary task lighting. This can be provided in a variety of forms, depending on the nature of the task.



## 4.4. Fundamentals of Lighting and Illumination:

Before we go through the implementation of the solutions, some fundamentals of lighting and illumination are needed. First of all, we should answer to the question: *what is light?*

Light is electromagnetic radiation within a certain portion of the electromagnetic spectrum. The word usually refers to visible light, which is visible to the human eye and is responsible for the sense of sight. Visible light is usually defined as having wavelengths in the range of 400–700 nanometres (nm), or  $4.00 \times 10^{-11}$  to  $7.00 \times 10^{-11}$  m, between the infrared (with longer wavelengths) and the ultraviolet (with shorter wavelengths). This wavelength means a frequency range of roughly 430–750 terahertz (THz).

The main source of light on Earth is the Sun. Sunlight provides the energy that green plants use to create sugars mostly in the form of starches, which release energy into the living things that digest them. This process of photosynthesis provides virtually all the energy used by living things. Historically, another important source of light for humans has been fire, from ancient campfires to modern kerosene lamps. With the development of electric lights and power systems, electric lighting has effectively replaced firelight. Some species of animals generate their own light, a process called bioluminescence. For example, fireflies use light to locate mates, and vampire squids use it to hide themselves from prey.

The primary properties of visible light are intensity, propagation direction, frequency or wavelength spectrum, and polarisation, while its speed in a vacuum, 299 792 458 meters per second, is one of the fundamental constants of nature. Visible light, as with all types of electromagnetic radiation (EMR), is experimentally found to always move at this speed in a vacuum.

### Luminous flux

Luminous flux is the time rate of flow of light as measured in lumens. It is a measure of the total light emitted by a source and is most commonly used for measurement of total lamp output.

## Luminous intensity

The candela is the unit of intensity (I) and is analogous to pressure in a hydraulic system. It is sometimes called “candlepower” and describes the amount of light (lumens) in a unit of solid angle. This unit of solid angle is called the steradian. It will be seen from the figure 24 that as the light travels away from the source the solid angle covers a larger and larger area; but the angle itself remains the same, as does the amount of light it contains. Intensity therefore, in a given direction is constant regardless of distance.

*Image 24 Relation between Distance and luminance*

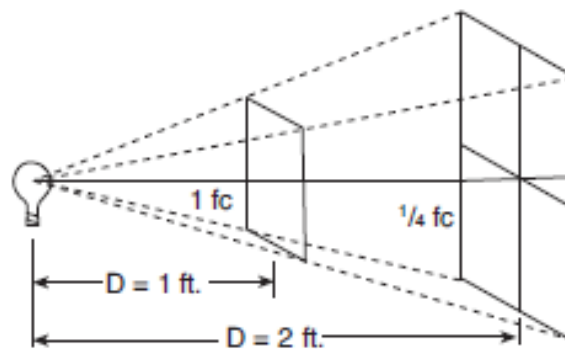

$$I = \frac{(\text{lumens})}{(\text{steradians})}$$

## Illuminance (E)

Illuminance is the quantity of light reaching a unit area of surface and is measured in footcandles or lux. As the area covered by a given solid angle becomes larger with distance from the source, the included light flux remains the same. The illumination density of light on the surface decreases, therefore, with the square of the distance. Illuminance is defined by the intensity ( $\hat{I}$ ) in candelas directed toward point P, divided by the square of the distance (D) from the source to the surface.

$$E = \frac{I}{D^2}$$

This formula holds only if the receiving surface is perpendicular to the source direction. If light is incident at some other angle, see the figure below, the formula becomes

*Image 25 Illustration of the light incident with an angle*

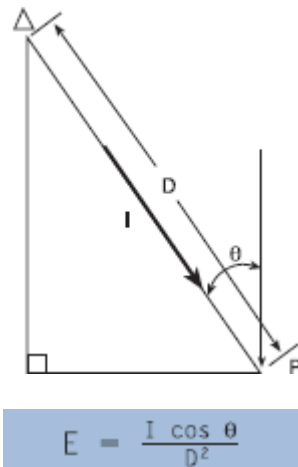

$$E = \frac{I \cos \theta}{D^2}$$

where

E = illuminance in footcandles (fc) or lux

I = intensity in candelas (cd) toward point P

D = distance in feet or meters

$\theta$  = angle of incidence

## **Luminance (L)**

Luminance, defined as intensity in a given direction divided by a surface's projected area as seen by the observer. "Brightness" is a subjective sensation of luminance varying from very dim to very bright. Objectively it is referred to as luminance, The surface may be a luminaire surface or a reflecting surface, such as a wall or roadway. The direct luminance of luminaires at various angles of view is a major factor in the visual comfort evaluation of an installation using those luminaires. In general, it is desirable to minimize the brightness of ceiling mounted luminaires at the high vertical angles, 60°-90°. When the intensity is in candelas, and the projected area is in meters, the unit of luminance is candelas per square meter (cd/m<sup>2</sup>).

These basic knowledges are important to understand what is coming now: the tools we use to determine the right luminance, luminous intensity and illuminance for different bulbs and which of them are the most appropriate for the environment we are looking for.

## Color Rendering Index (CRI)

It is a quantitative measure of the ability of a light source to reveal the colors of various objects faithfully in comparison with an ideal or natural light source. Light sources with a high CRI are desirable in color-critical applications such as neonatal care, photography and cinematography. It is defined by the International Commission on Illumination (CIE) as follows:

*Color rendering: Effect of an illuminant on the color appearance of objects by conscious or subconscious comparison with their color appearance under a reference illuminant*

The CRI of a light source does not indicate the apparent color of the light source; that information is under the rubric of the correlated color temperature (CCT). In the pictures at right it can be noticed that the spectra have different structures; the incandescent lamp has a continuous spectrum, whereas the fluorescent lamp has separate lines in the spectrum due to emission of photons of discrete wavelengths by mercury.

The value often quoted as 'CRI' on commercially available lighting products is properly called the CIE Ra value, 'CRI' being a general term and CIE Ra being the international standard colour rendering index. Numerically, the highest possible CIE Ra value is 100, and would only be given to a source identical to standardized daylight or a Black body (incandescent lamps are effectively blackbodies), dropping to negative values for some light sources. Low-pressure sodium lighting has negative CRI; fluorescent lights range from about 50 for the basic types, up to about 90 for the best tri-phosphor type. Typical LEDs have about 80+ CRI, while some manufacturers claim that their LEDs have achieved up to 98 CRI

The CRI is calculated by comparing the color rendering of the test source to that of a "perfect" source which is a black body radiator for sources with correlated color temperatures under 5000 K, and a phase of daylight otherwise. Chromatic adaptation should be performed so that like quantities are compared. The Test Method (also called Test Sample Method or Test Color Method) needs only colorimetric, rather than spectrophotometric, information.

## Lighting Power Density (LPD)

It is a lighting power requirement defined in North America by the American National Standards Institute (ANSI), American Society of Heating, Refrigerating and Air-Conditioning Engineers (ASHRAE), and the Illuminating Engineering Society of North America (IESNA) Lighting subcommittee.

Lighting Power Density technically represents the load of any lighting equipment in any defined area, or the watts per square foot of the lighting equipment. However, in the lighting industry it is often associated with the lighting power allowance (LPA) permitted by the building energy code in question.

The Oregon Department of Energy defines lighting power density as "The maximum allowable lighting density permitted by the code. It is expressed in watts per square foot for a given occupancy/space type."

Mainly three methods are used to determine the LPD:

- Space By Space Method
- Whole Building Area Method
- Exceptions and Additional Allowances

## Lumen Maintenance LM (LED lightings)

In LED lighting, lumen maintenance is the luminous flux output remaining (expressed as a percentage of the initial output) at any selected elapsed operating time. Lumen maintenance is the converse of lumen method lumen depreciation.

Lumen maintenance compares the amount of light produced from a light source or from a luminaire when it is brand new to the amount of light output at a specific time in the future. For instance, if a luminaire produced 1,000 lumens of light when it was brand new and now produces 700 lumens of light after 30,000 hours, then it would have lumen maintenance of 70% at 30,000 hours. Useful lifetime estimates for LED lighting products are typically given in terms of the expected operating hours until light output has diminished to 70% of initial levels (denoted L70 life).

There are a number of methods for controlling lumen maintenance areas:

- Installing photoreceptors tied directly to ballasts, controlling the voltage output to the lamps based on the set level of luminance.
- Connecting dimming ballasts directly to an energy management system that has been programmed for the expected depreciation of the lamps; the energy management system directs the output of ballasts as necessary to maintain required lighting levels over time.
- Manually verifying lighting levels in a space by using photometers in specific locations, and then manually setting the system to meet lighting requirements.

## Color Temperature

The color temperature of a light source is the temperature of an ideal black-body radiator that radiates light of comparable hue to that of the light source. Color temperature is a characteristic of visible light that has important applications in lighting, photography, videography, publishing, manufacturing, astrophysics, horticulture, and other fields. In practice, color temperature is only meaningful for light sources that do in fact correspond somewhat closely to the radiation of some black body, i.e., those on a line from reddish/orange via yellow and more or less white to blueish white; it does not make sense to speak of the color temperature of, e.g., a green or a purple light. Color temperature is conventionally stated in the unit of absolute temperature, the Kelvin, having the unit symbol K.

Color temperatures over 5,000K are called cool colors (bluish white), while lower color temperatures (2,700–3,000 K) are called warm colors (yellowish white through red). This relation, however, is a psychological one in contrast to the physical relation implied by Wien's displacement law, according to which the spectral peak is shifted towards shorter wavelengths (resulting in a more blueish white) for higher temperatures.

For lighting building interiors, it is often important to take into account the color temperature of illumination. For example, a warmer (i.e., lower color temperature) light is often used in public areas to promote relaxation, while a cooler (higher color temperature) light is used to enhance concentration in offices.

CCT dimming for LED technology is regarded as a difficult task, since binning, age and temperature drift effects of LEDs change the actual color value output. Here feedback loop systems are used for example with color sensors, to actively monitor and control the color output of multiple color mixing LEDs.



Image 26 An example of Color Temperature Profile

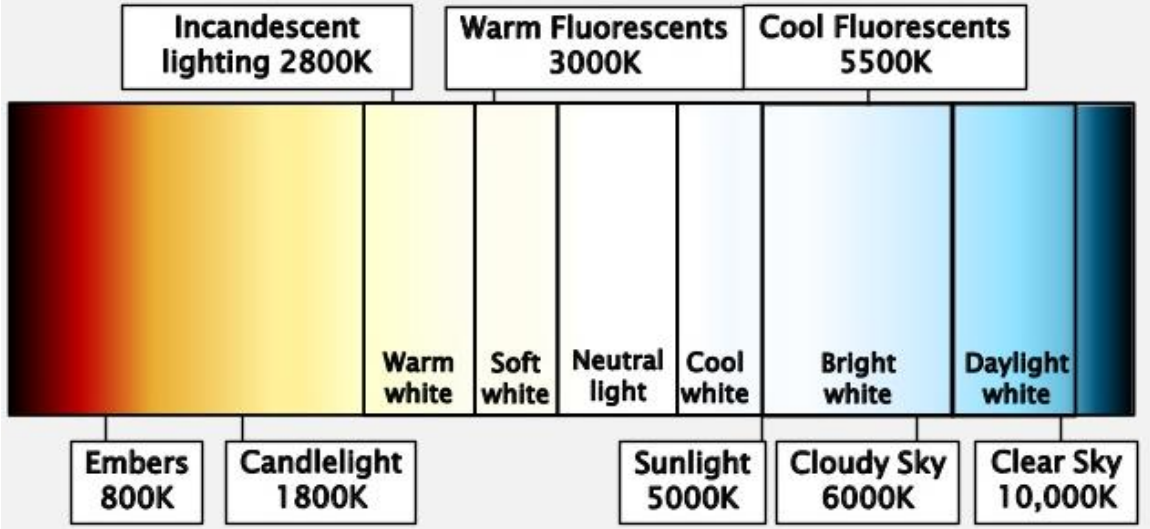

Last but not less important the Photometry, this tool allow to compare different bulbs solutions, comparing their main features

## Photometry

“Photometry” means “the measurement of light.” The term “Photometry” is often used to define any test data which describes the characteristics of a luminaire’s light output. the most common type of photometric data includes candlepower distribution curves, spacing criteria, luminaire efficiency, isofootcandle plots, coefficients of utilization and luminance data. Photometric data is placed into standard format (IESNA file) for use in lighting calculation computer programs

The purpose of a photometric report is to accurately describe the performance of a luminaire, to enable the designer to select the lighting equipment and design a fixture layout which best meets the needs of the job.

Following is a review of the more frequently used types of photometric data.

- *Candlepower distribution curve*

The photometric distribution curve is one of the lighting designer’s most valuable tools. It is a cross-sectional “map” of intensity (candelas) measured at many different vertical angles. It is a two-dimensional representation and therefore shows data for one plane only. If the distribution of the unit is symmetric, the curve in one plane is sufficient for all calculations. If asymmetric, such as with street lighting and fluorescent units, three or more planes are required. In general, incandescent and HID reflector units are described by a single vertical plane of photometry. Fluorescent luminaires require a minimum of one plane along the lamp axis, one across the lamp axis and one at a 45° angle. The greater the departure from symmetry, the more planes needed for accurate calculations.

Image 27 An example of candlepower distribution curve

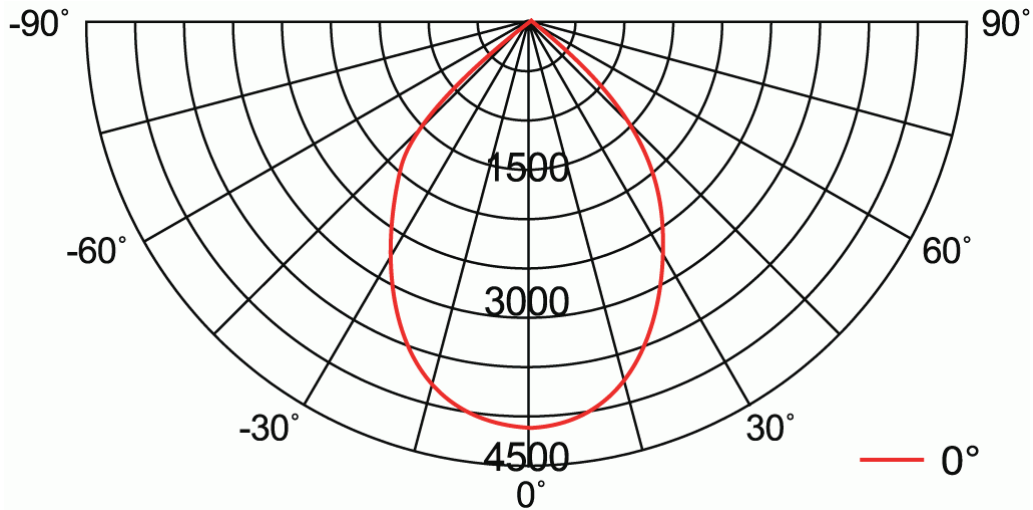

- *Coefficient of utilization (CU)*

A coefficient of utilization refers to the ratio of lumens which ultimately reach the work plane to the total lumens generated by the lamp. CU values are necessary for hand calculating average illuminance levels and are provided in one of two ways: a CU table or a CU curve. A CU curve is usually provided for units intended for outdoor use or units with a distribution radically asymmetric. A CU table is provided for units which are used primarily indoors.

- *Isofootcandle Plot*

Isofootcandle plots are used to describe the light pattern produced by a luminaire, generally for outdoor luminaires. These plots are derived from the candlepower data and show exact plots or lines of equal footcandle levels on the work plane when the fixture is at a designated mounting height.

Image 28 Isofootcandle curves

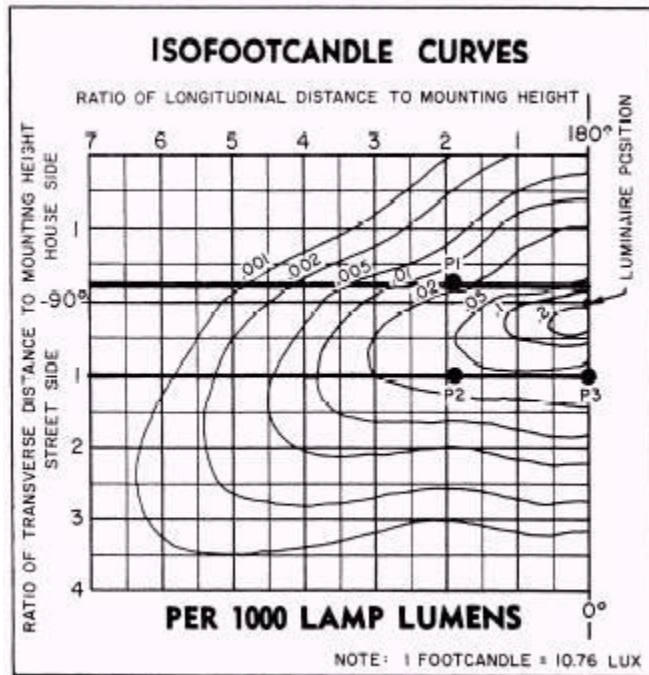

- *Spacing criteria*

Spacing criteria provide the designer with information regarding how far apart luminaires may be spaced while maintaining acceptable illumination uniformity on the work plane. Criteria for spacing are generally conservative; they take into account the direct component of illumination only and ignore the indirect component of light, which can contribute significantly to the uniformity. However, used within its limits, a Spacing Criterion can be valuable. To use the Spacing Criterion, multiply the net mounting height (luminaire to work plane) by the Spacing Criterion number.

## 4.5. Light sources

The lighting industry makes millions of electric light sources, called lamps (or bulbs). Those used for providing illumination can be divided into three general classes: incandescent, discharge, and solid-state lamps. Incandescent lamps produce light by heating a filament until it glows. Discharge lamps produce light by ionizing a gas through electric discharge inside the lamp. Solid-state lamps use a phenomenon called electroluminescence to convert electrical energy to light.

In addition to manufactured light sources, daylight-sunlight received on the Earth either directly from the sun, scattered and reflected by atmosphere, or reflected by the moon- provides illumination. The prime characteristic of daylight is its variability. Daylight varies in magnitude, spectral content, and distribution with different meteorological conditions, at different times of the day and year, and at different latitudes. The illuminances on the Earth's surface produced by daylight can cover a large range, from 150,000 lx on a sunny summer's day to 1000 lx on a heavily overcast day in winter. The spectral composition of daylight also varies with the nature of the atmosphere and the path length through it.

We have already spoken about the bulbs we deal on this chapter, but now we are going to give a more detailed description.

### **Incandescent Lamps**

Incandescent lamp technology uses electric current to heat a coiled tungsten filament to incandescence. The glass envelope contains a mixture of nitrogen and small amount of other inert gasses such as argon. Some incandescent lamps, such as some flashlight lamps, also contain xenon.

Incandescent lamps have come a long way since Thomas Edison's first carbon filament lamp, which, when introduced in 1879, had a life of about 40hours. Today, commonly available incandescent lamps have average life of between 750 and 2000 hours.

The figure below shows the construction of a typical incandescent lamp.

Image 29 Bulb elements

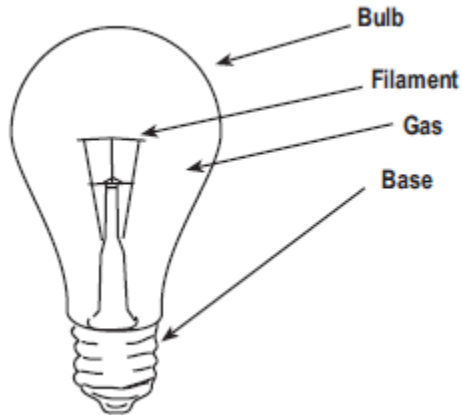

Incandescent lamps are strongly affected by input voltage. For example, reducing input voltage from from the normal 110V to 104,5V (95%) can double the life of a standard incandescent lamp, while increasing voltage to just 115,5V (105% of the normal) can halve its life. Voltage variations also affect light output (lumens), power (watts), and efficacy (lumens per watt), as shown below.

Figure 11 Voltage variations and its effects on light output, power and efficacy

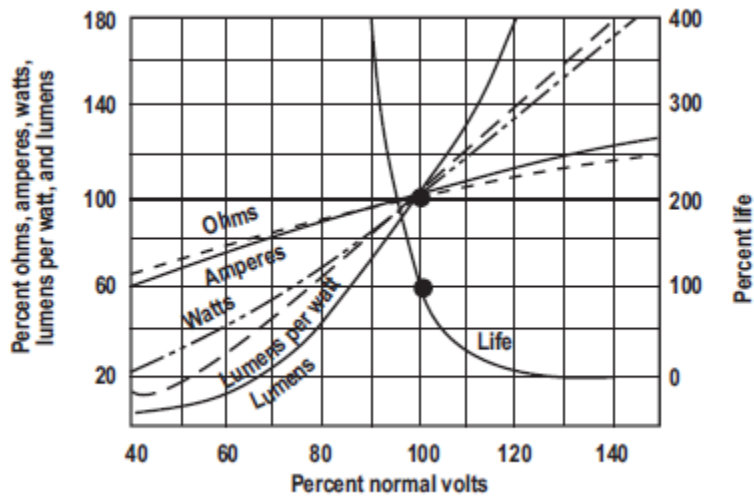

## Fluorescent Lamps

Fluorescent lighting accounts for two-thirds of all electric light in the United States. The fluorescent lamp is a gas discharge source that contains mercury vapor at low pressure, with a small amount of inert gas for starting. Once an arc is established, the mercury vapor emits ultraviolet radiation. Fluorescent powders (phosphors) coating the inner walls of the glass bulb respond to this ultraviolet radiation by emitting wavelengths in the visible region of the spectrum.

Ballasts, which are required by fluorescent lamps, provide the necessary circuit conditions (voltage, current, and waveform) to start and operate the lamps. Two general types of ballast are often more expensive, but are usually lighter, quieter and eliminate the lamp flicker associated with magnetic ballasts.

Fluorescent lamps are often described in terms of the diameter of the lamp tube. For this designation, the diameter is given in eighths of an inch. For example, a T8 lamp has a diameter of one inch (eight eighths), while a T5 lamp has a diameter of  $5/8$  inch.

- Linear Fluorescent Lamp: range in length from six inches to eight feet, and in diameter from  $2/8$  inch (T2) to  $2-1/8$  inches (T17). Their power ranges from 14 to 215 watts. The figure below shows the construction of a linear fluorescent lamp.

*Image 30 Construction of a linear fluorescent lamp*

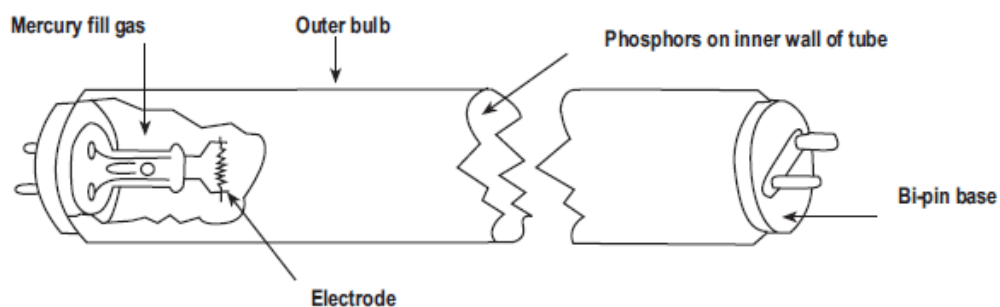

— *Compact Fluorescent Lamps (CFLs)*: CFLs produce light in the same manner as linear fluorescent lamps. Their tube diameter is usually 5/8 inch (T5) or smaller. CFL power ranges from 5 to 55 watts. Some examples of CFLs.

*Image 31 Types of CFLs*

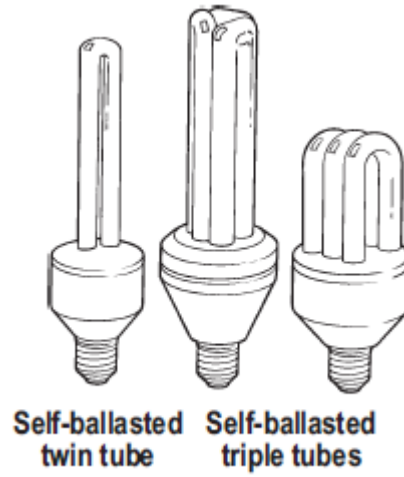



**LEDs (Light-Emitting Diodes)**

LEDs are solid-state semiconductor devices that convert electrical energy directly into light. LEDs can be extremely small and durable; some LEDs can provide much longer lamp life than other sources.

The figure below shows several typical LEDs. The plastic encapsulant and the lead frame occupy most of the volume. The light-generating inside the chip, a solid crystal material, when current flows across the junction of different materials. The composition of the materials determines the wavelength and therefore the color of light.

*Image 32 Types of Diodes*

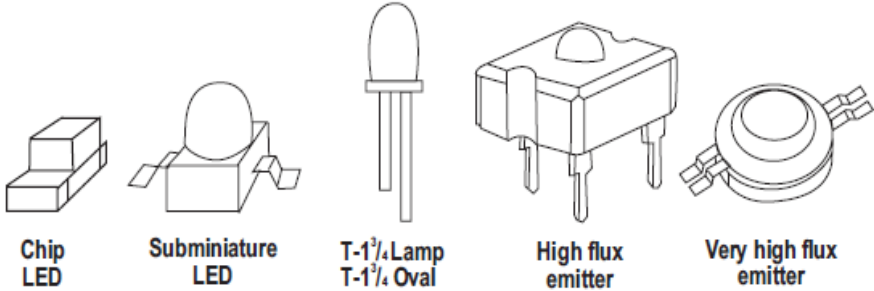

LEDs can generate red, yellow green, blue or white light, have a life up to 100,000 hours, and are widely used in traffic signals and for decorative purposes. White light LEDs are a recent advance and may have a great potential market for some general lighting application.

## 4.6. Solutions Implementation

It is now time to implement any possible solution to achieve the goal explained in the summary of this chapter. The company requires bulbs with the following specifications:

- Color Rendering Index (CRI) higher than 85
- Lighting Power Density (LPD) LOWER THAN 1.0
- The LED must be LM80 tested
- Average life 50,000 hours
- Color Temperature of 4000K

The company also provided the name of two manufactures: *Mercury Lighting Products Co. Inc.* and *National Lighting*. Both manufactures are from New Jersey and are Boyko's costumers.

The solution implementation will go through 3 main steps:

- Select an adequate bulb according the specifications;
- Define an excel file with the investment analysis for one bulb;
- Use the excel file to calculate the investment for how many bulbs desired.

## Product 1: Mercury Lighting Products Co. Inc.: LHB5-4-24000-40K-U80-UNI.IES

### LHB5 SERIES

#### Industrial High Bay LED Luminaire

*Image 33 Mercury Lighting Product LHB5-4-240000-40K-U80-UNI.IES*

### LHB5 SERIES



- High Bay style linear ambient LED luminaire.
- Designed for the higher ceilings found in industrial locations as well as warehouses, big box retailing and gymnasiums.
- Ultra-thin thermally designed full body style housing.
- Standard nominal lumen packages: 12,000lm and 16,000lm in a 24" length housing, 24,000lm and 32,000lm in a 48" length housing.
- Other lumen packages upon request.
- Digital LED technology provides high efficacy and energy efficiency.
- No maintenance required as High Bay LED luminaries require no re-lamping efforts. Extremely important with intended mounting heights up to 35 feet.
- Lumen maintenance: Reported L70 (hours) & L80 (hours) > 60,000 for Osram and ULT components.
- CRI greater than 80.
- Fixture lumens per watt ratios up to 125.
- Operating ambient temperature up to 104°F.
- For new installations or direct replacement for older HID or fluorescent luminaries.

This type of LED Luminaire match with all the specification we made starting this paragraph, in particular, according to our needed we will choose:

24,000lm in a 48'' length housing at 4000 K and 189W Power

*Image 34 Photometry Product 1*

**IES INDOOR REPORT**  
**PHOTOMETRIC FILENAME : LHB5-4-24000-40K-U80-UNI.IES**  
**POLAR GRAPH**

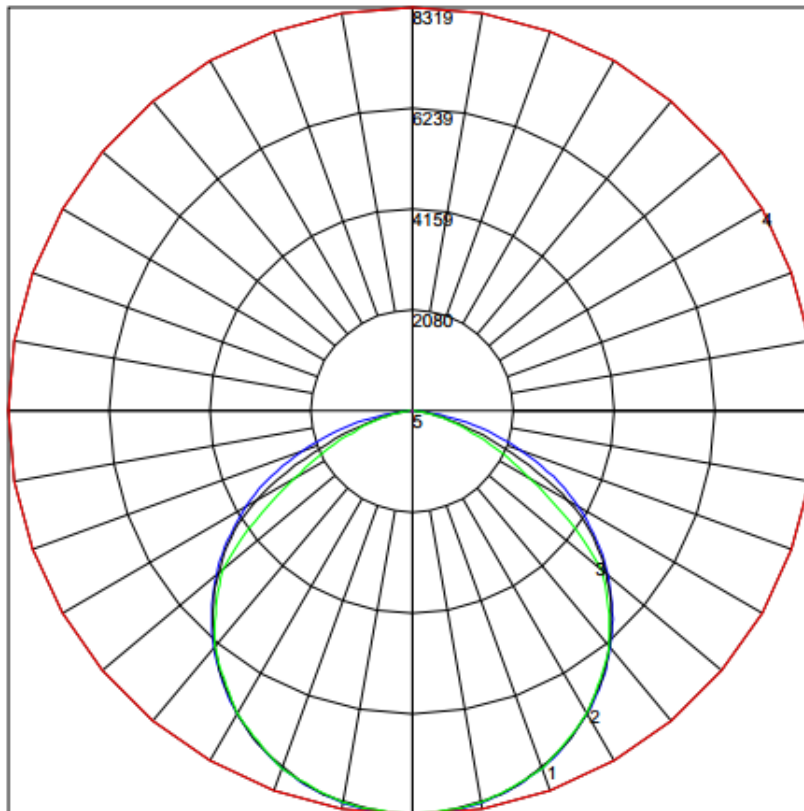

Maximum Candela = 8318.63 Located At Horizontal Angle = 0, Vertical Angle = 0  
# 1 - Vertical Plane Through Horizontal Angles (0 - 180) (Through Max. Cd.)  
# 2 - Vertical Plane Through Horizontal Angles (45 - 225)  
# 3 - Vertical Plane Through Horizontal Angles (90 - 270)  
# 4 - Horizontal Cone Through Vertical Angle (0) (Through Max. Cd.)  
# 5 - Horizontal Cone Through Vertical Angle (90)

Look at the Appendix 2 for further details.

## Product 2. Mercury Lighting Products Co. Inc.: LW4 SERIES Architectural Linear Ambient LED Luminaire

*Image 35 Product 2. LW4 SERIES Architectural Linear Ambient LED Luminaire*



- Shallow form linear ambient LED luminaire.
- Small-scale rounded profile acrylic diffuser evenly surrounds the LED light source enabling a very wide and near-perfect light distribution.
- Compact design complies with all ADA requirements for public areas.
- Custom formulated high diffusion acrylic material allows for maximum light transmission while eliminating pixilation and hot spots.
- Optional integral side reflectors add both function and architectural contour.
- Nominal 2Ft., 4Ft. or 8Ft. long modules.
- Digital LED technology provides high efficacy and energy efficiency.
- Multiple power and light levels are offered as standard to allow meeting design and energy needs per application. Custom factory set levels available on request.
- Lumen maintenance; Reported L70 (hours) & L80 (hours) > 60,000 for Osram and ULT components.
- CRI greater than 80.
- Fixture lumens per watt ratios 85 or higher.
- American Made.

This type of LED Luminaire match with all the specification we made starting this paragraph, in particular, according to our needed we will choose:

5000lm in a 48" length housing and 4000K with 54,7W Power.

Image 36 Photometry Product 2

**Distribution - Goniophotometer**

Distribution Test Conditions

Temperature	Voltage	Current	Power	Power Factor	Frequency	Current THD
24.6 °C	120.0 VAC	0.4337 A	51.95 W	0.998	60 Hz	4.73 %

**Summary of Results**

Spacing Criteria  
 0-180: 1.18  
 90-270: 1.18

Total Lumen Output: 5157 Lumens  
 Luminaire Efficacy: 99.3 lm/w  
 Maximum Candela: 1781 Candela

**Polar Plot**

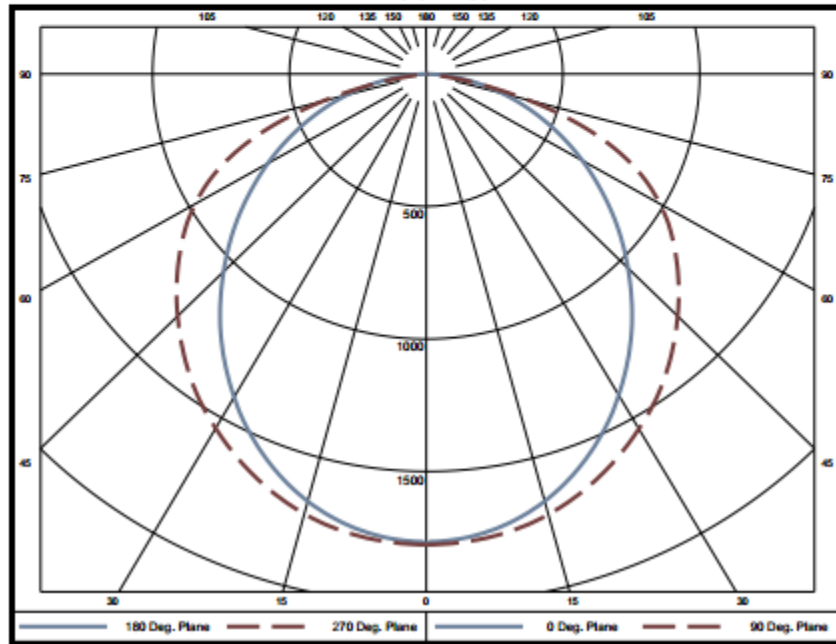

Look at appendix 3 for further details.

Those two solutions are the best ones that answer to the specifications gave by the company, but at the same time both have different power consuming (in terms of Watt) and also different normal lumens. So Investment analysis will give us another situation point of view.

## 4.7. Investment Analysis

Our analysis consists mainly in developing a *Net Present Value (NPV)* and a *Payback Period (PBP)* for each month since the implementation of the new solutions. We assume that the *period 0* (when the new bulbs replace the old ones) is Jan-2016 and we also consider an investment period of 5 years (please take into account that the *PBP* should not go over three years). Before starting let's go through the basic concepts of *NPV* and *PBP*

### Net Present Value (NPV)

The net present value (NPV) (or net present worth (NPW)) is defined as the sum of the present values (PVs) of incoming and outgoing cash flows over a period of time. Incoming and outgoing cash flows can also be described as benefit and cost cash flows, respectively. The Net Present Value is determined by calculating the costs (negative cash flows) and benefits (positive cash flows) for each period of an investment. The period is typically one year, but could be measured in quarter-years, half-years or months a positive NPV results in profit, while a negative NPV results in a loss.

### Payback Period (PBP)

The length of time required to recover the cost of an investment. The payback period of a given investment or project is an important determinant of whether to undertake the position or project, as longer payback periods are typically not desirable for investment positions because it does not take into account the time value of money.

$$\text{PBP} = \text{Initial Investment} / \text{Monthly Inflows}$$

We can now proceed analyzing the situations involved in this project.

Investment Analysis Mercury Lighting Products Co. Inc.: LHB5-4-24000-40K-U80-UNI.IES

Image 37 Investment Analysis LHB5-4-24000-40K-U80-UNI.IES

<b>investment Analysis: From Incandescent Bulbs to LED Bulbs</b>		
<b>General Observations</b>		
	<b>LED</b>	<b>Incadescent</b>
<b>Light bulb projected lifespan (hrs)</b>	50000	1200
<b>Watts per bulb (equivalent 60W)</b>	185	400
<i>Insert the desired value in the yellow spaces. (just use the TAB button)</i> <i>Be carefull: the total amount hours is set for one month usage, on an average of 22 days per month 16 hours a day</i>		
<b>FROM INCANDESCENT TO LED</b>		
<b>One month Usage (Avarage of 22 days per mont working 16 hrs per day)</b>		
	<b>LED</b>	<b>Incadescent</b>
<b>Total amount of hours</b>	352	352
<b>Watts per bulb</b>	185.00	400
<b>Cost per bulb</b>	\$250.00	
<b>kWh of electricity used over using hours</b>	65.12	140.8
<b>Total cost of electricity</b>	\$6.26	\$13.53
<b>Cost Saved</b>	\$7.27	\$0.00
<b>Savings from using Incandescent bulbs (per bulb)</b>	\$66.06	
<b>Number of bulbs</b>	8	
<b>Total Savings (per number of bulbs)</b>	\$528.49	
<b>External Factors</b>		
<b>Installation Costs</b>	\$2,000.00	
<b>Others Initial Costs</b>	\$0.00	
<b>Power Conversion Factor Incandescent to LED</b>	0.463	

From this analysis we derive the following charts that allow us to determine mathematically the Payback Period and the Net Present Value



Figure 12 Payback period product 1

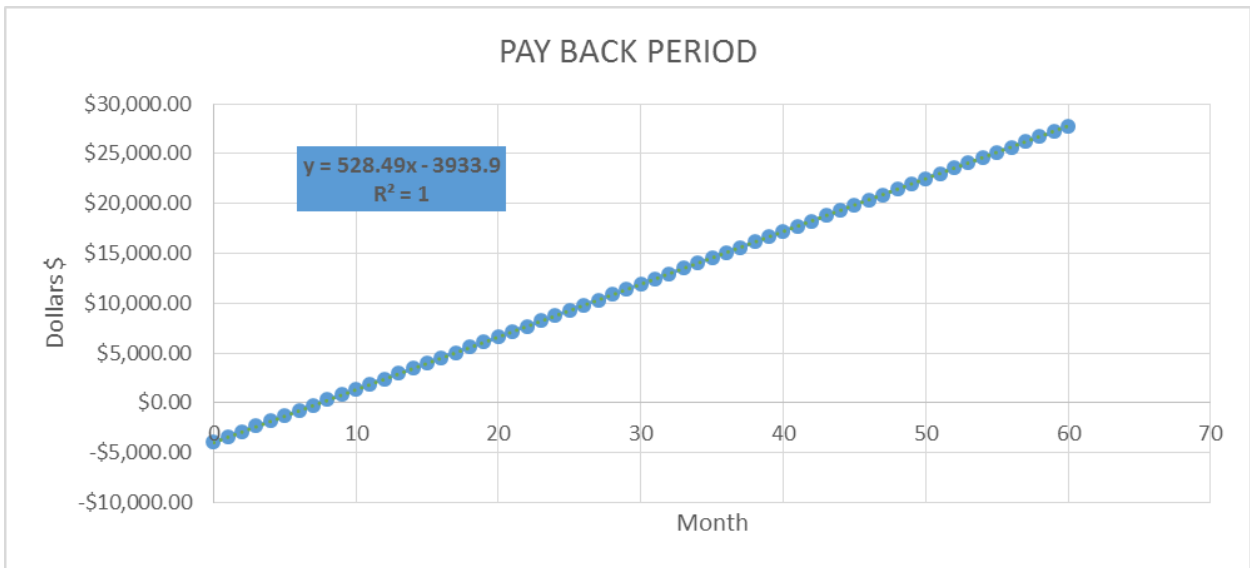

Investment Analysis Mercury Lighting Products Co. Inc.: LW4 SERIES Architectural Linear Ambient LED Luminaire

Image 38 Investment Analysis LW4 SERIES Architectural Linear Ambient LED Luminaire

<b>investment Analysis: From Incandescent Bulbs to LED Bulbs</b>		
<b>General Observations</b>		
	<b>LED</b>	<b>Incandescent</b>
Light bulb projected lifespan (hrs)	50000	1200
Watts per bulb (equivalent 60W)	185	400
<p><i>Insert the desired value in the yellow spaces. (just use the TAB button)</i>  <i>Be careful: the total amount hours is set for one month usage, on an average of 22 days per month 16 hours a day</i></p>		
<b>FROM INCANDESCENT TO LED</b>		
<b>One month Usage (Average of 22 days per month working 16 hrs per day)</b>		
	<b>LED</b>	<b>Incandescent</b>
Total amount of hours	352	352
Watts per bulb	185.00	400
Cost per bulb	\$325.00	
kWh of electricity used over using hours	65.12	140.8
Total cost of electricity	\$6.26	\$13.53
Cost Saved	\$7.27	\$0.00
Savings from using Incandescent bulbs (per bulb)	\$66.06	
Number of bulbs	8	
Total Savings (per number of bulbs)	\$528.49	
<b>External Factors</b>		
Installation Costs	\$2,800.00	
Others Initial Costs	\$0.00	
<b>Power Conversion Factor Incandescent to LED</b>	<b>0.463</b>	

From this analysis we derive the following charts that allow us to determine mathematically the Payback Period and the Net Present Value

Figure 13 Payback period product 2.

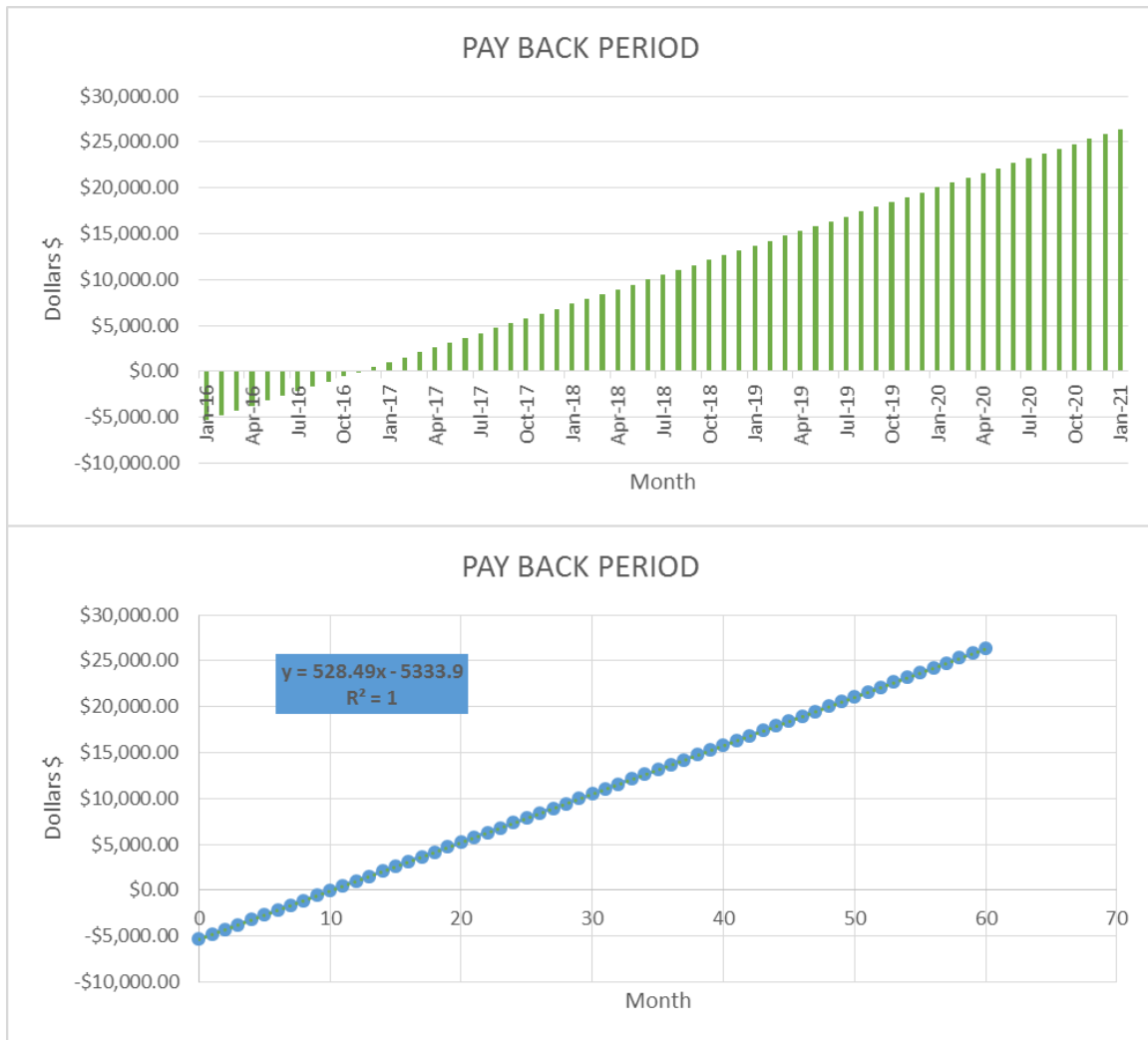

However, we have created an Excel file that allow the company to analyze any situation, just putting the equivalent Incandescent Watt Power, the price on the new bulb the number of bulbs desired and eventually installations and other costs and automatically the file will show the NPV and PBP for this kind of investment. We built it both for switch from Incandescent to LED or Incandescent to CFL. Switch from CFL to LED is not recommended.

## 4.8. Recommendations

We are going now to list the goals we have achieved during the whole project.

1. Described the OSHA regulation and designed, using design tool software, the foot-candles required in the facility according to its characteristics;
2. Went through the fundamentals of lighting, explaining basic concepts required in order to choose the correct illumination system, also because the company asked for determined requirements based on these concepts;
3. Described the main features of the bulbs we are going to deal with: Incandescent, CFL and LED;
4. We find some products from two manufacturers suggested by the company owner, Mr. Boyko. From those solutions we chose the ones that we thought were the most significant and we developed an investment analysis on those 2 products;
5. From the investment analysis we find out the following results:

*Table 23 Investment of product 1*

<b>INVESTMENT 1</b>		
<b>Net Present Value</b>	<b>\$27,775.52</b>	<b>GOOD INVESTMENT</b>
<b>Pay Back Period</b>	<b>7.4</b>	Months

*Table 24 Investment of product 2*

<b>INVESTMENT 2</b>		
<b>Net Present Value</b>	<b>\$26,375.52</b>	<b>GOOD INVESTMENT</b>
<b>Pay Back Period</b>	<b>10.1</b>	Months

Those are the best solutions we came up with, if the company will decide to implement our solutions we expect a reduction on the monthly bills of about 15-20% because of the reduction in the power consumption obtained by moving to LED.

With that we can consider this analysis ended.

## 5. Meters

### 5.1. Scope

Determine the appropriate steps to install a ERT meter (Encoder Receiver Transmitter) or a Smart Meter.

### 5.2. Current Conditions

*Image 39 Itron SENTINEL, multi-measurement Meter*



*Image 40 DRESSER Series B3: 11M175 ROOTS gas meter*



### 5.3. Proposed solution

- ERT (Encoder Receiver Transmitter) meters are digital meters that use a low-power radio signal to transmit readings to hand-held devices carried by meter readers or specially equipped trucks. This automated meter reading (AMR) ability safely improves the accuracy and efficiency of meter readings.
- A smart meter is usually an electronic device that records consumption of electric energy in intervals of an hour or less and communicates that information at least daily back to the utility companies for monitoring and billing. Smart meters enable two-way communication between the meter and the central system. Smart readers can also record the consumption of natural gas and water.

Image 41 ERT Meter



ERT meter allows a meter reader to read the meter wireless as long as the meter and the wireless device is in range (Bluetooth meter reading). ERT meters eliminates the trouble of manually checking meters one by one, as you can record multiple reading as long as the ERT is in range with the wireless reader.

*Image 42 Smart Meter*



Smart meters eliminate the meter reader utility worker completely as it sends and receives signals from the meter to the Utility Company. Smart meters are very sophisticated as it can generate detail energy reports, energy logs and accurate billing due to the meter constant communication. However, many user have reported an increase in their utility bills after installing a smart meter.

- The appropriate steps to installing either an ERT meter or Smart meter are similar in the state of New Jersey. According to PSEG Inspection center, the steps to installing any meter to any infrastructure requires
- A certified electrician comes to the location, audits the existing meters and wiring configuration. The electrician will then have to fill out and submit a wiring application and a Cut-In Card application to City Hall. The application will determine if the meters and the wiring are adequate enough to begin installing the new meter(s) to an existing meter(s) or will the electrician will have to cut and rewire to install a new meter fixture. After the local authorities approve the application, you can begin installation. Once installation is complete, local authorities must inspect the meter and provide PSEG with a certificate of approval (Cut-In Card) before PSEG will allow service to the new meter. Afterward PSEG inspection team will then inspect the meter to ensure that the meter meets with Government safety regulations.
- During installation, you may have to suspend electrical and gas services for approximately 1 hour.



## 6. PSE&G Billing Period

### 6.1. Overview

Boyko Metal Finishing is composed of two meters, one electric Itron SENTINEL multi-measurement Meter and one DRESSER Series B3: 11M175 ROOTS gas meter. Currently, Public Service Enterprise Group (PSEG) is not reading Boyko's meters each month, which consequently creates an estimated billing cycle and not an actual meter read billing cycle. Estimated billing occurs when PSEG is not able to read the meters due to:

- Not being able to access meters: Customer isn't available to grant access to utility worker.
- Human error: Workers omits and meter doesn't get read.
- Weather: Unsafe weather conditions for workers.

During an estimated billing cycle, PSEG will use the last actual meter read billing cycle to determine the electrical and gas cost for the month. PSEG will account for variables such as weather and behavior in your utility load during the previous months. During this past year Boyko recorded that PSEG have read the meter bi-monthly, which cause some variation in billing due to the estimated billing. Boyko is also the beneficiary of having his billing payments fall between the second week of each month, instead of the accustomed end of moth billing or first of the month billing.

### 6.2. Scope

Boyko is looking to resolve the following

1. Change the billing payment date from the 14<sup>th</sup> of each month to the 1<sup>st</sup> of each month, so Boyko's accounts receivable can be on the same date as his accounts payable.
2. Reduce or eliminate the estimated billing cycles.

### **6.3. Current situation**

Meters are read bi-monthly.

### **6.4. Proposed solution**

PSEG stated that you couldn't change the billing payment date due to the contributing factors.

1. Your billing date is determined by the scheduled date after your meter has been read.
2. PSEG meter reading schedule is a fixed schedule determined by location and the worker's path. Since PSEG reads every meter in a radius of "X" miles long, changing one date to read Boyko's meter will disrupt the worker's path. PSEG also stated, "the way they see fit to changing the payment date, is if all the customers in the radius of "X" miles decide to change their meter reading date to the first of each month.

As for changing the billing payment from the 14<sup>th</sup> of each month to the 1<sup>st</sup> of each, we plan to speak with PSEG again to determine if the countermeasure of inputting the meter reading online going forward will make changing the payment due date to the 1<sup>st</sup> of each month acceptable. Since PSEG expressed that the changing of the payment due date is restricted because of the constraints of the scheduled meter reading by a PSEG utility worker path, if we eliminate the constraint, then we can prorate one month's bill so we begin a new payment cycle of the 1<sup>st</sup> of each month. If this solution is obtainable, Boyko will now have his accounts payable in relation to his accounts receivable.

## **6.5. Recommendations**

We recommend that Boyko should in fact update his meters to newer technology. Both meters will supply accurate readings to record, if Boyko decides to initiate submitting the meter readings online. However, the more data Boyko have on utility usage, the more opportunity for energy saving. Therefore, we suggest upgrading to smart meters since smart meters will generate hourly reports of consumption. With the data given from the reports, Boyko will have information that will show Peak hours of usage as well as Off Peak. With the reports, Boyko can begin developing Energy Management Programs, which will help save the metal coating company money.







## 7. References Cited



- <http://www.thesimpledollar.com/the-light-bulb-showdown-leds-vs-cfls-vs-incandescent-bulbs-whats-the-best-deal-now-and-in-the-future/>
- [https://en.wikipedia.org/wiki/Incandescent\\_light\\_bulb](https://en.wikipedia.org/wiki/Incandescent_light_bulb)
- Niebel's Methods, Standards, and Work Design, 12th Edition by Freivalds
- <http://lighting.cree.com/products/outdoor/canopy-and-soffit/cree-edge-series>
- Design Tool software by Mc Graw-Hill Education
- The fundamentals of lighting by Holophane®
- Illumination Fundamentals, Lighting Research Center
- Wikipedia the free encyclopedia
- PSE&G Understanding bill
- <http://www.designrecycleinc.com/led%20comp%20chart.html>
- <http://www.mercltg.com/>
- User Manual ACS310 drive, ABB Group
- ABB General Purpose Catalog ACS310 drive
- Filter Pump Industries Penguin Pumps  
[http://www.filterpump.com/uploads/3/1/7/1/31717119/p\\_201m-b.pdf](http://www.filterpump.com/uploads/3/1/7/1/31717119/p_201m-b.pdf)
- Karassik, I. "Manual de Bombas". Ed. McGraw-Hill. 1982
- Warring, R.H. "Selección de bombas. Sistemas y aplicaciones". Ed. Labor, 1977
- McNaughton, K. "Bombas. Selección, uso y mantenimiento". Ed. McGraw-Hill, 1987



## 8. Appendix

### 8.1. Appendix 1. Comparison Chart

Comparison Chart  
LED Lights vs. Incandescent Light Bulbs vs. CFLs

<p style="text-align: center;"><b>Energy Efficiency &amp; Energy Costs</b></p>	 <p style="text-align: center;"><b>Light Emitting Diodes (LEDs)</b></p>	 <p style="text-align: center;"><b>Incandescent Light Bulbs</b></p>	 <p style="text-align: center;"><b>Compact Fluorescents (CFLs)</b></p>
<p style="text-align: center;"><b>Life Span (average)</b></p> <p style="text-align: center;"><b>Watts of electricity used</b> (equivalent to 60 watt bulb).</p> <p>LEDs use less power (watts) per unit of light generated (lumens). LEDs help reduce greenhouse gas emissions from power plants and lower electric bills</p> <p style="text-align: center;"><b>Kilo-watts of Electricity used</b> (30 Incandescent Bulbs per year equivalent)</p> <p style="text-align: center;"><b>Annual Operating Cost</b> (30 Incandescent Bulbs per year equivalent)</p>	<p style="text-align: center;">50,000 hours</p> <p style="text-align: center;">6 - 8 watts</p> <p style="text-align: center;">329 KWh/yr.</p> <p style="text-align: center;">\$32.85/year</p>	<p style="text-align: center;">1,200 hours</p> <p style="text-align: center;">60 watts</p> <p style="text-align: center;">3285 KWh/yr.</p> <p style="text-align: center;">\$328.59/year</p>	<p style="text-align: center;">8,000 hours</p> <p style="text-align: center;">13-15 watts</p> <p style="text-align: center;">767 KWh/yr.</p> <p style="text-align: center;">\$76.65/year</p>
<p style="text-align: center;"><b>Environmental Impact</b></p> <p style="text-align: center;"><b>Contains the TOXIC Mercury</b></p> <p style="text-align: center;"><b>RoHS Compliant</b></p> <p style="text-align: center;"><b>Carbon Dioxide Emissions</b> (30 bulbs per year)</p> <p>Lower energy consumption decreases: CO2 emissions, sulfur oxide, and high-level nuclear waste.</p>	 <p style="text-align: center;"><b>Light Emitting Diodes (LEDs)</b></p>	 <p style="text-align: center;"><b>Incandescent Light Bulbs</b></p>	 <p style="text-align: center;"><b>Compact Fluorescents (CFLs)</b></p>
	<p style="text-align: center;">No</p> <p style="text-align: center;">Yes</p> <p style="text-align: center;">451 pounds/year</p>	<p style="text-align: center;">No</p> <p style="text-align: center;">Yes</p> <p style="text-align: center;">4500 pounds/year</p>	<p style="text-align: center;">Yes - Mercury is very toxic to your health and the environment</p> <p style="text-align: center;">No - contains 1mg-5mg of Mercury and is a major risk to the environment</p> <p style="text-align: center;">1051 pounds/year</p>

<b><u>Important Facts</u></b>	 <b>Light Emitting Diodes (LEDs)</b>	 <b>Incandescent Light Bulbs</b>	 <b>Compact Fluorescents (CFLs)</b>
Sensitivity to low temperatures	None	Some	Yes - may not work under negative 10 degrees Fahrenheit or over 120 degrees Fahrenheit
Sensitive to humidity	No	Some	Yes
On/off Cycling Switching a CFL on/off quickly, in a closet for instance, may decrease the lifespan of the bulb.	No Effect	Some	Yes - can reduce lifespan drastically
Turns on instantly	Yes	Yes	No - takes time to warm up
Durability	Very Durable - LEDs can handle jarring and bumping	Not Very Durable - glass or filament can break easily	Not Very Durable - glass can break easily
Heat Emitted	3.4 btu's/hour	85 btu's/hour	30 btu's/hour
Failure Modes	Not typical	Some	Yes - may catch on fire, smoke, or omit an odor

<b><u>Light Output</u></b>	 <b>Light Emitting Diodes (LEDs)</b>	 <b>Incandescent Light Bulbs</b>	 <b>Compact Fluorescents (CFLs)</b>
Lumens 450 800 1,100 1,600 2,600	Watts 4-5 6-8 9-13 16-20 25-28	Watts 40 60 75 100 150	Watts 9-13 13-15 18-25 23-30 30-55

## 8.2. Appendix 2: LHB5-4-24000-40K-U80-UNI.IES







### **8.3. Appendix 3: LW4 SERIES Architectural Linear Ambient LED Luminaire**



UNIVERSITAT  
POLITÈCNICA  
DE VALÈNCIA

# GESTION DE INVENTARIO Y SISTEMAS DE CONTROL

Boyko's Metal Finishing CO

*MARIA JOSE DEMA FRESNEDA  
GIULIANO BERENATO  
TIMOTHY ELLIS  
CARLOS MIGUEL MORENO MARIN*



NJIT

New Jersey's Science &  
Technology University

# INVENTORY MANAGEMENT AND CONTROL SYSTEM

Boyko's Metal Finishing CO

*MARIA JOSE DEMA FRESNEDA  
GIULIANO BERENATO  
TIMOTHY ELLIS  
CARLOS MIGUEL MORENO MARIN*



## **Acknowledgment**

The project opportunity we had with Boyko's Metal Finishing Company was a great chance for learning and professional development. Therefore, we consider ourselves as very lucky people as we were provided with an opportunity to be a part of it. We are also grateful for having had a chance to meet so many wonderful people and professionals.

In performing our project, we had to take the help and guideline of some respected persons, who deserve our greatest gratitude. The completion of this assignment gives us much Pleasure. We would like to show our gratitude Mr. Abdel-Malek, professor of New Jersey Institute of Technology for giving us a good guideline for assignment throughout numerous consultations. We would also like to expand our deepest gratitude to all those who have directly and indirectly guided us in writing this assignment.

We are also grateful to New Jersey Institute of Technology for provision of expertise, and technical support during this project. Without their superior knowledge and experience, the Project would like in quality of outcomes, and thus their support has been essential.

Nevertheless, we express our gratitude toward our families and colleagues for their kind co-operation and encouragement, which help us in completion of this project.

## Table of contents

1.	Introduction and executive summary .....	6
2.	Inventory Management approach to the industry .....	7
2.1.	Inventory .....	7
2.1.1.	Definition of Inventory.....	7
2.1.2.	Purpose of Inventory .....	8
2.1.3.	Inventory Cost.....	10
2.1.4.	Independent and Dependent Demand .....	11
2.2.	Inventory Management System.....	13
2.2.1.	Scope.....	14
2.2.2.	Mission.....	15
2.2.3.	Discipline Relationship .....	17
2.2.4.	Business Function Interfaces .....	17
2.2.5.	System Management Interfaces .....	19
2.2.6.	Roles and Responsibilities.....	19
2.3.	Warehouse Management .....	20
2.3.1.	Receiving and Shipping .....	21
2.3.2.	Storage.....	22
2.3.3.	Order Picking.....	23
2.4.	Inventory Management Basics.....	24
2.4.1.	How to label inventory.....	24
2.4.2.	How to name your inventory locations .....	25
2.4.3.	How to label your locations .....	26
2.4.4.	How to create good inventory items numbers.....	26

2.4.5.	How to create units of measure .....	28
2.5.	Current Issues .....	29
2.6.	Benefits of applying an Inventory Management System .....	30
3.	Alternative solutions .....	31
3.1.	Software procurement.....	31
3.2.	Layout.....	34
3.2.1.	Actual Layout of the Warehouse at Boyko’s Metal Finishing .....	34
3.2.2.	Option one for the New Layout – numbering racks. ....	35
3.2.3.	Option two for the new layout – numbering aisles. ....	39
3.2.4.	Option three for the new layout – numbering sides of racks.....	41
3.3.	Application of the software to the actual process.....	44
4.	Proposed solution and Implementation .....	47
4.1.	Proposed solution .....	47
4.2.	Implementation of OZOfficeInventory to the actual process.....	50
4.3.	Implementation of WASP.....	51
4.4.	Implementation Costs, evaluation of the equipment.....	53
4.5.	Problems during Implementation.....	54
5.	References Cited .....	55
6.	Appendix .....	56
6.1.	Appendix 1. OZOfficeInventory User Manual .....	56
6.2.	Appendix 2. WASP Inventory Control 7 User Manual.....	80
6.3.	Appendix 3. Small racks. ....	94
6.4.	Appendix 4. Large Rack .....	94



## **1. Introduction and executive summary**

Boyko's Metal Finishing CO. is a facility located in Newark, New Jersey, that encompasses 2,500 sqft. This organization primarily operates in the powder coating industry within the Fabricated Metal Products sector, providing powder coating, metal finishing, enameling, metal spraying, and hot dipping services. This organization has been operating for approximately 56 years. The company hires 20 – 49 employees and has an annual revenue of \$2.5 to \$5 million. The company was once located across the street at 85-87 Poinier St, Newark. They moved to their current location, 100 Poinier St, Newark, to expand and better their business.

This project has the aim of helping Boyko's Metal Finishing CO. to improve the control over the powder coating boxes' stock and utilization, applying a commercial software to the actual manufacturing process of the company.

First of all, we studied different possibilities about how to apply an Inventory Management and Control System. After deciding what solution we were going to propose, we studied how to improve the actual warehouse layout and how to codify it for using it as an input in our system. After that, the implementation was one of the biggest issues, studying different ways on how to use the software for obtaining as much profit as possible from it for our application.

The implementation of the solution, equipment and process costs as well as a user manual for the software have been developed and included in this report for a clear and deeper understanding of the tool.

The main contribution that we expect from this project is that Boyko's Metal Finishing CO. will save money and time at the manufacturing process from applying our recommendations.

## **2. Inventory Management approach to the industry**

### **2.1. Inventory**

#### **2.1.1. Definition of Inventory**

Inventory is the stock of any item or resource used in an organization. An inventory system is the set of policies and controls that monitor levels of inventory and determine what levels should be maintained, when stock should be replenished, and how large orders should be. By convention, manufacturing inventory generally refers to items that contribute to or become part of a firm's product output. Manufacturing inventory is typically classified into raw materials, finished products, component parts, supplies, and work-in-process.

In distribution, inventory is classified as in-transit, meaning that it is being moved in the system, and warehouse, which is inventory in a warehouse or distribution center. Retail sites carry inventory for immediate sale to customers. In services, inventory generally refers to the tangible goods to be sold and the supplies necessary to administer the service.

The basic purpose of inventory analysis, whether in manufacturing, distribution, retail, or services, is to specify when items should be ordered and how large the order should be. Many firms are tending to enter into longer-term relationships with vendors to supply their needs for perhaps the entire year. This changes the "when" and "how many to order" to "when" and "how many to deliver."

### **2.1.2. Purpose of Inventory**

All firms keep a supply of inventory for the following reasons:

1. To maintain independence of operations. A supply of materials at a work center allows that center flexibility in operations. For example, because there are costs for making each new production setup, this inventory allows management to reduce the number of setups. Independence of workstations is desirable on assembly lines as well. The time that it takes to do identical operations will naturally vary from one unit to the next. Therefore, it is desirable to have a cushion of several parts within the workstation so that shorter performance times can compensate for longer performance times. This way the average output can be fairly stable.
2. To meet variation in product demand. If the demand for the product is known precisely, it may be possible (though not necessarily economical) to produce the product to exactly meet the demand. Usually, however, demand is not completely known, and a safety or buffer stock must be maintained to absorb variation.
3. To allow flexibility in production scheduling. A stock of inventory relieves the pressure on the production system to get the goods out. This causes longer lead times, which permit production planning for smoother flow and lower-cost operation through larger lot-size production. High setup costs, for example, favor producing a larger number of units once the setup has been made.
4. To provide a safeguard for variation in raw material delivery time. When material is ordered from a vendor, delays can occur for a variety of reasons: a normal variation in shipping time, a shortage of material at the vendor's plant causing backlogs, an unexpected strike at the vendor's plant or at one of the shipping companies, a lost order, or a shipment of incorrect or defective material.
5. To take advantage of economic purchase order size. There are costs to place an order: labor, phone calls, typing, postage, and so on. Therefore, the larger each order is, the fewer the orders that need be written. Also, shipping costs favor larger orders—the larger the shipment, the lower the per-unit cost.

6. Many other domain-specific reasons. Depending on the situation, inventory may need to be carried. For example, in-transit inventory is material being moved from the suppliers to customers and depends on the order quantity and the transit lead time. Another example is inventory that is bought in anticipation of price changes such as fuel for jet planes or semiconductors for computers. There are many other examples.

For each of the preceding reasons, be aware that inventory is costly and large amounts are generally undesirable. Long cycle times are caused by large amounts of inventory and are undesirable as well.

### 2.1.3. Inventory Cost

In making any decision that affects inventory size, the following costs must be considered:

1. Holding (or carrying) costs. This broad category includes the costs for storage facilities, handling, insurance, pilferage, breakage, obsolescence, depreciation, taxes, and the opportunity cost of capital. Obviously, high holding costs tend to favor low inventory levels and frequent replenishment.
2. Setup (or production change) costs. To make each different product involves obtaining the necessary materials, arranging specific equipment setups, filling out the required papers, appropriately charging time and materials, and moving out the previous stock of material. If there were no costs or loss of time in changing from one product to another, many small lots would be produced. This would reduce inventory levels, with a resulting savings in cost. One challenge today is to try to reduce these setup costs to permit smaller lot sizes. (This is the goal of a JIT system).
3. Ordering costs. These costs refer to the managerial and clerical costs to prepare the purchase or production order. Ordering costs include all the details, such as counting items and calculating order quantities. The costs associated with maintaining the system needed to track orders are also included in ordering costs.
4. Shortage costs. When the stock of an item is depleted, an order for that item must either wait until the stock is replenished or be canceled. When the demand is not met and the order is canceled, this is referred to as a stock out. A backorder is when the order is held and filled at a later date when the inventory for the item is replenished. There is a trade-off between carrying stock to satisfy demand and the costs resulting from stock outs and backorders. This balance is sometimes difficult to obtain because it may not be possible to estimate lost profits, the effects of lost customers, or lateness penalties. Frequently, the assumed shortage cost is little more than a guess, although it is usually possible to specify a range of such costs.

Establishing the correct quantity to order from vendors or the size of lots submitted to the firm's productive facilities involves a search for the minimum total cost resulting from the combined effects of four individual costs: holding costs, setup costs, ordering costs, and shortage costs. Of course, the timing of these orders is a critical factor that may impact inventory cost.

#### 2.1.4. Independent and Dependent Demand

In inventory management, it is important to understand the trade-offs involved in using different types of inventory control logic. Figure 1 is a framework that shows how characteristics of demand, transaction cost, and the risk of obsolete inventory map into different types of systems. Transaction cost is dependent on the level of integration and automation incorporated in the system. Manual systems such as simple two-bin logic depend on human posting of the transactions to replenish inventory, which is relatively expensive compared to using a computer to automatically detect when an item needs to be ordered. Integration relates to how connected systems are. For example, it is common for orders for material to be automatically transferred to suppliers electronically and for these orders to be automatically captured by the supplier inventory control system. This type of integration greatly reduces transaction cost. The risk of obsolescence is also an important consideration. If an item is used infrequently or only for a very specific purpose, there is considerable risk in using inventory control logic that does not track the specific source of demand for the item.

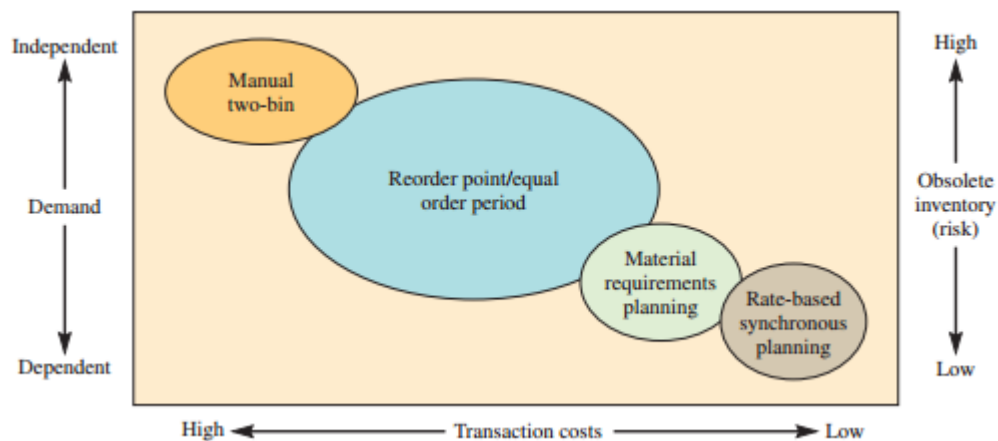

Figure 1 - Dependent & Independent Demand

Further, items that are sensitive to technical obsolescence, such as computer memory chips and processors, need to be managed carefully based on actual need to reduce the risk of getting stuck with inventory that is outdated. An important characteristic of demand relates to whether demand is derived from an end item or is related to the item itself. We use the terms independent demand and dependent demand to describe this characteristic. Briefly, the distinction between independent and dependent

demand is this: In independent demand, the demands for various items are unrelated to each other. For example, a workstation may produce many parts that are unrelated but that meet some external demand requirement. In dependent demand, the need for any one item is a direct result of the need for some other item, usually a higher-level item of which it is part. In concept, dependent demand is a relatively straightforward computational problem. Needed quantities of a dependent-demand item are simply computed, based on the number needed in each higher-level item in which it is used. For example, if an automobile company plans on producing 500 cars per day, then obviously it will need 2,000 wheels and tires (plus spares). The number of wheels and tires needed is dependent on the production levels and is not derived separately.

The demand for cars, on the other hand, is independent —it comes from many sources external to the automobile firm and is not a part of other products; it is unrelated to the demand for other products. To determine the quantities of independent items that must be produced, firms usually turn to their sales and market research departments. They use a variety of techniques, including customer surveys, forecasting techniques, and economic and sociological trends. Because independent demand is uncertain, extra units must be carried in inventory.

## 2.2. Inventory Management System

Inventory Management is an enterprise-wide discipline concerned with the identification and tracking of Information Services (IS) hardware and software assets. Its three main areas of concern are:

1. Acquisition procedures are established to assist personnel in procurement of software and hardware products. Its main purpose is to ensure that proper justifications are performed and that financial guidelines are followed.
2. Redeployment procedures are responsible for ensuring that assets are tracked when moved from one location to another and that budgetary considerations are adjusted as needed. Should a product be moved in conjunction with its original owner then the Inventory System is updated to reflect the new location. Should a product location and owner change, then the Inventory System must be updated to reflect the new owner and their location. In this case, the old product is deleted from the original owner's budget and added to the new owner's budget.
3. Termination is responsible for deleting the asset from the inventory when it is discontinued, or replaced. The owner's budget will be updated to reflect the asset termination and the asset will no longer be listed when location reports are generated.

The Inventory System is maintained within a database that ties an asset to its owner and defines the location where the asset resides. The relative importance of the asset is added to the inventory record. Based on this information the contingency planning specialist can plan asset recoveries needed to support critical business operations. Like all databases, the Inventory System will only be effective if its information is kept current. To ensure the accuracy of the Inventory System, while not adding too great a burden to company personnel, every effort must be taken to implement processes that maintain inventory data with a minimum work effort from personnel.

Inventory Management provides:

- Up-to-date information about data processing resources through the creation and archiving of records in a centralized repository.
- Financial records specific to a single component, or groups of components.
- Service records for all components in the inventory.



- Data used to support configuration diagrams of the hardware and software components contained within specific locations, or the entire data processing environment.

### **2.2.1. Scope**

The Inventory Management discipline encompasses all system and data network elements from the mainframe through the server level to the PC or end component throughout the enterprise. All mainframe and data network based hardware and software assets must be identified and entered into the Inventory System. Any changes to these environments must be reflected in the Inventory System. Financial and technical product information must be available through the Inventory System, as needed to support the functional responsibilities of personnel within the finance and contracts management departments.

Asset criticality must be included with asset descriptive and financial information, so that the Recovery Management department is supplied with the information it requires. Recovery actions must be implemented to safeguard critical assets. The Standards and Procedures Manual section relating to Inventory Management must be created and published. This section must describe the process by which assets are identified, entered into the Inventory Management System, tracked, and finally deleted.

All information needed by personnel to perform Inventory Management functions must be clearly described within this S&P Manual section. Finally, personnel responsible for implementing, supporting, and maintaining assets must have access to the Inventory Management System to identify asset information needed by them to perform their functional responsibilities. This process includes logging the availability of assets, their support history, and any maintenance activity performed on the asset.

### **2.2.2. Mission**

The mission of an Inventory System is to provide a Central Asset Repository of information used to define assets and relate the asset to its owner, location, and relative importance. This information will provide personnel with data needed to support their job functions, for example: Facilities Management will be able to plan Heating, Ventilation and Air Conditioning (HVAC) requirements, as well as power and floor space needed to support equipment listed in the Asset Repository for a specific location.

Financial Services will be able to budget for asset procurement, depreciate assets over time, and prepare complete tax documents. Contracts Management will be able to negotiate vendor discounts and enterprise agreements. Contingency Planning personnel will be able to develop recovery plans for mainframe and office assets contained within the Inventory System based on the assets relative importance (as stated within the Criticality field).

Technical personnel will be able to resolve problems more quickly with the information contained within the Inventory System, because they will have a listing of the assets contained within a location and any support or maintenance activities associated on the asset.

The Inventory System should be integrated within the everyday functions performed by personnel associated with entering and maintaining asset information. The system will reduce the effort devoted to asset management, while supplying many personnel with the information they need to perform their functional responsibilities.

Every effort should be made to develop a central Asset Repository that covers the entire enterprise, rather than having separate Asset Repositories for mainframe, network, and distributed environments. Having a single repository will simplify accounting and asset management, while allowing for the implementation of enterprise-wide asset management standards and procedures.

The objective of Inventory Management is to manage the physical and logical properties of I/S resources and their relationship, while ensuring that service level commitments are achieved. This process will:

- Ensure efficient and timely identification of vital corporate assets.
- Assist in managing the enterprise-wide inventory.
- Provide a common repository for asset protection.
- Plan and control the proliferation of assets across the enterprise.

The objectives of Inventory Management are:

- To identify and track all data processing assets in an Inventory System Repository.
- To define the process by which assets are identified and maintained in the Inventory System.
- To provide Inventory System access to all necessary personnel (data entry, view, update and deletion).
- To provide a full range of reports that will satisfy informational requirements.
- To document the Inventory Management System within the Standards and Procedures Manual.
- To provide training to personnel responsible for supporting the Inventory Management System.

### **2.2.3. Discipline Relationship**

To ensure the integrity of the process, Inventory Management must interface with multiple business and I/S system management functions. The interface to these functions provides the foundation for strong Inventory Management practices.

### **2.2.4. Business Function Interfaces**

Some of the more common business functions that interface with Inventory Management include:

- *Purchasing*: this resource manages all information systems requirement identification through the procurement process. Inventory Management provides input to Purchasing in terms of system and network standard asset information.
- *Accounts Receivable / Payable Department*: this function collects usage data and bills information System (I/S) expenses to the appropriate users. It supports accounting, budget planning, tracking of project costs, and other activities. Inventory Management provides financial records as input to the Accounts Receivable / Payable process and vice versa. This two-way interface occurs with the approval and submittal of billings for payment.
- *I/S Management Committees*: these groups investigate tools and services to provide policy information and translate that data into recommendations for I/S productivity improvements and services. Inventory Management will provide input to these groups in terms of product standards and technology strategies.
- *Strategic Planning Committees*: these groups deal with long-range planning and the integration of I/S objectives with the business objectives of the enterprise. Inventory Management provides an interface to Strategic Planning by providing insight into device migration patterns, trends, and direction, and the Strategic Planning Committees provide information back to the disciplines as well.

- *Security Department*: this function manages the registration or enrollment of people and programs to access controlled I/S resources. Inventory Management provides input about device configurations and security interfaces to this functional area.
- *User Support Groups*: since these groups are responsible for their equipment acquisition, they must be compliant with the inventory process. Tracking the acquisition of network and computer equipment at the local level can be difficult without their full participation. To ensure accountability of such purchases, provisions should be made for a periodic physical inventory of such groups to ensure a level of inventory integrity.
- *Client Support Services*: these groups define the services that will be needed to support the I/S clients within the enterprise. Within Services Management are two key areas:
  - *Help Desk* - This area provides a single point of contact for clients to request services and obtain resolutions for problems.
  - *Service Level Planning* - This area identifies the agreement between the I/S organization and the user community that defines the level of service. The service level agreement is also used to define policies for operations and performance management.

### **2.2.5. System Management Interfaces**

The Inventory Management discipline is dependent upon various disciplines and functions within the enterprise in achieving its objectives. These disciplines and functions and the assumptions related to their tasks are listed below:

- *Change Management:* coordinates the various tasks performed in configuration change and testing across the data processing environment. Any changes to the I/S environment that affect Inventory Management will be inputted from this discipline.
- *Problem Management:* assists the I/S organization in locating, identifying, and resolving inventory problems. The Problem Management discipline will provide input to Inventory Management as problems arise that require changes to resolve conflicts.
- *Facilities Planning:* required to participate in the Problem or Change process as they pertain to the physical environment and is accountable for any actions needed to adhere with the inventory management process. It is essential that the Facilities Planning group provides input to Inventory Management and vice versa, to ensure changes in physical asset configurations are noted.

### **2.2.6. Roles and Responsibilities**

*Inventory Manager:* the Inventory Manager is responsible for maintaining the Inventory in a current and accurate state. Role is responsible for both mainframe and network resident devices and software components. The Inventory Manager interfaces with Systems Management disciplines and the Financial Department.

*Inventory Clerks:* inventory Clerks are responsible for maintaining the Inventory Data Base Repository and for guarantying the information contained within the Repository is accurate and in a current state. Information is data entered, or entered via automated tools.

## 2.3. Warehouse Management

Warehouses are essential components of any supply chain. In a warehouse items are handled in order to level out the variability and imbalances of the material flow caused by factors such as seasonality in demand, production scheduling, transportation, and consolidation of items. Inventories in warehouses are capital intensive assets that require storage areas, handling equipment, and information systems. In addition, warehouse operations are repetitive, labor intensive activities. The capital and operating costs of warehouses represent about 20-25% of the logistics costs. Therefore, improvements in the planning and control of warehousing systems can contribute to the success of any supply chain.

A warehouse is typically divided into functional areas that are designed to facilitate the material flow. The main warehouse areas are outlined in the following: receiving area, reserve and forward storage area, and shipping area. Operations in the receiving area include the processing (i.e., unloading) of carriers, item identification, and quantity and quality inspection. Received items are then moved to a storage area or directly to the shipping area.

The storage area is often divided into a reserve and a forward storage area. The reserve storage area covers typically distant and heavily accessible locations, e.g., the uppermost part of a rack, and is used to ensure the replenishment for the forward storage area. Customer demand is primarily satisfied from the forward storage area, where the items are typically stored in convenient size and the storage locations are easily accessible.

In the shipping area, items are sorted, consolidated and loaded on the carriers. While this is a general material flow in a warehouse, the actual material flow depends mainly on the role of the particular warehouse in the supply chain.

In a typical warehouse 65% of the operating expenses are consumed by order picking, which includes the item picking to replenish the forward area and to full- fill customer order. Therefore, this thesis focuses on those decision problems and warehouse systems that aim to reduce or even eliminate the order picking costs. However, order picking costs can be further reduced by directly moving items from the receiving to the shipping area, that is, by cross-docking.

Operation decisions define the material flow in a warehouse, which is elaborated in the following. First, items arrive and received in the facility. Then the item is either forwarded to the shipping area or allocated in a storage location. The best storage location is close to a dock so that the cost of:

- unloading the items at a dock and transporting them to the storage area
- accessing items and transferring them to a dock for loading is minimized.

As a result, items compete for storage locations that are closest to the docks. When an order is received, the picker retrieves the ordered items. Note that the retrieval can be triggered either by an order for item replenishment in the forward storage area or by a customer order. To ensure efficiency, the picker should follow a route that minimizes the cost of the retrieval. Order consolidation can be considered to facilitate an efficient picking. The sorting is necessary if items have to be clustered by customer order after the completion of the picking. Finally, items are loaded on the carriers and shipped. The main stages in this process are: receiving, storage, order picking, and shipping.

### **2.3.1. Receiving and Shipping**

Receiving and shipping are warehouse operations, which represent two extreme connection points of the warehouse procedures. Receiving includes typically carrier processing (i.e., unloading), item identification, recording the goods receipt, quantity and quality inspection, unpacking, and sorting activities; whereas, shipping includes finishing, batching, packing, and loading operations. The truck-to-dock assignment problem emerges in multi-door warehouses, where a set of docks are available to process a set of carriers and the problem is to assign the docks to the carriers so that some performance criteria are met. The authors present a bilinear objective formulation and provide a local search algorithm. When several trucks are to be processed at a facility with limited number of docks, the truck scheduling policy determines the order of trucks. That is, the truck scheduling problem is the problem of defining the start and completion times for the processing of each truck so that some performance criteria are met. In this problem, the time dimension is taken into account; hence the objective function also tends to be time-related, such as the minimization of make-span, defined as the completion time of the last outbound vehicle.



### 2.3.2. Storage

Storage is the process of allocating items in the warehouse. Since warehouse storage locations and pickers are generally scarce resources, therefore high allocation efficiency is required in terms of utilization of both picker effort and storage capacity. Storage includes the following interrelated activities: sequencing and consolidation, storage location assignment, and shuffling. The storage location assignment policy determines where a given item is stored. The main difference between the product allocation and the storage location assignment problems is that the former considers the reserve and forward storage areas and product volumes, while latter focuses typically on multiple locations and individual items. Storage location assignment policies can be classified into two main groups, namely, dedicated and shared policies. Dedicated storage location assignment commits compartments to products during the planning horizon. This policy requires a high storage capacity to store the maximum inventory of each product. However, once the products and the locations are matched, only the quantity has to be updated at every transaction, therefore this policy improves the transparency and the picker's familiarity with the locations of the different products. Shared storage location assignment allows the compartment to accommodate different products; therefore, the location may be potential for any product upon necessary capacity and product-location compliance. This policy can be computationally intensive. However, the main advantage of it is that the storage capacity required must only fulfill the peak inventory level of all products during the planning horizon. That is, the storage capacity requirement with the shared storage location assignment is lower. Random storage location assignment policy allocates items to locations with equal likelihood resulting in leveled storage space utilization. When comparing the performances of different methods, the random assignment is usually applied as a benchmark. In practice, items are commonly allocated to the available compartment closest to the I/O point; this method is called the closest-open-location policy. However, the performance of the closest-open-location policy is often approximated by applying the random policy. Product characteristics can be incorporated in the decision to improve the performance. Information about product popularity, which is the average number of retrieval orders during the planning period, can be used to reduce expected storage and retrieve time.

The most frequently ordered product is assigned to the location closest to the I/O point, the second most frequently ordered product to the second closest location, etc. Therefore, high-runner items are placed at the easiest accessible locations, while low-demand items are allocated farther, this facilitates that the expected storage/retrieval time is low. However, such a policy may increase aisle congestion and create unbalanced utilization.

### **2.3.3. Order Picking**

An order consists of a set of order lines, which indicate the product code and the required quantity. Orders may be clustered to increase the efficiency of the retrieval; this is referred to as order consolidation. A cycle is a route from the I/O point to the requested storage location(s) and back to the I/O point. Single-command cycle policy (or single-address system) allows only either one storage or one retrieval activity at a cycle. A single storage and a single retrieval activity are combined in a dual-command cycle policy (or dual-address system). Finally, multi command cycle policy allows several storage and several retrieval activities within one cycle. When multiple orders request the same product, the items can be picked in batches. In this case sorting is required before delivering the items, i.e., the picked products are divided into smaller quantities corresponding to the orders. Sorting can pursue a sequential or a simultaneous. Order picking can be manual, mechanical or automatic. The configuration of picking systems, including the level of mechanization, may vary among different departments and product groups. The main types of picking systems are the following: picker-less, picker-to-product, and product-to-picker. A picker-less system is a completely automatic system, e.g., items are loaded on a conveyor from an A-frame. In a product-to-picker system the item is transported to the location of the picker, e.g., by using mini-load or carousel. In a picker-to-product system a picker goes to the location of the product, retrieves it, and delivers it to an I/O point or he may place the item on a conveyor belt, the latter case is called a pick-to-belt system.

## 2.4. Inventory Management Basics

The purpose of this section is to walk you through the absolute basic attributes of a pretty good inventory management system and to instruct you in detail about how to implement our recommendations. We say “pretty good” because there are no perfect ways to create the elements of an inventory management system, but there are lots of bad ways. You may be able to improve on our recommendations or your enterprise may have to do things differently, but if you follow our recommendations, you’ll wind up with a pretty good system. The Critical Elements of a Pretty Good Inventory System are:

- Well-organized location names;
- Location labels that are easy to read and unambiguous;
- Unique, short, and unmistakable item numbers;
- Units of measure;
- A good starting count;
- Software that tracks all inventory activity;
- Good policies.

### 2.4.1. How to label inventory

If an item can be stored somewhere that ‘somewhere’ must have a name, and it should be labeled with that name. If it doesn’t, time will be wasted looking for things, people will stock things in the wrong place, locations will get referred to by more than one name, and your inventory will be in constant drift towards disorganization.

- *Item Descriptions*: all of the items should have well defined, unique descriptions, for many of the same reasons that apply to locations. Without good descriptions, people can become confused about whether or not they have stock on an items, or what items needs to be ordered. It can also be hard to search for items in reports, or find similar items when searching your inventory system. Our opinions about creating good descriptions for your items are a little firmer and we’ll explain in greater detail later.

- *Item Numbers*: item numbers also help uniquely identify items, but one of their greatest benefits is lost on people who haven't used a software system to track their inventory: they serve as a shorthand, or abbreviated item description. When you are searching your inventory, making transactions, filling orders, filtering or searching reports, item numbers really come in handy. Instead of typing descriptions that can be hundreds of characters long, and hard to distinguish at a glance, most companies can use items numbers of only five or six characters or numbers in length. It makes it easier to use your inventory software, and anything that makes something easier, improves the chances that it will get done.
- *Units of Measure*: units of Measure, things like "pcs" "ea" "lbs" "bags" etc... give meaning to quantities and they belong in their own separate place, outside of descriptions and the numeric quantity fields. Using well created and consistent units of measure will make stock levels, shipping quantities, and ordering quantities, easier to understand.

#### **2.4.2. How to name your inventory locations**

Location names exist so you know where to put stuff and where stuff is put. Sounds simple, but walk into any business, and you'll find lots of items stored in locations that aren't clearly labeled or don't have a well thought-out, commonly understood name. A location name doesn't need to be too complicated or cryptic. In many enterprises, the people working there day to day will already have common terms they use to describe various locations. If that's the case, then build on the common understanding when you can. If you have lots of locations, bins, large rooms, or large storage areas, then this guide will help you organize your thinking on how to name locations.

1. Break It Down into Zones or Groups
2. Create Section Names
3. Putting It All Together - Detailed Location Names

### **2.4.3. How to label your locations**

Tips on Making and Mounting Labels:

- Your labels should be durable and fixed in place (i.e., don't use magnets or labels that can be easily moved).
- Labels should be easy to read, preferably from across a room.
- Consider using easy-to-spot colors such as black on yellow or white on red. (If you decide that easy-to-spot colors are too "ugly" or you can't easily make new labels with the same color scheme, you may not want to do this.)
- It should be easy to change or create labels (use an office printer or label maker to make them).
- They should be mounted so as not to obstruct normal activity or get easily ripped off or damaged.
- They should show the FULL NAME of the location, and no two labels should be the same.

They should have arrows that point to the location, making identifying the correct location easier, especially with shelf labels.

### **2.4.4. How to create good inventory items numbers**

Item identification numbers (item numbers) are used to uniquely identify items that you carry in inventory. Some companies will call them "part numbers", "model numbers", "product codes", SKUs, etc. But whatever you call them, item numbers are important for you and the systems you use. If you or your system can't uniquely identify an item, you can't effectively account for its activity and whereabouts within your inventory. Item numbers also serve as a shorthand for longer item descriptions. Instead of entering an entire name or description for an item, you can use a much shorter item number. This speeds up the process of data entry and inventory management.

Retail products and big companies often use long and complicated numbers for their item numbers. These are fine if you're operating a complex warehouse or retail operation. And if this makes sense for your operation, then you probably already have a numbering scheme and don't need to read much further. But if you want to create a system that's easier to work with and uses your own item numbers, here are some of our recommendations.

### Tips on Creating Item Number Schemes:

- Unless you are forced to do so by something out of your control, never start an item number with a zero. Just trust us on this.
- Avoid using letters that can be confused with numbers. The main culprits are O, I, and L.
- DO NOT use a manufacturer's serial number or part number for your part number. These numbers are often too long and cryptic. Plus, if you switch suppliers, or the manufacturer changes their number, it becomes meaningless to your organization.
- Keep item numbers short, but not so short that they could be mistaken for other numbers (i.e., quantities). 4 to 8 characters will suffice for most organizations.
- Do not load item numbers with meaning; do not try to use the item number to describe your product. This will only make your numbers longer and more complicated. Save this information for the item description.
- Consider using a few letters. Letters will help further distinguish your item numbers from other numbers, and they will greatly increase the number of possible item numbers you can have while keeping the overall item number length as short as possible.
- Using a few letters from the beginning of your item description at the beginning of your part number will make it much easier to look up items in pick lists. For example, if you were creating an item number for "Sauce, Chocolate", you might create the number "SAU101", "Sauce, Caramel" would be "SAU102", etc.
- Do not use characters that might confuse people or software. For example, using a comma in your item number might make it look like a quantity or price. Using a "/" can result in Excel formatting your part number as a date. Symbols such as "<", ">", and "\*" can have unintended consequences when moving data between Clearly Inventory and your spreadsheet program. Try to keep your item numbers simple and alphanumeric where possible.

## 2.4.5. How to create units of measure

“Units of measure” are terms that give meaning to quantities. Common units are ea., pc., ft., lb., gal., etc. When they do their job, you hardly notice them. But if they are missing, confusing, or unclear, they will cause problems, ranging from minor headaches and annoyances to massively expensive blunders. To keep units of measure consistent and to make sure that the people in your organization use the same variations of units, Clearly Inventory allows you to set up a table of "approved" units of measure. You can lock this table so no one can change it. So let's take a second and think about our units of measure before we create our list.

Tips on Creating Units of Measure:

- Unless it will confuse the meaning of the unit of measure, consider keeping all of your abbreviations lowercase. For example, “lb.” instead of “LB” or “Lb” and “ea.” instead of EA.
- Try to incorporate both the singular and plural forms of the unit of measure into one term. For example, instead of having “crate” and “crates” as units, consider one unit of measure called “crate(s)” that can apply to any quantity.
- Try to avoid using multiple units with the same meaning. For example, instead of using both “pc.” and “ea.” (for piece and each), decide on one only.
- The “default unit of measure” should be the units in which you usually purchase or stock an item.

Setting up a consistent style for your units of measure is a good habit. It will make your software and reports look clean and clear, and make many of your lists easier to read. No matter what units of measure you use, or how you apply them, you must remain consistent with their spelling and appearance. You don't want to use ea., ea, Ea, EA, ea(s), and EA. when you want to say “each”. Pick one abbreviation and apply it consistently.

## 2.5. Current Issues

After studying how an Inventory Management System could improve the efficiency of the operations saving money and time we observed that many issues could be solved. The main issues that we observed at the facility are:

- Manual control over the inventory utilization, which led to errors for knowing the total amount of powder used in a specific job.
- Difficulty on finding powder coating boxes stored at the warehouse.
- Loss of productive time.
- Inaccurate knowledge of the total number of boxes available for the jobs.
- Bigger order size, higher costs.
- Higher storage costs.



## 2.6. Benefits of applying an Inventory Management System

Inventory management is a good practice for any company. If you are not keeping a watchful eye on your inventory or counting stock regularly, you are setting yourself up for potential inventory errors and challenges. Proper inventory management really can make or break your business! Keep the following benefits in mind as you weigh the cost of not implementing an inventory management strategy:

- *A good inventory management strategy improves the accuracy of inventory orders.* Proper inventory management helps you figure out exactly how much inventory you need to have on-hand. This will help prevent product shortages and allow you to keep just enough inventory without having too much in the warehouse.
- *A good inventory management strategy leads to a more organized warehouse.* A good inventory management strategy supports an organized warehouse. If your warehouse is not organized, you will have a hard time managing your inventory. Many companies choose to optimize their warehouses by putting the highest selling products together and in easily accessible places in the warehouse. This, in turn, helps speed up the order fulfillment process and keeps customers happy.
- *A good inventory management strategy helps save time and money.* Inventory management can have real time and monetary benefits. By keeping track of which products you have on-hand or ordered, you save yourself the effort of having to do an inventory recount to ensure your records are accurate. A good inventory management strategy also helps you save money that could otherwise be wasted on slow-moving products.
- *A good inventory management strategy increases efficiency and productivity.* Inventory management devices, such as barcode scanners and inventory management software, can help drastically improve your efficiency and productivity. These devices will help eliminate manual processes so your employees can focus on other – more important – areas of the business.
- *A good inventory management strategy keeps your customers coming back for more.* It's a fact that good inventory management leads to what you are constantly striving for – repeat customers. If you want your hard-earned customers to come back for your products and services, you need to be able to meet customer demand quickly. Inventory management helps you meet this demand by allowing you to have the right products on-hand as soon as your customers need them.

### **3. Alternative solutions**

In this section, we are going to present different options for the software procurement and layout rearrangement. The study of different options during the development of our final solution let us to choose the most appropriated options for our application.

#### **3.1. Software procurement**

Software procurement the most important part of this report. The selection of the appropriate tool will determine the potential benefits that the company can obtain from it.

We thought about different options, which include:

1. Create our own Inventory Management and Control System software, creating a database with Microsoft Access and Create Layers with a QR code Generator.

Advantages:

- Inexpensive (Only development costs).
- Easy to use.
- Extremely customized for the application
- Exclusive software for the company.

Disadvantages:

- No support after installation (most of the project components go back to Europe after graduating).
- No experience of the team on programming software from scratch.
- Learning process too long for the duration of the project.
- Maybe difficult to link the QR code Reader with database (input completely manually).
- Labels only contain QR Code.

## 2. Buying a commercial Software and Hardware package.

### Advantages:

- Easy to use (Laser Gun Reader, printer for labels, use of smartphones).
- Guidance and support.
- Customizable and adaptable to the application.
- Periodical updates for the software.
- Software tested by millions of users before.

### Disadvantages:

- Higher costs (from \$50 to \$5000).
- Employees must be trained for using the system.

Based on the duration of the project and the purpose of it, we decided to buy a commercial software and then study the implementation of it into the manufacturing process.

We believe that this is the best option since this is an Industrial Engineering Senior project. Most of us in the future will work in companies where we will have to make decisions about what tools implement for the benefit of the company. We think that programming a software from scratch is out of the scope of an Industrial Engineer and would be more appropriated for students in Computer Science bachelors.

From the different software available, we studied the ones that were more related with our application:

### 1. WASP

Wasp is the only internal software provider from the software studied. The company provided us a demo for testing it. It has many different tools apart of the Inventory Management module. We think that it is a very complete software, maybe too much for the application that we are looking for. There are many modules that are not useful at the first step of the implementation.

For using the software, it is necessary to use their hardware, barcode scanner or laser guns and label printers. The initial investment for this software is around \$3000-\$4000.

## 2. FinaleInventory

Finale inventory is a web based software. It is very complete. The input would be manually, but it is a very user-friendly software, very intuitive. Also, it is possible to import items from Excel files in a very easy way, which could be useful for importing and exporting assets. Standard barcode scanners and printers can be used, connected through usb to a computer. The cost for this software is around \$100-\$200 per month.

## 3. TradeGecko

TradeGecko is a web based software. It is possible to modify stock levels and characteristics in an easier way compared with the others and also standard barcodes scanners work with them. The possibility of using barcodes from suppliers is a good option. However, the level of customization is more restricted and we think that this software is more appropriated for retailers and sellers.

## 4. EZOfficelInventory

Again, this is a web based software can be used from any computer or electronic device. There is also a mobile phone App that can be used to read barcodes and modify characteristics of the inventory, so it is not necessary to buy barcode scanners. Also, labels can be printed from a standard printer, and the software let us create and customize our own labels for the boxes. It is also possible to use the barcodes from the suppliers, that can save time in the input of our system. The cost for this software is around \$50-\$100 per month.

## 3.2. Layout

The purpose of this chapter to evaluate the actual layout and the proposal of the alternatives layouts.

### 3.2.1. Actual Layout of the Warehouse at Boyko's Metal Finishing

This section's objective is to explain the actual layout of the warehouse, which consists of 16 small racks<sup>1</sup> and 8 large shelves<sup>2</sup>.

The dark blue rectangles represent the small racks, while the cyan rectangles are the large ones.

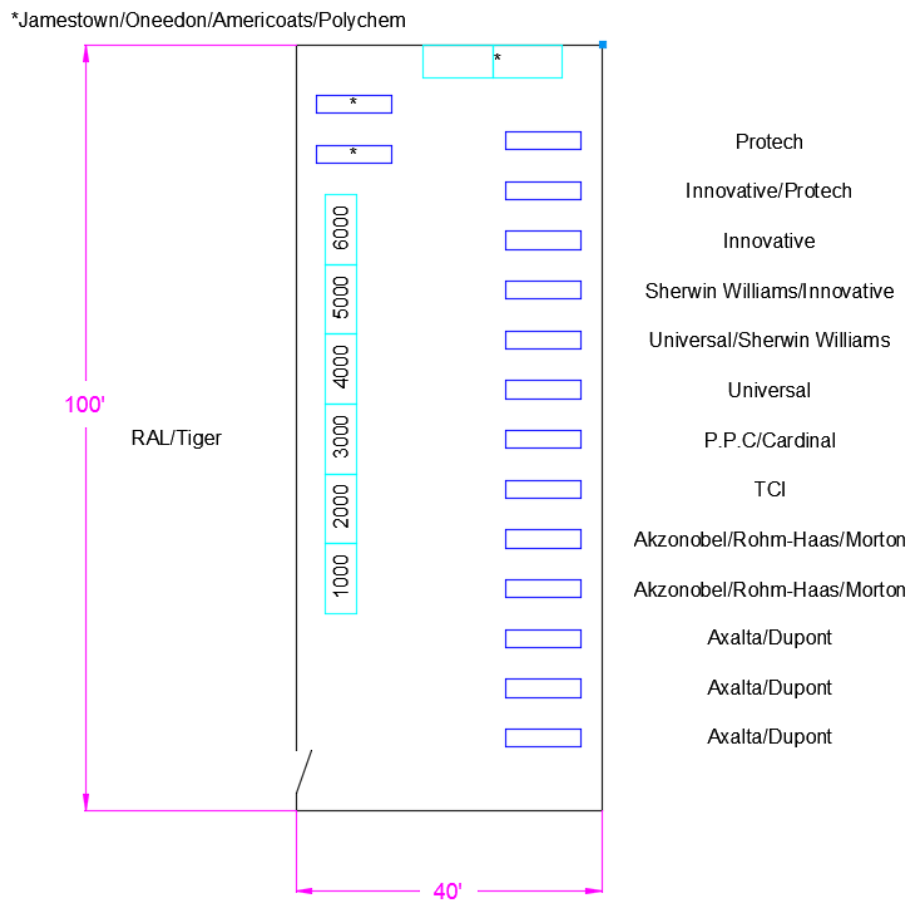

Figure 2 Actual Layout of the Warehouse

<sup>1</sup> Small racks: see the Appendix 3 for a picture

<sup>2</sup> Large racks: see the Appendix 4 for a picture

Nowadays, there is one employee that manages the warehouse and the racks have a paper, in which is written the manufacturers of the boxes in the rack. There is not an exact place to put the boxes, which provokes that sometimes for a new job a full box is taken instead of a used box that contains powder remaining from a previous job.

The large racks in the left sections contains RAL and Tiger boxes, ordered by its color series number: 1000, 2000, 3000, 4000, 5000 or 6000.

### 3.2.2. Option one for the New Layout – numbering racks.

The objective of this new layout is to make easier to define the location of the boxes in the system, so the operator can easily find them by following the location code of the box.

Also, it will provide other advantages, such as the location of the boxes with remaining powder from previous jobs, in order to use them first. The new layout does not change from the original one but it is important to include numeration for the correct understanding of the warehouse by any employee.

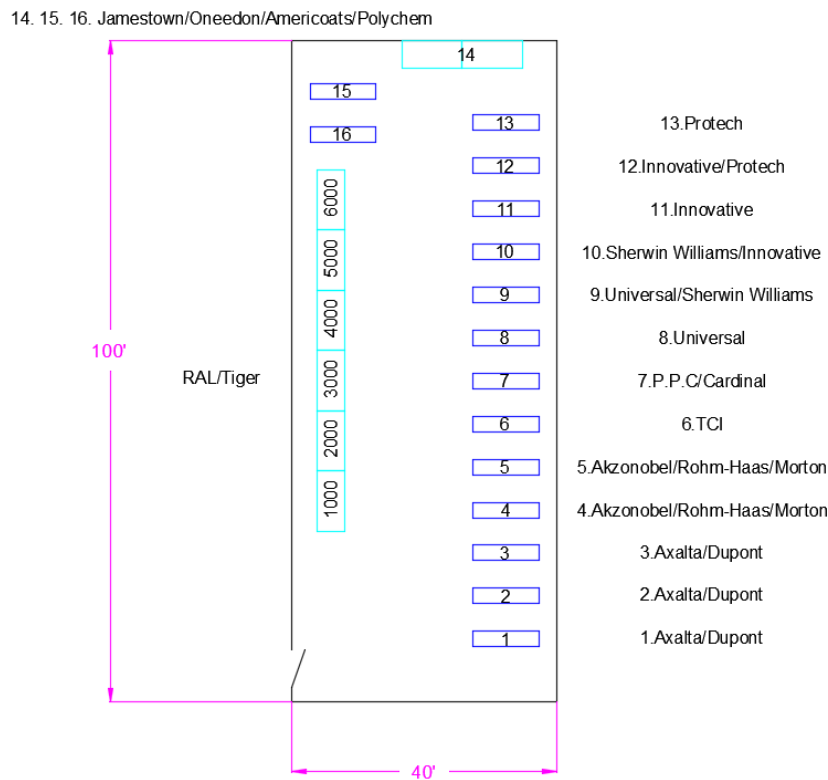

Figure 3 Layout option of numbering racks

As you can notice the manufacturers are still in the same racks because the workers already know this system and changing it could provoke some misunderstandings and they could feel uncomfortable with the new system.

For the perfect location of the boxes the number of the rack is not enough, so it is important to define correctly the position.

First it is important to know the number of the rack, and its relative position. We have decided to use right and left for the right section and front and back for the RAL and Tiger section. Below there are some pictures where you can have visual concept.

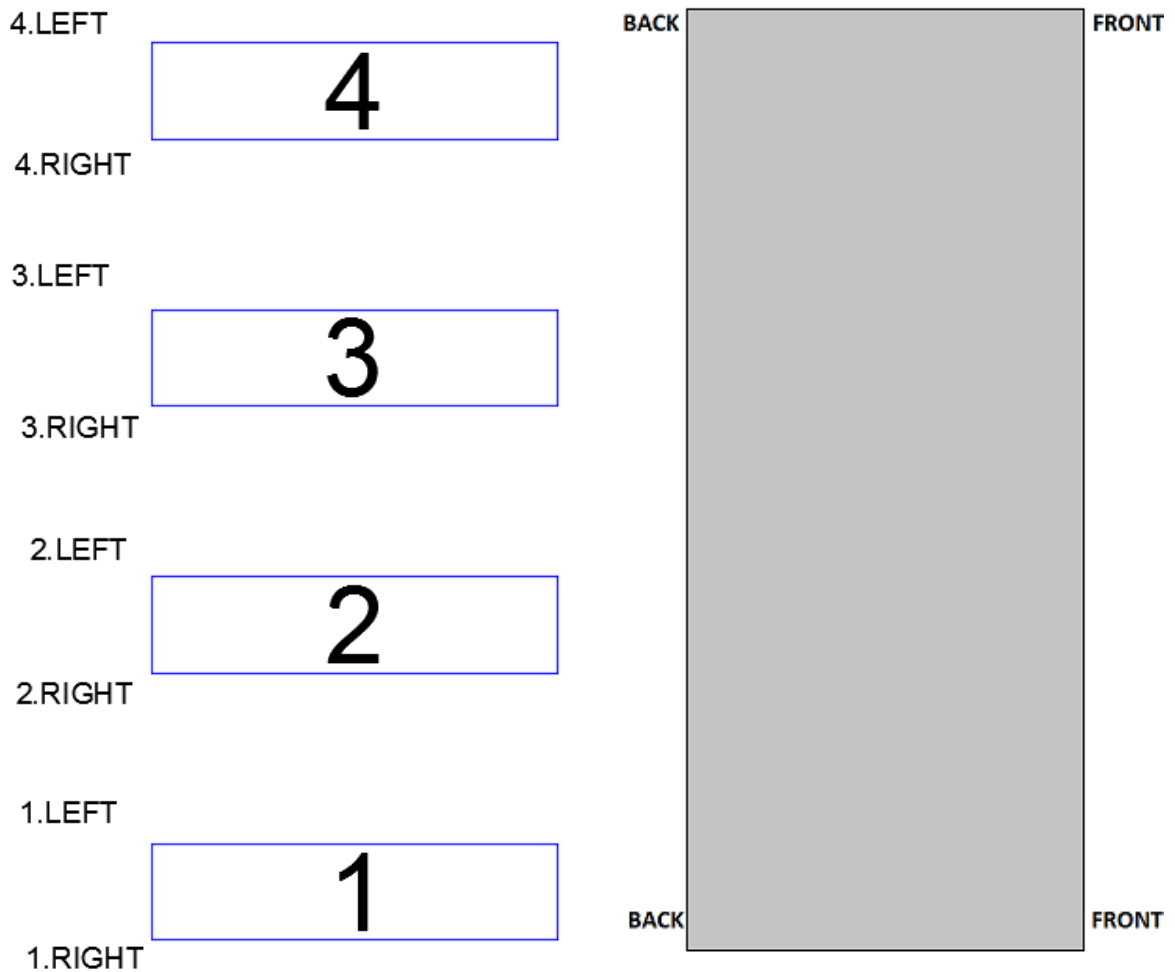
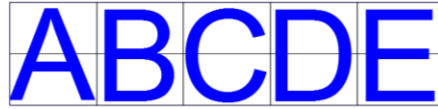

Figure 4 Relative position in the racks of option one

Now that we have the relative position of the box respect to the rack, the level and column is needed.

Each small rack has 5 levels, numerated from the bottom to the top, and each level has 5 columns. These are numerated by letters from A to E. See the figure below.

1.LEFT



1.RIGHT

*Figure 5 Column of the box in the racks*

For the large racks, they follow the same system but they have just 4 levels and 4 columns, so they have the letters from A to D and levels from 1 to 4. With this, the exact location is given. But the operator has also the possibility of writing just the relative position and the level or the column. There is also some special configuration such as number 14 – see the new layout picture-.

For this one, the solution is as follows.

14

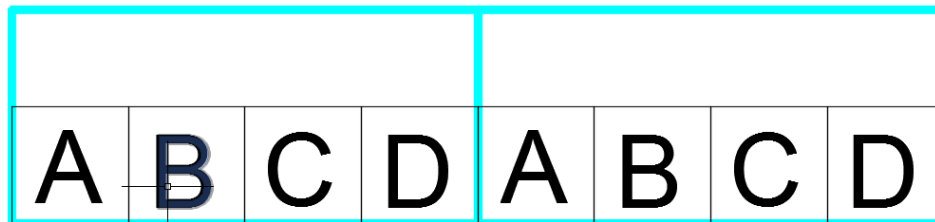

LEFT RIGHT

*Figure 6 Column of the box in the special rack number 14*



To sum up, the location is given by:

- Rack
- Relative position
- Level
- Column

With these four indicators the position will be coded like this:

$$[\textit{number of rack}] \begin{bmatrix} F - \textit{front} \\ B - \textit{back} \\ R - \textit{right} \\ L - \textit{left} \end{bmatrix} - [\textit{level}][\textit{letter of the column}]$$

Here there are some examples for a better understanding:

### **1R-2B**

This box is in the first rack, right side, second level, column B.

### **1000B-2D**

This box is in the RAL 1000 rack, back side, second level, column D.

These are the advantages of this alternative:

- Exact position is given.
- Less numbers to check for finding the box.
- Finding of used boxes is easier.

There is just one disadvantage:

- Mixing two different concepts for location may end in errors.
- More difficult to keep doing with accuracy with a lot of suppliers.

### 3.2.3. Option two for the new layout – numbering aisles.

The objective of this new layout is not to get the employees confused with right and left, so this layout has another format: instead of numerating racks, we are going to numerate aisles. Like the picture below.

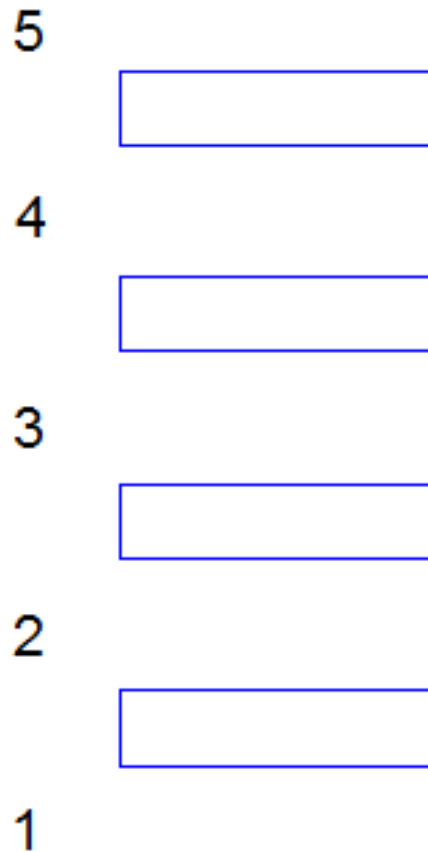

*Figure 7 Method to count aisles*

For this alternative layout our proposal is to use dedicated storage, so the boxes of one manufacturer are located in one specific area and its colors have also a specific space, which can be bigger or smaller depending on the quantity needed and its frequency. But also, inside that reserved area for that color there is a random storage, so the operator puts the box in an empty space of that reserved space.

Furthermore, the boxes will be organized by manufacturers and then by their colors. Some colors like white or black in Axalta/Dupont are more frequent so they have a bigger space than others, such as blue or red which may share an area.

With this method, when the operator has to pick up a box, he knows the specific area o rack in which it is the box and he has to look to 5racks x 4 columns x 2sides=40 boxes.

This can be reduced using numeration for sides of racks – see next alternative layout below -, with this system the employee has to look just to twenty boxes to know which is the one he is looking for.

In this option, the codification of the location of the boxes in the system will follow the next formula:

$$[\textit{number of aisle}] - [\textit{level}][\textit{letter of the column}]$$

But we have to take into account that due to the numbering of aisles, there are two boxes with the same location in our system which this means that they are one in front of the other. But this may cause errors when the employees are going to take the box.

Also, it is also possible to write just the number of aisle and the level or the aisle with the letter of the column or just the aisle.

Here there are some examples for a better understanding:

### **1 - 2B**

This box is in the first aisle, second level, column B.

### **1000**

This box is in the RAL 1000 rack.

These are the advantages of this alternative:

- Easier to use at the beginning.
- Finding of used boxes is easier.
- Only one concept for location

These are the disadvantages:

- Too many boxes to look at for finding just one.
- Specific area is given, not exact position
- Two boxes may have the same location in the system so exact location is not possible.

### 3.2.4. Option three for the new layout – numbering sides of racks.

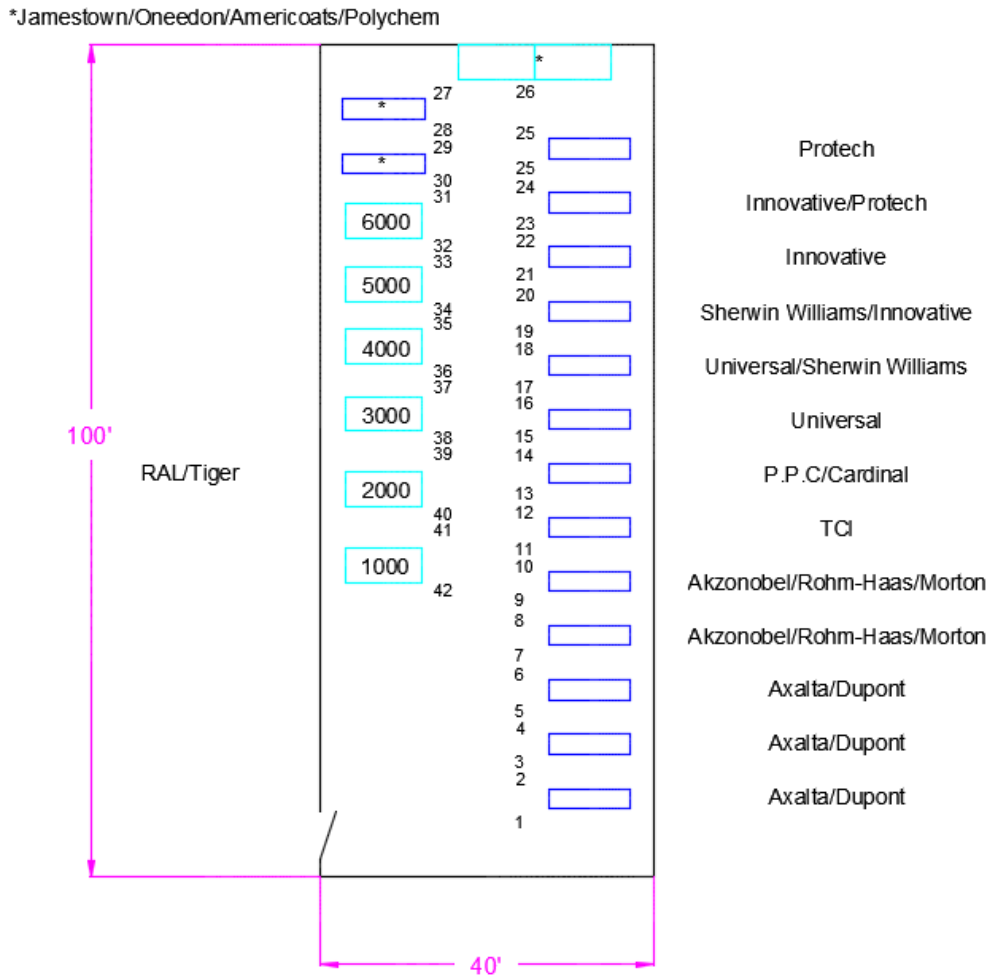

Figure 8 Final Layout, counting sides of racks

As in the chapter 3.2.3, our proposal is to use dedicated storage, so the boxes of one manufacturer are located in one specific area and its colors have also a specific space, which can be bigger or smaller depending on the quantity needed and its frequency. But also, inside that reserved area for that color there is a random storage, so the operator puts the box in an empty space of that reserved space.

With this method, when the operator has to pick up a box, he knows the specific area of rack in which it is the box and he has to look to 5racks x 4 columns x 1side=20 boxes.

With this new Layout each side of a rack will be identified with a number to reduce the number of boxes that the operator has to look in a specified location. This alternative increases the number of locations

but as it has just one concept for location, it will reduce the search time and any new person in the warehouse will understand the system.

Furthermore, the RAL and Tiger racks are turned to follow this numeration and to create more space in the warehouse, so more racks can be added to increase the storage space.

In addition, all the racks will provide information about the numbers of each side of the rack and the manufacturers and colors such as the example below.

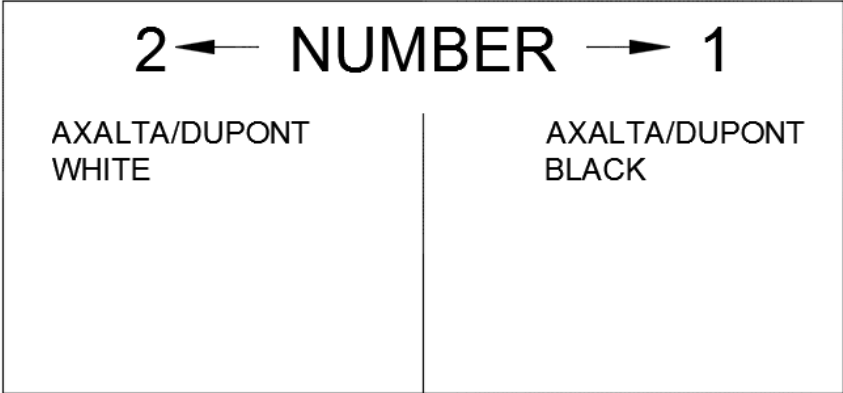

*Figure 9 Label in rack so show content in each side*

The used boxes will have a label in a visible color such as yellow or orange to identify them better.

In the proposed solutions there is not a specific proposed place to put the used boxes because we think that it is better to have the boxes organized by colors and have the used boxes together with the boxes of the same color. This way, when a color is needed the operators will go to that section and find the used box first and take more boxes of the same color instead of going to two different places.

In this option, the codification of the location of the boxes in the system will follow the next formula:

$$[number\ of\ side\ of\ rack] - [level][letter\ of\ the\ column]$$

In this case, there is no possibility of coincidence of the exact location of the boxes.

Also, it is also possible to write just the number of aisle and the level or the aisle with the letter of the column or just the aisle.

Here there are some examples for a better understanding:

**1 - 2B**

This box is in the side 1, second level, column B.

**34-3**

This box is in the side 34, third level.

These are the advantages of this alternative:

- Easier to use at the beginning.
- Finding of used boxes is easier.
- Just 20 boxes to look at when the position in the code is just the side of rack
- Only one concept for location.
- Exact position and specific area coexist in this method.

### 3.3. Application of the software to the actual process

Here we are going to describe different options about how to implement the software in the actual process:

**Option 1:** One person is assigned as responsible for all check-ins and check-outs of the system.

One employee per shift would be assigned as responsible for managing the system. Workers will continue to fill the same sheets with the utilization of powder coating boxes, which would be provided to this person at the end of the shift and will introduce the changes into the system.

Characteristics:

- All check-ins and check-outs from powder coating station are done by this person with the sheet as explained in the User Manual (Appendix). Check-ins of boxes with remaining powder would need a label that should be provided by this employee.
- Addition of new incoming material is also done by this person.
- Changes of position of inventory at the warehouse or movement of material must be notified to this person, and then changed.

Advantages:

- Only one person manages the whole system.
- Workers won't need training.
- Workers won't change their procedures.

#### Disadvantages:

- Workers won't be familiar with the system in case of need.
- Need of training for other employee if responsible resigns or is on sick leave.
- Worked is doubled (registering into sheets and then into system again).
- Information is not updated until the end of the shift.

#### **Option 2:** Workers are responsible for check-ins and check-outs.

Workers at the powder coating station will check-out boxes when they use them and then check-in again if there is powder remaining at the end of a job.

A computer and a printer should be provided to them in order to print labels for the check-ins of remaining powder boxes. Boxes can be easily checked-out with the mobile phone app or the scanners and new incoming material can also be added easily to the system with the app if it already exists (explained in User Manual).

#### Characteristics:

- All check-ins and check-outs from powder coating station are done by the workers at the station as explained in the User Manual. They can print the labels for the boxes with powder coating remaining.
- Information in the system is updated real time. Doing this, jobs can be tracked at real time too.
- Addition of new incoming material can be done by the employee that receives it or before storing it at the warehouse.
- Changes of position of inventory at the warehouse or movement of material can be changed at the system from any place with the mobile phone app.



Advantages:

- Information is updated real time.
- Jobs can also be tracked real time.
- Workers will be familiar with the system.
- All workers get involved with the system, but only few can make changes.
- All changes are registered and can be tracked. Every employee will have a different username.
- Information registration is only done once, directly to the system. We avoid double work.

Disadvantages:

- Responsibility is derived in more people than in option 1.
- Need of a responsible for supervision.
- Need of training and modification of workers' procedures.

## **4. Proposed solution and Implementation**

In this section we are going to describe what solution we think is the best and why. Also, the steps for the implementation of the tool and some problems that could arise during it. We based our decisions in what we thought was best for the company with help from our industrial advisor.

### **4.1. Proposed solution**

We have to take into account that this is the first time for the company that a computer based Inventory Management System is going to be used, so all the employees would need some time to adapt to the new procedures. Based on this, the tool that we are going to implement has to be intuitive and simple to use.

From the different layouts presented before, we are going to choose the third option because it is possible to provide an exact position and a specific area in which the box is located. Furthermore, there is just one concept for the location of the box, which is numbering and it is intuitive. This last advantage makes our system easier to use and any employee can go to take a box to the warehouse.

About the application of the software, we think that all employees should be involved with the system because we will avoid mistakes (one person registers the information manually and a different one registers it into the system) and we want to make sure that everyone participates into the improvement of the company. In addition, only few of them at the powder coating station will be able to make changes, but they all will know about it.

Our proposed solution is to implement OZOfficeInventory at the first step of the implementation until the procedures for using an Inventory Management software are mastered in the company, then, move on and implement a more sophisticated and powerful software, WASP, that contains other modules that are useful for the company and can be used at the same time. All employees will be familiar with the system, but only those at the powder coating station will be able to make changes. All the procedures for using correctly the software are in Appendix 1, not included here because of their extension.

The implementation of the software will start with only one supplier of powder coating boxes (Axalta) since we think that it has more sense to implement it gradually and evaluate its correct use before doing the input for all the boxes at the warehouse.

We are going to use the information that is more relevant for identifying correctly the boxes. This information is needed as an input for the Inventory management system of powder coating boxes:

- Manufacturer Name
- Product Name
- Product Code
- Weight
- Chemistry
- Color
- Gloss
- Surface type

For the labels, we decided that it is a good idea to use the barcodes from the suppliers for the input in our system. Based on our industrial advisor opinion, companies have been working with the same barcodes during the last 20 years. In addition, the company will save time since they won't have to print a new label for every single box. For the used boxes, the company will need to print a personalized label in a bright color for an easier identification, following this model:

**BLACK10-AXALTA-PFR400600**

Where:

BLACK10 – Powder name;      AXALTA – Supplier name;      PFR400600 – Product Code;

Employees are actually controlling the usage of powder filling control sheets. During the firsts weeks, employees should continue filling those sheets and also doing inputs and outputs from the Inventory Management System. Doing this, managers can later check and be sure that the system is used in a correct way and that there are no mistakes.

We think that OZOfficeInventory is the ideal tool for starting our implementation since implementation costs are low and it is a very user friendly software. Then, after employees are used to the procedures, we consider to use WASP as this software contain more modules that can be used and also the Inventory Management module contain more tools that can be implemented.

We decided to implement this solution in the order specified above for the following reasons:

- OZOfficeInventory is an inexpensive tool to implement, around \$50 - \$100 per month; while WASP has higher implementation costs, around \$3000 - \$4000.
- OZOfficeInventory is a very specific software, only does Inventory Management, so we are just implementing one module at a time.
- OZOfficeInventory is very easy to use, operators will learn the procedures using an App in their smartphones. When we move on to WASP they will be used to the procedures, the employees will only need to learn how to use WASP hardware.
- In OZOfficeInventory it is possible to export all the inventory that is inside the system into an EXCEL file, for later importing it into WASP, what will reduce time for implementing WASP.
- WASP provides its own hardware, that is more expensive and not that easy to use at the very beginning. We think it is more appropriate to implement it after learning the procedure for using an Inventory Management software.
- Using OZOfficeInventory at the first step will reduce the risk that the company is assuming. If the implementation is not satisfactory, the company would spend only few hundred dollars, instead of thousands.

## **4.2. Implementation of OZOfficeInventory to the actual process**

As mentioned before, the implementation of the tool will start with the most used powder coating boxes supplier, Axalta. After management controls and ensures that no mistakes are made while using the system, more suppliers will be added to the system until there is a total control over the inventory.

Employees at the powder coating station will be responsible for the input and output of boxes since the powder is used at that station. In the first weeks employees will continue with their manual control over the use of boxes and will make changes at the system; management then will check that no mistakes are made and decide when to add more suppliers to the system.

Employees will need a smartphone or device with internet with the OZOfficeInventory App. Management will control the use of the software from a computer. Nowadays almost every person has a mobile phone with internet access, in that case employees will use their own phones since they are familiar with them and will take more care on not damaging them. In case they do not, they should be provided with a device with the App at the workstation.

The procedures for using the OZOfficeInventory software and App are explained in the Appendix 1. They are not included here because of their extension. For summarizing, here are the steps that they should follow:

- Employees will scan the labels of the boxes for identifying which one are they using.
- Employees will then remove or add stock from the system.
- In case they add used boxes, they will print new labels.

### 4.3. Implementation of WASP

Implementation of WASP Inventory Control 7 will begin first by assigning privileges to employees and management. WASP is a very powerful yet simple software, however when creating new inventory or setting preferences, inputting the wrong data and saving the preference can cause faulty reports that will be faulty unless restarting inventory or waiting until the inventory is at the value of zero. Using the administration tool, we will assign privileges to employees and managers to control who has access to WASP.

After assigning privileges, we will begin to login our current inventory by first creating “items” that will be housed in inventory, then the location of each item. WASP comes with the feature of “Pinning”, “Pinning” is very useful for adding different types of item to the same location and site, without having to enter items manually. Within Boyko, managers or whoever has permission will define (1) item of inventory. When define, whoever has permission will fill out the fills of Item Number (Manufactures or Custom serial number), Manufacturer, Description and method of tracking; which we recommend by lot size since there isn’t any standard number of boxes used per job and each job uses one color per job. After defining the item, managers or whoever has permission will then define location of the (1) item. However, the location preference will be ignored since we had “Pinned” the location to a specific area. Be aware that for each new item of inventory, you must create a new item. After creating a “New Item” and setting up the location preferences, you can then add Inventory one-by-one (Serial), Lot size, Date Code or pallet by using the Inventory Code.

Since we decided that using the barcode from the suppliers will be most efficient, whoever is Adding/Removing boxes will follow the follow the following procedures.

- a. Scan One Box of Powder Coating Paint, View Computer Monitor or WASP mobile monitor. Data will detail designated location and Maximum/Minimum stock level.
- b. Employee will then transport specified inventory to designated location (Rack) and Fill Rack in respect to maximum/minimum stock level. Since we recommended tracking by Lot size, employee will scan one box then manually add number of boxes added.
- c. When removing boxes, located specified box either manually or using wasp find tool.

- d. Since we recommend Lot Size tracking, employee will scan one box, then manually enter how many boxes are going to be remove from the lot.

When Adding used boxes back to Inventory, employees will follow the following procedures

1. Create New Item using Wasp
2. Enter Item Number and fill out general information
3. When select tracking information, select serial number and change the date code box to read as Used Box Weight.
4. Define Location Preferences.
5. Go to Inventory Tool and click add Inventory, scan used box and filled in tracking information (Serial Number of Box and Weight of Box) WASP will not allow you to add box to inventory unless you fill out tracking information.

The Procedures of WASP will be explained in Appendix 2. Within the Appndix it will detail the user how to

1. Assign Privileges
2. Create New Item
3. Define Location
4. Adding/Removing Inventory

#### 4.4. Implementation Costs, evaluation of the equipment

As we know, the implementation of the tools has some initial costs and some equipment should be bought for using it. OZOfficeInventory has lower initial costs, while WASP has higher costs because their hardware must be bought for using the system. Here we are going to describe the initial costs for the application of each tool:

- OZOfficeInventory:

It is possible to use a free trial period of 14 days for evaluating the tool. However, we do not think that is enough time. For using the software, a monthly fee of \$50 to \$100 should be paid, depending on the module implemented (\$50 should be enough at the beginning).

As mentioned before, employees will need a device for using the software with the App. If they use their own smartphone, that won't be a cost for the company. The App only uses few data MB, so that it will not be an impact on employees' normal utilization of their smartphone data plan. In case they do not have one, a device with internet connection should be provided at the workstation. One will be enough since only one person will make changes at the same time. A phone of \$100 dollars and a data plan of \$10 to \$20 per month will be enough.

In addition, a computer with a printer should be provided, as employees at the powder coating station will need to print new labels for the boxes of powder coating that are used.

- WASP:

You are able to trial WASP inventory Control 7 for free after speaking with a sales consultant, who will then email you the trial version of WASP. The sales consultant who help us trial WASP would be the appropriate person to contact to processed with buying a complete version of WASP.

Ross Edwards, Solution Sales Consultant, [Ross.Edwards@waspbarcode.com](mailto:Ross.Edwards@waspbarcode.com)



## 4.5. Problems during Implementation

We thought about some problems that we have right now and could arise during the implementation of the tool and how to overcome them. The main problems are:

- Lack of space at the warehouse:

For this problem, we believe that once the company starts to control the inventory, the number of boxes will be reduced since they will have a total control on the number of boxes that they have and how many more they will need.

Other option that we thought about is the creation of some extra temporary space for storing boxes until this situation is over. For this, we think that they can use a trailer at the parking. Also, the company can put some pallets to storage boxes next to the existing racks, so they will avoid extra trips to the trailer that would be placed at the parking.

- Assignment of space in the racks:

We believe that the best approach is to use dedicated storage; we are going to reserve a certain number of racks for every supplier based on historical data of space needs and the knowledge of our industrial advisor.

Then, inside the racks assigned to each supplier, we are going to divide the space into areas. Each one of these areas will be assigned to a specific color or family of colors. We will also take into account the surface finish and the gloss of the powder for ordering them inside these areas.

We considered the color as the main distinctive characteristic of boxes, under these conditions, we want to avoid the presence of boxes of same colors in different racks even though they are from the same supplier.

## 5. References Cited

- Facility Planning Fourth Edition by James A. Tomkins, John A. White, Yavuz A. Bozer and J.M.A. Tanchoco.
- Warehouse & Distribution Science by John J. Bartholdi and Steven T. Hackman
- Human Factors in Simplex and Complex by Robert W. Proctor and Trisha Van Zandt
- <http://public.csusm.edu/fangfang/Teaching/HTMmaterial/StudentProjectSpring2009/ReportGroup5.pdf>
- <http://dcag.com/images/INVENT01.pdf>
- <http://www.clearlyinventory.com/>
- Benefit of Inventory Management (ww.scanco.com)
- Wasp Software (<http://www.waspbarcode.com/inventory-control>)
- FinaleInventory (<http://www.finaleinventory.com/inventory-management-base>)
- TradeGecko (<https://www.tradegecko.com/>)
- EZOfficeInventory (<http://www.ezofficeinventory.com/>)

**6. Appendix**

**6.1. Appendix 1. OZOfficeInventory User Manual**

Part 1: First addition of powder coating boxes to the system/addition of new boxes (non-existent in the system) ..... 57

Part 2: Print Labels..... 61

Part 3: Remove stock from the system..... 63

Part 4: Add stock to the system (existing material)..... 66

Part 5: Add boxes with remaining powder ..... 69

Part 6: Save your Inventory in an EXCEL file ..... 72

Part 7: Import data from an EXCEL file ..... 74

Part 8: Manage Inputs and Outputs of the system..... 76

## Part 1: First addition of powder coating boxes to the system/addition of new boxes (non-existent in the system)

It is convenient to do this part with the mobile phone App because it can be done in an easy way, a mobile phone is portable and in the warehouse a computer is not available. Also, with mobile phones barcodes can be scanned automatically, we would have to introduce them manually with a computer.

### Mobile phone:

- Step 1: Go into the OZOfficeInventory App, click menu and then “Add Inventory”.

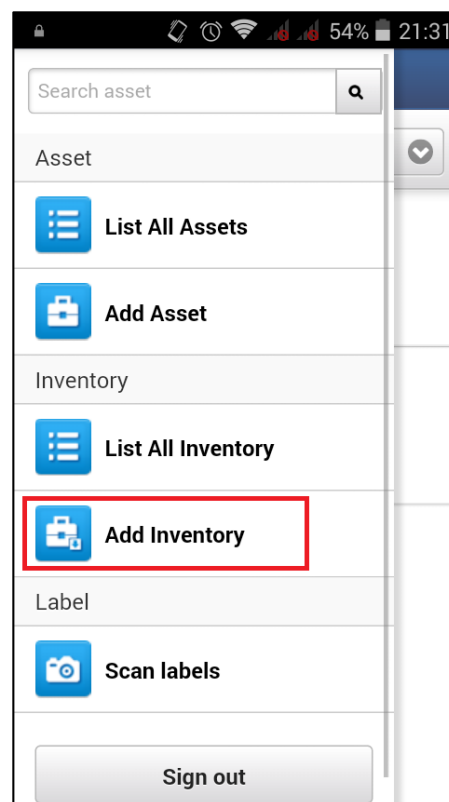
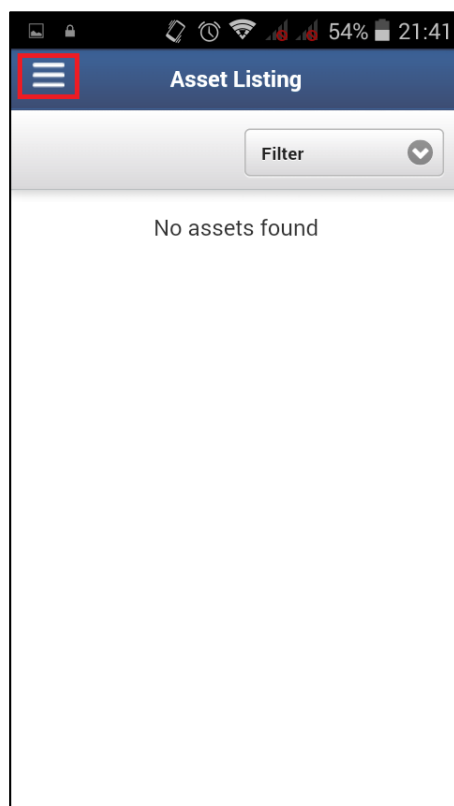

- Step 2: Insert the necessary information and scan the barcode.

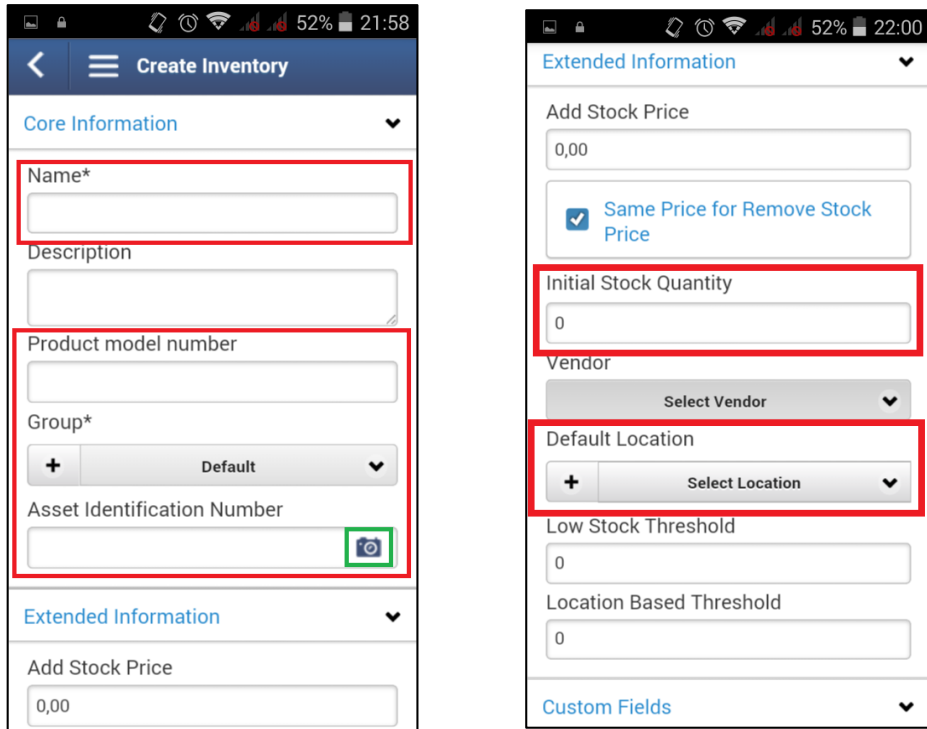

Press the green square and let the application access to your camera for scanning the barcode.

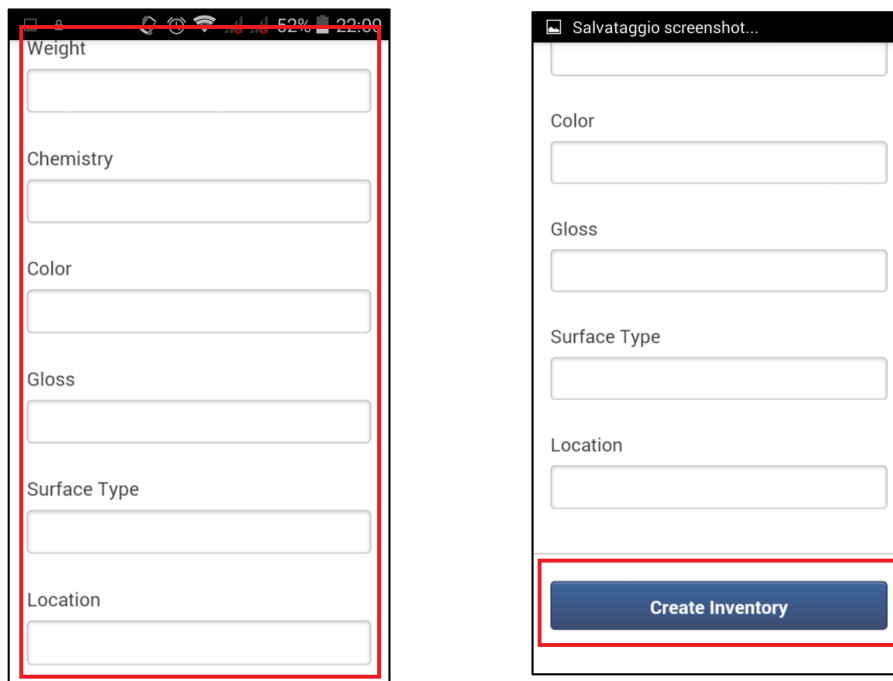

Once you press "Create Inventory" the box will be added to the system.

## Computer:

- Step 1: Go into the OZOfficeInventory site, click “Items” and then “Inventory”. Then select “Add inventory”.

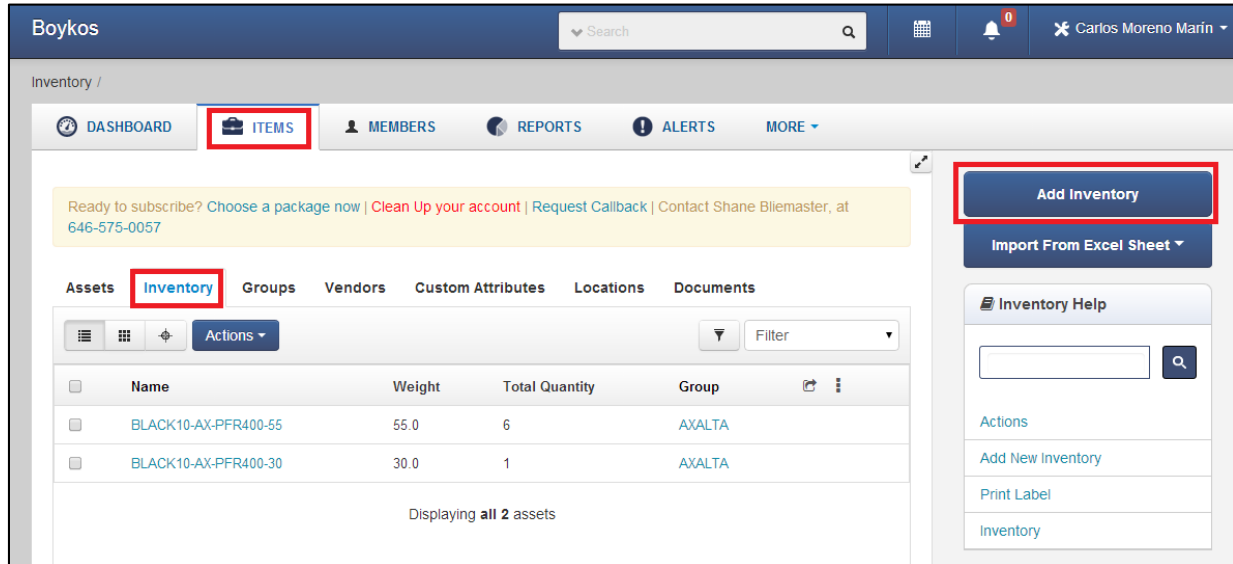

The screenshot shows the Boykos web application interface. At the top, there is a navigation bar with 'Inventory /' and a search bar. Below this is a secondary navigation bar with 'DASHBOARD', 'ITEMS' (highlighted with a red box), 'MEMBERS', 'REPORTS', 'ALERTS', and 'MORE'. A yellow banner at the top of the main content area contains promotional text: 'Ready to subscribe? Choose a package now | Clean Up your account | Request Callback | Contact Shane BlieMASTER, at 646-575-0057'. Below the banner, there are tabs for 'Assets', 'Inventory' (highlighted with a red box), 'Groups', 'Vendors', 'Custom Attributes', 'Locations', and 'Documents'. A table of assets is displayed with columns for Name, Weight, Total Quantity, and Group. Two items are listed: 'BLACK10-AX-PFR400-55' (Weight: 55.0, Total Quantity: 6, Group: AXALTA) and 'BLACK10-AX-PFR400-30' (Weight: 30.0, Total Quantity: 1, Group: AXALTA). On the right side, there is a sidebar with a red-bordered box containing 'Add Inventory' and 'Import From Excel Sheet' buttons. Below this is an 'Inventory Help' section with a search bar and a list of actions: 'Add New Inventory', 'Print Label', and 'Inventory'.

- Step 2: Insert the necessary information.

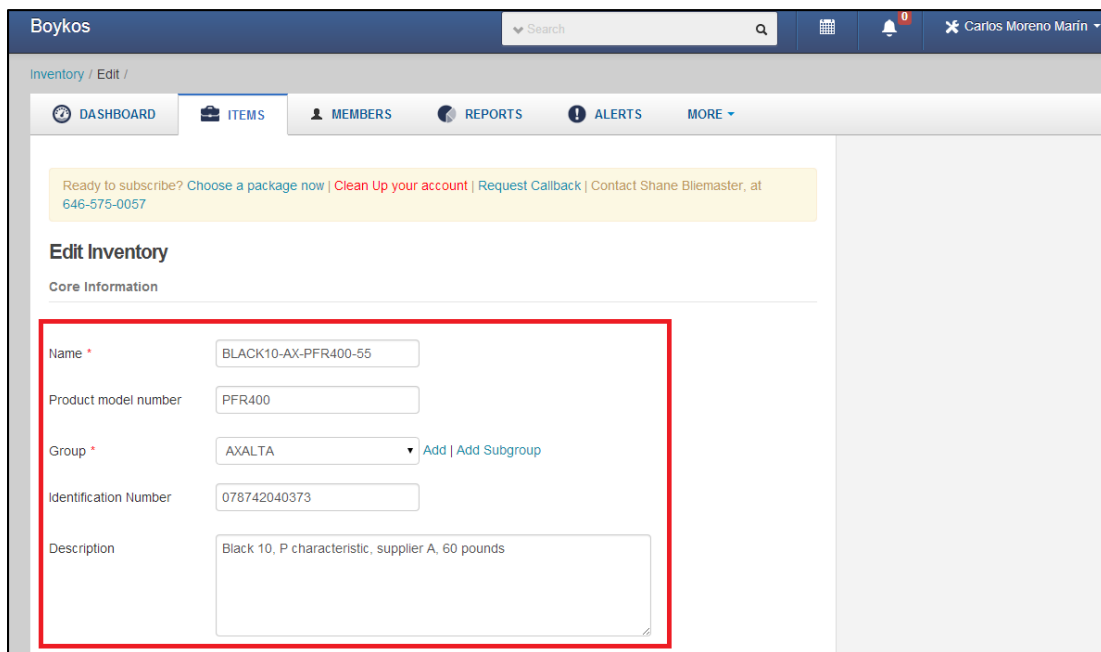

The screenshot shows the 'Edit Inventory' form in the Boykos web application. The form is titled 'Edit Inventory' and has a 'Core Information' section. The input fields are highlighted with a red box. The fields are: 'Name' (BLACK10-AX-PFR400-55), 'Product model number' (PFR400), 'Group' (AXALTA), 'Identification Number' (078742040373), and 'Description' (Black 10, P characteristic, supplier A, 60 pounds). The 'Group' field has a dropdown menu and links for 'Add' and 'Add Subgroup'. The 'Identification Number' field is a text input field. The 'Description' field is a text area.

We have to introduce the number of the barcode manually in the “Identification number” section, in case we want to scan it later with the App. If not, we will have to print a personalized label (part 2).

**Custom Fields**

Weight  
55.0

Chemistry  
Epoxy

Color  
Black

Gloss  
Gloss A

Surface Type  
Surface A

Location  
Rack 2. Level 2A

**Update** Cancel

Once you press "Update" the box will be added to the system.

## Part 2: Print Labels

In case the box doesn't have a barcode or we did the input into the system manually without including the barcode we will need to print a barcode.

- Step 1: Go into the OZOfficeInventory site, click "Items" and then "Inventory". Then select the item or items that need labels.

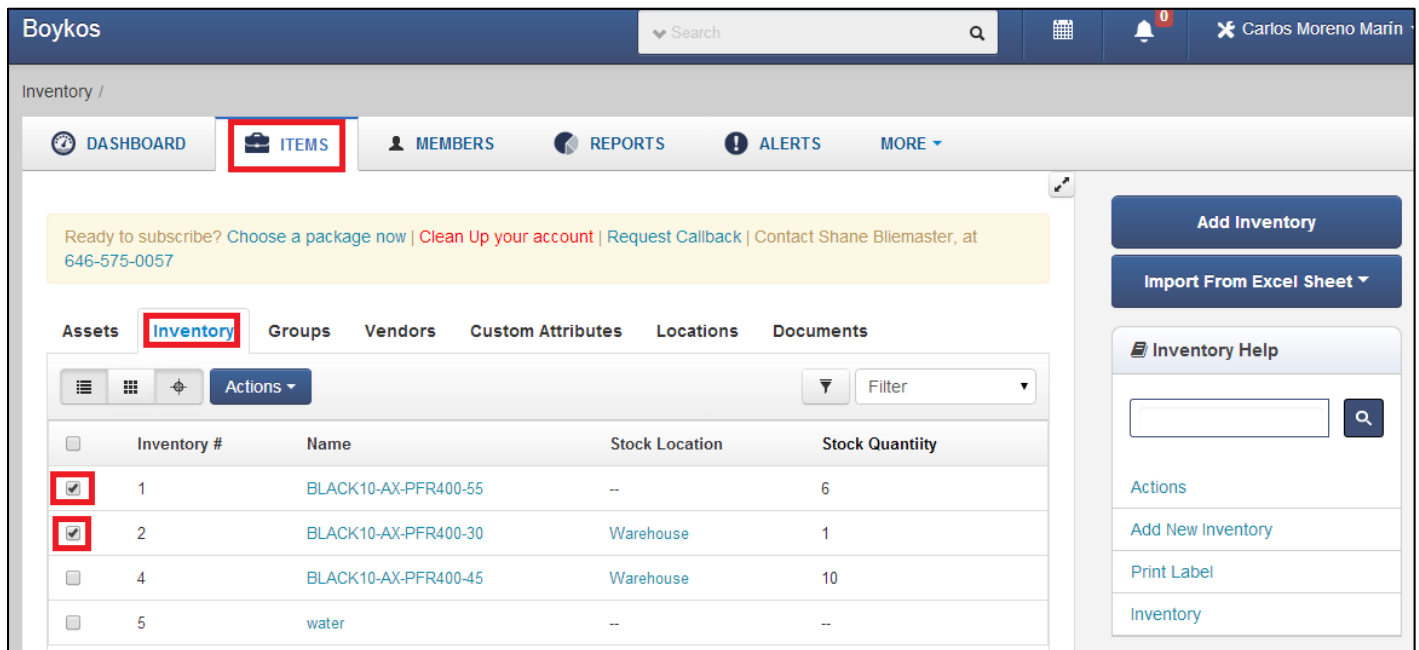

The screenshot shows the Boykos web application interface. The top navigation bar includes 'DASHBOARD', 'ITEMS' (highlighted with a red box), 'MEMBERS', 'REPORTS', 'ALERTS', and 'MORE'. Below the navigation bar, there is a search bar and a user profile for Carlos Moreno Marín. The main content area is titled 'Inventory /' and features a sub-navigation bar with 'Assets', 'Inventory' (highlighted with a red box), 'Groups', 'Vendors', 'Custom Attributes', 'Locations', and 'Documents'. A table of inventory items is displayed with columns for 'Inventory #', 'Name', 'Stock Location', and 'Stock Quantity'. Two items are selected, indicated by red checkmarks in the first column: item 1 (BLACK10-AX-PFR400-55) and item 2 (BLACK10-AX-PFR400-30). To the right of the table, there is an 'Actions' dropdown menu and a 'Filter' dropdown. On the far right, there are buttons for 'Add Inventory' and 'Import From Excel Sheet', and an 'Inventory Help' section with a search bar and a list of actions including 'Print Label'.

- Step 2: Once they are selected, press 'Actions', then 'Print label'.

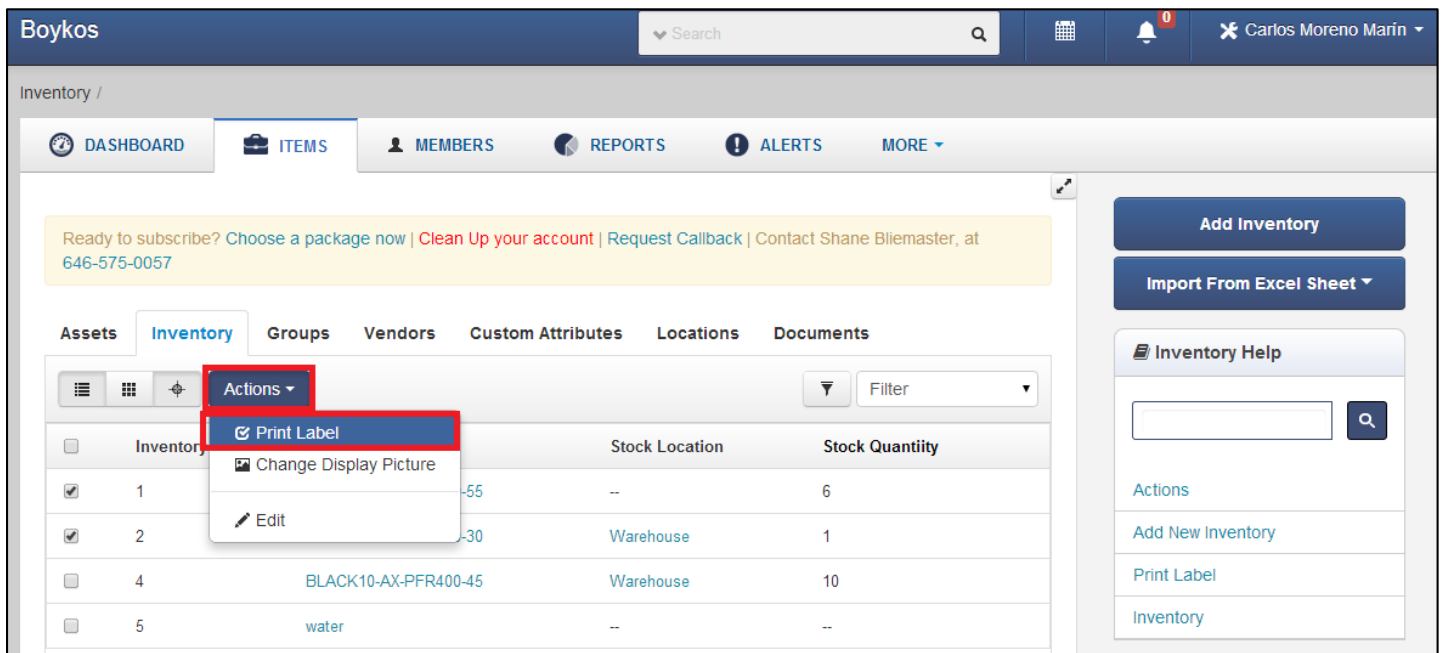

This screenshot shows the same Boykos web application interface as the previous one, but with the 'Actions' dropdown menu open. The 'Print Label' option is highlighted with a red box. The table of inventory items remains the same, with items 1 and 2 selected. The 'Inventory Help' section on the right is also visible, showing the 'Print Label' action in the list.



- Step 3: Select number of copies and then "Print". Be sure that the pop-up blocker is disabled.

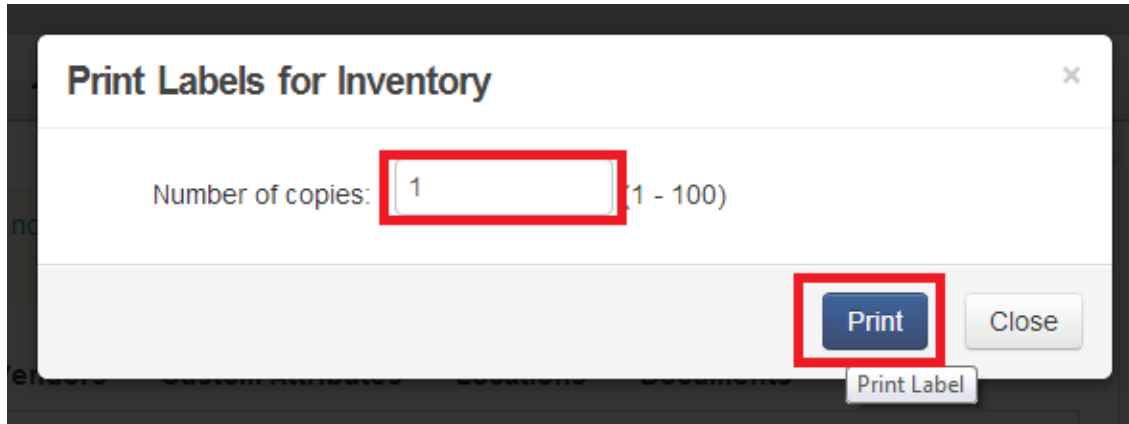

- Step 4: Press Ctrl+P and print the labels. This labels are ready to scan by the mobile phone App.



### Part 3: Remove stock from the system

Operators can easily remove stock with the mobile phone App while they are working. Also, it is possible to remove it from the computer.

#### Mobile phone:

- Step 1: Go into the OZOfficeInventory App, click menu and then “Scan labels”.

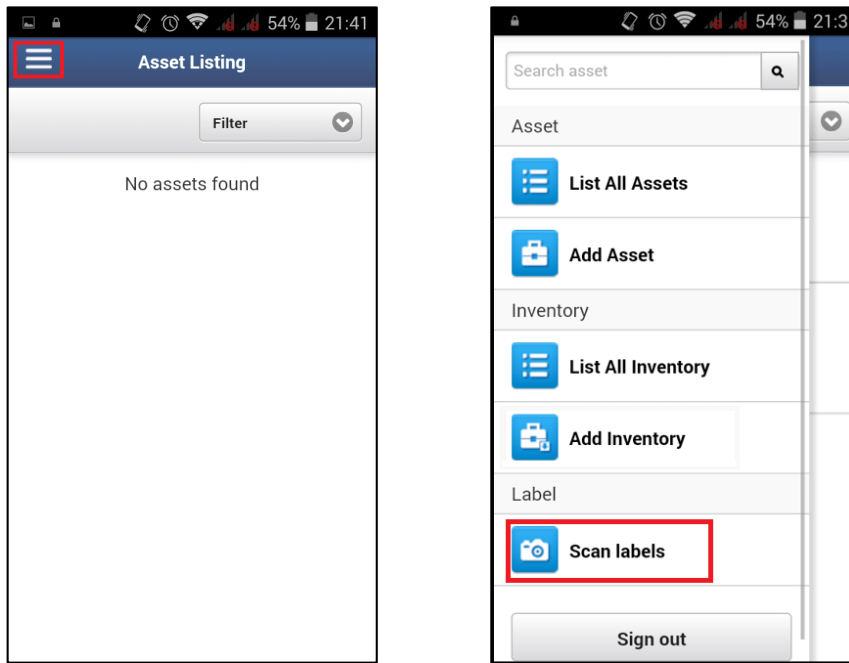

- Step 2: When the label is recognize, click the name. Go down and select “Remove Stock”.

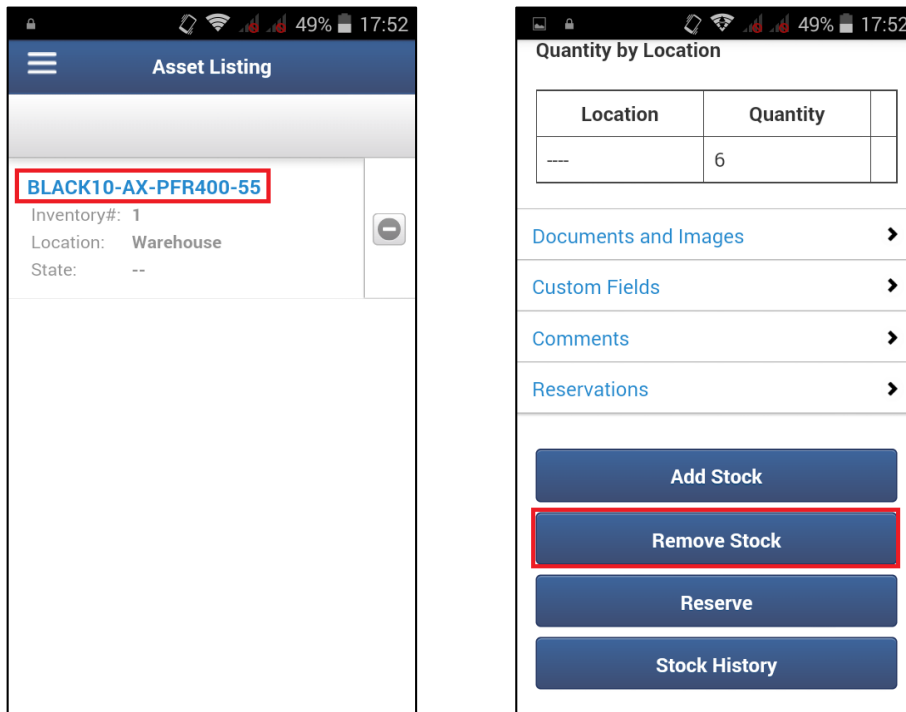

- Step 3: Introduce the quantity to remove, add a comment and then press “Confirm”.

Quantity: 0

Price/Unit: 5,0

Total Price: 0,00

Order by: Carlos Moreno Marín

Comments:

Locations: Select Location

Confirm

**Computer:**

- Step 1: Go into the OZOfficeInventory site, click “Items” and then “Inventory”. Then select the name of the box to remove (we can find it easily if we apply a filter by name).

Boykos

Inventory /

DASHBOARD **ITEMS** MEMBERS REPORTS ALERTS MORE

Ready to subscribe? Choose a package now | Clean Up your account | Request Callback | Contact Shane Bilemaster, at 646-575-0057

Assets **Inventory** Groups Vendors Custom Attributes Locations Documents

Actions Filter

Inventory #	Name	Stock Location	Stock Quantity
<input checked="" type="checkbox"/>	BLACK10-AX-PFR400-55	--	6
<input type="checkbox"/>	BLACK10-AX-PFR400-30	Warehouse	1
<input type="checkbox"/>	BLACK10-AX-PFR400-45	Warehouse	10
<input type="checkbox"/>	water	--	--

Inventory Help

Actions

Add New Inventory

Print Label

Inventory

- Step 2: Once we are in the item, press “Remove Stock”.

The screenshot shows the 'Inventory Details' page for item 'BLACK10-AX-PFR400-55'. The interface includes a navigation bar with 'DASHBOARD', 'ITEMS', 'MEMBERS', 'REPORTS', 'ALERTS', and 'MORE'. A sidebar on the right contains buttons for 'Print Label', 'Add Stock', 'Remove Stock' (highlighted with a red box), 'Reserve', and 'Stock History'. Below these buttons is a 'Recent Scans' section. The main content area displays item information: Inventory# 1, Vendor --, Default Location Warehouse, Total Quantity 6, Group AXALTA, and Remove Stock Price \$5.00. A 'Quantity by Location' table is partially visible at the bottom.

- Step 3: Select the quantity to remove, add a comment and then press “Process Order”.

The 'Remove Stock' modal form contains the following fields and controls:

- Location:** A dropdown menu.
- Quantity \*:** A numeric input field with a spinner, highlighted with a red box. The value is 0. To its right, it says 'Location Total: 6'.
- Price / unit:** A numeric input field with the value 5.0.
- Total Price \*:** A numeric input field with the value 0.00.
- Ordered by:** A dropdown menu showing 'Carlos Moreno Marín (me)'.
- Comments:** A large text area, highlighted with a red box.
- Buttons:** 'Process Order' (highlighted with a red box) and 'Cancel'.

#### Part 4: Add stock to the system (existing material)

We will add stock once we receive new material that is actually in the system. We recommend using the mobile phone App for its simplicity.

##### Mobile phone:

- Step 1: Go into the OZOfficeInventory App, click menu and then “Scan labels”.

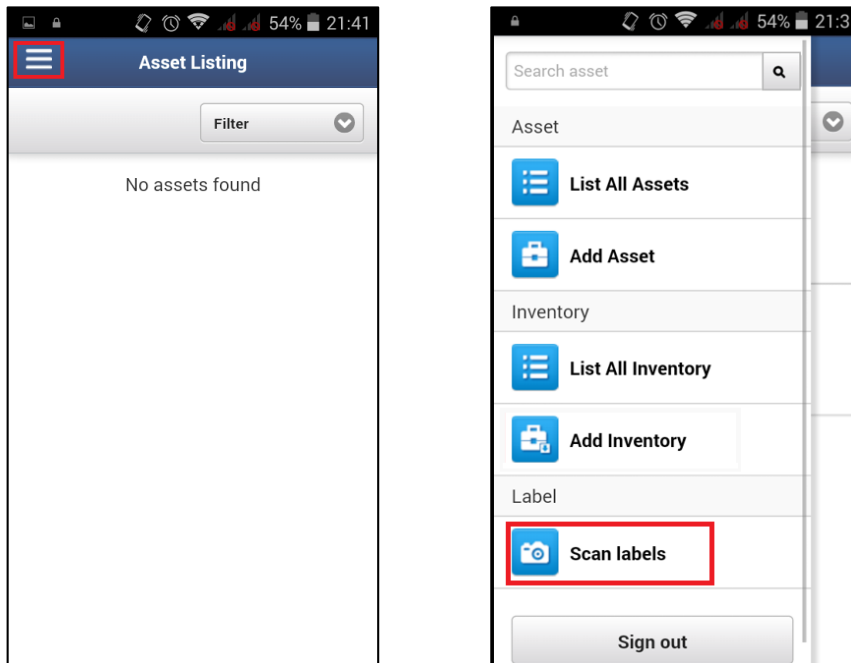

- Step 2: When the label is recognize, click the name. Go down and select “Add Stock”.

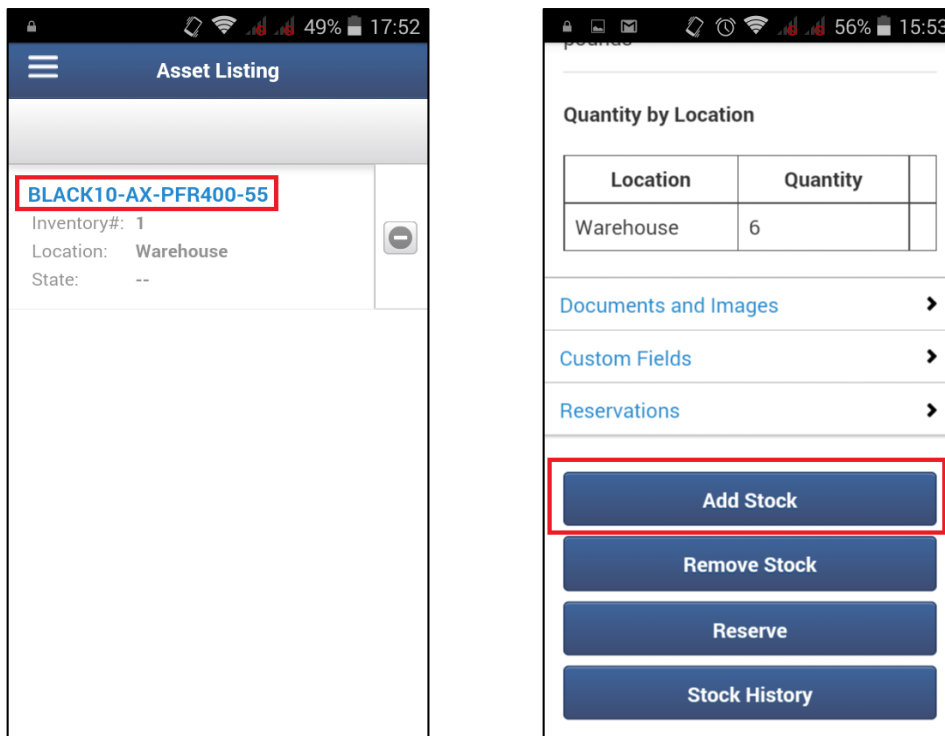

- Step 3: Introduce the quantity to add, add a comment and then press “Confirm”.

**Computer:**

- Step 1: Go into the OZOfficeInventory site, click “Items” and then “Inventory”. Then select the name of the box to add (we can find it easily if we apply a filter by name).

Ready to subscribe? Choose a package now | [Clean Up your account](#) | [Request Callback](#) | [Contact Shane Bilemaster](#), at 646-575-0057

Assets **Inventory** Groups Vendors Custom Attributes Locations Documents

Inventory #	Name	Stock Location	Stock Quantity
<input checked="" type="checkbox"/>	BLACK10-AX-PFR400-55	--	6
<input type="checkbox"/>	BLACK10-AX-PFR400-30	Warehouse	1
<input type="checkbox"/>	BLACK10-AX-PFR400-45	Warehouse	10
<input type="checkbox"/>	water	--	--

- Step 2: Once we are in the item, press “Add Stock”.

The screenshot shows the 'Inventory / Inventory Details' page for item 'BLACK10-AX-PFR400-55'. The page includes a navigation bar with 'DASHBOARD', 'ITEMS', 'MEMBERS', 'REPORTS', 'ALERTS', and 'MORE'. A yellow banner at the top offers subscription options. The item details section shows 'Inventory# 3', 'Vendor --', 'Default Location Warehouse', 'Total Quantity 6', 'Group Axalta', and 'Remove Stock Price \$0.00'. The description is 'Black 10, P characteristic, supplier A, 55 pounds'. On the right side, there are buttons for 'Print Label', 'Add Stock', 'Remove Stock', 'Reserve', and 'Stock History'. The 'Add Stock' button is highlighted with a red box. Below these buttons is a 'Recent Scans' section showing a scan by Maria Dema Fresneda on March 22, 2016.

- Step 3: Select the quantity to add, add a comment and then press “Process Order”.

The screenshot shows the 'Add Stock' modal form. It includes a 'Location' dropdown menu set to 'Warehouse' with a link to 'Add new Location'. The 'Quantity' field is highlighted with a red box and contains the value '0'. To its right, it says 'Location Total: 10'. Below this are fields for 'Price / unit' (0.0), 'Total Price \*' (0.00), and 'Ordered by' (Maria Dema Fresneda (me)). There is a 'Comments' text area. At the bottom, the 'Process Order' button is highlighted with a red box, along with a 'Cancel' button.

## Part 5: Add boxes with remaining powder

Once we finish a job and we have powder coating remaining, it will be stored again. We recommend using a computer since we can clone the original box and change its weight.

Adding a box from the mobile phone will consume too much time compared with cloning it from a computer, since we would have to input all the information that is already in the system again. Also, we will need a computer for printing a new label for this box.

### Computer:

- Step 1: Go into the OZOfficeInventory site, click “Items” and then “Inventory”. Then select the name of the box that is not finished (we can find it easily if we apply a filter by name).

The screenshot displays the OZOfficeInventory web application interface. The top navigation bar includes the user name 'Carlos Moreno Marín' and a search bar. The main navigation menu has 'ITEMS' highlighted. Below the navigation, there are buttons for 'Add Inventory' and 'Import From Excel Sheet'. The 'Inventory' tab is selected, showing a table of inventory items. A filter dropdown is visible above the table, and the item 'BLACK10-AX-PFR400-55' is highlighted in the table. The table has columns for 'Inventory #', 'Name', 'Stock Location', and 'Stock Quantity'.

Inventory #	Name	Stock Location	Stock Quantity
1	BLACK10-AX-PFR400-55	--	6
2	BLACK10-AX-PFR400-30	Warehouse	1
4	BLACK10-AX-PFR400-45	Warehouse	10
5	water	--	--



- Step 2: Once we are in the item, press “Clone”.

Metal Finishing

Inventory / Inventory Details /

DASHBOARD ITEMS MEMBERS REPORTS ALERTS MORE

Ready to subscribe? Choose a package now | Clean Up your account | Request Callback | Contact Eric Thomas, at 512-430-4238

**BLACK10-AX-PFR400-55**  
(Model: PFR400)

Edit Delete **Clone** Retire Inventory

Inventory#	3	Vendor	--
Default Location	Warehouse	Low Stock Threshold (?)	0
Total Quantity	6	Location Threshold (?)	0
Group	Axalta	Add Stock Price	\$0.00
Remove Stock Price	\$0.00		
Description	Black 10, P characteristic, supplier A, 55 pounds		

Print Label  
Add Stock  
Remove Stock  
Reserve  
Stock History

Recent Scans  
Maria Dema Fresneda - March 22, 2016  
More

- Step 3: Change the Name (only the weight part), delete Identification number (we will print a label for this box), change description, add stock quantity (1), change Weight, position and then press “Create Inventory”.

Note: Remember to print a label for this box as explained in part 2.

Metal Finishing

Inventory / New /

DASHBOARD ITEMS MEMBERS REPORTS ALERTS MORE

Ready to subscribe? Choose a package now | Clean Up your account | Request Callback | Contact Eric Thomas, at 512-430-4238

**Create Inventory**

Core Information

Copy Display Image

Name \*

Product model number

Group \*  Add | Add Subgroup

Identification Number

Description

Import From Sheet

New Inventory Help

- Basics
- Mass Import
- Asset Identification Number
- Custom Fields

**Extended Information**

Price For Add Stock   Same Price for Remove Stock

Initial Stock Quantity  (?)

Vendor  Add

Default Location  Add

Location Threshold (?)

Low Stock Threshold (?)

**Custom Fields**

Weight

Chemistry

Color

Gloss

Surface Type

Position

**Number of Clones**

(Maximum number of clones: 25)

**Create Inventory**

Cancel

## Part 6: Save your Inventory in an EXCEL file

If we want to make backup files of our inventory or save it for using the information in another program, OZOfficeInventory has a module for converting the Inventory into an EXCEL file.

- Step 1: Go into the OZOfficeInventory site, click “Reports”. Then select “All inventory” inside Inventory reports.

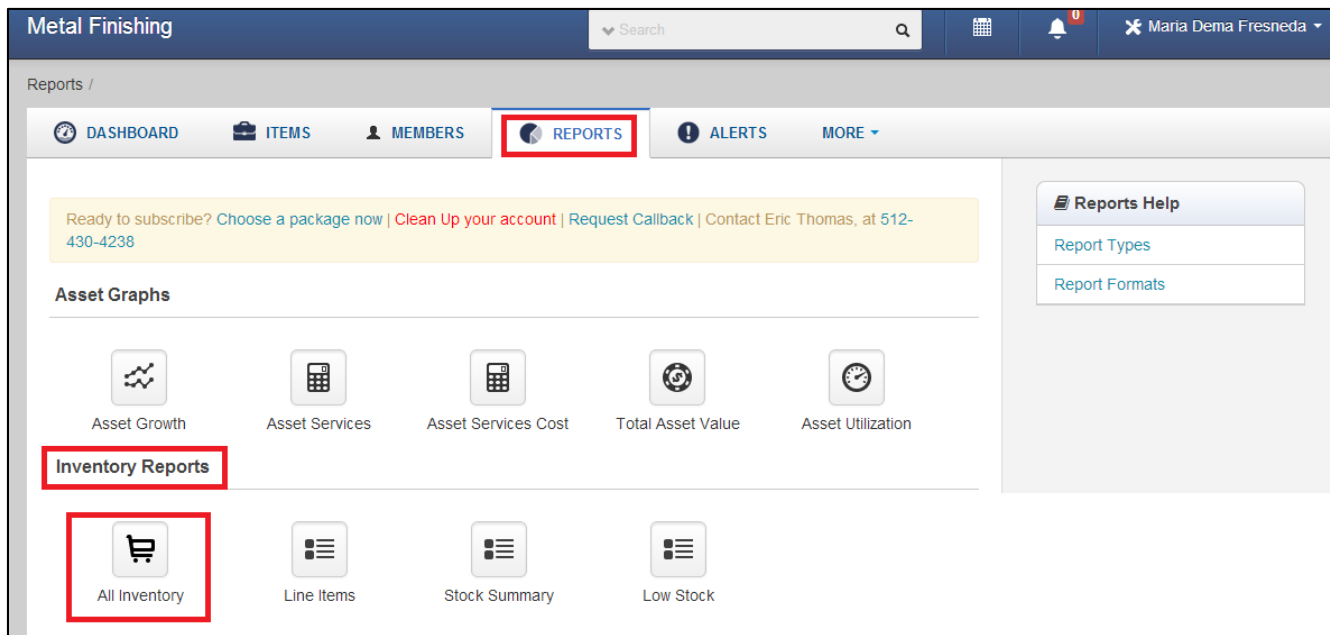

The screenshot shows the 'Reports' section of the OZOfficeInventory application. The top navigation bar includes 'DASHBOARD', 'ITEMS', 'MEMBERS', 'REPORTS' (highlighted), 'ALERTS', and 'MORE'. Below the navigation bar, there is a promotional banner and a 'Reports Help' sidebar with links for 'Report Types' and 'Report Formats'. The main content area is titled 'Asset Graphs' and contains several report icons: 'Asset Growth', 'Asset Services', 'Asset Services Cost', 'Total Asset Value', and 'Asset Utilization'. Below these, the 'Inventory Reports' sub-section is highlighted, containing icons for 'All Inventory' (highlighted), 'Line Items', 'Stock Summary', and 'Low Stock'.

- Step 2: Click “Export” and select “CSV” (that is EXCEL Format).

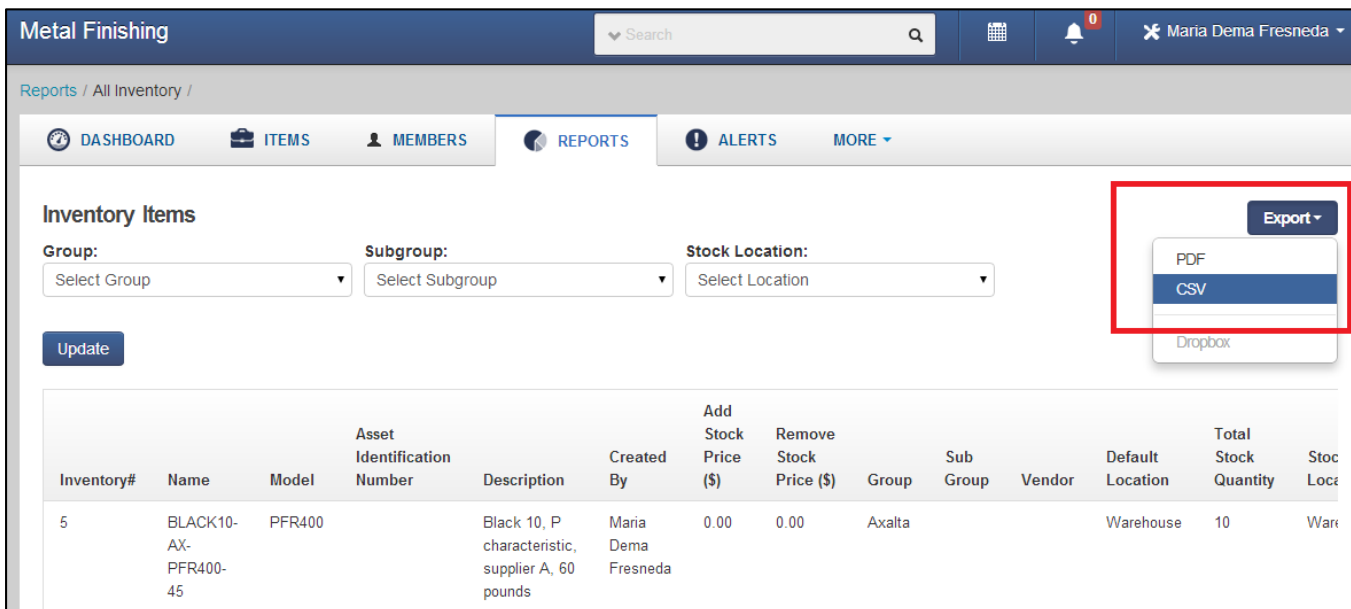

The screenshot shows the 'Inventory Items' page. At the top, there are filters for 'Group', 'Subgroup', and 'Stock Location'. An 'Update' button is located below the filters. On the right side, an 'Export' button is highlighted, and a dropdown menu is open, showing 'PDF', 'CSV' (selected), and 'Dropbox' options. Below the filters and export options is a table with the following data:

Inventory#	Name	Model	Asset Identification Number	Description	Created By	Add Stock Price (\$)	Remove Stock Price (\$)	Group	Sub Group	Vendor	Default Location	Total Stock Quantity	Stoc Loc
5	BLACK10-AX-PFR400-45	PFR400		Black 10, P characteristic, supplier A, 60 pounds	Maria Dema Fresneda	0.00	0.00	Axalta			Warehouse	10	Warr

- Step 3: Open the file and check that it is OK. All the information is stored there.

Inventory\_Items (2).csv - Excel

Inventory#	Name	Model	Asset Id	Desc	Created	B Add	Stock	Remove	S Group	Sub Group	Vendor	Default Lc	Total	Stoc	Stock	Loc	Quantity	Low	Stock	Location	T Weight	Chemistry	Color	Gloss	Surface T	Position
1	BLACK10-/PFR400		Black 10, F	Maria Den		0	0	0	Axalta		Warehouse	Warehouse	2	Warehouse		2	0	0	0	0	55	Epoxy	Black	Gloss A	Surface A	Rack 1R - Level 2B
3	BLACK10-/PFR400		Black 10, F	Maria Den		0	0	0	Axalta		Warehouse	Warehouse	1	Warehouse		1	0	0	0	0	30	Epoxy	Black	Gloss A	Surface A	Rack 1R - Level 2
4	BLACK10-/PFR400		Black 10, F	Maria Den		0	0	0	Axalta		Warehouse	Warehouse	10	Warehouse		10	0	0	0	0	45	Epoxy	Black	Gloss A	Surface A	Rack 1R - Level 2

## Part 7: Import data from an EXCEL file

If we want to import data for setting up our inventory faster or in case we want to recover a backup point, we can do it.

- Step 1: Go into the OZOfficeInventory site, click “Items” and then “Inventory”. Then select “Import from EXCEL sheet” and select “Add New Inventory” if we add it for the first time or “Update existing Inventory” if we want to modify existing inventory.

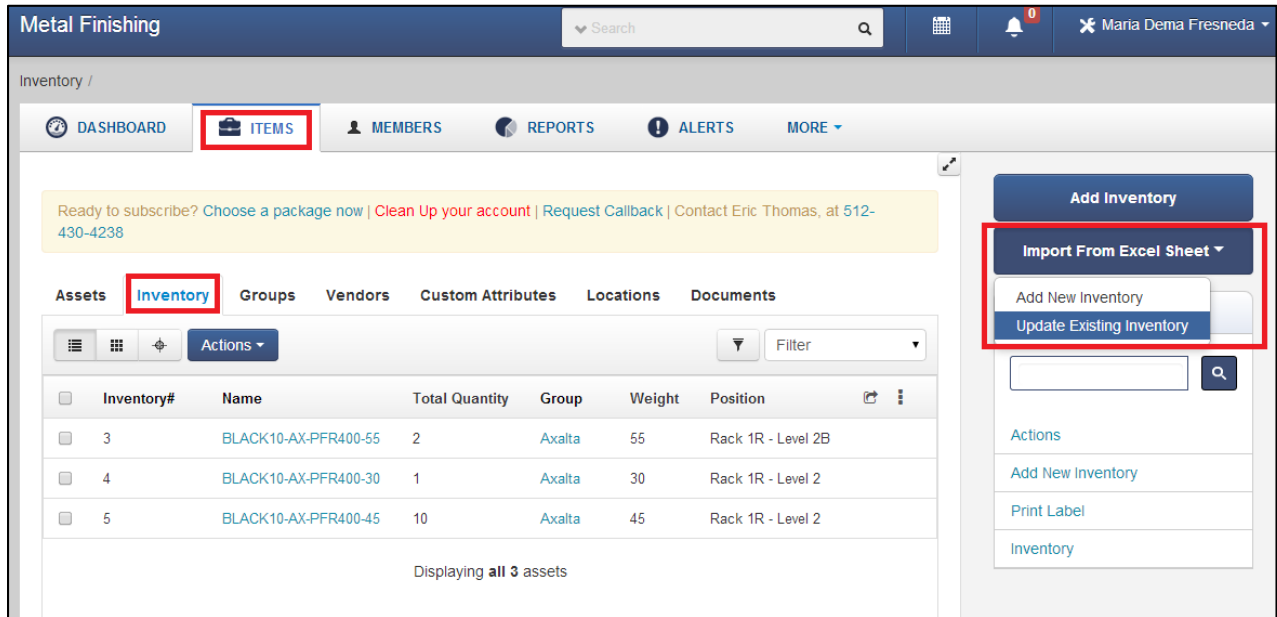

The screenshot shows the 'Inventory' page in the OZOfficeInventory system. The 'ITEMS' menu is highlighted in red. On the right sidebar, the 'Import From Excel Sheet' dropdown is highlighted in red, showing options for 'Add New Inventory' and 'Update Existing Inventory'.

Inventory#	Name	Total Quantity	Group	Weight	Position
3	BLACK10-AX-PFR400-55	2	Axalta	55	Rack 1R - Level 2B
4	BLACK10-AX-PFR400-30	1	Axalta	30	Rack 1R - Level 2
5	BLACK10-AX-PFR400-45	10	Axalta	45	Rack 1R - Level 2

- Step 2: Choose a file from the computer and press “Upload”

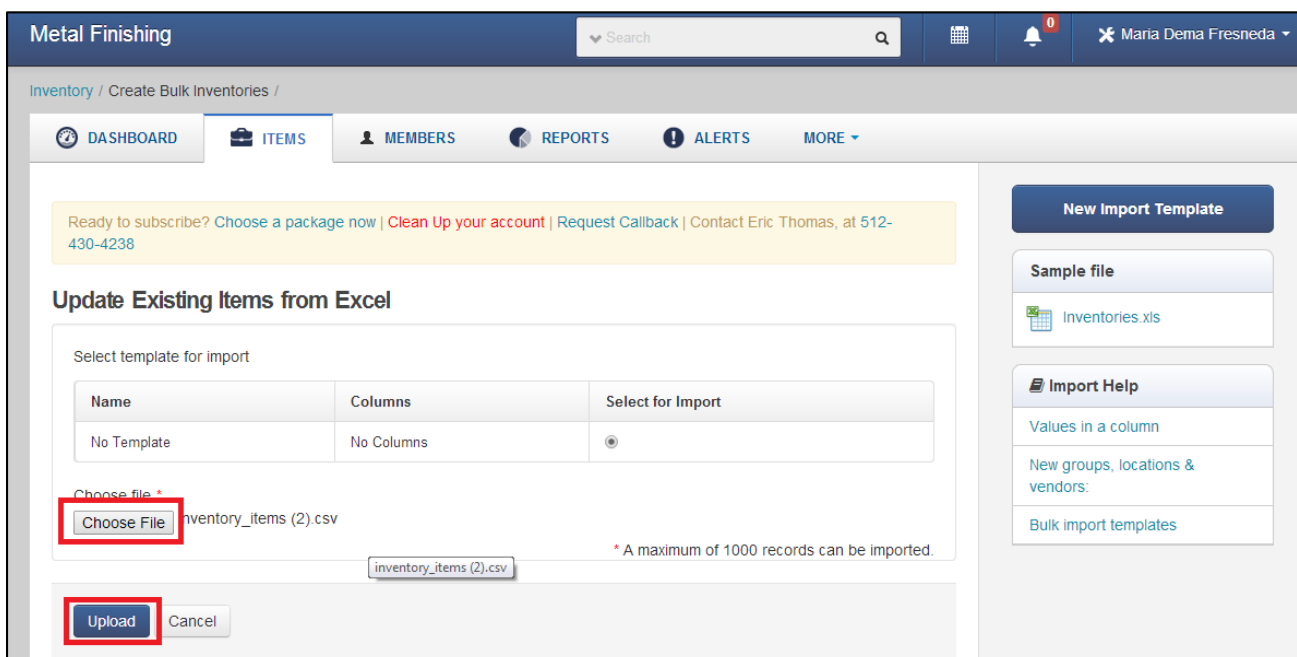

The screenshot shows the 'Update Existing Items from Excel' page. The 'Choose File' button is highlighted in red. The 'Upload' button is also highlighted in red.

Name	Columns	Select for Import
No Template	No Columns	<input type="radio"/>

- Step 3: Assign a value to each column (make sure you press OK before going to the next column). Once finished the mapping of all columns, press “Preview”.

Metal Finishing

Inventory / Create Bulk Inventories / Map Columns

DASHBOARD ITEMS MEMBERS REPORTS ALERTS MORE

Ready to subscribe? Choose a package now | Clean Up your account | Request Callback | Contact Eric Thomas, at 512-430-4238

### Map Columns (Step 1 of 2) for Inventories

Column A Map this Column	Column B unmapped edit   skip	Column C unmapped edit   skip	Column D unmapped edit   skip	Column E unmapped edit   skip
--Select column name--				
"Inventory#"	"Name"	"Model"	"Asset Identification Number"	"Description"
3	BLACK10-AX-PFR400-55	PFR400		Black 10, character A, 55 pounds
4	BLACK10-AX-PFR400-30	PFR400		Black 10, character A, 60 pounds

Ignore header row in Excel  
 If a cell is empty, clear the previous value for it.

If not present, create  
 Group

Preview Cancel

- Step 4: After previewing the inventory to import, press “Import”. Our Inventory is now updated.

Metal Finishing

Inventory / Create Bulk Inventories / Preview

DASHBOARD ITEMS MEMBERS REPORTS ALERTS MORE

Ready to subscribe? Choose a package now | Clean Up your account | Request Callback | Contact Eric Thomas, at 512-430-4238

Preview of file for confirmation

### Assets For Import (Step 2 of 2)

Name	Asset Identification Number
BLACK10-AX-PFR400-55	
BLACK10-AX-PFR400-30	
BLACK10-AX-PFR400-45	

\* This action cannot be undone. Import Cancel

## Part 8: Manage Inputs and Outputs of the system

The system allows us to receive personalized alerts about the use of the inventory. It is also possible to print reports for checking this.

### Check latest alerts:

- Step 1: Go into the OZOfficeInventory site, click “Dashboard”. Scroll down until “Latest Events” appear.

The screenshot displays the 'Metal Finishing' dashboard. At the top, there is a search bar and a user profile for 'Maria Dema Fresneda'. Below the header, navigation tabs include 'DASHBOARD', 'ITEMS', 'MEMBERS', 'REPORTS', 'ALERTS', and 'MORE'. A yellow banner at the top left contains subscription and account management links. A 'Did you know?' tip box explains the use of filters. Three summary cards show '0 assets are overdue', '0 assets are due today', and '0 reservations start today'. The 'Latest Events' section lists recent actions such as 'sold', 'edited', and 'added asset' with timestamps. A 'Dashboard Help' sidebar on the right offers a search bar and links to '90 Seconds Overview', 'Getting Started Guide', 'Requests', 'Events', and 'Subscribe'.

## Receive alerts via email:

- Step 1: Go into the OZOfficeInventory site, click “Alerts”. Choose between the different options available and then press “Save settings”. We can receive an email for every single event or a daily email with all the alerts.

The screenshot shows the 'Alerts' settings page in the OZOfficeInventory system. The page title is 'Metal Finishing'. The navigation bar includes 'DASHBOARD', 'ITEMS', 'MEMBERS', 'REPORTS', 'ALERTS' (highlighted with a red box), and 'MORE'. A search bar and a user profile 'Maria Dema Fresneda' are also visible. A yellow banner at the top of the main content area contains links: 'Ready to subscribe? Choose a package now | Clean Up your account | Request Callback | Contact Eric Thomas, at 512-430-4238'. The 'Alerts Settings' section is titled 'Select Email Format' and has three radio button options: 'Email for each subscribed event' (selected), 'Daily digest of alerts', and 'Subscribe to Newsletter'. Below this is the 'Actions that generate Emails' section with a list of checkboxes: 'Checkin', 'Checkout', 'Extend Checkout', 'Request for Checkin', 'Request Reservation', 'Stock Request', 'Reservations starting today', 'Overdue', 'Email Print Labels', 'Activation of an Asset from Retired State', 'Retiring of an Asset', and 'Deletion of an Asset'. At the bottom, there are two buttons: 'Save Settings' (highlighted with a red box) and 'Cancel'.



## Print Reports:

- Step 1: Go into the OZOfficeInventory site, click “Reports”. Then select “Stock Summary” inside Inventory reports.

The screenshot shows the 'Metal Finishing' dashboard. The top navigation bar includes 'DASHBOARD', 'ITEMS', 'MEMBERS', 'REPORTS' (highlighted with a red box), 'ALERTS', and 'MORE'. Below the navigation bar, there is a yellow banner with subscription information. The main content area is titled 'Asset Graphs' and contains several icons: 'Asset Growth', 'Asset Services', 'Asset Services Cost', 'Total Asset Value', and 'Asset Utilization'. Below this, there is a section for 'Inventory Reports' with icons for 'All Inventory', 'Line Items', 'Stock Summary' (highlighted with a red box), and 'Low Stock'. On the right side, there is a 'Reports Help' sidebar with links for 'Report Types' and 'Report Formats'.

- Step 2: Select the date for the report, choose a group or location if you want your report to be more specific, then press “Export”, “PDF”.

The screenshot shows the 'Stock Summary' configuration page. The top navigation bar is the same as in the previous screenshot. The main content area is titled 'Stock Summary' and contains several form fields: 'Location:' (Select Location), 'Group:' (Select Group), and 'Subgroup:' (Select Subgroup). Below these, there is a section for 'Action Date' with 'From:' (03/15/2016) and 'To:' (03/22/2016) fields, both highlighted with a red box. Below the date fields, there are 'Action:' (All) and 'Ordered For:' (Select User) dropdown menus. At the bottom left, there is an 'Update' button. On the right side, there is an 'Export' dropdown menu (highlighted with a red box) with options for 'PDF', 'CSV', and 'Dropbox'.

- Step 3: Take a look at the added and removed stock.

Inven tory#	Name	Mod el	Asset Identification Number	Gro up	Sub Group	Loca tion	Quanti ty Sold	Total Remove Stock Price	Quantit y Added	Total Add Stock Cost	Quantity On From Date	Quantity On To Date	Net Quantity
3	BLACK10-AX-PFR400-55	PFR 400		Axa lta		Ware house	4	0.0	6	0.0	0	2	2
4	BLACK10-AX-PFR400-30	PFR 400		Axa lta		Ware house	0	0.0	1	0.0	0	1	1
5	BLACK10-AX-PFR400-45	PFR 400		Axa lta		Ware house	0	0.0	10	0.0	0	10	10

## 6.2. Appendix 2. WASP Inventory Control 7 User Manual

### Overview

	STANDARD	PROFESSIONAL	ENTERPRISE
Technical Support	Lifetime	Lifetime	Lifetime
PC client licenses	1	5	Unlimited
Mobile licenses	1	1	5
Management reports	60+	80+	80+
Update inventory in real-time	✗	☑	☑
PC network supported	✗	☑	☑
Unit breakdowns	✗	☑	☑
Pick order request & tracking	✗	☑	☑
Purchase orders	✗	☑	☑
Custom PO #'s & pick order #'s	✗	☑	☑
Full receiving functionality	✗	☑	☑
Manage multiple suppliers	✗	☑	☑
Track non-inventory items	✗	☑	☑
Assembly / disassembly	✗	☑	☑
Kitting	✗	☑	☑
Microsoft SQL server compatible*	✗	✗	☑
	FREE LIVE DEMO	FREE LIVE DEMO	FREE LIVE DEMO

#### WASP Inventory Control 7 Versions

WASP Inventory Control 7 is a software developed by Wedge Advanced Software Product who mission statement is “To desire to provide straightforward, error-free tracking methods that make our customers’ lives easier”. WASP Inventory Control 7 delivers a platform that is fairly priced, easily implemented and ready-to-use after installation. WASP Inventory Control 7 offers 3 different version of inventory control, Standard, Professional and Enterprise. With each version offering more features to help with customer’s inventory needs.

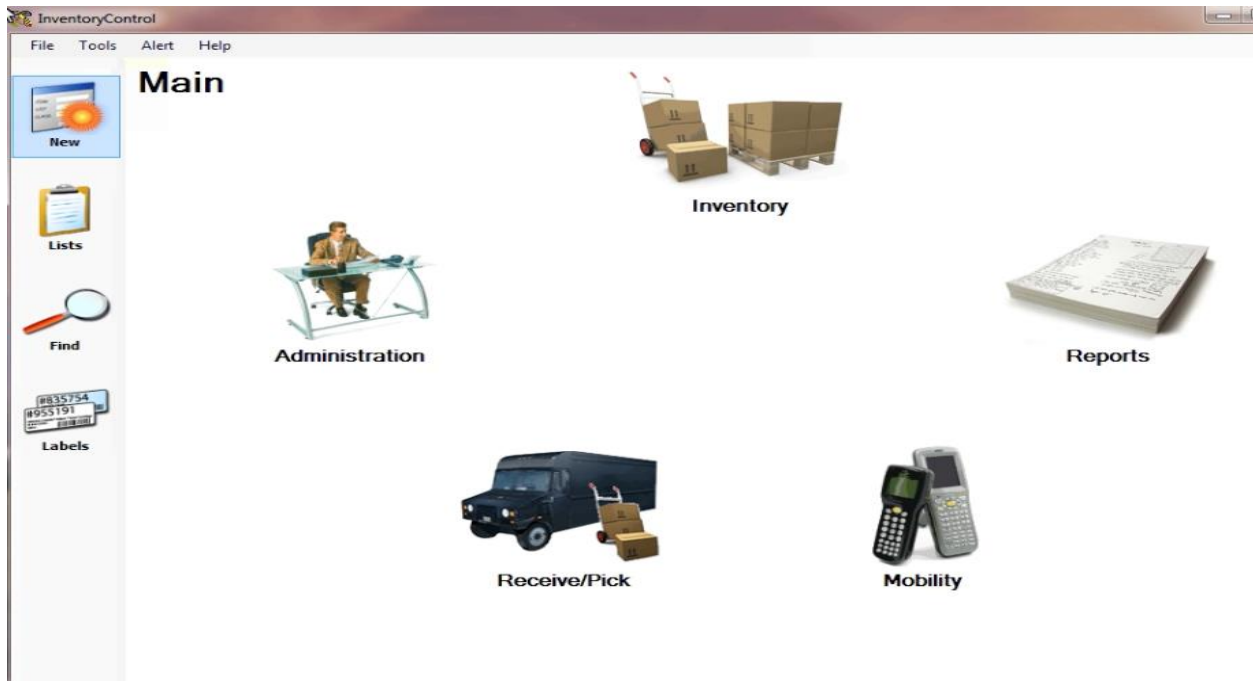

Inventory Control 7 Main Menu

Throughout this section of the report we will be reviewing our experiences trialing Inventory Control 7 Standard version, Key features of the software that gives Boyko inventory control solutions and implementation of the software.

WASP Inventory Control Software has a very simple interface, with each inventory tool located at the main menu, satisfying your inventory need is a quick click away. Inventory Control 7 has 5 main features, Administration, Inventory, Reports, Remove/Pick and Mobility. Each feature directs you to its main page where you can customize fields to meet your inventory needs. For example, Administration; you can set preferences to allow which employee or groups has access to administration privileges and or features of inventory control 7. This feature will be very useful within Boyko's because (1) it will reduce the chances of employees inputting the wrong data in

the wrong fields, (2) it will help with the implementation process with employees, as you can gradually add responsibilities to employees.

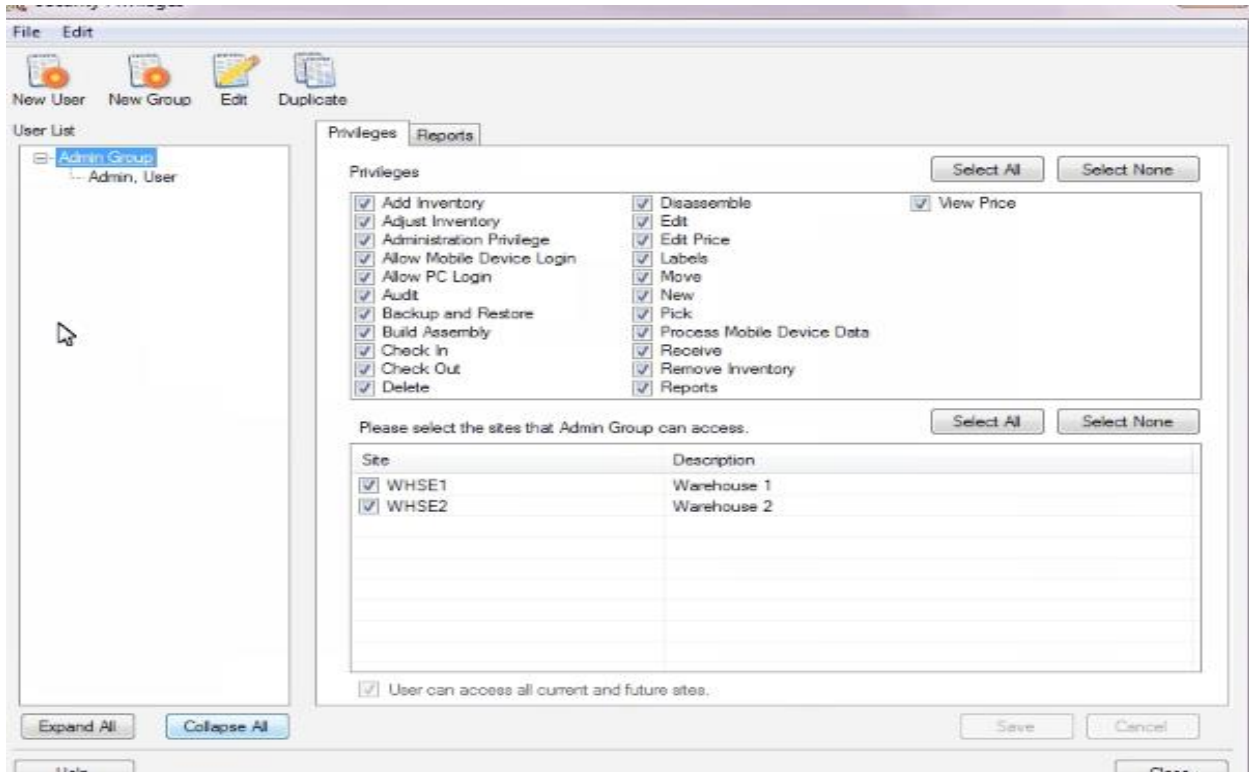

Admin setting page

After setting up your administration privileges, you can then begin to add your variables of inventory control. WASP Inventory control makes adding your variables very simple. The first steps you will take are: (1) Click the New Icon on the top left side of the main menu, which will direct you the definition page. Within this page you can now define Inventory, Inventory site, location within inventory site, max and min stock levels, holding and selling cost, reorder quantity and much more. This tool in Inventory Control 7 allows you to make defining Inventory very detailed or simple. Using this feature within Boyko's Inventory control will give managers the freedom to customize how they want inventory to be defined and tracked.

The screenshot shows the 'Create New Item' dialog box with the 'General' tab selected. The 'Item Number' field contains '4965844'. The 'Type' dropdown is set to 'Inventory'. The 'Cost Method' dropdown is set to 'Moving Average'. The 'Tax Code' dropdown is set to 'Tax'. There are several empty text boxes for 'Description', 'Checkout Length', 'Manufacturer', 'List Price', 'Average Cost', 'Min Stock Level', 'Reorder Qty', and 'Cost'. There are also several unchecked checkboxes for tracking options and user requirements.

### Create New Item General Tab

Inventory Control 7 also give you the freedom to be as precise as possible with your location information of your inventory. Under the Location Setting tab you can create a precedence of locations, with your primary as your main location. After choosing your primary you can either be very simple or very detailed with your inventory. For example, after selecting primary location you can then add a site which will be the location of all inventory that is in holding. If you wanted to be more detailed you can then add a location to the site, for example, racks or pallets. Using the features, we will be able to assign Boyko's paint inventory to their designated rack row, with custom parameters.

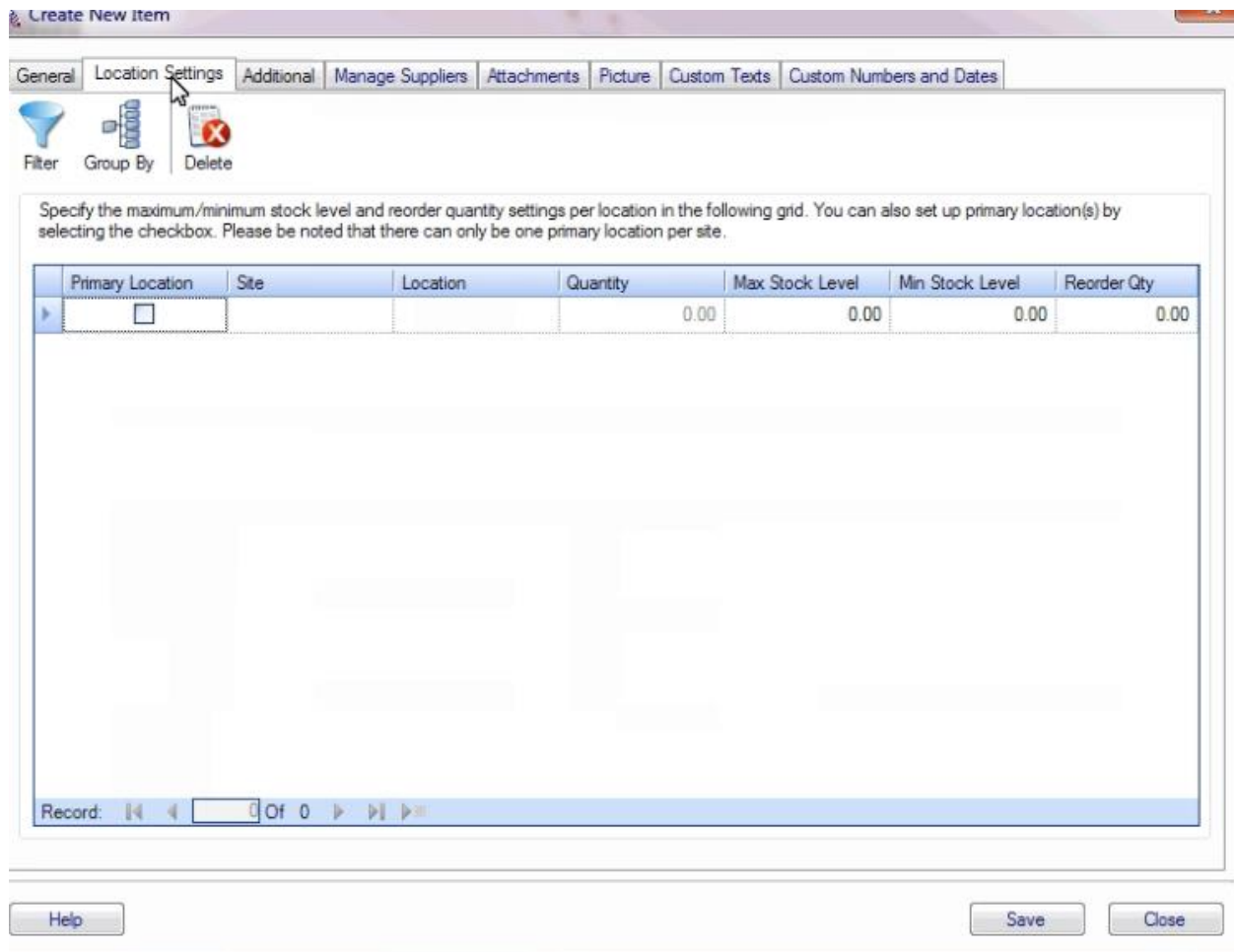

### Location Setting Tab

After creating your Items in Inventory and your location preferences, you are now able to add specific quantities to your inventory. To access this feature, go to main menu and click inventory. At the bottle of main menu, you will have 9 inventory tools; add inventory, remove inventory, move inventory, check in, check out, adjust, assemble, disassemble and begin audit. We will be using 2 of the inventory tools (add, remove inventory) for our project.



Inventory tool menu



## Boyko's Implementation of WASP

Below are the following steps to add a new box of powder coating paint to WASP.

The screenshot shows the 'Edit Item - 1000 : AXALTA RED' window. The 'General' tab is active, showing the following fields and values:

- Item Number: 1000
- Description: AXALTA RED
- Manufacturer: AXALTA
- Item To Be Tracked By:  Lot,  REMAINING WEIGHT,  Pallet
- Require the user to fill out:  Weight of Box,  Supplier,  Customer
- Cost: 0.00, Cost Method: Moving Average
- List Price: 0.00, Average Cost: 0.00
- Sale Price: 0.00, Min Stock Level: 5.00
- Max Stock Level: 20.00, Reorder Qty: 15.00
- Tax Code: Tax
- Total Available: 40.00, Total Checked-Out: 0.00, Total In-House: 40.00

- 1) Access “New” from main menu and click item
- 2) Create Unique “Item Number” for paint
- 3) Create Description then manufacturer
- 4) Select “Lot” for the field “Item to be tracked by”
  - a. We are using “Lot” because we do not want to log in a large quantity of the same boxes.
  - b. Using “Lot” allows us to add/remove multiple boxes that are the same, without scanning each box one-by-one.
  - c. This feature is very useful since there isn't a standard number of boxes used per job, therefore employees will add/remove a batched number of boxes from the lot and manually enter how many boxes are being added or removed.
- 5) Select “Customer” to require the user to fill out which customer job is the paint being use for.
- 6) Select your Max, Min and reorder stock levels.
- 7) Go to Location Setting Tab

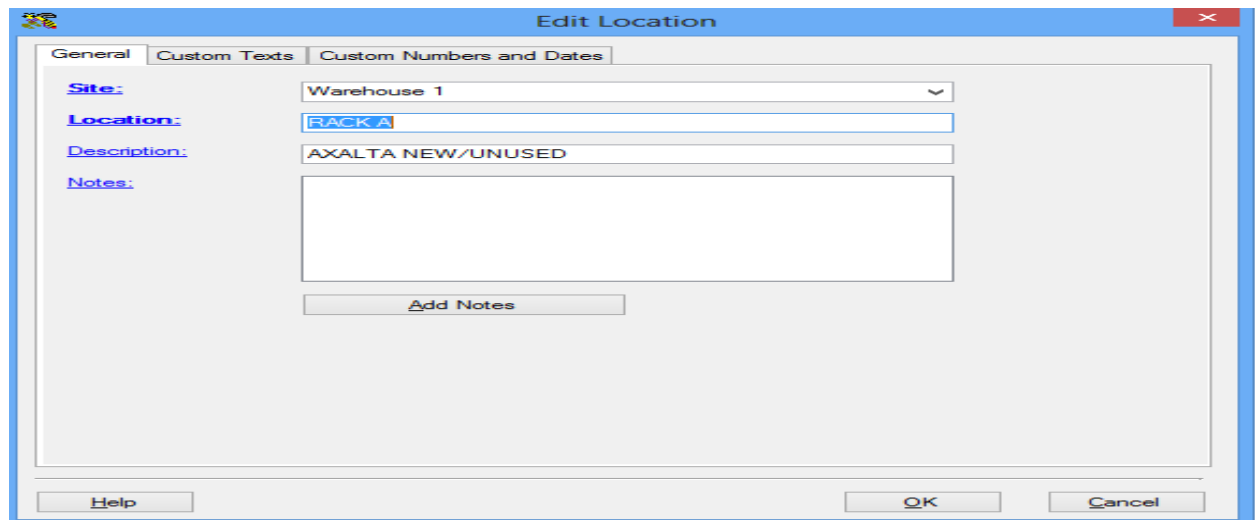
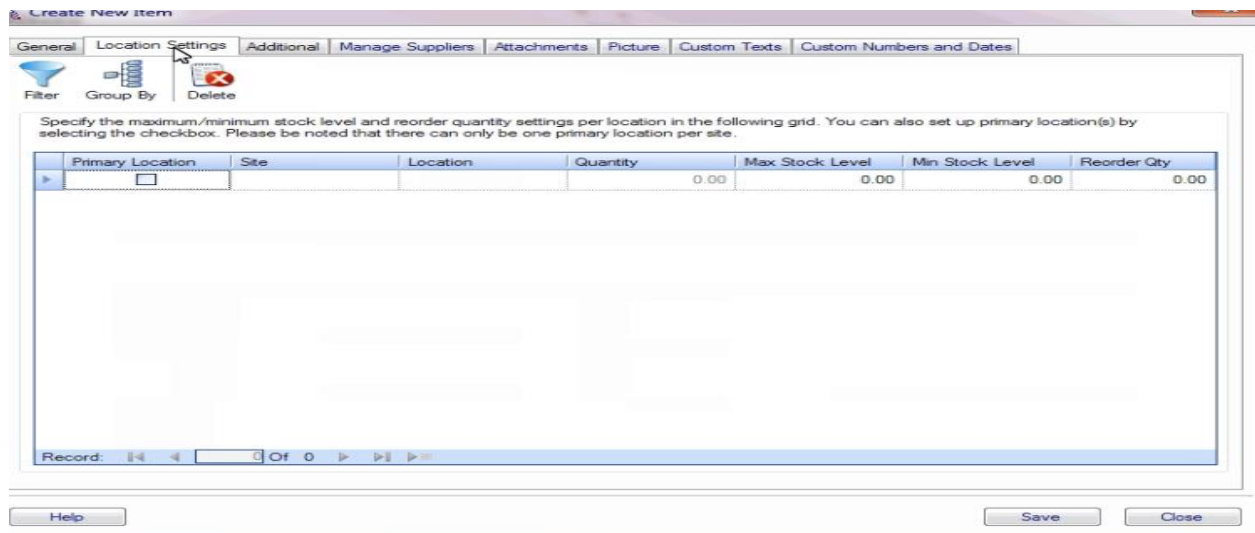

- 1) Select primary location
  - I. This location is where all inventory needs is stored
- 2) Click On Site Field
  - I. Fill out data request
  - II. Site: The Location of your Primary Location
  - III. Location: Where the Item in location within the site
  - IV. Description: A brief description of the item that is being housed at the location
  - V. Click OK

VI. Set you maximum, minimum and reorder quantity for your site location.

Specify the maximum/minimum stock level and reorder quantity settings per location in the following grid. You can also set up primary location(s) by selecting the checkbox. Please be noted that there can only be one primary location per site.

Primary Location	Site	Location	Quantity	Max Stock Level	Min Stock Level	Reorder Qty
<input checked="" type="checkbox"/>	Warehouse 1	Rack A	40.00	20.00	5.00	15.00
*						

Record: 1 Of 1

- After completing the required fields under the Location setting, you will then be able to view current quantity, maximum and minimum stock level and reorder quantity.
- If done correctly, you are now able to add/remove inventory
- Go back to the main menu and click on inventory.
- Click on Add



- 1) Go back to the main menu and click Inventory
- 2) Click Add Inventory

I. WASP will be directed to the Inventory Page

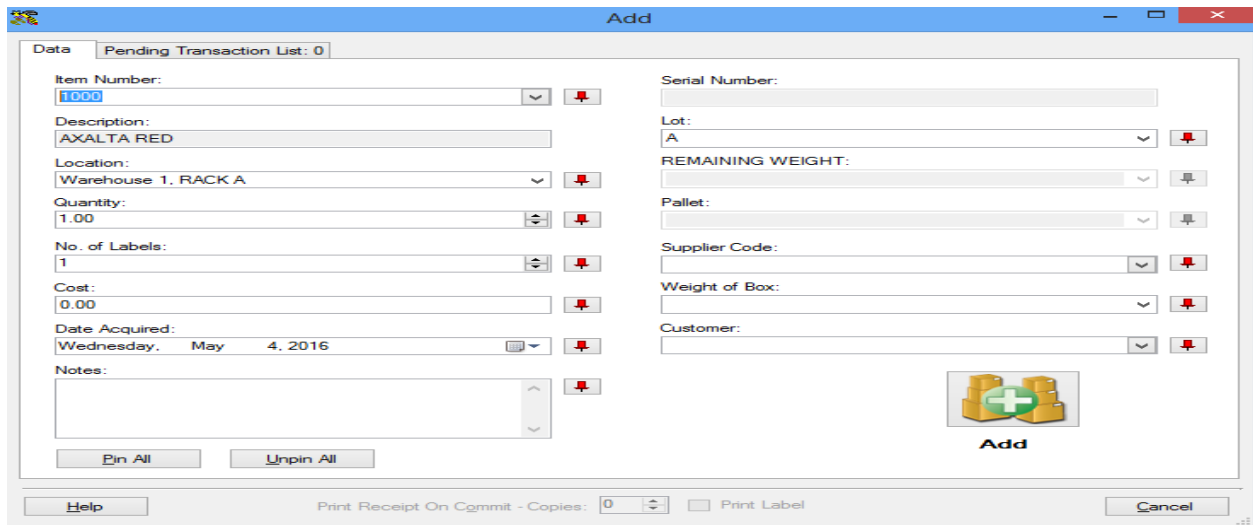

- 1) Fill out Fields for Adding Inventory

- I. Item Number: Unique Number we created when creating a new item of inventory.
- II. Description: Brief description of the item that we are adding to inventory
- III. Location: Exact location of item

- 2) Select Quantity of Inventory we are adding
  - I. Note, since we recommended “lot” tracking, we can add a huge quantity of items at once to the lot instead of adding one-by-one (serial)
  - II. Define “LOT”, We recommend assign each “Lot” with it respected rack
- 3) Number of Labels
  - I. We recommend printing labels for the rack when adding Inventory.
  - II. Each rack will be in respect to it Lot, therefore (1) label is needed. For Example
    - a) Warehouse 1-RackA is designated for AXALTA RED
    - b) RackA will receive the Label, detailing the Item Number, Description and Lot
- 4) Click Add, then commit to the inventory
  - I. You can review pending transaction in the pending transaction list tab if you want to review before committing

Below are the steps to removing Inventory



- 1) Go back to the main menu and click Inventory
- 2) Click Remove Inventory
  - I. WASP will be directed to the Inventory Page

1) Fill out Fields for Removing Inventory

- I. Item Number: Unique Number we created when creating a new item of inventory.
- II. Description: Brief description of the item that we are adding to inventory
- III. Location: Exact location of item

2) Select Quantity of Inventory we are Removing

- I. Note, since we recommended “lot” tracking, we can remove a huge quantity of items at once from the lot instead of removing one-by-one
- II. Select which Lot we will be removing items from.

3) Select which customer the items in inventory are being applied to

4) Click remove, then commit to the inventory

- I. You can review pending transaction in the pending transaction list tab if you want to review before committing

Below are the steps to view what you have in Inventory

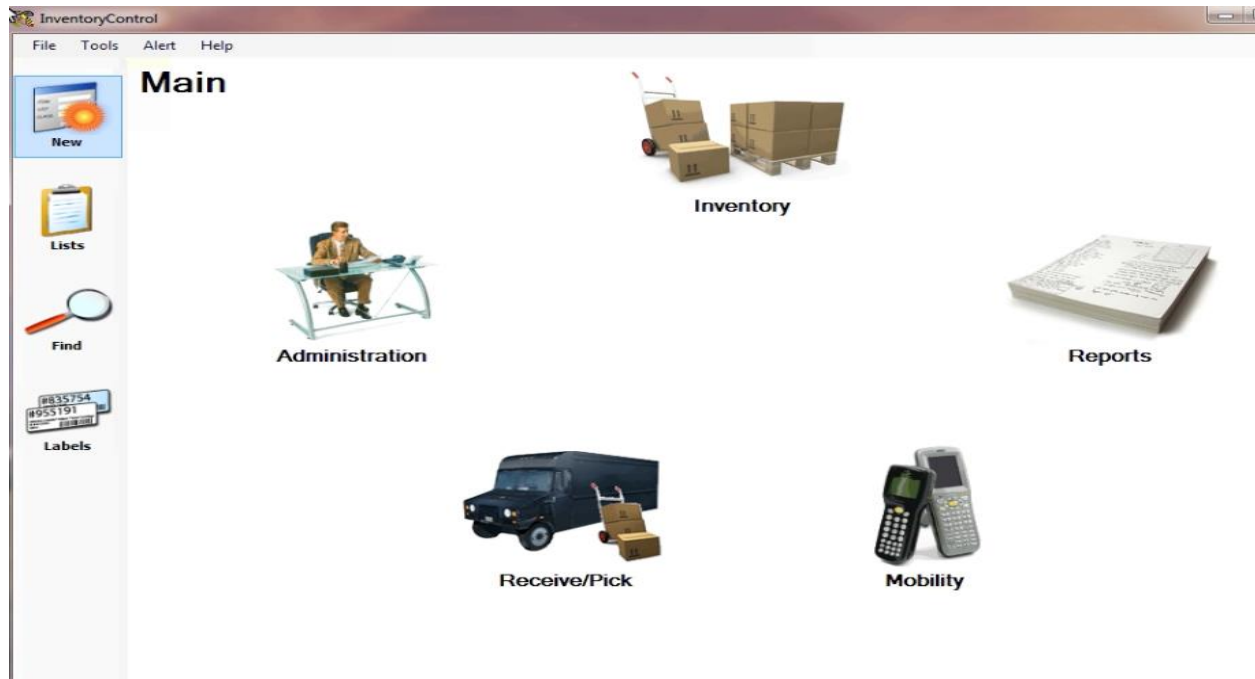

1) From the main menu click on list

- I. The list feature allows you to view the following variables in WASP inventory Control
  - i. Customer
  - ii. Manufacturer
  - iii. Item
  - iv. Location
  - v. Site
  - vi. Supplier
  - vii. Inventory

Inventory List

Filter Toggle Check In Check Out Move Add Remove Print Export To File Group By Hidden Columns Views

View inventory list with all the trackbys

Item Description	Site	Location	Quantity	Oldest Date Acq...	Latest Date Acq...	Pallet	Lot	Weight of Box
AXALTA RED	Warehouse 1	WALL	40.00	5/4/2016	5/4/2016		A	
AXALTA RED U...	Warehouse 1	WALL	1.00	5/4/2016	5/4/2016			10
AXALTA RED U...	Warehouse 1	WALL	1.00	5/4/2016	5/4/2016			10
AXALTA RED U...	Warehouse 1	WALL	1.00	5/4/2016	5/4/2016			30

Record: 1 Of 4

Search Close

- 1) From the main menu click List
- 2) Click Inventory, you will be navigated to the Inventory List Page
- 3) Select item you want to see view in Inventory



**6.3. Appendix 3. Small racks.**



**6.4. Appendix 4. Large Rack**

