

Creación de la marca, manual de identidad corporativa y mobiliario para SenSa restobar.

Marta Marín Porriño

Tutora: María Begoña Jordá Albiñana
Ingeniería en Diseño Industrial
y Desarrollo de Productos
Julio 2017

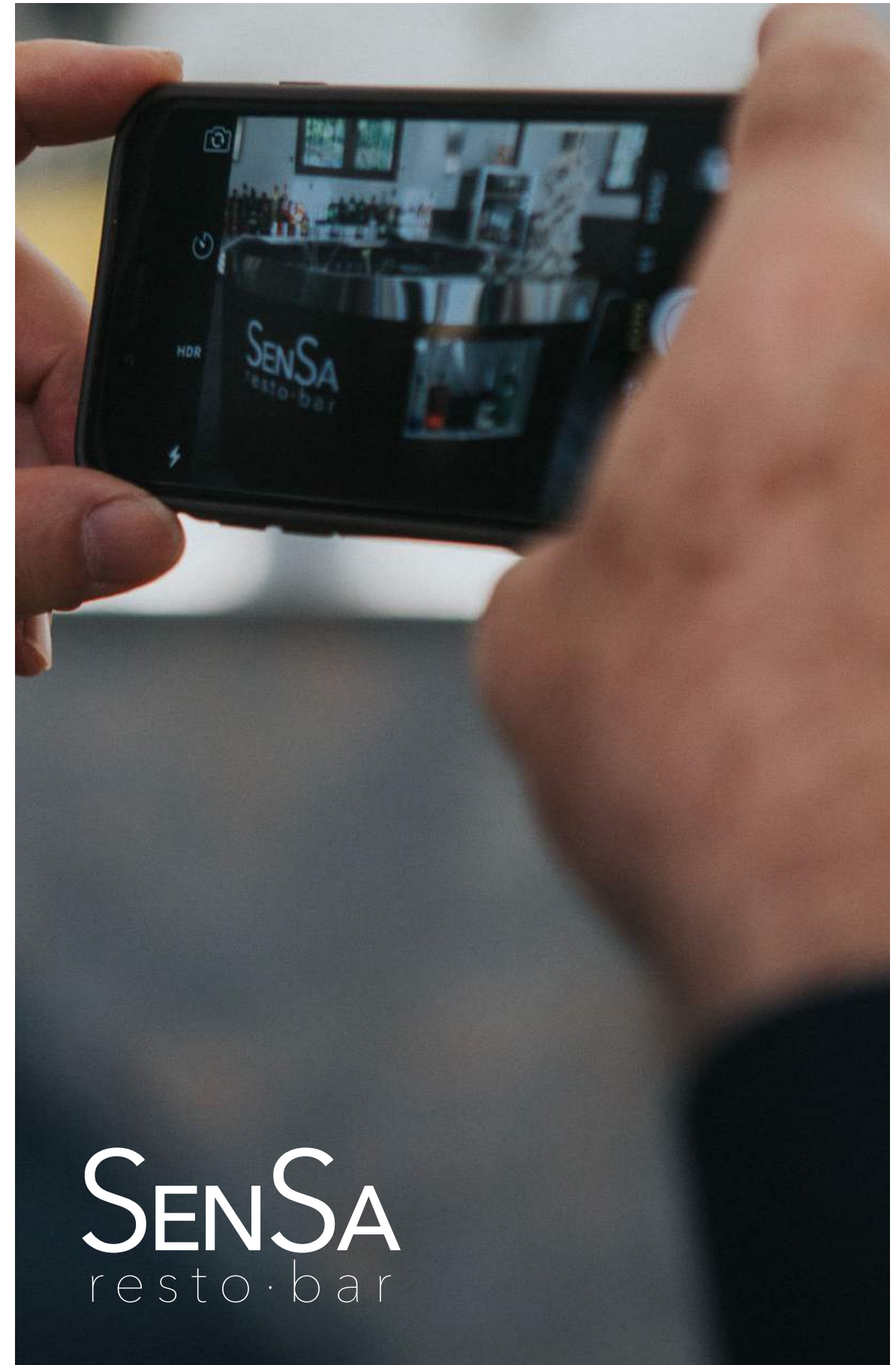

Justificación selección

CREACIÓN DE LA MARCA

MANUAL IDENTIDAD CORPORATIVA

DISEÑO MUEBLE PARA COCTELERÍA

Índice

objetivos

creación de la marca

antecedentes

diseño de la marca

moodboard

primeras ideas/ordenador

propuesta final

manual de identidad corporativa

elementos básicos/normas

colores corporativos

espacio de respeto

tipografía corporativa

usos incorrectos

aplicaciones

tarjeta

cartas

carteles

banderola

diseño web

mobiliario

condiciones de encargo

antecedentes

alternativas

criterios de selección

solución adaptada

explosionado

medidas

materiales

montaje

producto final

presupuesto

conclusiones

Creación de la marca
antecedentes



Creación de la marca
diseño de la marca
moodboard

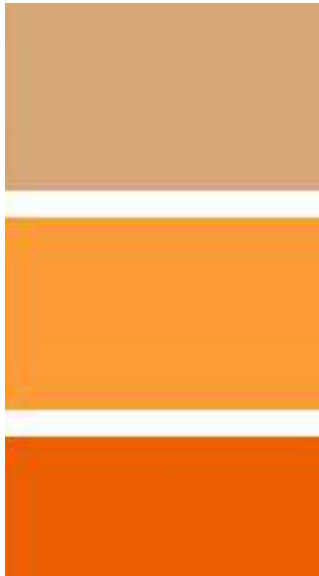

Creación de la marca
diseño de la marca
primeras ideas/ordenador



Creación de la marca
diseño de la marca
propuesta final



SENSA
resto · bar

Manual de identidad corporativa
elementos básicos/normas
colores corporativos
espacio de respeto
tipografía corporativa
usos incorrectos

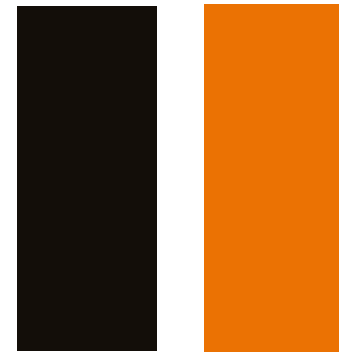

SENSA
resto · bar

Tipografía logotipo: AvenirNext

Tipografía auxiliar: Brandon Grotesque

SENSA
resto · bar

SENSA
resto · bar

Manual de identidad corporativa

- aplicaciones
- tarjeta
- cartas
- carteles
- banderola
- diseño web

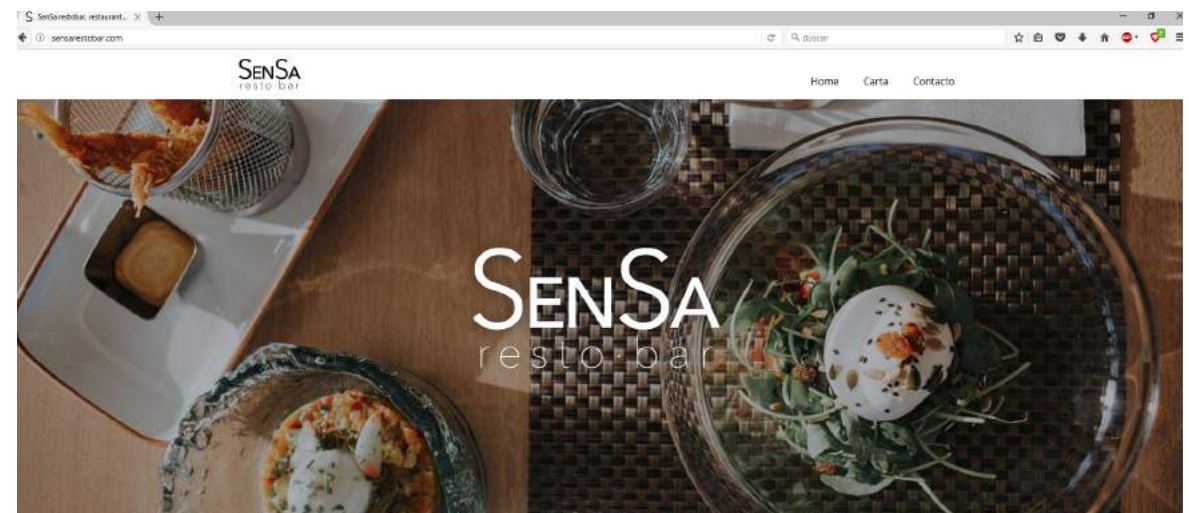

SENSA RESTOBAR

SANTOS Y SABORES

Sensa restobar es un restaurante localizado en uno de los lugares más destacados de Elche, el Paseo de la Estación. Su cocina combina la tradición con un estilo casual, provocando que el comensal experimente, gracias a sus sentidos, las mejores sensaciones culinarias y disfrute de los auténticos sabores de sus productos, en un ambiente céntrico y tranquilo, perfecto para cualquier hora del día.



Mobiliario
condiciones de encargo

mueble para coctelería

estilo casual

coherencia *branding* e interiorismo

target group 25-35 años

funcional

higiénico

**Mobiliario
antecedentes**



**Mobiliario
alternativas**



alternativa 1



alternativa 2

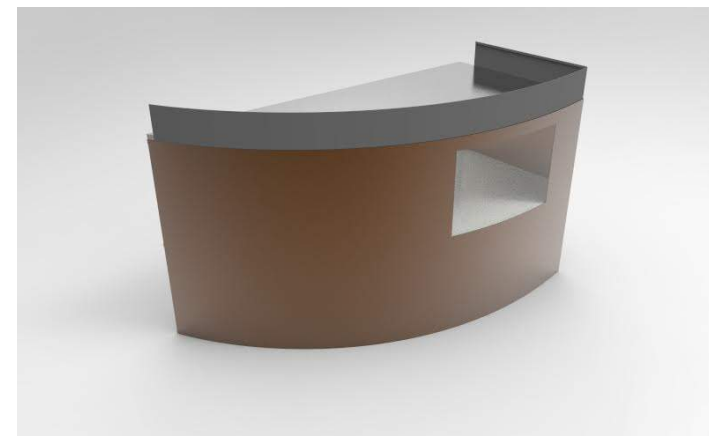

alternativa 3



alternativa 4

Mobiliario criterios de selección

suma ponderada

	Alt. 1	Alt. 2	Alt. 3	Alt.4
Elegante	3	4	5	3
Sencillo	5	4	3	5
Lujoso	2	4	3	3
Casual	4	2	5	4
Estable	2	4	4	4
Funcional	4	4	5	5
Higiénico	1	3	4	3
	21	25	29	27

matriz de cuatro ejes

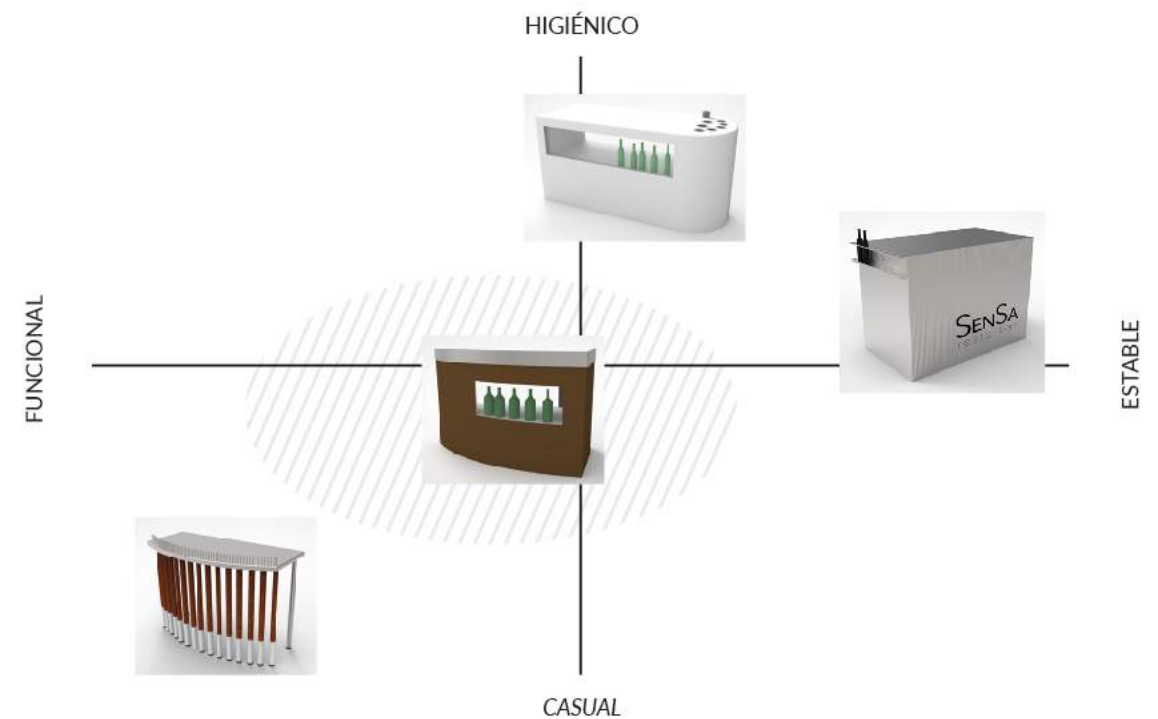

Mobiliario
solución adoptada

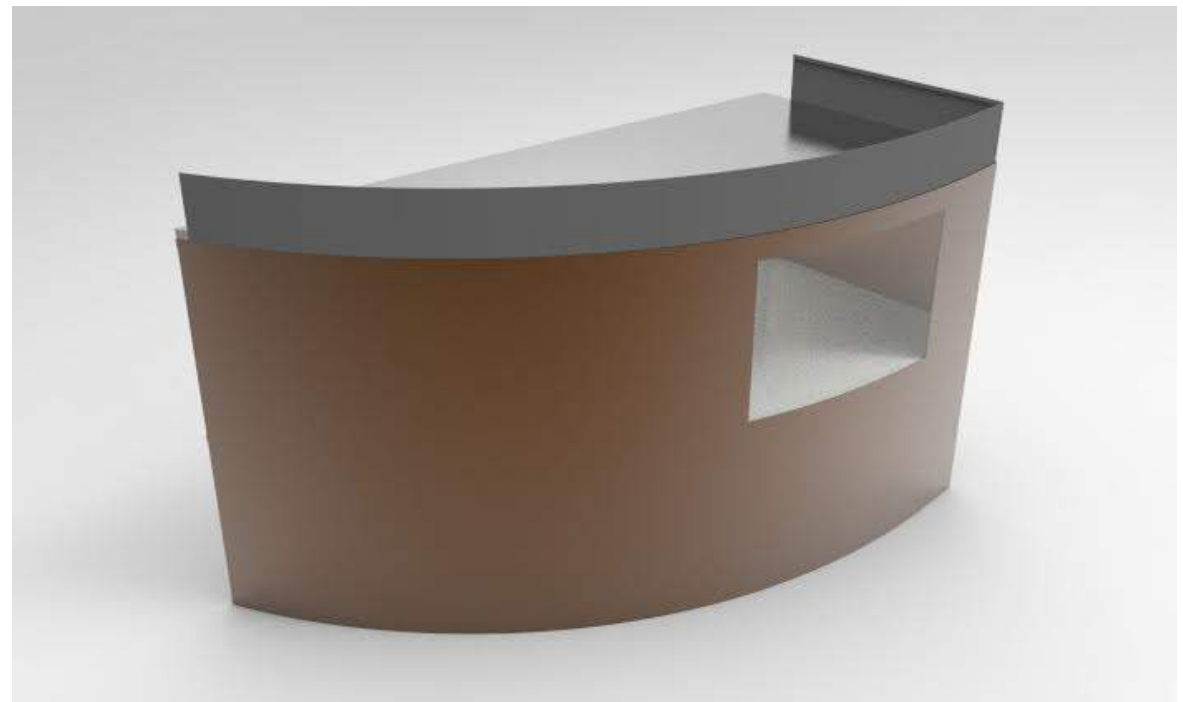
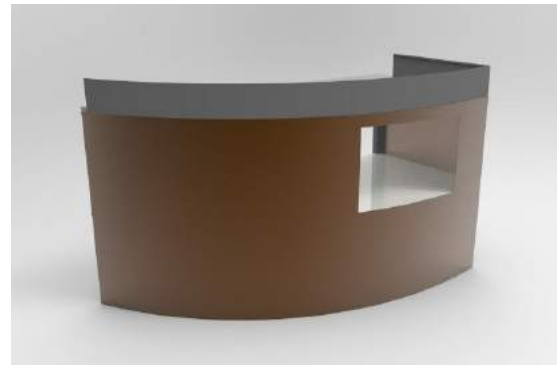

**Mobiliario
explosionado**

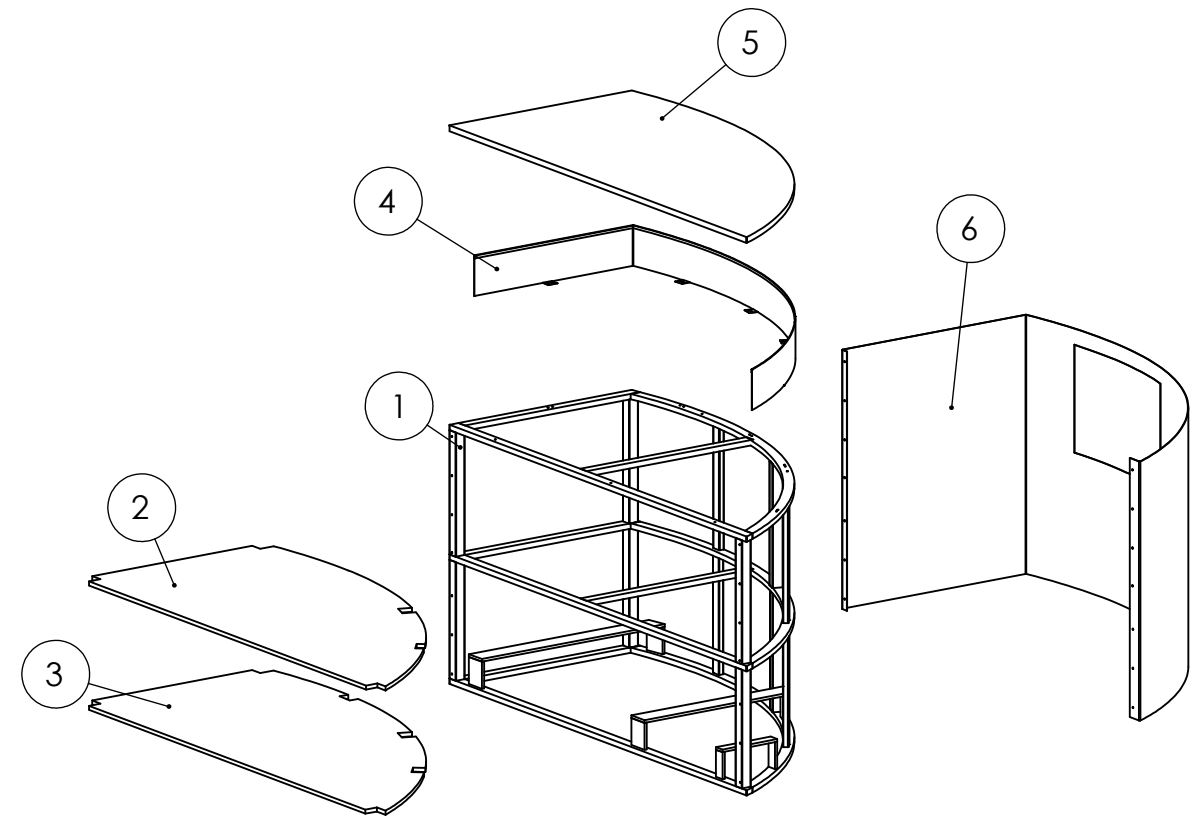

- 1 estructura
- 2 tablero estante superior
- 3 tablero estante inferior
- 4 baranda
- 5 conjunto superficie
- 6 conjunto chapa

**Mobiliario
materiales**



hierro galvanizado

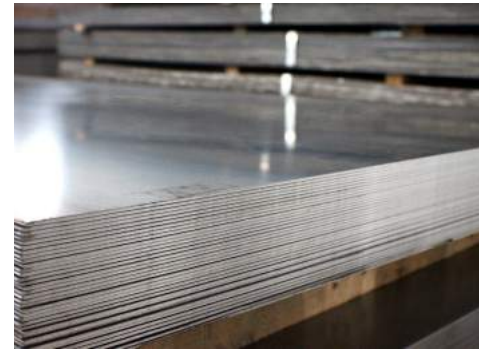

acero inoxidable 316

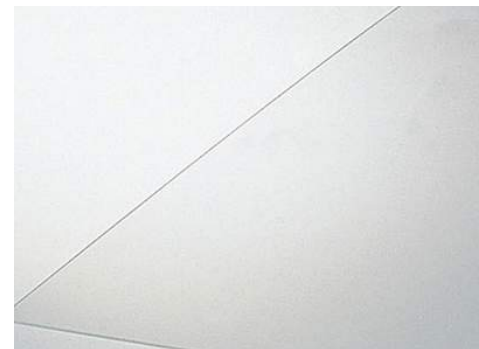

vidrioplástico



aluminio anodizado



aglomerado con HPL

**Mobiliario
montaje**

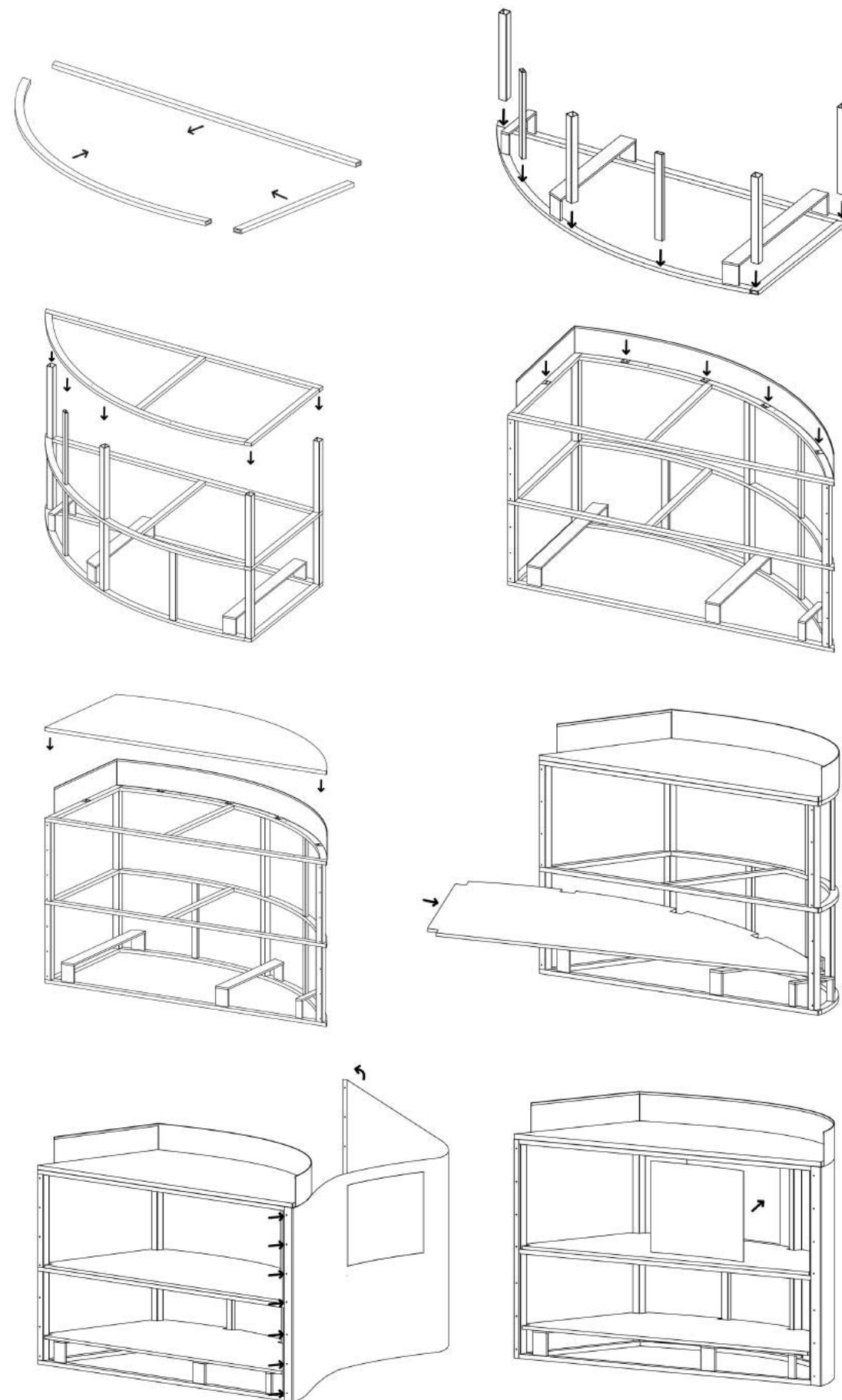

Mobiliario
producto final



Presupuesto

Diseño gráfico

Marca, logotipo y manual	1800,00 €
Papelería	
Tarjetas	200,00 €
Cartas	200,00 €
Banderola	200,00 €
Carteles A5	200,00 €
Chapas	200,00 €
Diseño interfaz web	1200,00 €
	<hr/>
	4000,00 €

Imprenta

tarjeta 500u	42,50 €
carta de comida 49u	235,20 €
carta bebida 34u	163,20 €
carta postres 24u	67,20 €
carta vinos 20u	56,00 €
banderola 1u	40,00 €
carteles A5 2u	6,00 €
vinilo de corte	15,00 €
	<hr/>
	625,10 €

Mobiliario

Materiales	381,68 €
Mano de obra	612,78 €
	<hr/>
	994,46 €

TOTAL

5619,56 €

Conclusiones

POSITIVAS

EXPERIENCIA VERÍDICA

TRABAJO EXPUESTO AL PÚBLICO

NUEVOS CONOCIMIENTOS

CONEXIÓN MUNDO REAL

gracias