





DIGITAL 3D RECONSTRUCTION OF BETANCOURT'S HISTORICAL HERITAGE: THE DREDGING MACHINE IN THE PORT OF KRONSTADT

RECONSTRUCCIÓN DIGITAL 3D DEL PATRIMONIO HISTÓRICO DE BETANCOURT: LA DRAGA DEL PUERTO DE KRONSTADT

José Ignacio Rojas-Sola^{a,*} , Eduardo de la Morena-de la Fuente^b 

^a Departamento de Ingeniería Gráfica, Diseño y Proyectos, Universidad de Jaén, Campus de las Lagunillas, s/n, 23071 Jaén, España. jirojas@ujaen.es

^b Programa de Doctorado, Universidad de Córdoba, Campus de Rabanales, s/n, 14071 Córdoba, España. edumorena@gmail.com

Highlights:

- A digital restitution of the 3D model of the Agustín de Betancourt's dredger, Port of Kronstadt, has been made, first of its type in the world.
- Elements not detailed in the original planimetry were intuited, and dimensional/geometrical hypotheses were made respecting coherence.
- For the characterization of different elements of the ensemble, the materials used at the time and the absence of normalization were handled.

Abstract:

Agustín de Betancourt was one of the most distinguished engineers of the 18th and 19th centuries with numerous contributions to various fields of engineering, including civil engineering. This research shows the process followed in documenting the cultural heritage of this engineer from the Canary Islands (Spain), especially in the geometric documentation of the Kronstadt harbour-dredging machine presented in 1808. The initial information was taken from the Canary Orotava Foundation, History of Science, which has been compiling information on the Betancourt Digital Project for years. In particular, there are only 8 colour illustrations without scale, as well as a small report on the description of the parts and the operation of a dredging machine previously designed for the Port of Venice (but never put into operation). This was the basis for the construction of the dredging machine for the Port of Kronstadt (Russia) that did go into operation in 1812 for more than 10 years. From this information, 3D reconstruction was made by means of Computer-Aided Design (CAD) techniques thanks to the use of the Autodesk Inventor Professional parametric software, which made it possible to build the 3D model and complete its geometric documentation as well as different detailed plans and exploded views. The results show a reliable approach to its modelling, a process in which several dimensional and operational hypotheses have had to be assumed due to the lack of existing information.

Key words: cultural heritage; geometric documentation; 3D reconstruction; Agustín de Betancourt; dredging machine; Autodesk Inventor Professional

Resumen:

Agustín de Betancourt fue uno de los más ilustres ingenieros de los siglos XVIII y XIX, siendo muy numerosas sus aportaciones a diferentes ámbitos de la ingeniería, en particular a la ingeniería civil. La presente investigación muestra el proceso seguido en la documentación del patrimonio cultural del citado ingeniero español, en particular, en la documentación geométrica de la máquina dragadora del puerto de Kronstadt que presentó en 1808. La información de partida se ha podido rescatar de la Fundación Canaria Orotava de Historia de la Ciencia que lleva años recopilando información sobre el Proyecto Digital Betancourt; en concreto, se ha dispuesto únicamente de 8 ilustraciones sin escala y en color, así como de una pequeña memoria sobre su funcionamiento y descripción de las partes de un ingenio de máquina dragadora que diseñó previamente para el Puerto de Venecia (pero que nunca entró en funcionamiento), y sobre el que se apoyó para la construcción de la máquina dragadora para el Puerto de Kronstadt (Rusia) que sí entró en funcionamiento en 1812 durante más de 10 años. A partir de dicha información, se ha obtenido su reconstrucción 3D, mediante técnicas de diseño asistido por computadora (CAD) gracias al concurso del software paramétrico Autodesk Inventor Professional, lo que ha posibilitado la obtención del modelo 3D y su documentación geométrica así como diferentes planos de detalle y perspectivas estalladas. Los resultados muestran una fidedigna aproximación a su modelado, proceso en el que se han tenido que asumir diversas hipótesis dimensionales y de funcionamiento debido a la falta de información existente.

Palabras clave: patrimonio cultural; documentación geométrica; reconstrucción 3D; Agustín de Betancourt; máquina dragadora; Autodesk Inventor Professional

* Corresponding author: José Ignacio Rojas-Sala, jirojas@ujaen.es



1. Introduction

1.1. Background

Agustín de Betancourt y Molina was a leading Spanish engineer who was born in Puerto de la Cruz (Tenerife, Spain) in 1758 and died in Saint Petersburg in 1824 and who contributed numerous inventions in different spheres of engineering, primarily civil (AA.VV., 1996; AA.VV., 2009; Bogoliúbov, 1973; Martín Medina, 2006; Muñoz Bravo, 2008; Padrón Acosta, 1958).

Betancourt received his training in different cities, but on his return from his stay in Paris and London in 1792 he was named director of the Royal Cabinet of Machines of the Palace of the Buen Retiro (*Palacio del Buen Retiro*) in Madrid (Spain). During the last months of power of the Count of Aranda, his patron and Secretary of State under Charles IV of Spain, Betancourt was commissioned to design a machine to dredge the ports of Cádiz and Cartagena (Spain). The destitution of Aranda and the arrival of Godoy to power resulted in the cancelation of some of the commissions involving Betancourt (Rumeu de Armas, 1990).

Though the years passed, the dredging project was not forgotten by the director of the Royal Cabinet. In 1808, when his stay in Paris was almost at its end, due to the breaking off of relations between Spain and France, Betancourt moved with his family to Russia. Meanwhile, his fellow engineer and friend Gaspard Prony, was named by Napoleon to inspect the ports of Ancona, Venice, and Pola. The French mathematician/engineer confirmed the urgency of cleaning the Port of Venice, almost blocked by sludge, and requested the help of his colleague Betancourt (Betancourt & Molina, 1807).

In this way the project of the dredging machine was instituted for use in the Port of Venice and required an explanatory report for its proper assembly, but it is unknown whether the dredger was ever used since a few weeks later the Spanish engineer left for Russia where he attended other affairs.

On his arrival to Russia, where he enjoyed the complete support of Czar Alexander, Betancourt put into practice many of the projects that had previously been cancelled. In 1810, being the inspector of the Department of Transport, he proposed the cleaning of the Port of Kronstadt, and for this he resumed the project of the dredger, based on the one sent to Prony, but substantially improved. The floating dredger for the Port of Kronstadt was successfully materialised in 1812 and was put into service until 1820 (Cioranescu, 1965).

The above reflects that the two documented dredging machines slightly differ. They have a common base in the original idea of the machine intended for use in Spanish ports, but the dredger used at Kronstadt is technically more perfected than the model proposed for the Port of Venice. The eight illustrations drawn in Russia for the Kronstadt dredger form the basis for the model built in the present study.

The present research continues the work undertaken previously on other historical inventions of Betancourt (Rojas-Sola, Porras-Galán, & García-Ruesgas, 2016; Rojas-Sola, & De la Morena-de la Fuente, 2017a; Rojas-Sola, & De la Morena-de la Fuente, 2017b; Villar-Ribera, Hernández-Abad, Rojas-Sola, & Hernández-Díaz, 2011) based on approaches to its 3D modelling.

On the other hand, the virtual 3D reconstruction has been the object of different works (Gutiérrez Baños, Morillo Rodríguez, San José Alonso, & Fernández Martín, 2016; Portalés, Alonso-Monasterio, & Viñals, 2017), but complementary to the information provided in the present study.

1.2. Aim

The present study seeks to build a faithful digital 3D model to reproduce the historical invention in order to examine results related to its geometric documentation such as the plans of the entire invention, exploded views, and detailed plans of its components, based on research, documentation, and dissemination.

Thus, based on the Principles of Seville (*Principios de Sevilla*) for virtual archaeology (Carta de Sevilla, 2012), which elaborates on the London Charter (2009) for visualization, the aim is to pursue authenticity, historical rigour, and scientific transparency.

2. Material and methods

The website of the Canary Island Foundation of Scientific History in Orotava has a section dedicated to the compilation and dissemination of the work of *Agustín de Betancourt y Molina* (Proyecto Digital Betancourt, 2017). Although the only material available of the historical invention on this website (Betancourt & Molina, 1808) appears in eight illustrations provided for digitalization by the National School of Bridges and Canals of the Paris Institute of Technology, the present research has included the report that Betancourt wrote to Gaspard Prony concerning the machine to dredge the Port of Venice and the sheets depicting the dredger (Betancourt & Molina, 1807).

The explanatory report on the plans of the dredger are dated on 15 May 1808 and, as explained in the web of the Betancourt project, the original illustrated sheets are preserved in manuscript 1478 of the Saint Petersburg State University of Transportation. This file contains eight illustrations in full colour. The first, numbered 4, is an elevation view of the dredging machine located on a steamship. The second (number 5) is a profile view of the dredger with the mechanism functioning, and the third (number 6) is a floor plan of the ship. The fourth (number 7), of particular interest, offers the same view of profile but with a longitudinal section of the ship, exposing the propulsion system of the dredger (the double-acting steam engine of Betancourt). The rest of the sheets (8 to 11) are detailed plans of the pieces making up the dredging machine and the system to gather up larger obstacles from the marine floor.

The drawings are without scaling and as in other engineering inventions, the emphasis was on the functional finality of the plan rather than measurement precision. Therefore, there are no references of scale and some details of the invention are not shown. For these reasons, it has been necessary to adopt certain geometric and dimensional hypotheses so that the ensemble would function properly.

However, the report and the drawings of the dredger of the Port of Venice have served to test some of these hypotheses in order to understand better some of the elements used by Betancourt. Thus, the conclusion was drawn that the engineer omitted some of the details of the dredger because they were already shown in the plans of

the French model, and therefore, he simplified the multiview projection, giving greater attractiveness to the overall machine. Also, the drawings of the Russian project could be used to convince Czar Alexander to approve the cleaning the port, and be used by the technicians in charge of constructing the dredger.

In addition, the methodology used was the digital restitution of the 3D model using Autodesk Inventor Professional 2016, which is a parametric computer-aided design software by Autodesk (Shih, 2015).

Below, the process followed in the 3D modelling and its geometric documentation is shown in detail with explanations for the restrictions applied, and the hypotheses adopted so that the design of the historical invention would be consistent.

3. Results

3.1. Considerations and functioning

The process of 3D modelling was complex due to the absence of detailed information, both drawn and written. The eight illustrations of the invention were up to scale, and therefore in this reproduction process the proportions were followed, taking measurements from the drawings to establish a faithful 3D CAD model. For this, different graphic scales were adopted so that the dimensions of the elements of the ensemble were the same as in the different drawings, giving consistency to the whole and finally providing a reliable model.

Even so, it has been necessary to establish some dimensional and geometrical hypotheses as well as movement restrictions (degrees of freedom) between the different elements of the ensemble, especially in the manoeuvring system for the transmission of motion as well as in the mechanical functioning of the bucket-dredging system.

As opposed to other parametric software used, the process of modelling with Autodesk Inventor Professional allows the components to be parametrically created individually (.ipt), and these can be modified in 2D with tools of the Autodesk family, such as AutoCAD, and previous drawings can be imported for later assembly of the whole (.iam) based on contact and movement restrictions of individual components, i.e. limiting their degrees of freedom. The limits of the program, while logical, are common to the constraints of the other comparable programs and therefore, for example, this limitation becomes apparent when ropes are modelled, which lose their dynamic properties. Figure 1 shows an isometric view rendered from the complete 3D model made with CAD techniques of the dredging machine.

This ship, of 33 m long, has a great number of elements. First, a double-acting steam engine (designed by Betancourt himself based on the James Watt invention) was meant to move dual inertia wheels that propel the two ladders of buckets, respectively, on either side of the ship. On the sides of the steam engine appear two cranes ending in clamshell to clear the marine floor of objects of larger size that could hamper the functioning of the dredge. Also, there are two horizontal axles in the bow, the purpose of which is to raise the dredge to the required height, and at the opposite end, four rods as the manoeuvring and lifting system of the dredger.

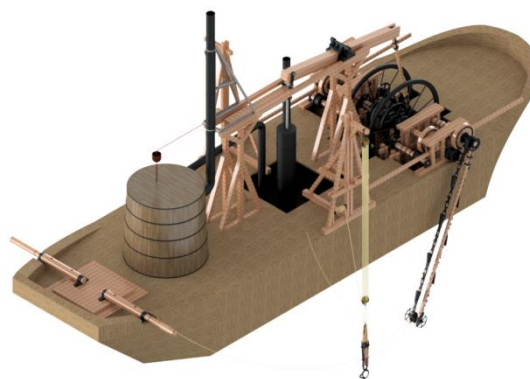

Figure 1: Isometric view of the complete 3D model

Figures 2 and 3 show, respectively, a plan of the ensemble and an exploded view or assembly of the dredging system. Figures 4 and 5 depict the plans of the overall system to gather up larger obstacles from the marine floor and the manoeuvring and lifting system of the dredger, respectively. Also, this allowed a study of the propulsion system of the dredger, since it is such a complex system that it should give rise to a separate study, based on an adaptation of the double-acting steam engine of Betancourt himself.

However, given the extraordinary complexity of the dredging machine, as well as the limited space of scientific articles, this study was confined to the dredging system, the true pillar of its functioning.

This is a Louis-type bucket ladder, as stated by Betancourt himself in the report that he wrote for the dredging machine of the Port of Venice (Betancourt & Molina, 1807). The dredging system was designed not exclusively to remove sludge and mud from the bottom of ports but also to move the ship. In other words, the buckets were not only to remove soil from the bottom, but also functioned as a worm-like mechanism to facilitate the ship's movement.

For an understanding of the functioning of such a complex mechanism, the following explanation is based on Figure 2. It is known that the propulsion mechanism moves an axle coupled to the joint of the two rocker arms (4). The main rocker arm (2), the one situated nearer to the dredger, has a connecting rod (26) on one end to a rod and joined to a very particular crankshaft (25) since it moves two large inertia wheels (5), and these are fixed to an axle (22). Thus, the rod and crankshaft transform the rocking movement into rotation.

The main axle of the dredger (24) in turn has a gear wheel in its middle zone that meshes with two auxiliary crown wheels (6), joined to the framework of the mechanism (1), and that in turn meshes with the two auxiliary crown wheels (23) fixed to the two axles.

In its distal area, the main axle has a drive wheel (20) that transmits the movement of the friction drum (7) of the dredger axle (24). In turn, the dredger axle moves the drive gear of the dredger (28), in such a way that the relation of turns between the inertia wheel and the drive gear is inversely proportional to the relation between the diameters of drive gear and the inertia wheel (720 mm/1493 mm), this translating into the situation that for each turn of the inertia wheel, the drive gear turns half a revolution.

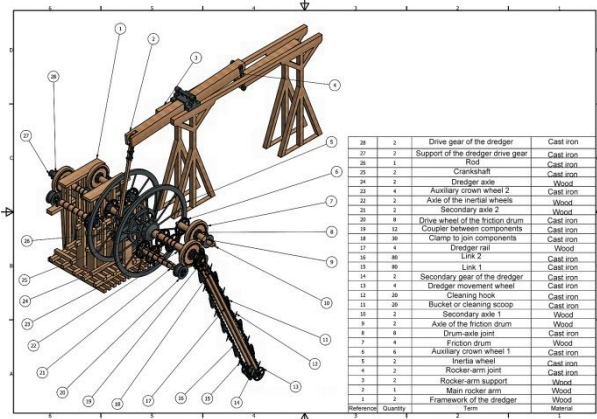

Figure 2: Plan of the overall dredging system.

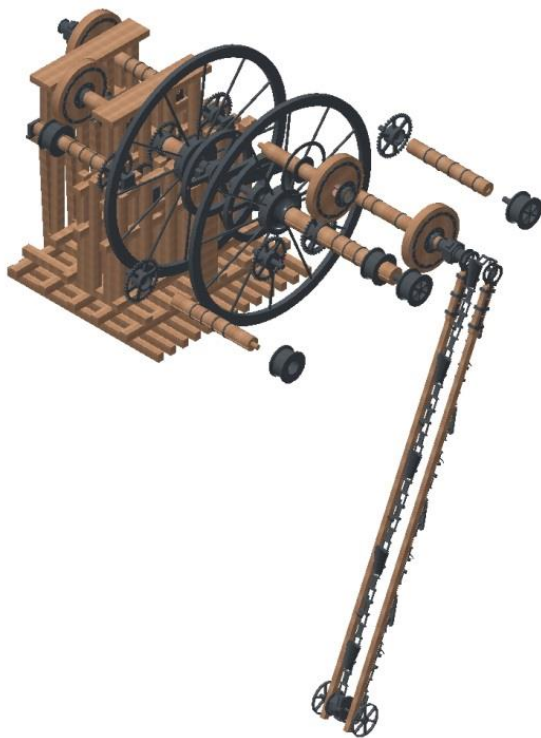

Figure 3: Exploded view of the dredging system.

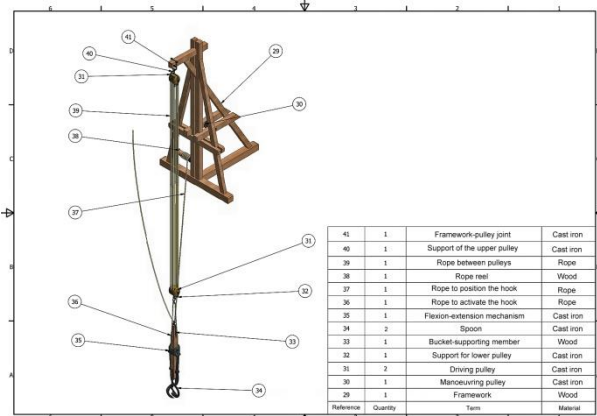

Figure 4: Plan of the overall system to gather up larger obstacles.

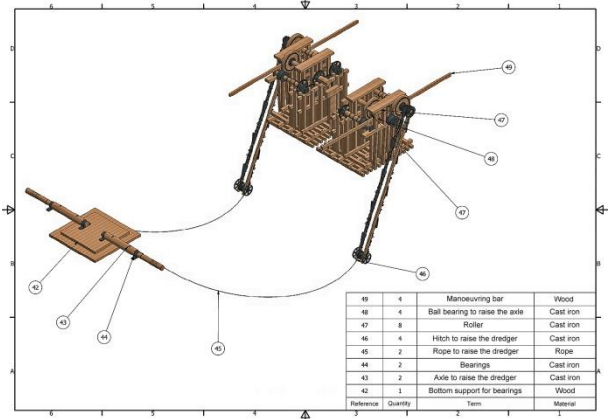

Figure 5: Plan of the overall manoeuvring and lifting system.

The contact of these axles by the drive gear and the friction drum have several objectives: to support the axle and easily separate the axle of the dredger from the main axle, stopping the machine.

As mentioned above, the main axle moves two secondary parallel axles (21 and 10) of similar characteristics, doing so thanks to a set of straight gears. These are two simple axles that have a crown wheel on their end (23) that meshes with the auxiliary crown wheels (6), and a drive wheel (20) that serves as support for the friction drum.

Between the main axle and the secondary one there is an axle of the friction drum (9), similar to the one of the dredger but that does not transmit movement to any gear, and that appears tied to a rope in the drawings. The purpose of this parallel axis is to accelerate or slow down the velocity of dredger.

The dredger consists of a ladder of buckets or scoops for cleaning (11). These buckets are fixed by a chain of alternating iron links (15, 16) that mesh with the drive gear of the dredger (28). This gear has two truncated-pyramidal teeth that facilitate the proper contact with the chain so that every three links a bucket (11) or a cleaning hook is positioned (12), also alternating.

The bucket-chain of the dredge remains taut because of a dredger rail (17) ending in a secondary gear of the dredger (14) at the same end. Also, so that the dredger rail can be easily moved along the marine bed, there are also two metal wheels (13) of 750 mm in diameter on the sides of the secondary gear that do not interfere with the movement of the dredger. This system offers the mechanical advantage that in case of striking an element that could block the dredger, given that the axle drum of the dredger makes contact only with the drive wheel, if the drum abruptly quits turning, the wheel continues sliding, as there is no set of gears in between. Thus, the mechanism suffers substantially less given that there is no possibility of breakage.

3.2. Modelling of the ship and other elements of propulsion

As opposed to other dredgers in existence during that period (e.g. the Evans dredger put into action in the USA in 1805), Betancourt's dredger was mounted on a ship, making it completely original.

The first structure of the dredger to model is the ship. Betancourt was aware that the dimensions of the ship were not especially determinant when installing the

dredger, and thus did not specify its width, length or draught. For the modelling of the ship, the shape was kept as similar as possible to the drawings, although a ship of these characteristics (without a keel or rudder and so flat) greatly hampered its navigation and handling.

It measured 33.60 m long, 9.26 m wide, and 3.6 m hold depth (Fig. 6).

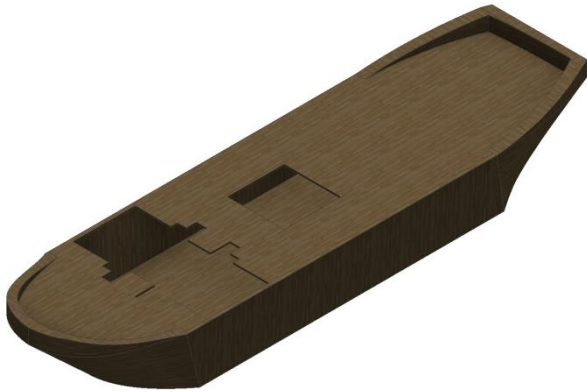

Figure 6: Axonometric view of the ship.

As it can be appreciated, the deck has openings to set up a number of structural components both of the dredger as well as the elements of propulsion.

As it is indicated above, the propulsion elements, smokestack, steam engine, boilers, returns, support structures, etc. were modelled, but for the aim of the present study, where the main elements are others, the choice was made to model them in an illustrative way, and thus no in-depth analysis was made of their parts or dimensions. Thus, a wooden furnace was modelled, with a smokestack and steam pipe in the form of an L, and in order to hold up the main funnel, Betancourt had designed a metal support structure. Also, the double-acting cylinder contains a piston in the form of a T that connects with the joint between rocker arms, and, finally, the cooling stack was modelled together with a copper return to make use of the condensed water in this stack (Fig. 7).

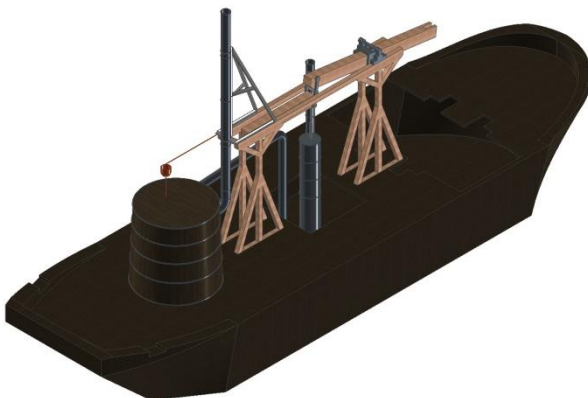

Figure 7: Axonometric view of the ship with the propulsion elements.

3.3. Modelling of the rocker-arm/crankshaft

The first system to model, without which it could not be understood how the propulsion motion reaches from the cylinder axle to the dredging axes, is the rocker-arm/crankshaft structure. This presents a number of

complexities in its design that must be addressed so that the structure functions properly afterwards.

The first element to model is the support for the rocker arms. This wooden support is a kind of gantry designed to support the weight of the rocker arms and the metal frame of the smokestack (Fig. 8).



Figure 8: Axonometric view of the rocker-arm support.

The following element is the support of the axle of the main rocker arm. This rocker arm, due to its weight, has a plain bearing that houses the axle. This support has an interior diameter of 150 mm and a width equal to that of the support beam on which it is situated (Fig. 9).

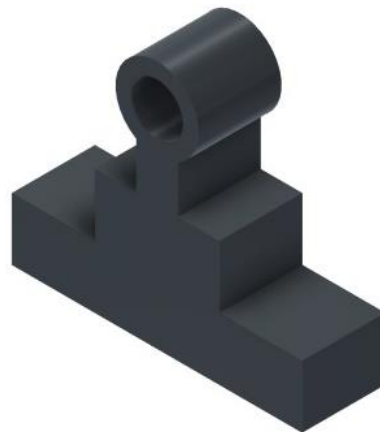

Figure 9: Axonometric view of the metal support of the rocker-arm axle.

The following element, perhaps the most important one, is the main rocker arm. This is a beam of 8.28 m long and a square section of 600 mm per side. In the middle it has a metal axle attached to a square four-sided metal clamp connected to the axle of the cylinder and another that connects to the rod (Fig. 10). This element, consisting of two independent parts, is modelled separately and afterwards joined together. On importing the assembly of this rocker arm to the general assembling, it behaves as a single piece although with its own material properties.

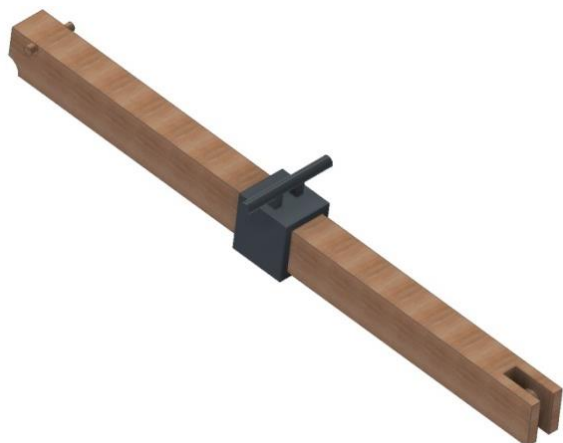

Figure 10: Axonometric view of the main rocker arm.

The secondary rocker arm has certain functions in the operation of the steam engine, but it determines the functioning of the main rocker arm. It measures 4.32 m long and has the same dimensions in section as the beam of the main rocker arm. At the ends is a wooden axle to join to the support and another of smaller dimensions to connect to the cylinder piston axle (Fig. 11).



Figure 11: Axonometric view of the secondary rocker arm.

The connection between the rocker arms and the axle of the cylinder piston is crucial. This is a metal joint with a special geometry, presenting three holes, two in the ends and one in the middle and furthermore each should couple snugly to the axle it is intended for (Fig. 12).



Figure 12: Axonometric view of the coupling of rocker arms and the piston axle.

On the other hand, the rod is formed by a wooden strip rectangular in section (120 x 150 mm) and 6 m long but the end segments have somewhat larger dimensions (120 x 240 mm). Connected to the faces of these segments, there are two metal pieces with the geometric shape to fit tightly both to the axle of the rocker arm as well as to the crankshaft axle. These metal elements are fixed to the wooden end segment by three iron clamps that ensure against its movement (Fig. 13). As in the case of the rocker arm, it was necessary to create an assembly of the rod that includes metal and non-metal elements.



Figure 13: Axonometric view of the rod.

The metal crankshaft is formed by two wheels of enormous dimensions joined by an intermediate area where the axle is offset from the centre, such as a satellite. The metal wheels, with 12 spokes each, have a diameter of 5.20 m. This is a structure with a total width of 2.59 m. The centre of the satellite has an eccentricity of 1.35 m and at this point the axle has a diameter of 300 mm. Figure 14 shows its geometry more clearly. This element transforms the rocking movement into a rotating one.



Figure 14: Axonometric view of the crankshaft.

The final element to model is the support for the crankshaft. The central axle of the crankshaft has a diameter of 160 mm, so that the support, which should be resistant and therefore is metal, has a bearing with the same geometry (Fig. 15).

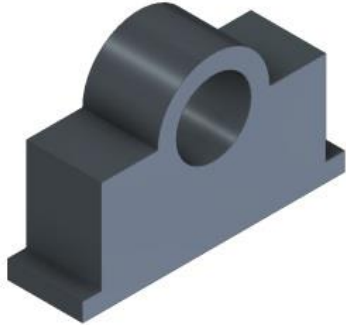

Figure 15: Axonometric view of the support for the crankshaft.

3.4. Modelling of the structure of the dredger

The structure of the dredger displays Betancourt's ingenuity and mastery of mechanics. Firstly, the framework supporting the transmission mechanism of motion must be modelled. The wooden framework receives all the weight both of the axles as well as the dredger itself, and therefore it should be a robust structure. Furthermore, the structure should be well installed with respect to the hold of the ship, being geometrically compatible with the walls of the ship. With these data, and knowing that the structure had five axles, Betancourt designed the supporting framework of the dredger (Fig. 16).

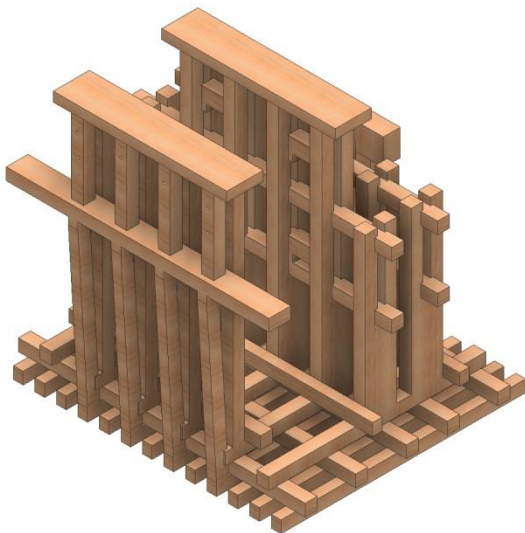

Figure 16: Axonometric view of the framework of the dredger.

This support does not require nails, as the wooden structures interlock in a compact unit, as it can be appreciated in Figures 17 and 18.

The elements of the system that remain to be modelled are five drive shafts of the dredger. All of them have a certain analogy and a common base, but they have their own particular elements. First, it is the axle that transmits movement from the inertia wheel to the rest of the axles and crown wheels (Fig. 19). It is composed of a cylindrical

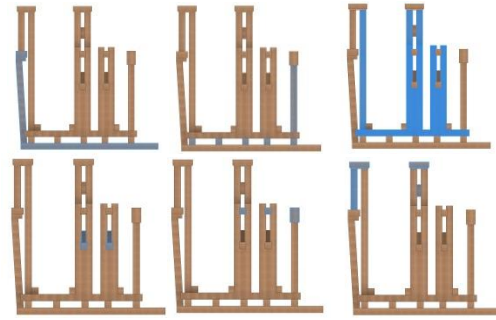

Figure 17: Lateral view of the support of the transmission: assembly sequence.

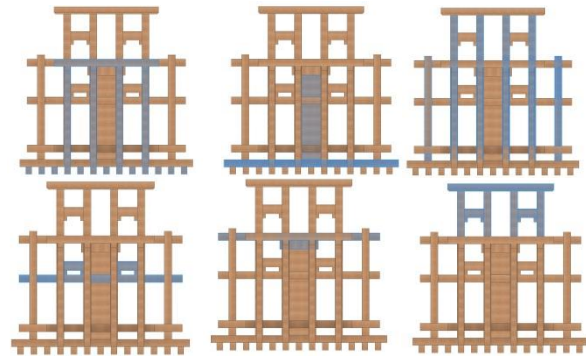

Figure 18: Elevation view of the support of the transmission: assembly sequence.



Figure 19: Axonometric view of the axle of the inertia wheel.

wooden member 400 mm in diameter and 3.115 m long, which has a lateral channel to allow adjusting the different elements. Furthermore, it presents a gear 1 m in diameter with 38 cogs and two drive wheels on the opposite end from the gear. This presents a diameter of 720 mm and a width necessary to join tightly with the friction drums of the other axles.

All the transmission axles have metal and non-metal elements. Evidently, this axle functions as a single piece, but in fact each piece must be modelled independently. After independent modelling, the components are assembled apart and are imported to the general assembling as a single piece but maintaining individual physical properties. This modelling process was followed for all the axles.

The axle of the dredger transmits the movement to the dredger near its gear (Fig. 20). This is composed of a cylindrical wooden member 400 mm in diameter and a

length of 3.33 m, and on one of the sides has a friction drum of large dimensions (1.493 m in diameter and 200 mm in width). On the end of the same side, there is a hexagonal pinion bearing a truncated pyramidal relief on alternating sides of the hexagon. The hexagon is 240 mm per side and the truncated pyramid is 60 mm high, with a base measuring 120 mm by 180 mm. The width of the pinion is 255 mm. These dimensions determine the length of the links.



Figure 20: Axonometric view of the axle and the pinion of the dredger.

The friction drum blocks the movement of the dredger axle (Fig. 21). Its wooden axle has a diameter of 400 mm and a length of 2.0 m, and on one side has this friction drum of equal dimensions as the one fixed to the axle of the dredger.



Figure 21: Axonometric view of the axle and friction drum.

The secondary axle 1 (Fig. 22) transmits the movement from an auxiliary crown wheel, propelled by the axle of the dredger to the friction drum, and functions to support that drum. It is made up of a cylindrical wooden member of 400 mm in diameter and 2.38 m long. Also, the member has a lateral channel that enables the adjustment of the different elements, as in the case of the main axle. Furthermore, on its end it has a gear with 38 teeth and measures 1 m in diameter, and a drive wheel on the side opposite the crown wheel. The wheel has a diameter of 720 mm and a width necessary to fit tightly with the above-mentioned friction drum.



Figure 22: Axonometric view of the secondary axle 1.

The secondary axle 2 (Fig. 23) transmits the movement from an auxiliary crown wheel, propelled by the axle of the dredger to the friction drum of the dredger axle, and, as in the previous case, it functions to support this drum. It is made up by a cylindrical wooden member 400 mm in diameter and 2.22 m long, also with a lateral channel. On its end it has a gear of 38 teeth and 1 m in diameter and, on the opposite end, a drive wheel of the same characteristics as the other drive wheels.



Figure 23: Axonometric view of the secondary axle 2.

After the modelling of each of the axles, two auxiliary gears are left to be modelled, these being metal and indispensable for the proper functioning of the transmission mechanism (Fig. 24).

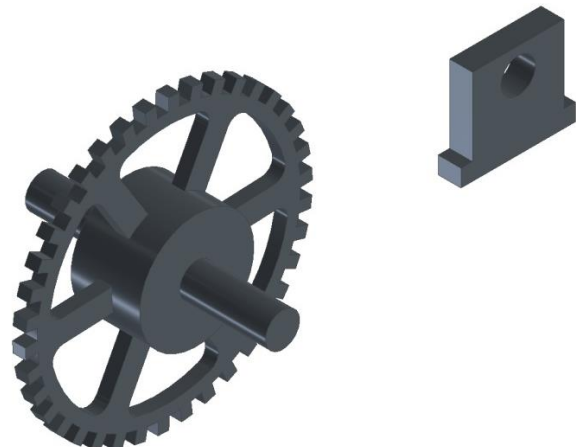

Figure 24: Axonometric view of the gear and support.

Following the modelling process of all the elements of the transmission system, the components of the dredger were modelled. The first element of the dredger was already modelled, i.e. the gear of the dredger axle by which all of the components of the machine are moved. Also, to the right and left of the gear appear two support axles called rails (Fig. 25).



Figure 25: Axonometric view of the dredger rail.

Each rail is formed by a strip of wood rectangular in section (120 x 150 mm) and 10.05 m long. On the end close to the pinion, the dimensions of the bottom section are somewhat greater (120 x 240 mm), and attached to the sides are two metal elements shaped to fit the axle of the dredger. To join these two metal elements to the bar, three iron clamps are used to stop any movement, and on the opposite end a hole is drilled to receive the wheel supporting the bucket ladder. Again, the metal and non-metal pieces are modelled separately and then assembled.

Next to be modelled were the wheels of the metal axle that would go in the lower part of the rail (Fig. 26). These wheels, joined to the axle, must be smaller in dimension than the working distance of the buckets and hooks of the dredger, since if larger, the dredger would not be able to touch the marine floor. In this study, the wheel diameter used was 750 mm.

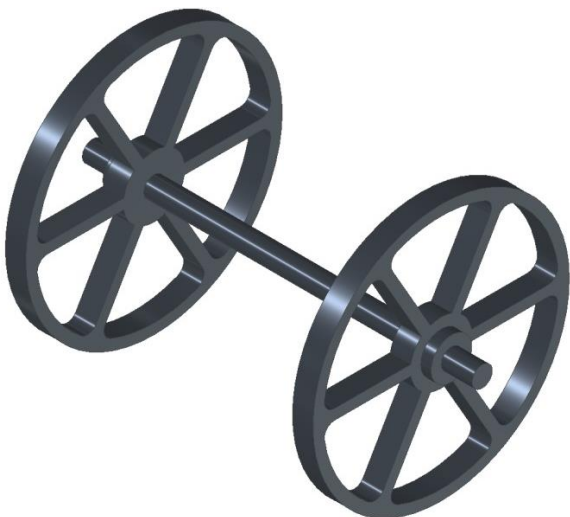

Figure 26: Axonometric view of the axle wheels.

The axle that was just modelled is common for the lower pinion of the dredger and this has a geometry similar to that of the upper pinion, except for two differences: the lower pinion has no relief on its sides and furthermore it has two lateral flanges to prevent any object from blocking it (Fig. 27).

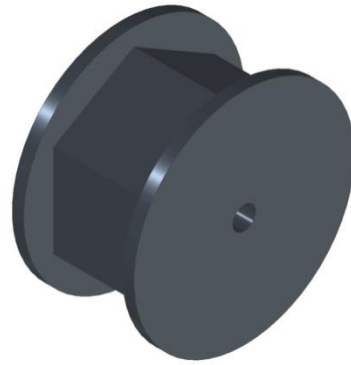

Figure 27: Axonometric view of the lower pinion.

Thus, the links of the chain with the actual dredging instruments were modelled. These links present one step between their axles of 270 mm, and there are two models (male and female), which alternate in order for the pinion to interlock properly with the chain formed. The links are metal and have a geometry that allows them to interlock properly. The male link has connections that project beyond the hole of the female link in order to be able to couple the dredging instruments (Fig. 28).

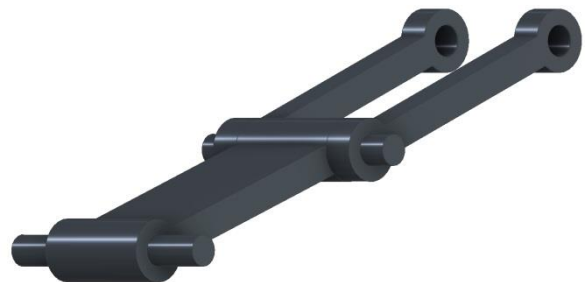

Figure 28: Axonometric view of a pair of links (male below, female above).

Also, there are two implements of the dredger: the buckets or cleaning scoops and the hooks. These alternate over the male links, leaving a link always free.

The bucket has a very particular design to try to capture the greatest quantity of soil and sludge from the marine bed. These are metal and are perforated to strain the water and reduce the total weight. The upper edge is pointed to work as a shovel to scrape the marine floor. However, the hook is a simple tool in the form of a pick that has the necessary shape to be inserted into the bucket ladder (Fig. 29).



Figure 29: Axonometric view of the bucket and hook.

3.5. Assembly of the dredging system

The final assembly was determinant for the overall mechanism to function correctly and afterwards to be used for the simulation of movements or for the static analysis. Therefore, it is indispensable to follow a logical order of construction.

First of all, the rocker arms must be assembled. Thus, over the nearest support closest to the aft of the ship, in the high part of the support, the two metal pieces are placed, these being the true supports of the axle of the rocker arm. Each piece is inserted over this site, using restrictions of alignment with the borders.

The following step is the assembly of the axle of the main rocker arm. This piece is already assembled with the rocker arm and therefore it needs to be assembled by insertion into the hole in the joint of the rocker arms. This provides the member of the rocker arm freedom of movement in turning so that it can rock as the piston rises and falls.

The secondary rocker arm has two dowels that allow the closer end to be inserted into the prow, with the holes of the support. For this, the movement is restricted simply by insertion, with this hole making the second member rock with respect to the axle. The following step is to join the two rocker arms, and for this the metal joint of the rocker arms must be assembled, i.e. two pieces of bar with three holes.

The piece is placed in such a way to restrict the movement of the hole by inserting it in the dowel at the end of the main rocker arm. This should be done using the holes in the ends and leaving the one in the middle open, so that the rocking movement of the two arms is restricted, one depending on the other, as intended.

The movement of the two rocker arms depends on the piston referred to above. The end of the piston forms a T and, for its correct assembly, the upper part is restricted by insertion in the hole that has remained free, and the other end of the axle is restricted by insertion in the hole of the cylinder. In this way, the piston can rise and fall, moving both rocker arms.

On the other end of the main rocker arm, the rod is assembled by insertion into the hole of its end with the axle of the aft end of the rocker arm. In this way, the rod can rotate with respect to the axis of the rocker arm, whose motion finally is oscillating (Fig. 30).

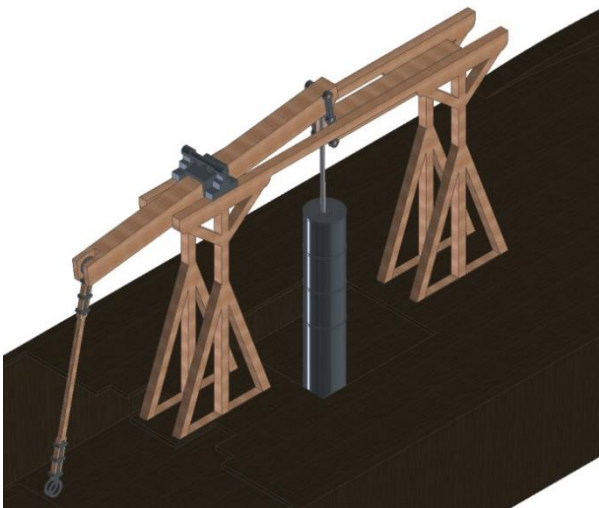

Figure 30: Assembly of the rocker arms, rod, and cylinder axle.

The next step consists in assembling the structure of that transmits movement by axles and gears. Thus, the first step is to fix in their position the two frames to support each dredger, one on each side. For this, again, the restriction of opposition is used with the depth of the hold and aligned with the slot made in the deck for this insertion.

Over the support, firstly, the bearings must be placed to support the large crankshaft in the area nearest the centre of the ship, and a bearing is positioned on the support of the port side and another on the starboard, so that the crankshaft is held by both supports. The assembly of the bearings is by opposition and alignment, restricting all its movements. The crankshaft, on the contrary, is assembled only restricting by insertion into the bearing, so that it can rotate freely.

On the other hand, from the above system, the free end of the rod remained to be fixed. Now this end can be restricted by inserting it into the planetary axle of the crankshaft. With this simple assembly, the oscillating movement of the rocker arm is transformed into a rotational movement of the crankshaft.

To insert the axles, their supports are previously assembled. The supports make a total of 10 per frame, excluding the crankshaft, and they should be fitted exactly in place. They put in place, restricting their base by opposition and aligning their edges with those of the space into which they fit. Once these axles are inserted, the proper fitting of the other axles proves easier. The main axle is continuous with the axis of the crankshaft, and so that they move together, the ends are fitted together end to end. Afterwards, with a restriction of rotation, with each turn of the crankshaft, the main axle is also forced to turn. In this way, they work firmly together.

If the main axle is correctly in place, it will also be inserted into its support. In any case, to define better the contact points for future works, it is necessary to restrict the motion of the axle by inserting it into the aforementioned hole also. This does not impede the motion of the axle if it is correctly aligned. If the software does not permit this, the support restrictions have to be deactivated, the hole of the support must be restricted by insertion into the main axle, and afterwards its bottom must be opposed at its point of support. But if it is not well aligned by geometrical errors of the support, the simulation will be impossible.

The following elements to assemble are the auxiliary crown wheels. On the one hand, these elements are assembled by restricting their movement by insertion of the axle with the support established, and on the other hand, the rolling must also be restricted with respect to the main axle. With each turn, the auxiliary crown wheel turns it in the contrary direction. When the crown wheels are finished, the secondary axles must be assembled. These are also restricted with respect to the auxiliary crown wheels, and in this way they turn in the same direction as the main axle.

The most important axles remain to be assembled: the axle of the dredger and the friction axle (Fig. 31). With these axles, special care must be taken because they are not assembled like the rest. On the one hand, the movement is restricted by insertion in their support in the same way as the rest, but on the contrary to what it might seem, the turn of the inertia wheel does not have to be submitted to the rotation of the drive wheels. This would

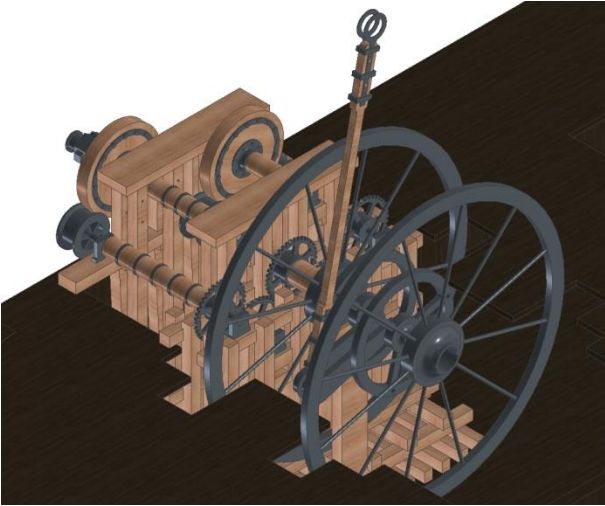

Figure 31: Assembly of the transmission system of movement.

be the normal behaviour when the desire is to dredge and the desire is not to use the breaking of the friction drum, but sometimes contact between elements can be eliminated by using the manoeuvre bars (to halt the dredger or to reduce its speed by friction), and they would continue functioning. For this, the only thing that must be done is to click on the command "Activate outlines" between the axles and the driving wheels, since by doing so the software determines whether there is contact between the surfaces and acts accordingly.

Next the dredger has to be assembled. The components themselves are complex to put together, as they constitute a chain. In fact, the bucket ladder must be assembled apart and afterwards put in place. To determine the number of links to use requires knowing the distance between the two pinions of the dredger, i.e. the upper and lower, and therefore the assembly of this group had to begin at this point.

The assembly of rail is not complex. The rail is taken by the side of the ring and it is inserted next to the upper pinion, restricting the opening of the ring by insertion with respect to the axle of the dredger. This must be repeated on the opposite side of the pinion, as the rail is formed by two strips of wood, and this causes the strips to be free and rotate over the axle of the dredger.

Next, the lower wheels are assembled, also by restriction of the insertion of the axle of the wheels with the holes that appear in the two strips for this reason. With this operation, the strips move in a synchronized way and the wheels turn freely. Over the axle of the wheel, the axle of the lower pinion is inserted, repeating the same procedure and making sure that the gear turns freely over the axle of the lower wheel. The lower pinion should remain between the two strips of wood and therefore on restricting it by inserting the axle, it must be aligned with respect to one of the wooden strips.

The following step is the assembly of the dredging chain. As it is noted previously, the male and female links are attached alternately, making sure that the edges of the links are aligned and not the axle of the male link, since this should project to make room for the rest of the pieces. This procedure must be repeated until just completing the double of the distance between pinions.

Next, the buckets and hooks must be placed using restriction by insertion. As it is commented above, these

are placed only on the male links. Also, it is necessary to do this alternatively and in the correct direction, so that the points face the soil, since if not, it would fail to remove anything from the marine floor. Thus, the assembly sequence would be to insert the two holes of the ends of the bucket on the axles of one link, and the following male link would be left free; afterwards, two connectors on the outside of the cleaning hook are inserted, and the following male link is left free. Because of this sequence, the number of links must be a multiple of 4. In the present study, 80 links were used, 40 male and 40 female, plus 10 buckets and 10 cleaning hooks, the same as shown in the drawings of the dredger of the Port of Kronstadt.

As it is indicated above, once the bucket ladder is put together, it must be placed into position; this process being somewhat complex. One female link is fitted onto the upper pinion and for this their movements must be restricted by opposition and alignment in the three directions, fixing this link to the pinion. Immediately afterwards, the pinion must be temporarily blocked so that it does not change position (fixing the element), and then the chain is carefully stretched. The process is tedious because some links must be blocked one by one. Once stretched, when the next female link is in place opposite the upper one, the fixations are eliminated from all the links except for the first one. Then the movement of this last link is restricted, as done with the first one and it is



Figure 32: Assembly of the dredger elements.

properly set around the lower pinion and again this last link is fixed. With these last two links fixed, the rest are placed given an approximate shape and avoiding contact with the pinions or the rail. The last step is to remove the restrictions of the two opposing links, eliminate the fixations, and activate the set of contacts between the links and pinions (Fig. 32).

4. Discussion

The action of recreating Betancourt's dredger from the original plans helps us to materialise and concretise the model that the Canary engineer had in mind. However, when the available graphic documentation on the dredging machine of the Port of Kronstadt is analysed, there is not a reference to any scale and true measures to facilitate appropriate information of the different elements. On the other hand, Betancourt did not pretend to provide detailed information about size, dimensions and tolerances of each part of the mechanism. His intention was to present a functional and informative plan that would serve as an illustration when presenting the model to a promoter. It was remarkable the degree of precision in the drawings and details (in fact, the artistic and technical training of the engineer was very careful).

The 3D modeling of the dredger has helped to realise part by part the dimensions of each mechanism. It has facilitated the understanding of the elements' functionality by determining all their contacts, solving the mechanism situation, and it has also determined the need and deficiency of the materials used. Finally, it facilitated the later structural analysis of the mechanism and allows us to simulate the dredge for a virtual recreation.

Another advantage of this 3D modeling is that it favours the understanding of the construction process of the invention. A panoramic and finished view of the dredging machine does not allow users to see the complexity of the assembly. Betancourt clarifies in the reports accompanying their engineering drawings, the engineering necessity to reach its proper functioning. Modeling each part (assembling them in their position and defining their movement) and contrasting it with the memory of the invention, shows his mastery in facilitating the correct assembly of the work, surprising the modeler with the detailed knowledge he had about process engineering.

Finally, virtual recreation of the dredger is a long and complicated task due to the large number of parts and restrictions. In addition, it is necessary nowadays to use complex professional software with high computational requirements. The time-consuming process requires being patient because it is iterative: It starts from initial conditions (a priori established measurements) that must be subsequently checked and corrected. This analysis and subsequent evaluation should lead to a harmonious and possible solution for the materials and limitations of the time.

As it is indicated above, there are no studies of Betancourt's civil works previous to those shown in our research line. The mechanical dredger has been graphically modelled in 3D for the first time in the present work. There is a simplified model of the dredger in the Orotava Foundation made from the original plans that gives an idea of the structure, but that has no technical utility. The present work is original, unpublished and

pronounces a technical judgment about a work that has only been studied from a historical point of view.

5. Conclusions

The machine designed by Agustín de Betancourt to dredge seaports has been modelled in 3D with the scant historical documentation available, i.e. only 8 colour illustrations without scaling, using for this the parametric software Autodesk Inventor Profesional.

The first known attempt by Betancourt to design a dredging machine was never put into practice, but the machine in the Port of Kronstadt functioned for more than 10 years, being without any doubt one of the first dredges to be used (probably the first mounted on a boat). Given the importance of dealing with a historical mechanical invention, with such peculiar characteristics, efforts were made at all times in the present study to make a 3D model as close to the original illustrations as possible, although this required certain hypotheses concerning dimensions and functioning of the machine, as this information lacked the precision of present-day construction plans. For this, the elements were in all cases designed to follow the original proportions and had a consistent functioning, this being aided by the report on the first dredger designed for the Port of Venice in 1807.

The result of all this work is the virtual recreation of the dredger's functioning and its assembly, exclusively for learning and research purposes, and for the recognition and dissemination of the work of the acclaimed engineer. In addition, as a future development, the dredger will be printed in a high-quality 3D printer, ensuring the functioning of the machine.

From the 3D geometric documentation of the dredger, its behaviour can be studied with CAE (Computer-Aided Engineering) tools that incorporate the same software, namely Autodesk Inventor Simulation, by a static analysis to determine in all cases the von Mises stress, deformation, displacement, and coefficient of safety of the invention, as well as the use of classical engineering for confirmation purposes.

The present study yields an enhanced vision of the Canary Islands engineer, Agustín de Betancourt, giving depth to the exclusively historical heritage that we achieved from his work such as the dredging machine in the Port of Kronstadt (Saint Petersburg).

Acknowledgements

This work was developed as part of the research project entitled "*El patrimonio histórico de Agustín de Betancourt: estudio integral de las aportaciones a la ingeniería civil desde la ingeniería gráfica para su puesta en valor y difusión*" (HAR2015-63503-P), funded by the *Ministerio de Economía y Competitividad* (MINECO), in the *Programa Estatal de Fomento de la Investigación Científica y Técnica de Excelencia, Subprograma Estatal de Generación del Conocimiento*, within the framework of the *Plan Estatal de Investigación Científica y Técnica y de Innovación 2013-2016*, and by European Regional Development Fund (ERDF).

Also, we wish to express our most sincere appreciation to the Fundación Canaria Orotava for their kindness and authorization to use the material of their web, as well as the Fundación Juanelo Turriano for awarding one of their esteemed doctoral grants.

References

- AA.VV. (1996). *Betancourt: Los inicios de la ingeniería moderna en Europa*. Catálogo de la Exposición del Centro de Estudios Históricos de Obras Públicas y Urbanismo (CEHOPU). Madrid: Ministerio de Obras Públicas, Transportes y Medio Ambiente.
- AA.VV. (2009). *Agustín de Betancourt y Molina (1754-1824)*. Barcelona: Escuela Técnica Superior de Ingenieros Industriales de Barcelona (Universidad Politécnica de Cataluña).
- Betancourt, & Molina, A. (1807). *Proposition pour établir une nouvelle machine pour creuser le canal et le Port de Venise*. Retrieved August 16, 2017, from http://fundacionorotava.es/pynakes/betan_propo_fr_01_1807-LiSe
- Betancourt, & Molina, A. (1808). *Explication d'une machine destinée à curer les ports de mer*. Retrieved August 16, 2017, from http://fundacionorotava.es/pynakes/lise/betan_expli_fr_01_1808
- Bogoliúbov, A. N. (1973). *Agustín de Betancourt: un héroe español del progreso*. Madrid: Seminarios y Ediciones.
- London Charter (2009). Retrieved August 16, 2017, from <http://www.londoncharter.org>
- Carta de Sevilla (2012). Retrieved August 16, 2017, from <http://www.arqueologiavirtual.com/carta/wp-content/uploads/2012/03/BORRADOR-FINAL-FINAL-DRAFT.pdf>
- Cioranescu, A. (1965). *Agustín de Betancourt: su obra técnica y científica*. La Laguna de Tenerife: Instituto de Estudios Canarios.
- Gutiérrez Baños, F., Morillo Rodríguez, F. M., San José Alonso, J. I., & Fernández Martín, J. J. (2016). 3D virtual reconstruction of the choir of the convent of Santa Clara in Toro (Zamora): recovering a medieval space of female devotion through photogrammetric recording and rendering techniques. *Virtual Archaeology Review*, 7(15), 123–134. doi:10.4995/var.2016.5983
- Martín Medina, A. (2006). *Agustín de Betancourt y Molina*. Madrid: Dykinson.
- Muñoz Bravo, J. (2008). *Biografía cronológica de Don Agustín de Betancourt y Molina en el 250 aniversario de su nacimiento*. Murcia: Acciona Infraestructuras.
- Padron Acosta, S. (1958). *El ingeniero Agustín de Béthencourt y Molina*. La Laguna de Tenerife: Instituto de Estudios Canarios.
- Portalés, C., Alonso-Monasterio, P., & Viñals, M.J. (2017). 3D virtual reconstruction and visualisation of the archaeological site castellet de Bernabe (Lliria, Spain). *Virtual Archaeology Review*, 8(16), 75–82. doi:10.4995/var.2017.5890
- Proyecto Digital Betancourt (2017). Retrieved August 16, 2017, from <http://fundacionorotava.es/betancourt>
- Rojas-Sola, J. I., Porras-Galán, J., & García-Ruesgas, L. (2016). Digital 3D reconstruction of Agustín de Betancourt's historical heritage: The machine for cutting grass in waterways. *Virtual Archaeology Review*, 7(14), 20–30. doi:10.4995/var.2016.5291
- Rojas-Sola, J. I., & De la Morena-de la Fuente, E. (2017a). Agustín de Betancourt's plunger lock: Approach to its geometric modeling with Autodesk Inventor Professional. In *International Joint Conference on Mechanics, Design Engineering and Advanced Manufacturing (JCM)* (pp. 757–765). Catania, Italy. doi:10.1007/978-3-319-45781-9_76
- Rojas-Sola, J. I., & De la Morena-de la Fuente, E. (2017b). Agustín de Betancourt's wind machine for draining marshy ground: Approach to its geometric modeling with Autodesk Inventor Professional. *Technologies*, 5(1), article 2. doi: 10.3390/technologies5010002
- Rumeu de Armas, A. (1990). *El Real Gabinete de Máquinas del Buen Retiro: origen, fundación y vicisitudes: una empresa técnica de Agustín de Betancourt*. Madrid: Castalia - Fundación Juanelo Turriano.
- Villar-Ribera, R., Hernandez-Abad, F., Rojas-Sola, J. I., & Hernandez-Diaz, D. (2011). Agustín de Betancourt's telegraph: Study and virtual reconstruction. *Mechanism and Machine Theory*, 46(6), 820–830. doi:10.1016/j.mechmachtheory.2011.01.008
- Shih, R.A. (2015). *Parametric Modeling with Autodesk Inventor 2016*. Mission (Kansas, USA): SDC Publications.